

Rapid Link

RASP

Generation Change of RA-SP to RASP 4.0

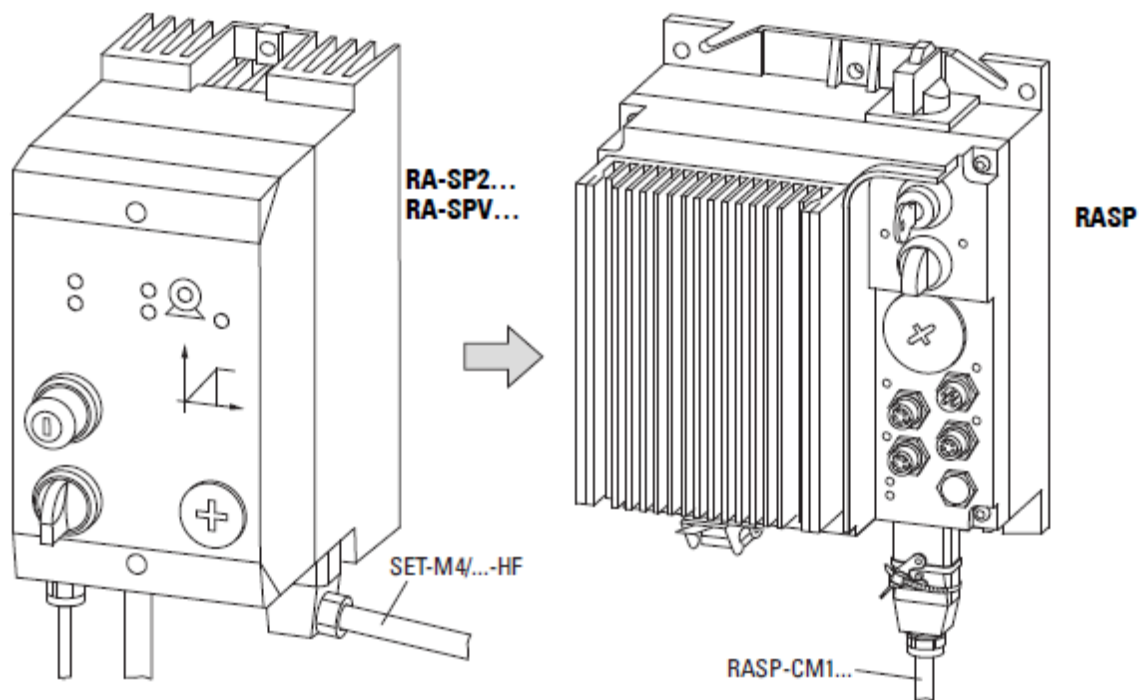

Level 3	<ul style="list-style-type: none"> <li>1 – Fundamental – No previous experience necessary</li> <li>2 – Basic – Basic knowledge recommended</li> <li>3 – Advanced – Reasonable knowledge required</li> <li>4 – Expert – Good experience recommended</li> </ul>
---------	---

All proprietary names and product designations are brand names or trademarks registered to the relevant title holders.

### **Break-Down Service**

Please call your local representative:

[Eaton.eu/aftersales](https://Eaton.eu/aftersales)

[Eaton.com/us/en-us/support.html](https://Eaton.com/us/en-us/support.html)

Original Application Note is the English version of this document.

All non-English language versions of this document are translations of the original application note.

1. Edition 2020, publication date 08/2020

Copyright

© 2020 by Eaton Industries GmbH, 53115 Bonn

All rights reserved, also for the translation.

No part of this application note may be reproduced, stored in a retrieval system, or transmitted in any form or by any means, electronic, mechanical, photocopying, micro-filming, recording or otherwise, without the prior written permission of Eaton Industries GmbH, Bonn.

Subject to alteration.

# Content

- 1 General .....6
- 2 Dimensions .....6
- 3 AS-I Profile .....7
- 4 Replacement Sequence.....7
- 5 Communication cable between PC and RASP.....8
- 6 Optional keypad RASP-KEY-S1.....9
- 7 RASP Motor cable (RASP-CM1-...).....9
- 8 References..... 10

# Danger! - Dangerous electrical voltage!

- Disconnect the power supply of the device.
- Ensure that devices cannot be accidentally restarted.
- Verify isolation from the supply.
- Cover or enclose any adjacent live components.
- Follow the engineering instructions (AWA/IL) for the device concerned.
- Only suitably qualified personnel in accordance with EN 50110-1/-2 (VDE 0105 Part 100) may work on this device/system.
- Before installation and before touching the device ensure that you are free of electrostatic charge.
- The functional earth (FE, PES) must be connected to the protective earth (PE) or the potential equalization. The system installer is responsible for implementing this connection.
- Connecting cables and signal lines should be installed so that inductive or capacitive interference does not impair the automatic control functions.
- Suitable safety hardware and software measures should be implemented for the I/O interface so that an open circuit on the signal side does not result in undefined states.
- Deviations of the mains voltage from the rated value must not exceed the tolerance limits given in the specification, otherwise this may cause malfunction and/or dangerous operation.
- Emergency stop devices complying with IEC/EN 60204-1 must be effective in all operating modes. Unlatching of the emergency-stop devices must not cause a restart.
- Devices that are designed for mounting in housings or control cabinets must only be operated and controlled after they have been properly installed and with the housing closed.
- Wherever faults may cause injury or material damage, external measures must be implemented to ensure a safe operating state in the event of a fault or malfunction (e.g. by means of separate limit switches, mechanical interlocks etc.).
- Frequency inverters may have hot surfaces during and immediately after operation.
- Removal of the required covers, improper installation or incorrect operation of motor or frequency inverter may destroy the device and may lead to serious injury or damage.
- The applicable national safety regulations and accident prevention recommendations must be applied to all work carried on live frequency inverters.
- The electrical installation must be carried out in accordance with the relevant electrical regulations (e. g. with regard to cable cross sections, fuses, PE).
- Transport, installation, commissioning and maintenance work must be carried out only by qualified personnel (IEC 60364, HD 384 and national occupational safety regulations).
- Installations containing frequency inverters must be provided with additional monitoring and protective devices in accordance with the applicable safety regulations. Modifications to the frequency inverters using the operating software are permitted.
- All covers and doors must be kept closed during operation.
- To reduce the hazards for people or equipment, the user must include in the machine design measures that restrict the consequences of a malfunction or failure of the frequency inverter (increased motor speed or sudden standstill of motor). These measures include: – Other independent devices for monitoring safety related variables (speed, travel, end positions etc.).
  - Electrical or non-electrical system-wide measures (electrical or mechanical interlocks).
  - Never touch live parts or cable connections of the frequency inverter after it has been disconnected from the power supply. Due to the charge in the capacitors, these parts may still be alive after disconnection. Consider appropriate warning signs.

# Disclaimer

The information, recommendations, descriptions, and safety notations in this document are based on Eaton's experience and judgment and may not cover all contingencies. If further information is required, an Eaton sales office should be consulted. Sale of the product shown in this literature is subject to the terms and conditions outlined in the applicable Terms and Conditions for Sale of Eaton or other contractual agreement between Eaton and the purchaser. THERE ARE NO UNDERSTANDINGS, AGREEMENTS, WARRANTIES, EXPRESSED OR IMPLIED, INCLUDING WARRANTIES OF FITNESS FOR A PARTICULAR PURPOSE OR MERCHANTABILITY, OTHER THAN THOSE SPECIFICALLY SET OUT IN ANY EXISTING CONTRACT BETWEEN THE PARTIES. ANY SUCH CONTRACT STATES THE ENTIRE OBLIGATION OF EATON. THE CONTENTS OF THIS DOCUMENT SHALL NOT BECOME PART OF OR MODIFY ANY CONTRACT BETWEEN THE PARTIES. As far as applicable mandatory law allows so, in no event will Eaton be responsible to the purchaser or user in contract, in tort (including negligence), strict liability, or otherwise for any special, indirect, incidental, or consequential damage or loss whatsoever, including but not limited to damage or loss of use of equipment, plant or power system, cost of capital, loss of power, additional expenses in the use of existing power facilities, or claims against the purchaser or user by its customers resulting from the use of the information, recommendations, and descriptions contained herein. The information contained in this manual is subject to change without notice.

# 1 General

The following information indicates the differences that must be taken into account when expanding systems or creating new projects with RASP (Rapid Link 4.0) units, as well as when using them to replace RA-SP2... and/or RA-SPV... devices.

The devices have the following major differences:

- Dimensions
- AS-Interface profile
- Parameter software and technical overview
- Type and design of motor cables.

The controls' handling and functions remain the same. RASP combines the functionality of RA-SP2... and RA-SPV... in a single device. If required, the vector functionality can be activated via the parameters.

# 2 Dimensions

Figure below shows the dimension of new RASP devices:

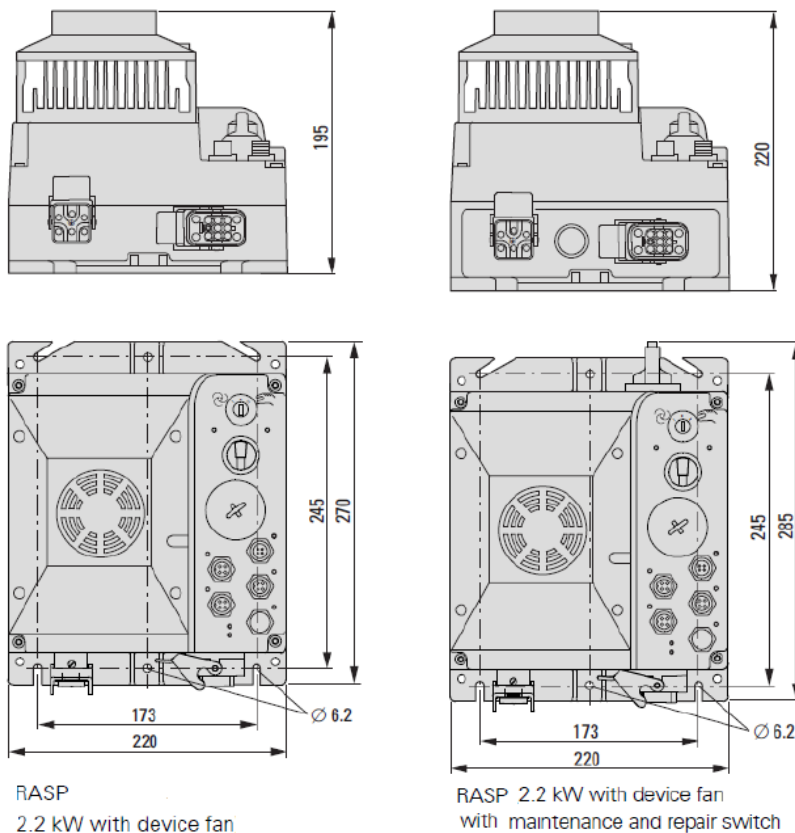

## RASP speed controllers

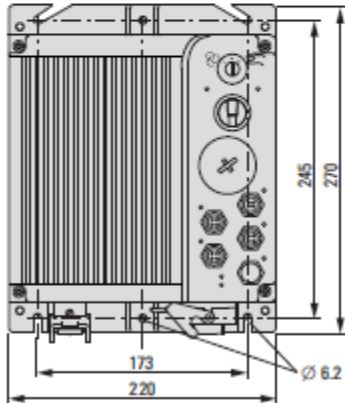
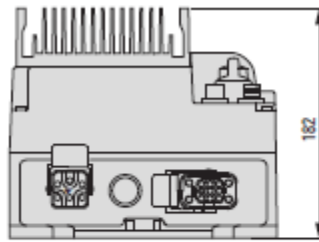
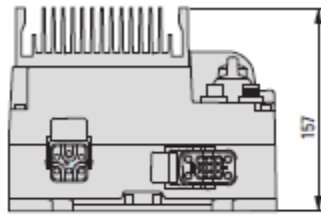

Figure 125: RASP-2, RASP-3, RASP-4

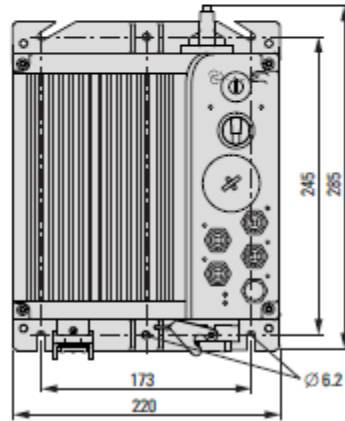

Figure 126: RASP-2, RASP-3, RASP-4 with repair and maintenance switch

## 3 AS-I Profile

RASP... units have AS-i profile S-7.E.0 (old) and AS-i profile S-7.4 (new). Due to the expanded AS-i profile, the master (gateway) needs to carry out a new initialization process if new RASP devices with profile S-7.4 are used as a replacement. To do this, the AS-i master needs to be switched to configuration mode. In this mode, the AS-i master will recognize the type and profile of the AS-i slaves connected to the AS-i cable. The profile is hardcoded into the slave modules during production and cannot be changed. On e.g. PROFIBUS/AS-i gateways, this configuration mode can usually only be activated if there are no ongoing communications with the PROFIBUS. The assignment of Rapid Link inputs/outputs and the data bits remain the same. The PLC programs do not have to be modified.

## 4 Replacement Sequence

Proceed following steps for a proper replacement.

1. Read the parameter from RA-SP... (with DrivesSoft).
2. Read the address from RA-SP... (with Addressing device).
3. Note the DIP-Positions of the RA-SP...
4. Disconnect Motor-, Energy-, Asi-, Sensor-, Actor connectors from RA-SP...
5. Switch Key to HAND Mode (RASP...)
6. Set Parameters of the RASP accordingly (with RASP-KEY-S1 or MaxConnect)

7. Give the address of RA-SP to the RASP...
8. Set the DIP switches of RASP... accordingly.
9. Connect all cables, Line 400 V AC, AS-Interface, Motor and Sensors und Actor.
10. Ready to start.

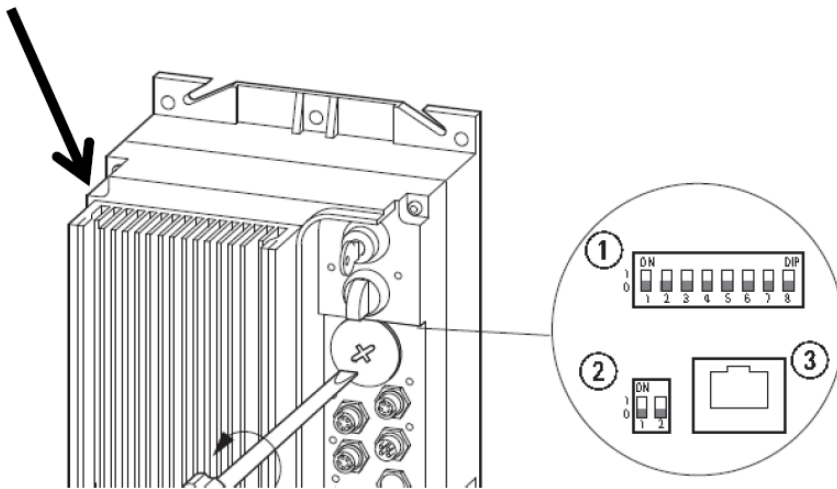

	<p><b>Notice!</b> Before power on it must be ensured that the motor and the motor cable is properly connected.</p>
--	--

## 5 Communication cable between PC and RASP

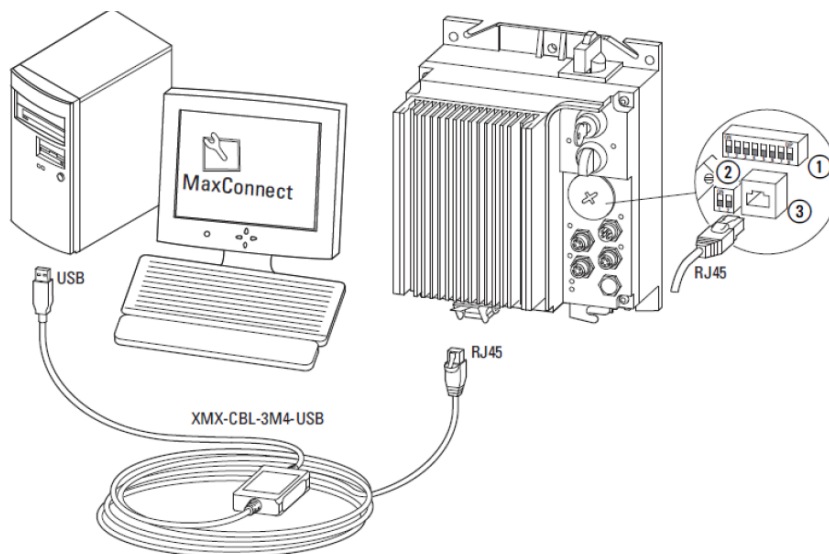

### RASP plug for cable screw gland

- ① Functions, dip switch
- ② dip switch (currently without function)
- ③ Serial interface (RJ 45)

Connection cable XMX-CBL-3M4-USB allows communication and data exchange between RASP and a PC. The cable has a length of about 3.4 m, an interface converter with electrical isolation, an RJ45 plug and a USB port. Connection cable XMX-CBL-3M4-USB is not supplied with the RASP.

## 6 Optional keypad RASP-KEY-S1

The optional RASP-KEY-S1 keypad enables you to configure the RASP’s parameters and view operational data. The Start and Stop keys and the setpoint input have no function. The connection to the RASP requires a patch cable with an RJ45 plug. The optional RASP-KEY-S1 LCD keypad is not included with RASP units. The equipment supplied with the RASP-KEY-S1 LCD keypad includes a 1-m long patch cable.

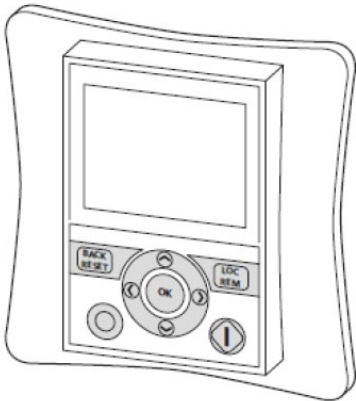

RASP-KEY-S1  
(article no.: 156644)

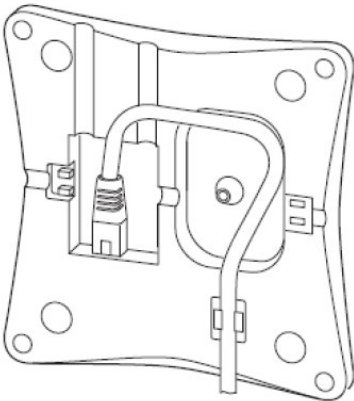

RJ45 socket at the back of LCD keypad RASP-KEY-S1

## 7 RASP Motor cable (RASP-CM1-...)

The motor has to be connected using unshielded, DESINA-compliant, motor cable

RASP-CM1-.. (4 x 1,5mm<sup>2</sup> + 2 x (2 x 0.75) mm<sup>2</sup>) with the following PIN assignment:0

1	1	U1		
Coding	-			
3	3	W1		
4	5			B1
5	7		T1	
6	6			B2
7	2	V1		
8	8		T2	
PE	PE*	PE		

\*PE = green-yellow

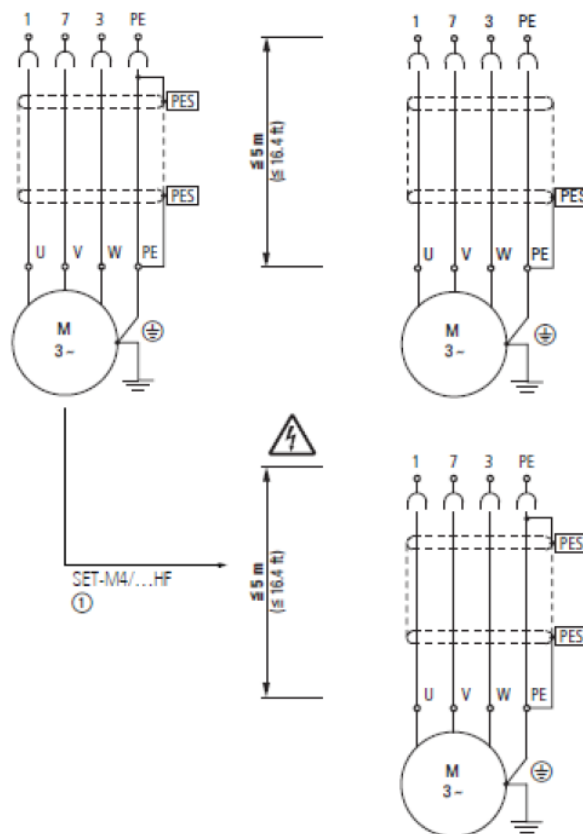
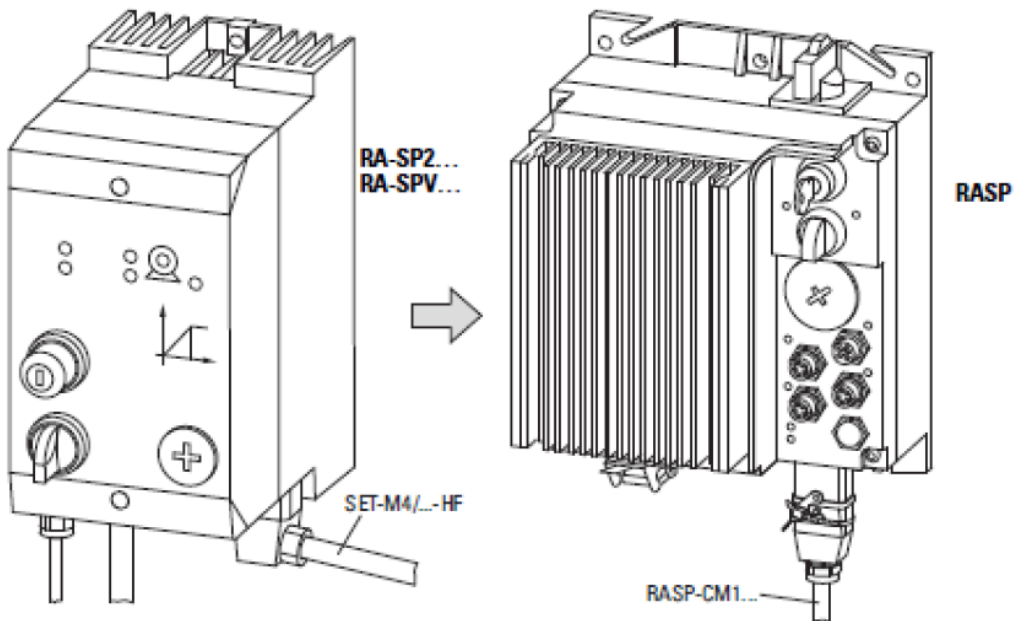

## 8 References

Documentation	RASP4.0	RA-SP	LINK
Manual RASP...	MN03406003Z-EN	AWA2190-1936	<a href="#">DownloadCenter</a>
Instruction Leaflet RASP 4.0	IL0306020Z	AWB2190-1430E	<a href="#">DownloadCenter</a>

Eaton is dedicated to ensuring that reliable, efficient and safe power supply is available when it is needed most. With vast of energy management across different industries, experts at Eaton deliver customized, integrated solutions to solve our customer' most critical challenges.

Our focus is on delivering the right solution for the Application. But decision makers demand more than just Innovative products. They turn to Eaton for an unwavering Commitment to personal support that makes customer Success a top priority. For more information, visit [Eaton.com](https://www.eaton.com)

**Eaton addresses worldwide:**

<https://www.eaton.com/us/en-us/locate/global-locations.html>