

Data Sheet | Item Number: 891-8982/206-601

pre-assembled connecting cable; Eca; Plug/open-ended; 2-pole; Cod. I; H05VV-F 2 x 1.5 mm²; 6 m; 1,50 mm²; blue

<https://www.wago.com/891-8982/206-601>

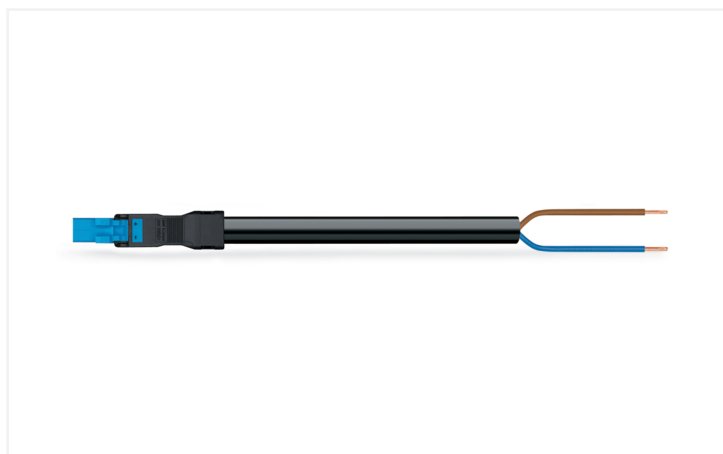

Color: ■ blue

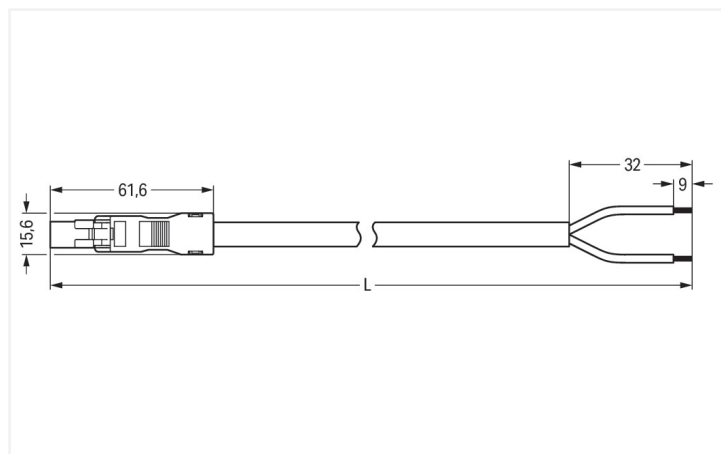

Dimensions in mm

Cable assembly *WINSTA*® MINI with protection type IP20

The *WINSTA*® MINI cable assembly 2-pole supports rapid, correct installation. Whether on PCBs, in control cabinets or for connecting lights – pluggable installation connectors from WAGO allow you to establish connections according to many different requirements in seconds. The color coding and mechanical coding of the pluggable installation connector ensure error-free installation of the individual components – including protection against mismatching. I coding in blue is used to label *WINSTA*® MINI pluggable installation connectors, which are used above all in building automation for controlling lighting. Particularly if only limited space is available, our smallest pluggable connection system, *WINSTA*® MINI, conveniently displays its advantageous properties. It saves space, and, with Push-in CAGE CLAMP® spring pressure connection technology, it also saves time, since the installation is low-maintenance and can be performed without screw connections. According to the European CPR, the fire class of the cables used in construction is essential for the safety of buildings as well. For buildings with average safety requirements, cable assemblies with fire class E are suitable.

Pluggable connections instead of screw connections – cable assemblies from WAGO

A plug and a free end are provided. *WINSTA*® is the pluggable connection system that is perfectly tailored to the strict requirements of electrical installation. It allows fast, secure and, above all, error-free installation of components and cables. Now you can also cut installation expenses without compromising safety and quality: with fire class E eliminates the need for servicing and prevents unnecessary downtime.

- protection against mismatching eliminates errors
- easy tool-free operation, a wide range of coding options
- with I coding for use in building automation (lighting control)
- exact dimensions
- quick replacement of defective units during ongoing operation

Notes

Note Cables with a different fire class can be found in the eShop.

Electrical data

Ratings per	IEC/EN 60664-1		
Overvoltage category	III	III	II
Pollution degree	3	2	2
Nominal voltage	250 V	-	-
Rated impulse withstand voltage	4 kV	-	-
Rated current	16 A	-	-

General information

Note on contact resistance approx. 1 mΩ of contact resistance
approx. 0.25 mΩ contact transition plug/
socket

Connection Data

Total number of potentials	2	Connection 1	
Conductor preparation	ultrasonically tip-bonded	Strip length	9 mm / 0.35 inches
		Pole number	2
		Wire cross-section	1.5 mm ²
		Strip length (outer insulation)	32 mm
		Connection type	Plug - free end

Physical data

Pin spacing	4.4 mm / 0.173 inches
Width	15.6 mm / 0.614 inches
Height	13.2 mm / 0.52 inches
Total length	6 m

Mechanical data

Use	DALI, Lighting Management
Coding	I
Variable coding	No
Marking	+ -
Potential marking	+ -
Mating force of a plug-in connection	approx. 20 ... 70 N (depending on pole number)
Retention force of a plug-in connection	when locked: > 80N
Unmating force of a plug-in connection	when unlocked: approx. 20 ... 70 N (depending on pole number)
Number of mating cycles	200, without resistive load
Connection type	Plug - free end
Type of pre-assembled cable	Connecting cable
Cable type	H05VV-F 2x1.5
Protection type	IP20; IP40 when mated

Plug-in connection

Mismating protection	Yes
Note on mismating protection	All <i>WINSTA</i> ® components are 100% protected against mismating when: a.) plugging different numbers of poles b.) plugging while rotated 180 c.) plugging while laterally staggered d.) plugging one pole
Locking lever	Can be retrofitted
Locking of plug-in connection	Locking lever
Note on locking system	All connectors for mounted installations (snap-in versions for lighting fixtures or devices, all types of PCB and distribution connectors) are factory-equipped with locking levers to ensure plugs and sockets are securely locked. Additional locking levers are only required for flying leads (plug/socket).

Material data

Note (material data)	Information on material specifications can be found here
Color	blue
Insulation material (main housing)	Polyamide (PA66)
Fire class per EN 50575	E _{ca}
Contact material	Copper or copper alloy; surface-treated
Contact Plating	Tin
Fire load	179.585 MJ
Connector color	blue
Strain relief color	black
Sheathed cable color	black

Material data

Printing color of sheathed cable	white
Halogen-free	No
Silicon-free	Yes
Sheath material	PVC
Rubber cable	No
Weight	497.4 g
Copper weight of the raw cable	0.029 kg/m

Environmental requirements

Processing temperature	-5 ... +40 °C
Continuous operating temperature	-35 ... +85 °C
Note on continuous operating temperature	Cable for temperatures ≤ 70 °C (including halogen-free) Insulating parts for temperatures ≤ 105 °C

Commercial data

PU (SPU)	1 pcs
Packaging type	unpacked
Country of origin	PL
GTIN	4055143350969
Customs tariff number	85444290900

Product Classification

UNSPSC	26121629
eCl@ss 10.0	27-44-06-04
eCl@ss 9.0	27-44-06-04
ETIM 9.0	EC002587
ETIM 10.0	EC002587
ECCN	NO US CLASSIFICATION

Environmental Product Compliance

RoHS Compliance Status	Compliant, No Exemption
------------------------	-------------------------

Approvals / Certificates

General approvals



Approval	Standard	Certificate Name
CCA DEKRA Certification B.V.	EN 61535	NTR NL-7971
KEMA/KEUR DEKRA Certification B.V.	EN 61535	71-123232

Declarations of conformity and manufacturer's declarations

Approval	Standard	Certificate Name
EU-Declaration of Confor- mity WAGO GmbH & Co. KG	-	-
UK-Declaration of Confor- mity WAGO GmbH & Co. KG	-	-

Downloads

Environmental Product Compliance

Compliance Search

Environmental Product Compliance
891-8982/206-601



Documentation

Bid Text

891-8982/206-601	19.02.2019	xml 3.05 KB	
891-8982/206-601	24.11.2014	doc 24.50 KB	

CAD/CAE-Data

CAE data

WSCAD Universe
891-8982/206-601



1 Compatible Products

1.1 Required Accessories

1.1.1 Locking system

1.1.1.1 Locking system



Item No.: 890-111

Locking lever; for flying leads; for tool operation; black

Item No.: 890-131

Locking lever; for flying leads; for tool operation; white

Item No.: 890-101

Locking lever; for manual operation; black

Item No.: 890-121

Locking lever; for manual operation; white

1.2 Optional Accessories

1.2.1 Cover

1.2.1.1 Cover



Item No.: 897-2001

Protective cap; Type1; for sockets and plugs; PVC; red

1.2.2 Installation

1.2.2.1 Mounting accessories



Item No.: 890-310

Mounting carrier; 2- to 5-pole; for flying leads; black



Item No.: 890-311

Mounting carrier; 2- to 5-pole; for flying leads; white