

Data Sheet | Item Number: 221-519/002-006

Mounting carrier; for 10-wire connectors; 221 Series - 4 mm²; for side screw mounting; blue

<https://www.wago.com/221-519/002-006>

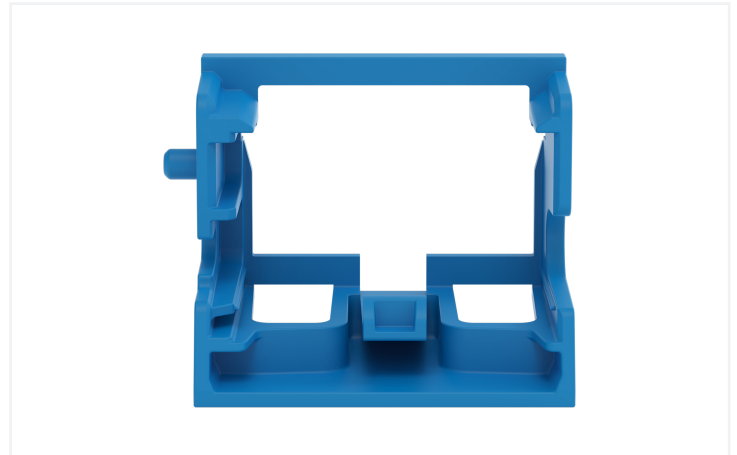
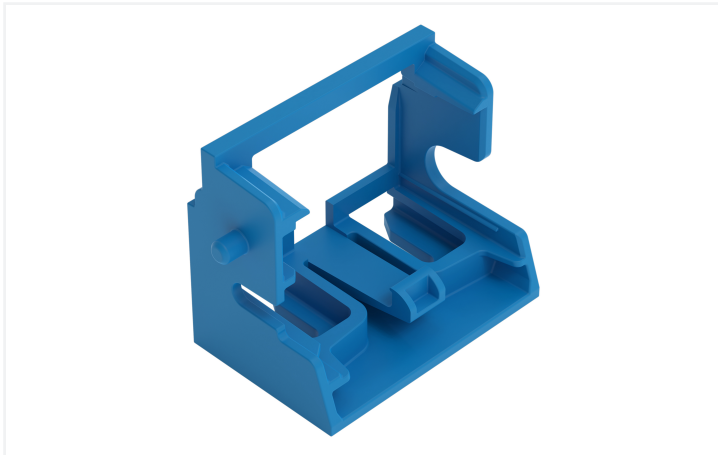

Color: ■ blue

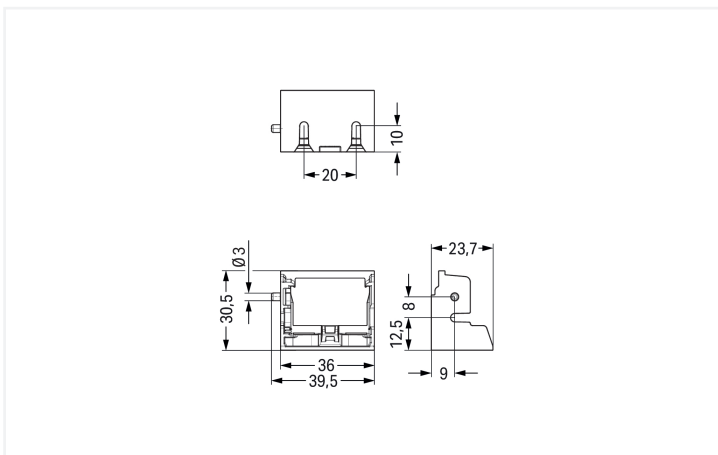
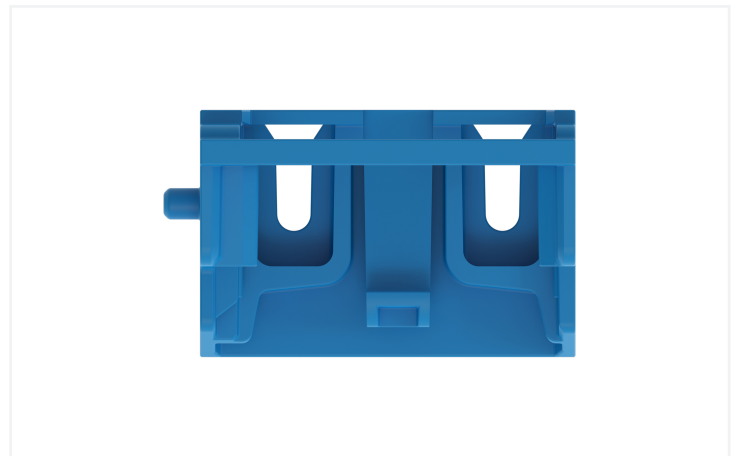
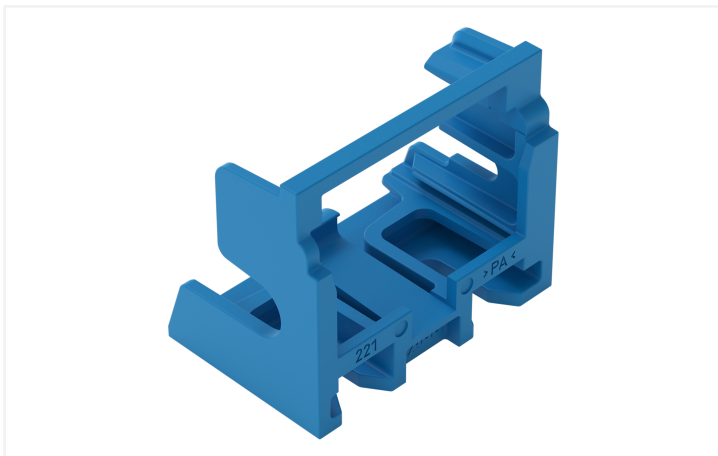

Physical data

Width	39.5 mm / 1.555 inches
Height	30.5 mm / 1.201 inches
Depth	23.7 mm / 0.933 inches

Mechanical data

Mounting type	Screw mount
Suitable	for 10-wire connectors (4 mm ²)

Material data

Note (material data)	Information on material specifications can be found here
Color	blue
Material group	I
Insulation material (main housing)	Polyamide (PA66)
Flammability class per UL94	V0
Fire load	0.145 MJ
Weight	4.8 g

Commercial data

PU (SPU)	10 pcs
Packaging type	Box
Country of origin	CN
GTIN	4066966603309
Customs tariff number	39269097900

Product Classification

UNSPSC	39121421
ETIM 9.0	EC002848
ETIM 10.0	EC002848
ECCN	NO US CLASSIFICATION

Environmental Product Compliance

RoHS Compliance Status	Compliant, No Exemption
------------------------	-------------------------

Downloads

Environmental Product Compliance

Compliance Search

Environmental Product
Compliance
221-519/002-006



CAD/CAE-Data

CAD data

2D/3D Models
221-519/002-006



1 Compatible Products

1.1 Optional Accessories

1.1.1 Marking

1.1.1.1 Marking strip



Item No.: 210-833

Marking strips; 25 m on roll; 6 mm wide;
plain; Self-adhesive; white