

1SDH000909R0001 B2410

Emax VF

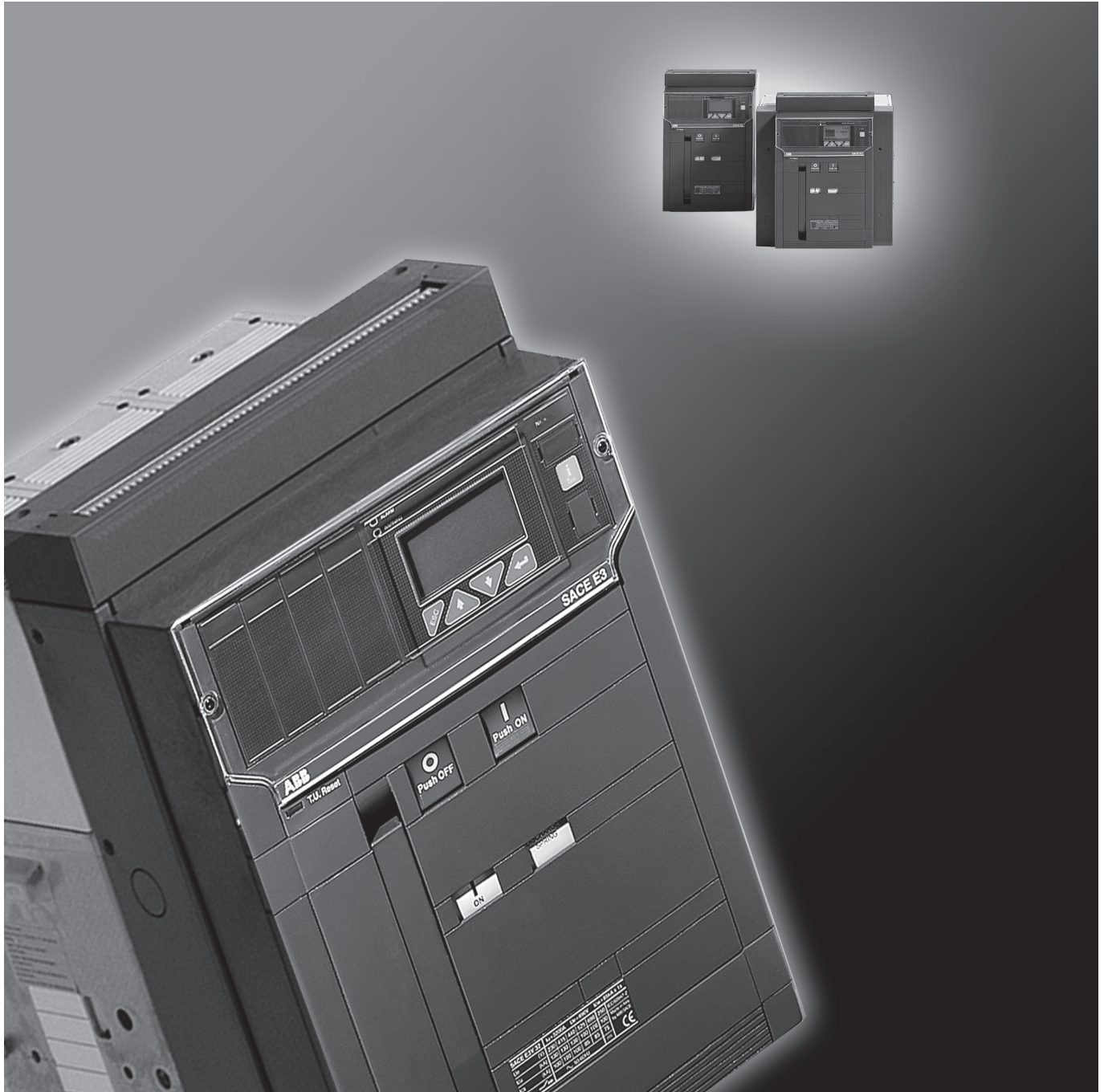

Dwg.		Resp. Off.		Title Installation, service and maintenance instructions for low voltage air circuit-breakers	Language
App.		Take over Off.			EN
Model	L5272	L6567	B2410	Apparatus Emax	Scale
	L5712	B2204			
ABB		ABB SACE		Doc. no.	1SDH000909R0001

Index

1.	Description	5	8.4.10.	Maintenance operations; final checks:	26
1.1.	General characteristics	5	8.4.11.	Interlock	26
1.2.	External front view of the circuit-breaker	5	8.4.12.	Withdrawable	26
1.3.	Rating plate	5	9.	Measures to be taken for any operating anomalies.	27
1.3.1.	Circuit-breaker rating plate	5	10.	Accessories	28
1.4.	Moving part construction characteristics	6	10.1.	Electrical accessories	28
1.5.	Fixed part construction characteristics	6	10.2.	Mechanical locks	30
2.	Checking on receipt	7	10.3.	Notes for Emax LTT Low Temperature accessories.	31
3.	Storage, lifting and weights	7	10.4.	Spare parts and retrofitting	31
4.	Installation	8	11.	Protection releases - General notes.	32
4.1.	Installation room.	8	11.1.	Notes for dielectric stiffness tests.	32
4.2.	Installation of the fixed circuit-breaker	8	11.2.	Abbreviations and notes	33
4.3.	Installation of the fixed part of the withdrawable circuit-breaker	8	11.2.1.	Abbreviations	33
4.3.1.	Preparation of the fixed part	8	11.2.2.	Notes	33
4.3.2.	Installation of the fixed part (Fig. 12)	9	12.	SACE PR122/VF Release - Identification	34
4.4.	Installation of the flange on the compartment door (Fig. 13)	9	12.1.	General	34
5.	Electrical connections.	10	12.1.1.	Main Features	34
5.1.	Connections to the power circuit	10	12.1.2.	Standard Reference	34
5.1.1.	Shapes of the terminals	10	12.1.3.	Operation condition	34
5.1.2.	Examples of positioning the connection busbars according to the types of terminals	10	12.1.3.1.	Environmental condition.	34
5.1.3.	Assembly procedure for the connection busbars.	11	12.1.3.2.	Power Supply specifications	35
5.2.	Earthing	11	12.2.	User Interface	35
5.3.	Wiring the circuit-breaker auxiliary circuits	11	12.2.1.	LEDs.	35
5.3.1.	Interfacing elements for fixed circuit-breakers	11	12.2.2.	Display.	36
5.3.2.	Withdrawable circuit-breaker	12	12.2.2.1.	Ammeters on Display	36
5.4.	Conversion of the auxiliary contacts or of the signalling contacts (disconnected - test isolated - connected), from normally closed (opening) to normally open (closing) or vice versa	12	12.2.2.2.	CB and Trip Unit Error	36
6.	Putting into service	14	12.2.2.3.	Working ICON	37
6.1.	General procedures	14	12.2.3.	Push Button	37
7.	Instructions for use	15	12.2.4.	Rating plug	37
7.1.	Operating and signalling parts	15	12.2.5.	Optional Module.	37
7.2.	Circuit-breaker closing and opening procedures	16	12.2.6.	External Module.	37
7.3.	Racking-in/out operation	17	12.3.	User Menu.	37
8.	Maintenance.	19	12.3.1.	Main Area	38
8.1.	Warning	19	12.3.2.	Menu Area	38
8.2.	Maintenance programme	19	12.3.2.1.	Changing of parameters.	38
8.2.1.	Circuit-breaker life.	19	12.3.3.	Protections	38
8.2.2.	Maintenance program.	19	12.3.3.1.	L Protection	39
8.3.	First level maintenance operations	19	12.3.3.2.	I Protection	39
8.3.1.	Preliminary operations:	19	12.3.3.3.	T Protection	39
8.3.2.	Checks and general cleaning:	19	12.3.3.4.	Load Protection	40
8.3.3.	Circuit-breaker connections and connections between the circuit-breaker and the control panel	20	12.3.3.5.	Trip performances and activation time	40
8.3.4.	Dismantling tab and cap	20	12.3.3.6.	Curves.	41
8.3.5.	Mechanical control	21	12.3.4.	Measurements.	41
8.3.6.	Electrical and mechanical accessories	21	12.3.4.1.	Trip.	41
8.3.7.	Protection releases	21	12.3.4.2.	Events	41
8.3.8.	Test with Ekip Connect (optional)	21	12.3.4.3.	Measurements.	42
8.3.9.	Maintenance operations; final checks.	22	12.3.4.4.	Contact Wear	42
8.3.10.	Interlock	22	12.3.5.	Settings	42
8.4.	Second level maintenance operations	22	12.3.5.1.	Circuit Breaker.	42
8.4.1.	Preliminary operations:	22	12.3.5.2.	HW trip	42
8.4.2.	General checks and cleaning:	22	12.3.5.3.	Modules	43
8.4.3.	Connections between the circuit-breaker and the control panel.	23	12.3.5.4.	Datalogger.	43
8.4.4.	Dismantling the tab, cap and arcing chambers	23	12.3.5.5.	Measure Store Time.	44
8.4.5.	Mechanical control	24	12.3.5.6.	System	44
8.4.6.	Electrical and mechanical accessories	24	12.3.5.7.	Display contrast	44
8.4.7.	Checking contact wear	25	12.3.6.	Test	44
8.4.8.	Protection releases	25	12.3.6.1.	CB Status	44
8.4.9.	Test with Ekip Connect (optional)	25	12.3.6.2.	Autotest	44
			12.3.6.3.	Trip Test	44
			12.3.6.4.	COM Module	44
			12.3.6.5.	SIGNALLING Module	45
			12.3.7.	About this section	45
			12.4.	Modules	45
			12.4.1.	PR120/D-M	45
			12.4.2.	PR120/K.	45
			12.4.2.1.	Digital Input	45
			12.4.2.2.	Output Contact	46
			12.4.3.	PR030/B.	46
			12.4.4.	BT030-USB	46
			12.4.5.	Ekip T&P.	47

Model	B2342	B2410		Apparatus	Emax VF	Scale
				Doc. No	1SDH000909R0001	Page No 3/66

12.4.6.	Ekip Connect	47
12.5.	Default Settings	48
12.6.	Help	48
12.6.1.	Error Messages	48
12.6.2.	Troubleshooting	49
13.	Overall dimensions	50
14.	Circuit diagrams	57
14.1.	Caption	57
14.2.	Description of figures	58
14.3.	Incompatibilities	58
14.4.	Notes	58

Model	B2342	B2410		Apparatus	Emax VF	Scale
				Doc. no.	1SDH000909R0001	Page No 4/66

1. Description

1.1. General characteristics

The SACE Emax series of circuit-breakers consists of a steel sheet structure which houses the operating mechanism, the poles and the auxiliary parts. Each pole, insulated from the others, contains the circuit-breaking parts and the current sensing resistor of the corresponding phase.

The fixed version circuit-breaker has its own terminals for connection to the power circuit; in the withdrawable version the circuit-breaker comprises the moving part of the apparatus, which is completed with a fixed part fitted with the terminals for connection to the power circuit of the installation. The moving part and the fixed part coupled by means of special contacts installed in the fixed part.

1.2. External front view of the circuit-breaker

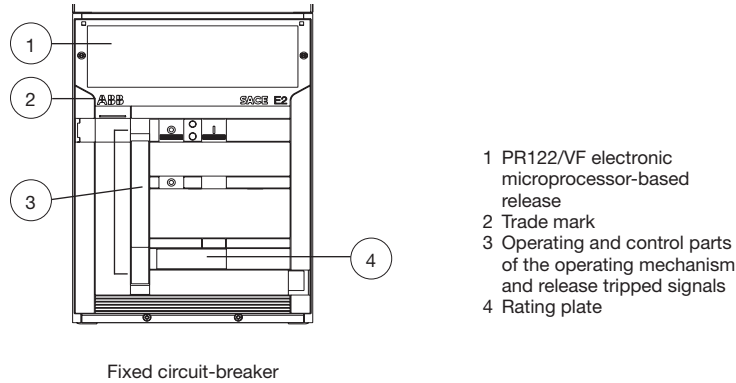

Fig. 1

1.3. Rating plate

1.3.1. Circuit-breaker rating plate

SACE E2N/VF12		_u =1200A U _e =1000V		IEC 60947-2
U _e (V)		690	1000	I _{cw} (1s)=10kA
I _{cu} (kA)		15	10	U _{imp} =8kV
I _{cs} (kA)		15	10	ABB SACE Italy
cat.A		~ 50-60Hz		

Fig. 2

The SACE Emax VF circuit breakers can be used in applications with variable frequency from 1Hz to 60Hz, with rated voltage up to 1000V. The rated impulse withstand voltage of the circuit breakers is 8kV.

The SACE Emax VF switch disconnectors up to 2500A are available also in LTT version; this special version, designed for low temperature environment, permits to extend the operating temperature range from -40°C to +70°C.

Model	B2342	B2410		Apparatus	Emax VF	Scale
				Doc. No	1SDH000909R0001	Page No 5/66

1.4. Moving part construction characteristics

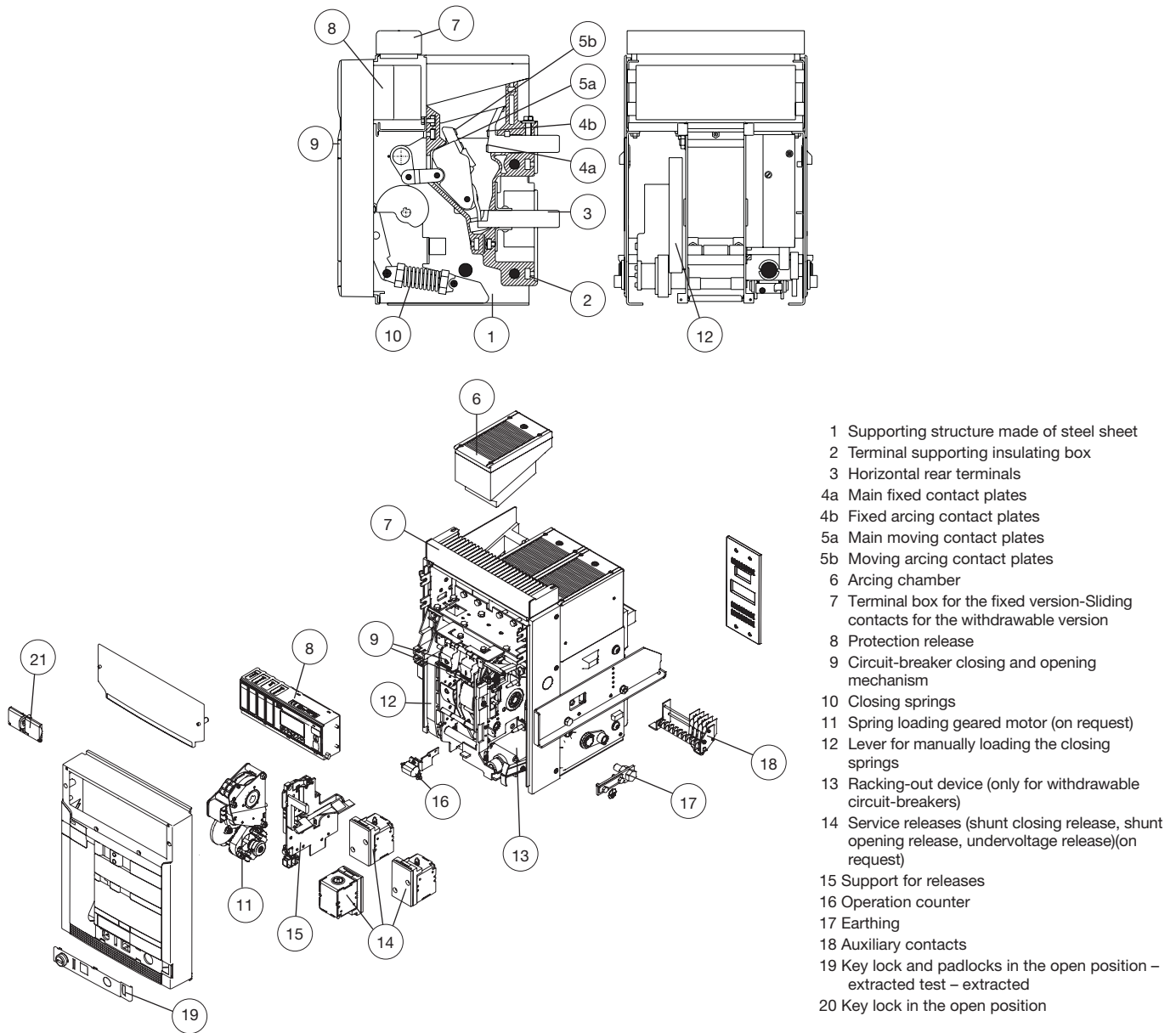

Fig. 3

1.5. Fixed part construction characteristics

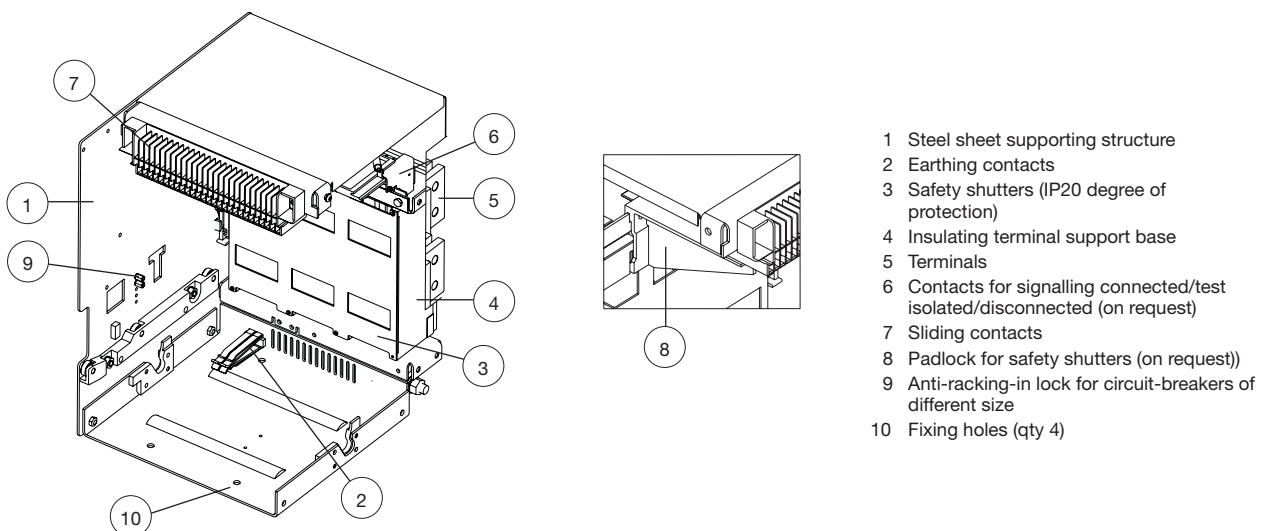

Fig. 4

Model	B2342	B2410		Apparatus	Emax VF	Scale
				Doc. no.	1SDH000909R0001	Page No 6/66

2. Checking on receipt

Examine the state of the material received and its consistency with the content of the order. Should any damage or errors be found on unpacking, which must be carried out carefully, make the relative notification within and not over 5 days from the receipt of the material. The notification must indicate the number of the shipping note.

3. Storage, lifting and weights

The circuit-breaker, protected by an external wooden crate, is fixed by means of screws to the transport pallet or to the bottom of the packing case.

If the circuit-breaker has to remain in the warehouse even for a short time before being put into service, after checking it on receipt, it must be put back in its container and covered with a waterproof sheet.



CAUTION:

- Use a dry, dust-free room free of aggressive chemical agents as a storage room,
- Position the circuit-breaker and any fixed part on a horizontal surface, not in direct contact with the floor, but on a suitable support surface (Fig. 5);
- The maximum number of stackable circuit-breakers is indicated in figure 6.
- Keep the circuit-breaker in the open position and with the closing springs unloaded to avoid unnecessary stresses and the risk of accidents to the person.
- Storage temperature: -40°C ... + 70°C

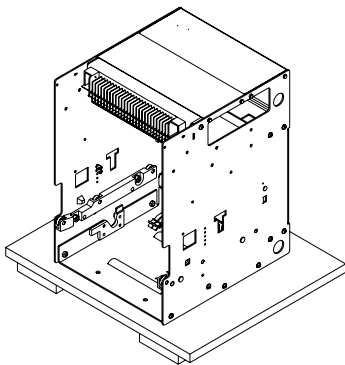

Fig. 5

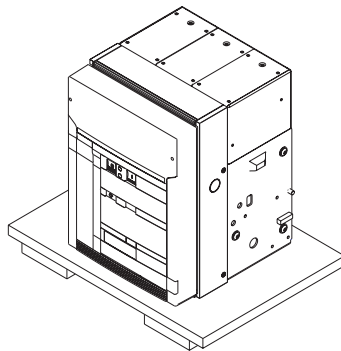
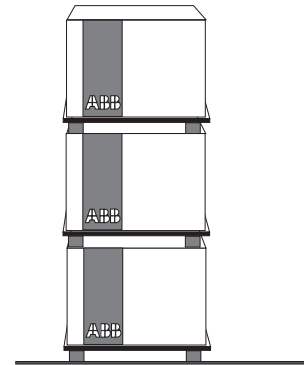

Fig. 6



With regard to lifting, follow the instructions: the circuit-breakers must be placed on a sturdy supporting surface and lifted, preferably, by means of a special fork-lift truck. However, the use of ropes is allowed. In this case, the lifting ropes must be hooked up as shown in the figures (the lifting plates are always supplied with the circuit-breaker).

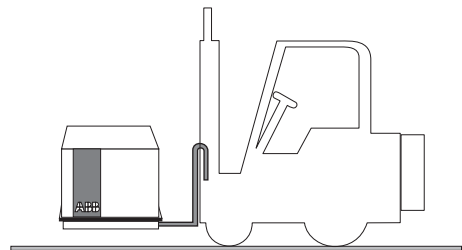
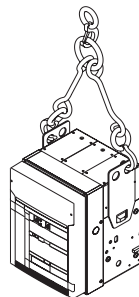
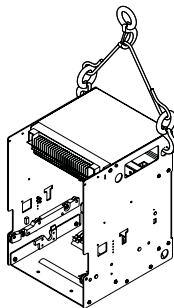

Fig. 7

Table of the circuit-breaker weights (Kg.)

Selective circuit-breaker	Fixed version	Withdrawable version
E2	50	78
E3	66	104

Notes:

- The weights indicated in the table are intended for circuit-breakers complete with PR122/VF release, excluding the accessories.
- The withdrawable version includes the moving part in the same conditions as above, and the fixed part with horizontal rear terminals.

Model	B2342	B2410		Apparatus	Emax VF	Scale
				Doc. No	1SDH000909R0001	Page No 7/66

4. Installation

4.1. Installation room

Install the circuit-breaker in a dry, dust-free, non-corrosive room, and in such a way that it is not subject to shocks or vibrations. Where this is not possible, install it inside a switchboard with a suitable degree of protection.

For the preparation of the installation room, please refer to the "Overall dimensions" paragraph, which gives information on the following points:

- minimum installation volumes of the circuit-breakers and derived versions
- distances to be respected for circuit-breakers in compartments
- overall dimensions of the circuit-breakers
- fixing drillings
- compartment door drillings.

The installation, commissioning and any ordinary and extraordinary maintenance have to be done by skilled personnel, with a detailed knowledge of the apparatus.

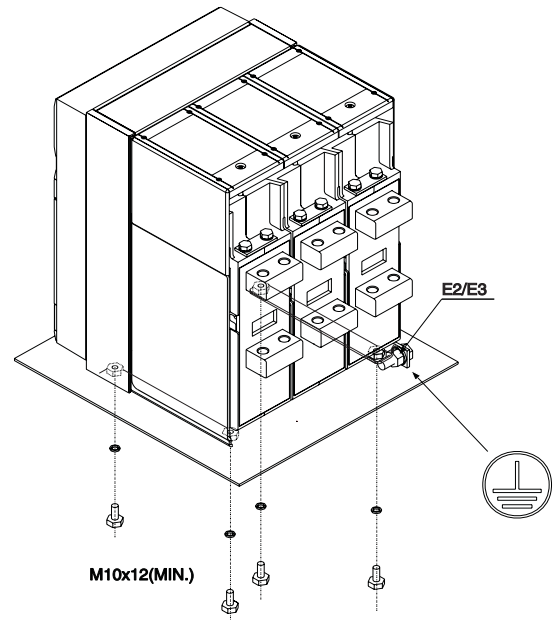

Fig.8



WARNING: The installation, commissioning and any ordinary and extraordinary maintenance of the circuit-breaker and accessories must be performed by skilled personnel, with a detailed knowledge of the equipment.



WARNING ELECTRICAL SHOCK HAZARD:

Disconnect and lock and tag out all electrical power feeds to avoid any potential shock hazard when you are assembling, installing maintaining or removing the circuit breaker from service. Some operations must be performed when the circuit-breaker is energized. In this case, reasonable care and compliance with all safe working practices is required.

4.2. Installation of the fixed circuit-breaker

Fix the circuit-breaker to a horizontal surface using the screws (M10 x 12 min.).

4.3. Installation of the fixed part of the withdrawable circuit-breaker

4.3.1. Preparation of the fixed part

Assembly of the anti-racking-in lock

Before installing the fixed part, it is necessary to check the presence of the anti-racking-in lock for circuit-breakers with different electrical characteristics from those of the fixed part. If the anti-racking-in lock has been supplied separately, proceed to assemble it as follows.

- On the self-adhesive plate (4), find the assembly position of the stop bolts in relation to the circuit-breaker which has to be housed in the fixed part.
- Insert the hexagonal-head screws (1) in the holes found in the previous item as shown in the figure.
- Fix the screws with the washers (2) and the hexagonal stops (3).

Make sure that the anti-racking-in lock corresponding to the one installed on the fixed part is present on the circuit-breaker (moving part).

- Anti-racking-in plate on the moving part (5).

Example for E2N 16 according to the nameplate diagram

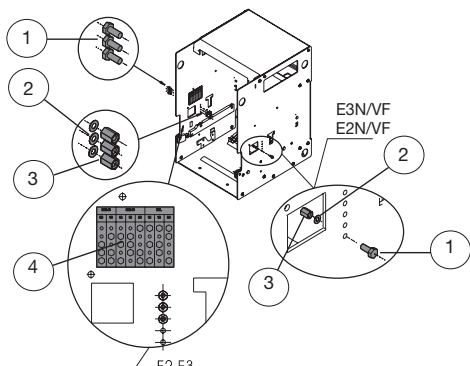

Fig. 9

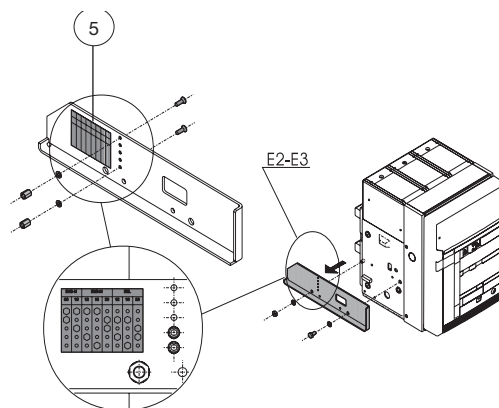

Fig. 10

Model	B2342	B2410		Apparatus	Emax VF	Scale
				Doc. no.	1SDH000909R0001	Page No 8/66

4.3.2. Installation of the fixed part (Fig. 12)

Attach the fixed part by means of the screws (1), washers (2) and nuts (3) (M8 x 16), supplied by ABB SACE. if other screws are used, make sure that the head of the screws does not extend more than 5.5 mm from the base of the fixed part.

4.4. Installation of the flange on the compartment door (Fig. 13)

- Make the compartment door drillings specified in the “Overall dimensions” paragraph.
- Attach the flange (1) on the front of the compartment door, fixing it from the inside by means of the self-tapping screws (2).

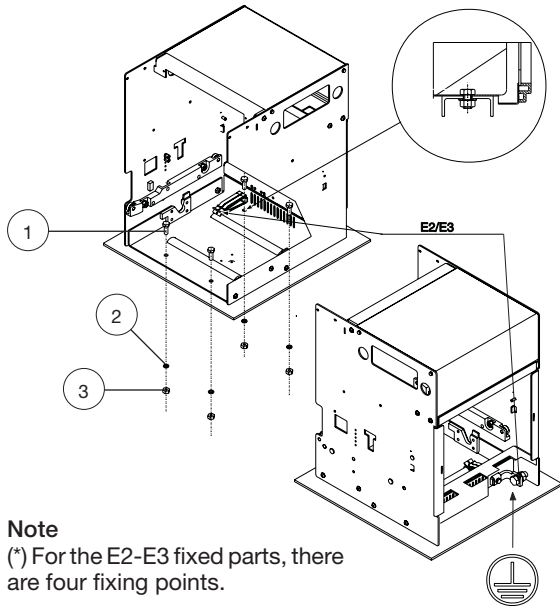

Fig. 12

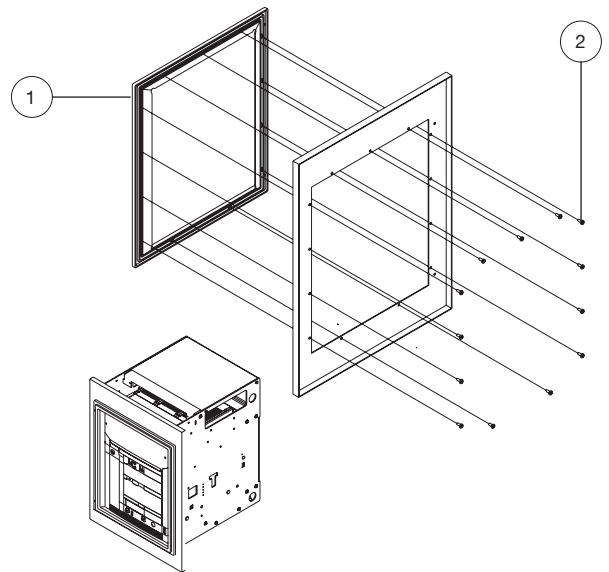

Fig. 13

Model	B2342	B2410		Apparatus	Emax VF	Scale
				Doc. No	1SDH000909R0001	Page No 9/66

5. Electrical connections

5.1. Connections to the power circuit

5.1.1. Shapes of the terminals

Fixed circuit-breaker

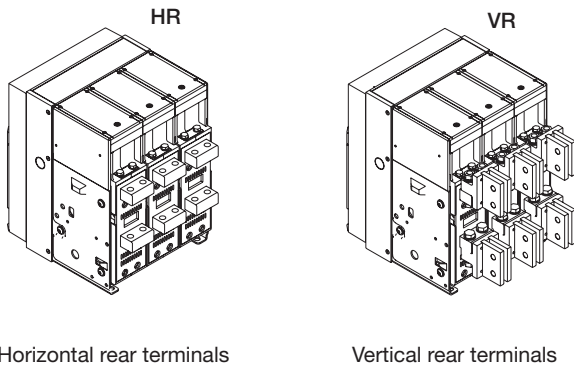

Fixed part for withdrawable circuit-breaker

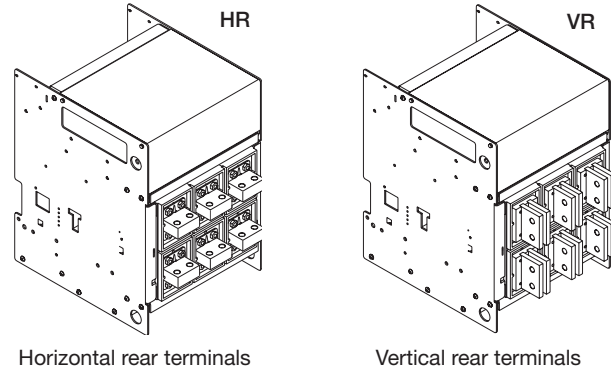

Fig. 14 _____

Fig. 15 _____

Note

The drawings are provided to show the type of terminal in graphic form. The exact shape of the terminals is given in the "Overall dimensions" chapter.

5.1.2. Examples of positioning the connection busbars according to the types of terminals

The connection busbars enable the connection between the terminals of the circuit-breakers and the busbars of the switchgear. Their sizing must be carefully studied by the switchgear designer. Some examples of possible constructions in relation to the shape and size of the circuit-breaker terminals are given in this paragraph. The various types of terminals are of constant dimensions for each size of circuit-breaker: it is normally advisable to exploit the whole contact surface of the terminal, so the width of the connection busbars should be the same as that of the terminal. Different connection capacities can be obtained by adjusting the thickness and number of busbars in parallel. In some cases, reductions in the width of the connection in relation to that of the terminal are allowable as shown in the following examples.

Circuit-breaker	I _u [A]	Vertical terminals			Busbar cross-section [mm ²]	Horizontal terminals			Busbar cross-section [mm ²]
		Continuous current-carrying capacity [A] (50÷60Hz)				Continuous current-carrying capacity [A](50÷60Hz)			
		35°C	45°C	55°C		35°C	45°C	55°C	
E2N/VF 12	1200	1200	1200	1200	1x(60x10)	1200	1200	1200	1x(60x10)
E2N/VF 16	1600	1600	1600	1600	2x(60x10)	1600	1600	1530	2x(60x10)
E3H/VF 20	2000	2000	2000	2000	2x(100x10)	2000	2000	2000	2x(100x10)
E3H/VF 25	2500	2500	2500	2500	2x(100x10)	2500	2450	2400	2x(100x10)

Fig. 16 _____

Positioning the first anchoring baffle of the busbars according to the short-circuit current

Anchoring to the switchgear

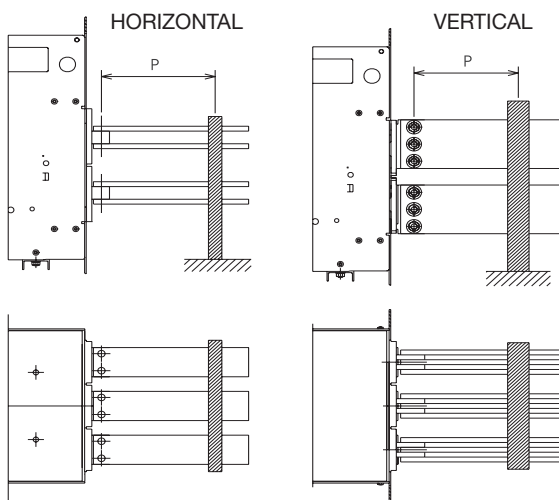

P	E2	E3
HORIZONTAL	250	150
VERTICAL	250	150

Fig. 17 _____

Model	B2342	B2410		Apparatus	Emax VF	Scale
				Doc. no.	1SDH000909R0001	Page No 10/66



5.1.3. Assembly procedure for the connection busbars

Check the state of the contact surfaces of the connections very carefully: they must be very clean with no burrs, dents or traces of rust which must be eliminated using a fine file or an emery cloth to prevent localized increases in temperature. On completion of the operation, remove all traces of grease or dust with a cloth soaked in a suitable solvent. When aluminium connections the contact surfaces must be tinned.

The connections must not exert any strain on the terminals in any direction.

Always insert a large-diameter flat washer and a spring washer between them (to spread the tightening pressure over a greater area). Make the contact between connection and terminal and tighten the fixing screws completely.

Always use two wrenches (so as not to strain the insulating parts excessively), applying the tightening torque indicated in Fig. 18. Check tightness after 24 hours.

		No. of screws for phase	No. of screws for neutral
	E2	2	2
	E3	3	3

M12 high strength screws
Tightening torque of the main terminals: 70 Nm

Fig. 18

5.2. Earthing

The fixed circuit-breaker and the fixed part of the withdrawable circuit-breaker have one or two terminals on the rear, marked with the special symbol, for connection to earth (Fig. 9 and Fig. 12).

Each terminal is complete with a bolt for fixing the connection. A conductor with a cross-section conforming to current standards must be used for the connection.

Before assembling the connection, clean and degrease the area around the screw.

After the assembly, tighten the bolt with a torque of 70 Nm.

5.3. Wiring the circuit-breaker auxiliary circuits

5.3.1. Interfacing elements for fixed circuit-breakers

A special terminal box is provided, fitted with screw terminals for connecting the auxiliary circuits.

The terminals are marked with alphanumerical identification codes as for the electrical circuit diagram.

The terminal box is identified by code XV on the electrical circuit diagram.

The terminal box is immediately accessible when the compartment door is open.

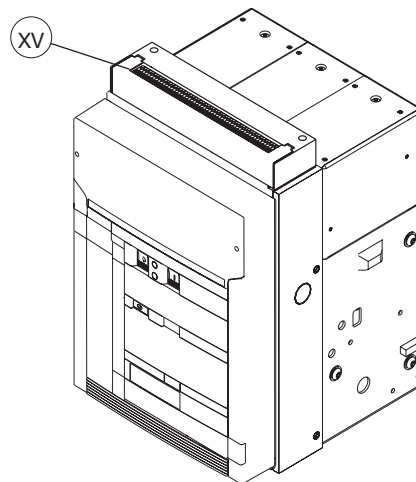

Fig. 19

Model	B2342	B2410		Apparatus	Emax VF	Scale
				Doc. No	1SDH000909R0001	Page No 11/66

5.3.2. Withdrawable circuit-breaker

For connection of the moving part to the auxiliary circuits, a connection with sliding contacts is available on the fixed part (see figure), identified by code X on the electrical circuit diagram.

The terminals of the fixed connector are immediately accessible when the compartment door is open.

Furthermore a terminal box identified by code XF is available for connecting the position contacts of the moving part in relation to the fixed part.

The connector and terminal box have screw terminals.

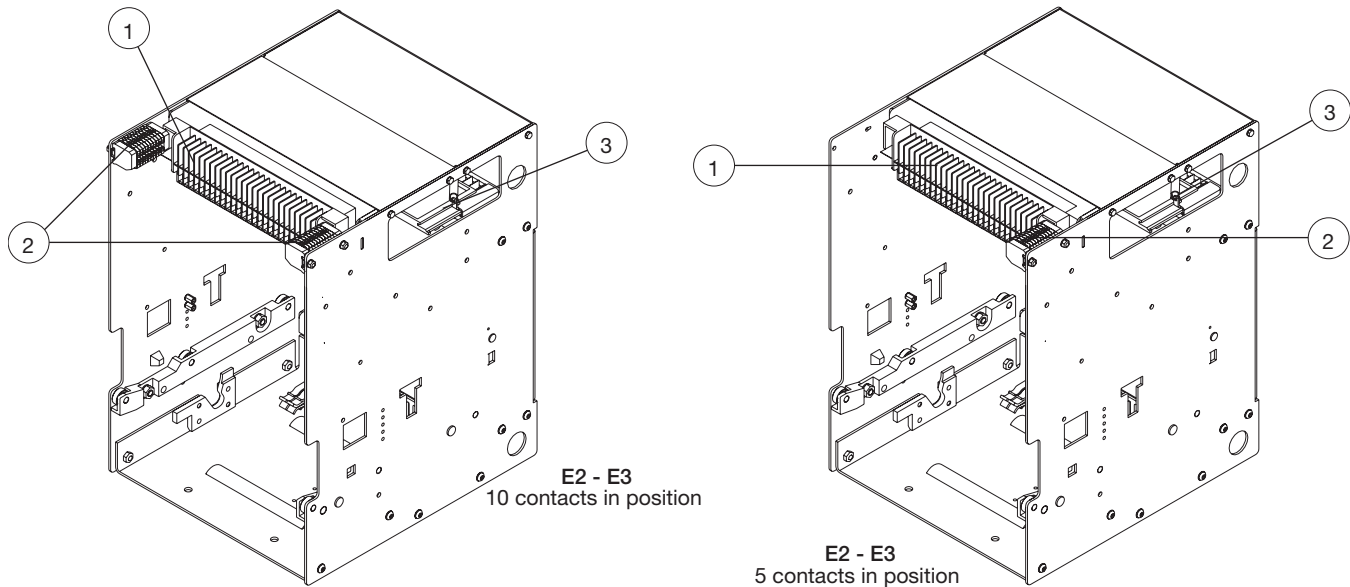

Caption

- 1 Sliding contacts (X)
- 2 Terminal box for position contacts (XF)
- 3 Position contacts

Fig. 20

5.4. Conversion of the auxiliary contacts or of the signalling contacts (disconnected - test isolated - connected), from normally closed (opening) to normally open (closing) or vice versa

The contacts are wired at the factory as shown on the electrical circuit diagram. If it is necessary to change their state for installation requirements, proceed as follows.

a) Auxiliary contacts

To access the auxiliary contacts, carry out the following operations:

- remove the front protection (3) of the release by taking action on the blocks (1) as shown in the figure
- remove the protection release (4) removing the side nuts (2) and then sliding the release out from the front of the circuit-breaker.

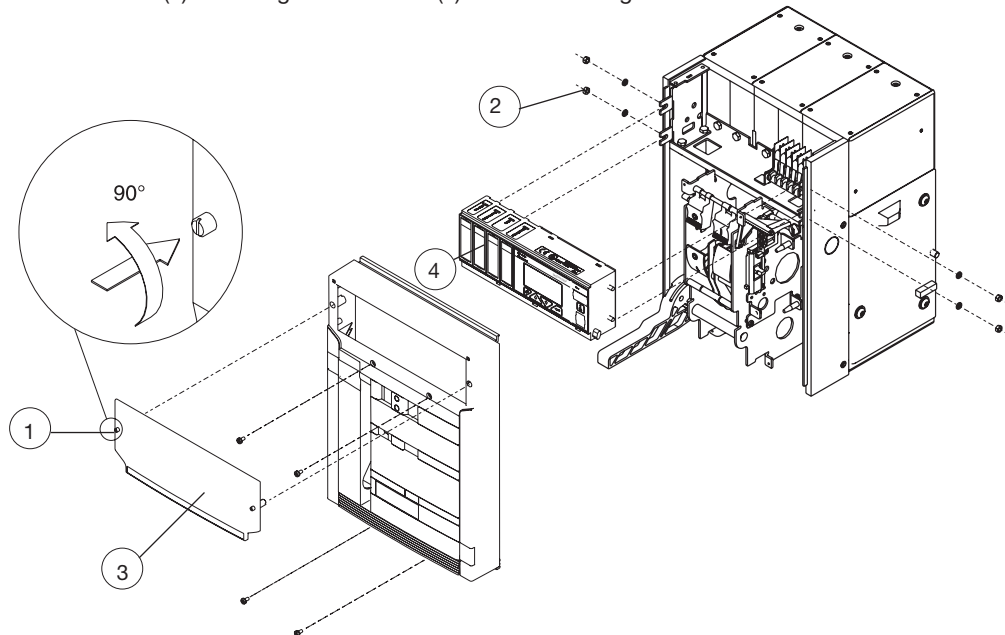
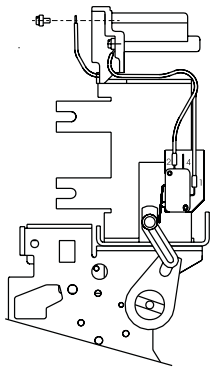

Fig. 21

Being of the two-way type (changeover contacts), the auxiliary contacts can be modified from break contacts to make contacts and vice versa simply by moving the output conductor from one position to the other, as shown in the figure.

Model	B2342	B2410		Apparatus	Emax VF	Scale
				Doc. no.	1SDH000909R0001	Page No 12/66



N.C. contact

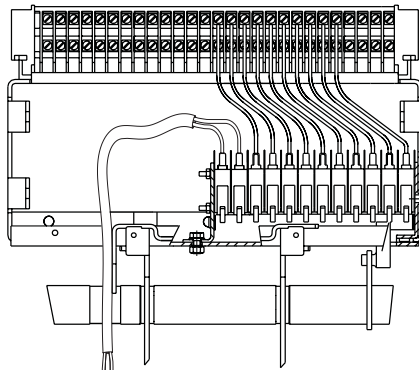

Sliding contacts

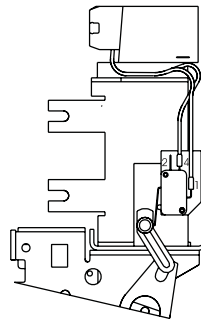

N.O. contact

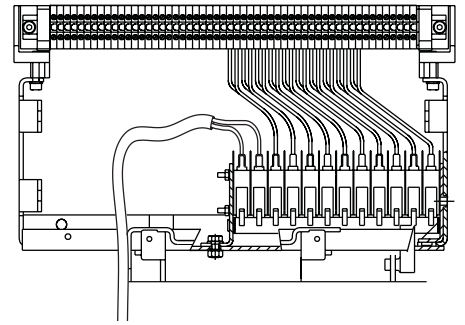

Terminal box

Fig. 22

b) Signalling contacts disconnected - test isolated - connected
 To change the state of the position contact, proceed in the same way as explained for the auxiliary contacts.

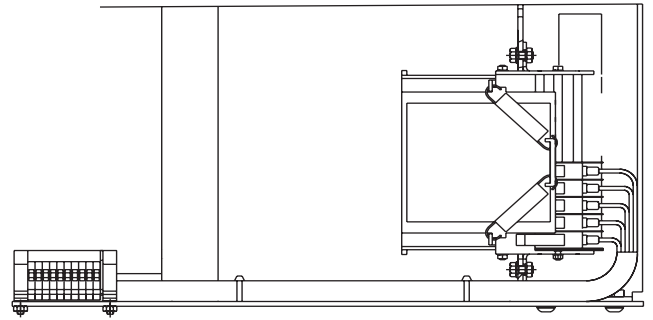

Model	B2342	B2410		Apparatus	Emax VF	Scale
				Doc. No	1SDH000909R0001	Page No 13/66

6. Putting into service

6.1. General procedures



WARNING: The external auxiliary power supply must be always provided to the terminal box (terminal: K1 and K2) to turn on the trip unit. Without the auxiliary power supply the trip unit does not work and the circuit breaker is not protected. It is recommended to use a backup battery to guarantee the presence of the Vaux or to add in the circuit breaker an undervoltage release (YU) to open the circuit breaker even when the auxiliary Vaux does not work.

- Check tightness of the power connections at the circuit-breaker terminals
- Carry out all the preparatory operations on the release
- Make sure that the value of the auxiliary circuit power supply voltage is between 85 and 110% of the rated voltage of the electrical applications
- Make sure that there is an adequate air circulation in the place of installation to avoid overheating
- Also carry out the checks specified in the following table.

Item inspected	Procedure	Positive check
1 Auxiliary power supply	Open the CB. Supply the trip unit at 24V DC.	The graphic display turns on. The word "ABB" scrolls in the bottom left-hand corner of the display.
2 Manual operating mechanism	Carry out some opening and closing operations (see the chapter 7.2). CAUTION When there is an undervoltage release, the circuit-breaker can only be closed after the release has been electrically energized.	The spring loading lever moves correctly
3 Geared motor (if any)	Supply the spring loading geared motor at the corresponding rated voltage. Carry out some closing and opening operations. Note. Supply the undervoltage release at the corresponding rated voltage (if any).	The springs are loaded correctly. The signals are correct. The geared motor stops with the springs loaded. The geared motor reloads the springs after each closing operation.
4 Undervoltage release (if any)	Supply the undervoltage release at the corresponding rated voltage and carry out the circuit-breaker closing operation. Disconnect voltage to the release. Supply the undervoltage release at the corresponding rated voltage and carry out the circuit-breaker closing operation.	The circuit-breaker closes correctly. The signals are correct. The circuit-breaker opens. The signal changes over..
5 Shunt opening release (if any)	Close the circuit-breaker. Supply the shunt opening release at the corresponding rated voltage.	The circuit-breaker opens correctly. The signals are correct..
6 Shunt closing release (if any)	Open the circuit-breaker. Loading the springs. Supply the shunt closing release at its rated voltage.	The circuit-breaker closes correctly. The signals are correct.
7 Circuit-breaker lock in the open position (with key or padlocks)	Open the circuit-breaker, turn the key and remove it from its seat. Attempt circuit-breaker closing operation.	Both manual and electrical closing are prevented.
8 Auxiliary contacts of the circuit-breaker	Insert the auxiliary contacts in suitable signalling circuits. Carry out some circuit-breaker closing and opening operations.	The signals are given correctly..
9 Auxiliary contacts for signalling circuit-breaker connected, test isolated and disconnected	Insert the auxiliary contacts in suitable signalling circuits. Then put the circuit-breaker in the connected, test isolated and disconnected position.	The signals due to the relative operations are given correctly..
10 Lock devices for circuit-breakers connected and disconnected. Interlocking devices between circuit-breakers side by side and one on top of another (if any)	Carry out the operating tests.	The locks function correctly.
11 For withdrawable circuit-breakers: racking -in/out device	Carry out some racking-in and out operations.	Racking-in operation: the circuit-breaker racks in correctly. The first turns of the crank handle do not meet with particular resistance.



WARNING: When undervoltage release has been activated by an undervoltage event, the circuit-breaker can only be closed after the release has been electrically energized. Ensure that an undervoltage condition existed at the time the release was activated. If not, investigate circuit-breaker and associated equipment to ensure they are in proper working order. If application is critical, investigate immediately.

Model	B2342	B2410		Apparatus	Emax VF	Scale
				Doc. no.	1SDH000909R0001	Page No 14/66

7. Instructions for use

7.1. Operating and signalling parts

- 1 Pushbutton for the manual opening operation
- 2 Lever for manual loading of the closing springs
- 3 Mechanical indicator for circuit-breaker open "O" and closed "I"
- 4 Mechanical indicator for protection release tripped (on request)
- 5 Pushbutton for the manual closing operation
- 6 Signalling device for springs loaded - unloaded
- 7 Operation counter (on request)
- 8 Key lock on the closing operation
- 9 Mechanical indicator for circuit-breaker connected, test isolated and disconnected
- 10 Seat for the racking-in/out lever
- 11 Lever releasing the racking-in/out operation
- 12 Key lock on the racking-in/out operation (on request)
- 13 Padlock on the manual closing operation (on request)
- 14 Padlock on the racking-in/out operation (on request)

Fixed circuit-breaker

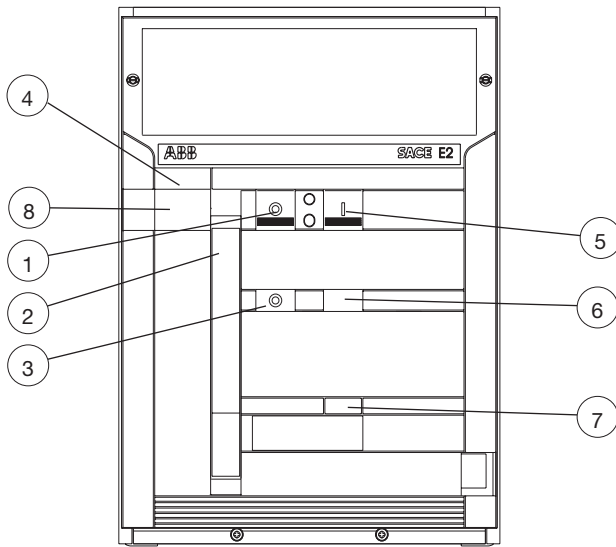

Withdrawable circuit-breaker

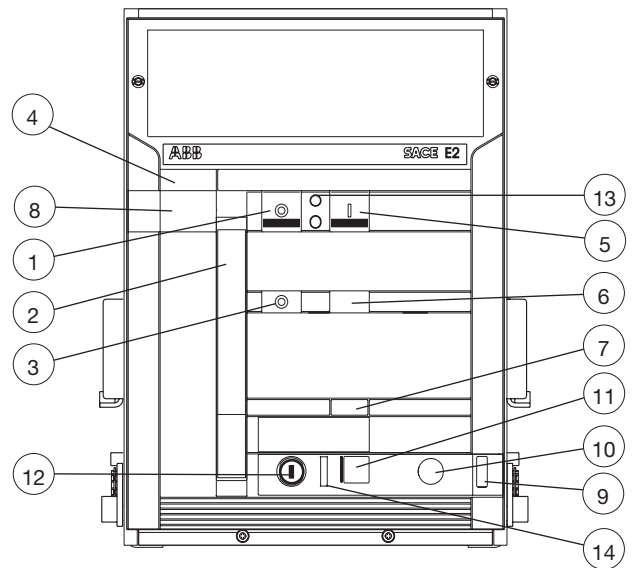

Fig. 23

Note

On request, a transparent cover can be installed on the front of the circuit-breaker to increase the degree of protection to IP54. The cover has a locking key.
As an alternative to the transparent cover, a protection can be mounted on the manual closing and opening controls, which only allows operation of the pushbuttons by means of a special tool.

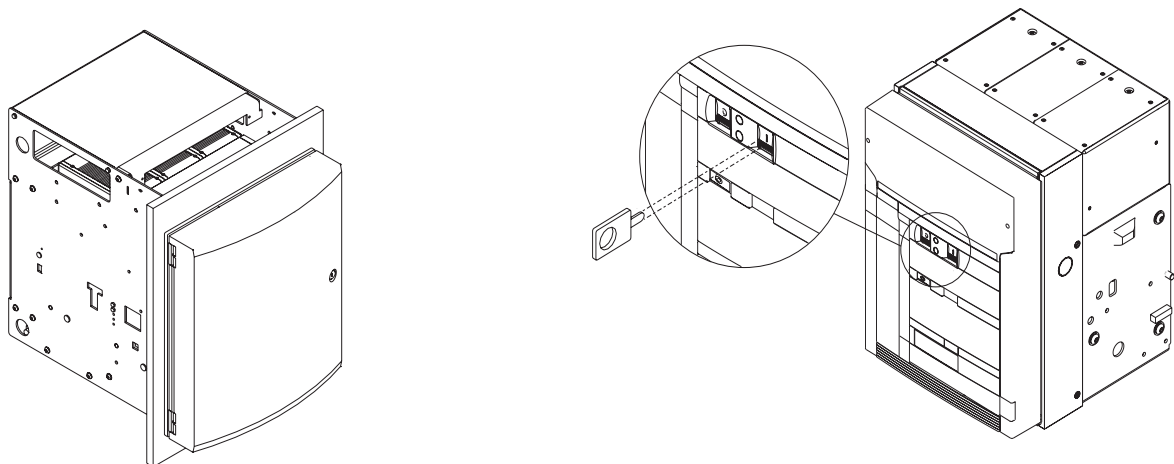

Fig. 24

Model	B2342	B2410		Apparatus	Emax VF	Scale
				Doc. No	1SDH000909R0001	Page No 15/66

7.2. Circuit-breaker closing and opening procedures

The operation of the circuit-breaker can be either manual or electrical.

a) Manual loading of the closing springs

- Make sure that the indicator (3) shows "O" (circuit-breaker open)
- Make sure that the indicator (6) is WHITE (springs unloaded)
- Repeatedly activate the lever (2) until the indicator (6) changes its color to YELLOW.

b) Electrical loading of the closing springs

The electrical loading of the circuit-breaker is possible when the following accessories (supplied on request) are present:

- geared motor for automatic loading of the closing springs
- shunt closing release
- shunt opening release.

The geared motor automatically reloads the springs after each closing operation until the yellow indicator appears (6, Fig. 25). When the power is cut off during loading, the geared motor stops and automatically starts reloading the springs again when the power returns. It is, in any case, always possible to complete the reloading operation manually.

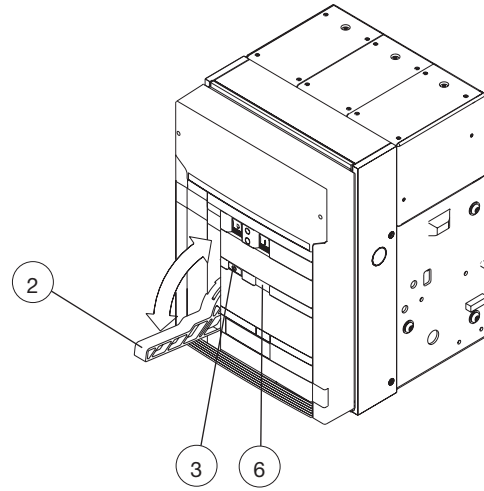

Fig. 25

c) Closing the circuit-breaker

The operation can only be carried out with the closing springs fully loaded. For manual closing, press the pushbutton (5) marked with the letter "I". When there is a shunt closing release, the operation can be carried out remotely by means of the special control circuit. The special indicator (3) changes to indicate "I" to signal that the circuit-breaker has closed. Furthermore, the indicator of the state of the springs (6) goes to the WHITE position. Even with the closing springs unloaded, the operating mechanism retains enough energy for the opening operation. The geared motor, if any, immediately starts the automatic spring reloading operation.

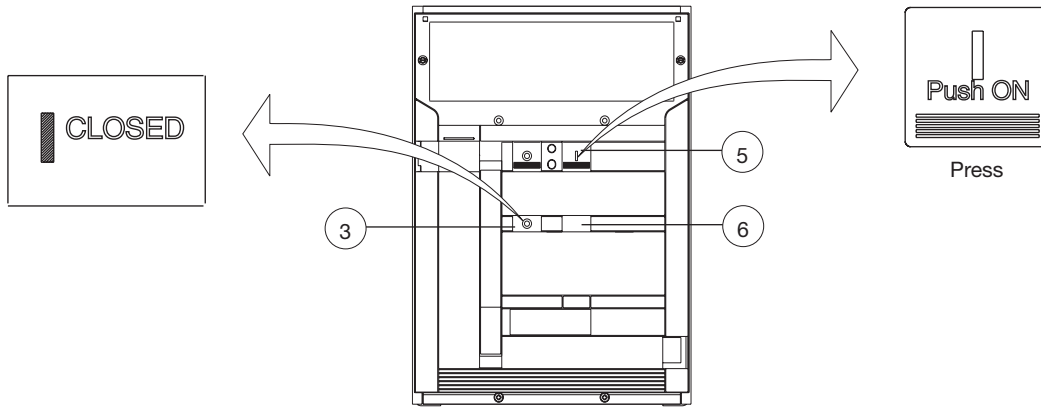

Fig. 26

d) Opening the circuit-breaker

For manual opening of the circuit-breaker, press pushbutton "O" (1). When there is a shunt opening release, the operation can also be carried out remotely by means of the special control circuit. Opening having taken place is signaled by the letter "O" appearing in the indicator (3).

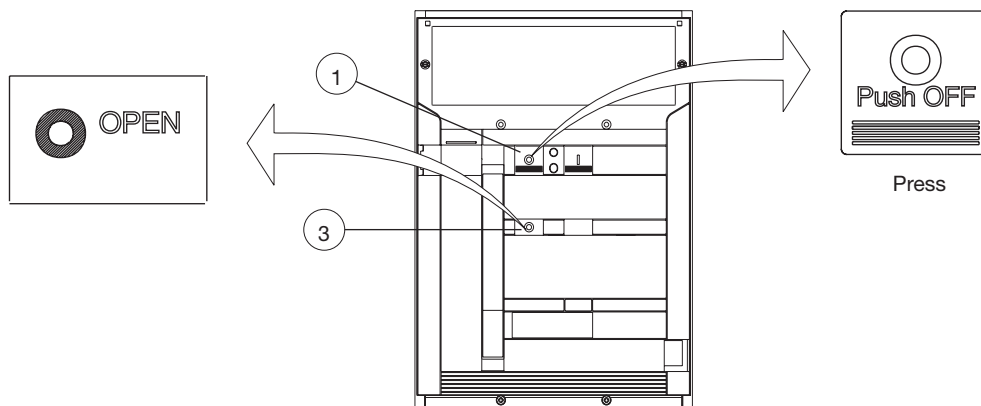

Fig. 27

Model	B2342	B2410		Apparatus	Emax VF	Scale
				Doc. no.	1SDH000909R0001	Page No 16/66

7.3. Racking-in/out operation

WARNING

- A) Open the circuit-breaker before carrying out any racking-in/out operation.
- B) The circuit-breaker (moving part) and fixed part are fitted with a lock which prevents the fixed part from being racked into the circuit-breakers with a different rated current: the congruence of the anti-racking-in lock must be checked by the operator before carrying out the racking-in operation to avoid any unnecessary stress.
- C) Before the racking-in operation, remove any padlock on the segregation shutter of the isolation terminals on the fixed part.



WARNING ELECTRICAL SHOCK HAZARD: Ensure that the circuit-breaker is either disconnected from all power sources and that the circuit breaker is open before performing any racking-in/out operation.

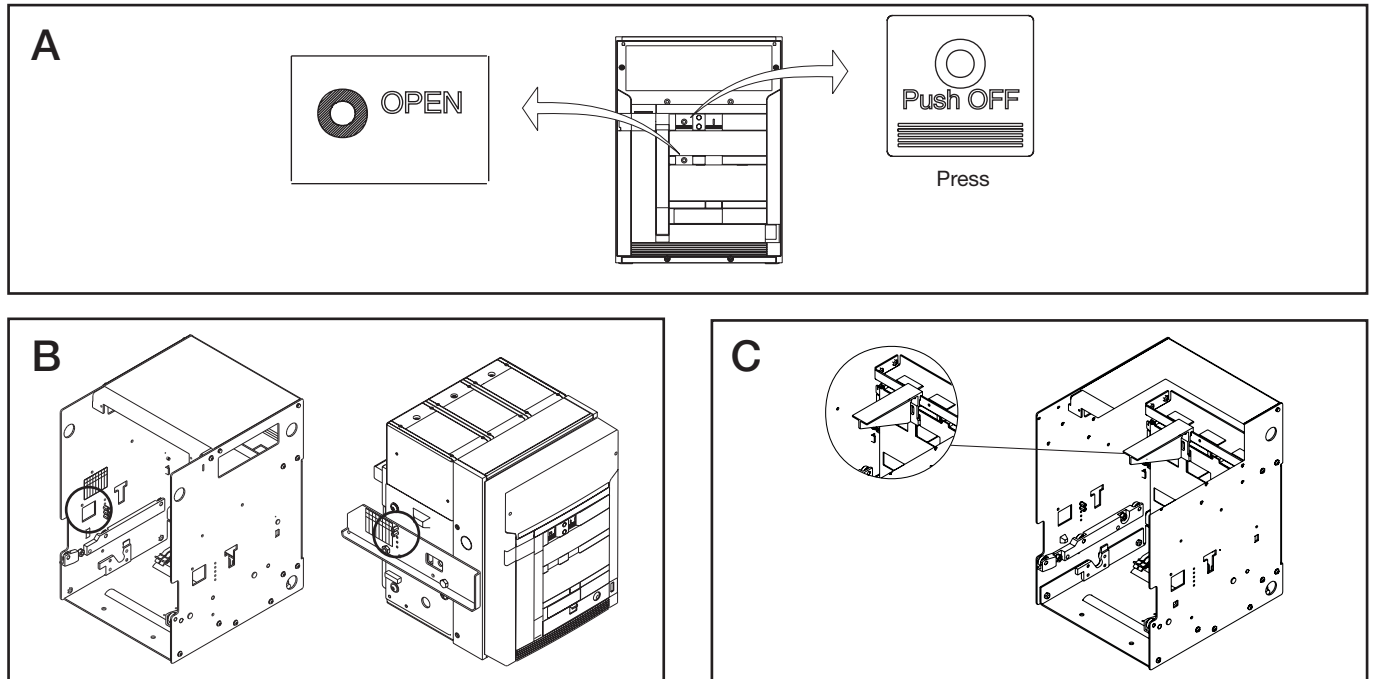

Fig. 28

NOTE

In relation to the fixed part, the circuit-breaker (moving part) can take up different positions, identified as follows:

- DISCONNECTED: the moving part is inserted in the fixed part WITHOUT any connection between the power terminals and WITHOUT coupling the sliding contacts for the auxiliary circuits: in this position all electrical operation of the circuit-breaker is prevented. On the front the indicator (9, Fig. 23) indicates DISCONNECTED. The switchgear compartment door can be closed.
- TEST ISOLATED: the moving part is inserted in the fixed part WITHOUT any connection between the power terminals, but WITH the sliding contacts coupled for the auxiliary circuits. In this position, the circuit-breaker can be operated for the offline tests. The indicator (9, Fig. 23) indicates TEST ISOLATED.
- CONNECTED: the moving part is fully inserted in the fixed part WITH the connection of both the power terminals and the sliding contacts for the auxiliary circuits. The circuit-breaker is operational. The indicator (9, Fig. 23) indicates CONNECTED.

a) Positioning the moving part in the fixed part in the DISCONNECTED position

Lift the moving part as shown in the paragraph (3) and insert it in the fixed part guide, tilting it as shown in figure 29.

The manual connection must allow the edge (E) of the circuit-breaker guide to slide under the blocks (D) of the fixed part. Remove the lifting devices.

Push the moving part as far as the stop in the fixed part. Close the compartment door.

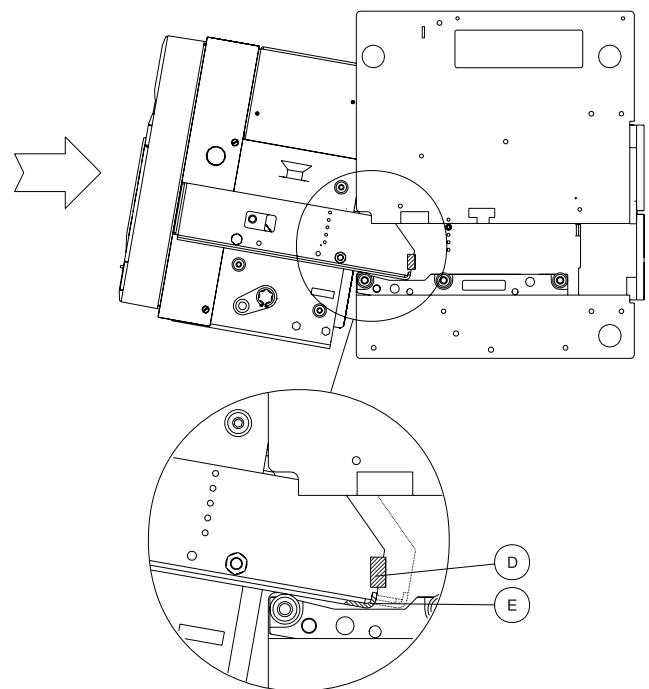

Fig. 29

Model	B2342	B2410		Apparatus	Emax VF	Scale
				Doc. No	1SDH000909R0001	Page No 17/66

b) Passing from the DISCONNECTED to the TEST ISOLATED position.

- Make sure that the indicator (9) is in the DISCONNECTED position.
- For the connection procedure, make sure that the key (12) is in the correct position and/or padlock (14), if any, has been removed.
- Make sure that the circuit-breaker is open.
- Push the moving part right into the fixed part.
- Lower the releasing lever (11).
- Insert the crank handle in the corresponding coupling (10).
- Proceed to turn the crank handle clockwise until the TEST ISOLATED indication appears on the indicator (9). During the initial turns, the crank handle must oppose no any particular resistance to rotation.
- Should it be necessary to carry out offline circuit-breaker operations, the crank handle must be removed.

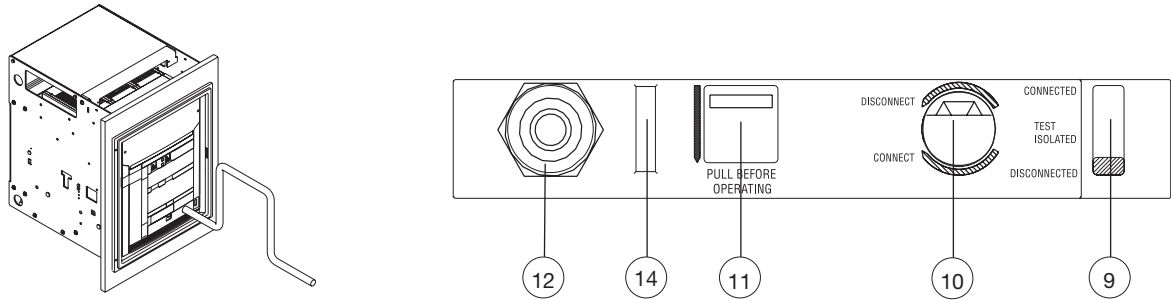

Fig. 30

c) Passing from the TEST ISOLATED position to the CONNECTED position

- Make sure that the circuit-breaker is open.
- Lower the releasing lever (11).
- Insert the crank handle in the corresponding coupling (10).
- Proceed to turn the crank handle clockwise until the CONNECTED indication appears on the indicator (9).
- Remove the crank handle to enable the circuit-breaker to close.

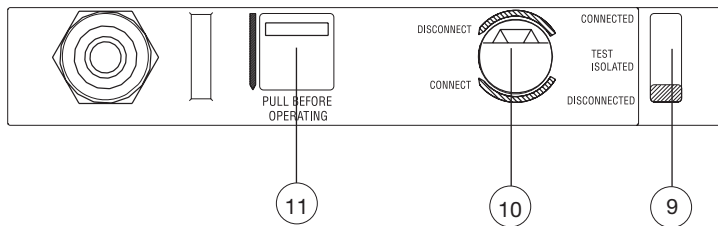

Fig. 31

d) Passing from the CONNECTED position, to the TEST ISOLATED position, to the DISCONNECTED position

- Repeat the connection procedures changing the direction for turning the crank handle to anti-clockwise. Open the door in the disconnected position.

Model	B2342	B2410		Apparatus	Emax VF	Scale
				Doc. no.	1SDH000909R0001	Page No 18/66

8. Maintenance

8.1. Warning



WARNING: Before carrying out any maintenance task, you must:

- Open the circuit-breaker and check that the operating mechanism springs are unloaded;
- In the case of a withdrawable circuit breaker, remove the circuit breaker from the fixed part before working on it;
- For action on fixed version circuit-breakers or on fixed parts disconnect the power circuit and the auxiliary circuits and visibly earth the terminals both on the power supply side and on the load side;
- Make safe in compliance with current laws.



WARNING ELECTRICAL SHOCK HAZARD: Shock Hazard or Injury.

ABB declines all responsibility for damage to things and injury to people due to failure to comply with the instructions contained in this document. Maintenance tasks must be performed by qualified staff with a detailed knowledge of the unit.

8.2. Maintenance programme

8.2.1. Circuit-breaker life

With regular maintenance, SACE Emax circuit-breakers, either with or without opening or closing releases, can withstand the following operation without replacement of parts. ⁽¹⁾

Rated uninterrupted current I _u (40 °C) [A]	Mechanical life ⁽²⁾		Electrical life (50Hz/60Hz) ^{(2) (3)}	
	No. of operations x 1000	Frequency operations/hour	690 V ~ No. of operations x 1000	Frequency operations/hour
E2N/VF	1200	12	30	10
	1600	12	30	10
E3H/VF	2000	10	30	7
	2500	10	30	7
LTT Low temperature version				
E2 LTT ⁽⁴⁾	1200 - 1600	8	30	8
E3 LTT ⁽⁴⁾	2000 - 2500	8	30	7

(1) Data referring to standard installation conforming to product standards. For other applications, please consult ABB Sace.

(2) Extreme atmospheric conditions, polluted atmosphere or vibrations may shorten the application's life. Please consult ABB Sace.

(3) For different frequency please consult ABB Sace.

(4) Switch disconnectors

8.2.2. Maintenance program

The table shows the maintenance intervals and the frequency of periodical intervention and routine maintenance tasks. The following rules should also be followed:

- Even circuit-breakers that are little used or remain on or off for long periods should be subject to the maintenance programme.
- The SACE PR122/VF release enable the number of operations performed by the circuit breaker in use to be displayed at any moment on the display.
- During operation, inspect the circuit-breaker from the outside to check for dust, dirt or damage of any kind.

Maintenance operations	Interval	
	Installation in normal environments	Installation in dusty environments ^{(1)/(2)} and low temperature environment ⁽³⁾ [(1) = level of measured dust > 1 mg/m ³]
First level	One year or 20% mechanical life or 20% electric life	6 months or 10% mechanical life or 10% electric life
Second level	Three years or 50% mechanical life or 50% electric life or after intervention on short circuit	18 months or 25% mechanical life or 25% electric life or after intervention on short circuit

(1) Data referring to standard installation in accordance with product standards. For other applications, please consult ABB Sace.

(2) Extreme atmospheric conditions, polluted atmosphere or vibrations may shorten the life of the application. Please consult ABB Sace.

(3) Emax LTT Low temperature environment application.

8.3. First level maintenance operations

8.3.1. Preliminary operations:

- open the circuit-breaker and check that the control springs are unloaded
- in the case of a withdrawable circuit breaker, remove the circuit breaker from the fixed part before working on it



WARNING: before working on fixed circuit-breakers or on fixed part, disconnect the supply to the power circuit and to the auxiliary circuits and earth the terminals in a visible manner both on the supply and on the load side.

8.3.2. Checks and general cleaning:

- Check that the apparatus (switching part) is clean, removing dust and any traces of excess oil or grease using dry and clean rags (possibly using non-corrosive detergent).

Model	B2342	B2410		Apparatus	Emax VF	Scale
				Doc. No	1SDH000909R0001	Page No 19/66

- For excessive deposits, a dilutant such as Henkel 273471 or the equivalent can be used.
- Check that the rating plates of the apparatus are in place.
- Clean the rating plates with dry and clean cloths.
- Eliminate any dust, mould, traces of condensation or oxidation also inside the fixed part if the circuit-breaker is a withdrawable version.
- Check that there are no foreign bodies in the circuit-breaker cabinet.

8.3.3. Circuit-breaker connections and connections between the circuit-breaker and the control panel

- Use brushes and dry cloths to remove any dust or dirt (if necessary, use non-corrosive detergent.)
- For excessive deposits, a dilutant such as Henkel 273471 or the equivalent can be used.
- Check that there are no traces of overheating on the terminals. This problem is due to discolouring of the contact parts; the contact parts are normally silver in colour.
- Check that the bolts fixing the connections to the terminals are tight (M12 - 70Nm).

WARNING: before working on fixed circuit-breakers or on fixed part, disconnect the supply to the power circuit and to the auxiliary circuits and earth the terminals in a visible manner both on the supply and on the load side.

- Check that the connecting screws of the cables of the terminal boards are tight (0.7 Nm).

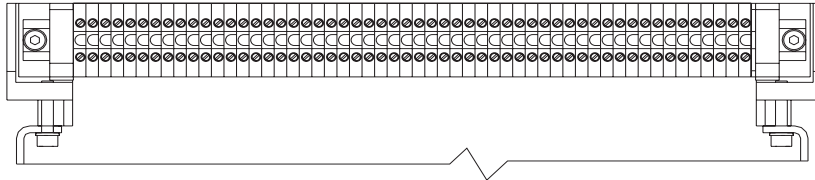

Fig. 32

8.3.4. Dismantling tab and cap

- The tab (1) of the release by rotating the screws (2) as shown in figure 33.
- Remove the front cap (3) by loosening the four screws (4).

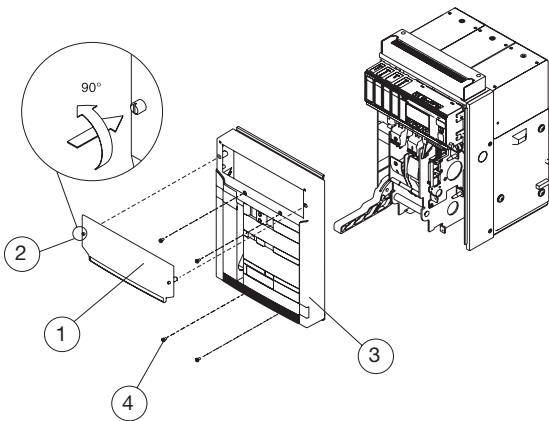

Fig. 33

- If there is an undervoltage release, remove the coils support and release the control springs, closing and opening the circuit-breaker.

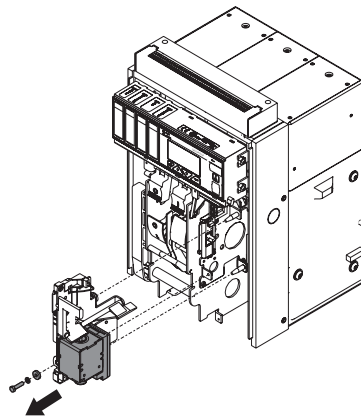

Fig. 34

Model	B2342	B2410		Apparatus	Emax VF	Scale
				Doc. no.	1SDH000909R0001	Page No 20/66

8.3.5. Mechanical control

- Clean at the points indicated in figure 35. For excessive deposits, a dilutant such as Henkel 273471 or the equivalent can be used.
- Lubricate, at the points indicated in fig. 35, the opening-closing shafts and hooks with MOBILGREASE 28 (EXXON MOBIL).
- Check that the opening and closing shafts are free to rotate.

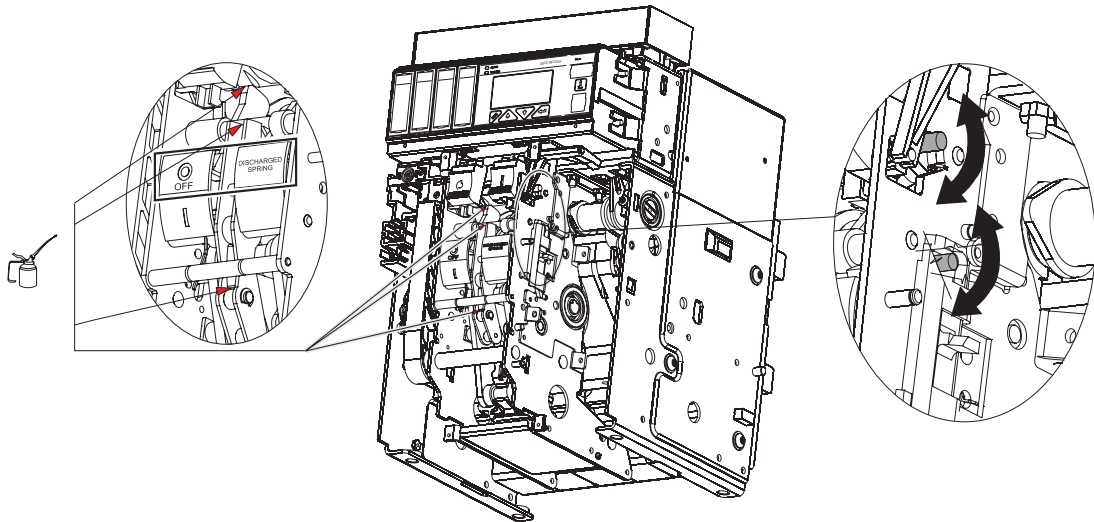

Fig. 35

8.3.6. Electrical and mechanical accessories

- Check that the accessories are fixed to the circuit-breaker
- Check that the electrical accessories are connected to the circuit-breaker
- Reduction gear: after 10000 operations check brushes for wear and replace the reduction gear if necessary.
- Check that the releases (SOR-UVR-SRC) are in good condition (no excessive wear, overheating, breakages) Fig. 36.
- Check that the mechanical operation counter is operating correctly (if applicable) by running an operation on the circuit-breaker.

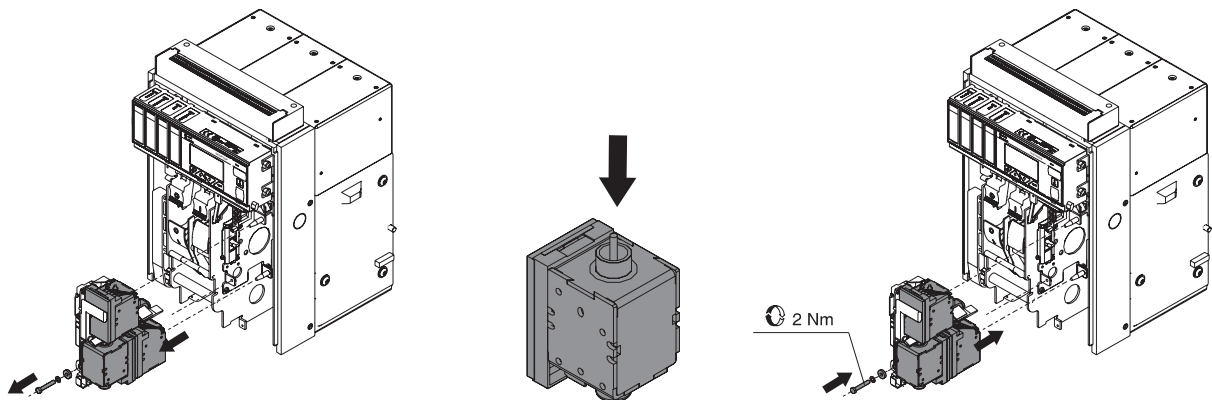

Fig. 36

8.3.7. Protection releases

- Supply the protection release from a PR030/B battery unit.
- Check that the protection release is working correctly: run "Trip Test" and "Autotest" for release.
- Use release PR122/VF to check that there are no alarms on the display and via front LEDs.
- Check that the cables are correctly connected to the release modules and to the release (if applicable).
- On PR122/VF check the wear percentage to the circuit-breaker contacts.
- At the end, remove the battery unit PR030/B from the relay.

8.3.8. Test with Ekip Connect (optional)

- Connect Ekip T&P unit on a PC and the cable adapter to the relay to be tested.
- Run the Ekip Connect software on the PC .
- Once the connection between the relay and PC has been installed, check that there are no alarm signals from the relay; otherwise, consult the paragraphs 'Error Messages' and/or 'Troubleshooting' in this manual.
- In normal operating conditions the trip test and the autotest can be run (depending on the type of relay); for future checks, we advise inserting the current date in the User Data and/or Tag Name area. These data will be stored inside the relay.
- Remove the Ekip T&P cable adapter from the relay.

Model	B2342	B2410		Apparatus	Emax VF	Scale
				Doc. No	1SDH000909R0001	Page No 21/66

8.3.9. Maintenance operations; final checks

- Refit all parts and always reconnect the auxiliary supply.
- Refit the cap as indicated in figure 37.

- Return the movable part to the TEST-ISOLATED position.
- Use the different auxiliaries in turn to run the following 10 operations:
 - Opening (both local and remote as applicable)
 - Closing (both local and remote as applicable)
 - Release by trip test from the relay

- Check the operations according to this sequence:
 - Open - Springs unloaded
 - Open - Springs loaded
 - Closed - Springs unloaded
 - Closed - Springs loaded

- Check operation of the accessories, if present
- Check operation of reduction gear (if present)
- Check operation of undervoltage release (if present)
- Check operation of opening release (if present)
- Check operation of closing release (if present)
- Check operation of auxiliary contacts of circuit-breaker (if present)
- Check operation of lock of circuit-breaker in open position (with key or padlocks) (if present)

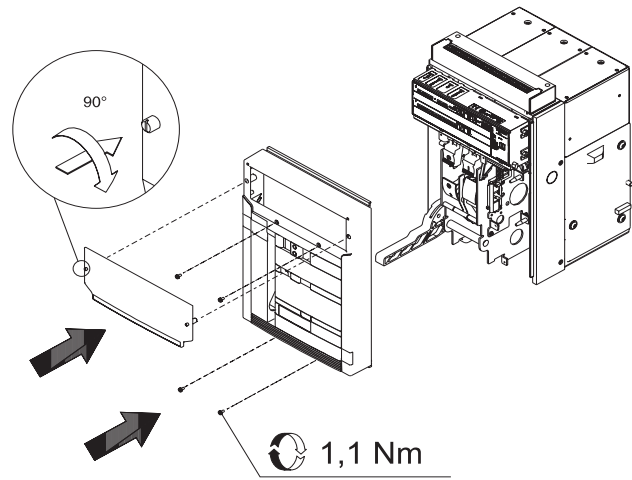

Fig. 37

- VAUX: check the presence of auxiliary power supply 24V DC on relay.

8.3.10. Interlock

- Check that the interlock devices have been correctly installed and operate correctly between adjacent and superimposed circuit-breakers (if present). The operating test cannot be run in the Test or Extracted positions.

8.4. Second level maintenance operations

8.4.1. Preliminary operations:

- open the circuit-breaker and check that the control springs are unloaded
- in the case of a withdrawable circuit breaker, remove the circuit breaker from the fixed part before working on it



WARNING: before working on fixed circuit-breakers or on fixed part, disconnect the supply to the power circuit and to the auxiliary circuits and earth the terminals in a visible manner both on the supply and on the load side.

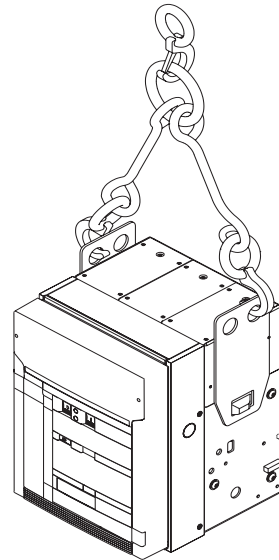

Fig. 38

8.4.2. General checks and cleaning:

- Check the cleanliness of the apparatus (switching part), removing dust and any traces of excess oil or grease with dry cloths (if necessary, use non-corrosive detergent)
- For excessive deposits, a dilutant such as Henkel 273471 or the equivalent can be used.
- Check that the rating plates of the apparatus are in place
- Clean the rating plates with dry and clean cloths
- Eliminate any dust, mould, traces of condensation or oxidation also inside the fixed part if the circuit-breaker is a withdrawable version.
- Check that there are no factors such as overheating or cracks that may compromise circuit-breaker insulation
- Check the circuit-breaking couple for damage (for the fixed part, see feature A, fig 39).
- The couple must be silver in colour without trace of erosion or smoke
- Check that there are no foreign bodies in the circuit-breaker cabinet
- Check that the fixing screws are tightened on the fixed side to the control panel (M8 - 25Nm).

Model	B2342	B2410		Apparatus	Emax VF	Scale
				Doc. no.	1SDH000909R0001	Page No 22/66

8.4.3. Connections between the circuit-breaker and the control panel

- Use brushes and dry cloths to remove dust or dirt on the insulating parts (if necessary, use non-corrosive detergent - For excessive deposits, a dilutant such as Henkel 273471 or the equivalent can be used).
- Check that there are no traces of overheating on the terminals. The problem is detected by discoloration of the parts in contact; the contact points are normally silver in colour.
- Check the tightness of the bolts fixing the connections to the terminals (M12 - 70Nm).



WARNING: before working on fixed circuit-breakers or on fixed part, disconnect the supply to the power circuit and to the auxiliary circuits and earth the terminals in a visible manner both on the supply and on the load side.

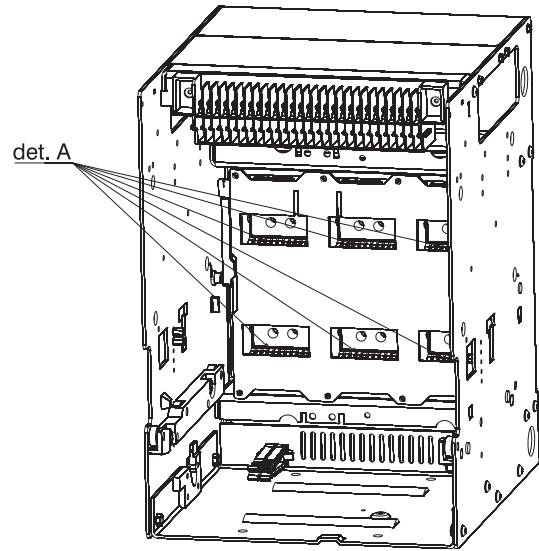

Fig. 39

- Check that the connecting screws of the cables of the terminal boards are tight (0.7 Nm).

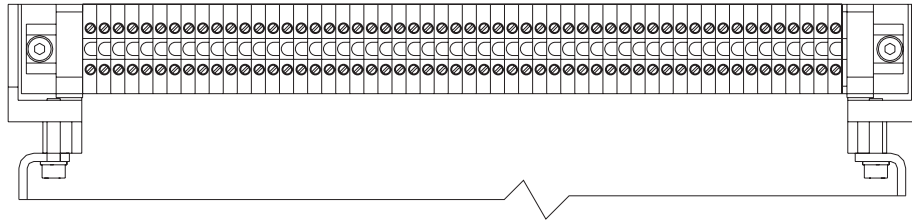

Fig. 40

8.4.4. Dismantling the tab, cap and arcing chambers

- Remove the flange (1) of the release, turning the screws (2) as shown in the figures
- Remove the front escutcheon plate (3) by removing the four screws (4)
- Remove the arcing chambers (5) by removing the screws (6).

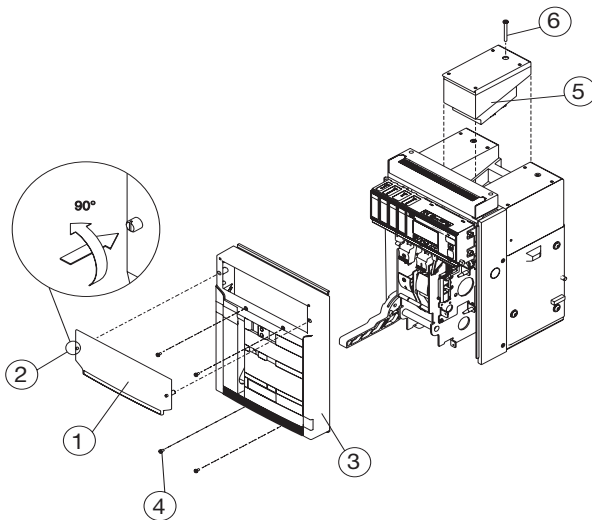

Fig. 41

Model	B2342	B2410		Apparatus	Emax VF	Scale
				Doc. No	1SDH000909R0001	Page No 23/66

- If there is an undervoltage release, dismantle the coil support and unload the control springs by opening and closing the circuit-breaker.

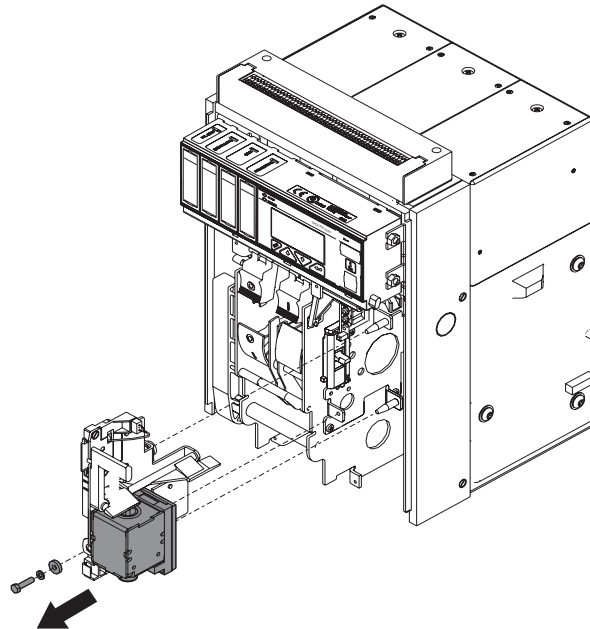

Fig. 42

8.4.5. Mechanical control

- Cleaning (for excessive deposits, a dilutant such as Henkel 273471 or the equivalent can be used) and lubricate, at the points indicated in fig. 43, part A, as for First Level, the opening and closing shafts and hooks with MOBILGREASE 28 (EXXON MOBIL).
- Cleaning (for excessive deposits, a dilutant such as Henkel 273471 or the equivalent can be used) and lubricate with MOBILGREASE 28 (EXXON MOBIL) the supports of the operating shaft, including those on the sides of the circuit-breaker (see fig. 43 part B).
- Check that the opening and closing shafts are free to rotate.

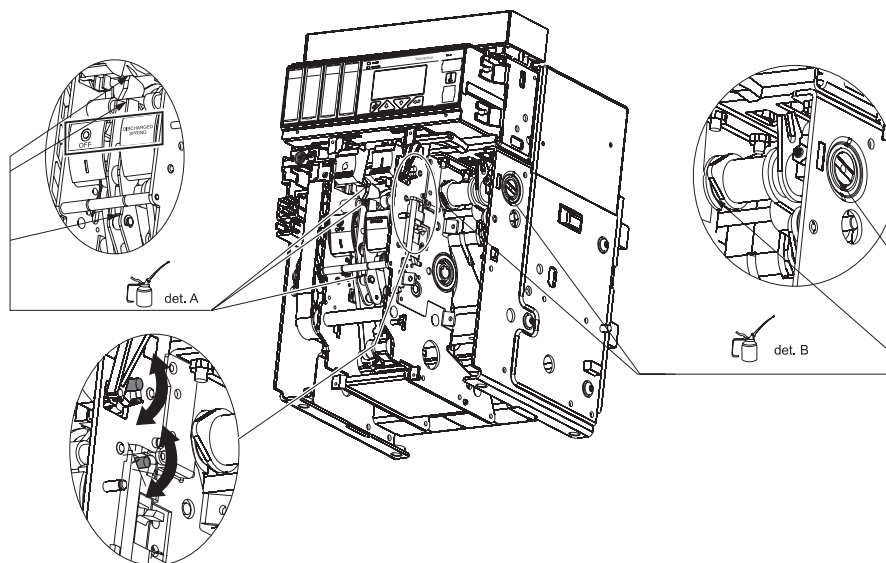

Fig. 43

- In the case of deformed or oxidated springs, missing rings or serious wear to the controls contact ABB Sace (*).
- (*) Subject to the customer's approval, ABB can replace "A" type parts.

8.4.6. Electrical and mechanical accessories

- Check that the accessories are tightly fixed to the circuit-breaker.
- Check that the electrical accessories are wired correctly to the circuit-breaker.
- Reduction gear: after 10000 operations check brushes for wear and replace the reduction gear if necessary.
- Check that the releases (YO, YU, YC) are in good condition (no excessive wear, overheating, breakages) fig 44.

Model	B2342	B2410		Apparatus	Emax VF	Scale
				Doc. no.	1SDH000909R0001	Page No 24/66

- Check that the mechanical operation counter is operating correctly (if applicable) by running an operation on the circuit-breaker.

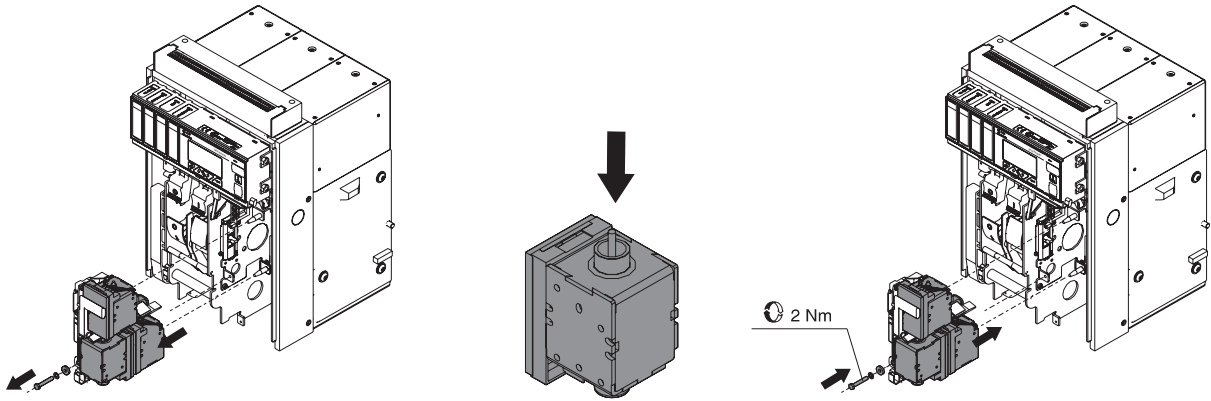
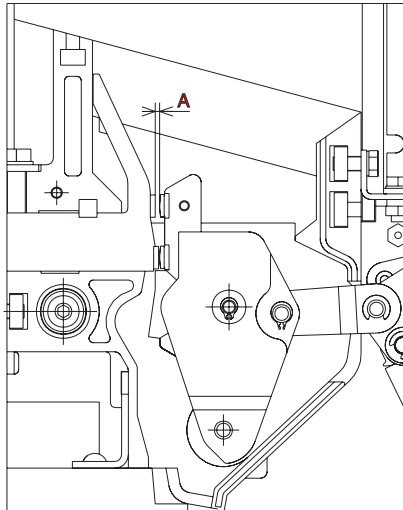

Fig. 44

8.4.7. Checking contact wear

With the circuit-breaker open and arcing chambers removed:

- 1) Check the state of the blowout magnet chambers: the body of the chamber must be undamaged and the plates must not be corroded or damaged.
- 2) Remove the dust with compressed air and remove traces of smoke and any waste with a brush of appropriate type.
- 3) Check the state of the contacts.
- 4) Visually check that the main plates and the blowout magnets are in place.
- 5) Check for oxidation or beads and if they are detected, request help from the qualified ABB technician (*).
- 6.1) Check the blowout magnets distances (distance A fig 45).



Circuit Breaker	A
E2 - E3	> 1mm --> OK

Fig. 45

- 6.2) close the circuit-breaker and check the gap A
 - If the gap A is not correct, contact ABB Sace (*)
 - If the gap A is correct, open the circuit breaker and refit the arc chambers.

(*) Subject to the customer's approval, ABB can replace "A" type parts.

8.4.8. Protection releases

- Supply the protection release with a PR030/B battery unit.
- Check operation of the protection release: release test with "Trip Test" and "Autotest".
- Use release PR122/VF to check for the absence of alarms on the display and via front LEDs.
- Check correct wiring of the cables to the modules of the release and to the release (if applicable).
- On PR122/VF check the percentage of wear to the contacts of the circuit-breaker.
- At the end, remove the battery unit PR030/B from the relay.

8.4.9. Test with Ekip Connect (optional)

- Connect Ekip T&P unit on a PC and the cable adapter to the relay to be tested.
- Run the Ekip Connect software on the PC .

Model	B2342	B2410		Apparatus	Emax VF	Scale
				Doc. No	1SDH000909R0001	Page No 25/66

- Once the connection between the relay and PC has been installed, check that there are no alarm signals from the relay; otherwise, consult the paragraphs 'Error Messages' and/or 'Troubleshooting' in this manual.
- In normal operating conditions the trip test and the autotest can be run (depending on the type of relay); for future checks, we advise inserting the current date in the User Data and/or Tag Name area. These data will be stored inside the relay.
- Remove the Ekip T&P cable adapter from the relay.

8.4.10. Maintenance operations; final checks:

- Refit each part and always reconnect the auxiliary supply.
- Refit the cap as indicated in figure 46.

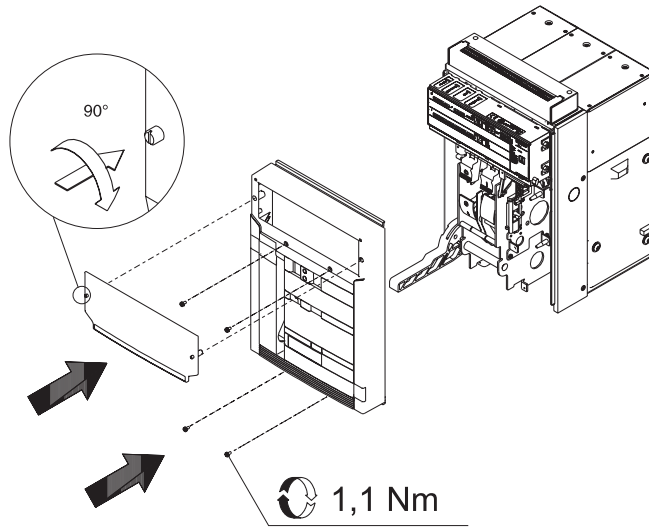

Fig. 46

- Return the movable part to the position TEST-ISOLATED.
 - Use the different auxiliaries in turn to run the following 10 operations:
 - opening (both local and remote as applicable)
 - closing (both local and remote as applicable)
 - release by trip test from the relay
 - Check the operations according to this sequence:
 - Open - Springs unloaded
 - Open - Springs loaded
 - Closed - Springs unloaded
 - Closed - Springs loaded
 - Check operation of the accessories, if present
 - Check operation of reduction gear (if present)
 - Check operation of undervoltage release (if present)
 - Check operation of opening release (if present)
 - Check operation of closing release (if present)
 - Check operation of auxiliary contacts of circuit-breaker (if present)
 - Check operation of lock of circuit-breaker in open position (with key or padlocks) (if present)
- VAUX: check the presence of auxiliary power supply 24V DC on relay.

8.4.11. Interlock

Check that the interlock devices have been correctly installed and operate correctly between adjacent and superimposed circuit-breakers (if present). The operating test cannot be run in the Test or Extracted positions.

8.4.12. Withdrawable

In the withdrawable versions, check the operational efficiency of the insertion and extraction of the circuit-breakers from the fixed part, performing the movement by means of the operating lever supplied and checking that the shutters for segregating the parts carrying live voltage are closed after extraction. Check correct operation of the inserted and extracted circuit-breakers lock devices (if present).

Model	B2342	B2410		Apparatus	Emax VF	Scale
				Doc. no.	1SDH000909R0001	Page No 26/66

10. Accessories

10.1. Electrical accessories

Shunt opening/closing (YO/YC) and second shunt opening release (YO2)

This allows remote opening or closing control of the apparatus. Given the characteristics of the circuit-breaker operating mechanism, opening (with the circuit-breaker closed) is always possible, whereas closing is only possible when the closing springs are loaded. Most of the releases can operate with either direct or alternating current. This release carries out an instantaneous service (*), but can be supplied permanently (**).

In uses where the shunt closing release is supplied permanently, to carry out the circuit-breaker reclosing operation after opening, it is necessary to momentarily de-energize the shunt closing release (the circuit-breaker operating mechanism reclosing is, in fact, fitted with an antipumping device).

In some versions it is necessary to have a very high degree of safety for the remote opening control of the circuit-breaker, and, in particular, the duplication of the control circuit of the shunt opening release is required. In order to achieve this, you can fit the SACE Emax circuit-breakers with a second shunt opening release. The second shunt opening release is located in the same seat as the undervoltage release and its technical characteristics are the same as the standard shunt opening release

(*) In the case of instantaneous service, the minimum duration of the current impulse must be 100 ms.

(**) In the case of permanent power supply to the shunt opening release, you must wait for at least 30 ms before giving the opening control to the shunt closing release.

Reference figures in the electrical circuit diagrams: YO (4) - YC (2) - YO2 (8)

Power supply (Un)	24 V DC	Operating limits (CEI EN 60947-2 Standards)	(YO-YO2) : 70...110% Un
	30 V AC/DC		(YC) : 85...110% Un
	48 V AC/DC	Inrush power consumption (Ps)	DC = 200 W
	60 V AC/DC	Inrush power time ~100 ms	AC = 200 VA
	110-120 V AC/DC	Continuous power (Pc)	DC = 5 W
	120-127 V AC/DC		AC = 5 VA
	220-240 V AC/DC	Opening time (YO - YO2)	(max) 60 ms
	240-250 V AC/DC	Closing time (YC)	60±10 ms
	380-400 V AC	Insulation voltage	2500V 50 Hz (for 1 min.)
	440 V AC		

Undervoltage release (YU)

The undervoltage release opens the circuit-breaker in the case of a considerable drop or lack of its power supply voltage. It can be used for remote tripping (by means of normally closed type pushbuttons), as a lock on closing or to control the voltage in the primary and secondary circuits. The release power supply is therefore branched on the supply side of the circuit-breaker or from an independent source. Circuit-breaker closing is only allowed with the release powered (the closing lock is carried out mechanically). Most releases can operate with either direct or alternating current.

Power supply (Un)	24 V DC
	30 V AC/DC
	48 V AC/DC
	60 V AC/DC
	110-120 V AC/DC
	120-127 V AC/DC
	220-240 V AC/DC
	240-250 V AC/DC
	380-400 V AC
440 V AC	

Circuit-breaker opening takes place with power supply voltage values of the release equivalent to 35 - 70% Un.

Circuit-breaker closing is possible with power supply voltage of the release equivalent to 85-110% Un.

it can be fitted with a signalling contact for undervoltage release energized (C. aux YU)..

Reference figures in the electrical circuit diagrams: YU (6)

Inrush power consumption (Ps):	DC = 200 W
	AC = 200 VA
Continuous power (Pc):	DC = 5 W
	AC = 5 VA
Opening time (YU):	≤80 ms
Insulation voltage	2500V 50 Hz (per 1 min.)

Time delay device for undervoltage release (D)

The undervoltage release can be combined with an electronic time-delay device for installing outside the circuit-breaker, which enables a delay in the tripping of the release with preset, adjustable times. The use of the delayed undervoltage release is recommended when the power supply network of the release can be subject to power cuts or short-lived voltage drops, in order to avoid trips.

When it is not supplied, circuit-breaker closing is prevented.

Model	B2342	B2410		Apparatus	Emax VF	Scale
				Doc. no.	1SDH000909R0001	Page No 28/66

The time-delay device has to be combined with an undervoltage release with the same voltage as the time-delay device. Reference figures in the electrical circuit diagrams: YU + D; (7).

The characteristics of the time-delay device are:

Power supply (D):	24-30 V AC/DC
	48 V AC/DC
	60 V AC/DC
	110-127 V AC/DC
	220-250 V AC/DC
Adjustable opening time (YU+D):	0,5-1-1,5-2-3 s

Geared motor for automatic closing spring loading (M)

This automatically loads the circuit-breaker operating mechanism closing springs. After circuit-breaker closing, the geared motor immediately sees to reloading the closing springs.

When there is no power supply or during maintenance work, the closing springs can still be loaded manually (by means of the special lever on the operating mechanism).

Power supply	24-30 V AC/DC
	48-60 V AC/DC
	100-130 V AC/DC
	220-250 V AC/DC
Operation limits:	85...110% Un (Norme CEI EN 60947-2)
Inrush power consumption (Ps):	DC = 500 W
	AC = 500 VA
Rated power (Pn):	DC = 200 W
	AC = 200 VA
Inrush time	0,2 s
Loading time:	4-5 s
Insulation voltage	2500 V 50 Hz (per 1 min.)

It is always supplied with limit contacts and microswitch for signalling closing springs loaded.

Reference figure in the electrical circuit diagrams: M (1)

Mechanical and electrical trip signalling for overcurrent releases

The following signals are available following tripping of the overcurrent release:

a) Mechanical trip signalling for overcurrent releases

This enables a visual signalling on the operating mechanism by pushing the trip pushbutton in when the circuit-breaker has been opened following tripping of an overcurrent release. The circuit-breaker can only be closed again by putting the pushbutton back into its normal position included in the standard configuration.

Reference figure in the electrical circuit diagrams: S51 (13).

b) Electrical and mechanical trip signalling for overcurrent releases

This enables a visual signalling on the operating mechanism (mechanical) and remotely (electrically by means of a changeover switch) of the circuit-breaker being opened following a trip of the overcurrent releases. To reset the circuit-breaker, it is necessary to reset the mechanical indicator pushbutton.

Reference figure in the electrical circuit diagrams: S51 (13).

c) Coil for resetting the mechanical release trip indicator

This enables a visual signalling on the operating mechanism (mechanical) and remotely (electrically by means of a changeover switch) of the circuit-breaker being opened following a trip of the overcurrent releases. With this accessory, you can reset the mechanical indicator with an electronic relay using a remote control and this enables the circuit-breaker to be reset.

Power supply:	24-30 V AC/DC
	220-240 V AC/DC
	110-130 V AC/DC

Reference figure in the electrical circuit diagrams: S51 (14)

Auxiliary contacts

Auxiliary contacts installed on the circuit-breaker are available to enable an indication of the circuit-breaker's status. A special version of the auxiliary contacts is also available (gold plated contacts) for a rated voltage under 24 V (digital signal).

Un	In max	T	Un	In max	cosφ
125 V DC	0,3 A	10 ms	250 V AC	5 A	0,3
250 V DC	0,15 A	10 ms			

Model	B2342	B2410		Apparatus	Emax VF	Scale
				Doc. No	1SDH000909R0001	Page No 29/66

The versions available are:

a) Electrical signalling for circuit-breaker open/closed

It is possible to have electrical signalling of the circuit-breaker status (open/closed) 4, 10 or 15 auxiliary contacts.

The auxiliary contacts can have the following configurations:

- 4 + 2 break/make contacts for PR122 (2 normally open + 2 normally closed + 2 for the release)
- 10 + 2 break/make contacts for PR122 (5 normally open + 5 normally closed + 2 for the release)
- 15 supplementary break/make contacts which can be mounted outside the circuit-breaker

The basic configuration described above can be modified by the user to indicate normally open or normally closed by repositioning the faston connector on the microswitch. When 10 contacts for PR122/ VF are required, the PR120/K module is not available.

Reference Fig. in the electrical circuit diagrams: Q/1÷10 (21-22)

b) Electrical signalling for circuit-breaker connected/test isolated/disconnected

In addition to mechanical signalling of the position of the circuit-breaker, it is possible to have electrical signalling by means of 5 or 10 auxiliary contacts which are installed on the fixed part.

Only available for circuit-breakers in withdrawable versions for installing on the fixed part.

The auxiliary contacts can have the following configurations:

- 5 contacts; group consisting of 2 connected signalling contacts, 2 disconnected signalling contacts and 1 test position signalling contact (main contacts isolated, but sliding contacts connected)
- 10 contacts; group consisting of 4 connected signalling contacts, 4 disconnected signalling contacts and 2 test position signalling contacts (main contacts isolated, but sliding contacts connected)

Reference figure in the electrical circuit diagrams: S75I (31-32) - S75T (31-32) - S75E (31-32)

c) Contact for signalling closing springs loaded

This consists of a microswitch which allows remote signalling of the state of the circuit-breaker operating mechanism closing springs. The contact is always supplied with the spring loading geared motor.

Reference figure in the electrical circuit diagrams: S33 M/2 - (11)

d) Contact for signalling undervoltage release energized (C.aux YU)

The undervoltage releases can be fitted with a contact (by choice, normally closed or open) for signalling undervoltage energized for remote signalling of the state of the undervoltage release.

Reference figure in the electrical circuit diagrams: (12)

Mechanical operations counter

This is connected to the operating mechanism by means of a simple lever mechanism. It indicates the number of circuit-breaker mechanical operations. The indication is visible on the front of the circuit-breaker from the outside.

10.2. Mechanical locks

a-b) Lock in open position

Different mechanisms are available which enable the circuit-breaker to be locked in the open position.

These devices can be controlled by:

- a key (a): a special circular lock with different keys (for a single circuit-breaker) or with the same keys (for several circuit-breakers). In the latter case, up to four different key code numbers are available.
- padlocks (b): up to 3 padlocks (not supplied): Ø 4 mm..

c) Circuit-breaker lock in connected - test isolated - disconnected position

This device can be controlled by a special circular lock with different keys (for a single circuit-breaker) or with the same keys (for several circuit-breakers available up to four different key code numbers) and by padlocks (up to 3 padlocks, not supplied - Ø 4 mm). Only available for circuit-breakers in withdrawable versions for installing on the moving part.

d) Accessories for lock in test isolated - disconnected position

In addition to the circuit-breaker lock in the connected - test isolated - disconnected position, this allows locking only in the disconnected or test isolated positions. Only available for circuit-breakers in withdrawable versions for installing on the moving part.

e) Accessories for shutter padlocks

They enable the shutters to be padlocked (installed on the fixed part) in the closed position.

Only available for circuit-breakers in withdrawable versions for installing on the fixed part.

f) Mechanical lock on compartment door

This prevents the compartment door from being opened when the circuit-breaker is closed (and connected in the case of withdrawable circuit-breakers) and prevents circuit-breaker closing with the compartment door open.

Transparent protection covers

a) Protection covers for opening and closing pushbuttons

These protection covers, applied over the opening and closing pushbuttons, prevent the corresponding circuit-breaker operations except by using a special tool.

b) IP54 door protection

This is provided by means of a transparent plastic escutcheon plate which fully protects the front of the circuit-breaker and ensures a degree of protection to IP54. Mounted on hinges, it is fitted with a key lock.

Interlock between circuit-breakers

This mechanism makes the mechanical interlock between two or three circuit-breakers (even of different sizes and in any fixed/withdrawable version) by means of a flexible cable. The electrical circuit diagram for the electrical changeover by means of a relay (to be provided by the customer) is supplied with the mechanical interlock. The circuit-breakers can be installed vertically or horizontally. 4 types of interlocks are available:

type A: between 2 circuit-breakers (power supply + emergency)

Model	B2342	B2410		Apparatus	Emax VF	Scale
				Doc. no.	1SDH000909R0001	Page No 30/66

type B: between 3 circuit-breakers (2 power supplies + emergency)

type C: between 3 circuit-breakers (2 power supplies + bus-tie)

type D: between 3 circuit-breakers (3 power supplies / a single closed circuit-breaker)

The emergency power supply is generally supplied in order to substitute the normal power supply in two cases:

- to supply safety services for people.
- to supply essential parts of the installation for other than the safety services.

The change over from the normal supply to the emergency supply, can be done manually (with a local or remote control) or automatically. For the change over, the circuit-breakers must be supplied with the necessary accessories for the electrical remote control and for electrical and mechanical interlocks provided for the changing over.

The accessories can be for example:

- the shunt opening release
- the shunt closing release
- the motor operator
- the auxiliary contacts

For the change over, the customer can use a suitable electronic relay, whose diagram is supplied by ABB SACE. The mechanical interlocks between two or three circuit-breakers are made by means of cables that can be used for circuit-breakers installed, either side-by-side or one over the other.

Table of feasible mechanical interlocks between two or three circuit-breakers

Type of interlock	Number of circuit-breakers	Type of circuit-breaker	Possible interlocks
A	TWO	A normal power supply unit and an emergency unit.	The first circuit-breaker can be closed only if the second (emergency) breaker is open.
B	THREE	Two normal power supply units and an emergency unit.	The first and third circuit-breakers can be closed only if the second (emergency) breaker is open. The latter can be closed only if the first and third are open.
C	THREE	A unit of 2 supplies and a bus-tie. The two half-busbars can be supplied by a single transformer (bus-tie closed) or simultaneously by both (bus-tie open).	One or two circuit-breakers out of three can be closed at the same time.
D	THREE	A unit of 3 supplies / a single closed circuit-breaker. Three supplies (generators or transformers) on the same busbar for which parallel operation is not allowed.	Only one of the three circuit-breakers can be closed.

10.3. Notes for Emax LTT Low Temperature accessories

The SACE Emax VF LTT, switch disconnecter designed for low temperature environment, is accessible only with the standard opening, closing and undervoltage releases at 220V AC/DC.

The geared motor for the automatic charging of the spring is available with a special version for low temperature at 220V AC/DC.

Auxiliary contacts, terminals and fixed parts are in common to the Emax VF product.

Transparent pushbuttons protection covers, IP54 door protection, interlocks, homopolar toroid, time delay device for undervoltage release and external neutral current sensors are not available.

10.4. Spare parts and retrofitting

Spare parts

The spare parts available are:

- Arcing chamber
- Stored energy operating mechanism (*) (Type "A")
- Closing springs kit (*) (Type "A")
- Contact kits for clamp disconnection for a fixed part of the removable circuit breaker
- Creeping earth contacts (for withdrawable version)
- Frontal shield kit complete with caps and side shields
- Safety shutters fixed part shutters
- Transparent protection for PR122/VF release
- Opening solenoid for maximum current release PR122/VF
- Testing front connecting cap for relay
- SACE PR030/B power supply unit
- Lubricating grease for stored energy operating mechanism
- Terminal board for fixed
- Creeping contacts, fixed part
- Creeping contacts, movable part
- Dust tab for door of cell
- Extraction crank
- Lifting plates pair
- Front escutcheon plate for Ronis-type key lock

For further details, ask for the ABB SACE spare parts catalogue.

(*) Subject to the customer's approval, ABB can replace "A" type parts.

Model	B2342	B2410		Apparatus	Emax VF	Scale
				Doc. No	1SDH000909R0001	Page No 31/66

11. Protection releases - General notes

The Emax air circuit-breakers serie is now improved with the PR122/VF, a new variable frequency electronic relay, .

A table can best illustrate the technical features of the relay.

Function/Unit		PR122/VF	
Current protections (L, I)		S	
Temperature protection (OT)		S	
Wire communication (RS485)		S ⁽¹⁾	
Data Logger		S	
Compatibility with Ekip Connect		S	
PR120/K Signalling (internal signalling module)		O	
PR120/D-M Com (internal communication module)		O	
PR120/DC (Key plug module)		S	
PR030/B (separate power supply unit)		S	
BT030-USB (separate Bluetooth communication unit)		O	

Key:

S : standard function/unit,

O : optional function/unit.

Notes:

1. : with PR120/D-M module.

Safety notes

 **WARNING: this symbol gives information about operations, actions or circumstances that can cause injuries to the personnel, damage to the unit or economic losses.**

Read this manual carefully and completely.

The use of this device should be reserved for qualified and expert personnel only.

If in doubt about its safe usage, the unit must be put out of service to prevent any accidental use.

You must assume that safe usage is impossible if:

1. the unit shows visible signs of damage.
2. the unit does not function (for example with autotest or with the trip test unit).
3. the unit has been damaged in transit.



WARNING: Before putting into service it and/or replacing, the circuit-breaker must be open. Also remember to disconnect all power supplies connected.

11.1. Notes for dielectric stiffness tests



WARNING: Dielectric stiffness tests must not be performed on releases, inputs or outputs. To perform impulse insulation tests (e.g. 8 Kv) on the main circuits of an Emax VF circuit-breaker, first disconnect the PR122/VF-specific connectors XK10, XK11 and XK12, by removing the actual relay as indicated in figure 21 on page 12 of this manual. It is obligatory to have re-assembled the front protection release before performing the test. Once the test has terminated, re-assemble the relay with all its connections, check that the connecting screws of the cables of the terminal boards are tight (0.7 Nm), then proceed with a test cycle as described in sections 8.3.1, 8.3.7 and 8.3.9. Please consult ABB if further details are required.

Model	B2342	B2410		Apparatus	Emax VF	Scale
				Doc. no.	1SDH000909R0001	Page No 32/66

11.2. Abbreviations and notes

11.2.1. Abbreviations

Abbreviations	Meaning
YO	Opening coil
YC	Closing coil
BT030-USB	Power supply and bluetooth communication unit, ABB SACE - USB
CB	Circuit-Breaker (for example Emax)
Emax	Series of ABB SACE air circuit-breakers
HW	Hardware
In	Rated current of the Rating Plug installed in the circuit-breaker
PR120/K	Internal signalling unit of alarms and trips of the circuit-breaker
PR120/D-M	Communication module
PR120/DC	Key plug module
PR122/VF	Protection relay for CB Emax
PR030/B	ABB SACE power supply unit
Relay	also called "protection unit" or "protection release"
TC	Trip Coil (opening solenoid)
SW	Software
i-Test	"i-Test" button on the front of relay
Trip	CB opening, generated by the release
Vaux	Auxiliary power supply

11.2.2. Notes

- A. Use the "Belden 3105A"- type two-wire cable for instance (not supplied by ABB SACE).
- B. Use the "Belden 3106A"- type three-wire cable for instance (not supplied by ABB SACE).
- C. The unit has a "backup-protection" function; if the first command to the opening solenoid does not open immediately the circuit-breaker (TC partially fault), TRIP commands are repeatedly sent until the circuit-breaker opens (providing a Vaux is present) or the current disappears (if self-power supplied). The "backup" condition can be signalled by configuring the unit relays; using the "YO back" selection, it is possible to command the "opening coil(YO)" accessory as another opening device if TC does not work.

Model	B2342	B2410		Apparatus	Emax VF	Scale
				Doc. No	1SDH000909R0001	Page No 33/66

12. SACE PR122/VF Release - Identification

The configurations available for PR122/VF including standard protection functions as well as optional modules, are illustrated in the following figure:

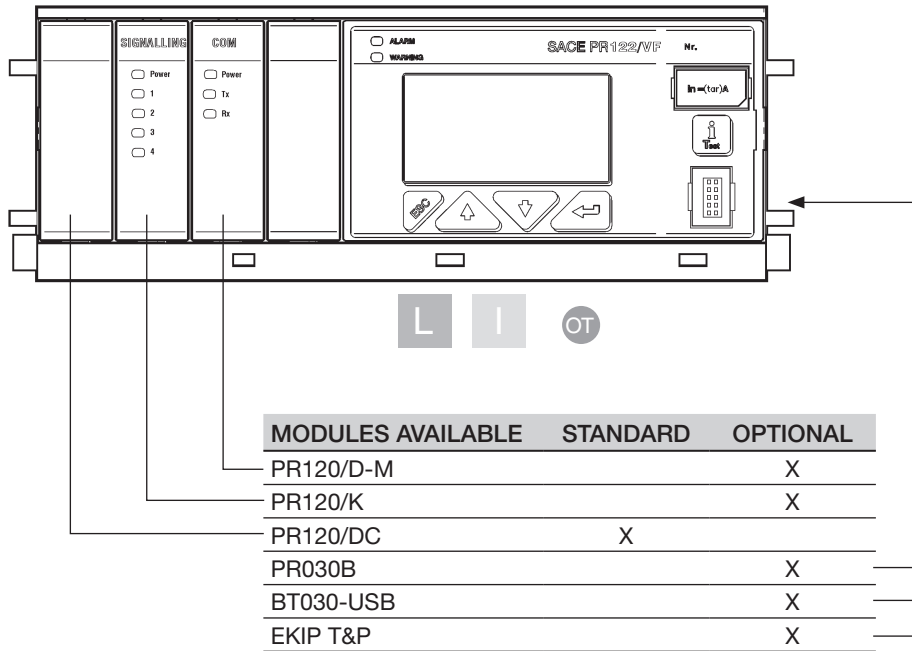

12.1. General

12.1.1. Main Features

The PR122/VF is a high-performance protection unit offering **Protection, Measurement, Data storage, Communication (optional), Self-test and Load control** functions for ABB SACE 'Emax' low-voltage air circuit-breakers, for application at variable frequency.

The PR122/VF unit installed on CB is connected to current sensor resistor for reading of primary current signals, and to Trip Coil for the management of CB Opening commands.

Depending on the protections settings, the unit manages timing and commands to open CB.

All the settings and protection setups are accessible to user through a menu on the display, or by using external communication software. The protections available for the PR122/VF are:

Symbol	Protection type
L	Overload with inverse long time delay
I	Instantaneous short-circuit
OT	Temperature out of range

By connecting Accessory units, it is possible to expand the performance information management, signals and commands:

- with module PR120/D-M it is possible to start remote communication with the unit and to command mechanical accessories as Yo and YC.
- with module PR120/K it is possible to use external contacts associated to the CB events or status.
- with external unit BT030-USB or Ekip T&P it's possible to start temporary communication for settings, test, and information collection.

The unit must be supplied by Auxiliary external voltage (AUX) in order to work.

12.1.2. Standard Reference

The PR122/VF has been designed to work in accordance with the international standard:

IEC 60947-2 Low voltage apparatus. Circuit-breakers.

12.1.3. Operation condition

For correct operation of the unit, the following conditions must be fulfilled:

12.1.3.1. Environmental condition

The PR122/VF unit is provided with an internal temperature check sensor: in case of temperature out of range, a warning/alarm condition will be shown on the display and signaled by LEDs

Operating temperature	-25°C... +70°C
Storage temperature	-40°C ... +90°C
Relative humidity	0% ... 98% with condensation
Degree of protection (with PR122/VF installed in the CB)	IP 30

Model	B2342	B2410		Apparatus	Emax VF	Scale
				Doc. no.	1SDH000909R0001	Page No 34/66

12.1.3.2. Power Supply specifications

Unit PR122/VF checks the presence of the auxiliary power supply (AUX); in case of AUX not being present and with the unit supplied by external module as BT030-USB, an alarm condition is shown:

Auxiliary voltage	24V DC \pm 20%
Maximum ripple	5%
Inrush current	\sim 10 A for 5ms (max)
Rated power (without module PR120/D-M and PR120/K)	\sim 3W (max)
Rated power (with module PR120/D-M and PR120/K)	\sim 5W (max)



WARNING: The external auxiliary power supply (AUX) must be always provided to the trip unit: without AUX, the trip unit does not work, and the CB is not protected.

It is recommended to use a backup battery to guarantee the presence of the AUX, or to add to the circuit breaker an undervoltage release (YU) to open the CB if AUX is not present.

The AUX must be supplied by using a galvanically-separated power pack:



WARNING: Since the auxiliary voltage needs to be isolated from the ground, “galvanically separated converters” must be used, in accordance with the IEC standard 60950 (UL 1950) or the equivalent IEC 60364-41 and CEI 64-8, to guarantee a current in common mode or leakage current (as defined in IEC 478/1 and CEI 22/3) no greater than 3.5mA.

The Connection of AUX must be made with a two-pole shielded twisted cable (example: BELDEN 3105A/3105B).



WARNING: The unit PR122/VF display backlight will be ON only with AUX within required range.

12.2. User Interface

The settings and information regarding PR122/VF are accessible to the user via the local display. The user can access the menu by using the push buttons on the front of the unit.

Settings and information are also available using external module that allows remote communication.

Ref.	Description
1	LED indicators
2	Graphic Display
3	Serial Number
4	Rating Plug
5	Position for PR120/K module
6	Position for PR120/D-M module
7	Main Push-buttons
8	iTest push Button
9	Test connector for external unit

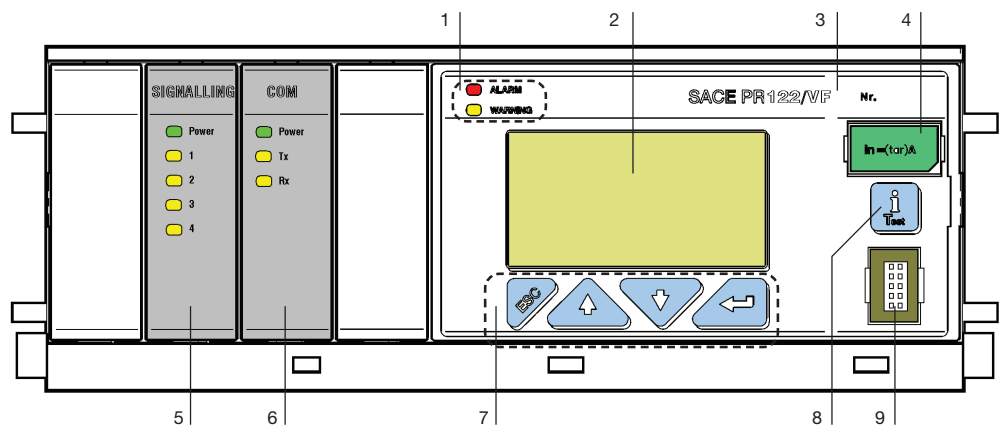

The following is a description of the main characteristics of the user interface. The optional and external modules are described starting from para.12.4.

12.2.1. LEDs

There are 2 LEDs on the front of the PR122/VF: both LEDs function only with the trip unit turned on, and offer the user simple evidence of the status of the trip unit and CB.

In the table that follows, descriptions of the main LEDs are related to trip unit turned ON:

LED	Color	Condition	Description
ALARM	Red	OFF	NO Protection ALARM or Timing
		ON (Blink @1Hz)	Protection L Timing Alarm on one or more of: Contact Wear, Temperature Error on one or more of: Rating Plug, Key Plug, Trip Coil
		ON (Fixed)	Internal Error (necessary assistance of ABB)
WARNING	Yellow	OFF	No Alarm or CB Error
		ON (Blink @0.5Hz)	Temperature Pre-Alarm
		ON (Blink @1Hz)	Temperature Alarm
		ON (Fixed)	AUX absent Prealarm on one or more of: L protection, Contact Wear Error in one or more of: Configuration, CB status, Harmonic distortion IW warning

Model	B2342	B2410	Apparatus	Emax VF	Scale
			Doc. No	1SDH000909R0001	Page No 35/66

12.2.2. Display

During the normal working conditions the display shows all the most important information regarding the trip unit and CB on a default page:

Entering the menu, all the options are shown as follow.

Ref.	Description
1	Graphic Ammeters
2	Cb and Trip unit Error (if there are no errors the ABB logo is displayed)
3	Trip unit clock
4	Ammeter value, and phase of the higher current reading
5	Working Icon
6	Name of menu in use
7	Number of options in the menu in use
8	List of Options available (the option selected is indicated)
9	Value or description of the Option selected

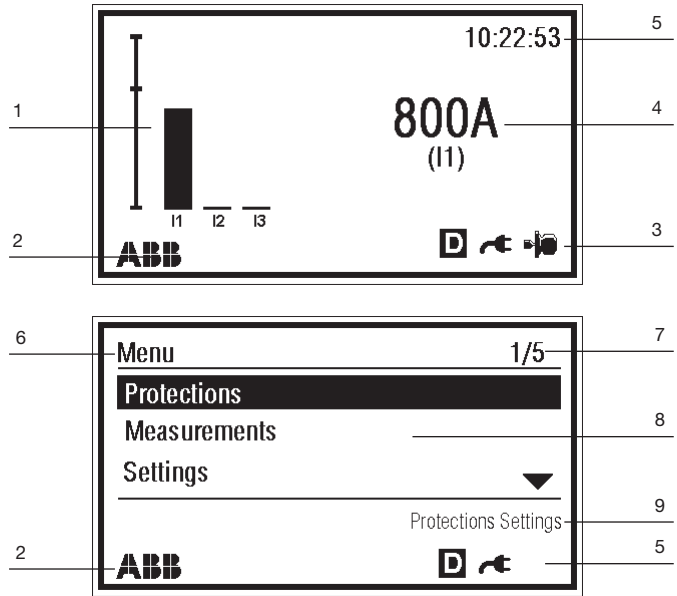

Menu description for the management of settings and parameters, available at para.12.3.3.

12.2.2.1. Ammeters on Display

The display shows the graphic Ammeter, and the reading of the runtime measurement of the currents value. The graphic shows the level of the currents related to each phase. The CB nominal current level is shown on the vertical bar

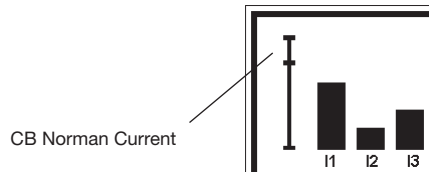

The default page also shows the value of the higher current measured runtime of the 3 phases; below the value, is available also the phase of the maximum current shown.

From the default page, by pushing the DOWN or UP button, it is possible to access to the CURRENT MEASUREMENTS page, with the measurement. of all 3 phase currents.

12.2.2.2. CB and Trip Unit Error

The error messages regarding the trip unit and CB are shown on the bottom-left corner of the display. Every message, except for the ABB logo, is shown with an ICON representing the warning level





ICON	Message	Description
!	Configuration	Parameters inconsistency
	L Prealarm	Protection L prealarm
	T prealarm	Protection T prealarm
	Warning IW	IW threshold exceeded
	Contact Wear	Contact Wear Prealarm (80% ≤ CW ≤ 99%)
	Invalid date	Clock information Lost. Necessary to reset new date
	Required	Absence of AUX
	CB Undefined	CB status inconsistent
⚠	Timing L	Timing protection L
	T Alarm	Alarm for protection T (out of range)
⚠	Contact Wear	Contact Wear Alarm (CW= 100%)
	T (trip OFF)	Alarm for protection T
	LC1 Load or LC2 Load	Alarm for load control LC1 (or LC2)
	TC Disconnected	Trip Coil absent or faulty
	Rating plug	Rating plug absent or faulty
	Installation	Key plug absent or faulty

All the detected errors will be shown one at a time, with frequency 0.5Hz. If there are no errors present, the ABB logo is displayed.

Model	B2342	B2410		Apparatus	Emax VF	Scale
				Doc. no.	1SDH000909R0001	Page No 36/66





12.2.2.3. Working ICON

In the bottom-right corner of the display, the user can find icons that give information about the working condition of the trip unit.

ICON	Condition	Description
	ON	Updating on run. This ICON appears when a parameter or a setting has just been changed, and the operation of updating must be completed with CONFIRMATION by the user
	OFF	No updating in progress
	ON	AUX present
	OFF	AUX absent
	ON (fixed)	DATALOGGER function ON and waiting for a recording event
	ON (flash @1Hz)	DATALOGGER function ON, recording completed, and waiting for download
	OFF	DATALOGGER function OFF
	ON (position of screw)	Remote mode (parameters and settings can be changed only by remote; function available only with unit PR120/D-M installed)
	OFF	Local mode (user can change parameters and settings)

12.2.3. Push Button

To enter the user menu and change parameters and settings, the user can use a 4 push-button keyboard. A “Test” push button is also available for different functions.

Button	Name	Description
	iTest	With display on Default page, by pushing the iTest button 3 information pages are available: protection unit information, Circuit Breaker information, Last trip information After a trip, allow the trip page displayed to reset, and to return to the default page With unit turned OFF, by pushing the iTest Button within 48hours, it is possible to read the last event that lead to shutting OFF
	ESC	With display on Default page, by pushing the ESC button it is possible to enter in the main menu Into menu, allow return to the previous level Aborting change
	ENTER	Into the main menu, allow choice of the items Confirm change
	UP	With display on Default page, by pushing UP or DOWN buttons it is possible to enter in the Current Ammeter page
	DOWN	Move into the menu Change parameters and settings values.



WARNING: For some parameters with a large range, it is possible to hold the button down (UP or DOWN), to speed up the modification of the value.

12.2.4. Rating plug

The rating plug is a module used by trip unit to identify the rated current (In) of the CB.
On PR122/VF unit, the removal or exchange of the Rating plug module is not permitted.

12.2.5. Optional Module

The PR122/VF unit can be connected to two optional module, each in their dedicated socket.
Both units must be connected with trip unit turned OFF.
Details of the module performances are available starting from para.12.4.

12.2.6. External Module

The PR122/VF unit can be connected to external temporary module:

- The PR030/B unit is a battery unit useful to supply the PR122/VF unit, and for Trip test from display.
 - Units BT030-USB and Ekip T&P allow the user to supply and communicate with PR122/VF, using ABB Software Ekip Connect.
- More details starting from para.12.4.

12.3. User Menu

On the PR122/VF unit display, the user can access to 2 different sectors: the Main Area, and the Menu area.
The Main Area is composed of the default page, the CURRENT MEASUREMENTS page, and the information page.
The pages are available using the iTest Button.

The menu area contains all the sections useful for reading and setting of all protection and parameters, testing of the unit, and installation.



WARNING: With the exception of the CURRENT MEASUREMENTS page, the unit will display the Default page if no buttons are pressed for 2 minutes.
To access to some areas it is necessary to enter a password (PW); default value of PW: 0001.

Model	B2342	B2410		Apparatus	Emax VF	Scale
				Doc. No	1SDH000909R0001	Page No 37/66

12.3.1. Main Area

Starting from default page:

Button	Action	Return to default page
UP/ DOWN	CURRENT MEASUREMENTS PAGE	Button UP/DOWN
iTest	(x1) Protection unit Info; (x2) Circuit Breakers info; (x3) Last Trip Info	Button ESC

12.3.2. Menu Area

The Menu Area has a tree structure that allows the management of the settings and information at various levels.

In the Menu area it is possible to move using the UP, DOWN, ENTER, ESC buttons:

- UP and DOWN for selection of the required option/level/value.
- ENTER button to confirm the selection, to enter the next menu level, to confirm the value changed.
- ESC button to abort the selection, to return to the previous level of menu, to abort the value change.

Level 1	Description	Level 2	Description
1. Protections	Protection settings	1.1. L Protections	Set parameters
		1.2. I Protections	Enable/disable, and set parameters
		1.3. T Protections	Enable/disable Trip
		1.4. LC Protections	Set parameters 1, 2, Iw
2. Measure-ments	Reading of Current Measurements, Trip and Events history	2.1. Historical	Read Trips, Events Log, Measurements
		2.2. Contact Wear	Read value
3. Settings	Managing of trip unit settings, CB settings, Optional functions, Module parameters	3.1. Circuit Breaker	Set Frequency, Unit Installation
		3.2. HW trip	Enable/disable function
		3.3. Modules	Set parameters
		3.4. Data logger	Enable/disable, and set parameters
		3.5. Measure store time	Set value
		3.6. System	Set Date, Hours, Language, Password
		3.7. Display Contrast	Set value
4. Test	Check of CB status, test of Trip Coil and display	4.1 CB Status	Read CB Status
		4.2 Auto test	Perform Display and LEDs test
		4.3 Trip Test	Perform Trip Coil test
		4.4 COM module	Read CB Status and test Module
		4.5 SIGNALLING module	Test Module
5. About	Trip unit information, CB information	5.1 Protection unit	Read trip unit info
		5.2 Circuit Breaker	Read CB info

The following is a description of the mains 2 level in the Menu area.

12.3.2.1. Changing of parameters

In the Menu Area it is possible to modify all the parameters.

To access to change parameters area, it is necessary to use the PW.

 **WARNING: To change some parameters only the access PW is required (example: DATE change); Some parameters need the PW to gain access, and also the confirmation by the user: a special box will appear where it is possible to enter CONFIRM (to finish updating), ABORT (to delete updating) or MODIFY (for parameter modification).**

12.3.3. Protections

The following is a description of all the protection available to the user in the Protections area:

- Protection against Overload (L protection).
- Protection from instantaneous short-circuit (I Protection).
- Self-protection against over-temperature (T protection).
- Load Control function LC1, LC2, Iw (Load Protection).

The PR122/VF unit manages 4 states depending on main protections threshold (I_1 , I_3 if ON), and level of primary current (I_t):

No Alarm: $I_t < 0.9 I_1$	The CB remains close.
L Prealarm: $0.9 I_1 < I_t < (1.05...1.3) I_1$	The CB remains close.
L Alarm: $(1.05...1.3) I_1 < I_t < I_3$	The CB will open for L protection.
I Alarm: $I_t > I_3$	The CB will open for I protection.

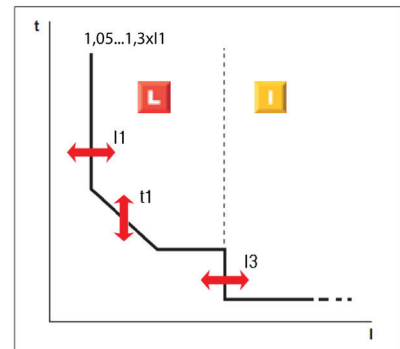

Model	B2342	B2410		Apparatus	Emax VF	Scale
				Doc. no.	1SDH000909R0001	Page No 38/66

12.3.3.1. L Protection

The L protection cannot be disabled.

On unit PR122/VF it is possible to select current threshold (I_1) and time (t_1), and to define the preferred tripping time (t_{trip}).

Setting	Range Value	Description
Threshold I_1	0.4In...1In (step 0.01In)	Set fault threshold of the primary current
Time t_1	3s...102s (step 3s)	Set t_{trip} of L protection

The unit applies an inversion time expression to calculate t_{trip} .

The expression considers the primary fault current (I_f), and the protection parameters (I_1 and t_1):

Condition	t_{trip} (s)	Example
$I_f \leq 10I_n$	$\left(\frac{t_1}{0,1178}\right) \times \ln\left(\frac{(I_f)^2}{(I_f)^2 - (I_1)^2}\right)$	$I_1 = 0.8 \times I_n; t_1 = 12s$ $I_f = 1.5 \times I_1 (1.2 \times I_n)$ $t_{trip} = \left(\frac{12}{0,1178}\right) \times \ln\left(\frac{(1,2)^2}{(1,2)^2 - (0,8)^2}\right) = 101,87 \times 0,588 = 60s$
$I_f > 10I_n$	0.5	$I_1 = 0.8 \times I_n; t_1 = 12s$ $I_f = 15 \times I_1 (12 \times I_n)$ $t_{trip} = 0.5 s$



WARNING: L Threshold has activated in the range 1.05...1.2 of the setting. The minimum trip time is 0.5s. See trip curves for further details.

12.3.3.2. I Protection

The I protection is enabled/disabled on protection menu.

On unit PR122/VF it is possible to select current threshold (I_3), and there is the possibility to set Start-up parameters.

Setting	Range Value	Description
Enable	ENABLE/DISABLE	Determines the presence or absence of the protection.
Threshold I_3	1.5In...10In (step 0.1In)	Determines the fault threshold of the primary current
Startup Enable	ENABLE/DISABLE	Determines the presence/absence of the Start-up function.
Startup threshold	1.5In...10In (step 0.1In)	Determines the start-up current threshold
Startup time	0.1s...30s (step 0.01s)	Determines the activation duration of the start-up threshold

While the I protection is turned OFF, only the L protection will operate for all the fault current range.

While the I protection is turned ON, the unit will trip by I protection with $I_f > I_3$. The t_{trip} for I protection is $\leq 60ms$.

The Start-up function is enabled/disabled from the I protection menu. The Start-up function enables the protection threshold I_3 to be changed during a t_s time interval, starting from the passing of almost 1 of the phase currents over the "Start-up activation threshold".

The "Start-up activation threshold" is an adjustable parameter for values within the range 0.1...10In, with steps of 0.1In.

The parameter is available only by external communication, using the module PR120/D-M, or the external unit BT030-USB or Ekip T&P with ABB Software Ekip Connect.

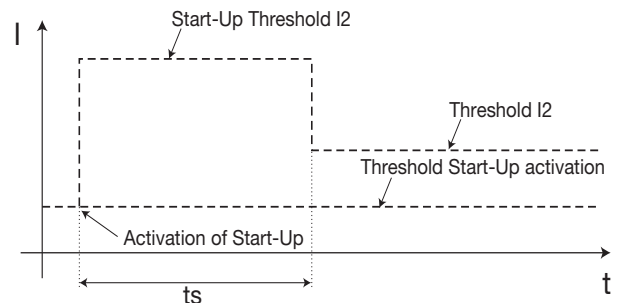

A new start is possible after the current has dropped below this threshold.



WARNING: On the display menu, the I protection settings (threshold and Startup parameters) are available to user only with protection enabled. About Startup function, all settings (threshold and time) are available to user only with function enabled.

12.3.3.3. T Protection

Inside unit PR122/VF, there is a temperature sensor that monitors the temperature of the unit.

The sensor enables the signalling of any abnormal temperature conditions, which could cause temporary or continuous malfunctions of the unit or the electronic components.

On unit PR122/VF it is possible to Enable the Trip in case of T alarm.

Setting	Range Value	Description
Trip Enable	ENABLE/DISABLE	Set the possibility of CB Opening in the case of T alarm

Model	B2342	B2410	Apparatus	Emax VF	Scale
			Doc. No	1SDH000909R0001	Page No 39/66

For temperature, the unit has 3 states of operation:

Temperature (temp)	State	Description
-20° < temp < 70°	Normal	No signalling on display and LEDs. All features activated.
-25° < temp < -20° or 70° < temp < 85°	Warning Temperature	Display turned OFF. Protections activated. Warning LED ON (Blink @0.5Hz)
temp < -25° or temp > 85°	Alarm Temperature	Display turned OFF. Protections activated. Warning and ALARM LED ON (Blink @1Hz) In case of Trip Enable= ENABLE, the CB will istantaneously open.

The temperature value is not available on display.

 **WARNING: In Warning and Alarm states, the dispaly is turned OFF to preserve its functionality. In case of Trip enable= DISABLE, the PR122/VF unit could work, with CB closed, in a range of temperatures within which the correct operation of the trip unit is not guaranteed.**

12.3.3.4. Load Protection

The Load Protection consists of LCs and lw functions. The functions can be enabled/disabled on protection menu. Single loads can be disconnected on the load side before the overload protection L opens the CB. This is done by contactors or switch-disconnectors (wired outside the release), controlled by the PR122/VF and PR120/K external contacts.

On unit PR122/VF it is possible to select presence of LCs or lw function, and to set thresholds.

Setting	Range Value	Description
Threshold 1	ENABLE/DISABLE	Determines the presence or absence of the load LC1 threshold.
↳ Threshold	50% I1...100% I1 (step 1%)	Determines the threshold for LC1 Alarm
Threshold 2	ENABLE/DISABLE	Determines the presence or absence of the load LC1 threshold.
↳ Threshold	50% I1...100% I1 (step 1%)	Determines the threshold for LC1 Alarm
Threshold lw	ENABLE/DISABLE	Determines the presence or absence of the lw threshold.
↳ Threshold	0.3In...10In (step 0.05In)	Determines the threshold for lw warning

Thresholds LC1 and LC2 are expressed as a percentage of I₁. lw threshold is expressed as an absolute value.

 **WARNING: The LCs Alarm and lw warning do not cause the CB to open by trip Coil, but the change of status of the SW register does. It is possible to have external monitoring, using PR120/K unit and setting external contacts to LC1, LC2, lw status.**

12.3.3.5. Trip performances and activation time

The following is a summary of Trip performance and tolerance, for all protections.

Protections	Threshold		Time Setting	Trip	
	Setting	Tolerance		Time	Tolerance
L	0.4In...1In	Activation into range 1.05...1.3 of I1	3s...102s	min: 0.5s. max: depends by expression	± 20%
I	1.5In...10In	± 20%	Fixed by unit	≤ 60ms	--
OT	Fixed by unit: temp < -25° or temp > 85°	± 5°	Fixed by unit	≤ 60ms	--

 **WARNING: All tolerance refer to a primary signal with frequency within the range 0.2...1.25 of the nominal frequency. Parameters I3 Startup threshold and time are not reported on the table: they do not influence Trip timing, but only the usage interval of another threshold**

For others functions:

Protections	Threshold		Time Setting
	Setting	Tolerance	
LC1, LC2	50% I1...100% I1	± 10%	Fixed by ABB:
lw	0.3In...10In	± 10%	Activation whitin range 10ms...40ms

Model	B2342	B2410		Apparatus	Emax VF	Scale
				Doc. no.	1SDH000909R0001	Page No 40/66

12.3.3.6. Curves

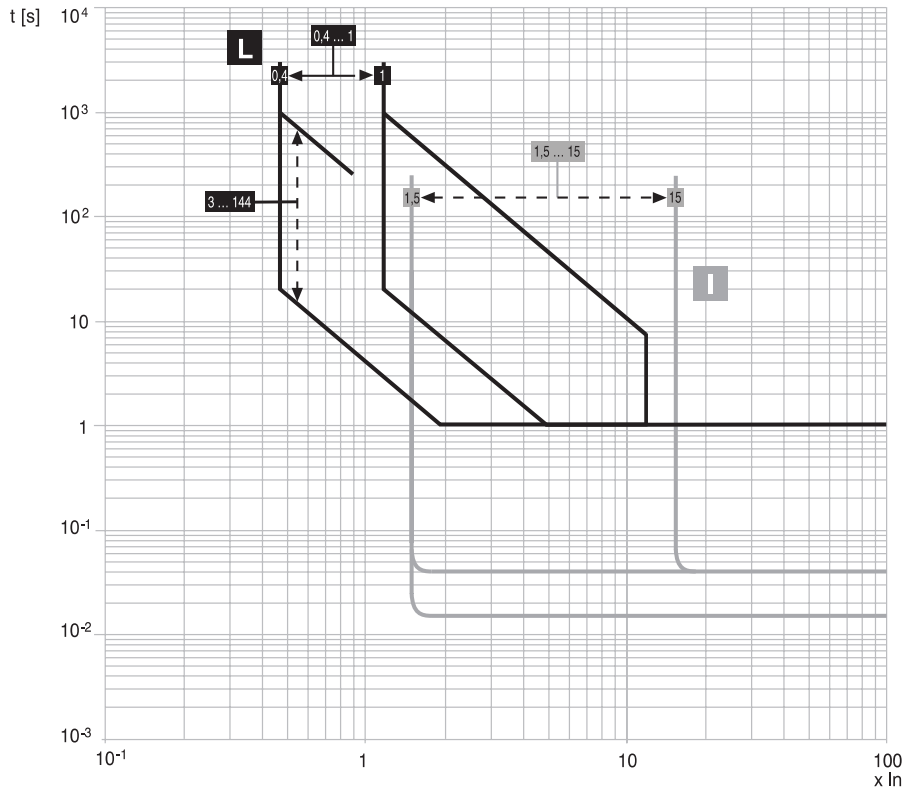

12.3.4. Measurements

The following is a description of all the measurements available to the user into the Protections area:

- Details of last 20 CB protection openings (Trip).
- Details of last 80 logged events (Events).
- Graphic ammeter of last 25 storage measurements (Measurements I_{max})
- Contact Wear of CB (Contact Wear).

12.3.4.1. Trip

The display shows information about trips as follows:

Ref.	Description
1	Trip number (the highest number is the last trip)
2	Date and time of trip
3	Protection that caused trip
4	Current value during trip

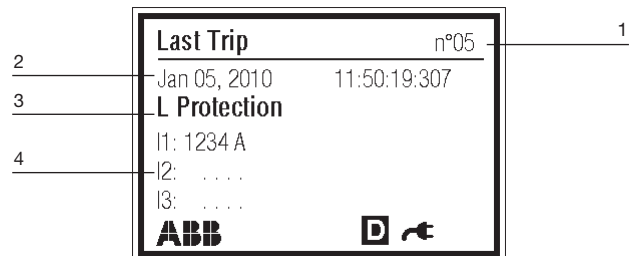

By choosing Trip from the Historical menu, the last one recorded will be shown. To view the other trip details, use the UP and DOWN push buttons.

12.3.4.2. Events

The display shows information about Log events as follows:

Ref.	Description
1	Log number (the oldest Log is shown with "Last-79")
2	Date and time of Event
3	Description of the event, and Icon related to the warning level of the event

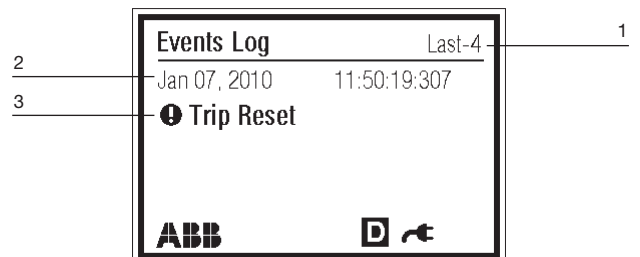

By choosing Events from the Historical menu, the last one recorded will be shown. To view the other trip details, use the UP and DOWN push buttons.

Model	B2342	B2410		Apparatus	Emax VF	Scale
				Doc. No	1SDH000909R0001	Page No 41/66

12.3.4.3. Measurements

On the Historical menu it is possible to select the measurements section.

In this area it is also possible to view at the last 25 storage measurements (Imax) or to reset the measurements (Reset Measurements). The display it will show information about storage measurements as follows:

Ref.	Description
1	Type of Measurement
2	Date and Time of the storage measurement selected
3	Imax of the storage measurement selected
4	Measurement storage time
5	Graphic ammeter of last 25 measurements (the Selected Measurement will blink)

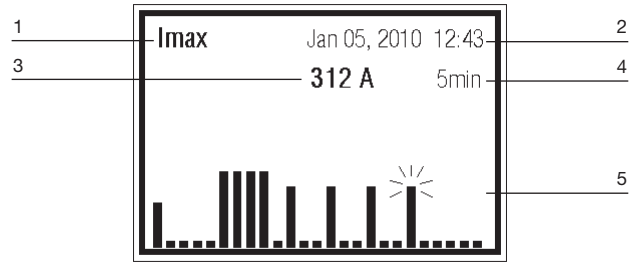

To scroll all the measurement data, use the UP and DOWN push buttons. The blinking Graphic helps to identify the timing of storage (the last measurements recorded is the first one on the right).

With the reset measurements command, the Imax section will be empty, and no information can be scrolled.

The following are the measurement performances.

Type of measurement	Range of measurements available	Precision on standard operation range
Current	$I > 0.1 I_n$	$\pm 5\%$ (on range $0.5 I_n \dots 1.2 I_n$)



WARNING: The measurement precision refers to the admitted working range of frequency. See para.12.3.5.1 for table of settings available to user.

12.3.4.4. Contact Wear

On the Measurements menu it is possible to read the Contact Wear percentage, indicating the percentage of wear on the CB contacts. This is just an approximate estimation of the real value of contacts wear.

12.3.5. Settings

The following is the description of all the parameters and setting available to the user into the Settings area:

- CB Installation and CB nominal frequency (Circuit Breaker).
- Set of HW trip function.
- Optional Module PR120/D-M and PR120/K configuration (Modules).
- Data logger function configuration (Data logger).
- Set Measurement store time.
- Set system settings such as Language, Date, time, new password (System).
- Set Display Contrast.

12.3.5.1. Circuit Breaker

In this section it is possible to set the CB frequency, and is possible to access the section for CB installation.

Are available 4 different nominal frequency values:

Nominal frequency	Working range
6.6 Hz	1 Hz...8 Hz
16.6 Hz	3 Hz...20 Hz
25 Hz	5 Hz...30 Hz
50 Hz	10 Hz...60 Hz



WARNING: On PR122/VF the frequency measurement is not available. All the trip tolerances detailed in para.12.3.3.5, and measurement tolerances detailed in para. 12.3.4.3, refer to the guaranty that the nominal frequency is within the working range $0.2 \dots 1.25$ of value set.



WARNING: The CB installation operation is not available to the user, only to ABB personnel.

12.3.5.2. HW trip

In this section it is possible to activate/deactivate the HW trip function.

If activated, and in the event of:

- CB undefined
- Rating Plug error
- Installation error

a CB opening command will be given by the TC.

Model	B2342	B2410		Apparatus	Emax VF	Scale
				Doc. no.	1SDH000909R0001	Page No 42/66

12.3.5.3. Modules

In this section it is possible to set the Module parameters.

All parameters are available only with unit present. COM module refers to PR120/D-M (Communication module); SIGNALLING module refers to PR120/K (Signalling module).

Module	Setting	Range	Description
COM module	Local/Remote	Local / Remote	The change of parameters setting by user is available on display menu, or using external communication.
	Serial Address	1...247 (step 1)	Set the address
	Baud rate	9600 bit/s / 19200 bit/s	Set the Baud rate
	Physical protocol	8,E,1 / 8,O,1 / 8,N,2 / 8,N,1	Set the kind of byte for communication (N°bit, Parity, stop bit).
	Addressing	Modbus standard / ABB	Set the address for communication.
SIGNALLING module	Relay n.1	- Signal Source: list - Delay: 0.01s...100s (step 0.01s) - Status: NO / NC - Latched: ON / OFF	- Allow selection of events to associate with each contact.
	Relay n.2		- Set the changing status delay of contact.
	Relay n.3		- Set the normal status of the contact.
	Relay n.4		- Set the possibility to reset or to maintain the contact in the ON position after an event.
	Input	- Polarity: active low / high - Function: list - Delay: 0.01s...100s (step 0.01s)	- Allow selection of the input status. - Allow selection of the events to associate to the input presence. - Set the event delay associated to input.

For more details refer to the description of the module, starting from para. 12.4.



WARNING: With unit in Remote status, all parameters and settings are in read-only mode, except for the setting Local / Remote (available to user).

With unit in Local status, all parameters and settings are in read-only mode.



WARNING: Use the address "modbus Standard" only

12.3.5.4. Datalogger

On this section is possible to set the Datalogger function parameters.

The data logger function can be used to save the instantaneous values of certain analog and digital measurements automatically in a large-sized memory buffer. The data can easily be downloaded from the unit using either application with external module (BT030-USB and Ekip T&P) or optional module (PR120/D-M), and transferred to any personal computer for processing.

The function allows the event to be set for recording stop, the sampling frequency and the stop delay, in order to facilitate failure analysis.

Setting	Range Value	Description
Presence	Enable / Disable	Determines the presence of the protection.
Sampling Frequency	600Hz / 1200Hz / 2400Hz / 4800Hz	Determines the Sampling frequency of the signals
Stop Event	List	Allow selection of the event for recording stop for storage
Stop Delay	0s...10s (step 0.01s)	Allow setting a delay for the recording
Restart	Command	Allow reset of data recorded, and to restart the datalogger
Stop	Command	Stop recording.

By using Ekip Connect software it is possible to download the recording and to read the data.

The data logger measurements are recorded in a time window, the duration of which is defined and synchronized by an event (trigger/ stop event) of your choice. The following figure displays the time window, the trigger and the samples available in grey:

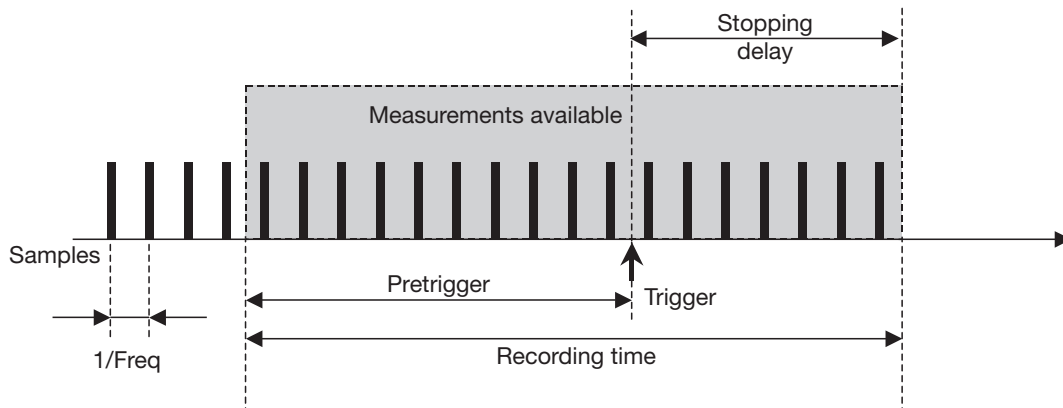

Model	B2342	B2410		Apparatus	Emax VF	Scale
				Doc. No	1SDH000909R0001	Page No 43/66

Depending on the selection made, the stopping delay may be nil, or it may be lower or higher than the recording time, as illustrated in the following figure:

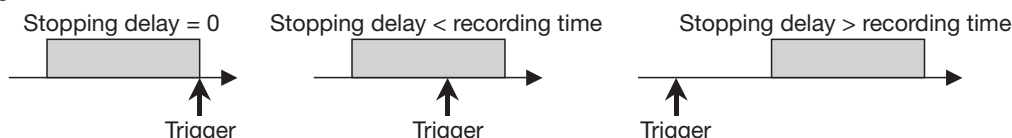

Maximum recording time is established by the sampling frequency set only; recording time may be lower than maximum time attainable when the sum of stopping delay and time elapsing between a restart trigger and a trigger is lower than the maximum value, as described in the figure below:

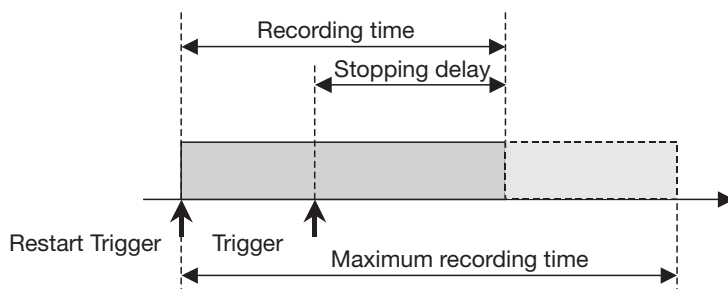

WARNING: If the parameters relating to the data logger are changed while it is operating, the recording under way is terminated and a new recording begins (after a restart trigger command) on the basis of the new parameters.

WARNING: In the event of a trip, this data storage process is stopped after 10 ms, even if a longer stopping delay has been selected.
For Datalogger ICON details see paragraph on Working ICON.

12.3.5.5. Measure Store Time

In this section is possible to set the Measure Store Time, to determinate the frequency of measurement recording. It is possible to choose values within the range 5min...120min (step 5min).

12.3.5.6. System

In this section is possible to set the trip unit parameters related to date, time, language, and password.

Setting	Range Value	Description
Date	Starting from 31/12/1999	User can set date.
Time	00.00...23.59 (step 1min)	User can set clock.
Language	Italiano, English, Francais, Deutsch, Espanol	User can select the language of the unit.
New Password	0000....9999	User can change the password.

WARNING: With unit turned OFF for more than 48hours, Date will reset, and it is necessary to enter a new value (incorrect value will be displayed on the bottom part of display).

WARNING: To change Language it is necessary to have CB in OPEN status.
To change the password it is necessary to confirm the new value twice.

12.3.5.7. Display contrast

In this section is possible to set the Display contrast, from 0% (all blank) to 100% (all black). Default setting: 30%. We do not advice setting contrast values lower than 20% or higher than 40%.

12.3.6. Test

The description of all the parameters and settings available to the user in the Test area.

12.3.6.1. CB Status

Here it is possible to view the CB status. There are 3 possible states: OPEN, CLOSE, UNDEFINED.

12.3.6.2. Autotest

Autotest function will start the automatic test of the leds and display.

12.3.6.3. Trip Test

It is possible to check the trip coil is working correctly. This test can be performed from the test menu, pushing the iTest button and then the ENTER button. The test can be done only without current in the power circuit. .

12.3.6.4. COM Module

In this menu it is possible to check the CB Status (refer to State of springs and Position of CB) and to send the command to YO and YC installed on CB.

WARNING: To perform Test of YO and YC command, CB must be in position= Inserted.
PR122/VF does not give the result of the tests, but only sends a command (the user must to check the action of the CB).

Model	B2342	B2410		Apparatus	Emax VF	Scale
				Doc. no.	1SDH000909R0001	Page No 44/66

12.3.6.5. SIGNALLING Module

In this menu it is possible to check the Input Status and to perform the autotest of the frontal LED, and related contact.

12.3.7. About this section

In this section it is possible to view the main CB and trip unit information.

12.4. Modules

12.4.1. PR120/D-M

The optional module PR120/D-M is the dedicated communication module for connecting the trip unit to a Modbus network, and for remote supervisory and control activities on the circuit-breakers.

The front of the trip unit features 3 LEDs:

- Power: if the AUX is present and the unit is correctly turned ON.
- Tx: During communication this LED will blink. Data direction: from trip unit to external. Without communication on bus, the LED is turned ON.
- Rx: during communication this LED will blink. Data direction: from external to trip unit. Without communication on bus, the LED is turned OFF.

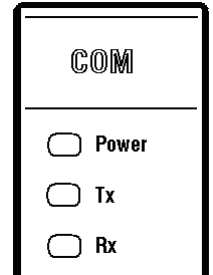

12.4.2. PR120/K

The optional module PR120/K is the dedicated contact module to extend the performing of trip unit input/output. The module enables the local signaling of alarms and CB trips.

There are two possible configurations for the SIGNALLING module:

- default configuration: 1 digital input programmable, 3 contacts with pole in common, 1 independent contact;
 - alternative configuration: 4 independent contacts. In this case, the digital input is wired, but not brought up to the terminal block.
- The two configurations are alternative to each other. You can switch from one configuration to the other without changing the module, by using a different wiring, as illustrated in the wiring diagrams.

The frontal of the trip unit features 5 LEDs:

- Power: if the AUX is present and the unit is correctly turned ON.
- 1: report the status of contact 1: LED turned ON means Contact 1 closed.
- 2: same function of 1, related to contact 2.
- 3: same function of 1, related to contact 3.
- 4: same function of 1, related to contact 4.

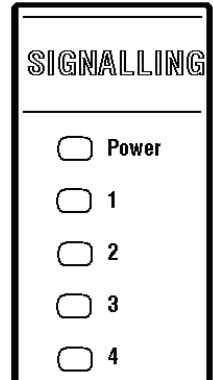

No LED is used to show the status for Digital input.

12.4.2.1. Digital Input

The unit enables the digital input to be associated with the following functions:

- outside trip control;
- zeroing release trips;
- resetting PR120/K contacts;
- local/remote enabling;
- for the load control function, the module can be used as an actuator.

To enable the Input, provide a signal 24Vdc ±20%.

There is an input with a configurable function in the Signalling module. The figure shows two cases, A and B, in which the input status is active; in case A the input does not stay valid beyond the enabling delay so the associated action does not take place, whereas in case B the action takes place after the preset delay.

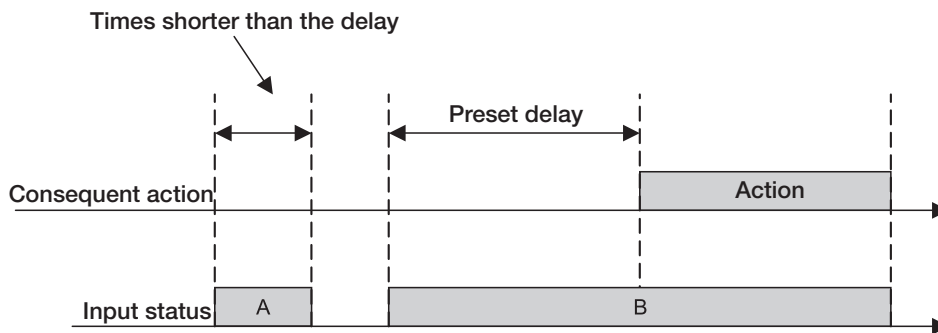

You can select the action associated with the input, i.e. the action that takes place after the programmed delay, when the input is enabled.

You can select one of the following actions:

- Generic: no specific action is associated with the input. The status of the input is shown on the available display and remotely via the bus.
- Trip test: when the input is enabled for the specified delay, a trip test is performed.
- Trip reset: when the input is enabled for the specified delay a trip reset is performed.
- Dial Local: when the input is enabled for the specified delay, there is a forcing of the dialogue local mode.
- Signalling module reset: when the input is enabled for the specified delay, the status of the relays in the PR120/K module is reset.
- Energy reset: when the input is active for the specified delay, the energy meters are reset.

Through the "Delay" parameter, you can specify the time to elapse before the input is enabled within the range 0s...100s (step 0.01s).

Model	B2342	B2410		Apparatus	Emax VF	Scale
				Doc. No	1SDH000909R0001	Page No 45/66

12.4.2.2. Output Contact

The unit enables the output contact to be associated with the following functions:

- None (none enabled);
- L prealarm (L protection prealarm).
- L timing (L protection timing).
- L trip (L protection trip).
- I trip (I protection trip).
- Any trip (tripping of any protection).
- Any alarm (timing of any protection).
- Load LC1 (load control LC1 alarm).
- Load LC2 (load control LC2 alarm).

By using Ekip Connect software it is possible to select more events, in the section CUSTOM. Here you can also combine some events using “and” / “or” logical functions. For more detailed information, refer to the Modbus Interface document.

The External Contacts support the following features:

Type of contact	SPST	
Max switching voltage	130 VDC	380 VAC
Max switching current	5 A	8 A
Max switching power	175 W	2000 VA
Breaking capacity at 35 VDC	5 A	----
Breaking capacity at 120 VDC	0,2 A	----
Breaking capacity at 250 VAC	----	8 A
Breaking capacity at 380 VAC	----	5,2 A
Contact/coil insulation	4000 Vrms	
Contact/contact insulation	1000 Vrms	

Each contact can be set has NO / NC, it is possible to enter an event reaction delay, and the latch option (with the contact “ON”, once it has been activated it remains switched). The contacts can be reset using input, or by remote.

12.4.3. PR030/B

The PR030/B power supply module is an external unit allowing temporary powering of the trip unit. It can be used with trip unit turned off, to check or change settings, parameters, and perform CB and trip unit Tests.

The PR030/B unit is provided with trip unit with a 9V battery inside.



WARNING: Before putting the CB into service, ABB suggests checking the presence of errors on PR122/VF with PR030/B battery unit and the performance of a Trip Coil test.



WARNING: To check the level of the battery inside the PR030/B, push the button on the unit. If turned ON, it is possible to use unit PR030/B correctly. Otherwise, change the battery.

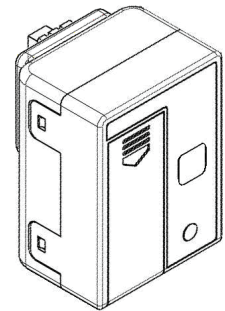

12.4.4. BT030-USB

The BT030-USB module is an external unit for Bluetooth and USB communication, and temporary power supply to the electronic trip unit.

The BT030-USB module is not provided with trip unit.

The device is supplied with:

- a USB cable (A to mini B).
- CD containing the ABB communication SW Ekip Connect.



WARNING: BT030-USB module must be used for communication with SW Ekip connect only. For further details see document: 1SDH000796R0001

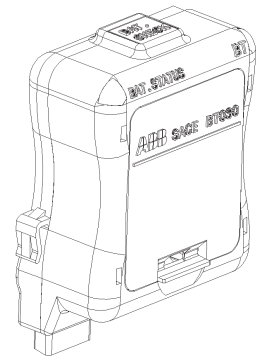

Model	B2342	B2410		Apparatus	Emax VF	Scale
				Doc. no.	1SDH000909R0001	Page No 46/66

12.4.5. Ekip T&P

The Ekip T&P is an external unit that can be connected to a PC (USB connection), for communication and test of the trip unit.

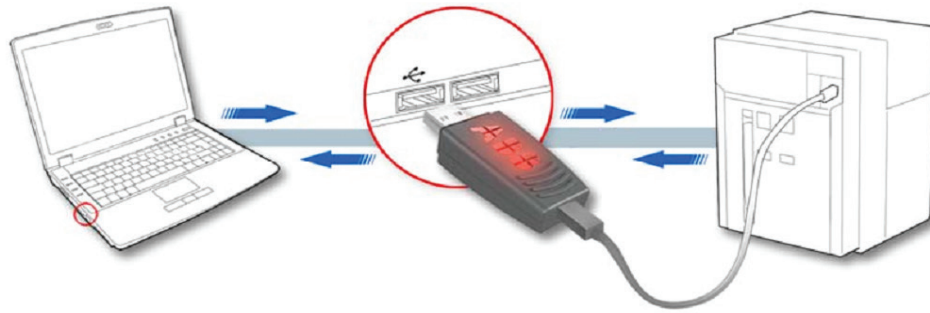

With the Ekip T&P testing unit it is possible to simulate a fault condition in order to evaluate the PR122/VF operation, according to the protection settings.



WARNING: Ekip T&P must be used with USB module, and the special cable for connection to the PR122/VF front connector for testing (the picture above shows only a graphic example of Ekip T&P connection). For further details, see document: 1SDH000891R0002

12.4.6. Ekip Connect

Ekip Connect is a software application for personal computers using Microsoft Windows® operating systems which allows data to be exchanged with one or more ABB low voltage appliances.

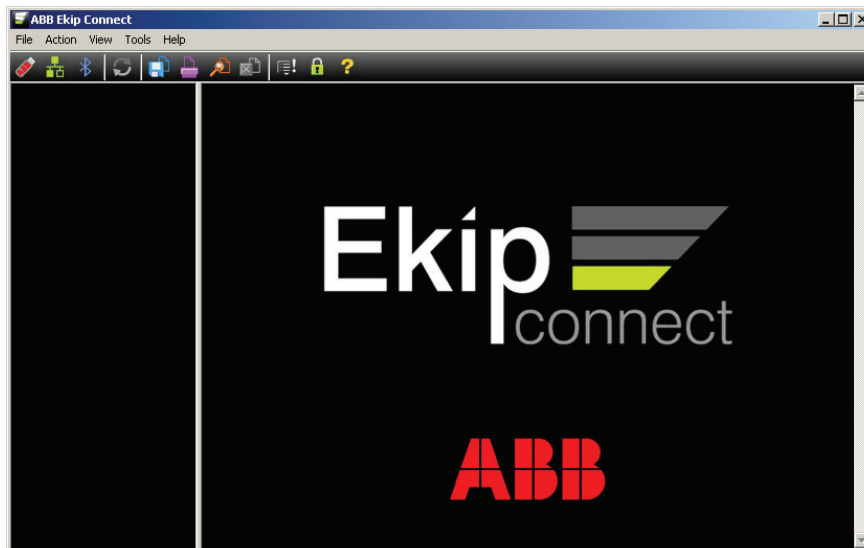

In particular, Ekip Connect supports the connection of ABB automatic low voltage circuit breakers fitted with an electronic trip unit in order to:

- Set up
- Monitor status
- Read information (alarms, measurements, parameters)
- Modify configuration parameters, above all for trip units which do not feature a display
- Carry out commands
- Find faults in the communication network
- Carry out tests

Ekip Connect proves useful in a variety of phases during the life cycle of the trip unit:

1. Set up
2. Configuration
3. Monitoring
4. Maintenance and testing

Thanks to the possibility of carrying out a scan of the communications network and the possibility of saving parameters and test reports, the software also assists the process of operative testing of a switchboard

Ekip Connect is distributed on CD, or is available to download from the internet at the address <http://bol.it.abb.com> in the section "Work Tools - Circuit breakers software download area".

Model	B2342	B2410		Apparatus	Emax VF	Scale
				Doc. No	1SDH000909R0001	Page No 47/66

12.5. Default Settings

The PR122/VF is supplied by ABB SACE with the following predefined parameters:

#	Protection/function	Status	Default Settings
1	L	ON (not disabled)	1 In; 102 s
2	I	ON	4 In
3	I Startup	OFF	4 In; 100 ms
4	OT	Trip Enable= DISABLE	--
5	LC1	OFF	50% I ₁
6	LC2	OFF	75% I ₁
7	Iw	OFF	3 In
8	Nominal Frequency	25 Hz	
9	Data Logger	OFF	
10	Measure store time	--	60min
11	Language	--	English
12	Password	--	0001
13	Display Contrast	--	30 %

12.6. Help

12.6.1. Error Messages

If some operations cannot be performed on unit, a pop-up message is displayed. The following is a description of these messages:

Error Message	Description
Password error	
Session impossible	A programming session cannot be started due to a contingency (e.g. a timer-controlled delay still elapsing)
Value outside range	Value beyond the established limits
Exception 6	Command temporarily unavailable
Unavailable	Function temporarily unavailable
Invalid date	Date has not been set
Parameters revised	Programming session concluded correctly
Cancelled	Programming session cancelled
Failed	Programming session rejected
Failed 3001	Inconsistency as to language change

Model	B2342	B2410		Apparatus	Emax VF	Scale
				Doc. no.	1SDH000909R0001	Page No 48/66

12.6.2. Troubleshooting

The following table lists a series of typical service conditions, to help you understand and solve hypothetical faults or malfunctions.



WARNING: Before consulting the following table, check for any error messages appearing for some seconds on the display. For FN will be indicated the correct functioning of the PR122/VF. If the suggested action does not lead to a solution of the problem, please contact the ABB SACE assistance service.

#	Situation	Possible cause	Suggestion
1	The trip test cannot be run	1. The busbar current is > 0 2. The TC is not connected 3. AUX missing	1. FN 2. Check message on Display. 3. FN
2	Trip times lower than expected	1. Threshold too low 2. Curve too low 3. Unstable value of AUX	1. Correct threshold 2. Correct curve 3. Check the AUX value stability
3	Trip times higher than expected	1. Threshold too high 2. Curve too high	1. Correct threshold 2. Correct curve
4	Display off	1. Faulty voltage sockets connection 2. AUX missing 3. Temperature out of range	1. Check the socket connection 2. FN 3. FN
5	The display is not back-lit	1. AUX ON, but below limit AUX-20%. 2. AUX OFF, and Frontal unit connect- ed	1. Check AUX 2. FN
6	I Reading out of accuracy	Current below the minimum threshold, or current out of range or current distor- tion out of range.	FN
7	Message "" instead of expected data	Function disabled or data out of range	FN
8	The expected trip does not occur	Trip function disabled	FN enable trip if necessary
9	After a trip and iTest use, no display of the opening data	AUX missing, and the buffer capacitor is discharged	FN if more than 48h has elapsed
10	The password is not requested	The password has been disabled	FN, re-enter the password with a value other than 0000
11	Impossible to change any parameter from display menu	1. PR122/VF in alarm situation 2. Unit in Remote configuration	1. FN 2. FN
12	"Temp. sensor" or "Start-up" message	Possible failure inside trip unit	Contact ABB Sace
13	Invalid date	First installation or information lost	Set Date
14	Language cannot be changed	CB not open	Open CB

In case of fault, follow the instruction below:

- Make a note of the type of protection that has tripped by accessing the LAST TRIP page if there is an external power supply (AUX or external unit from frontal connector) or by pressing "i Test".
- Note down the type of CB, any accessories connected, the nominal current, trip unit Serial Number and the SW version.
- If possible use the function available with Ekip connect that makes the complete page report.
- Prepare a brief description of the opening (what LEDs and/or indications were displayed? when did it happen?, how many times ?, was it always under the same conditions? what type of load? what voltage? what current? is the event reproducible?)
- Send/communicate all the information collected, together with the circuit diagram for the circuit-breaker, to your nearest ABB Customer Support service.



WARNING: If you suspect that the PR122/VF is faulty, has a malfunction or has generated an unwanted trip, it is advisable to follow the recommendations above very carefully, referring the trip history.

The completeness and accuracy of the information given to the ABB Assistance service will facilitate technical analysis of the problem encountered, and will allow us rapidly carry out all actions to help the user.

Model	B2342	B2410		Apparatus	Emax VF	Scale
				Doc. No	1SDH000909R0001	Page No 49/66

13. Overall dimensions

Fixed circuit-breaker

Basic version with horizontal rear terminals

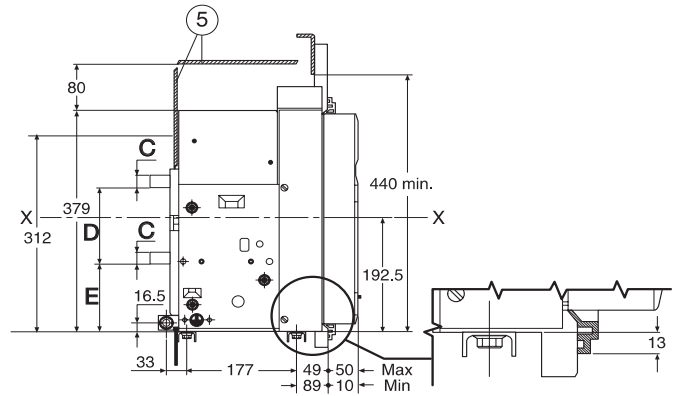
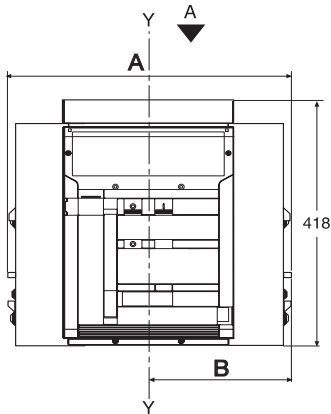

Legend

- ① Inside edge of compartment door
- ② Segregation (where foreseen)
- ③ Circuit-breaker M10 fixing drilling (use M10 screws)
- ④ N° 1 M12 screw (E2, E3) for earthing (included in the supply)
- ⑤ Insulating or metal-insulated wall

E2
View A

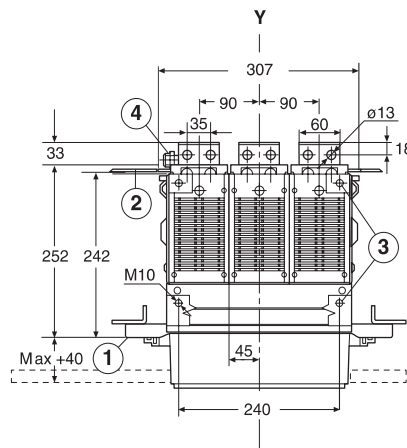

E3
View A

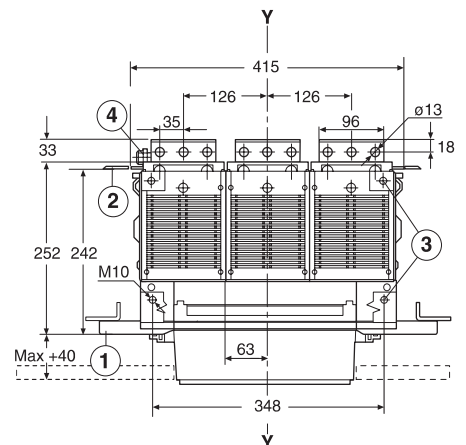

	A	B	C	D	E
E2	296	148	26	114	117,5
E3	404	202	26	114	117,5

Model	B2342	B2410		Apparatus	Emax VF	Scale
				Doc. no.	1SDH000909R0001	Page No 50/66

Fixed circuit-breaker

Basic version with vertical rear terminals

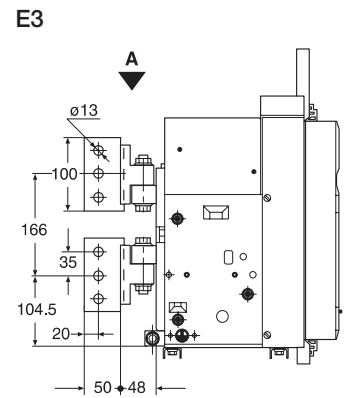
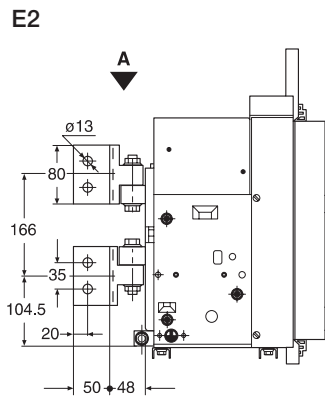

E2
View A

E3
View A

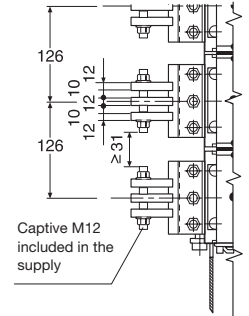
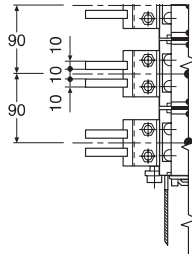
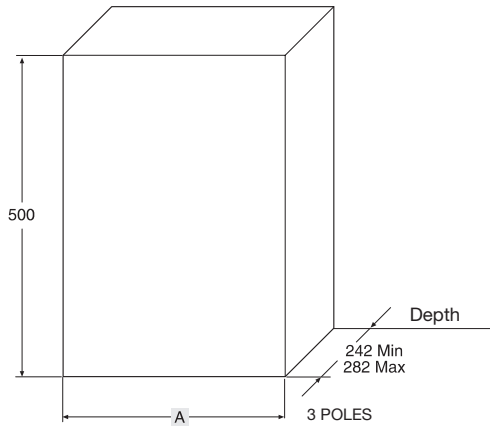

Fig. 36a

Model	B2342	B2410		Apparatus	Emax VF	Scale
				Doc. No	1SDH000909R0001	Page No 51/66

Compartment dimensions



Compartment door drilling

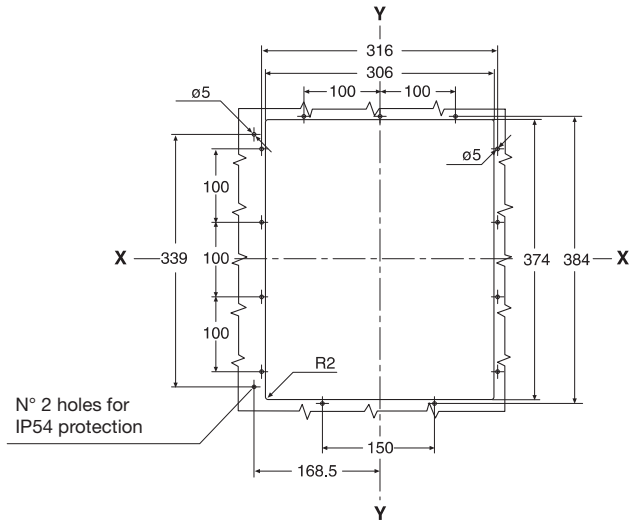

Holes for passing through flexible cables for mechanical interlocks

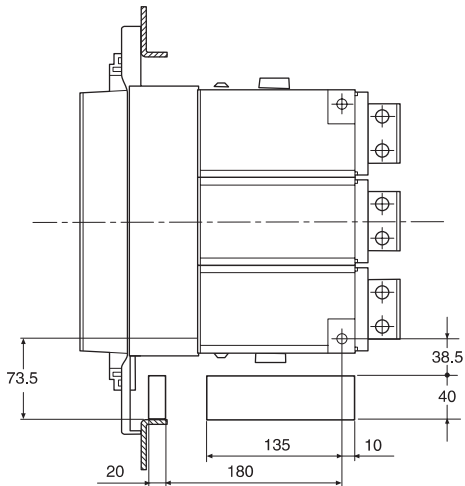

Tightening torque of the main terminals: Nm 70
Tightening torque of the earthing screw: Nm 70

		High resistance M12 screw Quantity for terminal
		PHASE
	E2	2
	E3	3

A	
E2	400
E3	500

Fig. 39

Model	B2342	B2410		Apparatus	Emax VF	Scale
				Doc. no.	1SDH000909R0001	Page No 52/66

Withdrawable circuit-breaker

Basic version with horizontal rear terminals

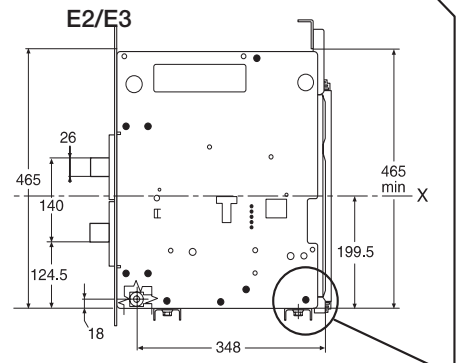
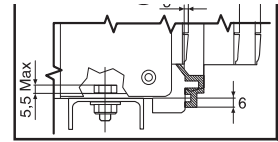
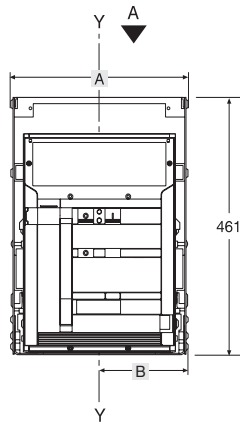

Legend

- ① Inside edge of compartment door
- ② Segregation (where foreseen)
- ③ Fixing fixed part $\varnothing 10$ drilling (use M8 screws)
- ④ N° 1 M12 screw (E2, E3) for earthing (included in the supply)
- ⑤ Run from connected for a TEST to isolated
- ⑥ Alternative drilling with 25mm pitch for fixing fixed part
- ⑦ Ventilation drilling on the switchgear

E2 View A

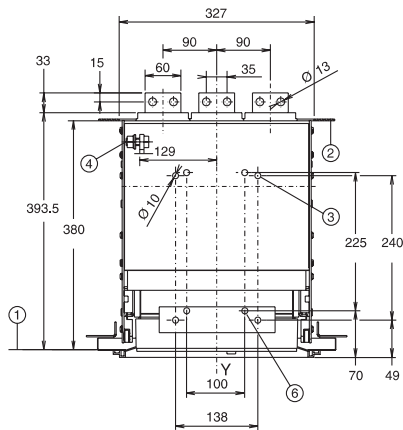

E3 View A

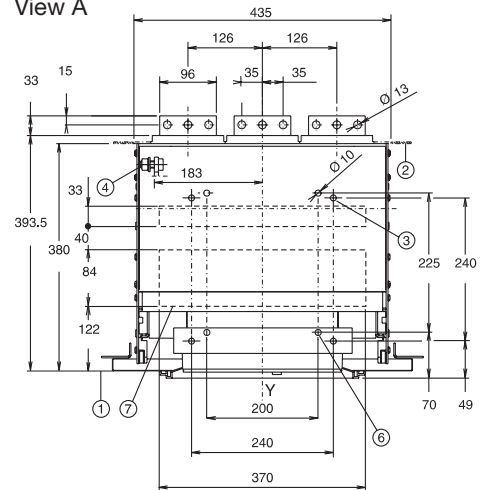

	A	B
E2	324	162
E3	432	216

Fig. 40

Model	B2342	B2410	Apparatus	Emax VF	Scale
			Doc. No	1SDH000909R0001	Page No 53/66

Withdrawable circuit-breaker

Basic version with vertical rear terminals

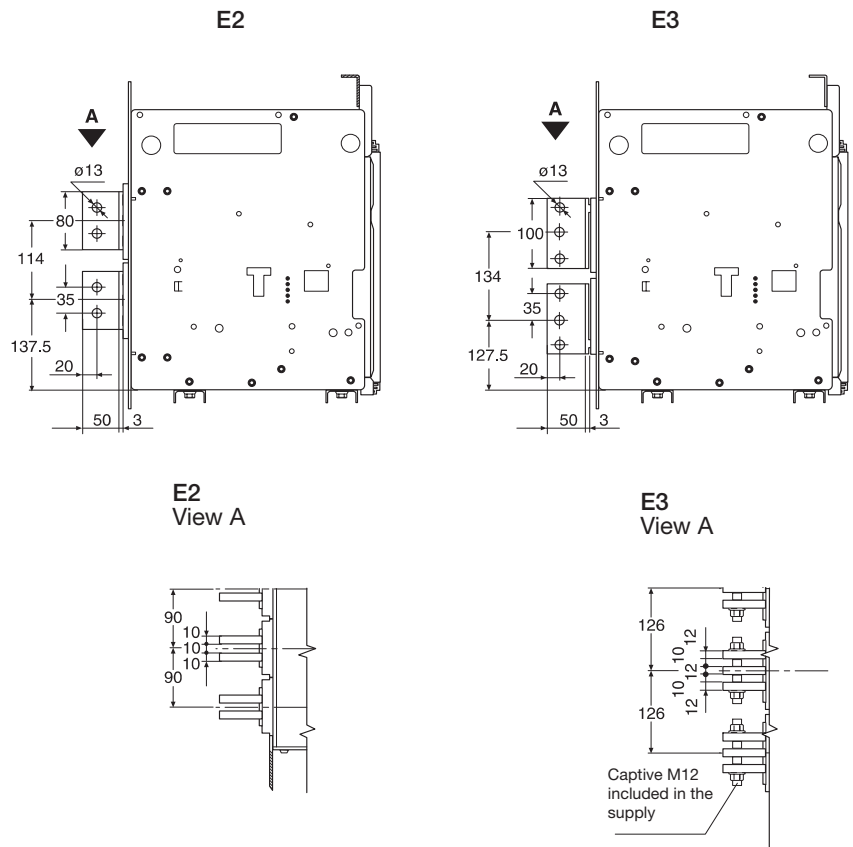
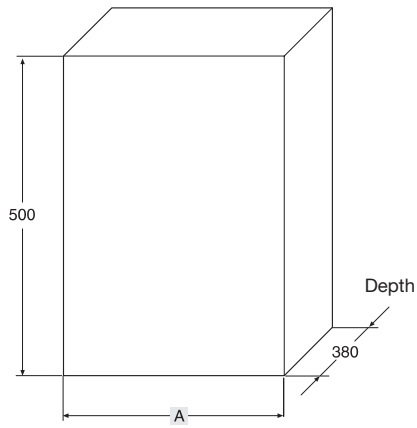

Fig. 42

Model	B2342	B2410		Apparatus	Emax VF	Scale
				Doc. no.	1SDH000909R0001	Page No 54/66

Compartment dimensions



Compartment door drilling

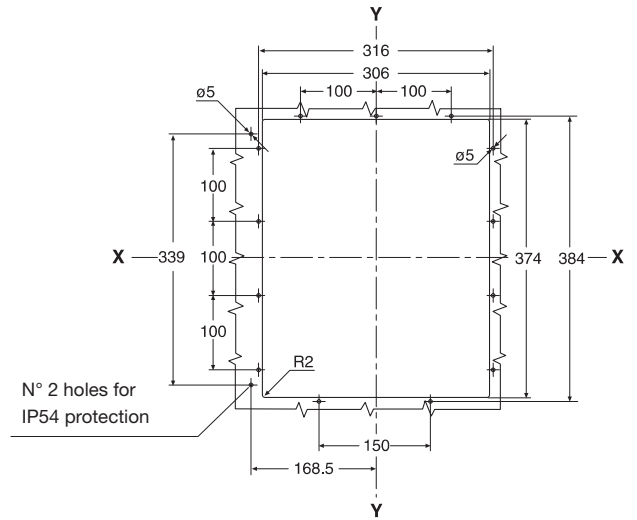

Holes for passing through flexible cables for mechanical interlocks

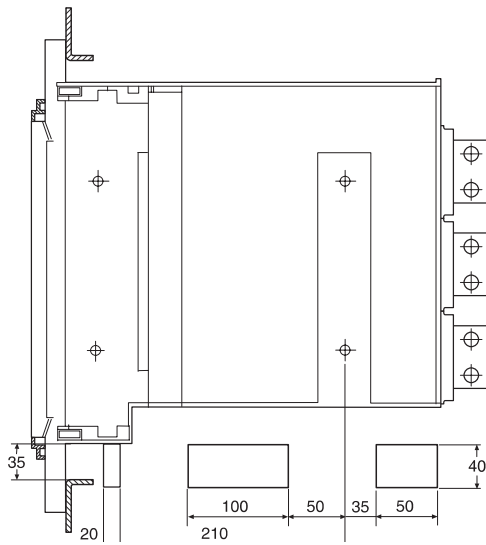

Tightening torque of the fixing screws: 20 Nm
 Tightening torque of the main terminals: 70 Nm
 Tightening torque of the earthing screw: 70 Nm

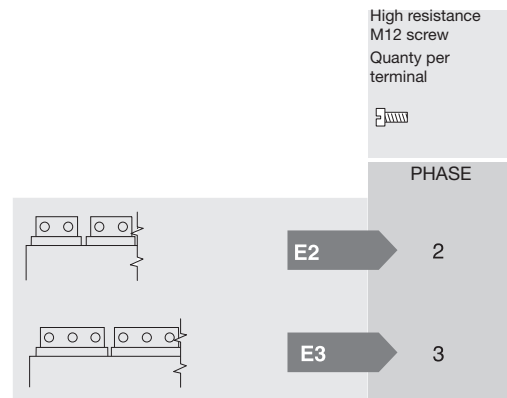

A	
E2	400
E3	500

Fig. 46

Model	B2342	B2410	Apparatus	Emax VF	Scale
			Doc. No	1SDH000909R0001	Page No 55/66

Compartment door mechanical lock

Door drilling

Minimum distance between the circuit-breaker and the switchgear wall

Fixed version

Withdrawable version

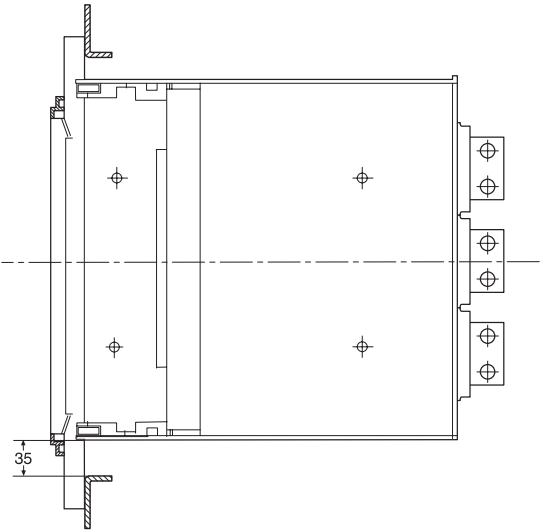
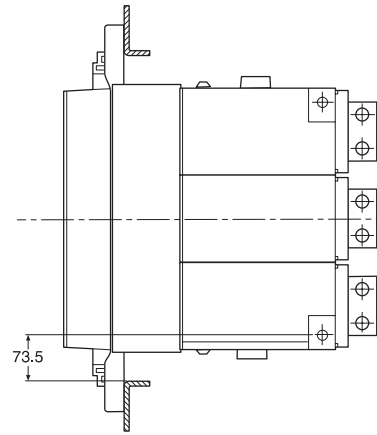
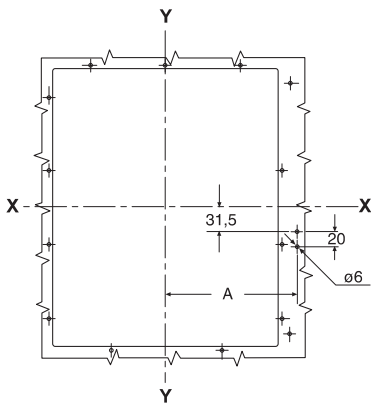

A

E2 180

E3 234

Fig. 47

Model	B2342	B2410		Apparatus	Emax VF	Scale
				Doc. no.	1SDH000909R0001	Page No 56/66

14. Circuit diagrams



WARNING:

Without the auxiliary power supply 24V DC the trip unit does not work and the circuit breaker is not protected. Before installing the circuit-breaker, carefully read note F on the circuit diagrams.

Operating status shown

The circuit diagram is for the following conditions:

- withdrawable circuit-breaker, open and racked-in
- circuits de-energised
- releases not tripped
- motor operating mechanism with springs unloaded.

Versions

The diagram shows a circuit-breaker in withdrawable version; it can be applied to a fixed version circuit-breaker as well.

Fixed version

The control circuits are fitted between terminals XV (connector X is not supplied).
With this version, the applications indicated in figures 31 and 32 cannot be provided.

Withdrawable version

The control circuits are fitted between the poles of connector X (terminal box XV is not supplied).

14.1. Caption

- = Circuit diagram figure number
- * = See note indicated by the letter
- A1 = Circuit-breaker accessories
- A3 = Accessories applied to the fixed part of the circuit-breaker (for withdrawable version only)
- A4 = Example switchgear and connections for control and signalling, outside the circuit-breaker
- AY = SACE SOR TEST UNIT Test/monitoring Unit (see note R)
- D = Electronic time-delay device of the undervoltage release, outside the circuit-breaker
- F1 = Delayed-trip fuse
- K51 = PR122/VF electronic release with the following protection functions:
 - L overload protection with inverse long time-delay trip-setting I1
 - I short-circuit protection with instantaneous time-delay trip-setting I3
- K51/IN1 = Digital programmable input (available only with module PR120/K)
- K51/P1...P4 = Programmable electrical signalling (available only with module PR120/K)
- K51/YC = Closing control from PR122/VF electronic release with communication module PR120/D-M
- K51/YO = Opening control from PR122/VF electronic release with communication module PR120/D-M
- M = Motor for loading the closing springs
- Q = Circuit-breaker
- Q/1...27 = Circuit-breaker auxiliary contacts
- S33M/1...3 = Limit contacts for spring-loading motor
- S43 = Switch for setting remote/local control
- S51 = Contact for electrical signalling of circuit-breaker open due to tripping of the overcurrent release. The circuit-breaker may be closed only after pressing the reset pushbutton, or after energizing the coil for electrical reset (if available)
- S75E/1.4 = Contacts for electrical signalling of circuit-breaker in disconnected position (only with withdrawable circuit-breakers)
- S75I/1.5 = Contacts for electrical signalling of circuit-breaker in connected position (only with withdrawable circuit-breakers)
- S75T/1.4 = Contacts for electrical signalling of circuit-breaker in test isolated position (only with withdrawable circuit-breakers)
- SC = Pushbutton or contact for closing the circuit-breaker
- SO = Pushbutton or contact for opening the circuit-breaker
- SO1 = Pushbutton or contact for opening the circuit-breaker with delayed trip
- SO2 = Pushbutton or contact for opening the circuit-breaker with instantaneous trip
- SR = Pushbutton or contact for electrical circuit-breaker reset
- Vaux = Auxiliary power supply voltage (see note F)
- W1 = Serial interface with control system (external bus): EIA RS485 interface (see note E)
- W2 = Serial interface with the accessories of PR122/VF releases (internal bus)
- X = Delivery connector for auxiliary circuits of withdrawable version circuit-breaker
- X1...X7 = Connectors for the accessories of the circuit-breaker
- XF = Delivery terminal box for the position contacts of the withdrawable circuit-breaker (located on the fixed part of the circuit-breaker)
- XK1 = Connector for power circuits of PR122/VF releases
- XK2 - XK3 = Connectors for auxiliary circuits of PR122/VF releases
- XK10 - XK12 = Connectors for power circuit of PR122/VF releases
- XK4 = Connector to signal open/close
- XO = Connector for YO1

Model	B2342	B2410		Apparatus	Emax VF	Scale
				Doc. No	1SDH000909R0001	Page No 57/66

- XV = Delivery terminal box for the auxiliary circuits of the fixed circuit-breaker
- YC = Shunt closing release
- YO = Shunt opening release
- YO2 = Second shunt opening release (see note Q)
- YR = Coil to electrically reset the circuit-breaker
- YU = Undervoltage release (see notes B and Q)

14.2. Description of figures

- Fig. 1 = Motor circuit to load the closing springs.
- Fig. 2 = Circuit of shunt closing release.
- Fig. 4 = Shunt opening release.
- Fig. 6 = Instantaneous undervoltage release (see notes B and Q).
- Fig. 7 = Undervoltage release with electronic time-delay device, outside the circuit-breaker (see notes B and Q)
- Fig. 8 = Second shunt opening release (see note Q).
- Fig.11 = Contact for electrical signalling of springs loaded.
- Fig.12 = Contact for electrical signalling of undervoltage release energized (see notes B and S).
- Fig.13 = Contact for electrical signalling of circuit-breaker open due to tripping of the overcurrent release. The circuit-breaker may be closed only after pressing the reset pushbutton.
- Fig.14 = Contact for electrical signalling of circuit-breaker open due to tripping of the overcurrent release and electrical reset coil. The circuit-breaker may be closed only after pressing the reset pushbutton or energizing the coil.
- Fig.21 = First set of circuit-breaker auxiliary contacts.
- Fig.22 = Second set of circuit-breaker auxiliary contacts (not available for PR122/P and PR123/P releases)(see note V)
- Fig.23 = Third set of supplementary auxiliary contacts outside the circuit-breaker.
- Fig.31 = First set of contacts for electrical signalling of circuit-breaker in connected, test isolated, disconnected position.
- Fig.32 = Second set of contacts for electrical signalling of circuit-breaker in connected, test isolated, disconnected position.
- Fig.42 = Auxiliary circuits of PR122/VF releases (see notes F and V).
- Fig.45 = Circuits of the communication module PR120/D-M of the PR122/VF releases (optional) (see note E).
- Fig.46 = Circuits of the indicator module PR120/K of the PR122/VF releases - connection 1 (optional) (see note V).
- Fig.47 = Circuits of the indicator module PR120/K of the PR122/VF releases - connection 2 (optional) (see note V).
- Fig.61 = SACE SOR TEST UNIT Test/monitoring Unit (see note R)

14.3. Incompatibilities

The circuits indicated in the following figures cannot be supplied simultaneously on the same circuit-breaker:

- 6 - 7 - 8
- 13 - 14
- 22 - 46 - 47







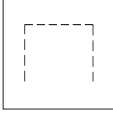
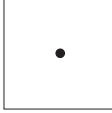
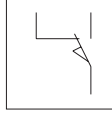
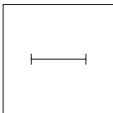
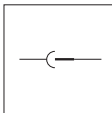
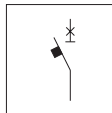

14.4. Notes

- A) The circuit-breaker is only fitted with the accessories specified in the ABB SACE order acknowledgement. Consult the technical catalogue for information on how to make out an order.
- B) The undervoltage release is supplied for operation using a power supply branched on the supply side of the circuit-breaker or from an independent source. The circuit-breaker can only close when the release is energized (there is a mechanical lock on closing).
If the same power supply is used for the closing and undervoltage releases and the circuit-breaker is required to close automatically when the auxiliary power supply comes back on, a 30 ms delay must be introduced between the undervoltage release accept signal and the energizing of the closing release. This may be achieved using an external circuit comprising a permanent make contact, the contact shown in fig. 12 and a time-delay relay.
- E) For connecting the EIA RS485 serial line, see "Technical Application papers – QT 9" communication via BUS with the ABB switches.
- F) The PR122/VF trip unit requires the external power supply to activate the protection functions and the ammeter. Without the auxiliary power supply 24V DC the trip unit does not work and the circuit breaker is not protected. It is recommended to use a backup battery to guarantee the presence of the Vaux or to add in the circuit breaker an undervoltage release (YU) to open the circuit breaker even when the auxiliary Vaux does not work. The external auxiliary power supply must be provided using a galvanically-separated power pack dedicated only for one trip unit. Since the auxiliary voltage needs to be isolated from the ground, "galvanically separated converters" in accordance with the IEC standard 60950 (UL 1950) or the equivalent IEC 60364-41 have to be used to guarantee a current in common mode or leakage current (as defined in IEC 478/1) no greater than 3,5 mA. The connections for the auxiliary power supply must be made with a two-pole shielded twisted cable (e.g. type BELDEN 3105A/3105B), the shield must be earthed on the trip unit side.
- P) With releases PR122/VF with communication module PR120/D-M, the coils YO and YC are controlled directly from contacts K51/YO and K51/YC with maximum voltages of 110-120 VDC and 240-250 VAC.
- Q) The second shunt opening release may be installed as an alternative to the undervoltage release.

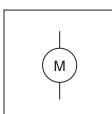
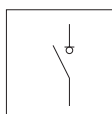
Model	B2342	B2410		Apparatus	Emax VF	Scale
				Doc. no.	1SDH000909R0001	Page No 58/66

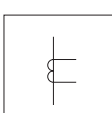
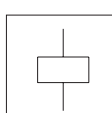
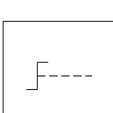
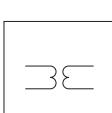
- R) The SACE SOR TEST UNIT + opening release (YO) is guaranteed to operate starting at 75% of the Vaux of the opening release itself.
 While the YO power supply contact is closing (short-circuit on terminals 4 and 5), the SACE SOR TEST UNIT is unable to detect the opening coil status.
 Consequently:
- For continuously powered opening coil, the TEST FAILED and ALARM signals will be activated
 - If the coil opening command is of the pulsing type, the TEST FAILED signal may appear at the same time. In this case, the TEST FAILED signal is actually an alarm signal only if it remains lit for more than 20s.
- S) Also available in the version with normally-closed contact
- V) If fig. 22 is present (second set of auxiliary contacts) the signalling module PR120/K in figures 46 and 47 cannot be supplied.

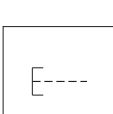
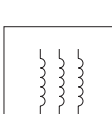
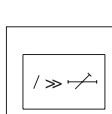
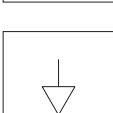
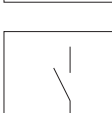
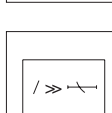
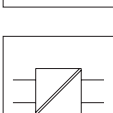
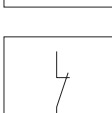
Circuit diagram symbols (IEC 60617 and CEI 3-14 ... 3-26 Standards)

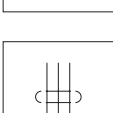
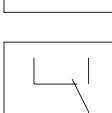
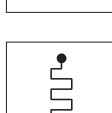
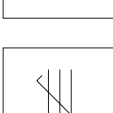
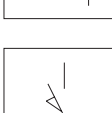
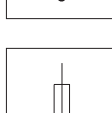
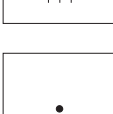
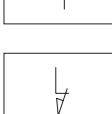
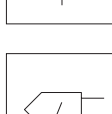
	Shield (may be drawn in any shape)		Terminal		Change-over position contact with momentary circuit breaking (limit contact)
	Time delay		Plug and socket (male and female)		Power isolator with automatic breaking action
	Mechanical or electrical connection		Motor (general symbol)		Switch-disconnector
	Manual mechanical control (general case)		Current transformer		Control coil (general symbol)
	Rotating control		Voltage transformer		Instantaneous overcurrent relay
	Pushbutton control		Winding of three-phase transformer, Star connection		Overcurrent relay with adjustable short time-delay trip
	Equipotentiality		Make contact		Overcurrent relay with inverse short time-delay trip
	Galvanically separated converter		Break contact with automatic circuit breaking		Overcurrent relay with inverse long time-delay trip
	Shielded cable conductors (i.e., 3 conductors shown)		Change-over contact		Current sensing resistors
	Conductors or stranded cables (i.e., 3 conductors shown)		Make position contact (limit contact)		Fuse (general symbol)
	Connection of conductors		Break position contact (limit contact)		Current sensor

Model	B2342	B2410		Apparatus	Emax VF	Scale
				Doc. No	1SDH000909R0001	Page No 59/66

Circuit diagram - Operating status

Three-pole circuit-breaker with PR122/VF electronic release

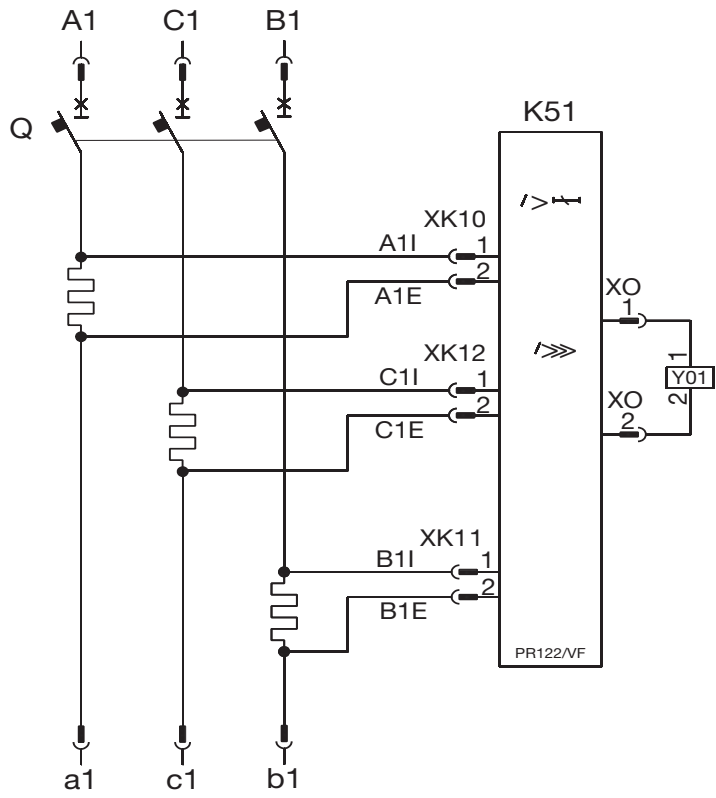

Model	B2342	B2410		Apparatus	Emax VF	Scale
				Doc. no.	1SDH000909R0001	Page No 60/66

Motor operating mechanism, opening, closing and undervoltage releases

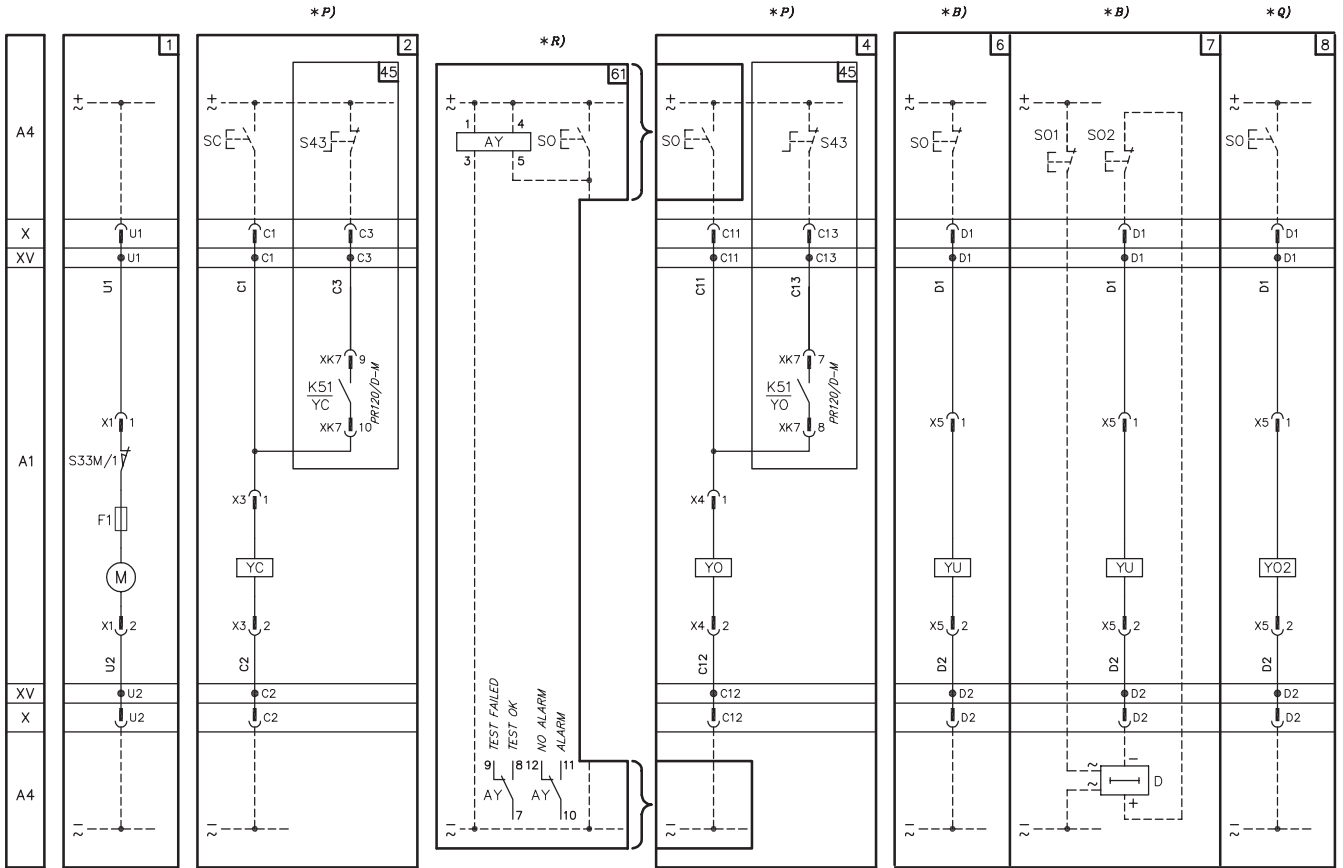

Signalling contacts

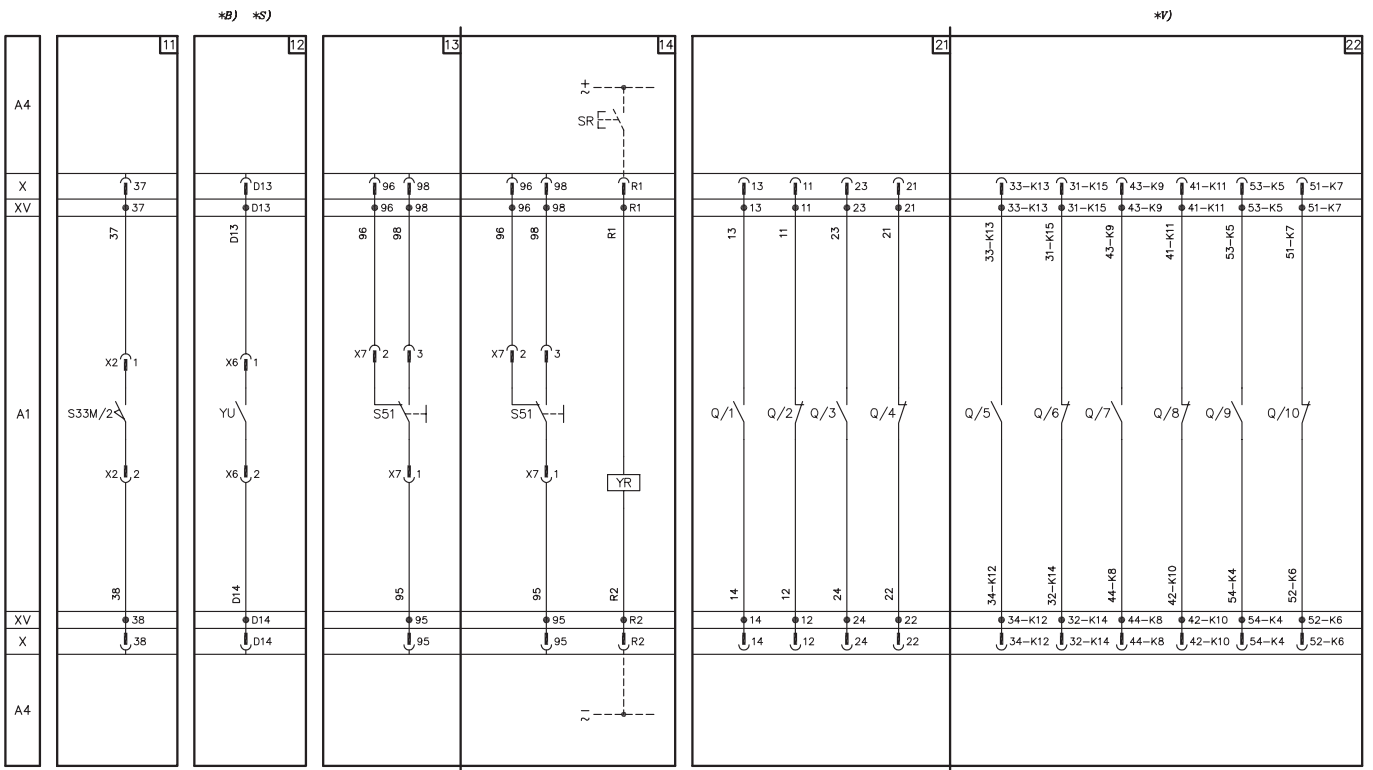

Model	B2342	B2410		Apparatus	Emax VF	Scale
				Doc. No	1SDH000909R0001	Page No 61/66

Signalling contacts

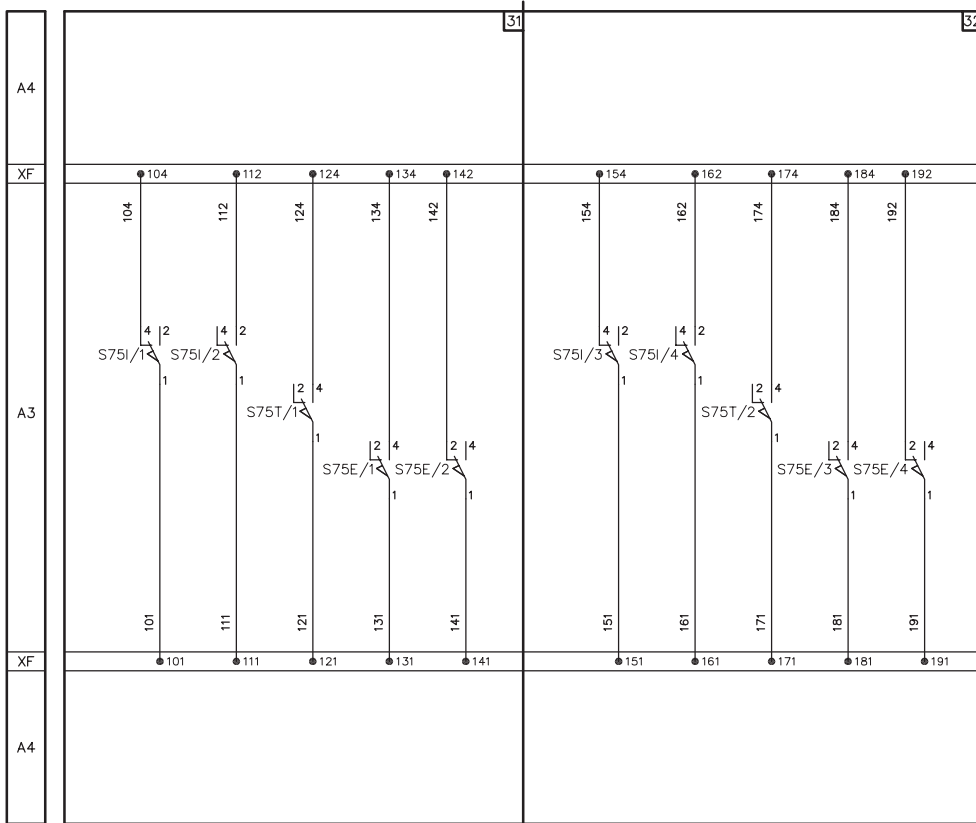
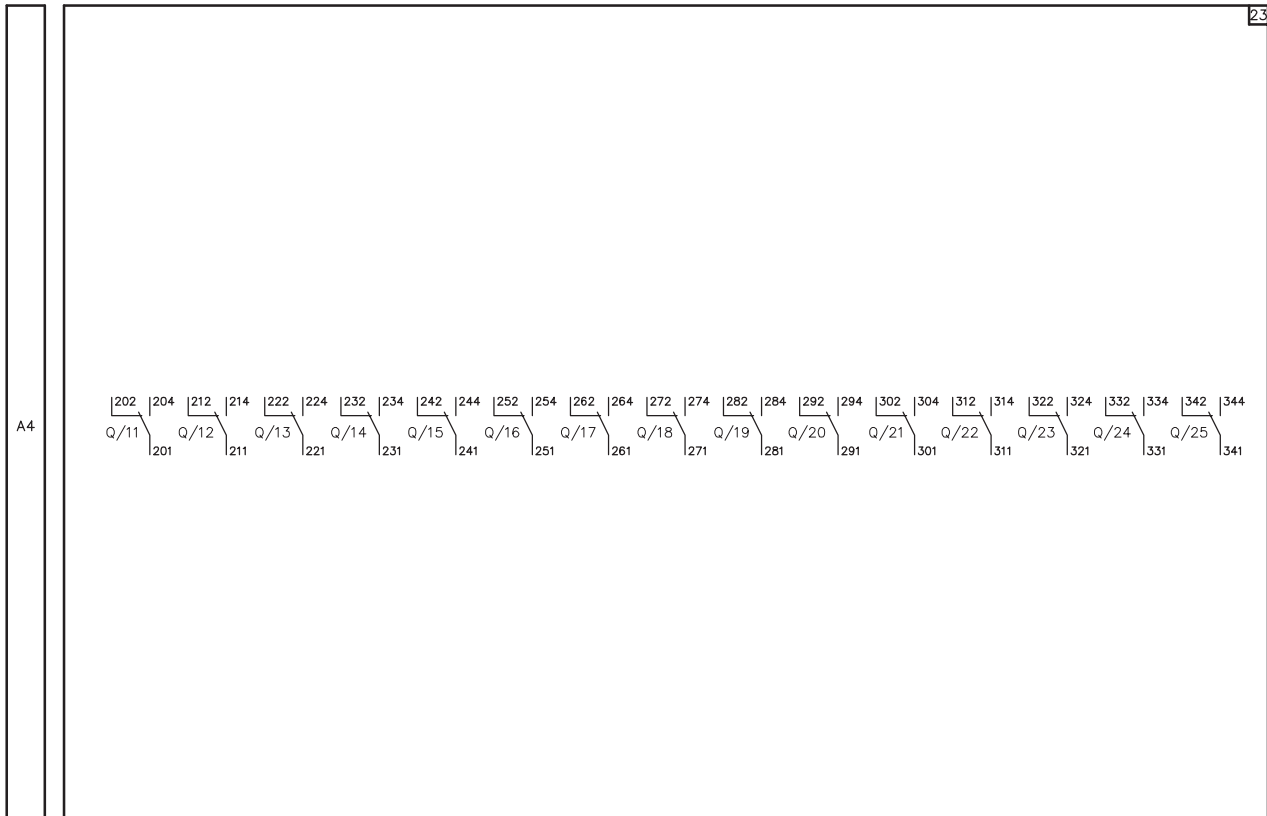

Model	B2342	B2410		Apparatus	Emax VF	Scale
				Doc. no.	1SDH000909R0001	Page No 62/66

Auxiliary circuits of the PR122/VF release

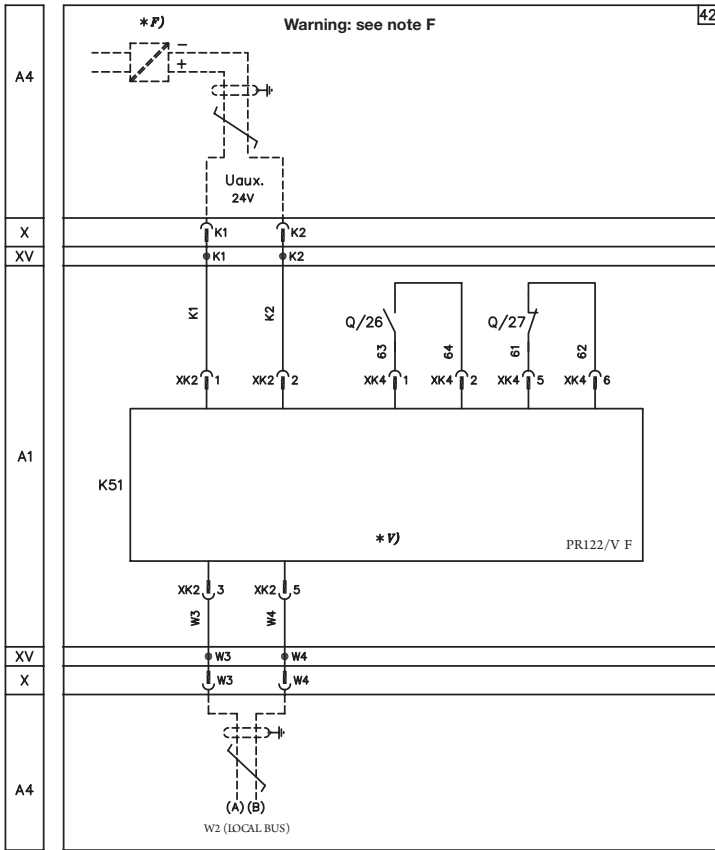

PR120/D-M communication module

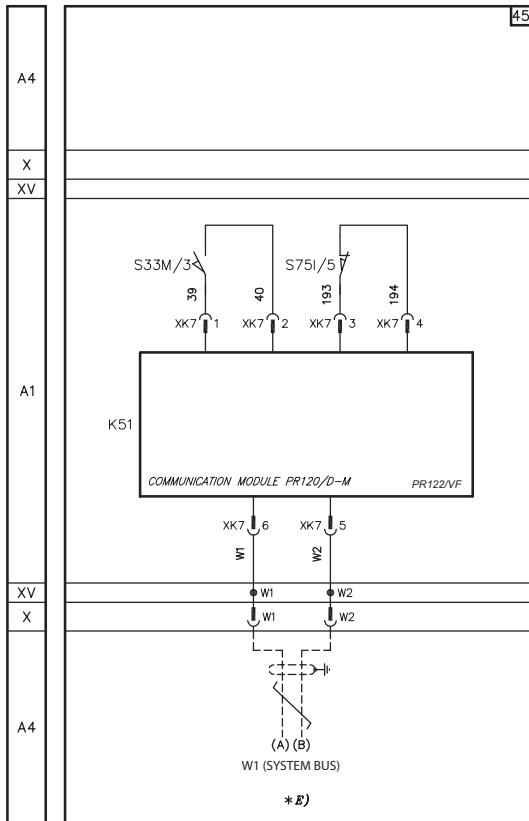

Model	B2342	B2410		Apparatus	Emax VF	Scale
				Doc. No	1SDH000909R0001	Page No 63/66

PR120/K signalling module

* V)

* V)

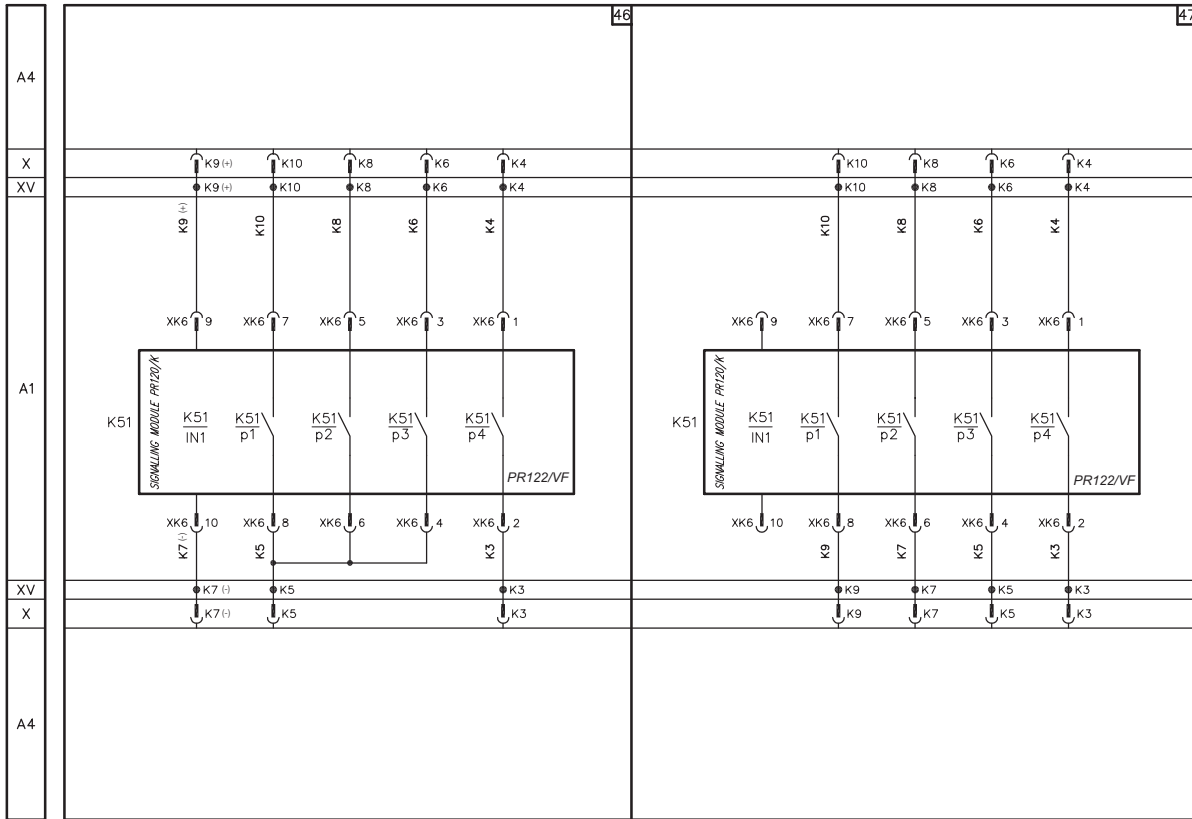

Model	B2342	B2410		Apparatus	Emax VF	Scale
				Doc. no.	1SDH000909R0001	Page No 64/66



ABB S.p.A.

Via Pescaria, 5

24123 Bergamo - Italy

Tel.: +39 035.395.111

<http://www.abb.com>

Due to possible developments of standards as well as of materials, the characteristics and dimensions specified in the present catalogue may only be considered binding after confirmation by ABB SACE.