

Line Series

# I-Line Track 250 to 630 A

Catalogue 2024  
High-flexibility busbar trunking system



[se.com](https://se.com)

Life Is On

**Schneider**  
Electric



# Green Premium™

An industry leading portfolio of offers delivering sustainable value



More than 75% of our product sales offer superior transparency on the material content, regulatory information and environmental impact of our products:

- RoHS compliance
- REACH substance information
- Industry leading # of PEP's\*
- Circularity instructions



Discover what we mean by green  
[Check your products!](#)

The Green Premium program stands for our commitment to deliver customer valued sustainable performance. It has been upgraded with recognized environmental claims and extended to cover all offers including Products, Services and Solutions.

### CO<sub>2</sub> and P&L impact through... Resource Performance

Green Premium brings improved resource efficiency throughout an asset's lifecycle. This includes efficient use of energy and natural resources, along with the minimization of CO<sub>2</sub> emissions.

### Cost of ownership optimization through... Circular Performance

We're helping our customers optimize the total cost of ownership of their assets. To do this, we provide IoT-enabled solutions, as well as upgrade, repair, retrofit, and remanufacture services.

### Peace of mind through... Well-being Performance

Green Premium products are RoHS and REACH compliant. We're going beyond regulatory compliance with step-by-step substitution of certain materials and substances from our products.

### Improved sales through... Differentiation

Green Premium delivers strong value propositions through third-party labels and services. By collaborating with third-party organizations we can support our customers in meeting their sustainability goals such as green building certifications.

\*PEP: Product Environmental Profile (i.e. Environmental Product Declaration)

# Contents

Introduction

A

Selection Guide and Description

B

Catalogue Numbers and Dimensions

C

Characteristics

D

Index

E

## Panorama of the range

A



B



C

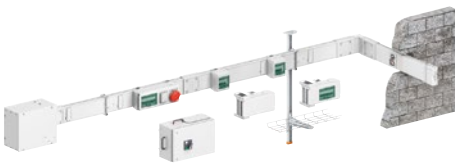

D

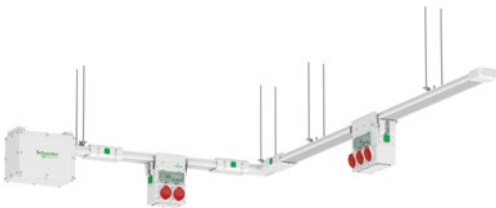

E

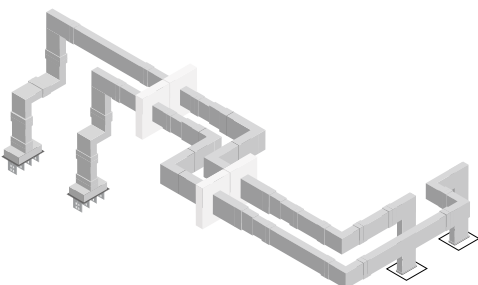

Rated service current	Rated insulation voltage	Color	Line components	
Inc	Ui		Length of components	Number of conductors

## Lighting and low power distribution from 25 to 40 A - IP55

Canalis KBA				
25 A	690 V	Pre-lacquered white (RAL9003)	2 m and 3 m	2 or 4 + PE
40 A				
Canalis KBB				
25 A	690 V	Pre-lacquered white (RAL9003)	2 m and 3 m	Single circuit 2 or 4 + PE Dual circuit 2 + 2 + PE 2 + 4 + PE 4 + 4 + PE
40 A				

## Power distribution from 40 to 160 A - IP55

Canalis KN *				
40 A	500 V	Pre-lacquered white (RAL9001)	2 m and 3 m	3L + N + PE
63 A				
100 A				
160 A				

\* Canalis KN range is available on se.com

## Horizontal and vertical distribution from 100 to 1000 A - IP55

Canalis KS *					
<b>Aluminium:</b> 100 A, 160 A, 250 A, 400 A, 500 A, 630 A, 800 A, 1000 A	<b>Copper:</b> 160 A, 250 A, 400 A, 630 A, 800 A	690 V	Pre-lacquered white (RAL9001)	3 m, 5 m and additional or customized components	3P + N + PE

\* Canalis KS range is available on se.com or catalogue: DEBU026EN

## Horizontal open track distribution from 250 to 630 A - IP42

I-Line Track				
250 A, 400 A, 630 A	1000 V <sup>(1)</sup>	Pre-lacquered white (RAL9003)	Standard 3 m or customized	3L + N + PE

(1) Insulation voltage of the run components. To be limited to the insulation voltage of devices used in tap-off units.

## Power transmission and distribution from 800 to 6300 A - IP55

Canalis KT *					
<b>Aluminium:</b> 800 A, 1000 A, 1250 A, 1600 A, 2000 A, 2500 A, 3200 A, 4000 A, 5000 A	<b>Copper:</b> 1000 A, 1350 A, 1600 A, 2000 A, 2500 A, 3200 A, 4000 A, 5000 A, 6300 A	1000 V	Pre-lacquered white (RAL9001)	2 m and 4 m	3L + PE 3L + N + PE 3L + N + PER

\* Canalis KT range is available on se.com or catalogue: KTA: ref. DEBU021EN / KTC: ref. DEBU024EN

## Power transmission for outdoor and harsh environment from 800 to 6300 A - IP68

Canalis KR *				
800 A, 1000 A, 1250 A, 1350 A, 1600 A, 2000 A, 2500 A, 3200 A, 4000 A, 5000 A, 6300 A	1000 V	Gray (RAL7030)	Up to 3 m	3L 3L + N or 3L + PE or 3L + PEN 3L + N + PE

\* Canalis KR range is available on se.com or catalogue ref. DEBU031EN

Branching points			Accessories		
Center to center distance		Protection type			
0.5 m, 1 m on 1 side	L + N + PE or 3L + N + PE (10/16 A) pre-cabled or to be cabled, with phase selection or fixed polarity, with lighting control	With fuses or without protection	> Flexible components > Fixing devices with quick adjustment > Communication bus (DALI, KNX, ASI) > Cable ducts	A	
0.5 m or 1 m on 1 or 2 sides	L + N + PE or 3L + N + PE (10/16 A) pre-cabled or to be cabled, with phase selection or fixed polarity, with lighting control	With fuses or without protection	> Flexible components > Fixing devices with quick adjustment > Communication bus (DALI, KNX, ASI) > Cable ducts		B
0.5 m, 1 m on 1 side	16 A to 63 A (plug-in)	Units for modular circuit breakers, fuses and sockets	> Flexible components > Fixing devices with quick adjustment > Remote control bus > Cable ducts > Installation accessories		C
0.5 m or 1 m on each side for horizontal version, and on one side for vertical version	16 A to 400 A (plug-in)	Units for circuit breakers (modular, Compact NSX), fuses, sockets	> Riser ducting offer > Fixing devices with quick adjustment > Cable ducts > Installation accessories > Fire barriers		D
Continuous opened channel	16 A to 63 A outputs in tap-off units		> Data Center IT room > Fixing devices with quick adjustment > Installation accessories > Color customization		E
0.5 m or 1 m	80 A to 630 A (plug-in) 400 A to 1250 A (bolt-on)	Units for circuit breakers (modular, Compact NSX), fuses, sockets	> Power supply ends > Direction change angles and T-pieces > Fixing devices and fuses		
-	-	-	> Power supply ends > Direction change angles and T-pieces > Fixing devices > Fire resistant elements		



# Introduction

---

I-Line Track .....	A-2
Tools and services .....	A-6



# I-Line Track:

Information technology undergoes constant change.

What will future servers be like?

What technical, environmental and economic constraints will determine their maximum capacity within safe operating limits?

All these questions are hard to answer, but they influence your decisions today.

## How can you plan ahead for these changes?

I-Line Track is a power distribution system for server racks, meeting your requirements for electrical power availability, energy savings and return on investment, while still allowing you to flexibly adapt to changing needs.

I-Line Track helps improve the continuity of service in your data center, optimize site energy efficiency, and reduce the long-term impact on the environment by reducing cabling and the waste generated during traditional retrofits.

This flexible, scalable and sustainable solution lets you invest for today's needs while preparing for tomorrow's possibilities.



### Under control installation

The power supply is fully controlled, thanks to integrated connected products and a proven design.



### Upgradeable and scalable

The open track design provides great flexibility for both first time installations and upgrades.

Add or relocate tap-off units easily with the smart clamping system.



### Tools and services

With advanced software and tools, we help you accelerate the whole lifecycle of your project.

Our teams are available to provide technical assistance to work together on your installation.

# Data Center Architecture

I-Line Track is part of the comprehensive Schneider Electric offer for data centers

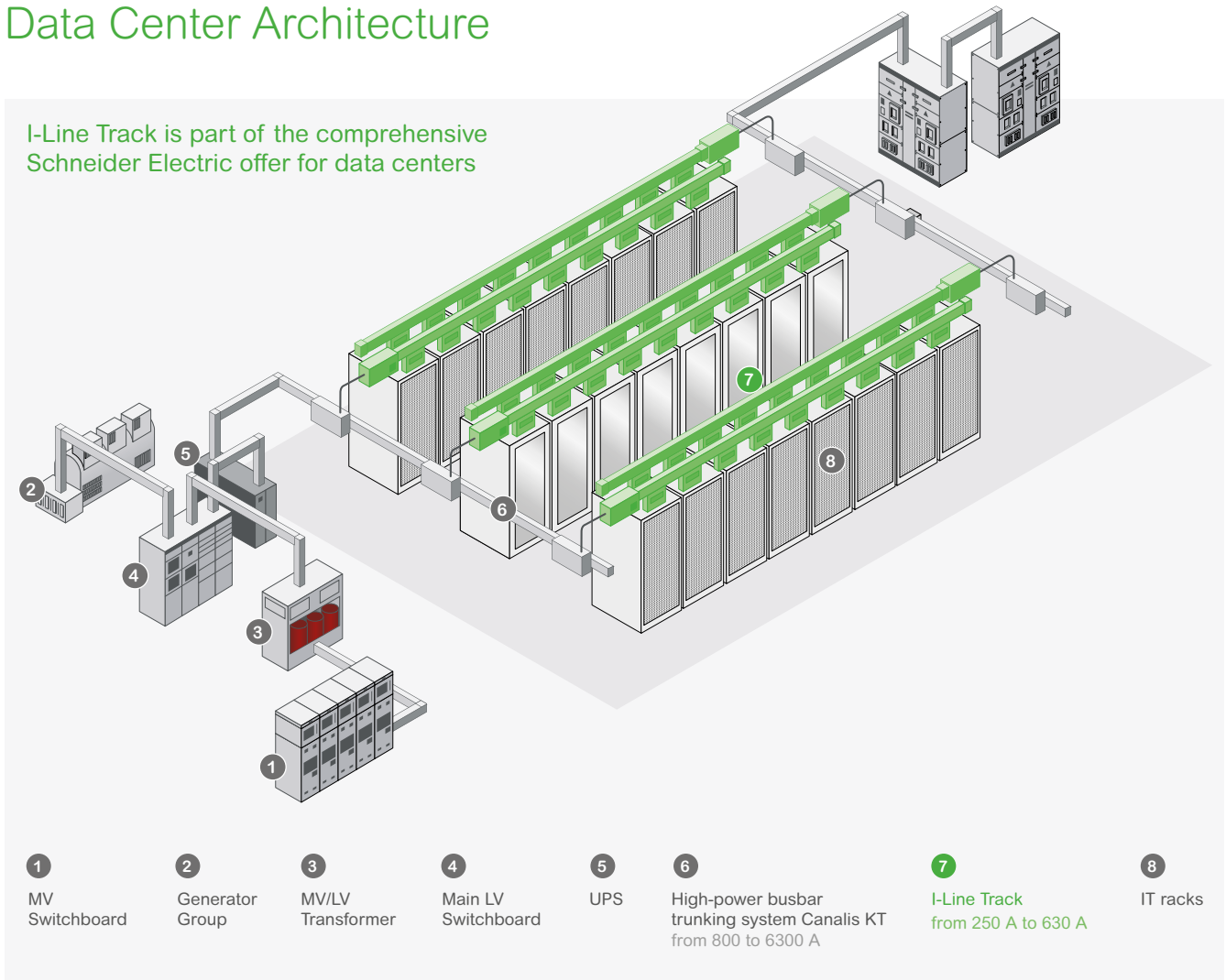

A

B

C

D

E

## EcoStruxure™ Innovation At Every Level

### Connected ready



- Tripping alarm
- Overload alarm
- Capacity management and energy management



A dedicated channel provides a simple and aesthetic communication cable storage

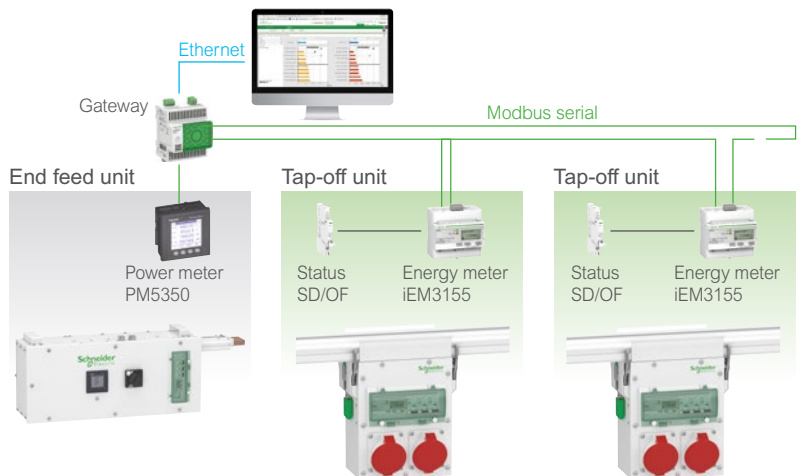

# I-Line Track: flexible, reliable and connected busbar trunking system

A

B

C

D

E

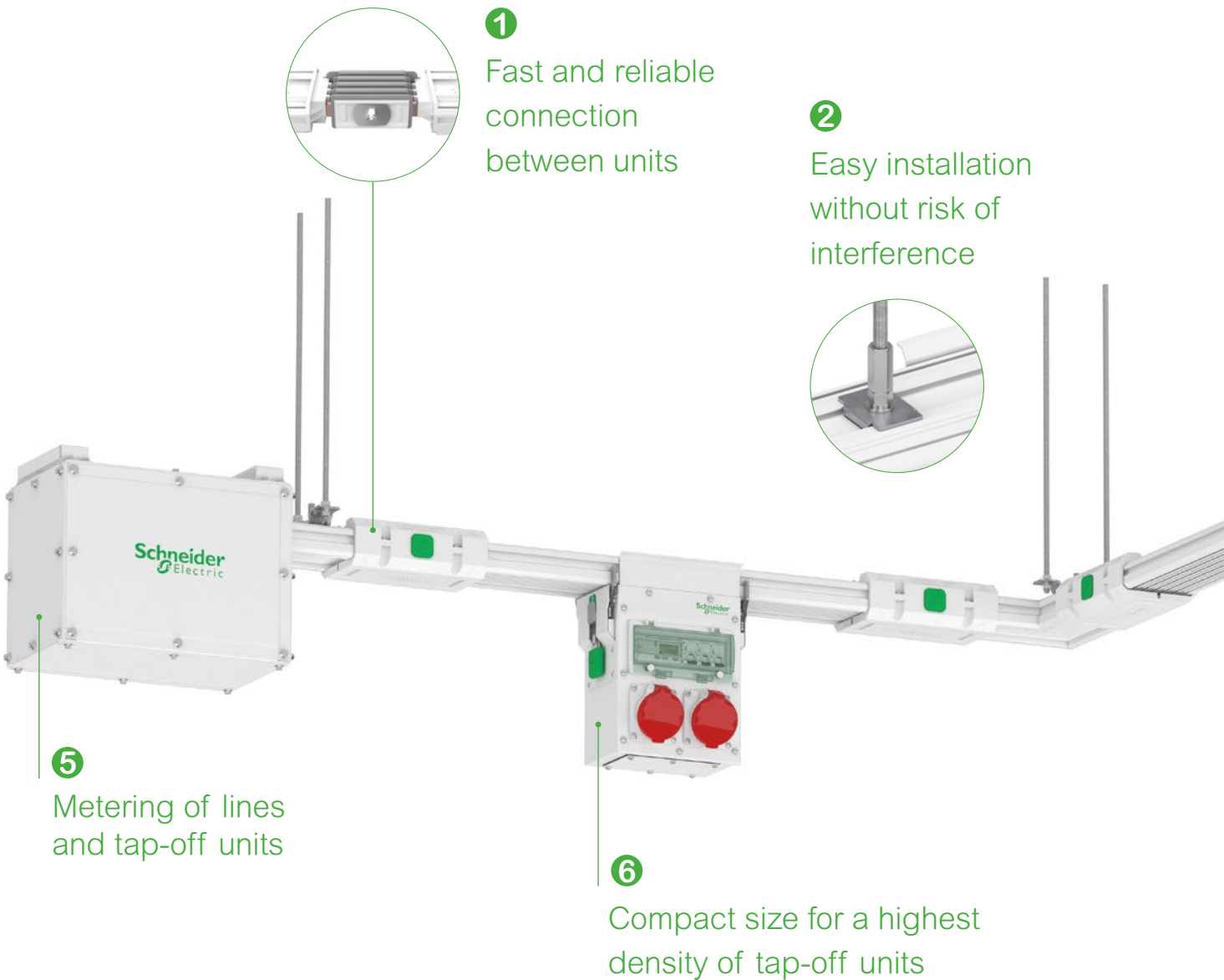

**1**  
Fast and reliable  
connection  
between units

**2**  
Easy installation  
without risk of  
interference

**5**  
Metering of lines  
and tap-off units

**6**  
Compact size for a highest  
density of tap-off units

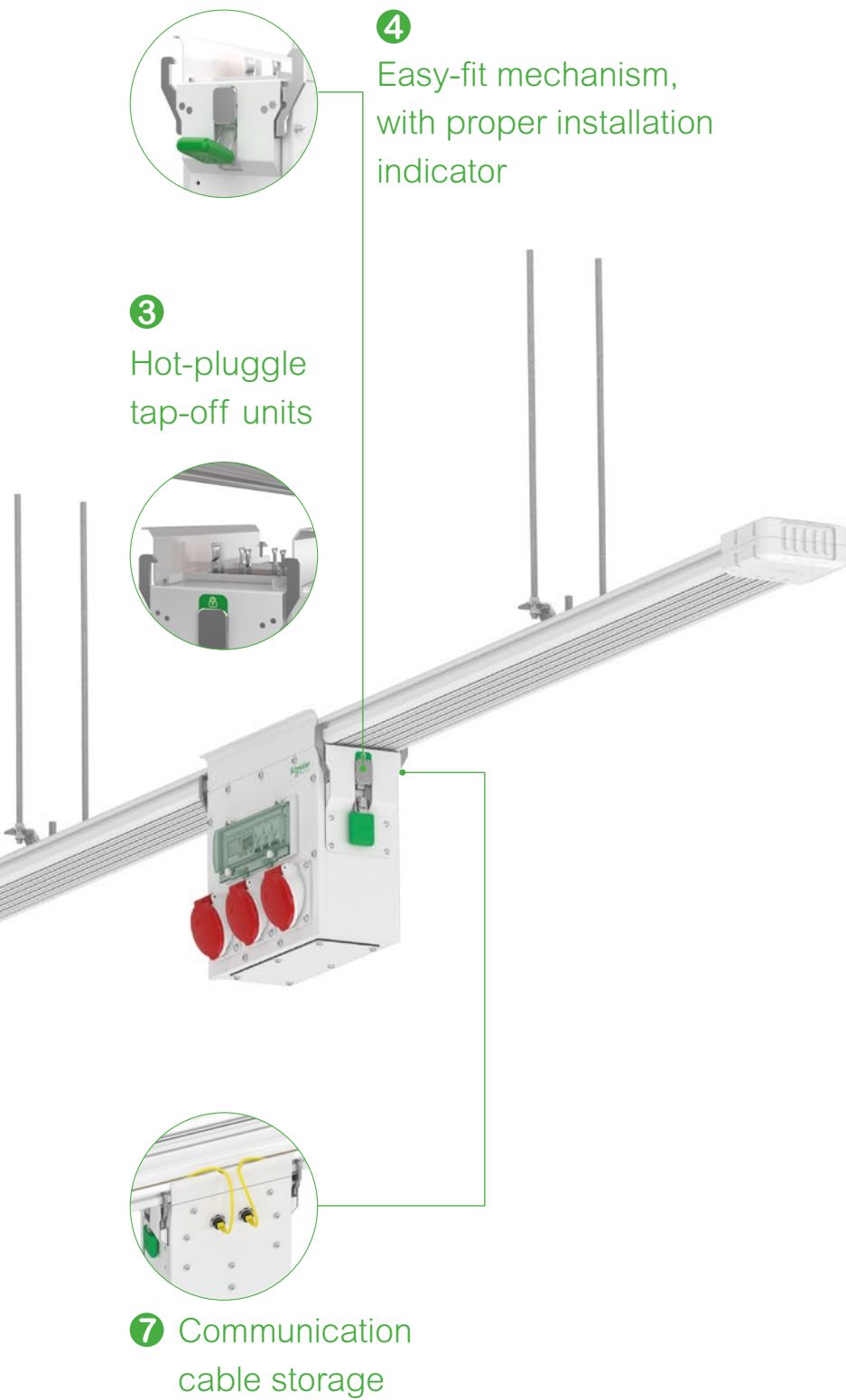

**4** Easy-fit mechanism, with proper installation indicator

**3** Hot-pluggable tap-off units

**7** Communication cable storage

**1**

- Single bolt connection
- Simultaneous connection of all conductors
- Snap-off head bolt to guarantee a proper tightening

**2**

- Quarter-turn system
- Positioning by sliding along the length
- No interference with tap-off units
- For threaded rods or C profile

**3**

- Connecting jaws made of silver-plated spring copper
- Up to 128 A

**4**

- Easy installation and locking.
- No special tools neither tightening bolts
- Green lock indicator

**5**

- Tripping alarm
- Overload alarm
- Capacity management
- Energy consumption

**6**

- Very compact (240 mm)
- Up to 6 tap-off units per 3 meter length
- Plugged on the bottom
- For panel or wander sockets up to 63 A
- IP42

**7**

- Modbus communication
- Daisy chain
- Cable storage slot

A

B

C

D

E

A

### Quotation and Design tools

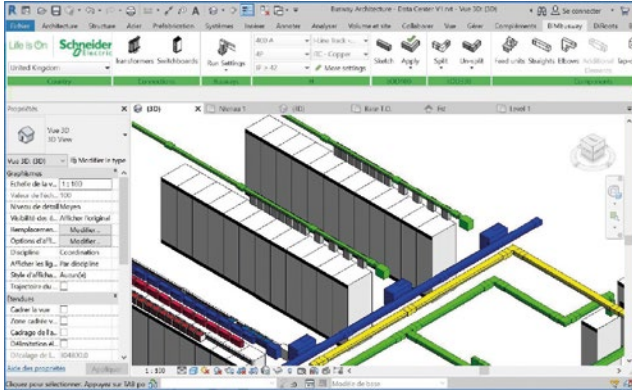

B

C

D

E

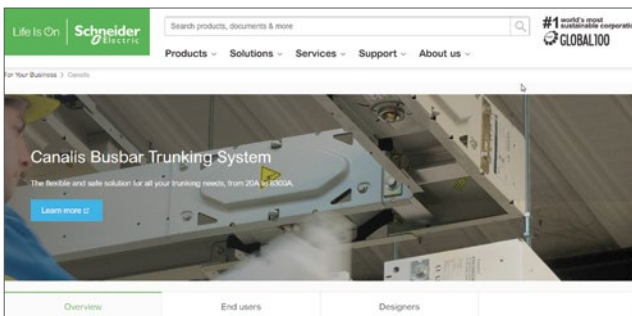

#### Cantools

> 3 software options enabling design and quotation of power distribution branches made of Canalis

#### CanCad

> is a Plug-in for Autocad. It allows to easily design and get bill of materials.

#### BIMBusway

> is a Plug-in for Revit. It allows to easily design and get bill of materials in BIM format.



> Youtube



... about Canalis and I-Line ranges

# Selection Guide and Description

Example of architecture ..... B-2  
Metering at rack and line level ..... B-2  
Communication solutions ..... B-3

Selection of modular tap-off units..... B-4  
Circuit breakers, auxiliaries and communication devices ..... B-4

Line components ..... B-5  
Straight lengths and change directions ..... B-5  
End feed units..... B-6

Fixations and supports ..... B-7

Tap-off units ..... B-8  
Socket configurations ..... B-9

Selection of modular tap-off units.....B-10  
Number of DIN rail mounted device modules ..... B-10  
Sockets types and cut-out sizes ..... B-11



## Selection Guide

# Example of architecture

## Metering at rack and line level

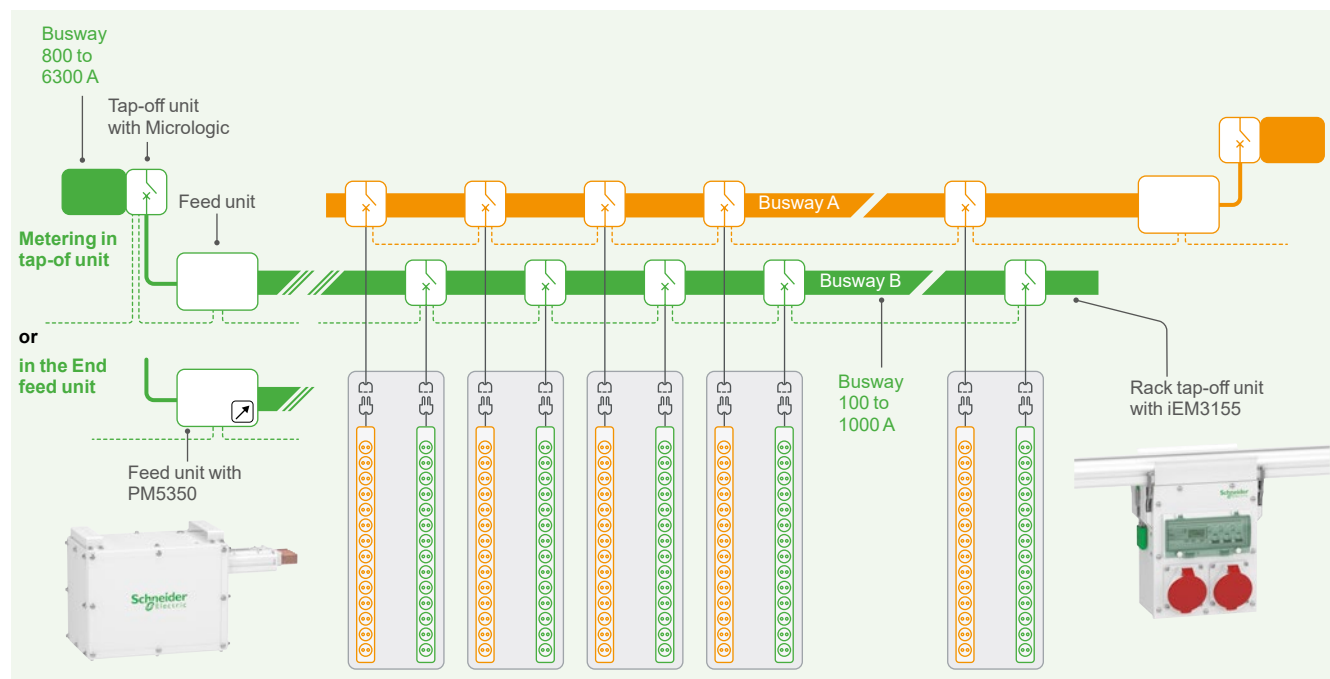

✓  
The rack tap-off units are equipped with iEM3155 energy meters.

✓  
The load monitoring at the line level is achieved with Micrologic 5.0 E trip unit of Compact NSX in the I-Line Track protection units.

✓  
This wired architecture enables local display at the rack level. It also gives access to advanced monitoring features at the line level thanks to the Micrologic trip unit.

## Functions

- The energy meter provides information on voltage, current, power, energy, etc. Class 1 and class 0.5S accuracy for active energy.
- Compliance to MID regulation which enables sub-billing.
- Multi-tariff selection by digital inputs or internal clock.
- Graphical display for easier viewing.

## Technical characteristics



A9MEM3155

### Main characteristics

Control power	Self-powered meters
Voltage measurement	50 to 330 V (Ph-N) 80 to 570 V (Ph-Ph) Up to 1 MV AC (ext VT)
Current	Direct measurement up to 63 A without CTs
Accuracy	Class 1
Width	Compact, 5 modules
Communication	Modbus
Standards	Compliance with IEC 61557-12, IEC 62053-21/22, IEC 6253-23, EN50470-3
Value measurement	Active energy, reactive energy, active power, Reactive power, currents and voltages, overload alarm
MID compliant (selected models) providing certified accuracy and data security	
Catalog numbers	<b>A9MEM3155</b>

### Selection table for metering at the Rack level

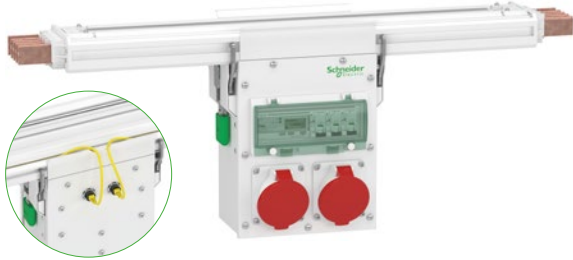

Wired  
iEM3155

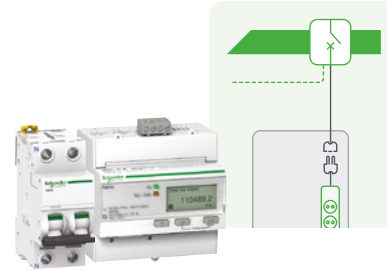

Energy metering	Yes
MID compliance	Yes
Current, voltage metering	Yes
THD/TDD metering	Yes
Local Display	Yes
Tripping information SD	Yes
Status information OF	No
Tripping analysis	No
Gateway	PAS600
Communication to gateway	Modbus RS485
Communication protocol with	Modbus TCP/IP
Scalability without	No

### Selection table for metering at the Line level

	Wireless	Wired	
	PowerTag NSX	PM5350	Micrologic 5.0 E

Energy metering	Yes	Yes	Yes
MID compliance	No	Yes	No
Current, voltage metering	Yes	Yes	Yes
Tripping information (OF/SD)	Yes with PowerTag C I/O	No	Yes
Tripping analysis	No	No	Yes
THD/TDD metering	No	Yes	Yes
Local Display	No	Yes	Yes
Gateway	PowerTag Link	PAS600	PAS600
Communication to gateway	Wireless Zigbee	Modbus TCP/IP	Modbus TCP/IP or RS485
Communication to upper system	Modbus TCP/IP	Modbus TCP/IP	Modbus TCP/IP

# Selection of modular tap-off units

## Circuit breakers, auxiliaries and communication devices



### Acti9 iC60 circuit-breaker, C and D curves

Circuit overcurrent protection and control (general applications).  
The magnetic releases act between 5 and 10  $I_n$  in C curve and between 10 and 20  $I_n$  in D curve.



### A SI type Acti9 Vigi iC60 residual current module

Ideally suited for operation in environments with:

- High nuisance tripping risks: lightning strokes at close intervals, IT earthing system, presence of electronic ballasts, presence of switchgear incorporating interference suppression filters of the lighting, micro-computing type, etc.
- Blinding sources:
  - presence of harmonics or rejection of high frequencies,
  - presence of DC components: diodes, diode bridges, switch mode power supplies, etc.

Its use depends on applicable legislation in your country.



### Auxiliary contact

The auxiliary contacts allow remote indication of circuit-breaker status.

- iSD auxiliary contact: indicates tripping on circuit-breaker fault.
- iOF auxiliary contact: indicates circuit-breaker open or closed position.

A test button on the front face of the auxiliary contacts simulates faults without needing to use the circuit-breaker.



### iEM3155 energy meter

The energy meter provide information on voltage, current, power, energy, etc.  
This information is transmitted to the Management System via Modbus TCP communication through a gateway.

A

B

C

D

E

# Line components

## Straight lengths and change directions

Straight lengths and change direction components are designed to carry the current and supply loads.

### Straight length

#### Type ST

I-Line Track is an open track distribution unit. The proposed ratings are 250, 400, and 630 A with copper conductors. The open track unit is designed to be installed with the connection grid on the bottom.

The open track units may be equipped with metallic or molded tap-off units.

All the insulating and plastic materials are halogen-free and have enhanced fire-withstand capabilities (incandescent wire test as per standard IEC 60695-2: 960 °C for components in contact with live parts and 650 °C for other components).

The degree of protection of the open track is **IP42** for indoor installations, thanks to a cover profile delivered with each straight length.

The basic structure of the line is made up of:



#### 1. Casing

The RAL 9003 painted extruded aluminium casing provides an excellent resistance to bending and twisting. Its shape is designed for an easy bracket fixation. Several other colors are optionnally available.

A slot in the aluminum profile allows the storage of the communication cable

#### 2. Conductors

The 4 active conductors are made of Electrolytic-Copper CU ETP 99.9% - bare copper.

#### 3. Protective conductor (PE)

Version PE = 50% CU, the protective earth conductor is made of copper CU ETP-99.9% and sized at minimum cross section of 50% of the actives conductors.

Version PE= AL enclosure, the protective earth conductor is made by the aluminium casing.

#### 4. Tap-off grid

Available on the bottom of the unit, it allows the installation of a high density of tap-off units at any position. A label indicates the front side to facilitate the correct installation of the tap-off units. The insulation profile is made of class B insulation material

#### 5. Mechanical and electrical jointing system

The junction between sections is made using a joint pack.

The joint pack provides the electrical connection between the live conductors, the protective conductors (PE), and the mechanical link between the two sections.

It provides a simultaneous connection of all conductors.

Its snap-off head of the tightening screw breaks when the proper torque is reached.

The presence of a green cap on the mechanical covers indicates the snap-off head has been broken.

The joint pack is not included in the unit reference and needs to be ordered separatly.



### Changing direction

#### Type EI/EO

Used for simple change direction (turn right or left). The degree of protection of the busbar trunking is IP42 for indoor installations.



## Description

# Line components

## End feed units

A

Used to feed the open track by cables. They can be mounted at the end of a line (end feed, left or right).



B

### Cable box feed unit

#### Type BI/BO

The end feed unit is used to connect by cables the open track line to the upstream network.

It can be mounted on either side of a straight. Version BI for the right extremities and BO for the left extremities.

C

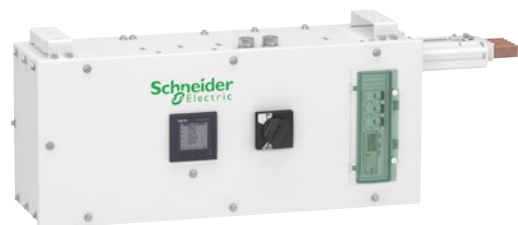

### Cable box feed unit with breaker and meter

#### Type BIN/BON

It can be mounted on either side of a straight. Version BIN for the right extremities and BON for the left extremities.

This version is equipped with a circuit breaker NSX250, NSX400, or NS630b and with a power meter to supervise the line up to the rack.

D



### End closure

#### Type CI/CO

The end cover protects and isolates the ends of the conductors. It is mounted on the last component. Version CI for the right extremities and CO for the left extremities. The end closure is not included in the end feed units reference and needs to be ordered separately.

E



### Single rod hanger

#### Type FB01

This hanger can be installed everywhere, without the risk of interference with tap-off units. The recommended distance between supports is 1.5 m.

This solution is for M12 threaded rods (not supplied).

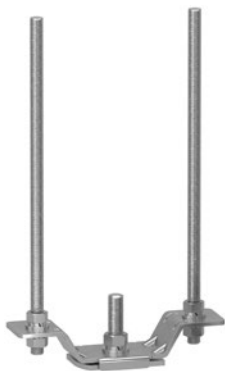
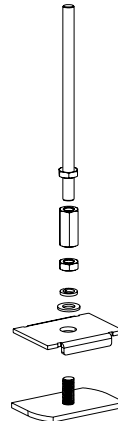

### Double rods hanger

#### Type FB02

This fixing bracket can be installed everywhere, without the risk of interference with tap-off units. The recommended distance between supports is 1.5 m.

This solution can be used with 2 M10 threaded rods or fixed on C profile supports.

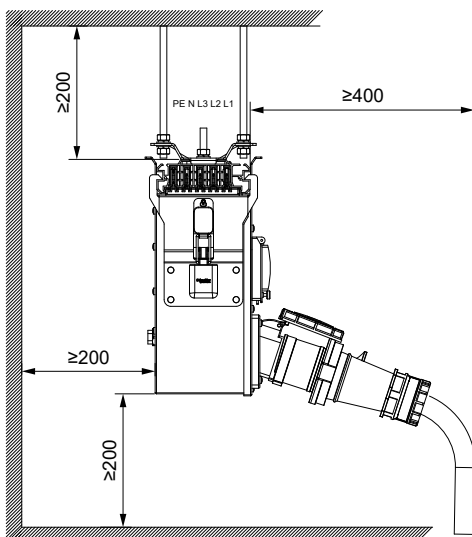
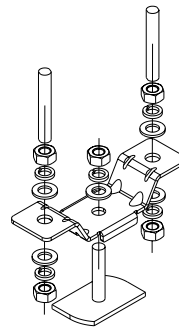

Front side

A

B

C

D

E

# Description

## Tap-off units

A



B



C



D



E

### Design

I-Line Track metallic tap-off units are made of aluminum sheet metal, epoxy painted RAL9003 for the standard version.

The connecting jaws are made of silver-plated spring copper.

### Installation

Tap-off units can be installed on the bottom of the open track at any location providing the maximum of flexibility.

They can be installed with the power on the line to avoid downtime when adding new racks.

Downstream loads must be disconnected prior plugging or unplugging the tap-off units into the line.

The protective earth (PE) connection is ensured prior to the active conductors.

Tap-off units are mechanically fitted to straight lengths thanks to an easy-fit mechanism. A green lock indicator indicates the proper installation. No special tools or tightening bolts are required to complete their installation.

The minimum distance between tap-off units is 180 mm. Up to 6 tap-off units (240 mm) can be plugged in a 3 meter length, 5 for large tap-off units (366 mm).

### Equipment

I-Line track metallic tap-off units are designed to allow maximum customization.

They can be equipped with wander or panel sockets, protected by Acti 9 breakers, and monitored by energy meters such as IEM3155.

Sockets can be installed in front or bottom.

Two sizes of tap-off units are available:

A narrow version (240 mm) can be equipped with three wander sockets or two panel sockets. Cut-out are ready for 90 x 100 panel sockets.

The total current allowed for this version is 63 A which means up to two sockets of 32 A or three sockets of 16 A (wander version) can be installed.

A 10 modules of 18 mm DIN rail and window are available for multi 9 circuit breakers and other devices.

A large version (366 mm) can be equipped with up to three panel sockets

The total current allowed for this version is 128 A which means up to two sockets of 63 A or three sockets of 32 A.

# Description

## Tap-off units

### Socket configurations

#### Panel sockets

<b>Width = 240 mm</b>	<b>Width = 366 mm</b>
<b>10 modules of 18 mm</b>	<b>12 modules of 18 mm</b>



#### Wander sockets

<b>Width = 240 mm</b>	<b>Width = 366 mm</b>
<b>10 modules of 18 mm</b>	<b>12 modules of 18 mm</b>

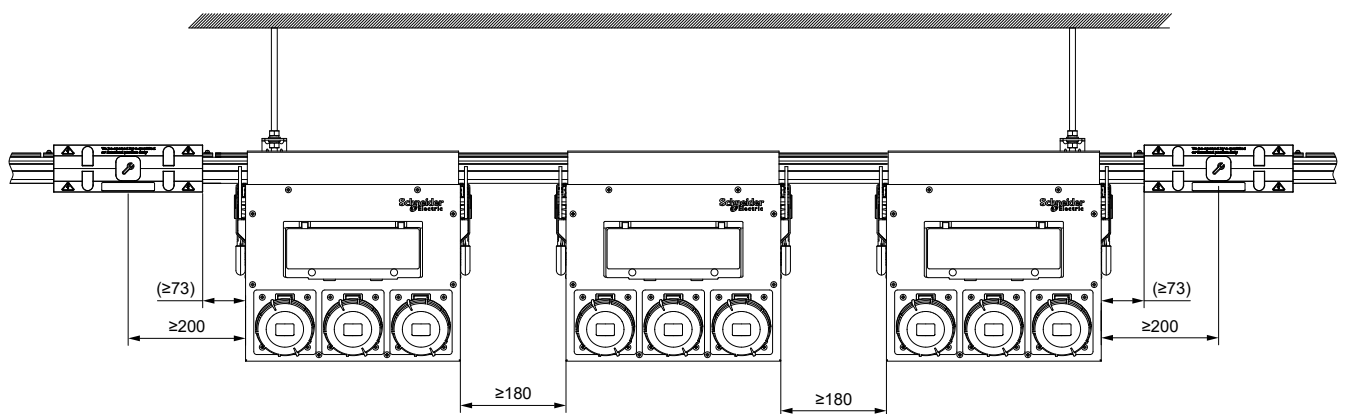

A

B

C

D

E

## Description

## Selection of modular tap-off units

## Number of DIN rail mounted device modules



## Neutral conductor not protected

Number of poles	Rating (A)	Number of sockets	Number of modules of 18 mm		
			MCB	MCB + SD	MCB + SD + iEM3155
P+N	16	1	1	1.5	6.5
		2	2	3.0	8.0
		3	3	4.5	9.5
		4	4	6.0	11.0
	32	1	1	1.5	6.5
		2	2	3.0	8.0
		3	3	4.5	9.5
		4	4	6.0	11.0
3P+N	16	1	3	3.5	8.5
		2	6	7.0	17.0
	32	1	3	3.5	8.5
		2	6	7.0	17.0
	63	1	3	3.5	8.5
		2	6	7.0	17.0

MCB = Miniature Circuit Breaker  
SD = Auxiliary contact  
iEM = Energy meter

## Neutral conductor protected

Number of poles	Rating (A)	Number of sockets	Number of modules of 18 mm						
			Without Vigì			With Vigì			
			MCB	MCB +SD	MCB + SD + iEM3155	MCB	MCB +SD	MCB + SD + iEM3155	
P+N	16	1	2	2.5	7.5	4	4.5	9.5	
		2	4	5.0	10.0	8	9.0	14.0	
		3	6	7.5	12.5	12	13.5	18.5	
		4	8	10.0	15.0	16	18.0	28.0	
	32	1	2	2.5	7.5	7.5	4	4.5	9.5
		2	4	5.0	10.0	10.0	8	9.0	14.0
		3	6	7.5	12.5	12.5	12	13.5	18.5
		4	8	10.0	15.0	15.0	16	18.0	28.0
3P+N	16	1	4	4.5	9.5	7	7.5	12.5	
		2	8	9.0	19.0	14	15.0	25.0	
		3	12	13.5	28.5	21	22.5	37.5	
	32	1	4	4.5	9.5	9.5	7.5	8.0	13.0
		2	8	9.0	19.0	15	16.0	26.0	
		3	12	13.5	28.5	23	24.0	39.0	
	63	1	4	4.5	9.5	9.5	7.5	8.0	13.0
		2	8	9.0	19.0	15	16.0	26.0	

MCB = Miniature Circuit Breaker  
SD = Auxiliary contact  
iEM = Energy meter

# Selection of modular tap-off units

## Sockets types and cut-out sizes

### Fast connected sockets - 16 A and 32 A



Rated current	Polarity	Rated voltage V AC	Wander sockets IP44	Angled panel mounted sockets IP44	Straight panel mounted sockets IP44	Cut-out dimensions
16 A	2P+PE	200-250	PKY16M423	PKY16F423	PKY16G423	65 x 85
	3P+PE	200-250	PKY16M424	PKY16F424	PKY16G424	66 x 85
	3P+N+PE	200-250	PKY16M425	PKY16F425	PKY16G425	90 x 100
	2P+PE	380-415	PKY16M433	PKY16F433	PKY16G433	65 x 85
	3P+PE	380-415	PKY16M434	PKY16F434	PKY16G434	66 x 85
	3P+N+PE	380-415	PKY16M435	PKY16F435	PKY16G435	90 x 100
32 A	2P+PE	200-250	PKY32M423	PKY32F423	PKY32G423	90 x 100
	3P+PE	200-250	PKY32M424	PKY32F424	PKY32G424	90 x 100
	3P+N+PE	200-250	PKY32M425	PKY32F425	PKY32G425	90 x 100
	2P+PE	380-415	PKY32M433	PKY32F433	PKY32G433	90 x 100
	3P+PE	380-415	PKY32M434	PKY32F434	PKY32G434	90 x 100
	3P+N+PE	380-415	PKY32M435	PKY32F435	PKY32G435	90 x 100

### Screw connected sockets - 63 A



Rated current	Polarity	Rated voltage V AC	Wander sockets IP67	Angled panel mounted sockets IP67	Straight panel mounted sockets IP67	Cut-Out dimensions
63 A	2P+PE	200-250	81478	81278	81678	100 x 107
	3P+PE	200-250	81479	81279	81679	100 x 107
	3P+N+PE	200-250	81480	81280	81680	100 x 107
	2P+PE	380-415				100 x 107
	3P+PE	380-415	81482	81282	81682	100 x 107
	3P+N+PE	380-415	81483	81283	81683	100 x 107

### Socket blanking plate - Screw fixing

	Type	Description	Dimensions	Code
	Screw fixing	Blank - marked for 1 socket 50 x 50	65 x 85	13135
		Blank - marked for 1 socket 65 x 65	90 x 100	13137
	Clip fixing	Intermediate - with opening 65 x 85	90 x 100	13136

A

B

C

D

E

# Catalogue Numbers and Dimensions

Line components .....	C-2
Straight lengths.....	C-2
Change directions .....	C-4
End feed units.....	C-5
End closures .....	C-7
Fixations and supports .....	C-8
Tap-off units .....	C-10
For wander or panel sockets.....	C-10
For panel sockets.....	C-11



# Line components

## Straight lengths

### ST - Open track distribution - IP42



Catalogue numbers in green are Made to Stock

Type	Length (L)	Catalogue number		
3L+N+PE (PE=50% CU)	(mm)	<b>250 A</b>	<b>400 A</b>	<b>630 A</b>
Fixed	3000	<b>ITSC250GS42ST3000E</b>	<b>ITSC400GS42ST3000E</b>	<b>ITSC630GS42ST3000E</b>
	1200	<b>ITSC250GS42ST1200E</b>	<b>ITSC400GS42ST1200E</b>	<b>ITSC630GS42ST1200E</b>
Made to measure	600 to 1190 (1)	<b>ITSC250GS42STAE</b>	<b>ITSC400GS42STAE</b>	<b>ITSC630GS42STAE</b>
	1210 to 2990 (1)	<b>ITSC250GS42STBE</b>	<b>ITSC400GS42STBE</b>	<b>ITSC630GS42STBE</b>
3L+N+PE (PE=Enclosure)				
Fixed	3000	<b>ITSC250ES42ST3000E</b>	<b>ITSC400ES42ST3000E</b>	
	1200	<b>ITSC250ES42ST1200E</b>	<b>ITSC400ES42ST1200E</b>	
Made to measure	600 to 1190 (1)	<b>ITSC250ES42STAE</b>	<b>ITSC400ES42STAE</b>	
	1210 to 2990 (1)	<b>ITSC250ES42STBE</b>	<b>ITSC400ES42STBE</b>	

(1) Made to measure dimensions with 10 mm increment. To order, indicate for example: **ITSC250GS42STAE, L = 710**.

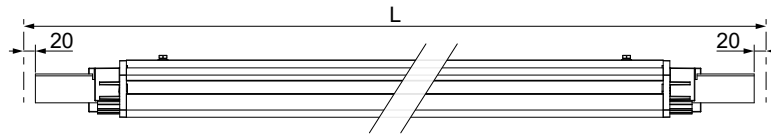

ITSC...GS•

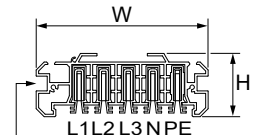

Front side

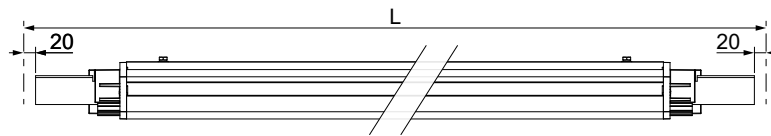

ITSC...ES•

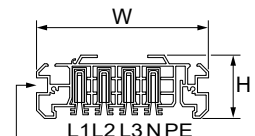

Front side

Rated current (A)	W	H	Weight (kg/m)	
	(mm)	(mm)	PE=50% CU	PE=Enclosure
250	140	51	7.9	7.2
400	140	51	9.2	8.5
630	140	58.5	14.1	13

# Catalogue numbers and Dimensions

## Line components

### Straight lengths

#### JK - Joint pack - IP42

Catalogue numbers in green are Made to Stock



Type	Catalogue number (1)		
3L+N+PE (PE=50% CU)	250 A	400 A	630 A
	ITSC250GS42JKE	ITSC400GS42JKE	ITSC630GS42JKE
3L+N+PE (PE=Enclosure)	ITSC250ES42JKE	ITSC400ES42JKE	

(1) It is mandatory to have the same rating between joint packs and run components, mixing is not possible

Rated current (A)	L (mm)	W (mm)	H (mm)	Weight (kg)	
				PE=50% CU	PE=Enclosure
250	254	157	80	2.5	2.5
400	254	157	80	2.9	2.9
630	254	157	86	3.3	3.3

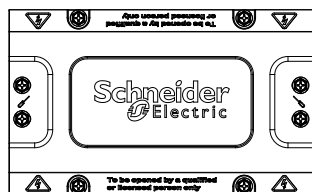
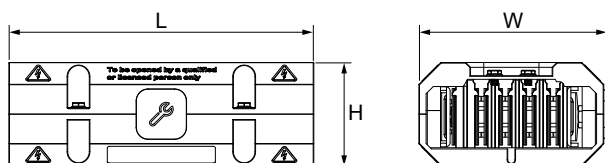

A

B

C

D

E

# Line components

## Change directions

**EI/EO - Elbow - Turn right or left - IP42**

A



Type	Catalogue number		
	250 A	400 A	630 A
3L+N+PE (PE=50% CU)			
S and B fixed EI	ITSC250GS42EIE	ITSC400GS42EIE	ITSC630GS42EIE
EO	ITSC250GS42EOE	ITSC400GS42EOE	ITSC630GS42EOE
3L+N+PE (PE=Enclosure)			
A and B fixed EI	ITSC250ES42EIE	ITSC400ES42EIE	
EO	ITSC250ES42EOE	ITSC400ES42EOE	

B



Rated current (A)	A	B	H	Weight (kg/m)	
	(mm)	(mm)	(mm)	PE=50% CU	PE=Enclosure
250	280	280	51.5	7.2	7.9
400	280	280	51.5	8.5	9.2
630	280	280	58.5	13	14.1

C

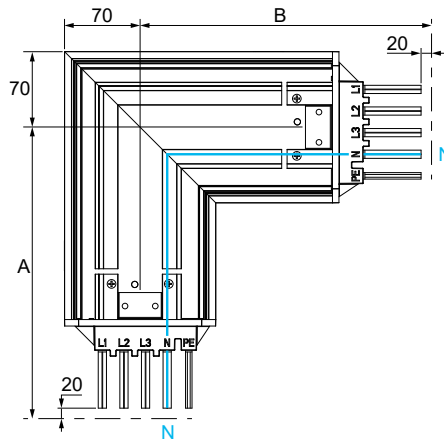

D

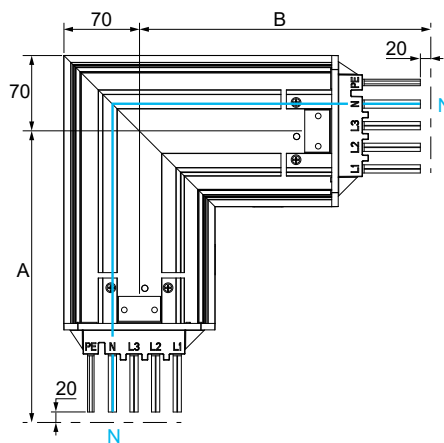

E

**BI/BO - Cable box feed unit - Right or left mounting - IP42**



Catalogue numbers in green are Made to Stock

Type	Catalogue number		
3L+N+PE (PE=50% CU)	250 A	400 A	630 A
Right mounting BI	ITSC250GS42BI0500E	ITSC400GS42BI0500E	ITSC630GS42BI0500E
Left mounting BO	ITSC250GS42BO0500E	ITSC400GS42BO0500E	ITSC630GS42BO0500E
3L+N+PE (PE=Enclosure)	250 A	400 A	630 A
Right mounting BI	ITSC250ES42BI0500E	ITSC400ES42BI0500E	
Left mounting BO	ITSC250ES42BO0500E	ITSC400ES42BO0500E	

Rated current	L	W	H	X	Y	A	B	C	Weight (kg/m)	
(A)	(mm)	(mm)	(mm)	(mm)	(mm)	(mm)	(mm)	(mm)	PE=50% CU	PE=Enclosure
250	608.5	235	325	353	267	24	51.5	214.5	13	13
400	608.5	235	325	353	267	24	51.5	214.5	13.5	13.5
630	688.5	255	355	433	267	45	58.5	216.5	16	16

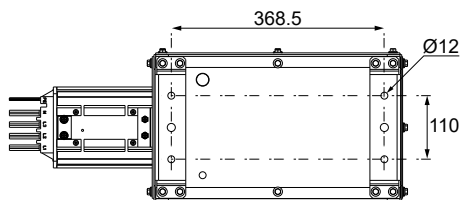
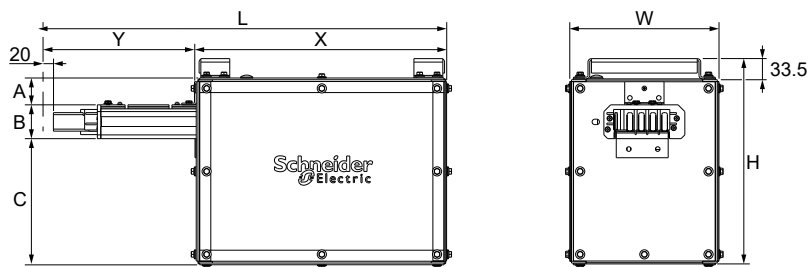

ITSC...GS42BI0500E / ITSC...ES42BI0500E

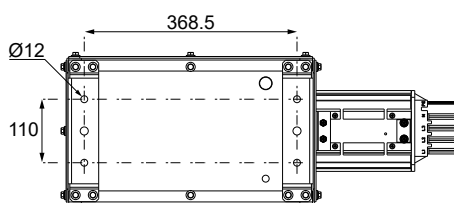
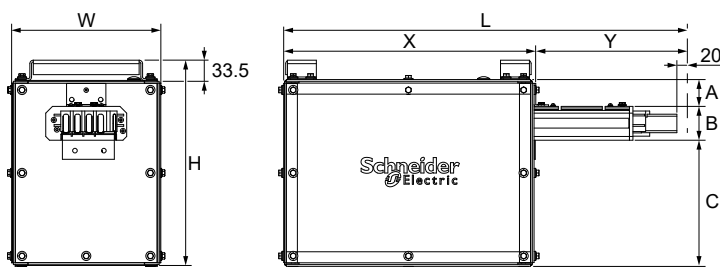

ITSC...GS42BO0500E / ITSC...ES42BO0500E

# Line components

## End feed units

**BI/BO - Cable box feed unit with breaker and meter - Right or left mounting - IP42**



Type	Breaking capacity	Catalogue number		
3L+N+PE (PE=50% CU)	50 kA	<b>250 A</b>	<b>400 A</b>	<b>630 A</b>
Right mounting BI		ITSC250GS42BINNM1E	ITSC400GS42BINNM1E	ITSC630GS42BINNM1E
Left mounting BO		ITSC250GS42BONNM1E	ITSC400GS42BONNM1E	ITSC630GS42BONNM1E
3L+N+PE (PE=Enclosure)	50 kA	<b>250 A</b>	<b>400 A</b>	<b>630 A</b>
Right mounting BI		ITSC250ES42BINNM1E	ITSC400ES42BINNM1E	
Left mounting BO		ITSC250ES42BONNM1E	ITSC400ES42BONNM1E	

Delivered with breakers NSX250N, NSX400N or NS630bN, one power meter.

Type				
Circuit breaker	NSX250N 50 kA 3P3D 250 A - TMD Ref: C25N3TM250	NSX400N 50 kA 3P3D 400 A - MicroLogic 2.3 Ref: C40N32D400	NS630bN 3P3D 630 A - MicroLogic 2.0 Ref: NS33460C	
Power meter	PM5350P Ref: METSEPM5350P	PM5350P Ref: METSEPM5350P	PM5350P Ref: METSEPM5350P	

Rated current (A)	L (mm)	W (mm)	H (mm)	X (mm)	Y (mm)	A (mm)	B (mm)	C (mm)	Weight (kg/m)	
									PE=50% CU	PE=Enclosure
250	940	235.5	370	680	260	29	51.5	259.5	25	25
400	1063	235.5	370	800	260	29	51.5	259.5	30	30
630	1182	260.5	460	918.5	260	28	58.5	343.5	52	52

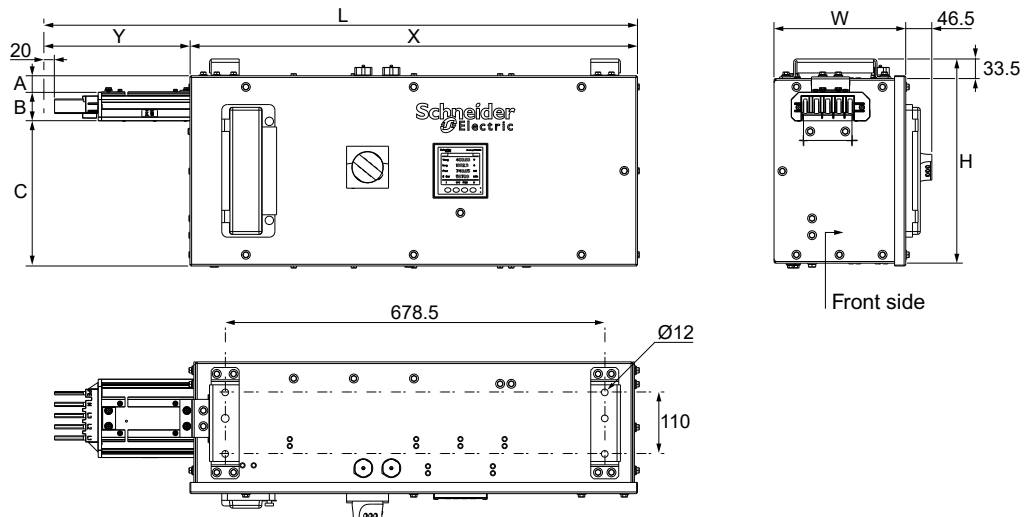

ITSC...GS42BINNM1E / ITSC...ES42BINMIE

# Catalogue numbers and Dimensions

## Line components

### End closures

#### BI/BO - Cable box feed unit with breaker and meter - Right or left mounting - IP42 (cont.)

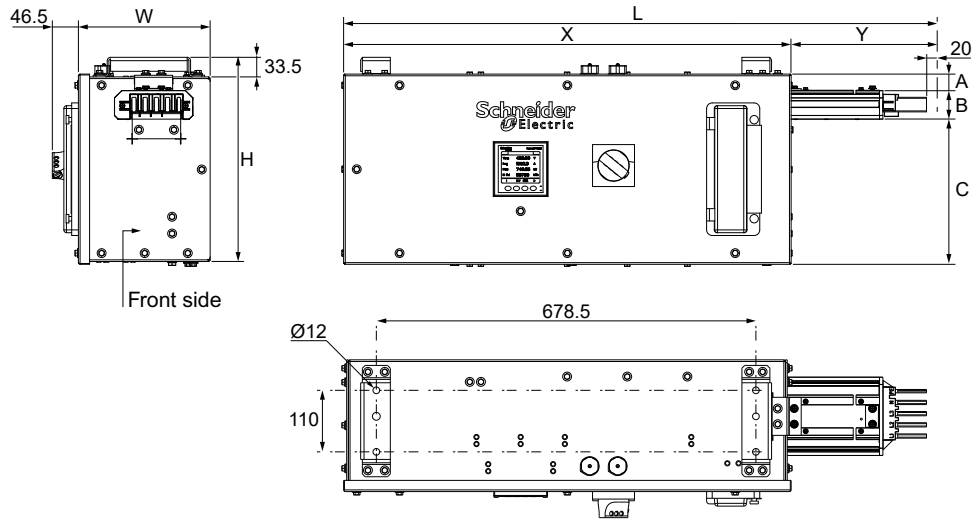

ITSC••GS42BONNM1E / ITSC••ES42BONNM1E

#### CI/CO - End closure- IP42

Catalogue numbers in green are Made to Stock



	Type	Catalogue number		
		250 A	400 A	630 A
Right mounting	CI	▶	ITSC400GS42CIE	ITSC630GS42CIE
Left mounting	CO	▶	ITSC400GS42COE	ITSC630GS42COE

Rated current (A)	L (mm)	W (mm)	H (mm)	Weight (kg)
250	125	154	60.5	0.5
400	125	154	60.5	0.5
630	125	154	67.5	0.5

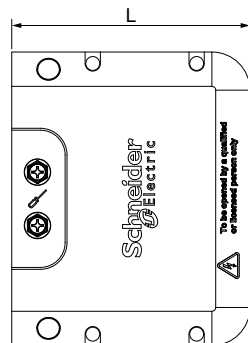

ITSC••GS42CIE

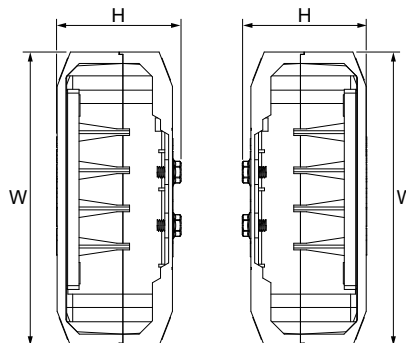

ITSC••GS42COE

▶ No dedicated reference for this rating. Select the first above available reference.

### FB01 - Single rod hanger

Catalogue numbers in green are Made to Stock



Type	Description	Catalogue number
Single rod hanger	Hanger for M12 threaded rod	<b>ITSC630GS42FB01</b>

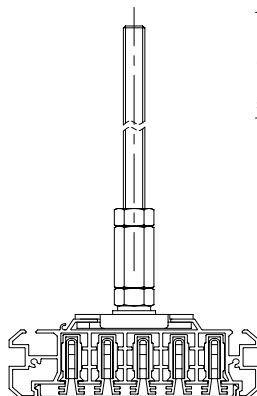
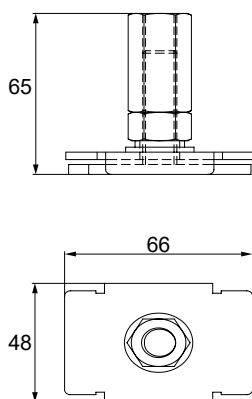

Drop rods not supplied, M12 is suggested

Screw nuts not provided, M12 screw nuts are suggested

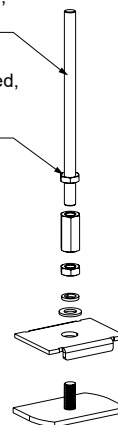

### FB02 - Double rod hanger

Catalogue numbers in green are Made to Stock



Type	Description	Catalogue number
Double rod hanger	Hanger for 2 M10 screws or threaded rods	<b>ITSC630GS42FB02</b>

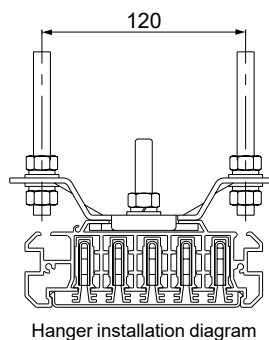
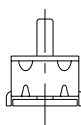
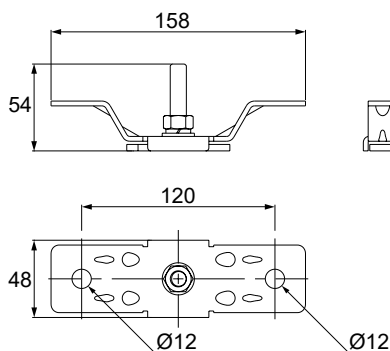

Hanger installation diagram

Drop rod, screw nut and gasket not provided, 10 mm

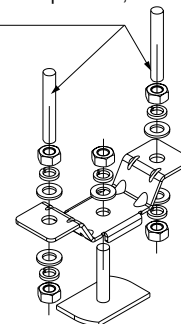

A

B

C

D

E

# Tap-off units

For wander or panel sockets

**A9 - Tap-off unit - 3L+N+PE - for wander or panel sockets 16 A or 32 A with cut-out 90x100**

Catalogue numbers in green are Made to Stock

A



ITSM000E42EB1E

Tap-off unit polarity	Tap-off unit rating (A)	Type	Width W (mm)	Nb of module of 18 mm	Sockets rating	Nb of wander sockets (3)	Nb of panel sockets (3)	Catalogue number
3L + N + PE	63	Narrow T1	240	10	2x16 or 32 A	1 to 3	1 to 2	ITSM000E42EB1E
L1 L2 L3 N PE	63	Large T2	366	12	3x16 or 32 A	1 to 3	1 to 3	ITSM000E42EB2E
DB411149	128	Large T3	366	12	2x63 A	1 to 3	1 to 2	ITSM000E42EB3E

B

- (1) Delivered with two blank front plates and one bottom pass-through plate
- (2) For sockets 16 A with cut-out 65X85, intermediate plates ref:13136 need to be added
- (3) The possible of number sockets needs to be checked in the configuration table (page B-10)

C



ITSM000E42EB2E

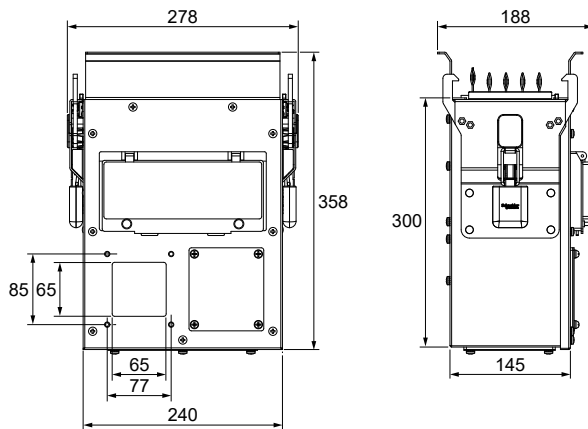

D



ITSM000E42EB3E

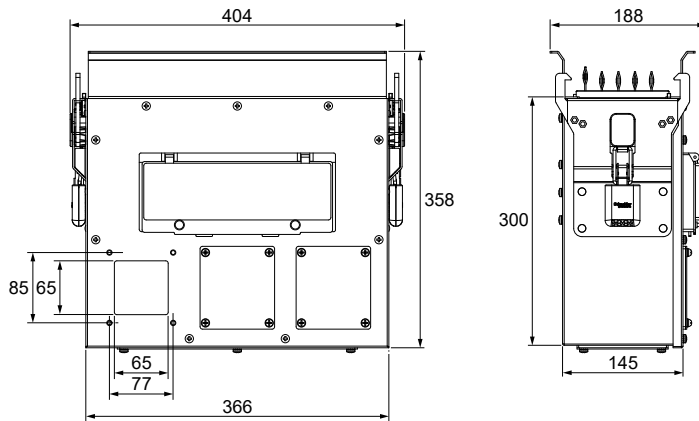

E

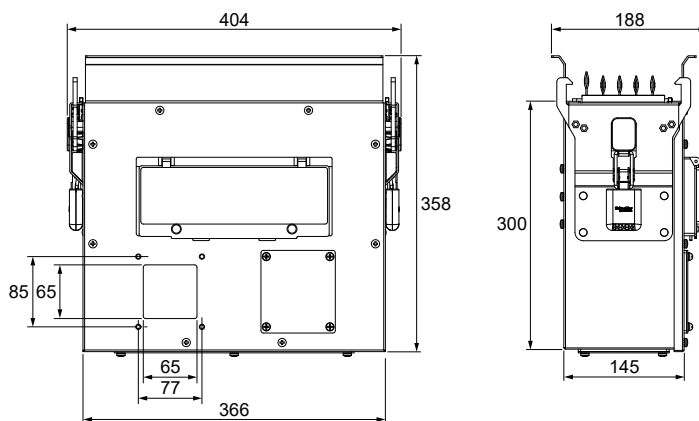

# Catalogue numbers and Dimensions

## Tap-off units

### For panel sockets

**FP - Front plate - for panel sockets 63 A with cut-out 100x107**

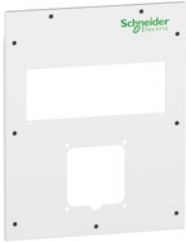

ITSM000FP421E

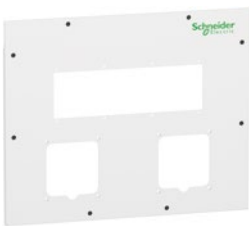

ITSM000FP422E

Type	Width	Nb of module of 18 mm	Sockets rating	Nb of panel sockets	Catalogue number
	W (mm)				
Narrow T1	240	10	63 A	1	ITSM000FP421E
Large T2	366	12	63 A	2	ITSM000FP422E

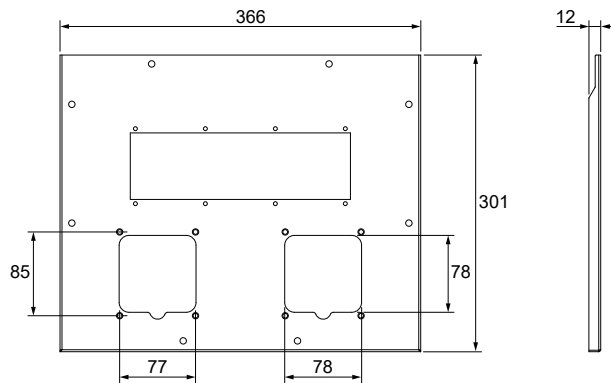
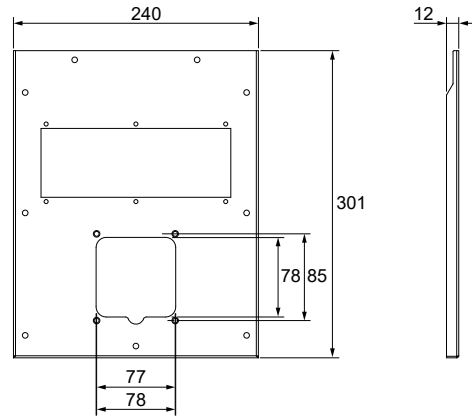

A

B

C

D

E

# Characteristics

I-Line Track - Line components.....	D-2
Electrical characteristics.....	D-2
I-Line Track - Tap-off units .....	D-3
Electrical characteristics.....	D-3
Coordination .....	D-4
Characteristics and recommendations .....	D-4

# Characteristics

## I-Line Track - Line components

### Electrical characteristics

Rating of trunking (A)				250	400	630		
<b>General characteristics</b>								
Compliance with standards				IEC / EN 61439-6				
Degree of protection		IP	IP20/IP42					
Mechanical impacts				IK08				
Rated current at an ambient temperature of 35 °C		$I_nA$	<b>A</b>	250	400	630		
Rated operational voltage		$U_e$	<b>V</b>	1000				
Rated insulation voltage		$U_i$	<b>V</b>	1000				
Rated impulse voltage		$U_{imp}$	<b>V</b>	8				
Rated short-time withstand current (1 s)		$I_{cw}$	<b>kA</b>	10	17	31		
Rated peak withstand current		$I_{pk}$	<b>kA</b>	28	49	65		
Rated frequency		$f$	<b>Hz</b>	50/60				
<b>Conductor characteristics</b>								
<b>Phase conductors</b>								
Mean resistance at an ambient of 20 °C		$R_{20}$	<b>mΩ/m</b>	0.267	0.173	0.091		
Mean resistance at $I_{nc}$ and ambient of 35 °C		$R$	<b>mΩ/m</b>	0.314	0.218	0.116		
Mean reactance at $I_{nc}$ , and ambient of 35 °C		$X$	<b>mΩ/m</b>	0.082	0.075	0.061		
Mean impedance at $I_{nc}$ , and ambient of 35 °C		$Z$	<b>mΩ/m</b>	0.325	0.231	0.131		
<b>Protective conductor</b>								
Mean resistance at an ambient of 20 °C (PE=Enclosure)			<b>mΩ/m</b>	0.682	0.489	0.424		
Mean resistance at an ambient of 20 °C (PE = 50% CU)			<b>mΩ/m</b>	0.193	0.174	0.105		
<b>Fault loop characteristics</b>								
Symmetrical components method	Ph/N at 20 °C	Mean resistance	$R_{(0) b20 ph/N}$	<b>mΩ/m</b>	1.670	0.980	0.430	
		Mean reactance	$X_{(0) ph/N}$	<b>mΩ/m</b>	0.364	0.344	0.285	
		Mean impedance	$Z_{(0) b20 ph/N}$	<b>mΩ/m</b>	1.709	1.039	0.516	
	Ph/PE at 20 °C	Mean resistance	$R_{(0) b20 ph/PE}$	<b>mΩ/m</b>	0.682	0.489	0.424	
		Mean reactance	$X_{(0) ph/PE}$	<b>mΩ/m</b>	0.136	0.144	0.129	
		Mean impedance	$Z_{(0) b20 ph/N}$	<b>mΩ/m</b>	0.695	0.509	0.444	
Impedance method	At 20 °C	Mean resistance	Ph/Ph	$R_{b20 ph/ph}$	<b>mΩ/m</b>	0.540	0.345	0.191
			Ph/N	$R_{b20 ph/N}$	<b>mΩ/m</b>	0.556	0.361	0.202
			Ph/PE	$R_{b20 ph/PE}$	<b>mΩ/m</b>	0.373	0.261	0.194
	For $I_{nc}$ at 35 °C	Mean resistance	Ph/Ph	$R_{b ph/ph}$	<b>mΩ/m</b>	0.577	0.368	0.203
			Ph/N	$R_{b ph/N}$	<b>mΩ/m</b>	0.593	0.385	0.214
			Ph/PE	$R_{b ph/PE}$	<b>mΩ/m</b>	0.398	0.278	0.207
	For $I_{nc}$ at 35 °C and 50 Hz	Mean reactance	Ph/Ph	$X_{b ph/ph}$	<b>mΩ/m</b>	0.146	0.143	0.114
			Ph/N	$X_{b ph/N}$	<b>mΩ/m</b>	0.169	0.175	0.136
			Ph/PE	$X_{b ph/PE}$	<b>mΩ/m</b>	0.095	0.101	0.082
	<b>Voltage drop at an ambient temperature 35 °C (full load, load distribution factor = 1)</b>							
	Apower factor of		1	<b>V/100 m/A</b>	0.0544	0.0378	0.0200	
			0.9	<b>V/100 m/A</b>	0.0552	0.0397	0.0226	
		0.8	<b>V/100 m/A</b>	0.0521	0.0380	0.0224		
		0.7	<b>V/100 m/A</b>	0.0482	0.0357	0.0216		
<b>Ambient temperature</b>								
Coefficient		40 °C		1	1	1		
		45 °C		0.972	0.972	0.972		
		50 °C		0.943	0.943	0.943		
		55 °C		0.913	0.913	0.913		
		60 °C		0.882	0.882	0.882		

# Characteristics

## I-Line Track - Tap-off units

### Electrical characteristics

Metallic tap-off units			
Degree of protection	IP		42
Mechanical impacts	IK		08
Rated insulation voltage	$U_i$	<b>V</b>	400, 500 depending on protective device
Rated operational voltage	$U_e$	<b>V</b>	400, 500 depending on protective device
Rated impulse voltage	$U_{imp}$	<b>kV</b>	6.8
Rated frequency	f	<b>Hz</b>	50/60

A

B

C

D

E

# Coordination

## Characteristics and recommendations

The selection guides below can be used to determine the circuit breaker required to fully protect the trunking depending on the prospective short-circuit current of the installation. In bold, the most appropriate device to the rating of the busbar trunking.

A

### Selection guide for Ue: 380-415 V AC

B

#### Type of I-Line Track 250 A

Isc max. in kA rms		25 kA	36 kA	50 kA	70 kA	100 kA	150 kA
Type of circuit breaker	Compact NSX	NSX160B/F/N/H/S/L	NSX160F/N/H/S/L	NSX160N/H/S/L	NSX160H/S/L	NSX160S/L	NSX160L
		<b>NSX250B/F/N/H/S/L</b>	<b>NSX250F/N/H/S/L</b>	<b>NSX250N/H/S/L</b>	<b>NSX250H/S/L</b>	<b>NSX250S/L</b>	<b>NSX250L</b>
		NSX400F/N/H/S/L	NSX400F/N/H/S/L	NSX400N/H/S/L	-	-	-

#### Type of I-Line Track 400 A

Isc max. in kA rms		25 kA	36 kA	50 kA	70 kA	100 kA	150 kA
Type of circuit breaker	Compact NSX	NSX250B/F/N/H/S/L	NSX250F/N/H/S/L	NSX250N/H/S/L	NSX250H/S/L	NSX250S/L	NSX250L
		<b>NSX400F/N/H/S/L</b>	<b>NSX400F/N/H/S/L</b>	<b>NSX400N/H/S/L</b>	<b>NSX400H/S/L</b>	<b>NSX400S/L</b>	<b>NSX400L</b>
		NSX630F/N/H/S/L	NSX630F/N/H/S/L	NSX630N/H/S/L	NSX630H/S/L	NSX630S/L	NSX630L
	Compact NS	NS630b N/H/L/LB	NS630b L/LB	NS630b L/LB	NS630b LB	-	-

C

#### Type of I-Line Track 630 A

Isc max. in kA rms		≤ 32 kA	36 kA	50 kA	70 kA	100 kA	150 kA
Type of circuit breaker	Compact NSX	NSX400F/N/H/S/L	NSX400F/N/H/S/L	NSX400N/H/S/L	NSX400H/S/L	NSX400S/L	NSX400L
		<b>NSX630F/N/H/S/L</b>	<b>NSX630F/N/H/S/L</b>	<b>NSX630N/H/S/L</b>	<b>NSX630H</b>	<b>NSX630S/L</b>	<b>NSX630L</b>
	Compact NS	NS630b N/H/L/LB	NS630b L/LB	NS630b L/LB	NS630b L/LB	NS630b L/LB	NS630b LB
	Masterpact MTZ1	NS800N/H/L/LB	NS800L/LB	NS800L/LB	NS800L/LB	NS800L/LB	NS800LB
		MTZ1 06 H1/H2/H3/L1	MTZ1 06 L1	MTZ1 06 L1	MTZ1 06 L1	MTZ1 06 L1	-
		MTZ1 08 H1/H2/H3/L1	MTZ1 08 L1	MTZ1 08 L1	MTZ1 08 L1	MTZ1 08 L1	-

D

### Selection guide for Ue: 660-690 V AC

E

#### Type of I-Line Track 250 A

Isc max. in kA rms		10 kA	15 kA	20 kA	25 kA	45 kA	75 kA	100 kA
Type of circuit breaker	Compact NSX	NSX160N/H/S/L	NSX160S/L	NSX160L	-	-	-	-
		<b>NSX250N/H/S/L</b>	<b>NSX250S/L</b>	<b>NSX250L</b>	<b>NSX250R</b>	<b>NSX250R</b>	<b>NSX250HB1</b>	<b>NSX250HB2</b>
		NSX400F/N/H/S/L	NSX400H/S/L	NSX400H/S/L	-	-	-	-

#### Type of I-Line Track 400 A

Isc max. in kA rms		10 kA	15 kA	20 kA	25 kA	45 kA	75 kA	100 kA
Type of circuit breaker	Compact NSX	NSX250N/H/S/L	NSX250S/L	NSX250L	NSX250R	NSX250R	NSX250HB1	NSX250HB2
		<b>NSX400F/N/H/S/L</b>	<b>NSX400F/N/H/S/L</b>	<b>NSX400H/S/L</b>	<b>NSX400S/L</b>	<b>NSX400R</b>	<b>NSX400HB1</b>	<b>NSX400HB2</b>
		NSX630F/N/H/S/L	NSX630F/N/H/S/L	NSX630H/S/L	NSX630S/L	<b>NSX630R</b>	<b>NSX400HB1</b>	<b>NSX400HB2</b>
	Compact NS	NS630b N/H/LB	NS630b N/H/LB	NS630b N/H/LB	NS630b LB	NS630b LB	NS630b LB	-

#### Type of I-Line Track 630 A

Isc max. in kA rms		10 kA	15 kA	20 kA	25 kA	45 kA	75 kA	100 kA
Type of circuit breaker	Compact NSX	NSX400F/N/H/S/L	NSX400H/S/L	NSX400H/S/L	NSX400S/L	NSX400R	NSX400HB1	NSX400HB2
		<b>NSX630F/N/H/S/L</b>	<b>NSX630H/S/L</b>	<b>NSX630H/S/L</b>	<b>NSX630S/L</b>	<b>NSX630R</b>	<b>NSX630HB1</b>	<b>NSX630HB2</b>
	Compact NS	NS630b N/H/LB				NS630b LB		-
		NS800N/H/LB				NS800LB		-

# Index

I-Line Track .....E-2

## I-Line Track

Cat. numbers	Description	Page
<b>A</b>		
ITSC250ES42BI0500E	END FEED BOX 250A CU 3L+N+PE IP42	C-6
ITSC250ES42BINNM1E	END FEED BOX NSXN 250A CU 3L+N+PE IP42	C-6
ITSC250ES42BO0500E	END FEED BOX 250A CU 3L+N+PE IP42	C-6
ITSC250ES42BONNM1E	END FEED BOX NSXN 250A CU 3L+N+PE IP42	C-6
ITSC250ES42EIE	ELBOW 250A CU 3L+N+PE IP42	C-5
ITSC250ES42EOE	ELBOW 250A CU 3L+N+PE IP42	C-5
ITSC250ES42JKE	JOINT PAK 250A CU 3L+N+PE IP42	C-4
ITSC250ES42ST1200E	STRAIGHT 250A CU 3L+N+PE IP42 1.2M	C-4
ITSC250ES42ST3000E	STRAIGHT 250A CU 3L+N+PE IP42 3M	C-4
ITSC250ES42STAE	STRAIGHT 250A CU 3L+N+PE IP42 MADE TO MEASURE	C-4
ITSC250ES42STBE	STRAIGHT 250A CU 3L+N+PE IP42 MADE TO MEASURE	C-4
<b>B</b>		
ITSC250GS42BI0500E	END FEED BOX 250A CU 3L+N+PER IP42	C-6
ITSC250GS42BINNM1E	END FEED BOX NSXN 250A CU 3L+N+PER IP42	C-6
ITSC250GS42BO0500E	END FEED BOX 250A CU 3L+N+PER IP42	C-6
ITSC250GS42BONNM1E	END FEED BOX NSXN 250A CU 3L+N+PER IP42	C-6
ITSC250GS42EIE	ELBOW 250A CU 3L+N+PER IP42	C-5
ITSC250GS42EOE	ELBOW 250A CU 3L+N+PER IP42	C-5
ITSC250GS42JKE	JOINT PAK 250A CU 3L+N+PER IP42	C-4
ITSC250GS42ST1200E	STRAIGHT 250A CU 3L+N+PER IP42 1.2M	C-4
ITSC250GS42ST3000E	STRAIGHT 250A CU 3L+N+PER IP42 3M	C-4
ITSC250GS42STAE	STRAIGHT 250A CU 3L+N+PER IP42 MADE TO MEASURE	C-4
ITSC250GS42STBE	STRAIGHT 250A CU 3L+N+PER IP42 MADE TO MEASURE	C-4
<b>C</b>		
ITSC400ES42BI0500E	END FEED BOX 400A CU 3L+N+PE IP42	C-6
ITSC400ES42BINNM1E	END FEED BOX NSXN 400A CU 3L+N+PE IP42	C-6
ITSC400ES42BO0500E	END FEED BOX 400A CU 3L+N+PE IP42	C-6
ITSC400ES42BONNM1E	END FEED BOX NSXN 400A CU 3L+N+PE IP42	C-6
ITSC400ES42EIE	ELBOW 400A CU 3L+N+PE IP42	C-5
ITSC400ES42EOE	ELBOW 400A CU 3L+N+PE IP42	C-5
ITSC400ES42JKE	JOINT PAK 400A CU 3L+N+PE IP42	C-4
ITSC400ES42ST1200E	STRAIGHT 400A CU 3L+N+PE IP42 1.2M	C-4
ITSC400ES42ST3000E	STRAIGHT 400A CU 3L+N+PE IP42 3M	C-4
ITSC400ES42STAE	STRAIGHT 400A CU 3L+N+PE IP42 MADE TO MEASURE	C-4
ITSC400ES42STBE	STRAIGHT 400A CU 3L+N+PE IP42 MADE TO MEASURE	C-4
<b>D</b>		
ITSC400GS42BI0500E	END FEED BOX 400A CU 3L+N+PER IP42	C-6
ITSC400GS42BINNM1E	END FEED BOX NSXN 400A CU 3L+N+PER IP42	C-6
ITSC400GS42BO0500E	END FEED BOX 400A CU 3L+N+PER IP42	C-6
ITSC400GS42BONNM1E	END FEED BOX NSXN 400A CU 3L+N+PER IP42	C-6
ITSC400GS42CIE	RIGHT END CLOSURE 400A CU IP42	C-7
ITSC400GS42COE	LEFT END CLOSURE 400A CU IP42	C-7
ITSC400GS42EIE	ELBOW 400A CU 3L+N+PER IP42	C-5
ITSC400GS42EOE	ELBOW 400A CU 3L+N+PER IP42	C-5
ITSC400GS42JKE	JOINT PAK 400A CU 3L+N+PER IP42	C-4
ITSC400GS42ST1200E	STRAIGHT 400A CU 3L+N+PER IP42 1.2M	C-4
ITSC400GS42ST3000E	STRAIGHT 400A CU 3L+N+PER IP42 3M	C-4
ITSC400GS42STAE	STRAIGHT 400A CU 3L+N+PER IP42 MADE TO MEASURE	C-4
ITSC400GS42STBE	STRAIGHT 400A CU 3L+N+PER IP42 MADE TO MEASURE	C-4
<b>E</b>		
ITSC630GS42BI0500E	END FEED BOX 630A CU 3L+N+PER IP42	C-6
ITSC630GS42BINNM1E	END FEED BOX - CB 630A CU 3L+N+PER IP42	C-6
ITSC630GS42BO0500E	END FEED BOX 630A CU 3L+N+PER IP42	C-6
ITSC630GS42BONNM1E	END FEED BOX - CB 630A CU 3L+N+PER IP42	C-6
ITSC630GS42CIE	RIGHT END CLOSURE 630A CU IP42	C-7
ITSC630GS42COE	LEFT END CLOSURE 630A CU IP42	C-7
ITSC630GS42EIE	ELBOW 630A CU 3L+N+PER IP42	C-5
ITSC630GS42EOE	ELBOW 630A CU 3L+N+PER IP42	C-5
ITSC630GS42FB01	SINGLE ROD HANGER	C-8
ITSC630GS42FB02	DOUBLE ROD HANGER	C-8
ITSC630GS42JKE	JOINT PAK 630A CU 3L+N+PER IP42	C-4
ITSC630GS42ST1200E	STRAIGHT 630A CU 3L+N+PER IP42 1.2M	C-4
ITSC630GS42ST3000E	STRAIGHT 630A CU 3L+N+PER IP42 3M	C-4
ITSC630GS42STAE	STRAIGHT 630A CU 3L+N+PER IP42 MADE TO MEASURE	C-4
ITSC630GS42STBE	STRAIGHT 630A CU 3L+N+PER IP42 MADE TO MEASURE	C-4
ITSM000E42EB1E	TAP-OFF UNIT T1 FOR 2X16-32A SOCKET IP42	C-2
ITSM000E42EB2E	TAP-OFF UNIT T2 FOR 3X16-32A SOCKET IP42	C-2
ITSM000E42EB3E	TAP-OFF UNIT T3 FOR 2X63A SOCKET IP42	C-2
ITSM000FP421E	FRONT PLATE T1 FOR 1X63A SOCKET IP42	C-3
ITSM000FP422E	FRONT PLATE T2 FOR 2X63A SOCKET IP42	C-3



Life Is On | **Schneider**  
Electric

**Schneider Electric Industries SAS**

35, rue Joseph Monier  
CS 30323  
92506 Rueil Malmaison Cedex  
France

RCS Nanterre 954 503 439  
Capital social 896 313 776 €  
[www.se.com](http://www.se.com)

11-2023  
DEBU038EN

© 2023 - Schneider Electric. All Rights Reserved.  
All trademarks are owned by Schneider Electric Industries SAS or its affiliated companies.