

# xEffect - Industrial Switchgear Range Residual Current Devices FRCmM-125









Catalog



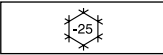

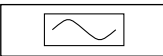

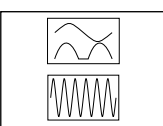

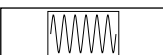
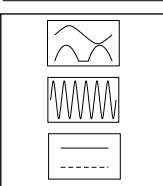
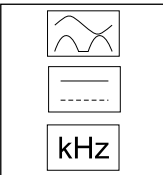
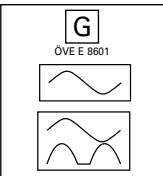
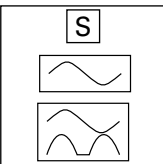















Powering Business Worldwide

**Residual Current Devices - General Data**

**Short description of the most important RCD types**

Symbol	Description
	Eaton standard. Suitable for outdoor installation (distribution boxes for outdoor installation and building sites) up to -25° C.
	Conditionally surge-current proof (>250 A, 8/20 μs) for general application.
	Type AC: AC current sensitive RCCB
	Type A: AC and pulsating DC current sensitive RCCB, not affected by smooth DC fault currents up to 6 mA
	Type F: AC and pulsating DC current sensitive RCCB, trips also at frequency mixtures (10 Hz, 50 Hz, 1000 Hz), min. 10 ms time-delayed, min. 3 kA surge current proof, higher load capacity with smooth DC fault currents up to 10 mA
	Frequency range up to 20 kHz
	Trips also at frequency mixtures (10 Hz, 50 Hz, 1000 Hz)
	Type B: All-current sensitive RCD switchgear for applications where DC fault currents may occur. Non-selective, non-delayed. Protection against all kinds of fault currents.
	Type B+: All-current sensitive RCD switchgear for applications where DC fault currents may occur. Non-selective, non-delayed. Protection against all kinds of fault currents. Provides enhanced fire safety.
	RCD of type G (min 10 ms time delay) surge current-proof up to 3 kA. For system components where protection against unwanted tripping is needed to avoid personal injury and damage to property. Also for systems involving long lines with high capacitive reactance. Some versions are sensitive to pulsating DC. Some versions are available in all-current sensitive design.
	RCD of type S (selective, min 40 ms time delay) surge current-proof up to 5 kA. Mainly used as main switch, as well as in combination with surge arresters. This is the only RCD suitable for series connection with other types if the rated tripping current of the downstream RCD does not exceed one third of the rated tripping current of the device of type S. Some versions are sensitive to pulsating DC. Some versions are available in all-current sensitive design.

### Kind of residual current and correct use of RCD Types

Kind of current	Current profile	Correct use / application field of RCCB types						Tripping current
		AC	A	F	B	/ B+		
Sinusoidal AC residual current							0.5 to 1.0 $I_{\Delta n}$	
Pulsating DC residual current (positive or negative half-wave)		-					0.35 to 1.4 $I_{\Delta n}$	
Cut half-wave current		-					Lead angle 90°: 0.25 to 1.4 $I_{\Delta n}$ Lead angle 135°: 0.11 to 1.4 $I_{\Delta n}$	
Half-wave with smooth DC current of 6 mA		-					max. 1.4 $I_{\Delta n}$ + 6 mA	
Half-wave with smooth DC current of 10 mA		-	-				max. 1.4 $I_{\Delta n}$ + 10 mA	
Smooth DC current		-	-	-			0.5 to 2.0 $I_{\Delta n}$	

### Tripping time

#### Break time and non-actuating time for alternating residual currents (r.m.s. values) for type AC and A RCCB

Classification	$I_{\Delta n}$ mA		$I_{\Delta n}$	$2xI_{\Delta n}$	$5xI_{\Delta n}$	$5 x I_{\Delta n}$ or 0.25A	500A
Standard RCD Conditionally surge current-proof 250 A	≤30	Max. tripping time (s)	0.3	0.15		0.04	0.04
Standard RCD Conditionally surge current-proof 250 A	>30	Max. tripping time (s)	0.3	0.15	0.04		0.04
RCCB Type G (Short-time-delay) Surge current-proof 3 kA	30	Min. non actuating time(s) Max. tripping time (s)	0.01 0.3	0.01 0.15		0.01 0.04	0.01 0.04
RCCB Type G (Short-time-delay) Surge current-proof 3 kA	>30	Min. non actuating time(s) Max. tripping time (s)	0.01 0.3	0.01 0.15	0.01 0.04		0.01 0.04
RCCB Type S (Selective) Surge current-proof 5 kA	>30	Min. non actuating time(s) Max. tripping time (s)	0.13 0.5	0.06 0.2	0.05 0.15		0.04 0.15

#### Break time for half-wave pulsating residual currents (r.m.s. values) for type A RCCB

Classification	$I_{\Delta n}$ mA		$1.4xI_{\Delta n}$	$2xI_{\Delta n}$	$2.8xI_{\Delta n}$	$4xI_{\Delta n}$	$7 x I_{\Delta n}$ 0.35 A	0.5 A	350A
Standard RCD Conditionally surge current-proof 250 A	<30	Max. tripping time (s)		0.3		0.15			0.04
Standard RCD Conditionally surge current-proof 250 A	30	Max. tripping time (s)	0.3		0.15		0.04		0.04
Standard RCD Conditionally surge current-proof 250 A	>30	Max. tripping time (s)	0.3		0.15		0.04		0.04
RCCB Type G (Short-time-delay) Surge current-proof 3 kA	30	Max. tripping time (s)	0.3		0.15		0.04		0.04
RCCB Type G (Short-time-delay) Surge current-proof 3 kA	>30	Max. tripping time (s)	0.3		0.15		0.04		0.04
RCCB Type S (Selective) Surge current-proof 5 kA	>30	Max. tripping time (s)	0.5		0.2		0.15		0.15

**Tripping Characteristics (IEC/EN 61008)**

**Tripping characteristics, tripping time range and selectivity of instantaneous, surge current-proof „G“ and surge current-proof - selective „S“ residual current devices.**

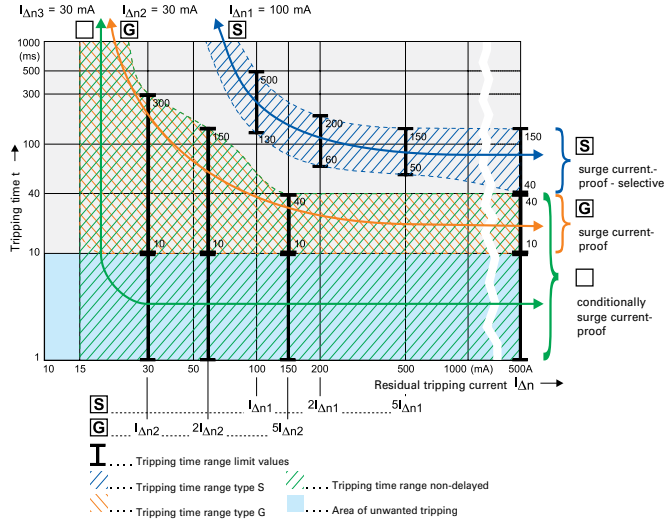

**IEC 60364-4-41** deals with additional protection: The use of RCDs with a rated residual operating current not exceeding 30 mA, is recognized in a.c. systems as additional protection in the event of failure of the provision for basic protection and/or the provision for fault protection or carelessness by users.

**This means when using RCDs for fault current/residual current protection two RCDs must be connected in series.**

**Testing:**

RCDs with tripping time delay (Types -G and -S) may be function tested with conventional testing equipment which must be set according to the instructions for operation of the testing device. Due to reasons inherent in the measuring process, the tripping time determined in this way may be longer than expected in accordance with the specifications of the manufacturer of the measuring instrument.

However, the device is ok if the result of measurement is within the time range specified by the manufacturer of the measuring instrument.

### Applications with frequency converters:

Due to the currents flowing off through the filters (designated IF), the sum of currents through the RCD is not exactly zero, which causes unwanted tripping.

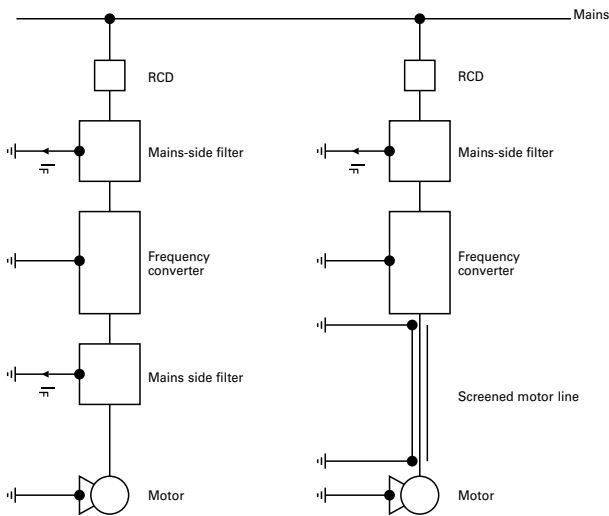

Frequency converters are used in a wide variety of systems and equipment requiring variable speed, such as lifts, escalators, conveyor belts, and large washing machines. Using them for such purposes in circuits with conventional residual current devices causes frequent problems with unwanted tripping.

The technical root cause of this phenomenon is the following: Fast switching operations involving high voltages cause high interference levels which propagate through the lines on the one hand, and in the form of interfering radiation on the other. In order to eliminate this problem, a mains-side filter (also referred to as input filter or EMC-filter) is connected between the RCD and frequency converter. The anti-interference capacitors in the filters produce discharge currents against earth which may cause unwanted tripping of the RCD due to the apparent residual currents. Connecting a filter on the output side between frequency converter and 3-phase AC motor results in the same behaviour.

### Tripping characteristic

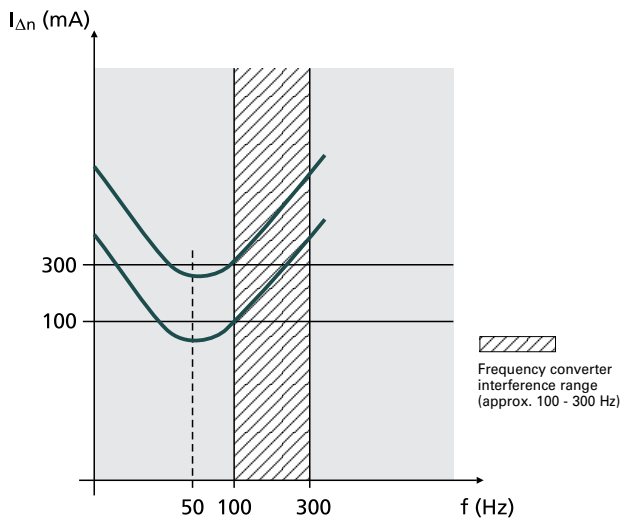

This sample tripping characteristic of a 100 mA RCD and a 300 mA RCD shows the following: In the frequency range around 50 Hz, the RCDs trip as required (50 - 100 % of the indicated  $I_{\Delta n}$ ). In the range shown hatched in the diagram, i. e. from approx. 100 to 300 Hz, unwanted tripping occurs frequently due to the use of frequency converters. Type F RCCBs are designed to reliably sense higher frequency residual currents, which leads to an enormous increase in the reliability and availability of electrical systems.

### Therefore, we recommend to use RCDs designed for applications with frequency converter!

These special residual current devices can be recognised by an extension of the type designation („-F“). They meet the requirements of compatibility between RCDs and frequency converters with respect to unwanted tripping.

Eaton stands for highest availability of your system also in applications where frequency drives are used. Therefore a full suite of Type F RCCBs (mechanical and digital assisted) are available in all feasible ratings to assist you in your application needs.

Our RCDs of type „-F“ are characterized by:

- Improved capabilities of reliably sensing residual currents up to 1 kHz
- Improved capabilities of withstanding 10 mA DC offset
- 10 ms short time delay minimum (G/F)
- Surge current proofness of 3 kA (G/F) and 5 kA (S/F)

SG08013



## Description

- Comprehensive range of RCCBs with a rating of 125A
- All current sensitive Type B RCCBs to fulfil highest safety standards
- Line voltage independent 2 and 4 pole RCCB for fault protection, additional protection as well as fire protection
- As also stated in IEC/EN 62423, the B sensitivity relies on line voltage



# 1.6

## Residual Current Devices

xEffect

Residual Current Devices FRCmM-125 Type AC, A, B, Bfg and B+

$I_n/I_{\Delta n}$ (A)	Type Designation	Article No.	Units per package
---------------------------	---------------------	-------------	----------------------

### Type AC

Conditionally surge current-proof 250 A, Type AC 

SG07913



#### 2-poles

125/0,03	FRCMM-125/2/003	187810	1/60
125/0,1	FRCMM-125/2/01	187811	1/60
125/0,3	FRCMM-125/2/03	187812	1/60
125/0,5	FRCMM-125/2/05	187813	1/60

SG08013



#### 4-poles

125/0,03	FRCMM-125/4/003	187814	1/30
125/0,1	FRCMM-125/4/01	187815	1/30
125/0,3	FRCMM-125/4/03	187816	1/30
125/0,5	FRCMM-125/4/05	187817	1/30

### Type A

Conditionally surge current-proof 250 A, sensitive to residual pulsating DC, Type A 

SG07913



#### 2-poles

125/0.03	FRCMM-125/2/003-A	171164	1/60
125/0.1	FRCMM-125/2/01-A	171165	1/60
125/0.3	FRCMM-125/2/03-A	171166	1/60
125/0.5	FRCMM-125/2/05-A	171167	1/60

SG08013



#### 4-poles

125/0.03	FRCMM-125/4/003-A	171174	1/30
125/0.1	FRCMM-125/4/01-A	171175	1/30
125/0.3	FRCMM-125/4/03-A	171176	1/30
125/0.5	FRCMM-125/4/05-A	171177	1/30

$I_n/I_{\Delta n}$   
(A)

Type  
Designation

Article No. Units per  
package

**Type G/A**

**Short-time delayed, surge current-proof 3 kA, sensitive to residual pulsating DC, Type G/A** 

SG07913



**2-poles**

125/0.03	FRCMM-125/2/003-G/A	171168	1/60
125/0.1	FRCMM-125/2/01-G/A	171169	1/60
125/0.3	FRCMM-125/2/03-G/A	171170	1/60

SG08013



**4-poles**

125/0.03	FRCMM-125/4/003-G/A	171178	1/30
125/0.1	FRCMM-125/4/01-G/A	171179	1/30
125/0.3	FRCMM-125/4/03-G/A	171180	1/30

**Type S/A**

**Selective + surge current-proof 5 kA, sensitive to residual pulsating DC, Type S/A** 

SG07913



**2-poles**

125/0.1	FRCMM-125/2/01-S/A	171171	1/60
125/0.3	FRCMM-125/2/03-S/A	171172	1/60
125/0.5	FRCMM-125/2/05-S/A	171173	1/60

SG08013



**4-poles**

125/0.1	FRCMM-125/4/01-S/A	171181	1/30
125/0.3	FRCMM-125/4/03-S/A	171182	1/30
125/0.5	FRCMM-125/4/05-S/A	171183	1/30



$I_n/I_{\Delta n}$ (A)	Type Designation	Article No.	Units per package
---------------------------	---------------------	-------------	----------------------

#### Type B

**Surge current-proof 3 kA, all-current sensitive, Type B** 

##### 4-poles

125/0.03	FRCMM-125/4/003-B	171184	1/30
125/0.1	FRCMM-125/4/01-B	171185	1/30
125/0.3	FRCMM-125/4/03-B	171186	1/30
125/0.5	FRCMM-125/4/05-B	171187	1/30

SG08013



#### Type G/B

**Short-time delayed, surge current-proof 3 kA, all-current sensitive, Type G/B** 

##### 4-poles

125/0.03	FRCMM-125/4/003-G/B	171188	1/30
----------	---------------------	--------	------

SG08013



#### Type S/Bfq

**Selective + surge current-proof 5 kA, all-current sensitive, Type S/Bfq** 

##### 4-poles

125/0.3	FRCMM-125/4/03-S/BFQ	171190	1/30
125/0.5	FRCMM-125/4/05-S/BFQ	171191	1/30

SG08013

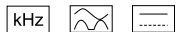

#### Type G/B+

**Short-time delayed, surge current-proof 3 kA, all-current sensitive, Type G/B+** 

##### 4-poles

125/0.03	FRCMM-125/4/003-G/B+	171189	1/30
----------	----------------------	--------	------

SG08013



**Specifications | Residual Current Devices FRCmM-125, Type A**

**Description**

**Design**

- Residual Current Circuit Breakers (RCCBs) for application with higher rated nominal current
- Twin-purpose terminal (lift/open-mouthed) above and below
- Contact position indicator red - green
- The device functions irrespective of the position of installation

**Accessories**

- Auxiliary contact Z-HD to be mounted onto the device

**Additional information for the application**

- Tripping is line voltage independent (VI) and therefore suitable for all BA-classes.

The RCD is suitable for fault protection, additional protection, fire protection within the regulations of the applicable wiring regulations (e.g.: IEC/EN 60364)

**Test Button**

- The test button "T" must be pressed once every 6 months. The system operator must be informed of this obligation and his responsibility in a way that can be proven.  
Under special conditions (e.g.: damply and/or dusty environments, environments with polluting and/or corroding conditions, environments with large temperature fluctuations, installations with a risk of overvoltage due to switching of equipment and/or atmospheric discharges, portable equipment, ...), it's recommended to test in monthly intervals. Regulations according IEC/EN 60364 or wiring regulations still apply.
- The test button "T" tests the function of the RCCB itself. This test does not measure a "suitable" fault loop or if requirements of such are kept. Testing your fault loop (earth rod resistance, continuity of fault loop,...) requires special tests performed separately.

- **Type A:** These types are capable of sensing pulsating residual currents and are not negatively affected by a DC overlay of up to 6mA. These devices (dependent on the range) are also available as:
  - G/A short time delayed devices which are surge current proof up to 3 kA. These devices enable a reliable and safe installation with increased system availability
  - S/A selective RCCBs with improved surge current capabilities up to 5 kA. These devices are selective (conditions apply) to other RCDs and enable special applications and root installations.
- **Type G:** G Types offer a 10ms time delayed tripping curve and surge current proof capabilities up to 3kA and are highly recommended to be used for applications and installations where system availability is an important factor. Since "G" states a tripping curve and not a sensitivity, these devices (dependent on the range) will be found as:
  - A Type RCCBs (-G/A)
- **Type S:** S Types offer a 40ms time delayed tripping curve and surge current proof capabilities up to 5kA and are known as "selective" types. These devices are mainly used in root applications with additional RCDs deployed in series in the system. Since "S" states a tripping curve and not a sensitivity, these devices (dependent on the range) will be found as:
  - S/A Type RCCBs

**Accessories:**

Auxiliary switch for subsequent installation to the left

Z-HD

265620

### Technical Data

		FRCmM-125A, Type AC, A, G/A and S/A
<b>Electrical</b>		
Design according to		IEC/EN 61008
Current test marks as printed onto the device		
Tripping		instantaneous
Type G/A		10 ms delay
Type S/A		50 ms delay - with selective disconnecting function
Rated voltage	$U_n$	240/415 V; 50 Hz
Limits operation voltage test circuit		
30 mA		150 - 250 V~
100, 300, 500 mA		185 - 440 V~
Rated tripping current	$I_{\Delta n}$	30, 100, 300, 500 mA
Sensitivity		AC and pulsating DC
Rated insulation voltage	$U_i$	400 V
Rated impulse withstand voltage	$U_{imp}$	2,5 kV
Rated short circuit capacity	$I_{cn}$	10 kA with back-up fuse
Peak withstand current		
Type A		250 A (8/20 $\mu$ s), surge current-proof
Type G/A		3 kA (8/20 $\mu$ s), surge current-proof, 10 ms delay
Type S/A		5 kA (8/20 $\mu$ s), surge current-proof, 40 ms delay
Maximum back-up fuse		Short circuit protection    Overload protection
		125 A gG/gL                      80 A gG/gL
Rated breaking capacity	$I_m$	1250 A
or rated fault breaking capacity	$I_{\Delta m}$	
Endurance		
electrical components		$\geq 4,000$ operating cycles
mechanical components		$\geq 10,000$ operating cycles
<b>Mechanical</b>		
Frame size		45 mm
Device height		80 mm
Device width		35 mm (2MU), 70 mm (4MU)
Mounting		quick fastening with DIN rail EN50022
Degree of protection, built-in		IP40
Upper and lower terminals		open mouthed/lift terminals
Terminal protection		finger and hand touch safe, DGUV VS3, EN 50274
Terminal capacity		1,5 - 50 mm <sup>2</sup>
Busbar thickness		0.8 - 2 mm
Operation temperature		-25°C to +40°C
Storage- and transport temperature		-25°C to +60°C
Resistance to climatic conditions		25-55°C/90-95% relative humidity acc. to IEC 60068-2
Mounting position		any

### Connection diagram

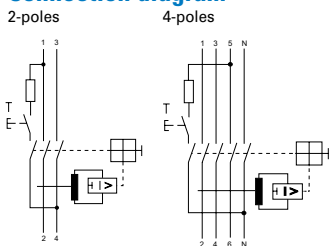

### Dimensions (mm)

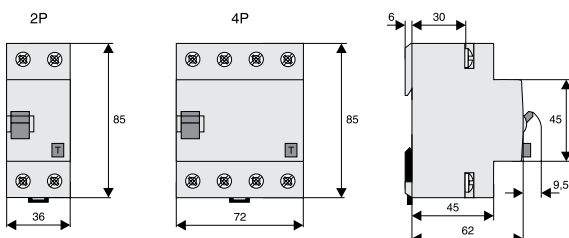

**Power Loss at  $I_n$  FRCmM-125 - Type AC, A, G/A and S/A**

(entire unit)

$I_n$ [A]	P [W]
<b>2-poles</b>	
125	18
<b>4-poles</b>	
125	22.5

---

**Specifications | Residual Current Devices FRcmM-125, Type B, Bfg and B+**

---

**Description****Design**

- All current sensitive Residual Current Circuit Breakers (RCCBs) for application with higher rated nominal current
- Twin-purpose terminal (lift/open-mouthed) above and below
- Contact position indicator red - green
- The device functions irrespective of the position of installation

**Accessories**

- Auxiliary contact Z-HD to be mounted onto the device

**Additional information for the application**

- Tripping is line voltage independent (VI) and therefore suitable for all BA-classes.

The RCD is suitable for fault protection, additional protection, fire protection within the regulations of the applicable wiring regulations (e.g.: IEC/EN 60364)

- As also stated in IEC/EN 62423, the B sensitivity relies on line voltage

**Test Button**

- The test button "T" must be pressed once every 6 months. The system operator must be informed of this obligation and his responsibility in a way that can be proven.

Under special conditions (e.g.: damply and/or dusty environments, environments with polluting and/or corroding conditions, environments with large temperature fluctuations, installations with a risk of overvoltage due to switching of equipment and/or atmospheric discharges, portable equipment, ...), it's recommended to test in monthly intervals. Regulations according IEC/EN 60364 or wiring regulations still apply.

- The test button "T" tests the function of the RCCB itself. This test does not measure a "suitable" fault loop or if requirements of such are kept. Testing your fault loop (earth rod resistance, continuity of fault loop,...) requires special tests performed separately

- **Type B (fq, +):** These types offer the highest safety levels in electrical systems due to their all-current sensitivity and best in class reliability and system availability. Special type B from Eaton are available:

- B+ limit the possibility of electrical ignited fires and should be considered for fire hazard applications as also mentioned in VDE-0664-400

- Bfq are capable of reliably sensing residual currents up to 100 kHz

- **Type G:** G Types offer a 10ms time delayed tripping curve and surge current proof capabilities up to 3kA and are highly recommended to be used for applications and installations where system availability is an important factor.

Since "G" states a tripping curve and not a sensitivity, these devices (dependent on the range) will be found as:

- B/B+ Type RCCBs (-G/B(+))

- **Type S:** S Types offer a 40 ms time delayed tripping curve and surge current proof capabilities up to 5 kA and are known as "selective" types. These devices are mainly used in root applications with additional RCDs deployed in series in the system.

Since "S" states a tripping curve and not a sensitivity, these devices (dependent on the range) will be found as:

- S/Bfq Type RCCBs

**Accessories:**

---

Auxiliary switch for subsequent installation to the left

Z-HD

265620

---

**Technical Data**

		FRCmM-125A, Type B, Bfg and B+
<b>Electrical</b>		
Design according to		IEC/EN 61008
Current test marks as printed onto the device		
Tripping		
Type B, G/B, G/B+		short-time delayed
Type S/Bfq		50 ms delay - with selective disconnecting function
Rated voltage	$U_n$	240/415 V; 50 Hz
Limits operation voltage test circuit		
30 mA		250 - 440 V~
100, 300, 500 mA		185 - 440 V~
Rated tripping current	$I_{\Delta n}$	30, 100, 300, 500 mA
Sensitivity		All types of current
Rated insulation voltage	$U_i$	400 V
Rated impulse withstand voltage	$U_{imp}$	2,5 kV
Rated short circuit capacity	$I_{cn}$	10 kA with back-up fuse
Peak withstand current		
Type B		3 kA (8/20 $\mu$ s), surge current-proof
Type G/B, G/Bfg, G/B+		3 kA (8/20 $\mu$ s), surge current-proof, 10 ms delay
Type S/Bfg		5 kA (8/20 $\mu$ s), surge current-proof, 40 ms delay
Maximum back-up fuse		
		Short circuit protection      Overload protection
		125 A gG/gL                      80 A gG/gL
Rated breaking capacity	$I_m$	1250 A
or rated fault breaking capacity	$I_{\Delta m}$	
Endurance		
electrical components		$\geq 4,000$ operating cycles
mechanical components		$\geq 10,000$ operating cycles
<b>Mechanical</b>		
Frame size		45 mm
Device height		80 mm
Device width		70 mm (4MU) für 2-poles and 4-poles
Mounting		quick fastening with DIN rail EN50022
Degree of protection, built-in		IP40
Upper and lower terminals		open mouthed/lift terminals
Terminal protection		finger and hand touch safe, DGUV VS3, EN 50274
Terminal capacity		1,5 - 50 mm <sup>2</sup>
Busbar thickness		0.8 - 2 mm
Operation temperature		-25°C to +40°C
Storage- and transport temperature		-25°C to +60°C
Resistance to climatic conditions		25-55°C/90-95% relative humidity acc. to IEC 60068-2
Mounting position		any

**Connection diagram**

4-poles

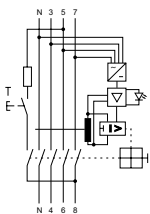

**Dimensions (mm)**

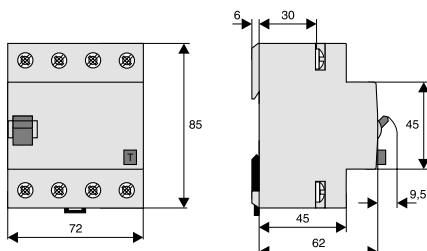



### Power Loss at $I_n$ FRCmM-125 - Type B, Bfg and B+

(entire unit)

$I_n$ [A]	P [W]
<b>4-poles</b>	
125	22.5

### Tripping current frequency response FRCmM-125 - Type B, Bfg and B+

Tripping current frequency response 30 mA Type B

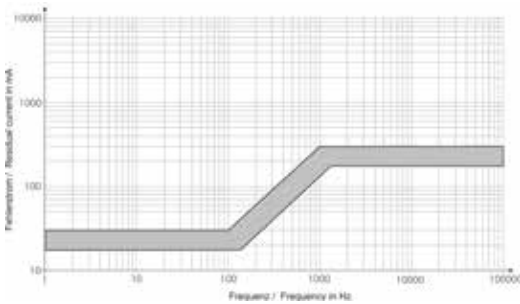

Tripping current frequency response 30 mA Type G/B+

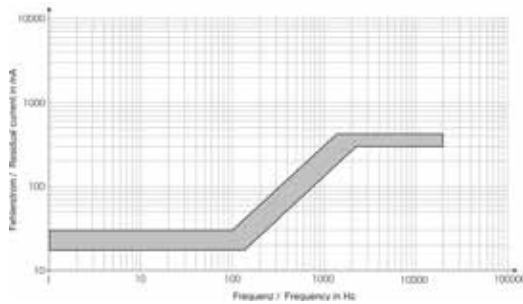

Tripping current frequency response 30 mA Type G/B

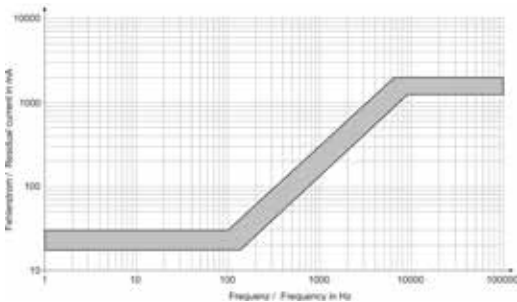

Tripping current frequency response 100 mA Type B

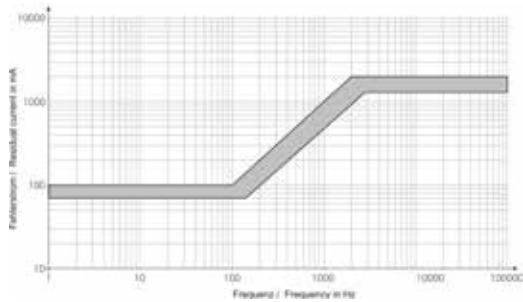

Tripping current frequency response 300 mA Type S/Bfg

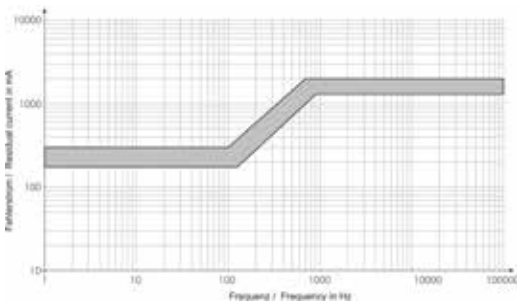

Tripping current frequency response 500 mA Type S/Bfg

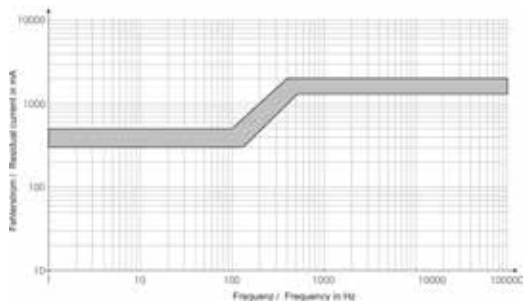

Eaton's electrical business is a global leader with deep regional application expertise in power distribution and circuit protection; power quality, backup power and energy storage; control and automation; life safety and security; structural solutions; and harsh and hazardous environment solutions. Through end-to-end services, channel and an integrated digital platform & insights Eaton is powering what matters across industries and around the world, helping customers solve their most critical electrical power management challenges.

For more information, visit [Eaton.com](https://www.eaton.com).



**Eaton Industries (Austria) GmbH**  
Scheydgasse 42  
1210 Vienna  
Austria

**Eaton**  
EMEA Headquarters  
Route de la Longeraie 7  
1110 Morges, Switzerland

© 2022 Eaton  
All Rights Reserved  
Publication No. CA003020EN  
Article number 302007-MK  
June 2022

Changes to the products, to the information contained in this document, and to prices are reserved; as are errors and omissions. Only order confirmations and technical documentation by Eaton is binding. Photos and pictures also do not warrant a specific layout or functionality. Their use in whatever form is subject to prior approval by Eaton. The same applies to trademarks (especially Eaton, Moeller, and Cutler-Hammer). The Terms and Conditions of Eaton apply, as referenced on Eaton Internet pages and Eaton order confirmations.

Eaton is a registered trademark.

All other trademarks are property of their respective owners.

Follow us on social media to get the latest product and support information.

