

Walraven RapidStrut® channel DS 5 (BUP1000)

(H0405)

for medium weight fixing applications

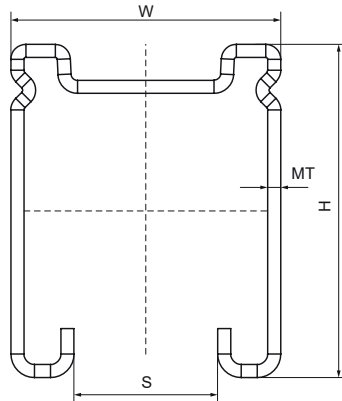

Features & benefits

- for a quick and easy fixing
- unique hole pattern, allowing Walraven RapidStrut® Accessories to be mounted on both sides of the channel
- very high corrosion resistance (Walraven UltraProtect® 1000)
- corrosion protection remains intact after cutting
- strength minimal equal to Walraven RapidStrut® 41x41x2.5 mm
- with continuous perforation
- distance between channel end and first hole is always equal
- a continuous graduated centimetre scale on one side
- inward formed flanges with serrated profile for extra grip
- material: steel 1.0242
- product is part of the Walraven UltraProtect® 1000 system
- suitable for in- and outdoor applications
- stands min. 1,000 hours salt spray test (max. 5% red rust) according to ISO 9227
- for more information about the max. allowed load (Faz) please refer to the loading tables or our online datasheet 'Walraven RapidStrut® Data Sheet'



Product Number	VVS Number	Type	Total Height	Total Width	Total Length	Material Thickness	Profile Opening
Reference Letter			H	W	L	MT	S
Unit description			mm	mm	mm	mm	mm
65058252	18040392	51 M	51	41	2,000	2.00	22
65058352	18040393	51 M	51	41	3,000	2.00	22
65058652	18040396	51 M	51	41	6,000	2.00	22