

PowerXL™

DC1...E1 Variable Frequency Drives Fire Mode



Level 2	<p>1 – Fundamental – No previous experience necessary</p> <p>2 – Basic – Basic knowledge recommended</p> <p>3 – Advanced – Reasonable knowledge required</p> <p>4 – Expert – Good experience recommended</p>
---------	--

Contents

- 1 General 5
- 2 Configuration of DC1...E1 for Fire Mode 6
 - 2.1 Activation of the Fire Mode 6
 - 2.2 Start Mode (P-30) and Spin Start Enable (P-33) 7
 - 2.3 Display values 8
- 3 How does the device DC1...E1 behave in Fire Mode? 9
 - 3.1 Which protective functions are deactivated? 9
 - 3.2 Behavior of the device 9
 - 3.2.1 1 Sense of Rotation, 1 Analog Reference, 1 Fixed Frequency (P-15 = 15) 10
 - 3.2.2 2 Senses of Rotation, 2 Fixed Frequencies (P-15 = 16) 10
 - 3.2.3 1 Sense of Rotation, 4 Fixed Frequencies (P-15 = 17) 10

Danger! - Dangerous electrical voltage!

- Disconnect the power supply of the device.
- Ensure that devices cannot be accidentally restarted.
- Verify isolation from the supply.
- Cover or enclose any adjacent live components.
- Follow the engineering instructions (AWA/IL) for the device concerned.
- Only suitably qualified personnel in accordance with EN 50110-1/-2 (VDE 0105 Part 100) may work on this device/system.
- Before installation and before touching the device ensure that you are free of electrostatic charge.
- The functional earth (FE, PES) must be connected to the protective earth (PE) or the potential equalization. The system installer is responsible for implementing this connection.
- Connecting cables and signal lines should be installed so that inductive or capacitive interference does not impair the automatic control functions.
- Suitable safety hardware and software measures should be implemented for the I/O interface so that an open circuit on the signal side does not result in undefined states.
- Deviations of the mains voltage from the rated value must not exceed the tolerance limits given in the specification, otherwise this may cause malfunction and/or dangerous operation.
- Emergency stop devices complying with IEC/EN 60204-1 must be effective in all operating modes. Unlatching of the emergency-stop devices must not cause a restart.
- Devices that are designed for mounting in housings or control cabinets must only be operated and controlled after they have been properly installed and with the housing closed.
- Wherever faults may cause injury or material damage, external measures must be implemented to ensure a safe operating state in the event of a fault or malfunction (e.g. by means of separate limit switches, mechanical interlocks etc.).
- Frequency inverters may have hot surfaces during and immediately after operation.
- Removal of the required covers, improper installation or incorrect operation of motor or frequency inverter may destroy the device and may lead to serious injury or damage.
- The applicable national safety regulations and accident prevention recommendations must be applied to all work carried on live frequency inverters.
- The electrical installation must be carried out in accordance with the relevant electrical regulations (e. g. with regard to cable cross sections, fuses, PE).
- Transport, installation, commissioning and maintenance work must be carried out only by qualified personnel (IEC 60364, HD 384 and national occupational safety regulations).
- Installations containing frequency inverters must be provided with additional monitoring and protective devices in accordance with the applicable safety regulations. Modifications to the frequency inverters using the operating software are permitted.
- All covers and doors must be kept closed during operation.
- To reduce the hazards for people or equipment, the user must include in the machine design measures that restrict the consequences of a malfunction or failure of the frequency inverter (increased motor speed or sudden standstill of motor). These measures include: – Other independent devices for monitoring safety related variables (speed, travel, end positions etc.).
 - Electrical or non-electrical system-wide measures (electrical or mechanical interlocks).
 - Never touch live parts or cable connections of the frequency inverter after it has been disconnected from the power supply. Due to the charge in the capacitors, these parts may still be alive after disconnection. Consider appropriate warning signs.

Disclaimer

The information, recommendations, descriptions, and safety notations in this document are based on Eaton's experience and judgment and may not cover all contingencies. If further information is required, an Eaton sales office should be consulted. Sale of the product shown in this literature is subject to the terms and conditions outlined in the applicable Terms and Conditions for Sale of Eaton or other contractual agreement between Eaton and the purchaser. THERE ARE NO UNDERSTANDINGS, AGREEMENTS, WARRANTIES, EXPRESSED OR IMPLIED, INCLUDING WARRANTIES OF FITNESS FOR A PARTICULAR PURPOSE OR MERCHANTABILITY, OTHER THAN THOSE SPECIFICALLY SET OUT IN ANY EXISTING CONTRACT BETWEEN THE PARTIES. ANY SUCH CONTRACT STATES THE ENTIRE OBLIGATION OF EATON. THE CONTENTS OF THIS DOCUMENT SHALL NOT BECOME PART OF OR MODIFY ANY CONTRACT BETWEEN THE PARTIES. As far as applicable mandatory law allows so, in no event will Eaton be responsible to the purchaser or user in contract, in tort (including negligence), strict liability, or otherwise for any special, indirect, incidental, or consequential damage or loss whatsoever, including but not limited to damage or loss of use of equipment, plant or power system, cost of capital, loss of power, additional expenses in the use of existing power facilities, or claims against the purchaser or user by its customers resulting from the use of the information, recommendations, and descriptions contained herein. The information contained in this manual is subject to change without notice.

1 General

Devices of the series **PowerXL™ DC1...E1** have internal protective functions, to prevent them from being destroyed. When a protective function is activated, either the device is switched off or a message is displayed.

In case of a fire, the lives of human beings and animals must be protected. For that reason it is important, that smoke extractors and sprinklers still work, even in case of a fault, which normally leads to a shutdown.

Depending on the application different requirements exist, how a device has to behave in case of fire. It starts with bypassing of electronic devices and a direct connection of the motor to the supplying mains to the point of a special behavior of the variable frequency drive. The operating mode of the variable frequency drive in case of fire is called Fire Mode.

The Variable Speed Drives Group of the British Manufacturers Organization GAMBICA defines the Fire Mode as follows:

Fire Mode is a special operating mode of the VSD that is activated by a dedicated signal that specifically indicates a fire condition. Once operating in Fire Mode the VSD will ignore or reset faults in order to maintain availability.

Fire Mode cannot be triggered by any other signal or manual option. Once the VSD enters Fire Mode, it cannot exit this mode until the fire condition signal is reset.

2 Configuration of DC1...E1 for Fire Mode

2.1 Activation of the Fire Mode

The function "Fire Mode" is activated by selecting a specific terminal configuration, which enables the connection of a signal dedicated to Fire Mode. Independently from the setting of P-12 "Local ProcessData Source" this is the case, when P-15 "DI Config Select" is either set to 15, 16 or 17.

The table below shows a configuration example for terminal mode (P-12 = 0)

P-12 = 0: Terminal mode				
P-15	DI1 (Terminal 2)	DI2 (Terminal 3)	DI3/AI2 (Terminal 4)	DI4/AI1 (Terminal 6)
0	START	DIR	Select AI1 REF / f-Fix1	AI1 REF
1	FWD	Select AI1 REF / f-Fix	Select f-Fix Bit0	AI1 REF
2	FWD	Select f-Fix Bit0	Select f-Fix Bit1	Select f-Fix / f-max
3	FWD	Select AI1 REF / f-Fix1	EXTFLT	AI1 REF
4	FWD	Select AI1 REF / AI2 REF	AI2 REF	AI1 REF
5	FWD	REV	Select AI1 REF / f-Fix1	AI1 REF
6	START	DIR	EXTFLT	AI1 REF
7	FWD	REV	EXTFLT	AI1 REF
8	START	DIR	Select f-Fix Bit0	Select f-Fix Bit1
9	FWD	REV	Select f-Fix Bit0	Select f-Fix Bit1
10	Pulse FWD (NO)	Pulse STOP (NC)	Select AI1 REF / f-Fix1	AI1 REF
11	Pulse FWD (NO)	Pulse STOP (NC)	Pulse REV (NO)	AI1 REF
12	FWD	Select t-dec / t-QuickDec	Select AI1 REF / f-Fix1	AI1 REF
13	FWD	Select f-Fix Bit0	EXTFLT	Select f-Fix Bit1
14	Pulse FWD (NO)	Pulse STOP (NC)	Pulse REV (NO)	Select DIG REF / f-Fix1
15	FWD	Select f-Fix4 / AI1 REF	Select Fire Mode / Normal OP	AI1 REF
16	START	Select f-Fix4 / f-Fix2	Select Fire Mode / Normal OP	DIR
17	FWD	Select f-Fix Bit0	Select Fire Mode / Normal OP	Select f-Fix Bit1

For the terminal functions, the following abbreviations are used:

Abbreviation	Function															
AI1 REF	Analog input AI1 (terminal 6) is used as speed reference input. P-16: Format (voltage input / current input ...) P-35: Scaling P-39: Offset															
DIR	Used for the selection of the sense of rotation in connection with the START command. Low = cw (FWD) High = ccw (REV)															
FWD	START with a clockwise rotating field (FWD = Forward). When applying a High signal to the respective terminal, the drive accelerates with the predefined ramp. Removing the signal leads to a stop. The stop behavior depends on the setting of P-05 "Stop Mode". At standstill the variable frequency drive is disabled.															
Select f-Fix Bit 0 Select f-Fix Bit 1	Selection of the fixed frequency with digital commands. The fixed frequencies f-Fix1 ... f-Fix4 are defined with P-20 ... P-23. <table border="1" data-bbox="544 1839 1177 2020"> <thead> <tr> <th></th> <th>Bit 1</th> <th>Bit 0</th> </tr> </thead> <tbody> <tr> <td>f-Fix 1 (P-20)</td> <td>Low</td> <td>Low</td> </tr> <tr> <td>f-Fix 2 (P-21)</td> <td>Low</td> <td>High</td> </tr> <tr> <td>f-Fix 3 (P-22)</td> <td>High</td> <td>Low</td> </tr> <tr> <td>f-Fix 4 (P-23)</td> <td>High</td> <td>High</td> </tr> </tbody> </table>		Bit 1	Bit 0	f-Fix 1 (P-20)	Low	Low	f-Fix 2 (P-21)	Low	High	f-Fix 3 (P-22)	High	Low	f-Fix 4 (P-23)	High	High
	Bit 1	Bit 0														
f-Fix 1 (P-20)	Low	Low														
f-Fix 2 (P-21)	Low	High														
f-Fix 3 (P-22)	High	Low														
f-Fix 4 (P-23)	High	High														

Abbreviation	Function
Select f-fix4 / AI1REF	Selection between f-Fix4 and the analog reference at terminal 6 Low = f-Fix4, High = analog reference
Select f-fix4 / f-Fix2	Selection between f-Fix4 and f-Fix2 Low = f-Fix4, High = f-Fix2
Select Fire Mode / Normal OP	The Fire Mode function enables the operation of the variable frequency drive in emergency situations until it cannot work anymore. Potential fault messages are ignored. Low = Fire Mode, High = normal operation
START	Starts the drive. When applying a High signal to the respective terminal, the drive accelerates with the predefined ramp. Removing the signal leads to a stop. The stop behavior depends on the setting of P-05 "Stop Mode". At standstill the variable frequency drive is disabled. In applications with two directions the command DIR is used.

2.2 Start Mode (P-30) and Spin Start Enable (P-33)

During Fire Mode fault messages are ignored. In case of fault conditions, in which the device is physically not able to operate, e.g. with a short circuit at the output, the device trips and performs an automatic restart afterwards. By default the variable frequency drives of the series DC1...E1 need a rising edge of the START signal to start (P-30 = *Ed9P-r*). An automatic restart is impossible with this setting.

In case the Fire Mode function is used, P-30 has to be set to *Auto-0 ... Auto-5*!

In addition it is recommended to enable the spin start function (P-33 = 1) to prevent trips because of overcurrent, when starting a spinning motor. This is quite often the case with fans having a big inertia.

See also: Application Note AP040054EN „Start, Stop and Operation“.

2.3 Display values

Information about Fire Mode can be displayed on the keypad.

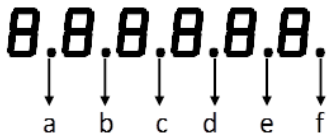

A blinking dot “a” shows, that the variable frequency drive is running in Fire Mode.

PNU	Parameter	Name
821.11	P00-47	t-FireMode Aktive
841.58370		FaultCounter Fire detected

Parameter P00-47 gives historical information about Fire Mode. It is inside level 3 of the parameters. This level has to be activated by prompting the password into P-14 (Password). The password is “201” by default.

See also: AP040052EN “Access to Parameter Level 2 + 3 – Parameter lock – Load Default”.

Access to parameter P00-47:

- Activate parameter level 3
- Select **P-00** with keys ▲ and ▼ on the keypad
- Press **OK**
- Select **P00-47** with keys ▲ and ▼ on the keypad
- Press **OK**
- The number of hours is displayed, in which the device has operated in Fire Mode (e.g. **h 1**)
- Press ▲
- Minutes and seconds are displayed, e.g. **06:50**
- Press ▲
- It is displayed, how many times the device was in Fire Mode, e.g. **2**.
- Press **OK** for approximately 2 s to quit.

The device of the example above was 2 times in Fire Mode for a total of 1 hour, 6 minutes and 50 seconds.

3 How does the device DC1...E1 behave in Fire Mode?

3.1 Which protective functions are deactivated?

In Fire Mode the following protective functions are deactivated:

Message	Possible cause
<i>I-E-ErrP</i>	Motor is overloaded. The thermal protection has tripped after delivering > 100 % of the current set in P-08 for a certain time.
<i>O-t</i>	Heatsink overtemperature. The drive is too hot.
<i>U-t</i>	Undertemperature. This message is displayed, when the ambient temperature is below – 10 °C.
<i>th-FLt</i>	Thermistor on the heatsink is faulty.
<i>E-Err iP</i>	External fault (at Digital Input 3, Terminal 4).
<i>SC-ErrP</i>	Loss of the serial communication
<i>Ph-1 b</i>	Phase imbalance of the input voltage
<i>P-LOSS</i>	Loss of an input phase (only at devices with a 3 phase supply)
<i>4-20 F</i>	Analog input current out of range

In case one of the faults listed below occurs, the variable frequency drive trips and restarts automatically. The number of the attempts for a restart depends on the setting of P-30: 1 attempt with P-30 = *Auto-1* ... 5 attempts with *Auto-5*. After the maximum number of attempts the variable frequency drive trips with a fault message. With P-30 = *Auto-0* the number of attempts is not limited.

Message	Possible cause
<i>O-I</i>	Instantaneous overcurrent on the drive output
<i>h-OI</i>	Fast overcurrent trip
<i>OUE-F</i>	Drive output fault, output stage trip
<i>OUal t</i>	Overvoltage in the d.c. link
<i>UUal t</i>	Undervoltage in the d.c. link

3.2 Behavior of the device

During normal operation the „Fire Mode“ contact in the examples below is closed and 24 V are present at terminal 4 (DI3). In case of a fire alarm the contact opens and the variable frequency drive acts as described in chapter 3.1. In addition it has to be noted, that the motor has to have a defined sense of rotation and speed. The different possibilities depend on the terminal configuration, set with P-15. Examples see below.

NOTE: The variable frequency drive returns to normal operation as soon as the voltage at terminal 4 recovers. When the Fire Mode signal needs to be latched, because an intentional reset needs to be done manually, the latching has to be foreseen external from the variable frequency drive. In many cases this function is part of the fire alarm system.

3.2.1 1 Sense of Rotation, 1 Analog Reference, 1 Fixed Frequency (P-15 = 15)

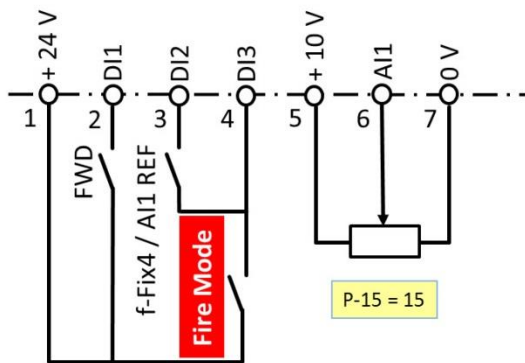

- Normal operation:
 - „Fire Mode“ closed
 - Start with FWD
 - Speed according signal at DI2:
 - Low: f-Fix4
 - High: reference at AI1
- In case of fire:
 - „Fire Mode“ open
 - speed = f-Fix4, set with P-23

NOTE: the contact FWD needs always to be closed.

3.2.2 2 Senses of Rotation, 2 Fixed Frequencies (P-15 = 16)

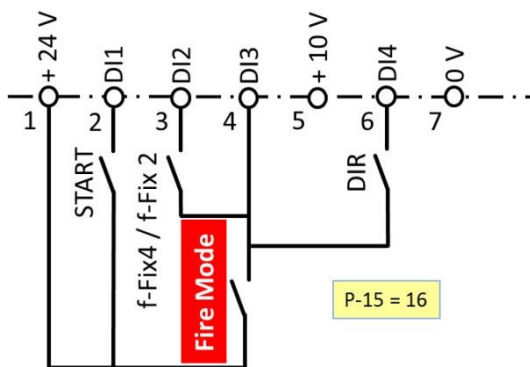

- Normal operation:
 - „Fire Mode“ closed
 - Start with START
 - Sense according signal at DI4:
 - Low: clockwise
 - High: counter clockwise
 - Speed according signal at DI2:
 - Low: f-Fix4
 - High: f-Fix2

- In case of fire:
 - „Fire Mode“ open
 - sense of rotation: clockwise
 - speed: f-Fix4, set with P-23

NOTE: the contact START needs always to be closed. It MUST be ensured, that the motor turns into the direction it has to turn in case of fire, when the DC1...E1 has a right rotating field at its output terminals.

3.2.3 1 Sense of Rotation, 4 Fixed Frequencies (P-15 = 17)

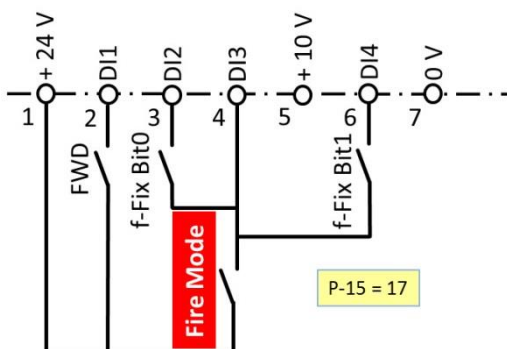

- Normal operation:
 - „Fire Mode“ closed
 - Start with FWD
 - Speed (signals at DI2 and DI4)
 - 4 Fixed Frequencies f-fix1...4
 - See table in chapter 2.1
- In case of fire:
 - „Fire Mode“ open
 - speed = f-Fix1, set with P-20

NOTE: the contact FWD needs always to be closed.