

an ideal tomorrow

ait
HEAT PUMPS



Operating Manual

Wall-mounted controller WR 21

Accessory for heat pumps

UK

www.aitgroup.com

83071900cUK



Table of contents

1	About this operating manual	3	Technical data / Scope of supply	12
1.1	Validity.....	3	Residual head	13
1.2	Reference documents	3	Dimensioned drawings	14
1.3	Symbols and markings.....	3	Drill pattern	14
1.4	Contact	4	Installation plan.....	15
2	Safety	4	Terminal diagrams.....	16
2.1	Intended use	4	Circuit diagram.....	19
2.2	Personnel qualifications.....	4		
2.3	Personal protective equipment	4		
2.4	Residual risks	5		
3	Operation and maintenance	5		
3.1	Energy and environmentally-conscious operation.....	5		
3.2	Maintenance	5		
4	Compatible products	5		
5	Scope of supply.....	5		
5.1	Accessories.....	5		
5.2	Components of the unit.....	6		
6	Storage, transport, installation	6		
6.1	Storage	6		
6.2	Transport and unpacking	6		
6.3	Installation	6		
7	Install the hydraulic connections	7		
7.1	Circulation pump	7		
7.2	Volumetric flow meter / heat meter.....	8		
7.3	Supply and return sensor.....	9		
7.4	Outdoor sensor.....	9		
8	Electrical installation	9		
8.1	Establish electrical connections	9		
8.2	Electrical connection	10		
9	Control panel	11		
10	Commissioning	11		
11	Faults.....	11		
12	Dismantling and disposal.....	11		
12.1	Dismantling	11		
12.2	Disposal and recycling	11		



1 About this operating manual

This operating manual is part of the unit.

- ▶ Before working on or with the unit, read the operating manual carefully and follow it for all activities at all times, especially the warnings and safety instructions.
- ▶ Keep the operating manual to hand at the unit and pass on to the new owner if the unit changes hands.
- ▶ If you have any questions or anything is unclear, ask the manufacturer's local partner or the factory's customer service.
- ▶ Note and follow all other reference documents.

1.1 Validity

This operating manual refers solely to the unit identified by the nameplate.

1.2 Reference documents

The following documents contain additional information to this operating manual:

- Planning & design manual, hydraulic integration
- Operating manual of the heat pump
- Operating manual of the heating and heat pump controller
- Brief description of the heat pump controller
- Operating manual of the expansion board (accessory)
- Installation manual of the circulation pump
- Installation manual of the volumetric flow meter

1.3 Symbols and markings

Identification of warnings

Symbol	Meaning
	Safety-relevant information. Warning of physical injuries.
	Safety-relevant information. Warning of physical injuries. Flammable materials / flammable (primary) refrigerant
	Safety-relevant information. Warning of physical injuries. Flammable materials / flammable (primary) refrigerant

Symbol	Meaning
	Safety-relevant information. Warning of physical injuries. Danger of fatal injury due to electric current.
DANGER	Indicates imminent danger resulting in severe injuries or death.
WARNING	Indicates a potentially dangerous situation, which can result in severe injuries or death.
CAUTION	Indicates a potentially dangerous situation, which can result in moderate or minor injuries.
IMPORTANT	Indicates a potentially dangerous situation, which can result in property damage.

Symbols in the document

Symbol	Meaning
	Information for qualified personnel
	Information for the owner/operator
✓	Requirement for action
▶	Procedural instructions: Single step action prompt
1., 2., 3., ...	Procedural instructions: Numbered step within a multi-step action prompt. Keep to the given order.
	Additional information, e.g. a tip on making work easier, information on standards
→	Reference to further information elsewhere in the operating manual or in another document
•	Listing
	Secure connections against twisting



1.4 Contact

Addresses for purchasing accessories, for service cases or for answers to questions about the unit and this operating manual can be found on the internet and are kept up-to-date:

- www.aitgroup.com

2 Safety

Only use the unit when it is in flawless technical condition and only use it as intended, safely and aware of the hazards, and follow this operating manual.

2.1 Intended use

The unit is designed for household use and, combined with a compatible air/water heat pump, is solely intended for the following purposes

- Heating
 - Domestic hot water preparation
 - Cooling
- ▶ Intended use includes complying with the operating conditions (→ “Technical data / Scope of supply”, page 12) and the operating manual and observing and following the reference documents.
- ▶ When using the local regulations note: laws, standards, guidelines, directives.

All other uses of the unit are not as intended.

2.2 Personnel qualifications

The operating manuals supplied with the product are intended for all users of the product.

The operation of the product via the heating and heat pump control and work on the product which is intended for end customers / operators is suitable for all age groups of persons who are able to understand the activities and the resulting consequences and can carry out the necessary activities.

Children and adults who are not experienced in handling the product and do not understand the necessary activities and the resulting consequences must be instructed and, if necessary, supervised by persons experienced in handling the product and who are responsible for safety.

Children must not play with the product.

The product may only be opened by qualified personnel.

All procedural instructions in this operating manual is solely directed at qualified, skilled personnel.

Only qualified, skilled personnel are able to carry out the work on the unit safely and correctly. Interference by unqualified personnel can cause life-threatening injuries and damage to property.

- ▶ Ensure that the personnel is familiar with the local regulations, especially those on safe and hazard-aware working.
- ▶ Ensure that the personnel are qualified to handle flammable (primary) refrigerant.
- Work on the refrigerating circuit may only be carried out by qualified personnel with appropriate qualifications for refrigeration system installation.
- Work on the electrics and electronics may only be carried out by electrical technicians.
- Any other work on the system may only be carried out by qualified personnel (heating installer, plumbing installer).

During the warranty and guarantee period, service work and repairs may only be carried out by personnel authorised by the manufacturer.

2.3 Personal protective equipment

During transport and work on the unit, there is a risk of cuts due to the sharp edges of the unit.

- ▶ Wear cut-resistant protective gloves.

During transport and work on the unit, there is a risk of foot injuries.

- ▶ Wear safety shoes.

When working on liquid-conveying lines, there is a risk of injury to the eyes due to leakage of liquids.

- ▶ Wear safety goggles.



2.4 Residual risks

Injuries caused by electric shock

Components in the unit are energised with life-threatening voltage. Before working on the unit:

- ▶ Disconnect unit from power supply.
- ▶ Secure unit against being switched back on again.

Existing earthing connections within housings or on mounting plates must not be altered. If this should nevertheless be necessary in the course of repair or assembly work:

- ▶ Restore earthing connections to their original condition after completion of the work.

Safety instructions and warning symbols

- ▶ Observe the safety instructions and warning symbols on the packaging and on and in the unit.

3 Operation and maintenance



NOTE

The unit is operated via the control panel of the heating and heat pump controller (→ operating manual of the heating and heat pump controller).

3.1 Energy and environmentally-conscious operation

The generally accepted requirements for an energy-conscious and environmentally-conscious operation of a heating system also apply to use of a heat pump. The most important measures include:

- No unnecessarily high flow temperature
- No unnecessarily high domestic hot water temperature (note and follow local regulations)
- Do not open windows with just a gap or tilt open (continuous ventilation); instead, open wide for a short time (shock ventilation).
- Always ensure that the controller settings are correct

3.2 Maintenance

Wipe down the outside of the unit only using a damp cloth or cloth with mild cleaning agent (washing-up liquid, neutral cleaning agent). Do not use any harsh, abrasive, acid or chlorine-based cleaning products

4 Compatible products

- Hybrox 21
- Helox 21

5 Scope of supply

- Wall-mounted controller with control panel
- Energy-efficient circulation pump with seals as well as power and signal cables with connection cable
- Volumetric flow meter and seals with connection cable
- Supply sensor with connection cable
- Return sensor with connection cable
- Thermal compound
- Fasteners for sensors
- Outdoor sensor
- Operating manual, drill pattern, installation materials

1. Check the delivery for outwardly visible signs of damage.
2. Check the scope of supply for completeness. Any defects or incorrect deliveries must be reported immediately.

5.1 Accessories

The following accessories are available for the unit through the manufacturer's local partner:

- Expansion board with various additional functions
- Room control unit for controlling the main functions from the living room
- Electrical connection kit EVSK
- Domestic hot water tank
- Buffer tank
- Immersion heaters

IMPORTANT

An immersion heater is essential for proper functioning and must be installed and configured. (→“10 Commissioning“, page 11)



5.2 Components of the unit

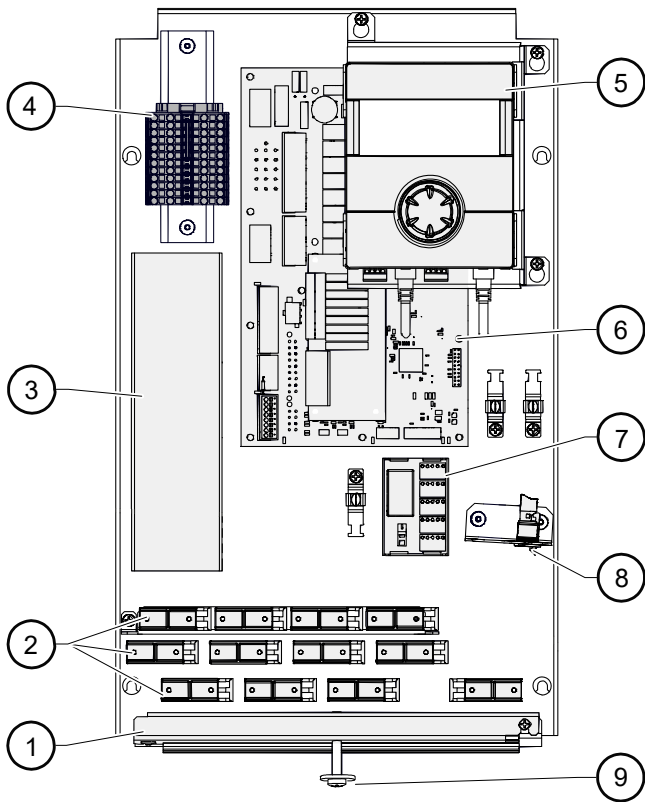

- 1 Cable entry with clamp
- 2 Strain reliefs
- 3 Cable duct
- 4 Connection terminals load cable / control voltage
- 5 Control panel
- 6 Circuit board of heating and heat pump control
- 7 Modbus distributor
- 8 Bus cable connection socket *)
- 9 Closure of the unit front hood

*) for accessories
electrical connection kit EVSK

Nameplate

A nameplate is attached to the outside of the unit at the factory.

The nameplate contains the following information at the very top:

- Model, item number
- Serial number

The nameplate also contains an overview of the most important technical data.

6 Storage, transport, installation

6.1 Storage

- ▶ Store unit protected against:
 - Moisture/damp
 - Frost
 - Dust and dirt

6.2 Transport and unpacking

Notes on safe transport

There is a risk of injuries or damage to property if the unit falls or overturns.



NOTE

To prevent damage during transport, always transport the unit to final installation location in its original packaging.

Carrying the unit

- ▶ Transport the wall-mounted controller to the installation location.

Unpacking

1. Remove plastic films and cardboard. Ensure that you do not damage the unit.
2. Dispose of the transport and packaging material in an environmentally friendly way and in accordance with local regulations.

6.3 Installation

Installation location

IMPORTANT

Install the unit inside buildings only.

The installation area must be frost-free and dry. It must fulfil the relevant local regulations.

Observe safety and service clearances.

→ "Installation plan", page 15, and "Drill pattern", page 14

Assembly

IMPORTANT

The load-bearing capacity of the wall must be guaranteed.



1. Align drill pattern, mark drill holes and drill.
→ “Drill pattern”, page 14
2. Take off the front hood.

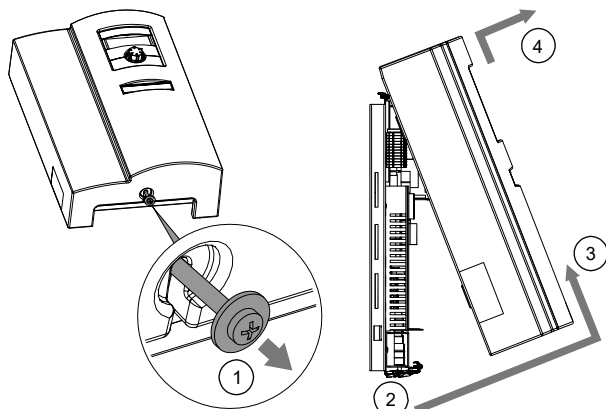

3. Set aside the front hood so that it is protected from damage.
4. Use the plugs and screws supplied to fix the wall-mounted controller onto the wall:

The plugs supplied are only suitable for use with the following types of walls:

- Concrete
- Solid lightweight concrete blocks
- Cavity block made of lightweight concrete
- Cellular concrete
- Prestressed concrete - hollow ceiling/floor slabs
- Natural stone with dense, close-grained micro-structure
- Solid calcium silicate blocks
- Perforated calcium silicate blocks
- Solid bricks
- Vertically perforated (honeycomb) bricks
- Hollow floors/ceilings made of clay bricks, concrete or similar
- Solid gypsum boards
- Gypsum boards and gypsum fibre boards
- Particle boards

The board material must be dimensioned with sufficient thickness to ensure secure fixing. Appropriate fixing material must be provided on site for other types of wall constructions.

IMPORTANT

The gap between the unit and the wall helps back ventilation. It may not be sealed or closed off.

5. Lay cable glands at a distance of at least 2 cm from the wall-mounted controller.

7 Install the hydraulic connections

IMPORTANT

Avoid open heating systems and / or heating systems that are not oxygen diffusion-tight. If this is not possible, a system separation must be installed.

Depending on the dimensioning of the heat exchanger and the additionally required circulation pump, the system separation worsens the energy efficiency of the system.

IMPORTANT

Dirt and deposits in the (existing) hydraulic system can cause damage to the heat pump.

- ▶ Ensure that a air / magnetic sludge separator is installed in the heating circuit.
- ▶ Rinse the hydraulic system thoroughly prior to establishing the hydraulic connection of the heat pump.
- ✓ Cross-sections and lengths of the pipes for the heating circuit are adequately dimensioned.

7.1 Circulation pump



NOTE

Install shut-off devices in front of and behind the circulation pump to facilitate pump replacement when required.

IMPORTANT

Maintain a settling section (straight piping) of at least 5 x DN of the pump flange in front of and behind the circulation pump.



1. Install the circulation pump inside the building according to the approved hydraulic scheme of the heat pump.

Permitted installation positions:

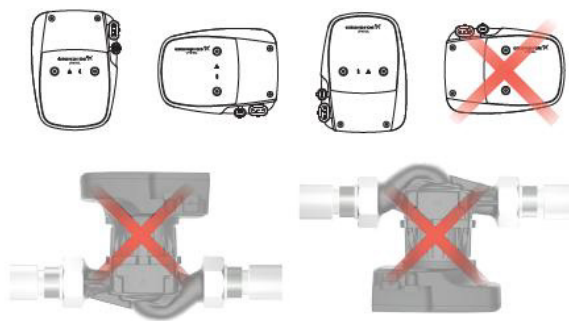
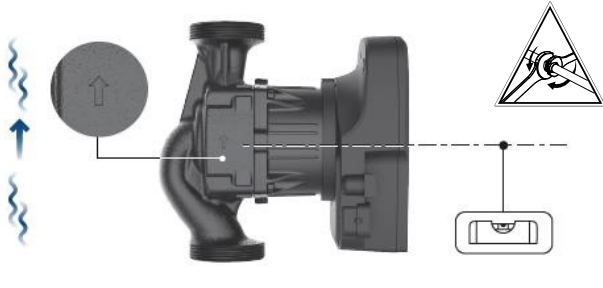

2. Carry out electrical connection work on the circulation pump.
→ Installation manual of the circulation pump
3. Lay the power and signal cables to the wall-mounted controller.

IMPORTANT

Do not shorten the power and signal cables.



NOTE

To ensure effective control of the circulating pump, the minimum pressure loss (Δp_{min}) of the system must not fall below a minimum value.

- for Hybrox 21 / Helox 21 heat pumps:
 Δp_{min} 0,003 bar bei 0,6 m³/h

7.2 Volumetric flow meter / heat meter

IMPORTANT

Maintain a settling section (straight piping) of at least 5 x DN of the connection flange in front of and behind the volumetric flow meter.

1. Install the volumetric flow meter in the heating circuit ahead of the circulation pump inside the building.

Permitted installation positions:

Symbol	Meaning
	<ul style="list-style-type: none"> • any air bubbles can escape upwards • low risk of dirt deposits
	<ul style="list-style-type: none"> • any air bubbles can accumulate (as the highest point of the system) • danger of idling (measuring tube only partially filled)
	<ul style="list-style-type: none"> • possible rise of air bubbles from below • risk of idling

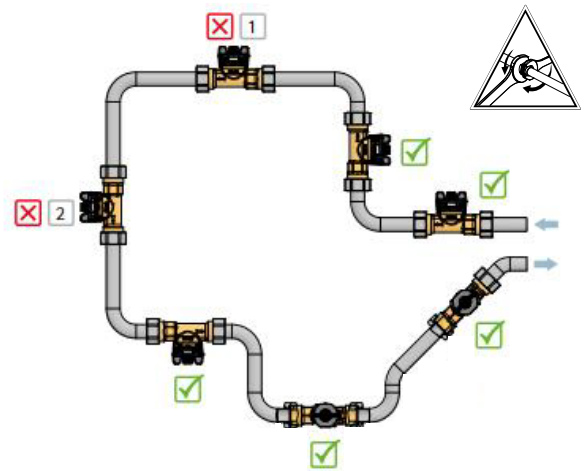

IMPORTANT

Note the flow direction.



NOTE

Fix the piping to the wall in front of and behind the volumetric flow meter if possible.

Example:

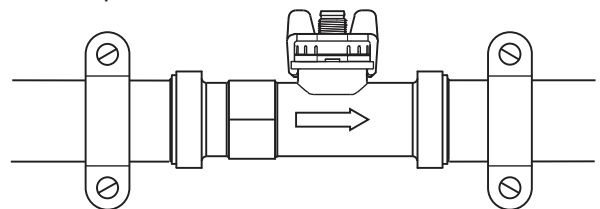

- Installation manual of the volumetric flow meter
2. Lay the connection cable to the wall-mounted controller.

IMPORTANT

Do not shorten the connection cable.



7.3 Supply and return sensor

1. Fasten the supply volumetric flow meter (②) to the heat-conducting pipe of the supply line coming from the heat pump (①) using cable ties and thermal compound.
2. Fasten the return sensor (④) to the heat-conducting pipe of the return line leading to the heat pump (③) using cable ties and thermal compound.

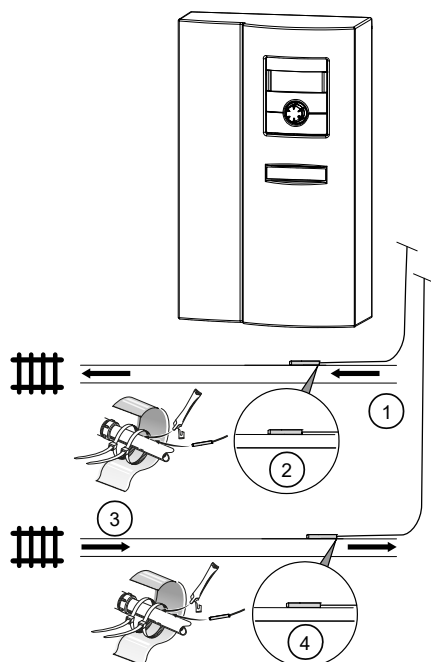

→ Hydraulic integration documents

3. Lay both sensor cables to the wall-mounted controller.

7.4 Outdoor sensor

→ Operating manual of the heating and heat pump controller, part 2

8 Electrical installation

8.1 Establish electrical connections

IMPORTANT

Irreparable damage to the compressor due to wrong rotating field (only applies to units with 400V connection).

- ▶ Ensure that there is a clockwise rotating field for the compressor load infeed.

Basic information on the electrical connection

- The specifications of the local energy supply company may apply to electrical connections
 - Fit the power supply for the heat pump with an all-pole circuit breaker with at least 3 mm contact spacing (per IEC 60947-2)
 - Note the level of the tripping current (→ “Technical data / Scope of supply”, page 12)
 - Comply with the electromagnetic compatibility regulations (EMC regulations)
 - Lay unshielded power supply cables and shielded cables (bus cable) sufficiently far apart (> 100 mm)
 - Maximum line length: 30m
- Cable extension details see operating manual of the heat pump



8.2 Electrical connection

The wall-mounted controller is connected electrically on site according to the following scheme:

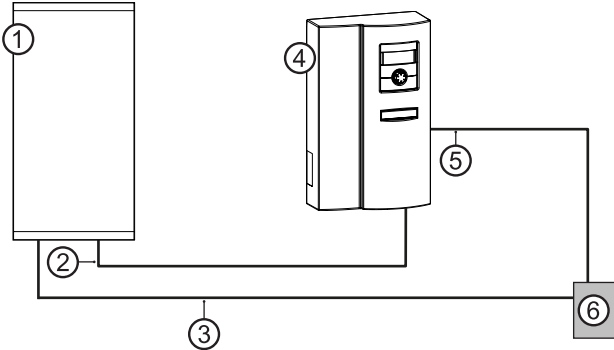

- 1 Heat pump
- 2 Bus cable (shielded)
(on site)
- 3 Load cable compressor
(on site)
- 4 Wall-mounted controller
- 5 Control voltage
- 6 Sub-distribution

1. Fit the connectors to the bus cable of the heat pump.

→ Operating manual of the heat pump

2. Open the clamp (①) of the cable entry.

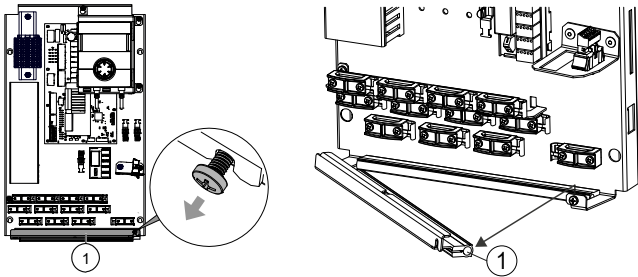

3. Route the wired plug of the heat pump bus cable (②) between the rubber seals (③) and plug it into the socket in the wall-mounted controller.

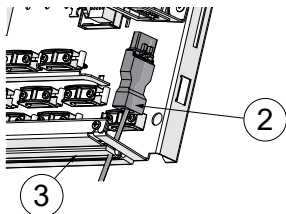

4. Strip the control and sensor cable, of the cable for the EVU blocking time as well as the cables of external loads before feeding them into the wall-mounted controller (stripping length of each of the individual wires: 6 mm).

5. Route cables and wires between the two rubber seals (③), route them through the cable duct in the wall-mounted controller and make the electrical connections in accordance with the terminal diagram.

→ „Terminal diagrams“, from page 16



NOTE

The control panel of the heating and heat pump controller can be connected to a computer or network using a suitable network cable, enabling the heating and heat pump controller to be controlled remotely from there.

If such a connection is desired, route a shielded network cable (category 6, with RJ45 connector) into the wall-mounted controller and plug it to the corresponding socket (②) of the control panel.

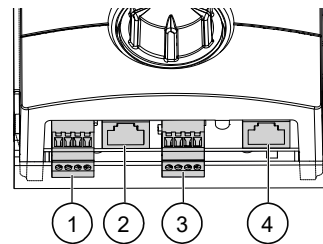

- 1 RS485 for connecting the room control unit RBE (accessory)
- 2 RJ45 for network cable connection
- 3 LIN bus cable connection
- 4 RJ45 connection Modbus cable to Modbus distributor.

6. Route all cables inserted into the switch box through the strain reliefs in the wall-mounted controller and screw the strain reliefs tightly in place.

7. Close the clamp and screw it tightly in place.

8. Put on the front hood of the unit and screw it tightly in place.



9 Control panel

The control panel is pre-assembled at the factory. If the control panel needs to be removed for any reason:

1. Disconnect or unplug all connections at the bottom.
2. Lift off the control panel.

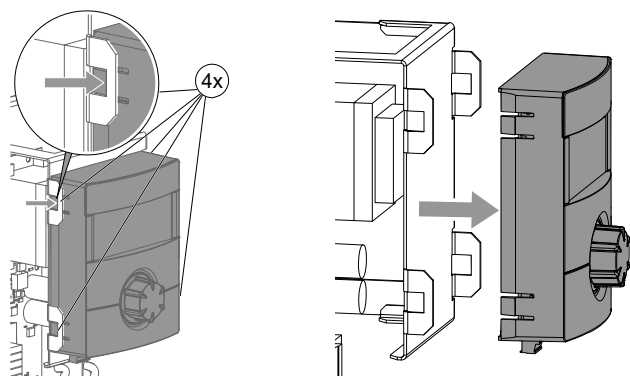

- ▶ To reattach the control panel, proceed in reverse order.

10 Commissioning

IMPORTANT

An immersion heater (→ “5.1 Accessories“, page 5) must be installed for commissioning. For electrical connection, see “Terminal diagrams“, page 16

Check on the control panel of the heating and heat pump controller whether the immersion heater is configured and set as ZWE1.

- Operating manual of the heating and heat pump controller
- Operating manual of the heat pump

11 Faults

- ▶ Read out the cause of the fault via the diagnostics program of the heating and heat pump controller.
- ▶ Contact the local partner of the manufacturer or the factory's customer service. Have the fault message and unit number (→ “Nameplate“, page 6) to hand.

12 Dismantling and disposal

12.1 Dismantling

- ▶ Separate components by their materials.

12.2 Disposal and recycling

- ▶ Recycle or ensure proper disposal of unit components and packaging materials in accordance with local regulations.

Removal of the buffer battery

1. Use a screwdriver to push out the buffer battery on the processor board of the control panel.
2. Dispose of the buffer battery (type: CR2032, lithium) in accordance with local regulations.



WR 21

Technical data / Scope of supply

Accessories for heat pump type			WR 21
Air/water Hybrox / Helox output-controlled	21 kW	• yes – no	•
Installation location			
Room temperature	min. max.	°C	5 35
Relative humidity maximum (non-condensing)		%	60
Sound			
Sound pressure level at 1 m distance	inside	dB(A)	–
Sound power level	inside	dB(A)	–
Heating circuit			
Flow rate: minimum maximum (see heat pump for pipe dimensioning)		l/h l/h	600 3300
Residual head Pressure loss Flow rate		bar bar l/h	0,75 - 3300
Volume flow: minimum nominal analogous to A7W35 (partial load operation) maximum		l/h	600 1150 3300
Max. allowable operating pressure		bar	3
Circulation pump control range	min. max.	l/h	600 3300
General unit data			
Total weight		kg	5,3
Weight of individual components		kg kg kg	- - -
Electrics			
Voltage code all-pole fuse protection for heat pump *)**) 1 phase		... A	- -
Voltage code all-pole fuse protection for heat pump *)**) 3 phases		... A	3~N/PE/400V/50Hz B20
Voltage code Control voltage fuse protection **)		... A	1~N/PE/230V/50Hz B10
Voltage code Electric heating element fuse protection ** 1 phase		... A	- -
Voltage code Electric heating element fuse protection ** 3 phases		... A	- -
Degree of protection		IP	10B
Zmax		Ω	–
Residual current circuit breaker if required		type	B
Electric heating element output 3 2 1 phase		kW kW kW	- - -
Circulation pump power consumption, heating circuit	min. max.	W	3 140
Other unit information			
Safety valve Heating circuit Response pressure		included in scope of supply: • yes – no bar	- -
Buffer tank Volume		included in scope of supply: • yes – no l	- -
Diaphragm expansion vessel Heating circuit Volume Prepressure		incl. in scope of supply: • yes – no l bar	- - -
Overflow valve Changeover valve, heating - domestic hot water		integrated: • yes – no	- -
Vibration decoupling, Heating circuit Heat source		included in scope of supply or integrated: • yes – no	-
Controller Heat quantity recording Extension board		included in scope of supply or integrated: • yes – no	• • -
*) compressor only, **) note local regulations Index: r			813670

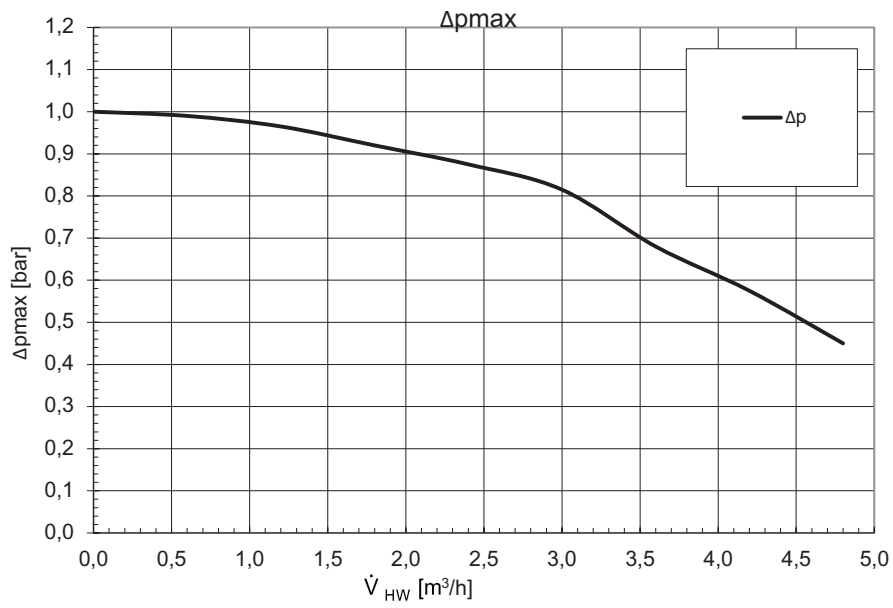

Key: UK823349

\dot{V}_{HW} | Hot water flow rate

Δp_{max} | Maximum residual head



WR 21

Dimensioned drawings

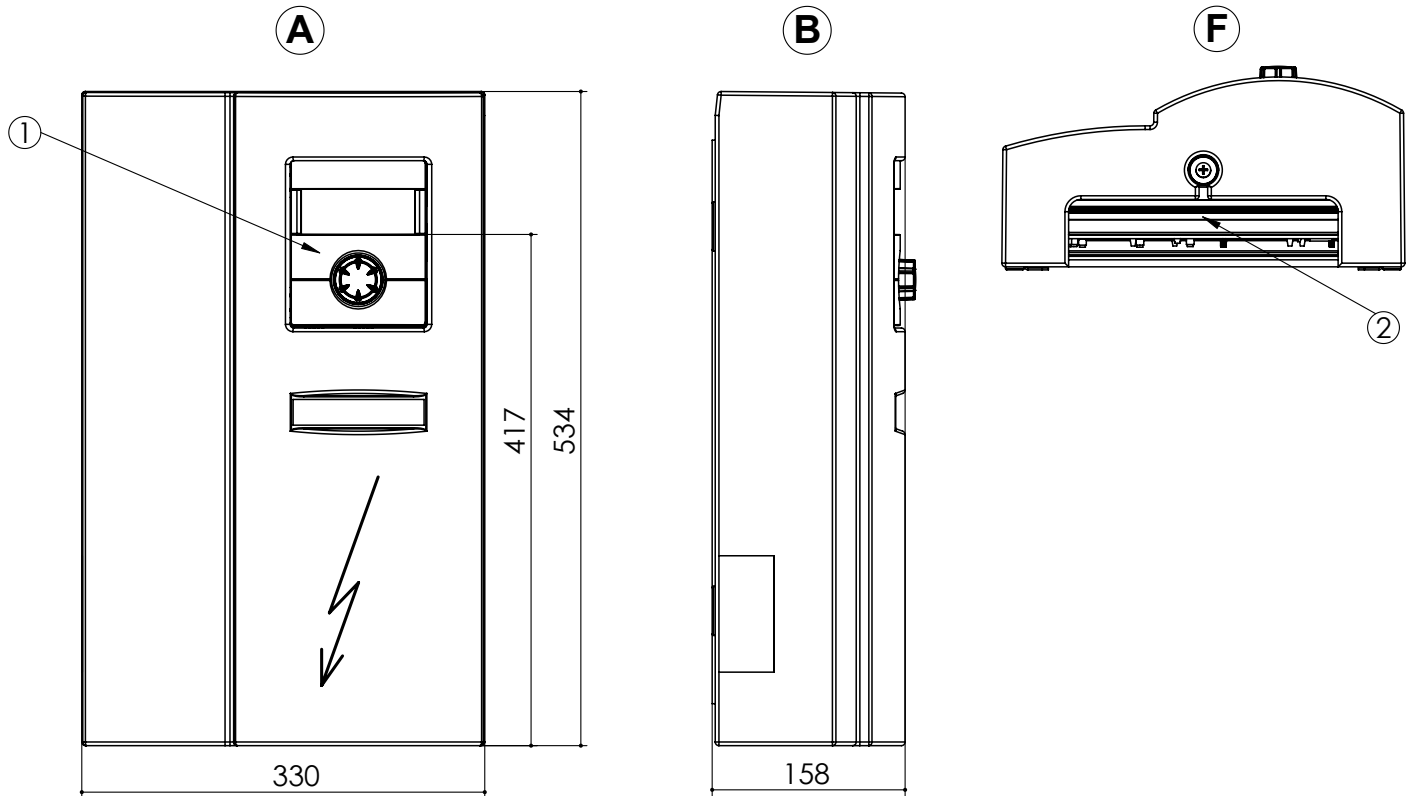

Key: UK819482-
All dimensions in mm.

Pos.	Name
A	Front view
B	Side view from left
F	View from below

Pos.	Name
1	Control panel
2	Feed-through for electric/sensor cables

Drill pattern

Key: UK819494
All dimensions in mm. Spacing for drill pattern.

Pos.	Name
1	Hole Ø6, for wall/floor plugs (accompanying package)

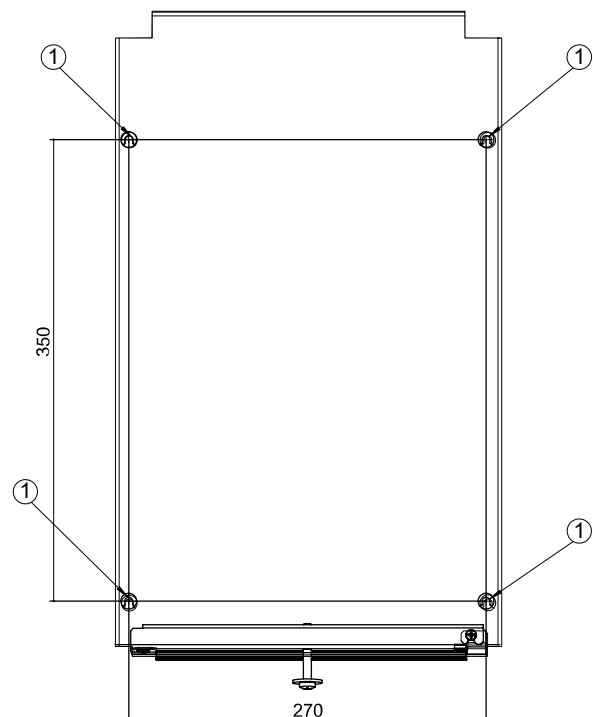

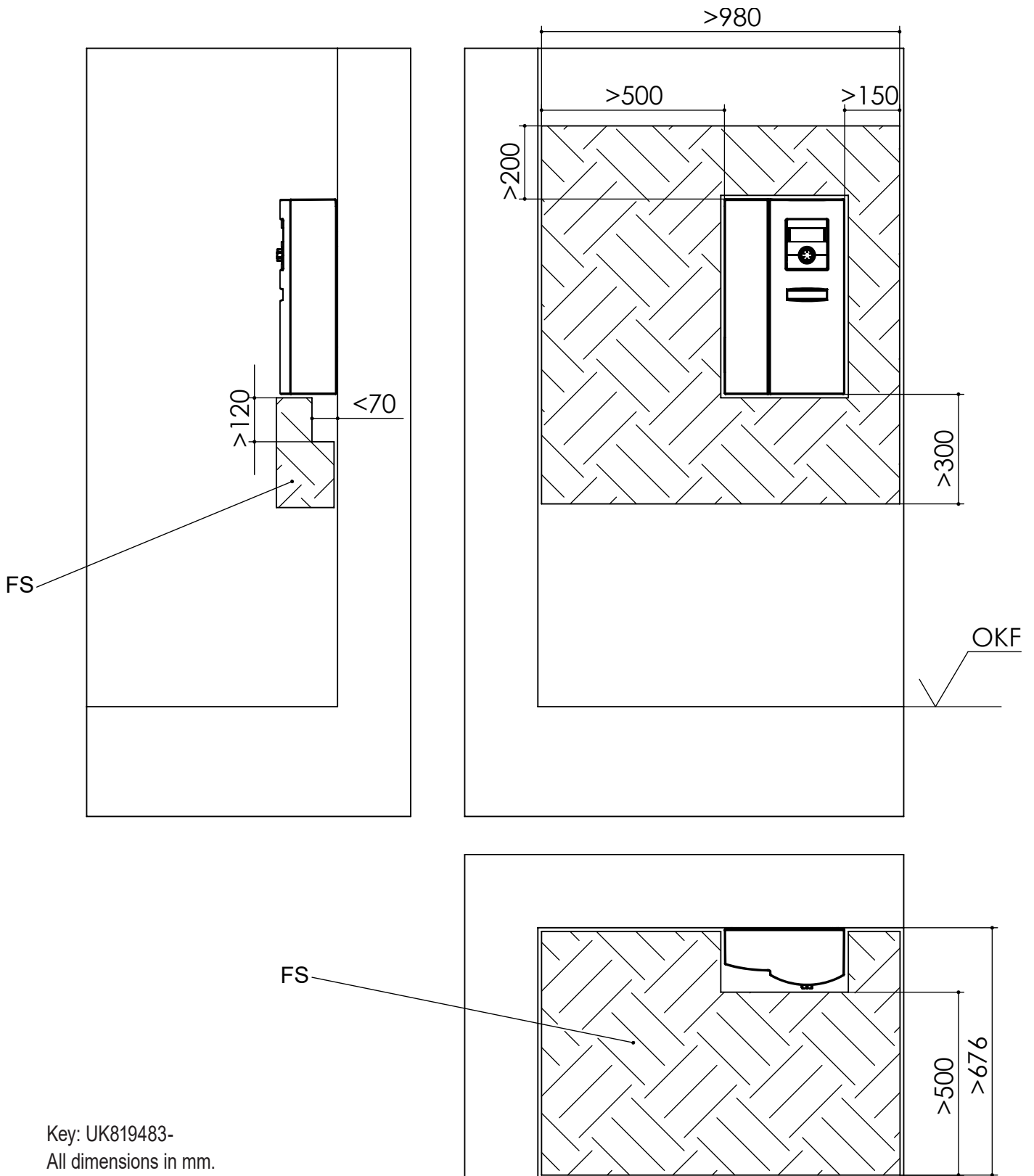

Key: UK819483-
 All dimensions in mm.

Pos.	Name
FS	Free space for service purposes
OKF	Top edge of the finished floor

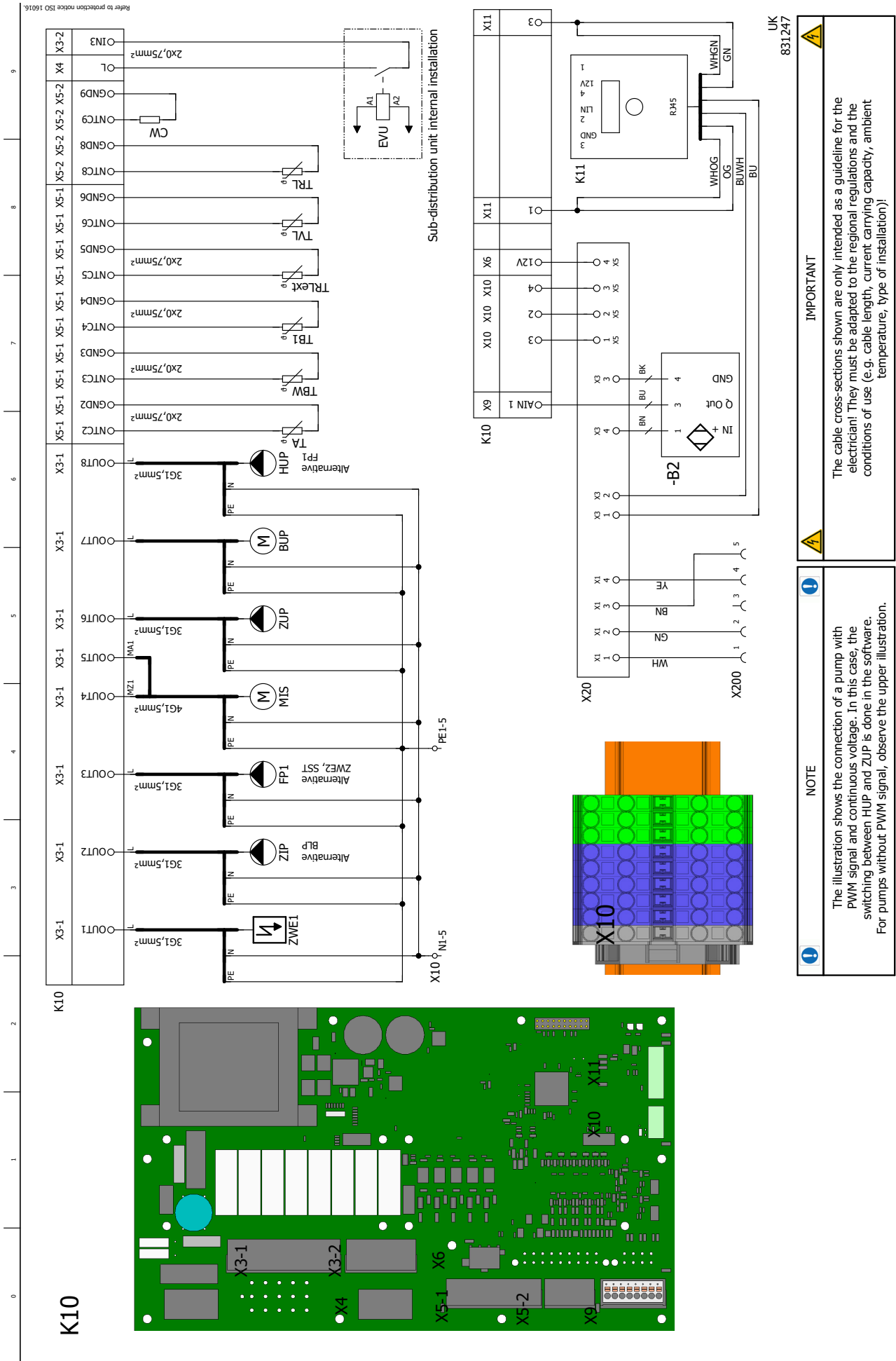



Terminal diagram 2/2

WR 21

Refer to protection notice ISO 16916

Equipment	Description	Wired
PEX	Party external	
TA	Outdoor temperature sensor	
TBW	Domestic hot water temperature sensor / domestic hot water thermostat	
TB1	Temperature sensor, mixing circuit 1	
TRLex:	Temperature sensor, external return	
TVL	Temperature sensor supply	
TRL	Temperature sensor, return	
CW	Coding resistor	X
STB / ZWE	Safety temperature limiter / additional heating generator	
EVU / SG 1	Block by power supply company (jumper if no blocking time) / Smart Grid control 1	X
SG 2	Smart Grid control 2	
ZWE1	Additional heating generator 1	
ZIP / KS / BLP	Domestic hot water circulation pump / cooling signal / domestic hot water charge pump	
FP 1 / ZWE2 / SST	Mixing circuit 1 circulation pump / Additional heating generator 2 / Collective fault	
MIS (MZ1)	Mixing circuit 1 closed (discharge mixer / cooling mixer / charge mixer)	
MIS (MA1)	Mixing circuit 1 open (discharge mixer / cooling mixer / charge mixer)	
ZUP	Additional (feeder) circulation pump	
BUP	Domestic hot water circulation pump / Domestic hot water switching valve	
HUP	Heating circuit circulation pump	X
VBO	Fan / Brine circulation pump / Well circulation pump	
B2	Volumetric flow meter	X
K10	Controller circuit board; Caution: I max = 6.3A/230VAC	X
K11	Control panel	X
X8	Distribution box power supply output compressor	X
X10	Control voltage feed	X
X20	MODBUS circuit board	X
X200	MODBUS	X

UK 831247



Circuit diagram 3/3

WR 21

Refer to protection notice ISO 16016

0 1 2 3 4 5 6 7 8 9

Equipment	Description
B2	Volumetric flow meter
EVU / SG 1	Block by power supply company (jumper if no blocking time) / Smart Grid control 1
K10	Controller circuit board; Caution: I max = 6.3A/230VAC
K11	Control panel
M5	Heating pump
R3	Domestic hot water temperature sensor / domestic hot water thermostat
R4	Temperature sensor, return
R5	Temperature sensor supply
R9	"Encoding resistor; WR27,4kOhm"
WK11-1	Control panel connection cable
WK11-2	Control panel connection cable
X10	Control voltage feed
X20	MODBUS circuit board
X200	MODBUS
XSE	Sensorcard
X5H	Control panel shielding terminal

817492

an ideal tomorrow

The logo for ait Heat Pumps is located in the top right corner. It features the lowercase letters 'ait' in a white, sans-serif font on a dark blue square background. A small blue square is positioned above the 'i'. Below the 'ait' text, the words 'HEAT PUMPS' are written in a smaller, white, uppercase, sans-serif font.

ait-deutschland GmbH
Industriestraße 3
95359 Kasendorf
Germany

T +49 9228 / 99 06 0
F +49 9228 / 99 06 149
E info@ait-deutschland.eu

www.aitgroup.com

Member of NIBE Group.