

Productinformatieblad

Specificaties



Altivar ATS430 softstarter, 17 A, 208 tot 600 V AC, stuurspanning 110 tot 230 V AC, Bypass

ATS430D17S6

EAN Code: 3606486948606

Hoofd

range of product	Altivar Soft Starter ATS430
product or component type	Soft starter
bestemming product	Asynchrone motoren
productspecifieke toepassing	Standard industrial machines
device short name	ATS430
aantal fasen in netwerk	3 fasen
utilisation category	AC-3A AC-53A
Ue power supply voltage	208...600 V AC (- 15...10 %)
power supply frequency	50...60 Hz - 20...20 %
le toegekende bedrijfstrom	Normale werking: 17 A in line (bij <40 °C)
Service factor at le	100
IP-beschermingsgraad	IP20
motorvermogen kW	4 kW bij 230 V in lijn normale werking 7,5 kW bij 400 V in lijn normale werking 7,5 kW bij 440 V in lijn normale werking 9 kW bij 500 V in lijn normale werking 9 kW bij 525 V in lijn normale werking
motorvermogen pk	3 hp bij 208 V normale werking 5 hp bij 230 V normale werking 10 hp bij 460 V normale werking 15 hp bij 575 V normale werking
protocol communicatiepoort	Seriële modbus

Complementair

aansluiting apparaat	In lijn
overbelastingsstroom	400 % Ie for 13 s
on-load factor	50 %
Operating cycles/hour	10 cyc/u
[Us] control circuit voltage	110...230 V AC 50...60 Hz - 15...10 %
schijnbaar vermogen	70 VA
Geïntegreerde beveiliging tegen motoroverbelasting	True
motor thermal protection class	Klasse 10E

De weergegeven prijs is de adviesprijs in euro excl. BTW. Deze kan onderhevig zijn aan korting. Neem contact op met uw lokale distributeur of detailhandel voor de daadwerkelijke prijs

type bescherming	Fase-uitval: mains Thermische beveiliging: mains Thermische beveiliging: starter Stroomoverbelasting: motor Motor underload: motor Excessive acceleration time: motor Motor phase loss detection: motor Protection against line phase inversion: mains External thermal protection: motor Kortsluitingen tussen motorfase en aarding: motor
current limiting %In (5 x Ie maximum)	150...700 %
[In] Rated current pwr loss specifctn	17 A
Aantal door stroommodule gevulde sleuven	19 W
Vermogensverlies per pool afhankelijk van stroom	2 W
Power loss during starting	133 W during starting at 40 °C at 400% In
standards	EN/IEC 60947-4-2 UL 60947-4-2 IEC 60664-1
product certifications	cULus CE UKCA CCC RCM EAC KC
markering	CULus CE UKCA CCC RCM EAC KC
spanning stuurkring	24 V DC
aantal digitale ingangen	4
discreet inputtype	(stop) digital input, 4.4 kOhm (UITVOEREN) digital input, 4.4 kOhm (DI3) digital input, 4.4 kOhm (DI4) digital input, 4.4 kOhm
inputcompatibiliteit	Stop: digitale input niveau 1 PLC conform aan EN/IEC 61131-2 UITVOEREN: digitale input niveau 1 PLC conform aan EN/IEC 61131-2 DI3: digitale input niveau 1 PLC conform aan EN/IEC 61131-2 DI4: digitale input niveau 1 PLC conform aan EN/IEC 61131-2
discrete inputlogica	Digital input stop bij Status 0: 0...< 5 V en <= 2 mA bij Status 1: > 11 V, >= 5 mA Digital input UITVOEREN bij Status 0: 0...< 5 V en <= 2 mA bij Status 1: > 11 V, >= 5 mA Digital input DI3 bij Status 0: 0...< 5 V en <= 2 mA bij Status 1: > 11 V, >= 5 mA Digital input DI4 bij Status 0: 0...< 5 V en <= 2 mA bij Status 1: > 11 V, >= 5 mA
relaisuitgang nummer	2
relaisuitgang type	Relaisoutputs R1A, R1C NO Relaisoutputs R1B, R1C NC Relaisoutputs R2A, R2C NO
minimale schakelstroom	100 mA bij 12 V DC voor relais outputs
maximale schakelstroom	Relaisoutputs 2 A / 250 V AC for AC-15 100000 cycles following IEC 60947-5-1 Relaisoutputs 2 A / 30 V DC for DC-13 150000 cycles following IEC 60947-5-1
aantal analoge ingangen	1
analoog inputtype	PTC1 : PTC temperature probe PTC2 : PTC temperature probe
aantal analoge uitgangen	1

analoog outputtype	Huidige output AQ1 : 0...20 mA / 4...20 mA , impedance < 500 Ohm Spanningsuitgang AQ1 : 0...10 V , impedance > 470 Ohm
protocol communicatiepoort	Seriële modbus RJ45 Seriële modbus open style (DO, D1, PE, COM)
type connector	1 RJ45 Open style
fysieke interface	2-draads RS485 - stekker(s): RJ45 2-draads RS485 - stekker(s): open style (DO, D1, PE, COM)
transmissieframe	RTU : 1 RJ45 RTU : open style (DO, D1, PE, COM)
transmissiesnelheid	4.8...38.4 kbps for seriële modbus RJ45 0.3...115.2 kbps for seriële modbus open style (DO, D1, PE, COM)
gegevensformaat	8 bits, odd, even or no parity, 1 or 2 bits to stop for seriële modbus RJ45 8 bits, configureerbaar oneven, even of geen pariteit for seriële modbus open style (DO, D1, PE, COM)
aantal adressen	0...247 voor seriële modbus
toegangsmethode	Slave seriële modbus
type polarisatie	Geen impedantie voor seriële modbus
Beschikbaar display	True
werkingspositie	Vertikaal +/- 10 graden
height	273 mm
width	130 mm
depth	169 mm
net weight	2,90 kg
interne bypass	True
beschikbarefunctie	Enkele richting Voorverwarming Power monitoring Condition monitoring Gebruikersbeheer Havens en services verharding Registratie veiligheidsgebeurtenissen Cyberveilige firmware-update Small motor test
materiaalaangifte	True

Omgeving

elektromagnetische compatibiliteit	Geleide en uitgestraalde emissies niveau A conforming to IEC 60947-4-2 Gedempte oscillerende golven level 3 conforming to IEC 61000-4-18 Elektrostatische ontlading level 3 conforming to IEC 61000-4-2 Immunititeit voor elektrische transiënten level 4 conforming to IEC 61000-4-4 Immunititeit voor gestraalde radio-elektrische interferentie level 3 conforming to IEC 61000-4-3 Spanning/stroomimpuls level 3 conforming to IEC 61000-4-5 Immunity to conducted disturbances radio-frequency level 3 conforming to IEC 61000-4-6
pollution degree	Niveau 3
[Uimp] rated impulse withstand voltage	6 kV
[Ui] rated insulation voltage	600 V
Omgevingsklasse (tijdens werking)	Klasse 3C3 volgens IEC 60721-3-3 Klasse 3S3 volgens IEC 60721-3-3
omgevingsluchttemperatuur voor werking	-25...40 °C (zonderverlies) 40...60 °C (with current derating of 1 % per °C above 40 °C)

ambient air temperature for storage	-40...70 °C
Analoge uitgangsstroom	-40...70 °C
bedrijfshoogte	<= 2000 m zonderverlies > 2000...4800 m with current derating 1 % per 100 m above 2000 m
relatieve vochtigheid	5...95 % zonder condensatie of waterdruppels conform aan EN/IEC 60068-2-3
Maximale vervorming onder trillende belasting (tijdens werking)	1,5 mm bij 2...13 Hz
Maximale vervorming onder trillende belasting (tijdens opslag)	1,75 mm bij 2...9 Hz
Maximale doorbuiging onder trillende belasting (tijdens transport)	1,75 mm bij 2...9 Hz
Maximale versnelling onder trillingsspanning (tijdens werking)	1 gn at 13...200 Hz
Maximale versnelling onder trillende belasting (tijdens opslag)	1 gn at 9...200 Hz 1.5 gn at 200...500 Hz
Maximale versnelling onder trillende belasting (tijdens transport)	1 gn at 9...200 Hz 1.5 gn at 200...500 Hz
Maximale versnelling bij schok (tijdens bedrijf)	15 gn at 11 ms
Maximale versnelling onder schokbelasting (tijdens opslag)	10 gn at 11 ms
Maximale versnelling onder schokbelasting (tijdens transport)	10 gn at 11 ms

Verpakkingseenheid

Unit Type of Package 1	PCE
Number of Units in Package 1	1
Package 1 Height	22,500 cm
Package 1 Width	24,000 cm
Package 1 Length	34,500 cm
Package 1 Weight	4,018 kg
Unit Type of Package 2	S06
Number of Units in Package 2	10
Package 2 Height	75,000 cm
Package 2 Width	60,000 cm
Package 2 Length	80,000 cm
Package 2 Weight	48,600 kg

Environmental Data

Schneider Electric wil tegen 2050 de Net Zero-status hebben bereikt via partnerschappen in de toeleveringsketen, materialen met een lagere impact en circulariteit via onze doorlopende campagne "Use Better, Use Longer, Use Again" om de levensduur van producten en de recycleerbaarheid te verlengen.

[Uitleg van Environmental Data](#) >

[Hoe evalueren we de duurzaamheid van producten?](#) >

Milieuvoetafdruk

Totale levenscyclus ecologische voetafdruk 2139

Milieuprofiel van product (PEP) [Milieuprofiel van het product](#)

Use Better

Materialen en verpakking

Pakket met gerecycleerd karton Nee

Verpakkingen zonder kunststof Nee

EU-richtlijn RoHS Voldoet niet

SCIP-nummer 6d50853e-11c9-49b4-b4cf-9b6edb1894b1

REACH-regelgeving [REACH-verklaring](#)

Use Again

Herverpakken en herfabriceren

Circulair Profiel [Informatie over einde levensduur](#)

Terugname No

WEEE Label  Het product moet op markten van de Europese Unie worden afgevoerd volgens specifieke afvalinzamelingsregels en mag nooit in een gewone vuilnisbak terechtkomen.

Dimensions Drawings

Dimensions

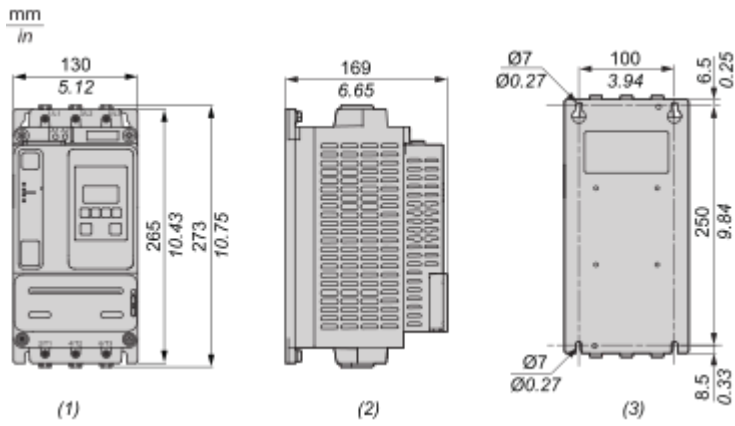

- (1) : Front
- (2) : Side
- (3) : Rear

Mounting and Clearance

Mounting Position

The soft starter is designed to be mounted inside cabinets vertically at $\pm 10^\circ$ for cooling purposes. Respect the minimum clearances so that the cooling air can circulate from the bottom to the top of the soft starter. The minimum clearances apply to any device close to the soft starter such as circuit breakers, fuses and contactors. Do not install the soft starter above heating elements.

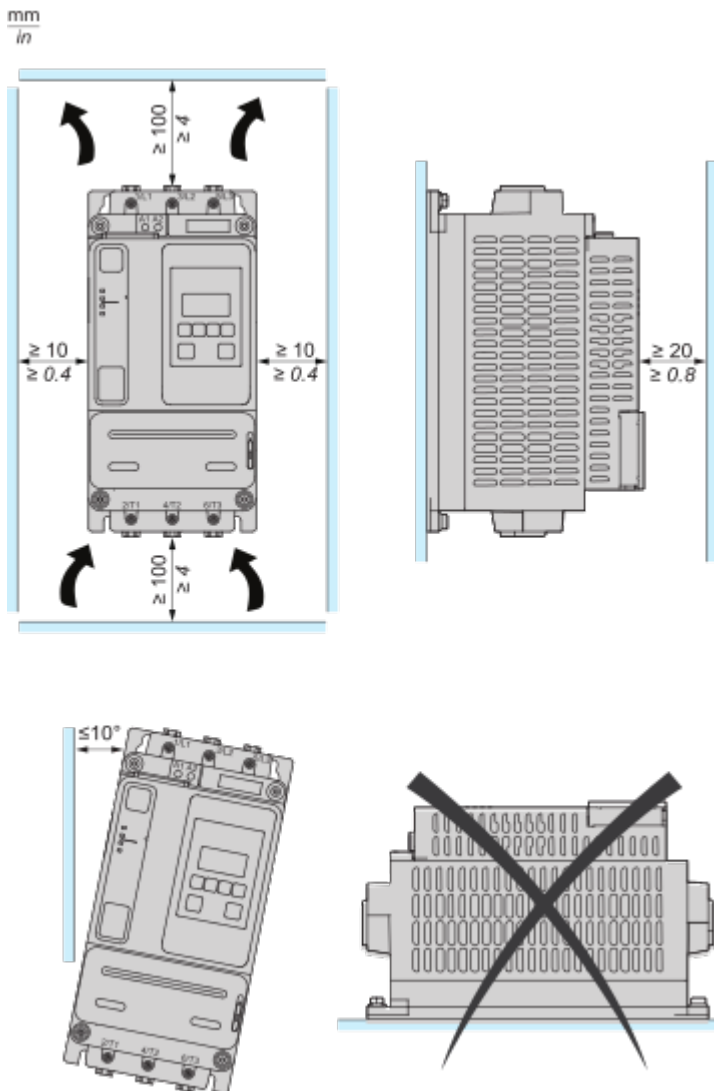

Connections and Schema

Wiring

Wiring the Power Part

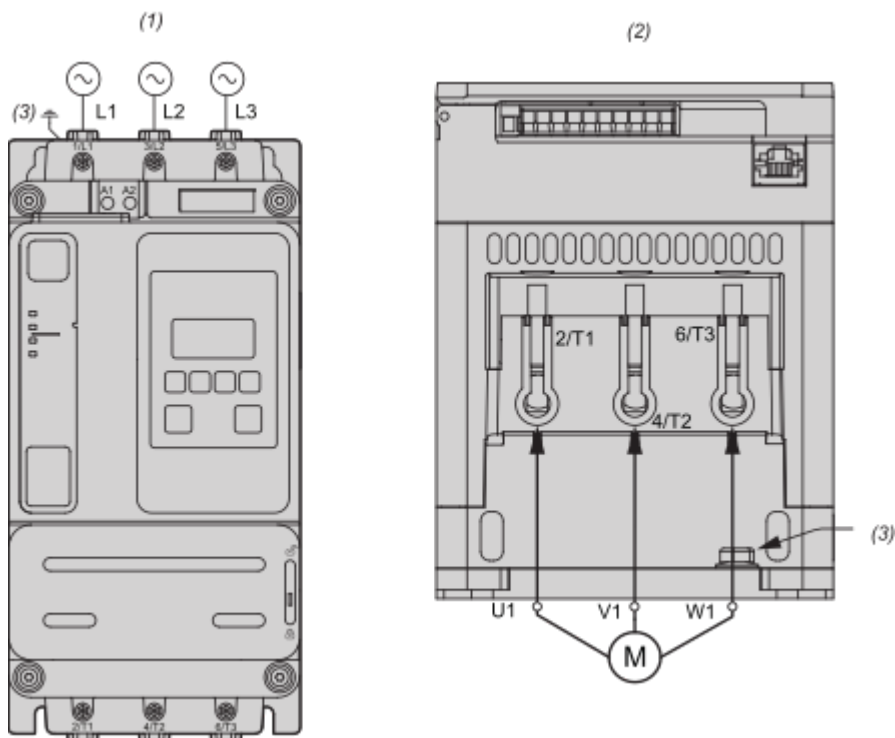

Use class C cables for the power connections.

1/L1, 3/L2, 5/L3 : Mains supply inputs

2/T1, 4/T2, 6/T3 : Outputs to motor

(1) : Mains side

(2) : Motor side (bottom)

(3) : Ground connection

Connection In Line, With Line Contactor, Type 1 or 2 Coordination, 2-wire control or 3-wire control

Line contactor controlled based on RUN & STOP or on detected error.

Use relay output R1 set to [Mains Contactor]

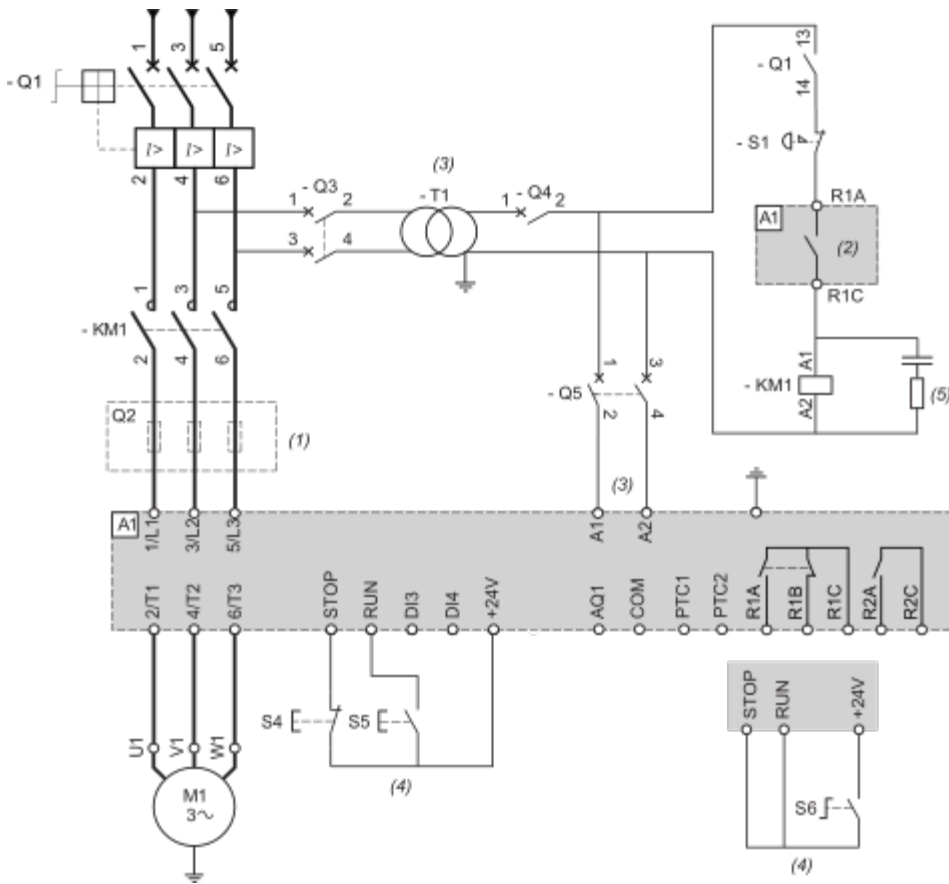

- (1) : Installation of additional fast-acting fuses is mandatory to upgrade to type 2 coordination according to IEC 60947-4-2.
- (2) : Take into account the electrical characteristics of the relays.
- (3) : The transformer must supply 110...230 Vac -15%...+10%, 50/60Hz.
- (4) : 3-wire control or 2-wire control.
- (5) : Select the appropriate voltage surge suppressor.

Designation	Component	Description
Q1	Circuit breaker	Short circuit protection device for the motor
Q2	Circuit breaker	Short circuit protection device for the primary of the transformer
Q3	Fast acting fuses	Short circuit protection device of the soft starter to be used only when type 2 coordination according to IEC 60947-4-2 is required
Q4	Circuit breaker	Short circuit protection device for the secondary of the transformer
Q5	Circuit breaker	Short circuit protection device for the control part of the soft starter
KM1	Contactor	Line contactor
S1	Emergency Stop push-button	Emergency Stop to de-energized KM1 line contactor
S4	Normally close contact push-button	STOP command for 3-wire control

S5	Normally open contact push-button	RUN command for 3-wire control
S6	Selector switch, 2 positions, stay-put, normally open contact	RUN/STOP. command for 2-wire control

Connection In Line, With Line Contactor, Type 1 or 2 Coordination, 2-wire or 3-wire

Line contactor controlled by Power ON and Power OFF push-buttons or detected error.

Use relay output R1 set to [Operating State Fault] (factory setting)

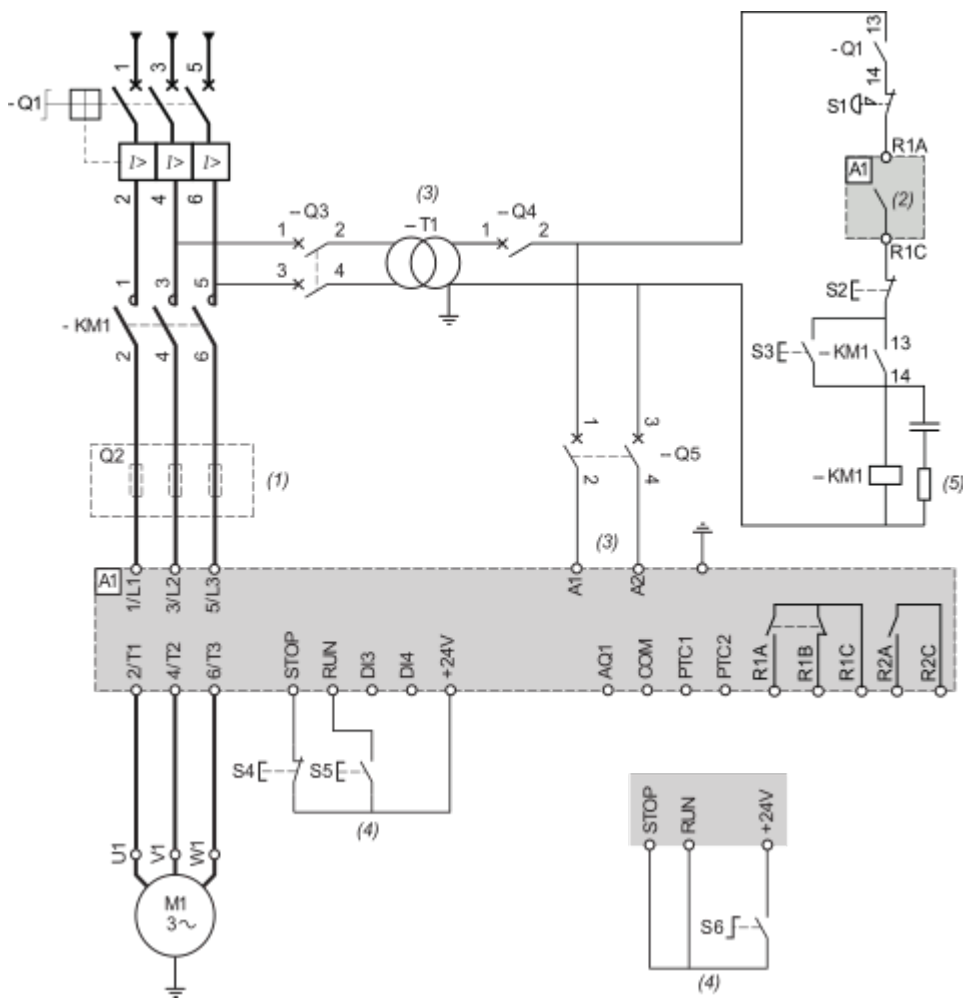

- (1) : Installation of additional fast-acting fuses is mandatory to upgrade to type 2 coordination according to IEC 60947-4-2.
- (2) : Take into account the electrical characteristics of the relays.
- (3) : The transformer must supply 110...230 Vac -15%...+10%, 50/60Hz.
- (4) : 3-wire control and 2-wire control.
- (5) : Select the appropriate voltage surge suppressor.

Designation	Component	Description
Q1	Circuit breaker	Short circuit protection device for the motor
Q2	Circuit breaker	Short circuit protection device for the primary of the transformer
Q3	Fast acting fuses	Short circuit protection device of the soft starter to be used only when type 2 coordination

Q4	Circuit breaker	Short circuit protection device for the secondary of the transformer
Q5	Circuit breaker	Short circuit protection device for the control part of the soft starter
KM1	Contacteur	Line contactor
S1	Emergency Stop push-button	Emergency Stop to de-energized KM1 line contactor
S2	Normally close push-button	Power OFF
S3	Normally open push-button	Power ON
S4	Normally close contact push-button	STOP command for 3-wire control
S5	Normally open contact push-button	RUN command for 3-wire control
S6	Selector switch, 2 positions, stay-put, normally open contact	RUN/STOP command for 2-wire control

Control Block Wiring Diagram

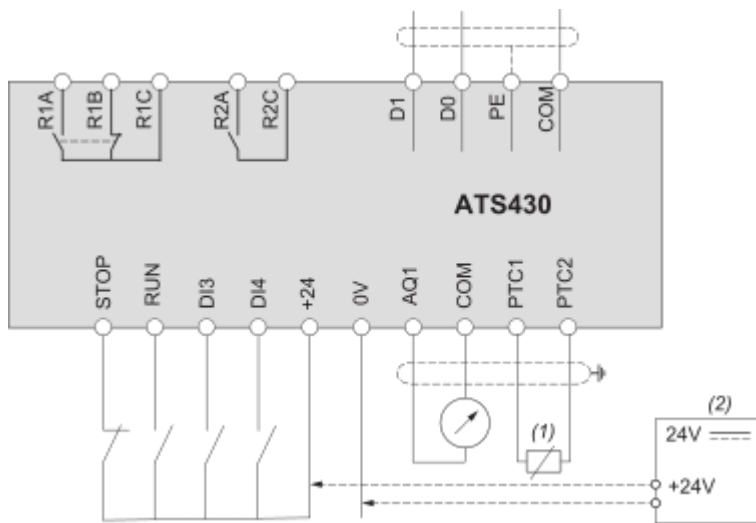

- R1A, R1B, R1C : Programmable relay R1
- R2A, R2C : Relay assigned to End of starting
- STOP, RUN, DI3, DI4 : Digital inputs
- AQ1: Analogue output
- PTC1, PTC2 : PTC connection
- D0, D1 : Serial link based on 2-wire Modbus over serial line electrical interface
- (1) : 2 wire PTC
- (2) : Optional, in case of +24 External Supply usage

Technical Illustration

Dimensions

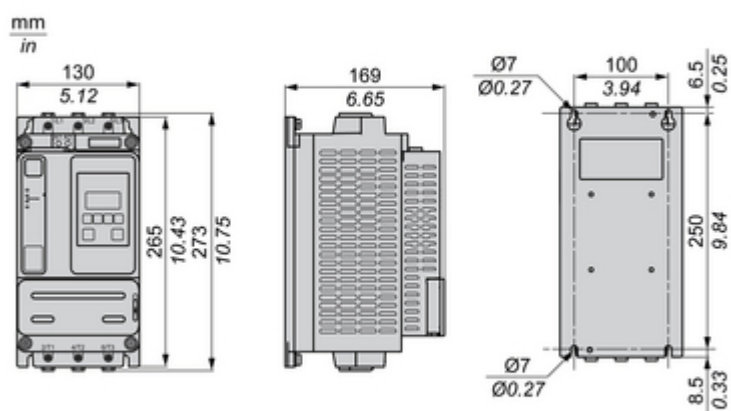

Technical Illustration

Wiring diagram

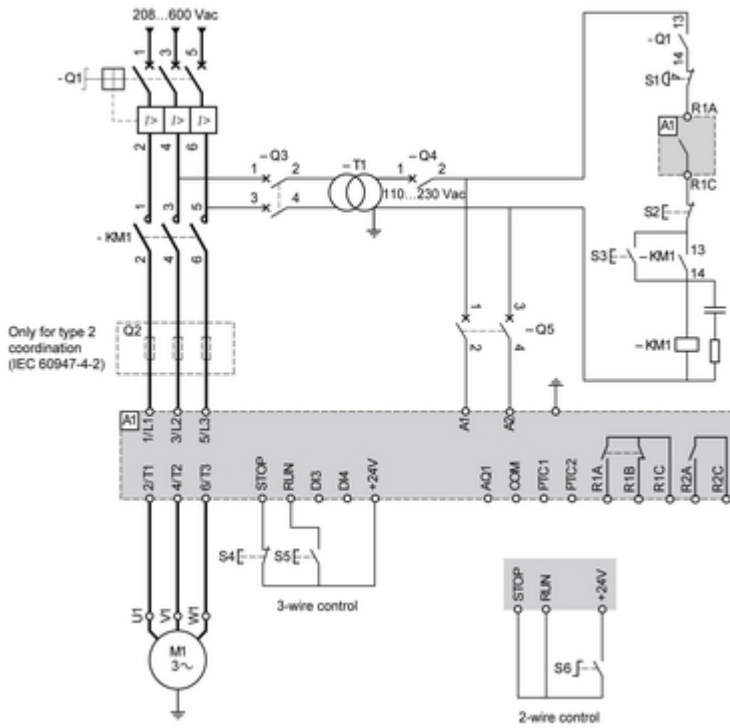

Image of product / Alternate images

Alternative





