

Productinformatieblad

Specificaties



Altivar ATS490 softstarter, 62 A, 208 tot 690 V AC, stuurspanning 110 tot 230 V AC, Bypass, STO

ATS490D62Y

EAN Code: 3606486948804

Hoofd

range of product	Altivar Soft Starter ATS490
product or component type	Soft starter
bestemming product	Asynchrone motoren
productspecifieke toepassing	Processen en infrastructuur
device short name	ATS490
aantal fasen in netwerk	3 fasen
utilisation category	AC-3A AC-53A
Ue power supply voltage	208...690 V AC (- 15...10 %)
power supply frequency	50...60 Hz - 20...20 %
le toegekende bedrijfstrom	Normale werking: 62 A in line (bij <40 °C)
Service factor at le	100
rated current in heavy duty	47 A at 40 °C voor heavy duty
IP-beschermingsgraad	IP20
motorvermogen kW	15 kW bij 230 V op de voedingslijn van de motor normale werking 30 kW bij 400 V op de voedingslijn van de motor normale werking 30 kW bij 440 V op de voedingslijn van de motor normale werking 37 kW bij 500 V op de voedingslijn van de motor normale werking 37 kW bij 525 V op de voedingslijn van de motor normale werking 45 kW bij 660 V op de voedingslijn van de motor normale werking 45 kW bij 690 V op de voedingslijn van de motor normale werking 11 kW bij 230 V op de voedingslijn van de motor heavy duty 22 kW bij 400 V op de voedingslijn van de motor heavy duty 22 kW bij 440 V op de voedingslijn van de motor heavy duty 30 kW bij 500 V op de voedingslijn van de motor heavy duty 30 kW bij 525 V op de voedingslijn van de motor heavy duty 37 kW bij 660 V op de voedingslijn van de motor heavy duty 37 kW bij 690 V op de voedingslijn van de motor heavy duty 30 kW bij 230 V op de delta-terminals van de motor normale werking 55 kW bij 400 V op de delta-terminals van de motor normale werking 22 kW bij 230 V op de delta-terminals van de motor heavy duty 45 kW bij 400 V op de delta-terminals van de motor heavy duty
motorvermogen pk	15 hp bij 208 V normale werking 20 hp bij 230 V normale werking 40 hp bij 460 V normale werking 50 hp bij 575 V normale werking 15 hp bij 230 V heavy duty 30 hp bij 460 V heavy duty 40 hp bij 575 V heavy duty
Met veiligheidsfunctie Veilige koppeluitschakeling (STO)	True
Safe Torque Off (STO)	STO (safe torque off): SIL 1 conforming to IEC 61508 STO (safe torque off): PL c/category 2 conforming to ISO 13849
Cybersecurity functions	True

De weergegeven prijs is de adviesprijs in euro excl. BTW. Deze kan onderhevig zijn aan korting. Neem contact op met uw lokale distributeur of detailhandel voor de daadwerkelijke prijs

Cybersecurity level and standard	Security level (SL) 1 conform aan IEC 62443-4-2
protocol communicatiepoort	Seriële modbus Modbus TCP/EtherNet/IP
optiekaart	Communicatiemodule voor CANopen doorlussen Communicatiemodule voor CANopen SUB-D Communicatiemodule voor CANopen open stijl Communicatiemodule voor Profibus DP V1 Communicatiemodule voor Profinet

Complementair

aansluiting apparaat	Op de voedingslijn van de motor Inside delta
Overload current profile	400 % I _e for 13 s
on-load factor	50 %
Operating cycles/hour	10 cyc/u
[Us] control circuit voltage	110...230 V AC 50...60 Hz - 15...10 %
schijnbaar vermogen	70 VA
Geïntegreerde beveiliging tegen motoroverbelasting	True
motor thermal protection class	Klasse 10E
type bescherming	Fase-uitval: mains Thermische beveiliging: starter Thermische beveiliging: motor Stroomoverbelasting: motor Motor underload: motor Excessive acceleration time: motor Motor phase loss detection: motor Protection against line phase inversion: mains External thermal protection: motor Protection delta inside wiring: starter Kortsluitingen tussen motorfase en aarding: motor
current limiting %I_n (5 x I_e maximum)	150...700 %
[In] Rated current pwr loss specifctn	62 A
Aantal door stroommodule gevulde sleuven	19 W
Vermogensverlies per pool afhankelijk van stroom	7 W
Power loss during starting	675 W during starting at 40 °C at 400% I _e
standards	EN/IEC 60947-4-2 UL 60947-4-2 IEC 60664-1
product certifications	CE cULus UKCA RCM CCC DNV ATEX EAC KC
markering	CE CULus UKCA RCM CCC ATEX EAC KC
spanning stuurkring	24 V DC

aantal digitale ingangen	5
discreet inputtype	(DI1) digital input, 4.4 kOhm (DI2) digital input, 4.4 kOhm (DI3) digital input, 4.4 kOhm (DI4) digital input, 4.4 kOhm (STO) digital input, > 1 kOhm
inputcompatibiliteit	DI1: discrete input niveau 1 PLC conform aan EN/IEC 61131-2 DI2: discrete input niveau 1 PLC conform aan EN/IEC 61131-2 DI3: discrete input niveau 1 PLC conform aan EN/IEC 61131-2 DI4: discrete input niveau 1 PLC conform aan EN/IEC 61131-2 STO: discrete input niveau 1 PLC conform aan EN/IEC 61131-2
discrete inputlogica	Digital input DI1 bij Status 0: 0...< 5 V en <= 2 mA bij Status 1: > 11 V, >= 5 mA Digital input DI2 bij Status 0: 0...< 5 V en <= 2 mA bij Status 1: > 11 V, >= 5 mA Digital input DI3 bij Status 0: 0...< 5 V en <= 2 mA bij Status 1: > 11 V, >= 5 mA Digital input DI4 bij Status 0: 0...< 5 V en <= 2 mA bij Status 1: > 11 V, >= 5 mA Digital input STO bij Status 0: 0...< 5 V en <= 2 mA bij Status 1: > 11 V, >= 5 mA
relaisuitgang nummer	3
relaisuitgang type	Relaisoutputs R1A, R1C NO Relaisoutputs R2A, R2C NO Relaisoutputs R3A, R3C NO
minimale schakelstroom	100 mA bij 12 V DC voor relais outputs
maximale schakelstroom	Relaisoutputs 2 A / 250 V AC for AC-15 100000 cycles following IEC 60947-5-1 Relaisoutputs 2 A / 30 V DC for DC-13 150000 cycles following IEC 60947-5-1
aantal digitale uitgangen	2
discreet uitgangstype	Programmeerbare digitale uitgang DQ1 <= 30 V 100 mA Programmeerbare digitale uitgang DQ2 <= 30 V 100 mA
Uitgangscompatibiliteit	Open collector niveau 1 PLC conform aan IEC 65A-68
aantal analoge ingangen	1
analoog inputtype	AI1/PTC1 : PTC/PT 100/PT 1000/KTY84 temperature probe PTC2 : PTC/PT 100/PT 1000/KTY84 temperature probe PTC3 : PTC/PT 100/PT 1000/KTY84 temperature probe
aantal analoge uitgangen	1
analoog outputtype	Huidige output AQ1 : 0...20 mA / 4...20 mA , impedance< 500 Ohm Spanningsuitgang AQ1 : 0...10 V , impedance> 470 Ohm
protocol communicatiepoort	Seriële modbus Modbus TCP/EtherNet/IP
type connector	1 RJ45 for connecting Modbus serial 1 RJ45 for connecting Modbus TCP/EtherNet/IP
fysieke interface	2-draads RS485 100-BASE-TX category 5 or industrial Ethernet
transmissieframe	RTU TCP/UDP
transmissiesnelheid	4.8...38.4 kbps 100 BASE TX
dataformaat	8 bits, configurable odd, even or no parity 1or 2 stop
aantal adressen	0...247 voor seriële modbus
toegangsmethode	Slave seriële modbus
type polarisatie	Geen impedantie voor seriële modbus
Beschikbaar display	True
werkingspositie	Vertikaal +/- 10 graden
height	289 mm
width	160 mm

depth	234 mm
net weight	7 kg
interne bypass	True
beschikbarefunctie	Voorverwarming Rook-extractie Tweede motorset Deceleration with torque control Braking Boost Line contactor control Reverse contactor control Anti-jam Jog Borehole pump starting Condition monitoring Power monitoring Cyberveilige firmware-update
materiaalaangifte	True

Omgeving

elektromagnetische compatibiliteit	Geleide en uitgestraalde emissies niveau A conforming to IEC 60947-4-2 Gedempte oscillerende golven level 3 conforming to IEC 61000-4-18 Elektrostatische ontlading level 3 conforming to IEC 61000-4-2 Immunititeit voor elektrische transiënten level 4 conforming to IEC 61000-4-4 Immunititeit voor gestraalde radio-elektrische interferentie level 3 conforming to IEC 61000-4-3 Spanning/stroomimpuls level 3 conforming to IEC 61000-4-5 Immunititeit voor geleide interferentie, geïnduceerd doorradio-elektrische velden level 3 conforming to EN/IEC 61000-4-6
pollution degree	Niveau 3
[Uimp] rated impulse withstand voltage	6 kV
[Ui] rated insulation voltage	690 V
Omgevingsklasse (tijdens werking)	Klasse 3C3 volgens IEC 60721-3-3 Klasse 3S3 volgens IEC 60721-3-3
omgevingsluchttemperatuur voor werking	-25...40 °C (zonderverlies) 40...60 °C (with current derating of 1 % per °C above 40 °C)
ambient air temperature for storage	-40...70 °C
Analoge uitgangsstroom	-40...70 °C
bedrijfshoogte	<= 2000 m zonderverlies > 2000...4800 m with current derating 1 % per 100 m above 2000 m
relatieve vochtigheid	5...95 % zonder condensatie of waterdruppels conform aan EN/IEC 60068-2-3
Maximale vervorming onder trillende belasting (tijdens werking)	1,5 mm bij 2...13 Hz
Maximale vervorming onder trillende belasting (tijdens opslag)	1,75 mm bij 2...9 Hz
Maximale doorbuiging onder trillende belasting (tijdens transport)	1,75 mm bij 2...9 Hz
Maximale versnelling onder trillingsspanning (tijdens werking)	1 gn at 13...200 Hz
Maximale versnelling onder trillende belasting (tijdens opslag)	1 gn at 9...200 Hz 1.5 gn at 200...500 Hz
Maximale versnelling onder trillende belasting (tijdens transport)	1 gn at 9...200 Hz 1.5 gn at 200...500 Hz
Maximale versnelling bij schok (tijdens bedrijf)	15 gn at 11 ms
Maximale versnelling onder schokbelasting (tijdens opslag)	10 gn at 11 ms

Maximale versnelling onder
schokbelasting (tijdens transport) 10 gn at 11 ms

Verpakkingseenheid

Unit Type of Package 1	PCE
------------------------	-----

Number of Units in Package 1	1
------------------------------	---

Package 1 Height	23,900 cm
------------------	-----------

Package 1 Width	28,500 cm
-----------------	-----------

Package 1 Length	36,400 cm
------------------	-----------

Package 1 Weight	8,352 kg
------------------	----------

Unit Type of Package 2	S06
------------------------	-----

Number of Units in Package 2	8
------------------------------	---

Package 2 Height	73,000 cm
------------------	-----------

Package 2 Width	60,000 cm
-----------------	-----------

Package 2 Length	80,000 cm
------------------	-----------

Package 2 Weight	79,400 kg
------------------	-----------

Schneider Electric wil tegen 2050 de Net Zero-status hebben bereikt via partnerschappen in de toeleveringsketen, materialen met een lagere impact en circulariteit via onze doorlopende campagne "Use Better, Use Longer, Use Again" om de levensduur van producten en de recycleerbaarheid te verlengen.

[Uitleg van Environmental Data](#) >

[Hoe evalueren we de duurzaamheid van producten?](#) >

Milieuoetafdruk

Totale levenscyclus ecologische voetafdruk **1014**

Milieuprofiel van product (PEP) [Milieuprofiel van het product](#)

Use Better

Materialen en verpakking

Pakket met gerecycleerd karton **Ja**

Verpakkingen zonder kunststof **Nee**

[EU-richtlijn RoHS](#) **Voldoet aan vrijstellingen**

SCIP-nummer **32653a5f-3d43-47fe-ac6f-9f8f40dfeff0**

REACH-regelgeving [REACH-verklaring](#)

PVC-vrij **Ja**

Use Again

Herverpakken en herfabriceren

Circulair Profiel [Informatie over einde levensduur](#)

Terugname **No**

WEEE Label  **Het product moet op markten van de Europese Unie worden afgevoerd volgens specifieke afvalinzamelingsregels en mag nooit in een gewone vuilnisbak terechtkomen.**

Dimensions Drawings

Dimensions

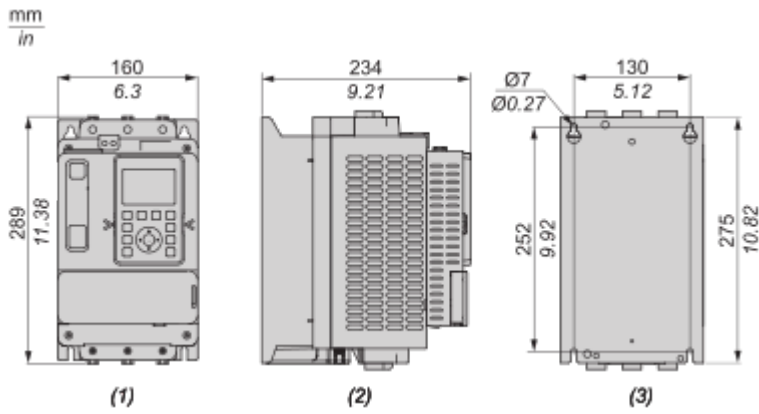

- (1) : Front
- (2) : Side
- (3) : Rear

Mounting and Clearance

Mounting Position

The soft starter is designed to be mounted inside cabinets vertically at $\pm 10^\circ$ for cooling purposes. Respect the minimum clearances so that the cooling air can circulate from the bottom to the top of the soft starter. The minimum clearances apply to any device close to the soft starter such as circuit breakers, fuses and contactors. Do not install the soft starter above heating elements.

mm
in

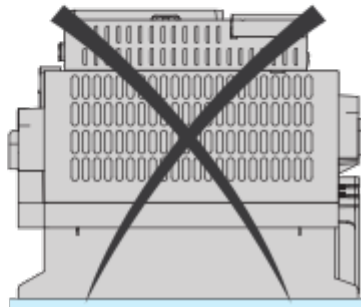
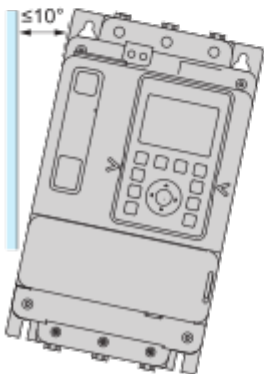
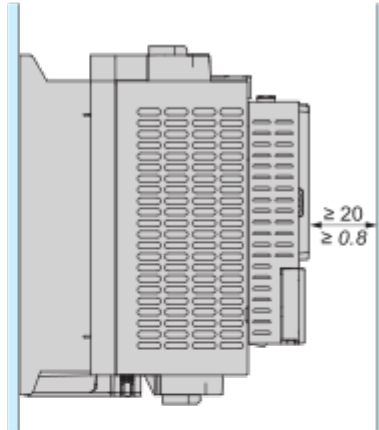
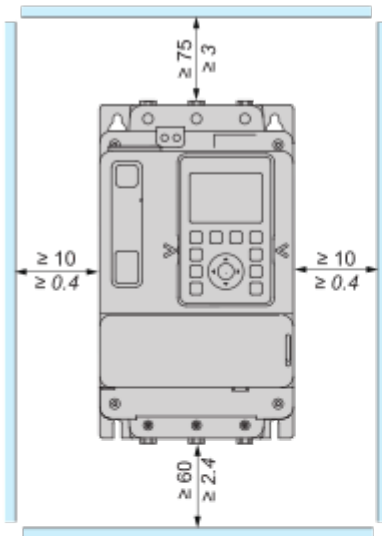

Connections and Schema

Wiring

Wiring the Power Part

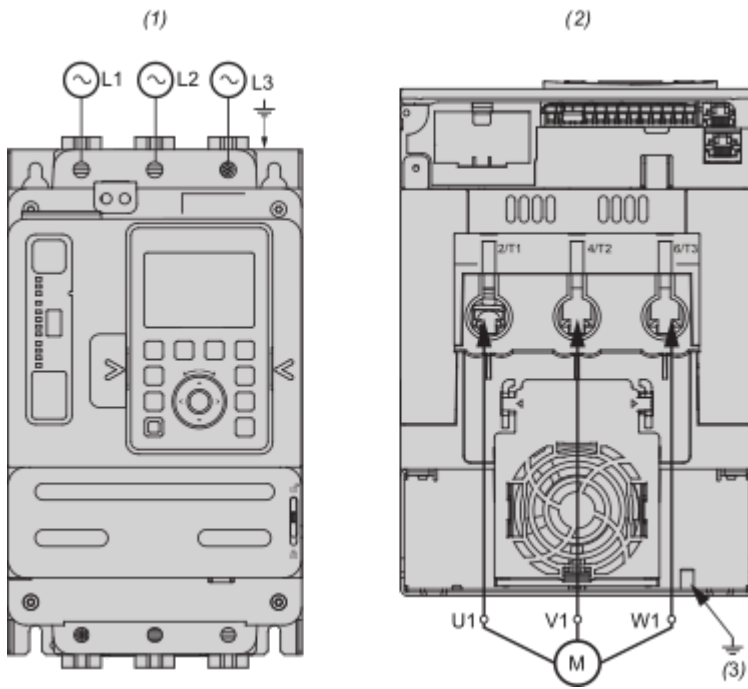

Use class C cables for the power connections.

1/L1, 3/L2, 5/L3 : Mains supply inputs

2/T1, 4/T2, 6/T3 : Outputs to motor

(1) : Mains side

(2) : Motor side (bottom)

(3) : Ground connection

Connection In Line, No Line Contactor, Type 1 or 2 Coordination, 2-wire or 3-wire control

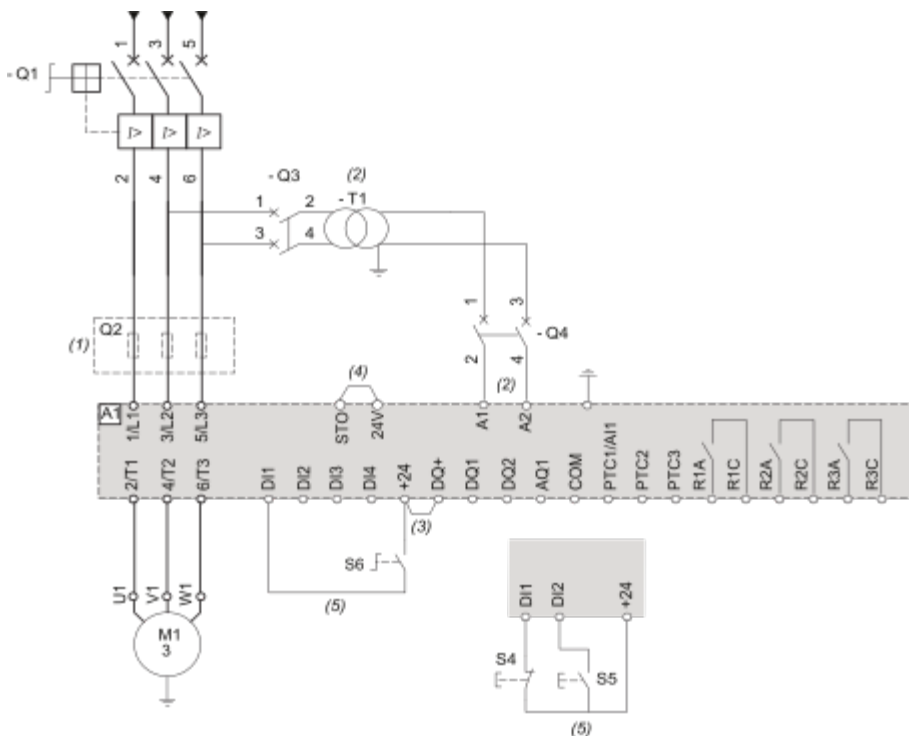

- (1) : Installation of additional fast-acting fuses is mandatory to upgrade to type 2 coordination according to IEC 60947-4-2.
- (2) : The transformer must supply 110...230 Vac +10% - 15%, 50/60Hz.
- (3) : 24Vdc supply on DQ+ if usage of DQ outputs.
- (4) : STO Safe Torque Off
- (5) : 3-wire control and 2-wire control.

Designation	Component	Description
Q1	Circuit breaker	Short circuit protection device for the motor
Q2	Fast acting fuses	Short circuit protection device of the soft starter to be used only when type 2 coordination
Q3	Circuit breaker	Short circuit protection device for the primary of the transformer
Q4	Circuit breaker	Short circuit protection device for the secondary of the transformer
S4	Normally close contact push- button	STOP command for 3-wire control
S5	Normally open contact push- button	RUN command for 3-wire control
S6	Selector switch, 2 positions, stay-put, normally open contact	RUN/STOP command for 2-wire control

Connection In Line, With Line Contactor, Type 1 or 2 Coordination, 2-wire or 3-wire control

Line contactor controlled by Power ON and Power OFF push-buttons or on detected error

Use relay output R1 set to [Operating State Fault] (factory setting)

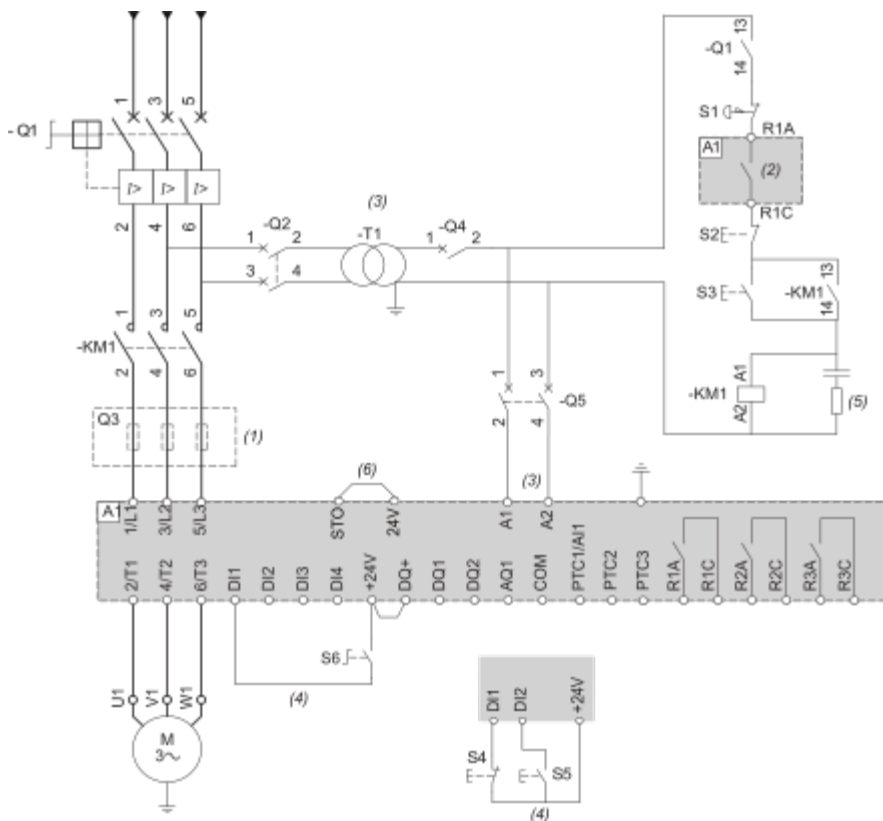

- (1) : Installation of additional fast-acting fuses is mandatory to upgrade to type 2 coordination according to IEC 60947-4-2.
- (2) : Take into account the electrical characteristics of the relays.
- (3) : The transformer must supply 110...230 Vac +10% - 15%, 50/60Hz.
- (4) : 3-wire control and 2-wire control.
- (5) : Select the appropriate voltage surge suppressor.
- (6) : STO Safe Torque Off

Designation	Component	Description
Q1	Circuit breaker	Short circuit protection device for the motor
Q2	Circuit breaker	Short circuit protection device for the primary of the transformer
Q3	Fast acting fuses	Short circuit protection device of the soft starter to be used only when type 2 coordination
Q4	Circuit breaker	Short circuit protection device for the secondary of the transformer
Q5	Circuit breaker	Short circuit protection device for the control part of the soft starter
KM1	Contacteur	Line contactor
S1	Emergency Stop push-button	Emergency Stop to de-energized KM1 line contactor
S2	Normally close push-button	Power OFF
S3	Normally open push-button	Power ON
S4	Normally close contact push-button	STOP command for 3-wire control

S5	Normally open contact push-button	RUN command for 3-wire control
S6	Selector switch, 2 positions, stay-put, normally open contact	RUN/STOP command for 2-wire control

Connection In Line, With Line Contactor, Type 1 or 2 Coordination, 2-wire control

Line contactor controlled based on RUN & STOP or on detected error.

Use relay output R1 set to [Mains Contactor]

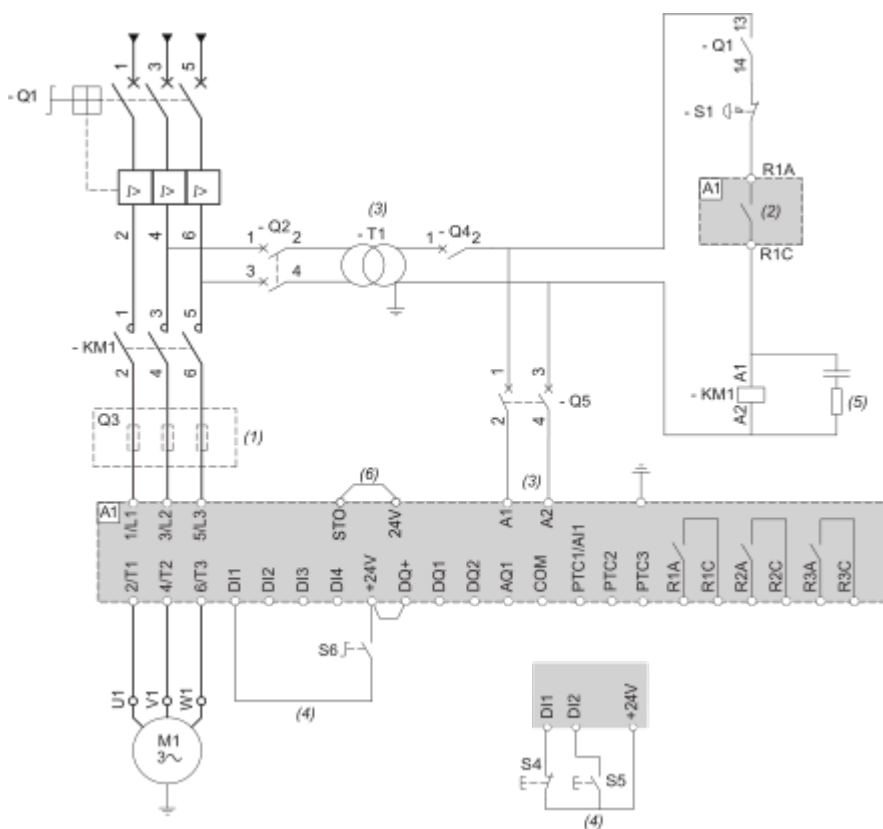

- (1) : Installation of additional fast-acting fuses is mandatory to upgrade to type 2 coordination according to IEC 60947-4-2.
- (2) : Take into account the electrical characteristics of the relays.
- (3) : The transformer must supply 110...230 Vac +10% - 15%, 50/60Hz.
- (4) : 2-wire control and 3-wire control.
- (5) : Select the appropriate voltage surge suppressor.
- (6) : STO Safe Torque Off.

Designation	Component	Description
Q1	Circuit breaker	Short circuit protection device for the motor
Q2	Circuit breaker	Short circuit protection device for the primary of the transformer
Q3	Fast acting fuses	Short circuit protection device of the soft starter to be used only when type 2 coordination according to IEC 60947-4-2 is required
Q4	Circuit breaker	Short circuit protection device for the secondary of the transformer

Q5	Circuit breaker	Short circuit protection device for the control part of the soft starter
KM1	Contacteur	Line contactor
S1	Emergency Stop push-button	Emergency Stop to de-energized KM1 line contactor
S4	Normally close contact push-button	STOP command for 3-wire control
S5	Normally open contact push-button	RUN command for 3-wire control
S6	Selector switch, 2 positions, stay-put, normally open contact	RUN/STOP. command for 2-wire control

Connection Inside the Delta, Type 1 and 2 Coordination, 2-wire or 3-wire

Line contactor controlled based on RUN and STOP command or detected error

Use relay output R1 set to [Operating State Fault] (factory setting).

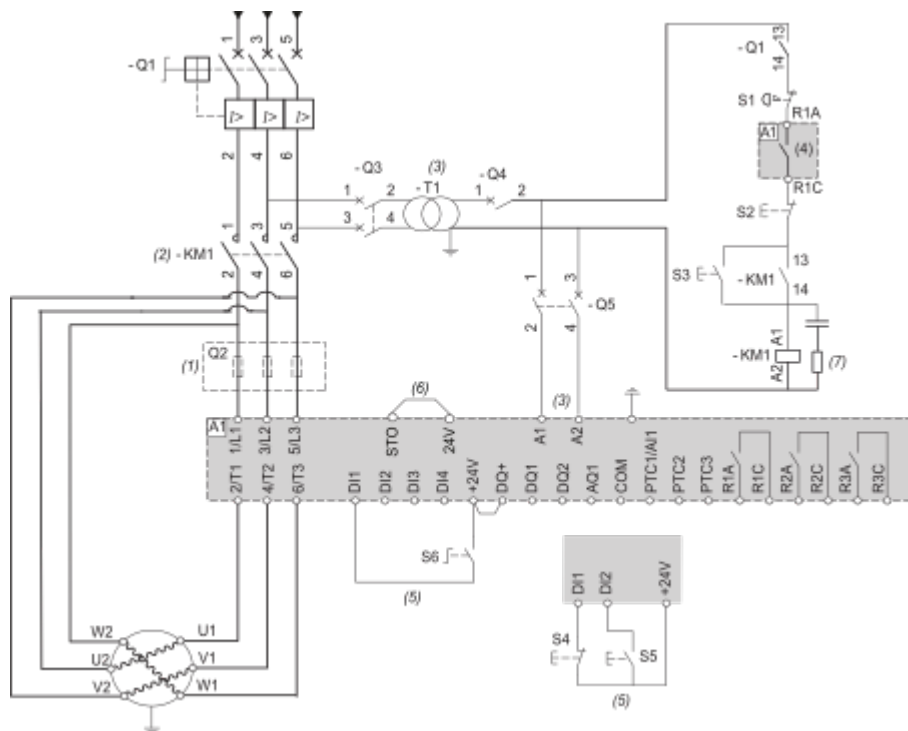

- (1) : Installation of additional fast-acting fuses is mandatory to upgrade to type 2 coordination according to IEC 60947-4-2.
- (2) : KM1 is mandatory to avoid uncontrolled voltage on the motor.
- (3) : The transformer must supply 110...230 Vac +10% — 15%, 50/60Hz.
- (4) : Take into account the electrical characteristics of the relays, especially when connecting to high rating contactor.
- (5) : 3-wire control, 2-wire control.
- (6) : STO Safe Torque Off.
- (7) : Select the appropriate voltage surge suppressor.

Designation	Component	Description
Q1	Circuit breaker	Short circuit protection device for the motor

Q2	Fast acting fuses	Short circuit protection device of the soft starter to be used only when type 2 coordination according to IEC 60947-4-2 is required
Q3	Circuit breaker	Short circuit protection device for the primary of the transformer
Q4	Circuit breaker	Short circuit protection device for the secondary of the transformer
Q5	Circuit breaker	Short circuit protection device for the control part of the soft starter
KM1	Contactora	Line contactora
S1	Emergency Stop push-button	Emergency Stop to de-energized KM1 line contactora
S2	Normally close push-button	Power OFF
S3	Normally open push-button	Power ON
S4	Normally close contact push-button	STOP command for 3-wire control
S5	Normally open contact push-button	RUN command for 3-wire control
S6	Selector switch, 2 positions, stay-put, normally open contact	RUN/STOP. command for 2-wire control

Connection Inside the Delta, Type 1 or 2 Coordination, 2-wire or 3-wire

Line contactora controlled based on RUN and STOP command or detected error

Use relay output R1 set to [Mains Contactora]

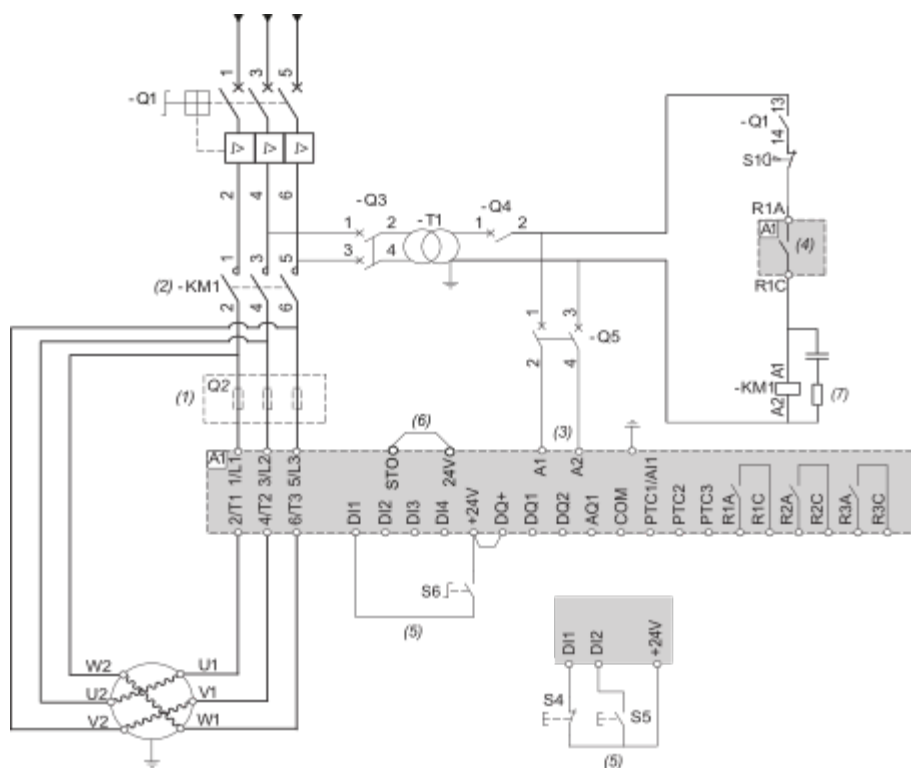

- (1) : Installation of additional fast-acting fuses is mandatory to upgrade to type 2 coordination according to IEC 60947-4-2.
- (2) : KM1 is mandatory to avoid uncontrolled voltage on the motor.
- (3) : The transformer must supply 110...230 Vac +10% — 15%, 50/60Hz.
- (4) : Take into account the electrical characteristics of the relays.
- (5) : 3-wire control and 2-wire control.
- (6) : STO Safe Torque Off.
- (7) : Select the appropriate voltage surge suppressor.

Designation	Component	Description
Q1	Circuit breaker	Short circuit protection device for the motor
Q2	Circuit breaker	Short circuit protection device for the primary of the transformer
Q3	Fast acting fuses	Short circuit protection device of the soft starter to be used only when type 2 coordination
Q4	Circuit breaker	Short circuit protection device for the secondary of the transformer
Q5	Circuit breaker	Short circuit protection device for the control part of the soft starter
KM1	Contacteur	Line contactor
S1	Emergency Stop push-button	Emergency Stop to de-energized KM1 line contactor
S4	Normally close contact push-button	STOP command for 3-wire control and power Off
S5	Normally open contact push-button	RUN command for 3-wire control and power On
S6	Selector switch, 2 positions, stay-put, normally open contact	RUN/STOP command for 2-wire control

Control Block Wiring Diagram

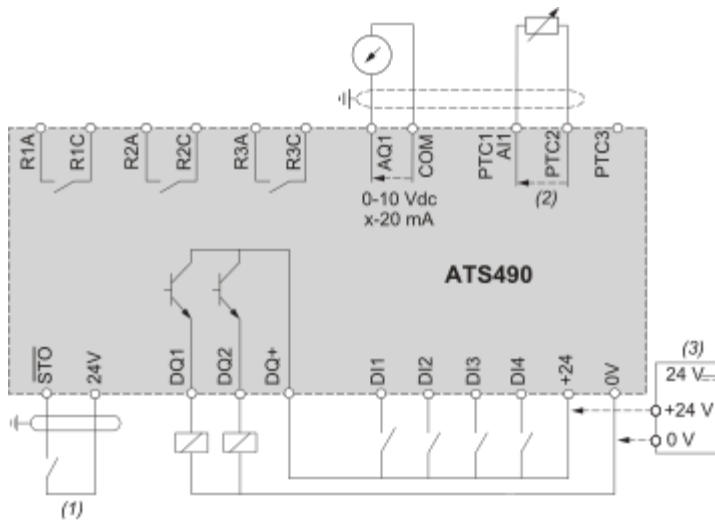

- R1A, R1C, R2A, R2C, R3A, R3C : Programmable NO relays
- DI1, DI2, DI3, DI4 : Digital inputs
- AQ1 : Analogue output
- PTC1/AI1, PTC2, PTC3 : Motor thermal sensor connection
- DQ1, DQ2, DQ+ : Digital outputs
- STO : Safety function STO input
- (1) : STO Safe Torque Off
- (2) : 2 wire PTC/PT100/PT1000/KTY
- (3) : Optional, in case of +24 External Supply usage
- PT100, PT1000 Thermal Probe 3 Wires :

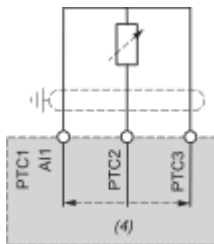

(4) : 3 wire PT100/PT1000

Technical Illustration

Dimensions

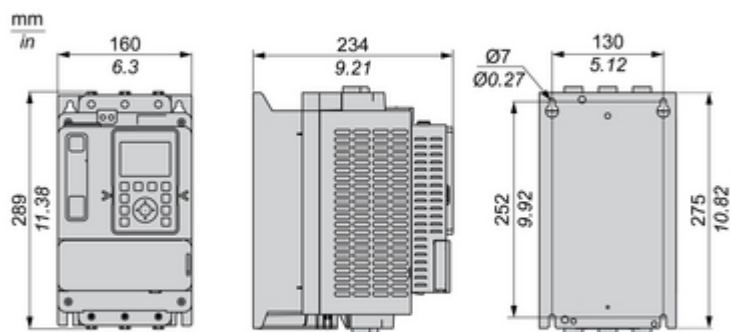

Technical Illustration

Wiring diagram

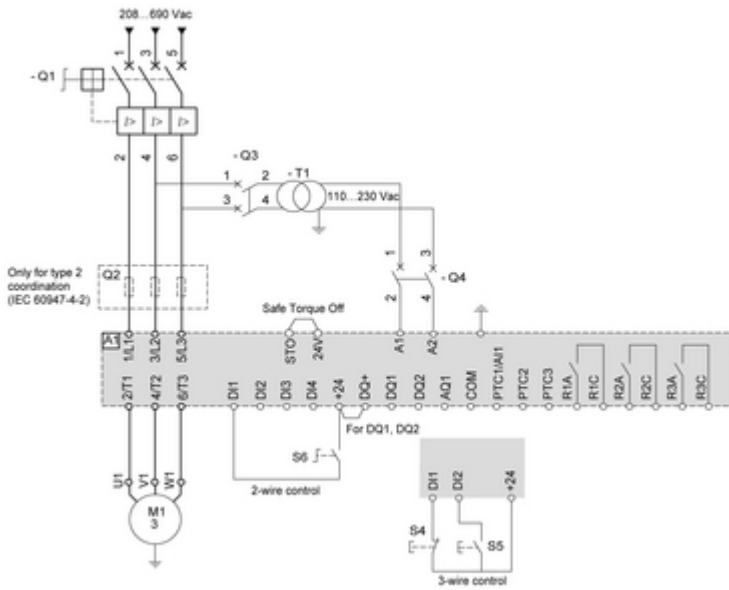

Image of product / Alternate images

Alternative





