

PowerXL™

DE1 Variable Speed Starter I/O Configuration



Level 2	<p>1 – Fundamental – No previous experience necessary</p> <p>2 – Basic – Basic knowledge recommended</p> <p>3 – Advanced – Reasonable knowledge required</p> <p>4 – Expert – Good experience recommended</p>
---------	--

Contents

1	General	5
2	Hardware.....	6
2.1	Designation of the control terminals and technical data.....	6
2.2	Wiring examples	6
2.2.1	Example 1: Application motor starter	6
2.2.2	Example 2: Application with variable speed.....	7
2.2.3	Example 3: Control voltage from an external voltage source.....	7
2.2.4	Example 4: external reference value	8
2.2.5	Example 5: control by a PLC.....	8
2.3	Relay output.....	9
3	Configuration	10
3.1	Inputs.....	10
3.1.1	Terminal configuration.....	10
3.1.2	Displaying input signals	15
3.1.3	Configuration of digital input DI3.....	16
3.1.4	Configuration of analog input AI1	16
3.2	Relay output.....	17
3.2.1	Selecting the function of RO1 (DE11 only)	18

Danger! - Dangerous electrical voltage!

- Disconnect the power supply of the device.
- Ensure that devices cannot be accidentally restarted.
- Verify isolation from the supply.
- Cover or enclose any adjacent live components.
- Follow the engineering instructions (AWA/IL) for the device concerned.
- Only suitably qualified personnel in accordance with EN 50110-1/-2 (VDE 0105 Part 100) may work on this device/system.
- Before installation and before touching the device ensure that you are free of electrostatic charge.
- The functional earth (FE, PES) must be connected to the protective earth (PE) or the potential equalization. The system installer is responsible for implementing this connection.
- Connecting cables and signal lines should be installed so that inductive or capacitive interference does not impair the automatic control functions.
- Suitable safety hardware and software measures should be implemented for the I/O interface so that an open circuit on the signal side does not result in undefined states.
- Deviations of the mains voltage from the rated value must not exceed the tolerance limits given in the specification, otherwise this may cause malfunction and/or dangerous operation.
- Emergency stop devices complying with IEC/EN 60204-1 must be effective in all operating modes. Unlatching of the emergency-stop devices must not cause a restart.
- Devices that are designed for mounting in housings or control cabinets must only be operated and controlled after they have been properly installed and with the housing closed.
- Wherever faults may cause injury or material damage, external measures must be implemented to ensure a safe operating state in the event of a fault or malfunction (e.g. by means of separate limit switches, mechanical interlocks etc.).
- Variable speed starters may have hot surfaces during and immediately after operation.
- Removal of the required covers, improper installation or incorrect operation of motor or variable speed starter may destroy the device and may lead to serious injury or damage.
- The applicable national safety regulations and accident prevention recommendations must be applied to all work carried on live variable speed starters.
- The electrical installation must be carried out in accordance with the relevant electrical regulations (e.g. with regard to cable cross sections, fuses, PE).
- Transport, installation, commissioning and maintenance work must be carried out only by qualified personnel (IEC 60364, HD 384 and national occupational safety regulations).
- Installations containing variable speed starters must be provided with additional monitoring and protective devices in accordance with the applicable safety regulations. Modifications to the variable speed starters using the operating software are permitted.
- All covers and doors must be kept closed during operation.
- To reduce the hazards for people or equipment, the user must include in the machine design measures that restrict the consequences of a malfunction or failure of the variable speed starter (increased motor speed or sudden standstill of motor). These measures include:
 - Other independent devices for monitoring safety related variables (speed, travel, end positions etc.).
 - Electrical or non-electrical system-wide measures (electrical or mechanical interlocks).
 - Never touch live parts or cable connections of the variable speed starter after it has been disconnected from the power supply. Due to the charge in the capacitors, these parts may still be alive after disconnection. Consider appropriate warning signs.

Disclaimer

The information, recommendations, descriptions, and safety notations in this document are based on Eaton's experience and judgment and may not cover all contingencies. If further information is required, an Eaton sales office should be consulted. Sale of the product shown in this literature is subject to the terms and conditions outlined in the applicable Terms and Conditions for Sale of Eaton or other contractual agreement between Eaton and the purchaser. THERE ARE NO UNDERSTANDINGS, AGREEMENTS, WARRANTIES, EXPRESSED OR IMPLIED, INCLUDING WARRANTIES OF FITNESS FOR A PARTICULAR PURPOSE OR MERCHANTABILITY, OTHER THAN THOSE SPECIFICALLY SET OUT IN ANY EXISTING CONTRACT BETWEEN THE PARTIES. ANY SUCH CONTRACT STATES THE ENTIRE OBLIGATION OF EATON. THE CONTENTS OF THIS DOCUMENT SHALL NOT BECOME PART OF OR MODIFY ANY CONTRACT BETWEEN THE PARTIES. As far as applicable mandatory law allows so, in no event will Eaton be responsible to the purchaser or user in contract, in tort (including negligence), strict liability, or otherwise for any special, indirect, incidental, or consequential damage or loss whatsoever, including but not limited to damage or loss of use of equipment, plant or power system, cost of capital, loss of power, additional expenses in the use of existing power facilities, or claims against the purchaser or user by its customers resulting from the use of the information, recommendations, and descriptions contained herein. The information contained in this manual is subject to change without notice.

1 General

The variable speed starters of the series **PowerXL™ DE1** are configured for many applications by default. In addition there is the possibility to adopt the devices to the application. Not only internal variables like ramp times or speed are changed, but also different functions can be assigned to the terminals. This possibility is universal inside the DE1 series and does not depend on the power rating.

This Application Note describes

- the existing input and output terminals
- the technical data
- the assignment of functions to terminals
- the configuration of the I/Os

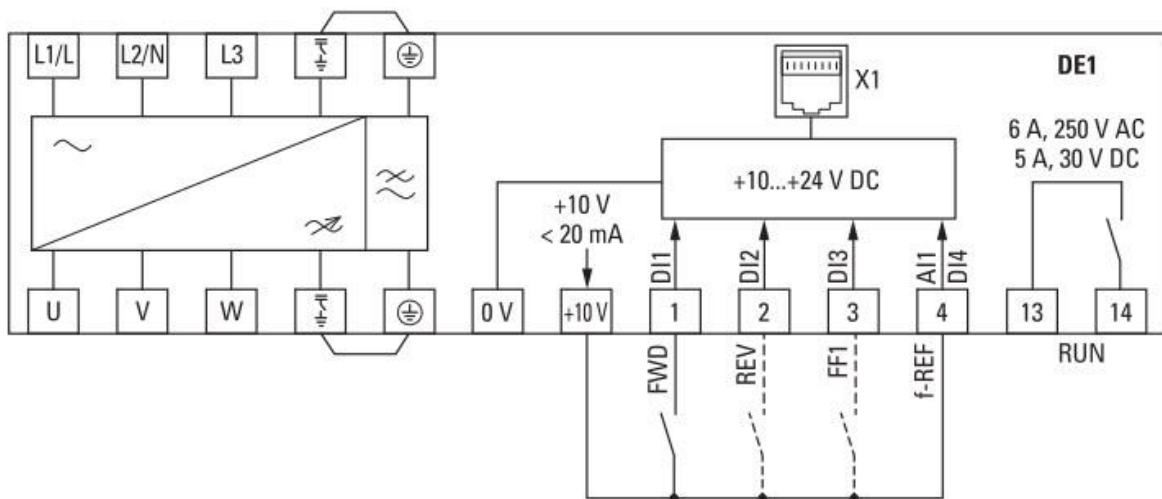

Wiring diagram of a variable speed starter DE1 with default settings

2 Hardware

All signals at the input terminal have the same signal common (0 V). Terminal 4 can be used as digital input as well as analog input. The respective function depends on the configuration (see chapter 3ff).

2.1 Designation of the control terminals and technical data

Designation	Function		Default
0 V	Signal common for all inputs (terminals. 1 ... 4)		-
+ 10 V	Control voltage and reference voltage	20 mA max. Signal common: 0 V	-
1 (DI1)	Digital input 1	HIGH: 9 ... 30 V 10 V: 1,15 mA / 24 V: 3 mA	FWD
2 (DI2)	Digital input 2	HIGH: 9 ... 30 V 10 V: 1,15 mA / 24 V: 3 mA	REV
3 (DI3)	Digital input 3	HIGH: 9 ... 30 V 10 V: 0,12 mA / 24 V: 0,3 mA	FF1
4 (AI1 / DI4)	Analog input 1 or digital input 4	analog: 0 ... 10 V; 0,12 mA 0/4 ... 20 mA, $R_B = 500 \Omega$ digital: HIGH: 9 ... 30 V 10 V: 0,12 mA / 24 V: 0,3 mA	REF (analog, 0 ... 10 V)
13	Relay RO1 (NO)	250 V, 6 A AC / 30 V, 5 A DC	RUN, device enabled
14			

2.2 Wiring examples

The control terminals of the devices DE1 are fixed. On the variant DE11, the terminal block for the control signals is pluggable. To apply control signals to the terminals, the internal 10 V as well as external voltages, e.g. 24 V from a PLC, can be used.

2.2.1 Example 1: Application motor starter

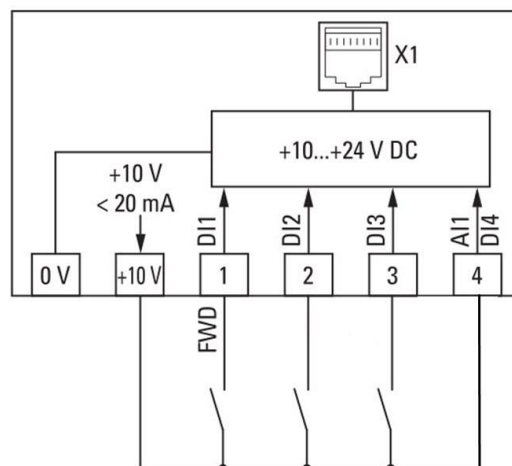

2.2.2 Example 2: Application with variable speed

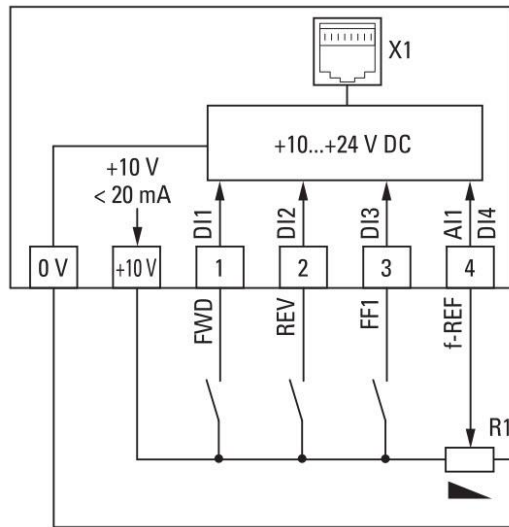

2.2.3 Example 3: Control voltage from an external voltage source

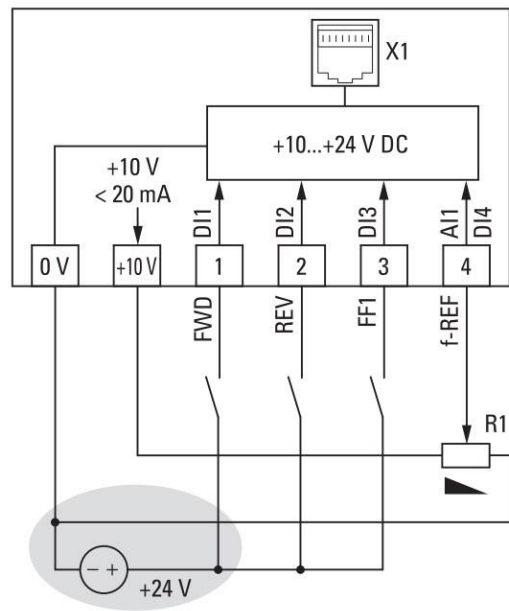

2.2.4 Example 4: external reference value

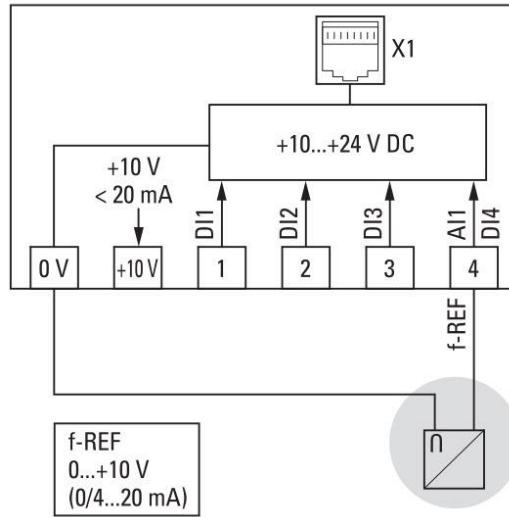

2.2.5 Example 5: control by a PLC

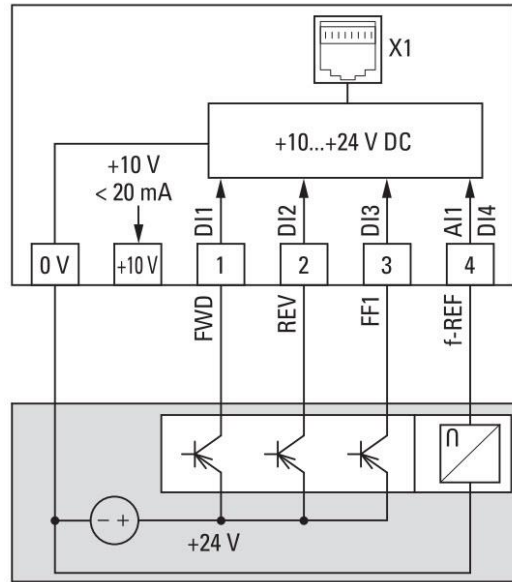

2.3 Relay output

Depending on the kind of load, we recommend the use of protection circuitry for the relay outputs.

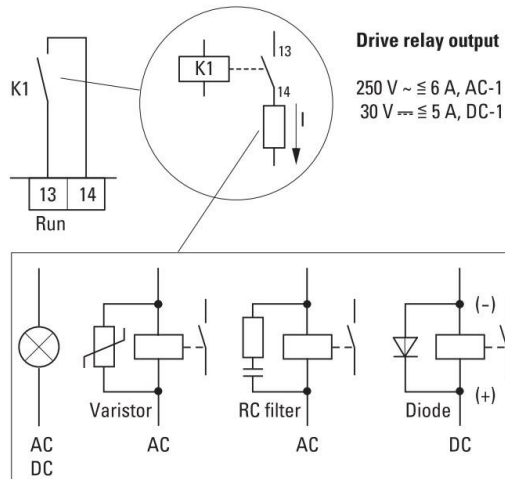

3 Configuration

The table gives an overview, how to determine the function of the single I/Os.

Designation	Selection / setting of					
	Function	Format (signal range)	Scaling (Gain)	Inversion	Hysteresis	Offset
0 V	fixed	-	-	-	-	-
+10 V	fixed	-	-	-	-	-
1 (DI1)	P-12 / P-15	-	-	-	-	-
2 (DI2)		-	-	-	-	-
3 (DI3)		-	-	P-19	-	-
4 (AI1 / DI4)		P-16	P-17	P-18	-	P-44
DE1: 13	fixed	-	-	-	-	-
DE1: 14		-	-	-	-	-
DE11: 13	P-51	-	-	-	P-52 / P-53	-
DE11: 14		-	-	-	/ P-54	-

3.1 Inputs

The function of the inputs can be configured in different ways:

- using the default settings.
- configuration with the configuration module DXE-EXT-SET. The numbers at the selector switch correspond to the settings of P-15 in terminal mode (P-12 = 0)
- via the optional keypad DX-KEY-LED
- via the parameter software DrivesConnect

The available terminal combinations depend on the selection of the “Local ProcessData Source” (P-12). Default: P-15 = 0, P-12 = 0.

3.1.1 Terminal configuration

PNU	Parameter	Name	Range	Default
423.0	P-15	DI Config Select	0 ... 9	0

P-12 = 0: Terminal Mode				
P-15	DI1 (terminal 1)	DI2 (terminal 2)	DI3 (terminal 3)	AI1 / DI4 (terminal 4)
0	FWD	REV	FF1	REF
1	FWD	REV	EXTFLT	REF
2	FWD	REV	FF2 ⁰	FF2 ¹
3	FWD	FF1	EXTFLT	REF
4	FWD	UP	FF1	DOWN
5	FWD	UP	EXTFLT	DOWN
6	FWD	REV	UP	DOWN
7	FWD	FF2 ⁰	EXTFLT	FF2 ¹
8	START	DIR	FF1	REF
9	START	DIR	EXTFLT	REF

P-12 = 1: Keypad Mode (Unipolar)				
P-15	DI1 (terminal 1)	DI2 (terminal 2)	DI3 (terminal 3)	AI1 / DI4 (terminal 4)
0	FWD	REV	FF1	no function
1	FWD	REV	EXTFLT	no function
2	FWD	REV	FF2 ⁰	FF2 ¹
3	FWD	FF1	EXTFLT	no function
4	FWD	UP	FF1	DOWN
5	FWD	UP	EXTFLT	DOWN
6	FWD	REV	UP	DOWN
7	FWD	FF2 ⁰	EXTFLT	FF2 ¹
8	START	DIR	FF1	no function
9	START	DIR	EXTFLT	no function

P-12 = 2: Keypad Mode (Bipolar)				
P-15	DI1 (terminal 1)	DI2 (terminal 2)	DI3 (terminal 3)	AI1 / DI4 (terminal 4)
0	FWD	REV	FF1	no function
1	FWD	REV	EXTFLT	no function
2	FWD	REV	FF2 ⁰	FF2 ¹
3	FWD	FF1	EXTFLT	no function
4	FWD	UP	FF1	DOWN
5	FWD	UP	EXTFLT	DOWN
6	FWD	REV	UP	DOWN
7	FWD	FF2 ⁰	EXTFLT	FF2 ¹
8	START	INV	FF1	no function
9	START	INV	EXTFLT	no function

P-12 = 3: Modbus				
P-15	DI1 (terminal 1)	DI2 (terminal 2)	DI3 (terminal 3)	AI1 / DI4 (terminal 4)
0	ENA	ENAINV	FF1	no function
1	ENA	ENAINV	EXTFLT	no function
2	ENA	ENAINV	FF2 ⁰	FF2 ¹
3	ENA	FF1	EXTFLT	no function
4	ENA	UP	FF1	DOWN
5	ENA	UP	EXTFLT	DOWN
6	ENA	ENAINV	UP	DOWN
7	ENA	FF2 ⁰	EXTFLT	FF2 ¹
8	ENA	DIR	FF1	no function
9	ENA	DIR	EXTFLT	no function

P-12 = 4: CANopen (internal ramp times) → DE11 only				
P-15	DI1 (terminal 1)	DI2 (terminal 2)	DI3 (terminal 3)	AI1 / DI4 (terminal 4)
0	ENA	ENAINV	FF1	no function
1	ENA	ENAINV	EXTFLT	no function
2	ENA	ENAINV	FF2 ⁰	FF2 ¹
3	ENA	FF1	EXTFLT	no function
4	ENA	UP	FF1	DOWN
5	ENA	UP	EXTFLT	DOWN
6	ENA	REV	UP	DOWN
7	ENA	FF2 ⁰	EXTFLT	FF2 ¹
8	ENA	DIR	FF1	no function
9	ENA	DIR	EXTFLT	no function

P-12 = 5: CANopen (ramps via CANopen) → DE11 only				
P-15	DI1 (terminal 1)	DI2 (terminal 2)	DI3 (terminal 3)	AI1 / DI4 (terminal 4)
0	ENA	ENAINV	FF1	no function
1	ENA	ENAINV	EXTFLT	no function
2	ENA	ENAINV	FF2 ⁰	FF2 ¹
3	ENA	FF1	EXTFLT	no function
4	ENA	UP	FF1	DOWN
5	ENA	UP	EXTFLT	DOWN
6	ENA	REV	UP	DOWN
7	ENA	FF2 ⁰	EXTFLT	FF2 ¹
8	ENA	DIR	FF1	no function
9	ENA	DIR	EXTFLT	no function

P-12 = 9: SWD control + SWD speed reference				
P-15	DI1 (terminal 1)	DI2 (terminal 2)	DI3 (terminal 3)	AI1 / DI4 (terminal 4)
0	START	no function	no function	no function
1	START	no function	EXTFLT	no function
2	START	no function	no function	no function
3	START	no function	EXTFLT	no function
4	START	no function	no function	no function
5	START	no function	EXTFLT	no function
6	START	no function	no function	no function
7	START	no function	EXTFLT	no function
8	START	no function	no function	no function
9	START	no function	EXTFLT	no function

P-12 = 10: SWD control, local speed reference				
P-15	DI1 (terminal 1)	DI2 (terminal 2)	DI3 (terminal 3)	AI1 / DI4 (terminal 4)
0	START	no function	FF1	REF
1	START	no function	EXTFLT	REF
2	START	max speed	FF2 ⁰	FF2 ¹
3	START	FF1	EXTFLT	REF
4	START	UP	FF1	DOWN
5	START	UP	EXTFLT	DOWN
6	START	no function	UP	DOWN
7	START	FF2 ⁰	EXTFLT	FF2 ¹
8	START	no function	FF1	REF
9	START	no function	EXTFLT	REF

P-12 = 11: terminal control + speed reference SWD				
P-15	DI1 (terminal 1)	DI2 (terminal 2)	DI3 (terminal 3)	AI1 / DI4 (terminal 4)
0	START	no function	no function	no function
1	START	no function	EXTFLT	no function
2	START	no function	no function	no function
3	START	no function	EXTFLT	no function
4	START	no function	no function	no function
5	START	no function	EXTFLT	no function
6	START	no function	no function	no function
7	START	no function	EXTFLT	no function
8	START	no function	no function	no function
9	START	no function	EXTFLT	no function

P-12 = 13: SWD control with SWD speed reference				
P-15	DI1 (terminal 1)	DI2 (terminal 2)	DI3 (terminal 3)	AI1 / DI4 (terminal 4)
0	START	ENAREF	ohne Funktion	ohne Funktion
1	START	ENAREF	EXTFLT	ohne Funktion
2	START	ENAREF	ohne Funktion	ohne Funktion
3	START	ENAREF	EXTFLT	ohne Funktion
4	START	ENAREF	ohne Funktion	ohne Funktion
5	START	ENAREF	EXTFLT	ohne Funktion
6	START	ENAREF	ohne Funktion	ohne Funktion
7	START	ENAREF	EXTFLT	ohne Funktion
8	START	ENAREF	ohne Funktion	ohne Funktion
9	START	ENAREF	EXTFLT	ohne Funktion

For the terminal functions the following abbreviations are used:

Abbreviation	Function															
DIR	Used for the selection of the sense of rotation in connection with the START command. Low = cw (FWD) High = ccw (REV) ATTENTION: in case of a wire break the drive reverses in case REV is selected! Alternative: use configuration with FWD/REV.															
DOWN	“Reduce speed” command, when a digital reference is selected. Used in combination with the command UP. In case UP and DOWN are applied simultaneously. The motor reduces its speed for the duration of the simultaneous signals with the deceleration ramp set with “t-dec” (P-04).															
ENA	Enable variable frequency drive. To start the drive an additional start signal (START, FWD, REV) is necessary. When removing ENA, the motor coasts to stop.															
ENAINV	In case ENAINV is used instead of ENA, the sense of rotation is inverted, compared to the one determined by a keypad or a fieldbus. Example: ENA + FWD = FWD, ENAINV + FWD = REV															
ENAREF	Enable signal for the speed reference. This signal is necessary to operate the variable speed starter in addition to START respectively FWD/REV. At disconnection of ENAREF the variable speed starter ramps to stand still, but the variable speed starter will not be disabled.															
EXTFLT	External fault. Enables the inclusion of an external signal into the fault messages of the variable speed starter. P-19 = 0: During operation a High signal must be applied to the terminal. A Low signal leads to a trip with the message “E-trip”. P-19 = 1: During operation a Low signal must be applied to the terminal. A High signal leads to a trip with the message “E-trip”.															
FF1	Selection between the analog speed reference at analog input AI1 (terminal 4) and the fixed frequency 1 (f-Fix1), set with P-20. Low = analog reference, High = f-Fix1															
FF2 ⁰ / FF2 ¹	Selection of the fixed frequency with digital commands. The fixed frequencies f-Fix1 ... f-Fix4 are defined with P-20 ... P-23. <table border="1" data-bbox="805 1518 1134 1688" style="margin-left: auto; margin-right: auto;"> <thead> <tr> <th></th> <th>FF2⁰</th> <th>FF2¹</th> </tr> </thead> <tbody> <tr> <td>f-Fix1 (P-20)</td> <td>L</td> <td>L</td> </tr> <tr> <td>f-Fix2 (P-21)</td> <td>H</td> <td>L</td> </tr> <tr> <td>f-Fix3 (P-22)</td> <td>L</td> <td>H</td> </tr> <tr> <td>f-Fix4 (P-23)</td> <td>H</td> <td>H</td> </tr> </tbody> </table>		FF2 ⁰	FF2 ¹	f-Fix1 (P-20)	L	L	f-Fix2 (P-21)	H	L	f-Fix3 (P-22)	L	H	f-Fix4 (P-23)	H	H
	FF2 ⁰	FF2 ¹														
f-Fix1 (P-20)	L	L														
f-Fix2 (P-21)	H	L														
f-Fix3 (P-22)	L	H														
f-Fix4 (P-23)	H	H														
FWD	START with a clockwise rotating field (FWD = Forward). When applying a High signal to the respective terminal, the motor accelerates with the predefined ramp. Removing the signal leads to a stop. The stop behavior depends on the setting of P-05 “Stop Mode”. At standstill the variable speed starter is disabled. In applications with two directions, counter clockwise rotation is selected with REV. FWD and REV are logically connected (XOR). Applying both signals at the same time leads to a trip of the variable speed starter.															

Abbreviation	Function
REF	Analog input AI1 (terminal 4) is used as speed reference input. P-16: Format (voltage input / current input ...) P-17: Scaling P-18: Inversion
REV	START with a counter clockwise rotating field (REV = Reverse). When applying a High signal to the respective terminal, the motor accelerates with the predefined ramp. Removing the signal leads to a stop. The stop behavior depends on the setting of P-05 "Stop Mode". At standstill the variable speed starter is disabled. In applications with two directions, clockwise rotation is selected with FWD. FWD and REV are logically connected (XOR). Applying both signals at the same time leads to a trip of the variable speed starter.
START	Starts and stops the motor. When applying a High signal to the respective terminal, the motor accelerates with the predefined ramp. Removing the signal leads to a stop. The stop behavior depends on the setting of P-05 "Stop Mode". At standstill the variable speed starter is disabled. In applications with two directions, the sense of rotation is selected with DIR or INV. In applications with Smartwire DT this signal is necessary in addition to the start command coming via bus.
UP	"Increase speed" command, when a digital reference is selected. Used in combination with the command DOWN. In case UP and DOWN are applied simultaneously. The motor reduces its speed for the duration of the simultaneous signals with the deceleration ramp set with "t-dec" (P-04).

3.1.2 Displaying input signals

The status of the inputs can be displayed by selecting the respective parameters.

PNU	Parameter	Name	Range	Default
560.0	P00-01	Analog input1	0.0 ... 100 % input signal	-
550.0 ... 550.3	P00-04	DI1 Status	0 / 1	-

The value, displayed with P00-01, takes also a potential scaling factor (P-17) into account. Example:
 $P00-01 = \text{Signal at AI1 [\%]} \cdot P-17$

The display on the keypad can be used to see the status of the digital inputs DI1 ... DI4. It starts with DI1 on the left hand side of the display. **0** = Low signal, **1** = High signal at the respective input terminal.

Voltages between 9 and 30 V are identified as High signal. If an input is configured as analog input, its status is displayed in P00-04 with **0** with voltage levels up to 9 V, above this with **1**.

3.1.3 Configuration of digital input DI3

Digital input 3 (Terminal 3) can be used to include an external signal into the fault messages. Parameter P-19 (DI3 Logic) determines, if a HIGH or a LOW signal is necessary at terminal 3 to indicate a proper status.

PNU	Parameter	Name	Range	Default
650.2	P-19	DI3 Logic	0 → HIGH = OK, LOW = fault 1 → LOW = OK, HIGH = fault	0

DI3 can be configured in a way, that a thermistor can be used to protect the connected motor. In this case P-19 must be set to 0.

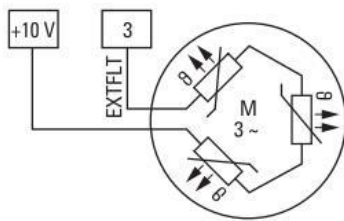

Parameter P-15 has to be set in a way, that the function „External Fault“ (EXTFLT) is assigned to terminal 3 (DI3). During proper operation, a High-Signal is applied to terminal 3. In case of fault the temperature contact must open respectively the resistance of the thermistor has to increase. DE1 trips at a resistance of $\geq 3.6 \text{ k}\Omega$, Reset can be performed at values $\leq 1.6 \text{ k}\Omega$.

ATTENTION: Variable Speed Starters of the series DE1 are designed according IEC / EN 61800-5-1, which requires double isolation between mains circuits and circuits with low voltage. Inside the drive power part and control part are separated accordingly. In case temperature sensors inside the motor are connected to DE1, the sensors have to be double isolated against the motor windings, not to weaken the overall insulation system!

In applications with fire mode (P-45 = 1...4) digital input DI3 is used to apply the fire mode signal to the variable speed starter. Parameter P-19 (DI3 Logic) is not effective in this case. Further information about fire mode is available in application note AP040181EN “DE1 Fire Mode”.

3.1.4 Configuration of analog input AI1

At analog input AI1 (terminal 4) it is also possible to take a scaling factor into account.

- Signal range: Selection of the kind of signal at the analog input. The maximum value of the signal corresponds to the maximum speed / frequency set with P-01.
- Gain: With the gain the analog input can be scaled.
- AI1 Invert:
 - P-18 = 0 → 0 V = minimum frequency, 10 V = maximum frequency
 - P-18 = 1 → 0 V = maximum frequency, 10 V = minimum frequency
- Offset AI1:

With P-44 an offset to the signal at analog input AI1 can be set. It is adjustable in the range between -1.000 and + 1.000. It must be noted, that a negative offset value will be added to the one at AI1, a positive one will be subtracted. Example: P-44 = -0.2 → 20 % of the full scale value are added to the signal coming from AI1. The gain, set with P-17, is also effective for the offset signal.

PNU	Parameter	Name	Range	Default
260.0	P-16	AI1 Signal Range	0: 0 ... 10 V (Y 0–10) 1: 0 ... 20 mA (A 0–20) 2: t 4 ... 20 mA (trip in case of wire break) (τ 4–20) 3: r 4 ... 20 mA (ramps to f-Fix1 (P-20) in case of wire break) (ρ 4–20)	0
261.0	P-17	AI1 Gain	0.100 ... 2.500	1.000
267.0	P-18	AI1 Invert	0 = no inversion 1 = inversion	0
262.0	P-44	AI1 Offset	-1.000 ... +1.000	0

3.2 Relay output

The function of the output relay between the terminals 13 and 14 of the devices DE1 is fixed (RUN).

The contact closes when

- the device is supplied
- no fault message is present
- the start signal is applied (FWD/REV/START)

The contact opens

- at disconnection of the supply voltage
- in case of a fault
- when removing the start signal where the point of opening depends on the selected „Stop Mode“:
 - P-05 = 0 → coasting. The contact opens as soon as the start signal is removed.
 - P-05 = 1 → ramping. The contact opens when the motor is at stand still after a deceleration with the ramp set with „t-dec“ (P-04).

On variants DE11 the function of the relay contact can be configured.

3.2.1 Selecting the function of RO1 (DE11 only)

The function of relay RO1 (terminals 13 and 14) can be selected with parameter P-51.

For the settings P-51 = 4 ... 7, switch on threshold level (P-52) and a hysteresis of the relay (P-53) can be defined.

Switch OFF threshold = „RO1 Upper Limit“ (P-52) – „RO1 Hysteresis“ (P-53)

P-51 = 4 or 5: output will be logic 1 if the value \geq “RO1 Upper Limit” , output will be logic 0 if value < Switch OFF threshold

P-18 = 6 or 7: output will be logic 0 if the value \geq “RO1 Upper Limit” , output will be logic 1 if value < Switch OFF threshold

P-55 defines a switch-on delay, before the relay switches from logic 0 to logic 1.

PNU	Parameter	Name	Range	Default
451.0	P-51	RO1 Function	0: RUN, enable (FWD/REV) 1: READY, DE1 ready for operation 2: Speed = Speed reference value 3: Fault (DE1 not ready) 4: Speed \geq RO1 Upper Limit (P-52) 5: Motor current \geq RO1 Upper Limit (P-52) 6: Speed < RO1 Upper Limit (P-52) 7: Motor current < RO1 Upper Limit (P-52) 8: DE1 not enabled 9: Speed not at speed reference value	0
452.0	P-52	RO1 Upper Limit	0.0 ... 200.0 %	100.0 %
454.0	P-53	RO1 Hysteresis	0.0 ... 100.0 %	0.0 %
457.0	P-54	RO1 Switch-On Delay	0.0 ... 250.0 s	0.0 s