

ENSTALL



FLATFIX FUSION ANCHOR BAR

Montagesysteem voor platte daken

Contents

| | Page |
|---|-------------|
| 1. Introduction | 3 |
| 2. General installation conditions | 3 |
| 3. Product description | 6 |
| 4. Parts overview | 7 |
| 4.1 Exploded view | 7 |
| 4.2 Parts list | 7 |
| 5. Mounting preparation | 8 |
| 5.1 Check of tools and accessories | 8 |
| 5.2 Roof anchor requirements | 9 |
| 5.3 List of accepted anchors | 11 |
| 6. Installation | 14 |
| 6.1 Determining and measuring positions of roof anchors | 14 |
| 6.2 Precision of installation | 14 |
| 6.3 Mounting of anchor bar to base elements | 16 |
| 6.4 Double anchor bar | 18 |
| 6.5 Summary | 19 |

Please ensure you keep this installation guide in a safe location for future reference. If you have questions about the warranty period or terms, we strongly recommend contacting your supplier for further information. Due to our ongoing efforts to improve the quality and features of our products, you may notice slight differences between the product details and the descriptions provided in this manual. Therefore, use the instructions in this guide as a general framework for installing the specified product. Esdec BV disclaims any responsibility for errors in this manual and any consequences that may arise from them. Lastly, all rights are reserved, and unauthorized copying of this manual is strictly prohibited.

1. Introduction

This manual describes the installation of the FlatFix Fusion Anchor Bar for flat roofs (for solar panels in landscape setup).

Read the manual carefully so that you are fully aware of the entire content. Follow the instructions in the manual carefully. Always carry out the actions in the correct order.

To ascertain the accurate positioning of the mounting anchors, adherence to the project plan is imperative at all times.

2. General installation conditions

General

A failure to adhere to the guidelines stated in this document and/or in the construction plan may lead to all warranty and product liability claims lapsing.

The details, comments and recommendations in this document are binding and must be checked to ensure they are complete and up to date. Esdec BV retains the right to revise this document without notification.

Stability and condition of the roof

The roof must be in good condition and strong enough to bear the weight of the solar panels, incl. associated materials, ballast, wind, and snow load. Check the stability of the roof/structure and where necessary employ a builder to correct it. Make sure the load reserve of the roof is not exceeded either locally or in its entirety.

Insulation / roofing material

The continual pressure loading capacity (point load) of the insulation and the roofing material must be checked thoroughly and found to be sound before installation. The suitability of the roof supports combined with the roofing material must be checked and found to be sound, and if necessary or desirable extra roof supports must be fitted at the required locations. In case of doubt, employ a roofer.

Safety warnings

- FlatFix Fusion mounting systems must be fitted as standard by qualified technical personnel (at least two skilled people).
- The addition or omission of parts may have a detrimental effect on the function of the system and is strongly discouraged!
- Before placing the solar panels, the roof must be clean, dry, flat and free of algae and the like.
- Avoid fitting in high winds and a wet, slippery roof surface.
- Fitting of the FlatFix Fusion mounting system may only take place at temperatures between 5° and 40°C (due to the fitments of the plastic parts).
- Always work on a roof using fall protection and safety nets and edge protection where necessary.
- Wear shoes with reinforced toecaps and sturdy anti-slip soles.
- Always wear the proper protective clothing when carrying out the work.
- Always use lifting aids / hoist systems when moving the material (solar panels, etc.).
- Always place a ladder on a sound and stable surface.
- Always place the ladder at an angle of around 75° and ensure it sticks out about 1 meter above the roof edge.
- If possible, fasten the top of the ladder with a rope or strap.

Range of application of FlatFix Fusion Anchor Bar

- Installation temperature range: -15°C - +40°C.
- Wind zone 1 till 3 (besides coastal areas)
- Type of roofing material: Concrete, bitumen / EPDM / PVC / TPO.
- Setup: Landscape mounting. Angle of inclination solar panels: 11,3° till 13°.

Edge zone

The distance of the solar panels to the edge of the roof must be around 1/5 of the height of the building, with a minimum distance of 30 cm (due to the strongly turbulent wind flows in this zone). No solar panels may be fitted to this zone, neither partially nor fully. The edge zone to be observed follows from the Esdec calculator.

Ballast

All ballast is removed when anchor bars are used.

Consult the construction plan for the correct placing of the roof anchors.

Standards, guidelines, and regulations

When fitting a mounting system, it is important that you follow the mounting instructions and associated standards to prevent incidents. Especially, considering the following standards, guidelines, and regulations:

- Dutch Building Code
- PPE Personal Protective Equipment
- KEMA Inspection of Electrical Equipment
- DIN 1055 Design loads for buildings
- DIN 18299 General rules applying to all types of construction work
- DIN 18451 Scaffolding works
- NEN EN 1991
- NEN 7250

Removal and dismantling

Remove the product as per local legislation and regulation. At the end of the design life, all materials are recyclable.

The aluminum base profiles are fastened to the base elements using a click system. Use combination pliers to dismantle the base profile.

Warranty

The warranty is subject to the warranty conditions and the general conditions of Esdec BV. These can be found on our website www.esdec.com.

Liability

The manufacturer does not accept any liability whatsoever for damage or injury caused by a failure to (strictly) comply with the safety guidelines and instructions in this manual, or due to negligence during installation of the product stated in this document and any related accessories.

- printing errors reserved

3. Product Description

The anchor bar is used to attach a FlatFix Fusion system to a roof (see requirements for roof anchor) and ensures safe and reliable installation of your system. You can use Esdec's anchor bar for maximum safety of your flat roof solar project, lowering the amount of ballast or make it suitable for installation under steeper roof angles. The Anchor bar is telescopic and available in 2 sizes covering a wide use range of FlatFix Fusion (1590-2080 mm). FlatFix Fusion Anchor Bar may be used for all types of roofing material.

Placing roof anchors

Roof anchors aren't provided by Esdec. Please consult a third party or a roofer for placing roof anchors on the designated spots on the roof. Consult the construction plan for correct positioning and amount of the needed roof anchors.

4. Parts overview

4.1 Exploded view

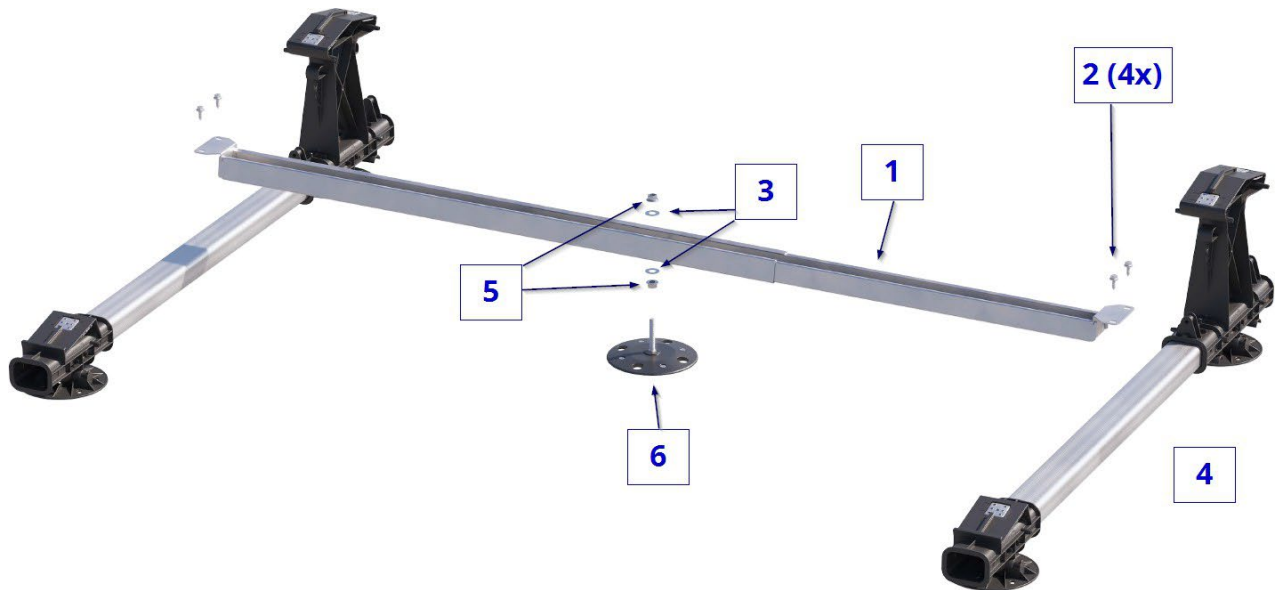

4.2 Parts list

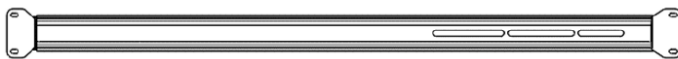

- 1 - FFF Anchor Bar

- 1007270 (L=1590-1800)

- 1007271 (L=1800-2080)



- 2 - Self tapping screw 6,0x25 SW10 HEX/T30

- 1008085



- 3 - PA washer M10

- 1007272

- 4 - Flatfix Fusion System



- 5 - M10 nut

- 6 - Roof anchor

5. Mounting preparation

5.1 Check of tools and accessories

Below a list of necessary tools/aids:

Tape measure

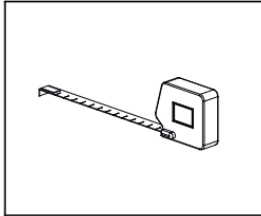

Brush

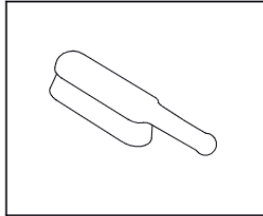

Ratchet with hexagon head

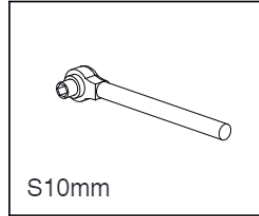

Powered screwdriver

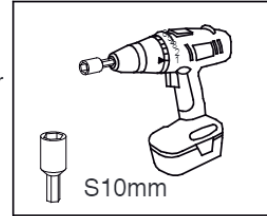

Marker/chalk

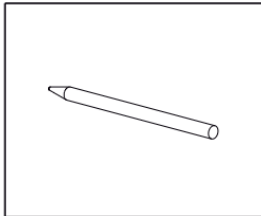

Sealant pistol optional
for roof pitch > 2°/3°

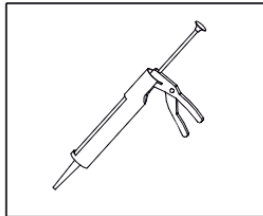

Water pump pliers

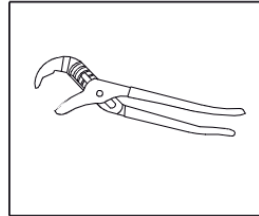

Metal saw

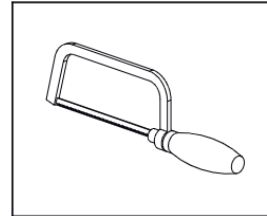

Safety helmet

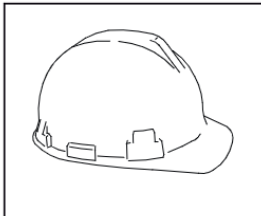

Safety goggles

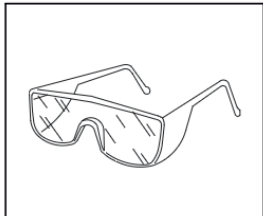

Protective clothing

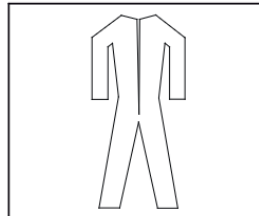

Safety shoes

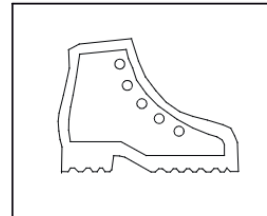

Dust mask

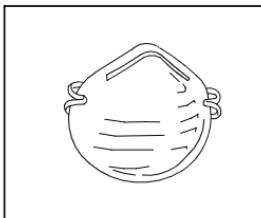

Ear protection



Safety gloves

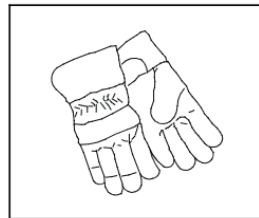

Scaffold or stable safe ladder

5.2 Roof anchor requirements

First check if the project meets the following requirements.

Project requirements:

F_{max} Lift Panel does not exceed 1,667 kN
 F_{max} Sheer Panel does not exceed 0,983 kN
 Panel size is between 1590 and 2080 mm
 Roof pitch is between 0 and max. 13 degrees.

Values are to be determined through our Project Engineering department.
 Only when the project meets these requirements, the anchor bar can be used.

Anchor requirements:

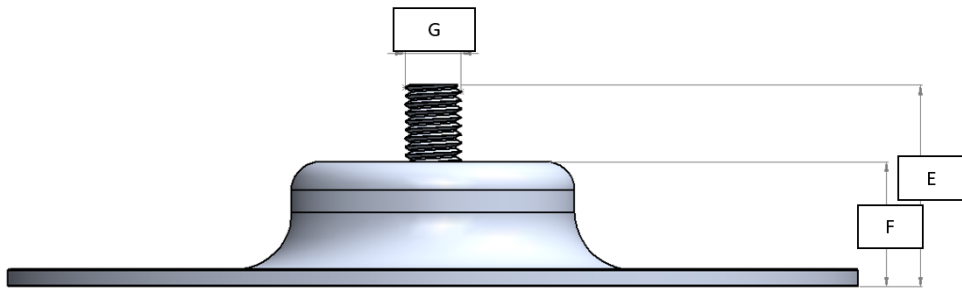

The dimensions of a roof anchor should always be within range defined in the table below.
 The above figure shows the positions of these dimensions.

| Dimension | Requirement |
|-----------|---|
| E | 35,5mm <= Height of anchor thread <= 130mm |
| F | 0 mm <= Height of anchor base* <= 21,5 mm |
| G | Thread dimension: M10 |
| H | F _{max} Lift Anchor > 4,4 kN |
| I | F _{max} Sheer Anchor > 2 kN |
| J | 0 mm <= Precision of anchor placement <= 100 mm |

* When the gap between the anchor base and the bottom of the Anchor Bas is smaller than 10mm, rings should be used to level the interface of the anchor with the interface of the Anchor Bar. When the gap is larger than 10mm, a flange nut with serration can be used underneath the Anchor Bar to level the interface.

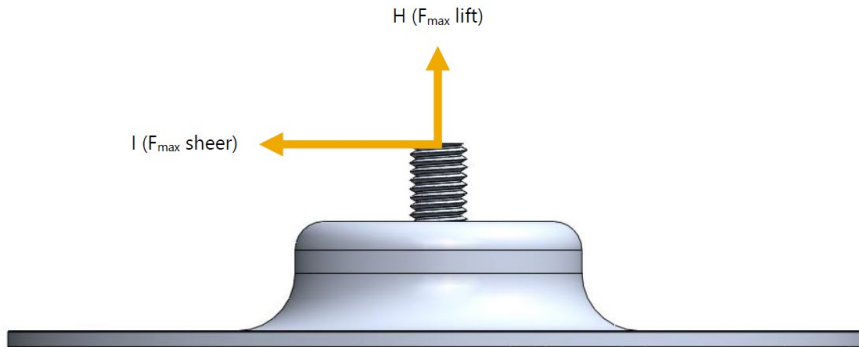

The tip of the anchor bolt should never be above the red line shown in the figure below. When a solar panel sags in case of high pressure (snowload/windload) the back of the sheet of the solar panel could touch the tip of the bolt and cause damage.

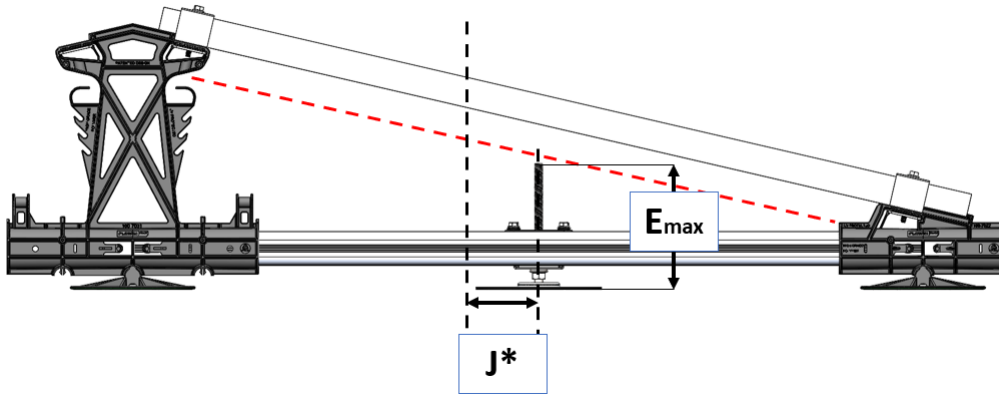

The height of the anchor base should not exceed 21,5 mm. If it does, the anchor will lift the Anchor Bar and the FFF system from the roof and make the system more vulnerable for wind shears resulting in damage to the panels and system.

When dimension G in the figure below is larger than 10mm, a M10 flange nut with serration can be used to level the interface of the anchor with the bottom of the anchor bar.

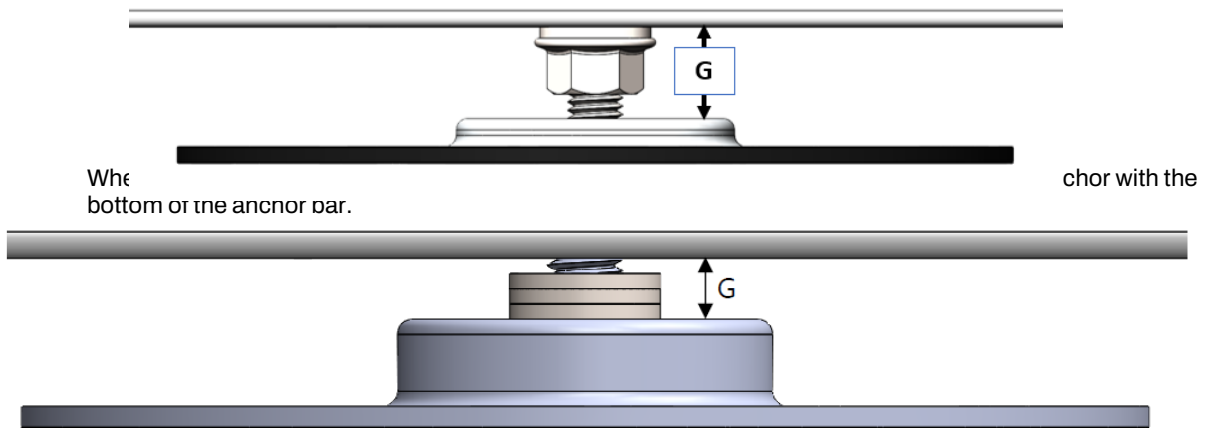

Only M10 threaded anchors can be used with the anchor bar.
A PA M10 washer should always be the interface between the roof anchor and the FFF anchor bar.

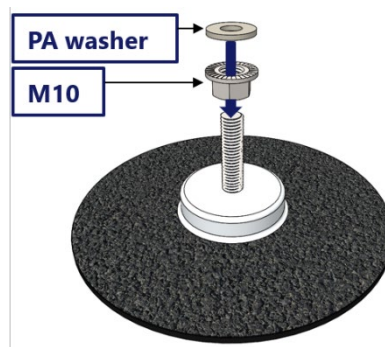

6. Installation

6.1 Determining and measuring position of roof anchors

Measuring and marking out:

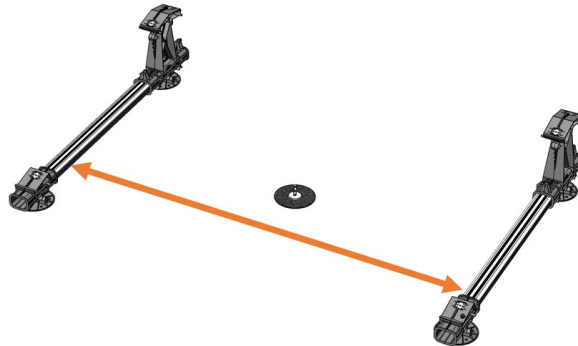

Make sure the system is aligned correctly for the right panel size.
Mark the outlines of the panel field on the roof with chalk or a marker.

6.2 Precision of installation

The roof anchor can be used for anchoring when it is positioned within a radius of [J]mm from the center of the FlatFix Fusion system, as illustrated in the figures below. Esdec can't guarantee that the system will be strong enough to withstand extreme weather conditions when dimension [J] is exceeded. Maximum value for J = 100 mm.

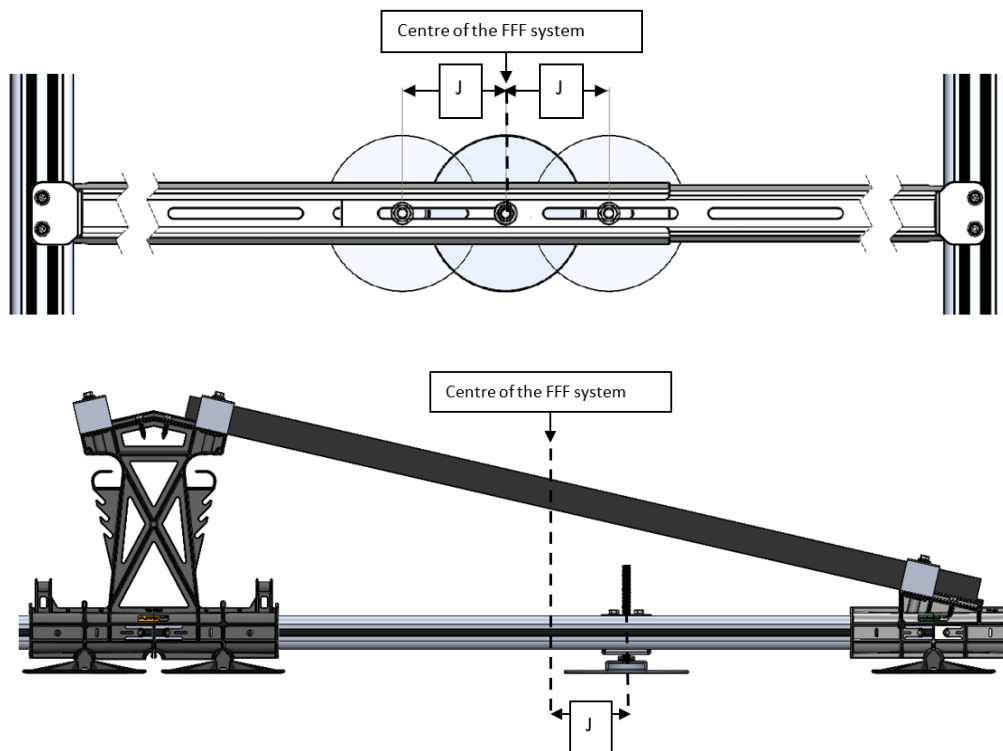

Anchor Bar 1590-1800 Range of accepted panel sizes:

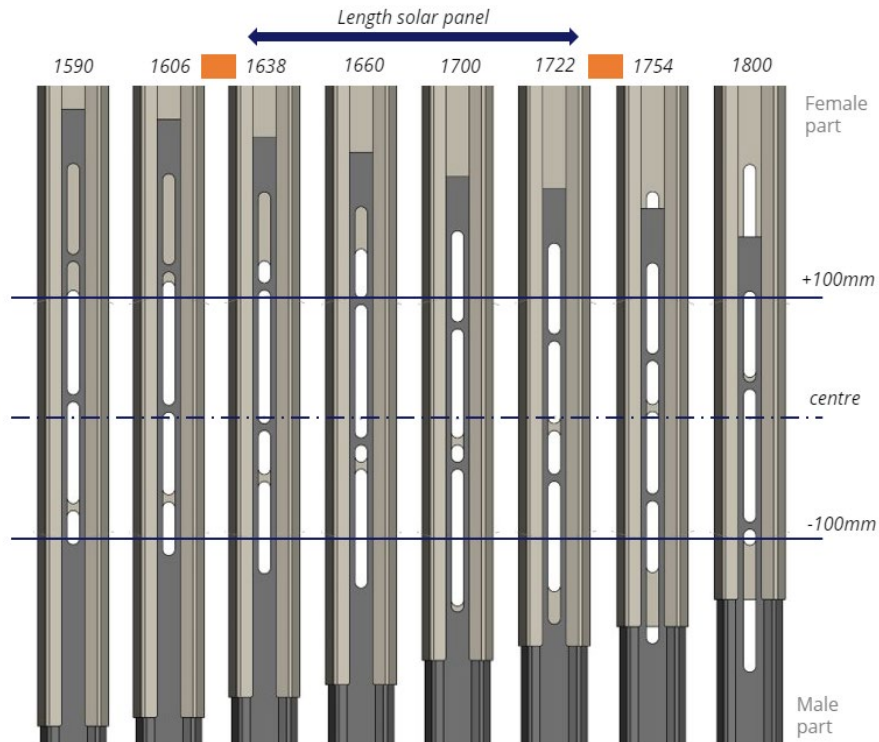

Conflicting panel lengths are: 1606 to 1638 mm and 1722 to 1754 mm.

Anchor Bar 1800-2080 Range of accepted panel sizes:

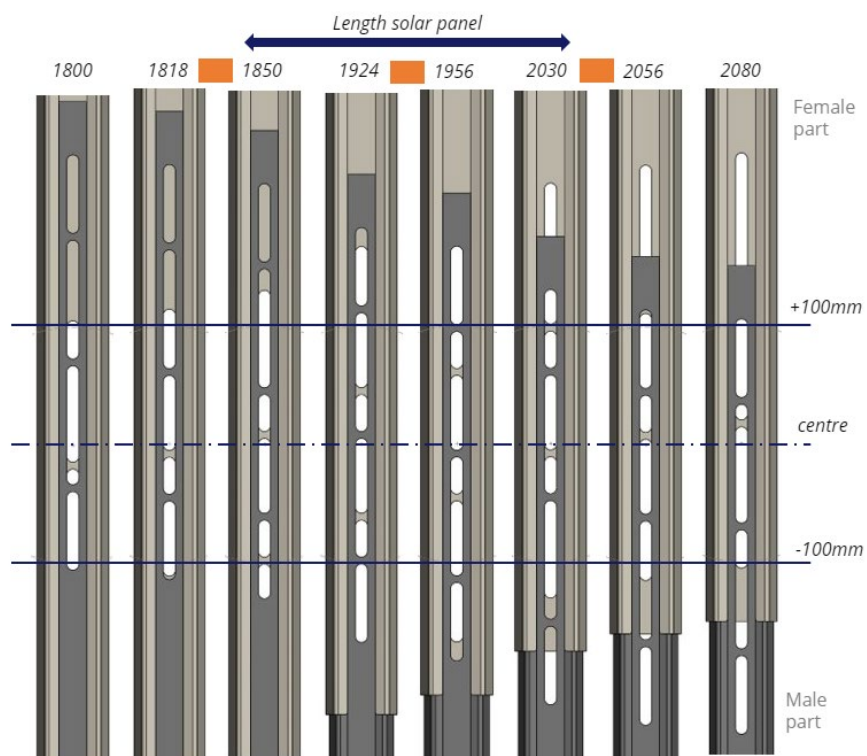

Conflicting panel lengths are: 1818 to 1850 mm and 1924 to 1956 mm.
To solve these conflicting range of panels, placing the anchor bars off center could fix this.

6.3 Mounting anchor bar to base elements

As standard, the high base element is placed on a single roof support.

1. Secure the roof support to the high base element using the click connector. Use the center click connector to the underside of the high base element for this.
Optional: In situations where ballast is to be placed, two roof supports are secured under the high base element. Use the two click connectors at the center (1A) for this.
2. Secure the roof support to the low base element using the click connectors.

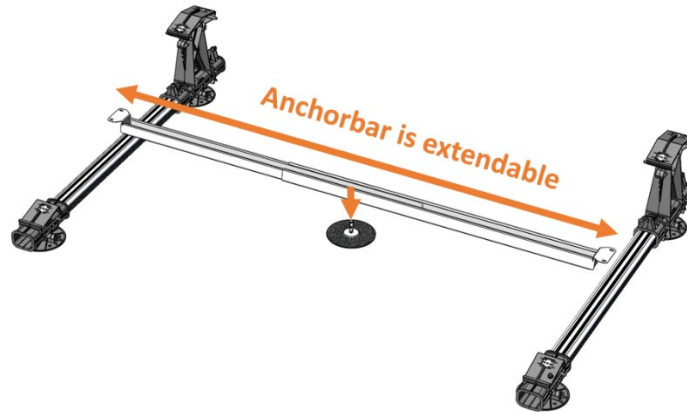

Extend the anchor bar to fit between the two rails.

In case of a conflict, rotate the anchor bar 180 degrees to make it fit properly.

For some panel ranges this step is necessary, see the tables under 6.2 for measurements.

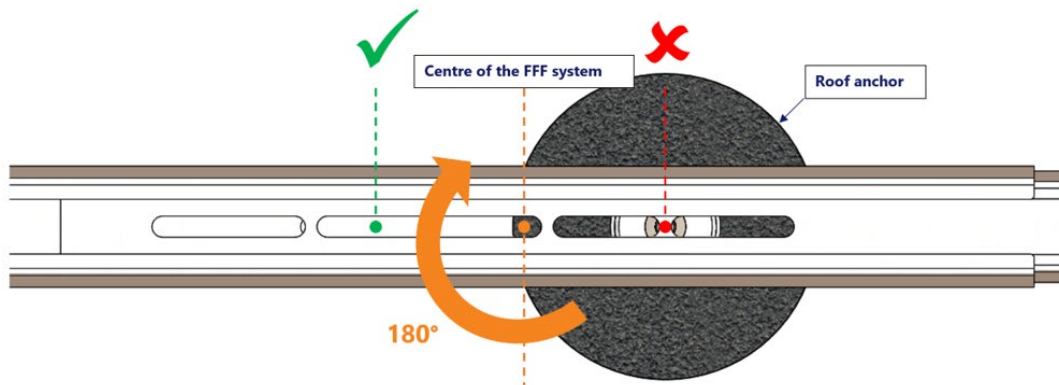

Make sure the front side of the anchor bar is always touching the FlatFix Fusion profile.

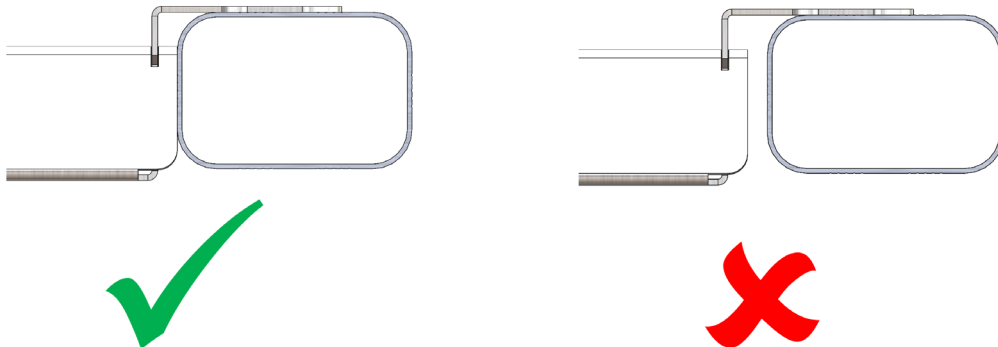

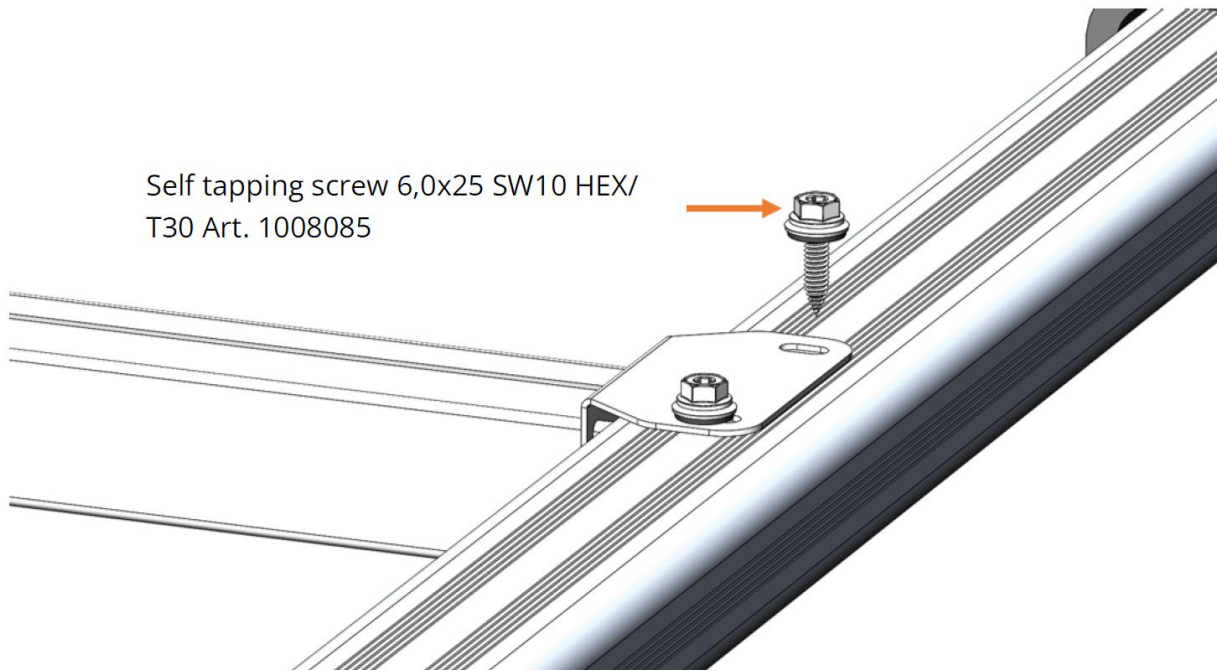

Mount the anchor bar to the FFF profiles.

Fasten the anchor bar to the roof anchor.
Minimum mounting torque is 10 Nm.

A PA M10 washer should always be placed between the anchor bar and the roof anchor.

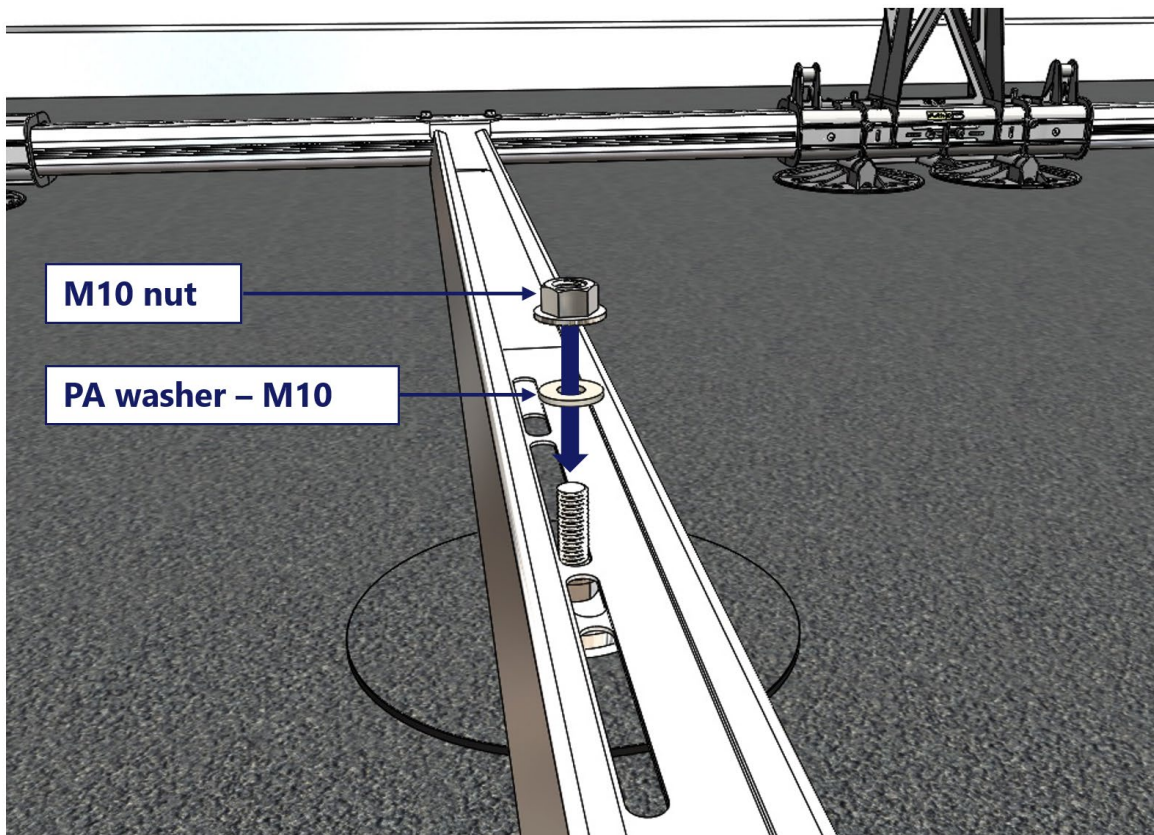

6.4 Anchor Bar alignment

In cases where there are two anchor bars needed under adjacent panels, the anchor bars meet each other in the middle.

Place the anchor of the most outer panel 85 mm towards the perimeter side of the field.

Illustrated below.

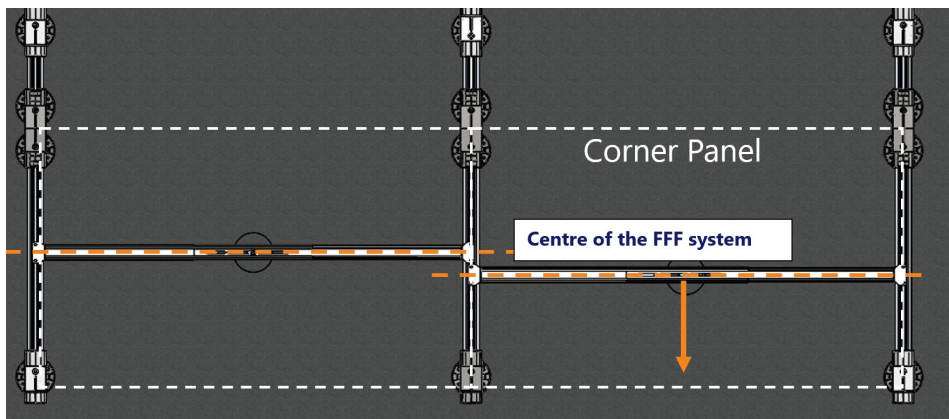
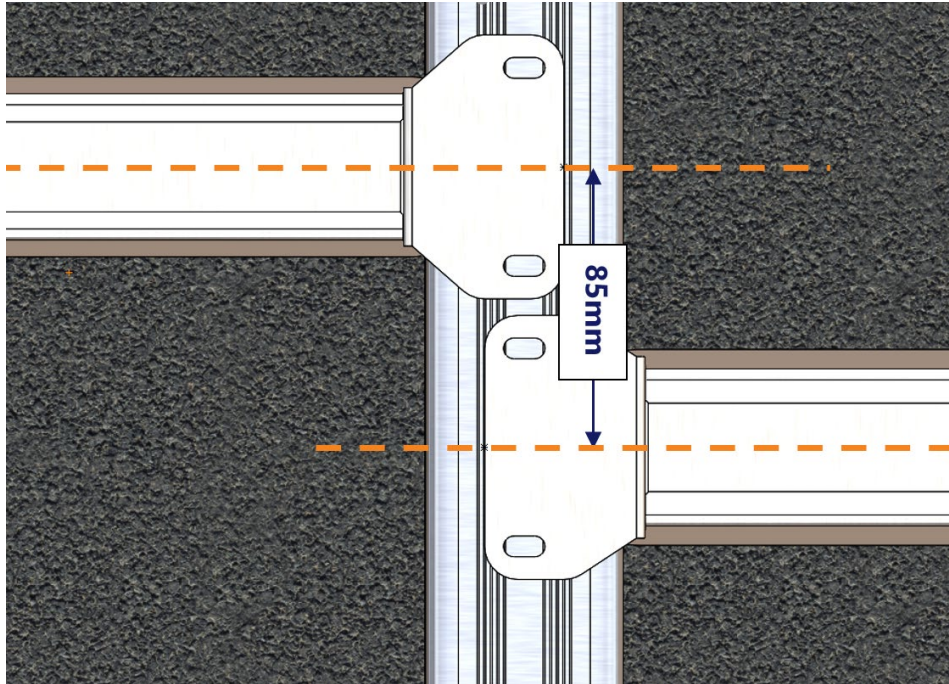

6.5 Summary



1. Measure and mark out the segments on the roof and the exact placement of the roof anchors.

2. Place roof anchors.

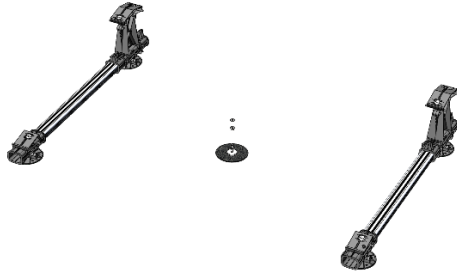

3. Add M10 washer and M10 nut to the roof anchor

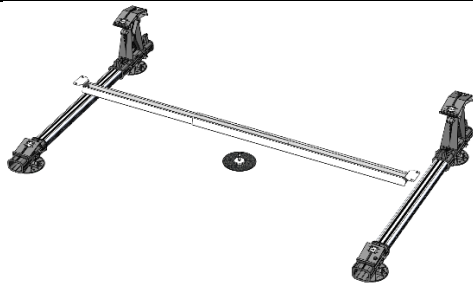

4. Place the extendable anchorbar, make sure the anchorbar is extended in full and touches the FlatFix Fusion frame completely, leaving no gaps.

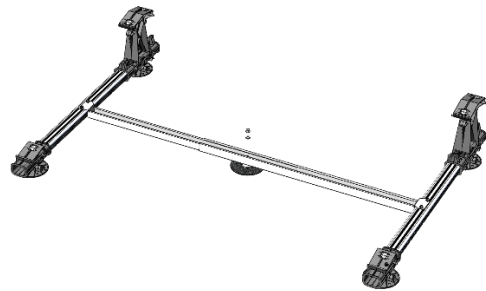

5. Fix the anchorbar with a M10 washer and nut.
Min. torque is 10Nm.

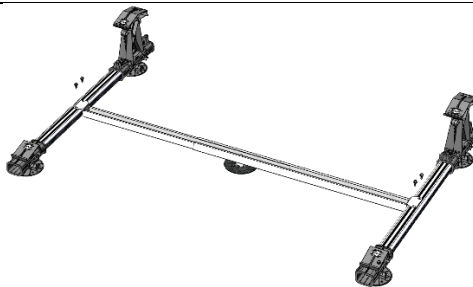

6. Fix the anchorbar to the FlatFix Fusion profiles with 4x self tapping screw 6,0 x 25 SW10 HEX/T30 Art.Nr. 100-8085.



7. Finished. Double check if the anchor bar has washers under and below the anchor bar and there are no gaps between the anchor bar and the Fusion profiles.