

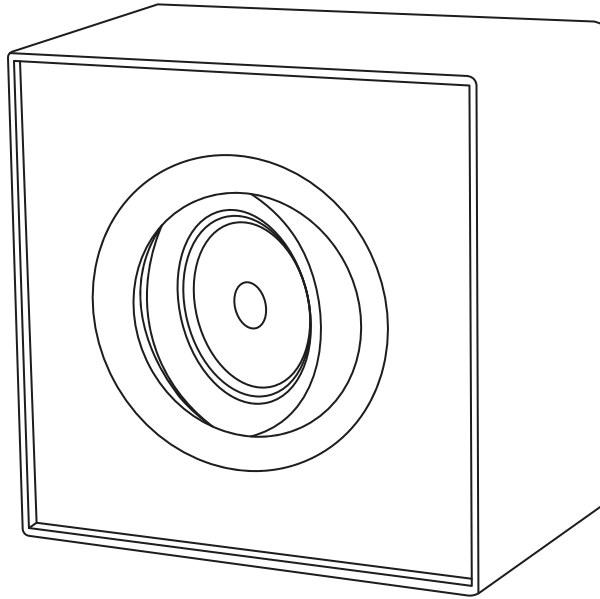

Read these instructions & save for future use

Ceiling light | 8W | 60° | dim to warm 2000~3000K | black



Article number **136-232**

Brand **Tronix Lighting**

Type **Ceiling light**

Contents of this product **1x 8W ceiling light 2000-3000K**

Technical datasheet **Digitally available
on our webshop**



*View instructions and
technical data also on
our website*

TRONIX



Before first use

Before getting started with this product, it is advisable to check the order completeness and any damage. If this is the case, please contact Tronix Lighting.

Description

These surface-mounted spotlights not only feature a modern and timeless design, but also offer a lighting experience that is perfect for a variety of spaces. Consider reception areas, living spaces, hospitality, retail, offices or even outdoors under the canopy.

Features

- Dim to warm from 2000K to 3000K;
- Pre-mounted screw holes for universal recessed boxes;
- Orientable spotlight up to 20°;
- Long lifespan with more than 50,000 burning hours;
- High CRI value >90.

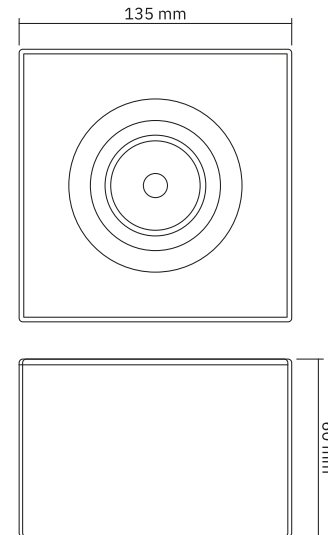

Installation

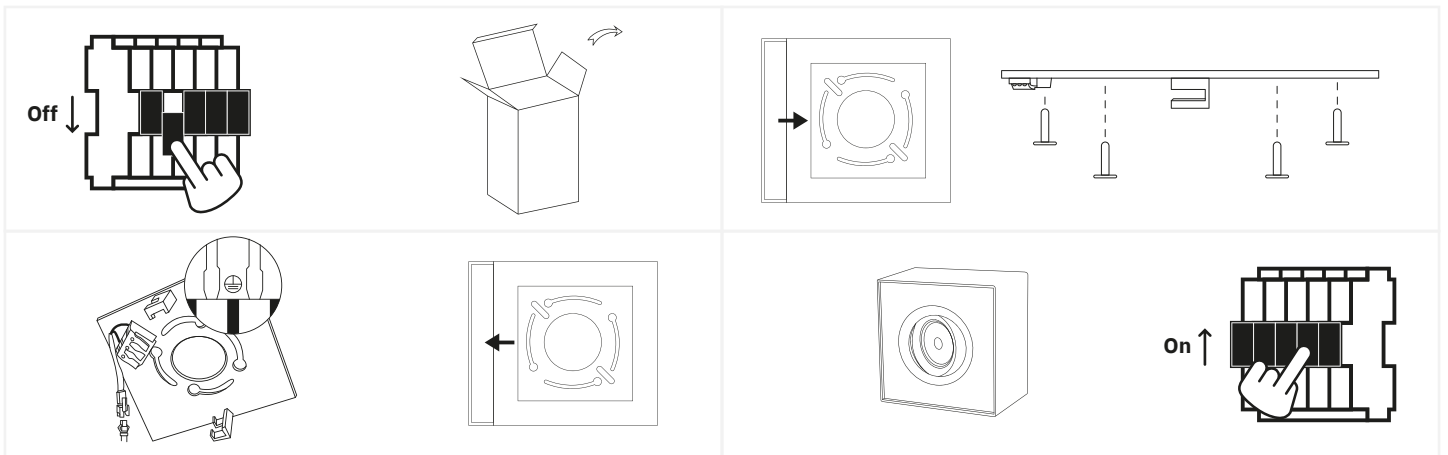

1. Turn off the power and remove the product and associated parts from the packaging.
2. Detach the back of the lamp by sliding it. Then use the screws provided to attach the plate to the ceiling after pulling the power cable;
3. Attach the power to the plate and then connect the lamp to this plate. Plug the lamp back into the back;
4. Check the complete installation. If everything is okay, you can reactivate the power.



Safety

Safety is a top priority at Tronix Lighting. Therefore, we heartily recommend that you follow the following steps closely:

- Keep this manual carefully for future reference;
- Choose a qualified electrician while installing, maintaining or inspecting this product;
- Never look directly into a light source to avoid possible eye damage;
- Ensure that the respective power group is always on non-active when the product is connected;
- Use only recommended combinations (LED drivers, controllers or dimmers) to avoid injury or damage to the product;
- The light source of this light is not replaceable. Because of this, you must replace the entire fixture towards the end of its lifespan and it is not recommended to open it.

Technical problems and repair

Should a product not work properly after installation, or if the product exhibits problems over time, it is advisable to check the following elements:

- Check the wiring and installation of your product;
- Check for the presence of interfering elements such as dust, water or other electronics;
- If possible, try disconnecting the product and testing it in another location to rule out a problem at the location;
- Should you be dealing with a WIFI-based product, check and reset your router's settings.

Should the product still not work after testing, it is recommended to send it in for inspection and/or repair. To do so, please contact Tronix Lighting using nearby details and proof of purchase (packing slip).



CARE



SHARE



CONNECT

Supplier:

Tronix Lighting B.V

Vluchtoord 41
5406 XP Uden, Netherlands

+31 (0)413 330 380
sales@tronixlighting.com

Terms and symbols (as relevant to product)



The **CE mark** indicates that this product complies with EU regulations on safety, health and environmental protection;



The **WEEE symbol** stands for "Waste Electrical and Electronic Equipment Regulation," a directive on the collection, recycling and recovery of electronic waste;



The **Class I symbol** indicates that this product is protected by means of the additional ground cable. This cable is identified by the yellow/green jacket and is attached to this product.

- The product is rated **IP20**. This means that the product is resistant to the penetration of solid objects >12.5 mm and is not resistant to water or moisture.