

PacT Series
MasterPacT™ MTZ
with MicroLogic Active

Catalog 2025
Air Circuit Breakers

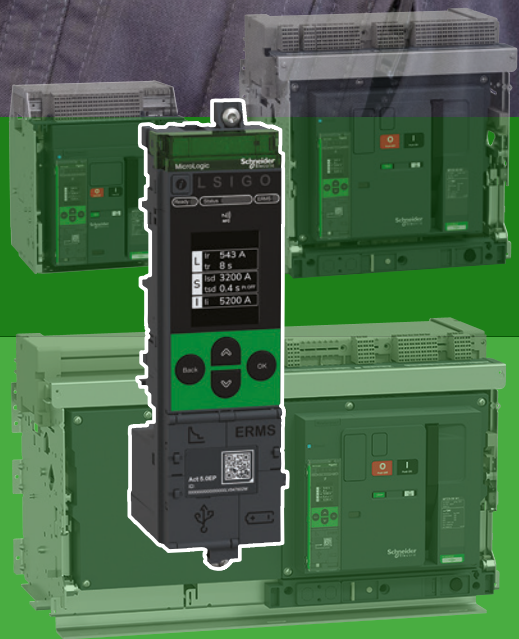

September, 2025

se.com

Life Is On

Schneider
Electric

Legal Information

The information provided in this Catalog contains description of Schneider Electric products, solutions and services ("Offer") with technical specifications and technical characteristics of the performance of the corresponding Offer.

The content of this document is subject to revision at any time without notice due to continued progress in methodology, design and manufacturing.

To the extent permitted by applicable law, no responsibility or liability is assumed by Schneider Electric and its subsidiaries for any type of damages arising out of or in connection with (i) informational content of this Catalog not conforming with or exceeding the technical specifications, or (ii) any error contained in this Catalog, or (iii) any use, decision, act or omission made or taken on basis of or in reliance on any information contained or referred to in this Catalog.

SCHNEIDER ELECTRIC MAKES NO WARRANTY OR REPRESENTATION OF ANY KIND, WHETHER EXPRESS OR IMPLIED, AS TO WHETHER THIS CATALOG OR ANY INFORMATION CONTAINED THEREIN SUCH AS PRODUCTS AND SERVICES WILL MEET REQUIREMENTS, EXPECTATIONS OR PURPOSE OF ANY PERSON MAKING USE THEREOF.

Schneider Electric brand and any trademarks of Schneider Electric and its subsidiaries referred to in this Catalog are property of Schneider Electric or its subsidiaries. All other brands are trademarks of their respective owners.

This Catalog and its content are protected under applicable copyright laws and provided for informative use only. No part of this Catalog may be reproduced or transmitted in any form or by any means (electronic, mechanical, photocopying, recording, or otherwise), for any purpose, without the prior written permission of Schneider Electric.

Copyright, intellectual, and all other proprietary rights in the content of this Catalog (including but not limited to software, audio, video, text, and photographs) rests with Schneider Electric or its licensors. All rights in such content not expressly granted herein are reserved. No rights of any kind are licensed or assigned or shall otherwise pass to persons accessing this information.

Trademarks

QR Code is a registered trademark of DENSO WAVE INCORPORATED in Japan and other countries.



MasterPacT MTZ with MicroLogic Active Ready to Act

With the emergence of Electricity 4.0 and a world that is increasingly digital and electric, customers face complex day-to-day challenges, including 24/7 uptime demands, spiraling energy costs, urgent calls for sustainable practices, and the integration of renewables.

MasterPacT MTZ with MicroLogic Active are ready to act to meet these challenges and more.

A legacy of innovation

For 35+ years, the MasterPacT name has been synonymous with circuit breaker innovation and performance.

After pioneering digital breakers more than a decade ago, MasterPacT continues to lead the way today by offering a new, intuitive control unit with innovative digital features that allow customers to achieve a new benchmark for reliability and resiliency while improving business continuity.

Energy demands are escalating

40%

Amount of available energy consumed by buildings worldwide

+50%

Level of increase in global industry energy demand by 2050

50 billion

Number of smart, connected devices by 2020

100%

Expected uptime for buildings worldwide



MasterPact

Pull

MicroLogic

Read Status ERM

In	400 A
Ird	0.5
Ith	600 A
Ig	120 A

0
Push OFF

I
Push ON

0 OFF

Schneider Electric

MTZ1-16 H1
Ui 1000V~ Uimp 12kV
Ue 220 ... 690V~
50/60 Hz

Ue (V~)	Icu (kA)
220/415/440	42
525	42
690	42

Ics = 100% Icu
Icw 42kA/1s
IEC 60947-2 cat. B

SPY01 CDF1
MTZ1 16 H1 4P FIXED

The MasterPacT MTZ range covers your protection needs

Five Performance Levels

N1 H1 H2 H3 L1

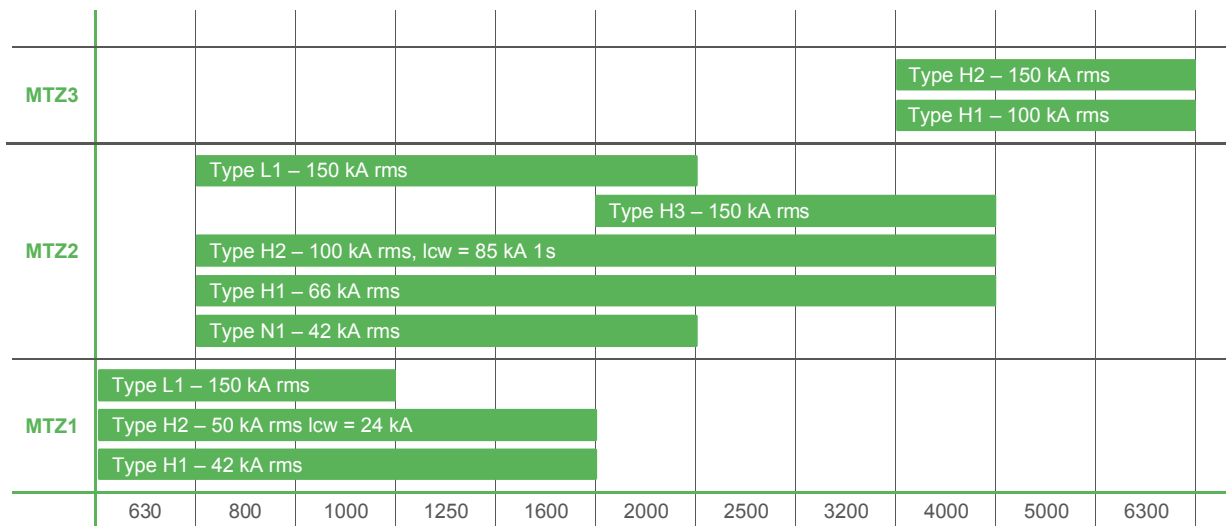



Responding to **customer challenges**

Companies across industries demand power 24/7. So when an outage occurs, they need to determine the cause quickly. Was it an overload? Short circuit? Equipment ground fault?

Knowing the root cause of an outage allows quick action to restore power and resume normal operations versus enduring lengthy and costly delays. Master**PacT** MTZ combines real-time information and ease of use to enable fast mitigation of outage events.

MasterPacT MTZ with MicroLogic Active brings more efficiency

The new Master**PacT** MTZ's innovative control unit, MicroLogic Active, monitors various breaker functions to provide vital, real-time information, which makes the Master**PacT** MTZ Active. In the event of a power outage, the breaker lets you scan a QR code on the control unit to quickly identify the cause and determine the best action to take. No need to search through a 200-page document ever again. With Master**PacT** MTZ Active, you are ready to act – fast!



Ready to act for **RELIABILITY**

MasterPacT MTZ Active features innovations to help protect electrical contractors, building occupants, maintenance personnel, and property. From its Energy Reduction Maintenance Setting to its intuitive control unit, our advanced breaker sets new benchmarks for reliable installations and operation.

Energy Reduction Maintenance Settings

(ERMS) enhance protection against arc flash hazards

Application-specific integrated circuits

(ASICs) increase IP security, improve reliability, and reduce cost

Fast-trip capability

prevents power overloads, safeguarding people and property

Intuitive control unit

allows quick setting of all protection functions



Near Field Communication

(NFC) provides remote access via a smartphone and the EcoStruxure Power Device app



Keyboard locking feature **protects parameter settings** by requiring a PIN code for user access

Color LED and LCD indicators facilitate **at-a-glance breaker status monitoring**





Ready to act for **SIMPLICITY** and **FLEXIBILITY**

With MasterPacT MTZ Active, there's no need to change your current design and installation practices – dimensions, footprint, and commissioning procedures all remain the same. And in the event of last-minute trips, you are able to respond immediately.

USB-C port allows **quick setup** and reflects latest communications best practices



User-friendly interface facilitates operation, diagnostics, and maintenance



Alarms are customizable for different applications

Note: Available soon

Field-swappable control unit allows last-minute changeouts, eliminating entire breaker replacements and avoiding project delays





Ready to act for **SUSTAINABILITY**

By partnering for sustainability with Schneider Electric through the installation of MasterPacT MTZ Active, you are helping to minimize impacts on the planet while accelerating our collective journey on the road to net zero.



Green packaging eliminates single-use plastics and features 100% recycled and recyclable cardboard

Upgrading with an MicroLogic Active control unit **extends the life of installed NT and NW breakers** and achieves carbon savings by eliminating the need to replace the entire breaker



Energy metering **tracks power consumption** and promotes energy efficiency



Ready to act for **BUSINESS CONTINUITY**

Across industries, everyone demands power 24/7. And when outages occur, customers need to determine the cause – fast. MasterPacT MTZ Active is designed allow your customers to achieve new levels of uptime and agility.



On-site Selectivity

Checks ensure power availability and maximize the business continuity

Customizable alarms* and event log contribute to uptime optimization
* Alarms customization available soon.

Algorithm-generated notifications facilitate **preventive maintenance**



Field-swappable control unit

allows last-minute changeouts, eliminating entire breaker replacements and avoiding project delays



Industry-first QR code solution

provides immediate access to the root cause of outages and advises the best action to remedy them





Active with EcoStruxure

MasterPacT MTZ Active circuit breakers are part of the Active Panel solution made possible by Schneider Electric's EcoStruxure Power architecture.

By connecting cutting-edge hardware with innovative software, Active Panels provide real-time information that enables users to pinpoint overloads and inefficiencies, make informed decisions to improve operational efficiency, and keep track of a building's electrical system status.

MasterPacT MTZ Active circuit breakers combine with Active Panels to allow:

- Connection to EcoStruxure software to unlock electrical system potential
- Remote monitoring and control with any supervision system to carry out predictive and preventive maintenance
- Remote notifications and maintenance planning with Facility Expert digital maintenance logbook
- Proactive facility management with Power Monitoring Expert, Power SCADA Operations, and Building Operation software
- Asset life-cycle management and condition-based maintenance via equipment monitoring
- Asset and alarm management
- Energy efficiency and power quality management
- Compliance with the latest regulations for energy-efficient buildings



A new digital user experience

With the MasterPacT MTZ Active circuit breaker, every stage of the project - from designing and configuring to operating and maintaining - is streamlined using its digital capabilities.

DESIGN



EcoStructure Power Design Software

Single-line diagram design software that calculates and sizes your electrical installation.

EcoStructure Power Build Software

Quick configuration and quotation tool for switchboards.

Design with 3rd Party Software

Completely integrated with third party design software to enhance your work efficiency.

CONFIGURE AND ORDER



Product Selector

Configure MasterPacT MTZ Active to save time and ensure accuracy

BUILD AND COMMISSION



EcoStructure Power Commission software

Commission and upgrade easily with protection setting and factory-acceptance test.

OPERATE AND MAINTAIN



EcoStructure Power Monitoring Software

Power Monitoring Expert
Power SCADA Operation
Building Operation
Facility Advisor

se.com

Monitor with EcoStructure Energy Hub Software

Operate with MicroLogic Active control unit

Locally in the facility room

Status "at a glance"



Remote, continuous notifications

Track facility data, receive alerts in case of power events and schedule maintenance.

se.com

Operate with your smartphone

Locally in the facility room



EcoStructure Power Device App

Android



iOS





Design Award Winner **2023**





Environmental Data Program

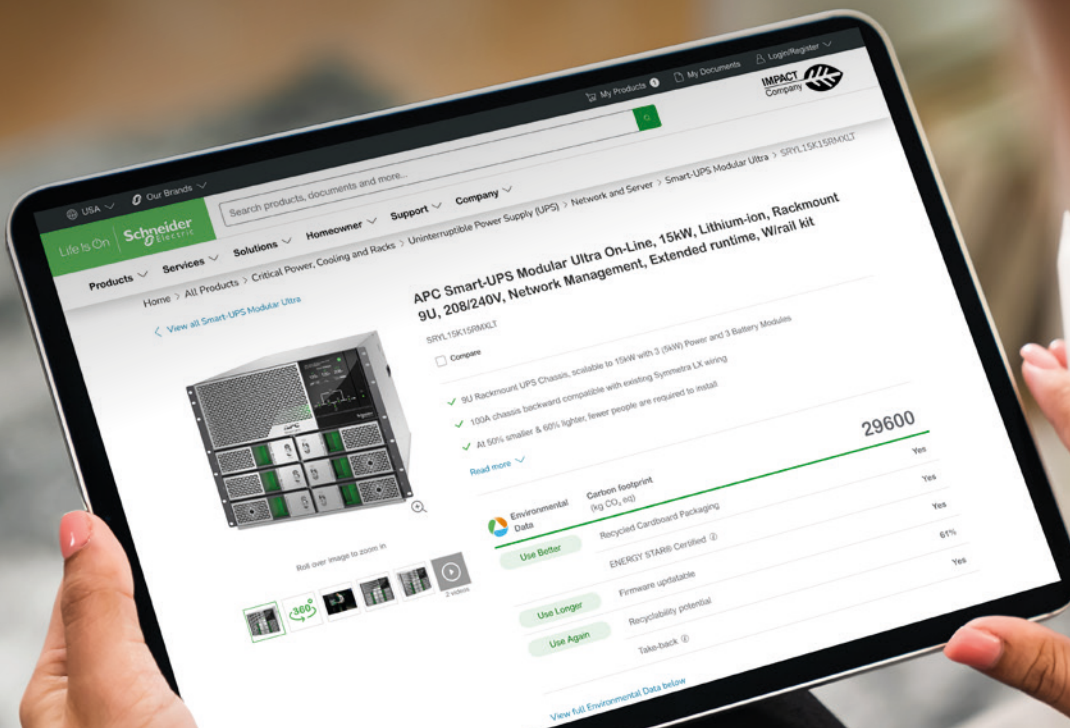

Next-level transparency for better-informed product choices

The Environmental Data Program is a framework for how we measure, categorize, and compare the environmental attributes and footprint of our products.

Using a rigorous, fact-based methodology, the program provides environmental data from across the product lifecycle.

Five data categories across the product lifecycle

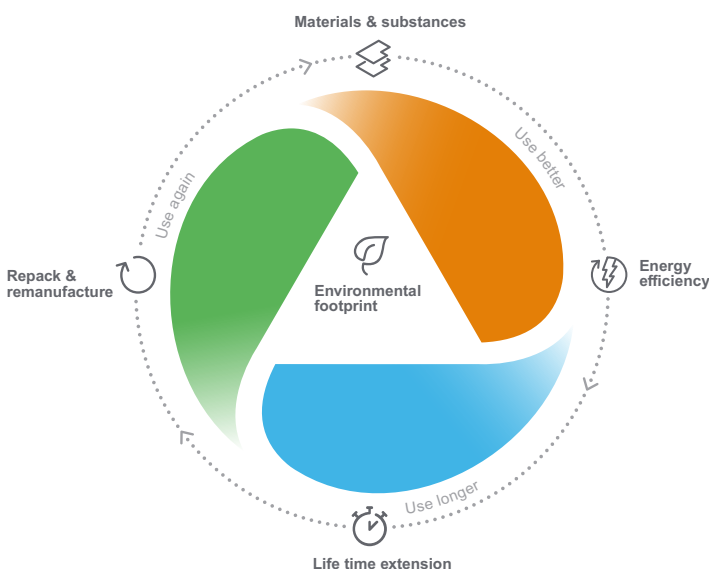

Use Better: How sustainable a product is, including environmental footprint, materials and substances, packaging, and energy efficiency.

Use Longer: How a product's life time can be effectively extended in terms of reparability and updatability.

Use Again: How a product can be reused, from dismantling and remanufacturing to recyclability and manufacturer take back.

With this transparent, verified data, customers and partners are empowered to make conscious environmental choices and accurately evaluate and report on sustainability performance.

All our hardware offers have an associated environmental data available on se.com product pages.



Learn more about the **Environmental Data Program**

General Contents

MasterPacT™ MTZ

Select a Circuit Breaker

Characteristics and performance

A

Select a MicroLogic Active Control Unit

Overview of functions

B

Customize your Circuit Breaker with Accessories

Overview, Installation simplification, Signalling, Controlling, Interlocking, Circuit protection, Operation protection, Mechanical protection, Power availability and reliability

C

Integrate in Smart Panels - Architecture and Systems

Architecture overview, Components, Customer engineering tool

D

Integrate in a Switchboard

Operating conditions, Installation rules, Temperature derating, Busbar sizing, Derating in switchboards, Dimensions, Electrical diagrams

E

Integrate in Special Applications - Source-Changeover Systems

F

Services

Overview

G

Order your Circuit Breaker

Catalog numbers, Spare parts and Product selector

H



Select a Circuit Breaker



Selection guide

Circuit breakers..... A-2
Switch-disconnectors A-4

Characteristics and performance

Circuit breakers..... A-6

Utilization category.....A-8

Other chapters

- "Select a MicroLogic Active Control Unit", page B-1
- "Customize your Circuit Breaker with Accessories", page C-1
- "Integrate in Smart Panels - Architecture and Systems", page D-1
- "Integrate in a Switchboard", page E-1
- "Integrate in Special Applications Source-Changeover Systems", page F-1
- "Services", page G-1
- "Order your Circuit Breaker", page H-1

Selection guide

Circuit breakers

A

Selection criteria

Operation

MasterPacT MTZ front face provides reinforced insulation (Class 2*) according to IEC 60664-1. It allows Class 2* installation with breaker control from outside. During battery removal, the insulation class is 1 IP2X.



PB 124025_260x280_epps

*Exception of IT network where insulation is class 1.

MasterPacT MTZ1 From 630 to 1600 A

		Type	H1	H2	L1
Rated current (A) at 40/50 °C [1]		MTZ1 06	630	630	630
		MTZ1 08	800	800	800
		MTZ1 10	1000	1000	1000
		MTZ1 12	1250	1250	
		MTZ1 16	1600	1600	
Selectivity category [2]			B	B	A
Ultimate breaking capacity V AC 50/60 Hz	Icu (kA rms) at 440 V		42	50	130
	at 525 V		42	42	100
	at 690 V [6]		42	42	-
Rated service breaking capacity	Ics (kA rms) % Icu	100%			
Rated short-time withstand current V AC 50/60 Hz	Icw (kA rms) 0.5 s		42	42	10
	1 s		42	42	-
	3 s		24	24	-
Compliant with IEC /EN 60947-2 Annex H			Yes	Yes	Yes
Position of neutral (Left: L, Right: R)			L	L	L
Type of control unit: MicroLogic Active			⊙	⊙	⊙

Installation characteristics

Type	H1	H2	L1
Connection			
Drawout, front	⊙	⊙	⊙
Drawout, rear	⊙	⊙	⊙
Fixed, front	⊙	⊙	⊙
Fixed, rear	⊙	⊙	⊙
Dimensions (mm) H x W x D			
Drawout 3P	322 x 288 x 291		
Drawout 4P	322 x 358 x 291		
Fixed 3P	301 x 276 x 209		
Fixed 4P	301 x 346 x 209		
Weight (kg) approximate			
Drawout 3P/4P	30/39		
Fixed 3P/4P	14/18		

[1] 50 °C only for circuit breakers with rear vertical connections, refer to temperature derating tables for other connection types.

[2] For details on selectivity category A and B, see page A-8.

[3] No front connection for 4000 A.

[4] No horizontal rear connection for 6300 A.

[5] To be specified when ordering.

[6] For IT grounding systems, the rating is limited to 600 V AC. For more information, please contact Schneider Electric Customer Care Center.



PB124023_295x295.eps

MasterPacT MTZ2
From 800 to 4000 A



PB124028_461x461.eps

MasterPacT MTZ3
From 4000 to 6300 A

Type	N1	H1		H2		H3	L1	Type	H1	H2	
MTZ2 08	800	800		800			800				
MTZ2 10	1000	1000		1000			1000				
MTZ2 12	1250	1250		1250			1250				
MTZ2 16	1600	1600		1600			1600				
MTZ2 20	2000	2000			2000	2000	2000				
MTZ2 25			2500		2500	2500					
MTZ2 32			3200		3200	3200					
MTZ2 40			4000		4000	4000		MTZ3 40	4000	4000	
								MTZ3 50	5000	5000	
								MTZ3 63	6300	6300	
	B	B		B		B	B		B	B	
	42	66		100		150	150		100	150	
	42	66		85		130	130		100	130	
	42	66		85		100	100		100	100	
	100%							100%			
	42	66	66	85	85	65	30		100	100	
	42	66	66	85	85	65	30		100	100	
	22	36	66	50	75	65	30		100	100	
	Yes	Yes		Yes		Yes	Yes		Yes	Yes	
	L	L or R ^[5]		L or R ^[5]		L	L		L or R ^[5]	L or R ^[5]	
	<input checked="" type="radio"/>	<input checked="" type="radio"/>		<input checked="" type="radio"/>		<input checked="" type="radio"/>	<input checked="" type="radio"/>		<input checked="" type="radio"/>	<input checked="" type="radio"/>	

Dimensions and Mounting

	N1	H1	H2	H3	L1	H1	H2
	<input checked="" type="radio"/>	<input checked="" type="radio"/> ^[3]	<input checked="" type="radio"/> ^[3]	<input checked="" type="radio"/> ^[3]	<input checked="" type="radio"/>	<input type="radio"/>	<input type="radio"/>
	<input checked="" type="radio"/>	<input checked="" type="radio"/>	<input checked="" type="radio"/>	<input checked="" type="radio"/>	<input checked="" type="radio"/>	<input checked="" type="radio"/> ^[4]	<input checked="" type="radio"/> ^[4]
	<input checked="" type="radio"/>	<input checked="" type="radio"/> ^[3]	<input checked="" type="radio"/> ^[3]	<input type="radio"/>	<input type="radio"/>	<input type="radio"/>	<input type="radio"/>
	<input checked="" type="radio"/>	<input checked="" type="radio"/>	<input checked="" type="radio"/>	<input type="radio"/>	<input type="radio"/>	<input checked="" type="radio"/> ^[4]	<input checked="" type="radio"/> ^[4]

439 x 441 x 403	479 x 786 x 403
439 x 556 x 403	479 x 1016 x 403
352 x 422 x 300	352 x 767 x 300
352 x 537 x 300	352 x 997 x 300
90/120	225/300
50/65	120/160

Select a Circuit Breaker

Selection guide

Switch-disconnectors

A

Selection criteria

Safety of operation

MasterPacT MTZ front face provides reinforced insulation (Class 2) according to IEC 60664-1.

It allows Class 2 installation with breaker control from outside.



MasterPacT MTZ1

From 630 to 1600 A

Type	Type	HA
Rated current (A) at 40/50 °C ^[1]	MTZ1 06	630
	MTZ1 08	800
	MTZ1 10	1000
	MTZ1 12	1250
	MTZ1 16	1600

Switch-disconnector (as per IEC/EN 60947-3)

Rated making capacity V AC 50/60 Hz	I_{cm} (kA)	at 440 V	75
		at 690 V	75
		at 1150 V	-
Rated short-time withstand current V AC 50/60 Hz	I_{cw} (kA rms) 1 s		36
Utilisation category ^[2]			AC-23A

Unprotected circuit breaker (tripping by shunt trip as per IEC/EN 60947-2)

External protection relay: short-circuit protection, maximum delay: 400 ms ^[2]

Ultimate breaking capacity V AC 50/60 Hz	I_{cu} (kA rms)	at 440 V	-
		at 690 V	-
Rated service breaking capacity	I_{cs} (kA rms) % I_{cu}		-
Rated short-time withstand current V AC 50/60 Hz	I_{cw} (kA rms)	1 s	-
		3 s	-
Rated making capacity V AC 50/60 Hz	I_{cm} (kA)	at 440 V	
		at 690 V	

Position of neutral (Left: L, Right: R)	L or R
---	--------

Installation characteristics

Type	HA
Connection	
Drawout, front	⊙
Drawout, rear	⊙
Fixed, front	⊙
Fixed, rear	⊙
Dimensions (mm) H x W x D	
Drawout 3P	322 x 288 x 291
Drawout 4P	322 x 358 x 291
Fixed 3P	301 x 276 x 209
Fixed 4P	301 x 346 x 209
Weight (kg) approximate	
Drawout 3P/4P	30/39
Fixed 3P/4P	14/18

[1] 50 °C for rear vertical connected only, refer to temperature derating tables for other connection types.

[2] For details on unprotected circuit breaker and utilisation category AC-23A, see page A-10.

[3] No front connection for 4000 A.

[4] No horizontal rear connection for 6300 A.

[5] MTZ2 HA10 dedicated to 1150 V systems.

[6] For MaterPact MTZ2 HH the rated operational voltage is limited to 440 V AC - 50/60 Hz.

Select a Circuit Breaker

Selection guide

Switch-disconnectors

A



FE12A02_20000000

MasterPacT MTZ2
From 800 to 4000 A



FE12A03_40000000

MasterPacT MTZ3
From 4000 to 6300 A

Type	NA	HA	HF	HH ^[6]	HA10 ^[5]	Type	HA
MTZ2 08	800	800	800		800		
MTZ2 10	1000	1000	1000		1000		
MTZ2 12	1250	1250	1250		1250		
MTZ2 16	1600	1600	1600		1600		
MTZ2 20		2000	2000	2000	2000		
MTZ2 25		2500	2500	2500	2500		
MTZ2 32		3200	3200	3200	3200		
MTZ2 40		4000	4000	4000	4000	MTZ3 40	4000
						MTZ3 50	5000
						MTZ3 63	6300

	88	145	187	220	-		
	88	145	187	-	-		187
	-	-	-	-	105		-
	42	66	85	100	50		85
	AC-23A	AC-23A	AC-23A	AC-23A	AC-23A		AC-23A

	-	66	85	100	-		85
	-	66	85	-	-		85
	-	100 %	100 %	100 %	-		100 %
	-	66	85	100	-		85
	-	36	75	75	-		85
	-	145	187	220	-		187
	-	145	187	-	-		187
	L or R	L or R	L or R	L or R	L or R		L

	NA	HA	HF	HH	HA10		HA
	<input checked="" type="radio"/>	<input checked="" type="radio"/> ^[3]	<input checked="" type="radio"/> ^[3]	<input checked="" type="radio"/> ^[3]	<input type="radio"/>		<input type="radio"/>
	<input checked="" type="radio"/>	<input checked="" type="radio"/>	<input checked="" type="radio"/>	<input checked="" type="radio"/>	<input checked="" type="radio"/>		<input checked="" type="radio"/> ^[4]
	<input checked="" type="radio"/>	<input checked="" type="radio"/> ^[3]	<input checked="" type="radio"/> ^[3]	<input checked="" type="radio"/> ^[3]	<input type="radio"/>		<input type="radio"/>
	<input checked="" type="radio"/>	<input checked="" type="radio"/>	<input checked="" type="radio"/>	<input checked="" type="radio"/>	<input checked="" type="radio"/>		<input checked="" type="radio"/> ^[4]

439 x 441 x 403	479 x 786 x 403
439 x 556 x 403	479 x 1016 x 403
352 x 422 x 300	352 x 767 x 300
352 x 537 x 300	352 x 997 x 300

90/120	225/300
50/65	120/160

Characteristics and performance

Circuit breakers

A

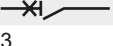
Common characteristics	MTZ1	MTZ2 & MTZ3
Number of poles	3/4	3/4
Rated insulation voltage U_i (V)	1000	1000
Impulse withstand voltage U_{imp} (kV)	12	12
Rated operational voltage U_e (V AC 50/60 Hz)	690	690
Suitability for isolation	IEC/EN 60947-2	
Degree of pollution	IEC/EN 60947-1	3

Characteristics

MasterPacT MTZ1 From 630 to 1600 A

Circuit breaker as per IEC/EN 60947-2

MasterPacT			06	08	10	12	16
Rated current at 40/50 °C ^[1]	I_n (A)		630	800	1000	1250	1600
Sensor ratings	(A)		400 to 630	400 to 800	400 to 1000	400 to 1250	400 to 1600
MasterPacT			06 to 10			12 to 16	
Type			H1	H2	L1 ^[2]	H1	H2
Ultimate breaking capacity V AC 50/60 Hz	I_{cu} (kA rms)	220/415 V	42	50	150	42	50
		440 V	42	50	130	42	50
		500/525 V	42	42	100	42	42
		660/690 V	42	42	-	42	42
Rated service breaking capacity	I_{cs} (kA rms)	% I_{cu}	100	100	100	100	100
Selectivity category ^[3]			B	B	A	B	B
Rated short-time withstand current V AC 50/60 Hz	I_{cw} (kA rms)	0.5 s	42	42	10	42	42
		1 s	42	42	-	42	42
		3 s	24	24	-	24	24
Rated making capacity V AC 50/60 Hz	I_{cm} (kA)	220/415 V	88	105	330	88	105
		440 V	88	105	286	88	105
		500/525 V	88	88	220	88	88
		660/690 V	88	88	52	88	88
Integrated instantaneous protection (DIN kA instantaneous $\pm 10\%$) ^[3]			-	90	10 x I_n	-	90
Break time between tripping order and arc extinction	(ms)		25	25	9	25	25
Closing time	(ms)		< 50			< 50	

Durability as per IEC/EN 60947-2/3

Mechanical durability ^[4]		MTZ1 06 to 10			MTZ1 12 to 16	
Mechanical durability, C/O cycles x 1000 with periodic preventive maintenance		12.5	12.5	12.5	12.5	12.5
Electrical durability ^[4] at rated current I_n		MTZ1 06 to 10 630 to 1000 A			MTZ1 12 to 16 1250 to 1600 A	
Type of MasterPacT		H1	H2	L1	H1	H2
Electrical durability, C/O cycles x 1000 IEC/EN 60947-2	440 V	6	6	3	6	6
	690 V	3	3	2	3	3
Electrical durability ^[4] at rated operational current I_e in AC-23A ^[3]		MTZ1 06 to 12 630 to 1250 A			MTZ1 16 1600 A	
Type of MasterPacT		H1	H2		H1	H2
Electrical durability, C/O cycles x 1000 IEC/EN 60947-3	440 V	6	6		6	6
	690 V	3	3		3	3
Electrical durability ^[4] at rated operational current I_e in AC-3 ^[3]		MTZ1 06 to 10 500 A			800 A	
Type of MasterPacT		H1/H2				
Motor power (kW)	380/415 V	≤ 250			335 to 450	
	440 V	≤ 300			400 to 500	
	690 V	-			-	
Electrical durability, C/O cycles x 1000 IEC/EN 60947-3 and IEC/EN 60947-4-1	440 V	6				
	690 V	-				

[1] 50 °C: only for circuit breakers with rear vertical connections. Refer to temperature derating tables for other connection types.

[2] See the current-limiting curves in the "additional characteristics" section

[3] For details on selectivity categories A, B, AC-3, AC-23A and DIN-DINF, see page A-8.

[4] The term *durability* is used to express the expected number of operating cycles which can be performed by the device.

Characteristics and performance

Circuit breakers

A

Sensor selection													
Sensor rating I _n (A)	400	630	800	1000	1250	1600	2000	2500	3200	4000	5000	6300	
I _r threshold setting(A)	160 to 400	250 to 630	320 to 800	400 to 1000	500 to 1250	630 to 1600	800 to 2000	1000 to 2500	1250 to 3200	1600 to 4000	2000 to 5000	2500 to 6300	

MasterPacT MTZ2 From 800 to 4000 A	MasterPacT MTZ3 From 4000 to 6300 A
--	---

08				10				12				16				20				25				32				40				40				50				63			
800				1000				1250				1600				2000				2500				3200				4000				4000				5000				6300			
400 to 800				400 to 1000				400 to 1250				400 to 1600				400 to 2000				1250 to 2500				1250 to 3200				1250 to 4000				2000 to 4000				2000 to 5000				2000 to 6300			
08 to 16																20				25 to 40								40 to 63															
N1	H1	H2	L1 [2]	N1	H1	H2	L1 [2]	N1	H1	H2	H3	L1 [2]	H1	H2	H3	H1	H2	H3	H1	H2																							
42	66	100	150	42	66	100	150	42	66	100	150	150	66	100	150	66	100	150	66	100	150	100	150																				
42	66	100	150	42	66	100	150	42	66	100	150	150	66	100	150	66	100	150	66	100	150	100	150																				
42	66	85	130	42	66	85	130	42	66	85	130	130	66	85	130	66	85	130	66	85	130	100	130																				
42	66	85	100	42	66	85	100	42	66	85	100	100	66	85	100	66	85	100	66	85	100	100	100																				
100	100	100	100	100	100	100	100	100	100	100	100	100	100	100	100	100	100	100	100	100	100	100	100																				
B	B	B	B	B	B	B	B	B	B	B	B	B	B	B	B	B	B	B	B	B	B	B	B																				
42	66	85	30	42	66	85	30	42	66	85	30	30	66	85	65	30	66	85	65	30	66	85	65	30																			
42	66	85	30	42	66	85	30	42	66	85	30	30	66	85	65	30	66	85	65	30	66	85	65	30																			
22	36	50	30	22	36	75	30	22	36	75	30	30	66	75	65	30	66	75	65	30	66	75	65	30																			
88	145	220	330	88	145	220	330	88	145	220	330	330	145	220	330	330	145	220	330	330	145	220	330	330																			
88	145	220	330	88	145	220	330	88	145	220	330	330	145	220	330	330	145	220	330	330	145	220	330	330																			
88	145	187	286	88	145	187	286	88	145	187	286	286	145	187	286	286	145	187	286	286	145	187	286	286																			
88	145	187	220	88	145	187	220	88	145	187	220	220	145	187	220	220	145	187	220	220	145	187	220	220																			
-	-	190	80	-	-	190	80	-	-	190	150	80	-	190	150	80	-	190	150	80	-	190	150	80																			
25	25	25	10	25	25	25	10	25	25	25	10	10	25	25	25	10	25	25	25	10	25	25	25	10																			
< 70				< 70				< 70				< 70				< 70				< 70				< 70				< 70															

MTZ2 08 to 16	MTZ2 20	MTZ2 25 to 40	MTZ3 40 to 63
25	20	20	10
MTZ2 08 to 16 800 to 1600 A	MTZ2 20 2000 A	MTZ2 25 to 40 2500 to 4000 A	MTZ3 40 to 63 4000 to 6300 A
N1/H1/H2 L1	N1/H1/H2 H3 L1	H1/H2	H1 H2
10 3	8 2 3	5	1.5 1.5
10 3	6 2 3	2.5	1.5 1.5
MTZ2 08 to 16 800 to 1600 A	MTZ2 20 2000 A	MTZ2 25 to 40 2500 to 4000 A	MTZ3 40 to 63 4000 to 6300 A
H1/H2	H1/H2/H3	H1/H2/H3	H1 H2
10	8	5	1.5 1.5
10	6	2.5	1.5 1.5
MTZ2 08 to 16 800 A	MTZ2 20 2000 A		
H1	H1/H2/H3		
335 to 450 560 to 670	900 to 1150	-	-
400 to 500 500 to 800	1000 to 1300	-	-
≤ 800 1000 to 1250	1600 to 2000	-	-
6	6	-	-
6 for H1/H2	6	-	-

Select a Circuit Breaker

Utilization category

A

Selectivity Categories A and B (IEC/EN 60947-2)

The selectivity category is defined by the IEC/EN 60947-2:2013 standard:

■ Selectivity category A

Circuit breakers not specifically intended for selectivity under short-circuit conditions with respect to other short-circuit protective devices in series on the load side, i.e. without an intentional short-circuit delay provided for selectivity under short-circuit conditions, and therefore without a short-circuit withstand current rating according to 4.3.5.4.

■ Selectivity category B

Circuit breakers specifically intended for selectivity under short-circuit conditions with respect to other short-circuit protective devices in series on the load side, i.e. with an intentional short-circuit delay (which may be adjustable), provided for selectivity under short-circuit conditions. Such circuit breakers have a short-circuit withstand current rating according to 4.3.5.4.

The selectivity between MasterPacT MTZ category B circuit breakers is certified up to the rated short-time withstand current (I_{cw}).

When $I_{cu} > I_{cw}$, the circuit breakers integrate an instantaneous override protection (DIN) which operates above I_{cw} .

On top of the selectivity category, the selectivity performance between 2 circuit breakers depends on the type of MicroLogic Active control units and the settings of these control units. Please refer to the selectivity tables in the Complementary Technical Guide or to the Schneider Electric calculation tools.

DIN-DINF

MasterPacT MTZ circuit breakers integrate two types of instantaneous short-circuit protection:

- 1: A *DIN* (Instantaneous override protection) active when the circuit breaker is closed. The DIN is activated above I_{cw} . It operates on the instantaneous value of the current.
- 2: A *DINF* (Instantaneous making over-current voltage release) intended to instantaneously trip the circuit breaker in case of closing on a short-circuit current higher than its threshold. The DINF operates on the instantaneous value of the current. The DINF is disabled around 50 ms after the circuit breaker closing.

Utilization Category AC-23A

Defined in standard for Switches (IEC/EN 60947-3); applies to devices specifically intended for the switching of motor loads or other highly inductive loads.

Utilization categories with suffix A (e.g. AC-23A) designate devices which are intended for frequent operation. The corresponding number of operating cycles with the associated operational currents are specified in Table 4 of IEC/EN 60947-3.

Utilization Category AC-3

Defined in the standard for contactors and motor starters (IEC/EN 60947-4-1); applies to devices specifically intended for the switching of asynchronous squirrel-cage motors.

Select a MicroLogic Active Control Unit

Overview of functions.....	B-2
Protections	
Protection functions	B-10
ERMS - Energy Reduction Maintenance Settings....	B-15
Protections	
Tripping curves	B-16
Limitation curves	B-19
Measurement.....	B-20
Maintenance and diagnostics	B-21
Event management	B-25
Power supply	B-27



Other chapters
"Select a Circuit Breaker", page A-1
"Customize your Circuit Breaker with Accessories", page C-1
"Integrate in Smart Panels - Architecture and Systems", page D-1
"Integrate in a Switchboard", page E-1
"Integrate in Special Applications Source-Changeover Systems", page F-1
"Services", page G-1
"Order your Circuit Breaker", page H-1

B

Measurement

Energy management is the challenge of present and future generations. To meet this requirement, MicroLogic Active incorporates all the measuring functions.

Maintenance and Diagnostics

Optimal continuity of services as well as extended equipment life are among customers main concerns. For that purpose, MicroLogic Active control units contribute to corrective, preventive and predictive maintenance.

Protection

MicroLogic Active offers a large long-time delay setting range and protection accuracy for a wide temperature range (-25 to +70 °C).



Communication

- It is now common practice to make available most of the information processed by a protection control unit, both locally for network operation and maintenance, and remotely for higher functions of control, monitoring, energy efficiency and asset management.
- To comply with this requirement, MicroLogic Active control units **incorporate several channels of communication, including Ethernet, Modbus SL and wireless communication interfaces.**

MicroLogic Name Codes

2.0 EP

Protection type

- 2.0 Basic Protection (LI - Long Time and Instantaneous Protection)
- 5.0 Selective Protection (LSI)
- 6.0 Selective Protection (LSI) + Ground Fault Protection

Communication

P for "PowerTag function", control unit with wireless communication

Measurement type

- A for "ammeter"
- E for "power and energy meter"

> Protection for ...

... MicroLogic Active 2.0

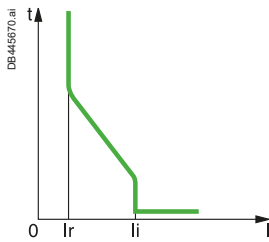

LI: Long-time
+ Instantaneous



> Additional features of protections (page B-9)

Along with the LSIG protections, new additional features and communication interfaces improve the protection performance of a system to manage difficulties such as low short-circuit current values or the need to limit the thermal constraints of the equipment: fine settings, zone selective interlock.

... MicroLogic Active 5.0

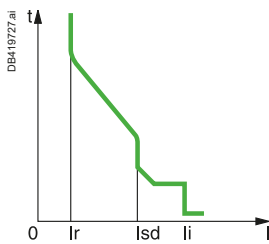

LSI: Long-time
+ Short-time
+ Instantaneous



> Measurement (page B-20)

MicroLogic Active measures all electrical parameters of an electrical network: currents, voltages, frequency, power, energy, power factor, current and power demand. Min/Max and average values are calculated for most of the parameters.

... MicroLogic Active 6.0

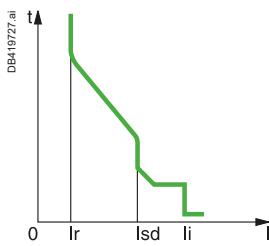

LSIG: Long-time
+ Short-time
+ Instantaneous
+ Ground fault

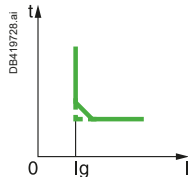

> Maintenance and Diagnostics (page B-21)

Diagnostic features are intended to limit the risk of power interruptions and to power up the installation as quickly as possible after a trip. They provide alarms and messages to help the user in scheduling both preventive and predictive maintenance, as well as device replacement.

> Communication (page D-1)

The new generation of MicroLogic Active control units incorporate Zigbee and optional Bluetooth [1] that allows the user to send a wide selection of information (protection, measurements, maintenance and diagnostics data) to your mobile device, by means of the EcoStruxure Power Device app. Alternatively, MasterPacT MTZ can be equipped with Ethernet communication through either an IFE module or an embedded EIFE, with webpage visualization. Modbus SL communication is available through the IFM interface module.

[1] Available soon.

MasterPacT MTZ

- > Makes power available and reliable in a range of application and operating conditions.
- > Incorporates the latest technology to enhance both performance and safety.

B

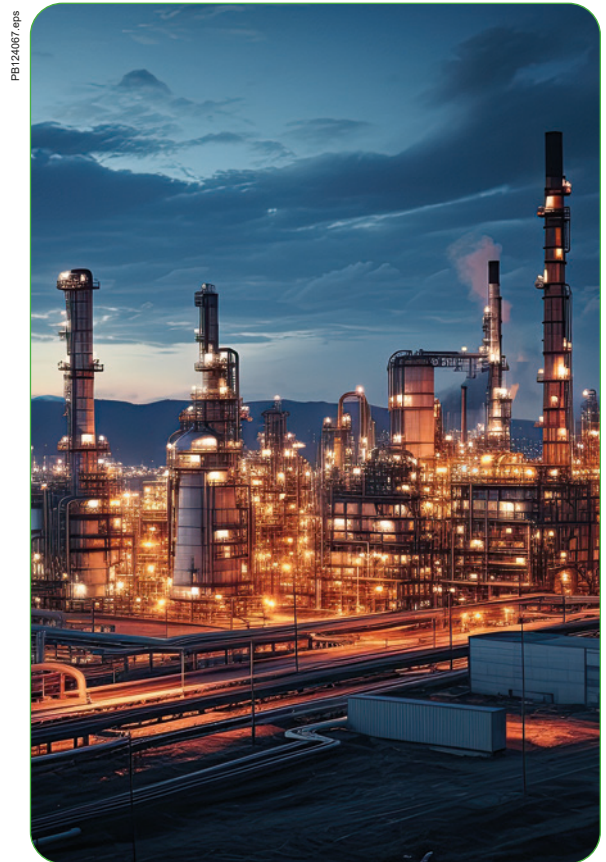

<h3>Protection</h3> 	<h3>MicroLogic Active A/AP</h3> <p>Basic protections</p> <ul style="list-style-type: none"> ● Long-time ● Short-time ● Instantaneous ● Ground fault <p>Zone Selectivity Interlocking Trip History Settings tracability</p> <p>> See page B-9</p>	<h3>MicroLogic Active E/EP</h3> <p>+ Advanced protections</p> <ul style="list-style-type: none"> ● ANSI 27 (Undervoltage) ● ANSI 59 (Overvoltage)
---	--	--

<h3>Measurement</h3> 	<h3>MicroLogic Active A/AP</h3> <ul style="list-style-type: none"> ● Currents <p>> See page B-20</p>	<h3>MicroLogic Active E/EP</h3> <p>Additional values:</p> <ul style="list-style-type: none"> ● Current demand ● Voltages ● Power ● Energy ● Frequency
---	--	---

<h3>Maintenance & diagnostics</h3> 	<ul style="list-style-type: none"> ● Predictive maintenance ● Local maintenance ● Local breaker health status ● Contact wear ● Operation counter ● Trip cause and records <p>> See page B-21</p>	
--	---	--

<h3>Communication</h3> 	<ul style="list-style-type: none"> ● Zigbee and Bluetooth^[1] (MicroLogic Active AP/EP) ● Modbus wired communication (Accessories) ● NFC (All variants except Micrologic Active Ei) ● Metering, alarm information ● USB interface with EcoStruxure Power Commission (EPC) and EcoStruxure Power Device (EPD) <p>[1] Available soon.</p> <p>> See page D</p>	
--	---	--

Select a MicroLogic Active Control Unit

Overview of functions

All MasterPacT circuit breakers are equipped with a MicroLogic control unit that can be changed on site. Control units are designed to protect Power circuits and loads. Alarms may be programmed for remote indications. Measurements of current, voltage, frequency, power and power quality optimise continuity of service and energy management.

B

Dependability

Integration of protection functions in an ASIC electronic component used in all MicroLogic control units guarantees a high degree of reliability and immunity to conducted or radiated disturbances.

On MicroLogic Active A and E control units, advanced functions are managed by an independent microprocessor.

Accessories

Certain functions require the addition of MicroLogic control unit accessories, described on [page C-2](#).

The rules governing the various possible combinations can be found in the documentation accessible via the Products and services menu of the www.schneider-electric.com web site.

Select a MicroLogic Active Control Unit

Overview of functions

The functions of protection...

...included in the control unit are designed to comply with electrical installation rules providing overcurrent and short-circuit protection.

MicroLogic Active 6.0 provides ground-fault protection. Embedded metering functions offer the measurement parameters required to optimize energy management.

The control unit proposes embedded functions of protection, measurement and maintenance and diagnostics.

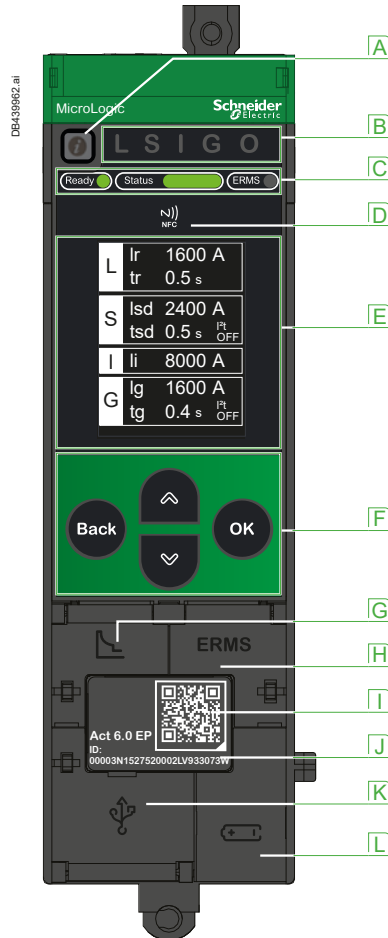

All the information processed and stored by the MicroLogic Active control unit is accessible on:

- Embedded HMI with colored backlight,
- Smartphones via USB (optional) and NFC communication,
- External PC through a USB connection.

EIFE and IFE interface modules enable Ethernet connection to the breaker.

Connection to Modbus SL using IFM interface module.



- A** i button for Information/Test/Reset
- B** Trip cause LEDs
- C** Status LEDs:
 - Ready LED
 - Status bar
 - ERMS LED

- D** NFC wireless communication zone
- E** Graphic display screen
- F** Navigation buttons
- G** Button for direct access to protection settings

- H** Button for direct access to ERMS
- I** QR code to access product information
- J** Control unit type and identification number
- K** USB-C port
- L** Internal battery drawer module

Note: Certain functions of the MicroLogic Active control unit require additional accessories and interface modules as described in chapter C.

Select a MicroLogic Active Control Unit

Overview of functions

B

MicroLogic Active ensures a high degree of reliability and immunity to conducted and radiated disturbances with its enhanced internal architecture including a dedicated ASIC electronic component for the protection functions. A high level of diagnostics makes it possible to monitor the health of the circuit breaker in real time. With its embedded backlight HMI and its LED status bar, MicroLogic Active enables alarm messages to be quickly identified.

The information processed by the MicroLogic Active may be displayed on the embedded backlight HMI, a smartphone via USB or NFC, and a PC through USB connection.

The connection to Ethernet is achieved by means of an EIFE and IFE interface modules.

The connection to Modbus SL is achieved by means of an IFM interface module.

A wide range of accessories can be used to improve the functions of control and monitoring.

DB445861.ai

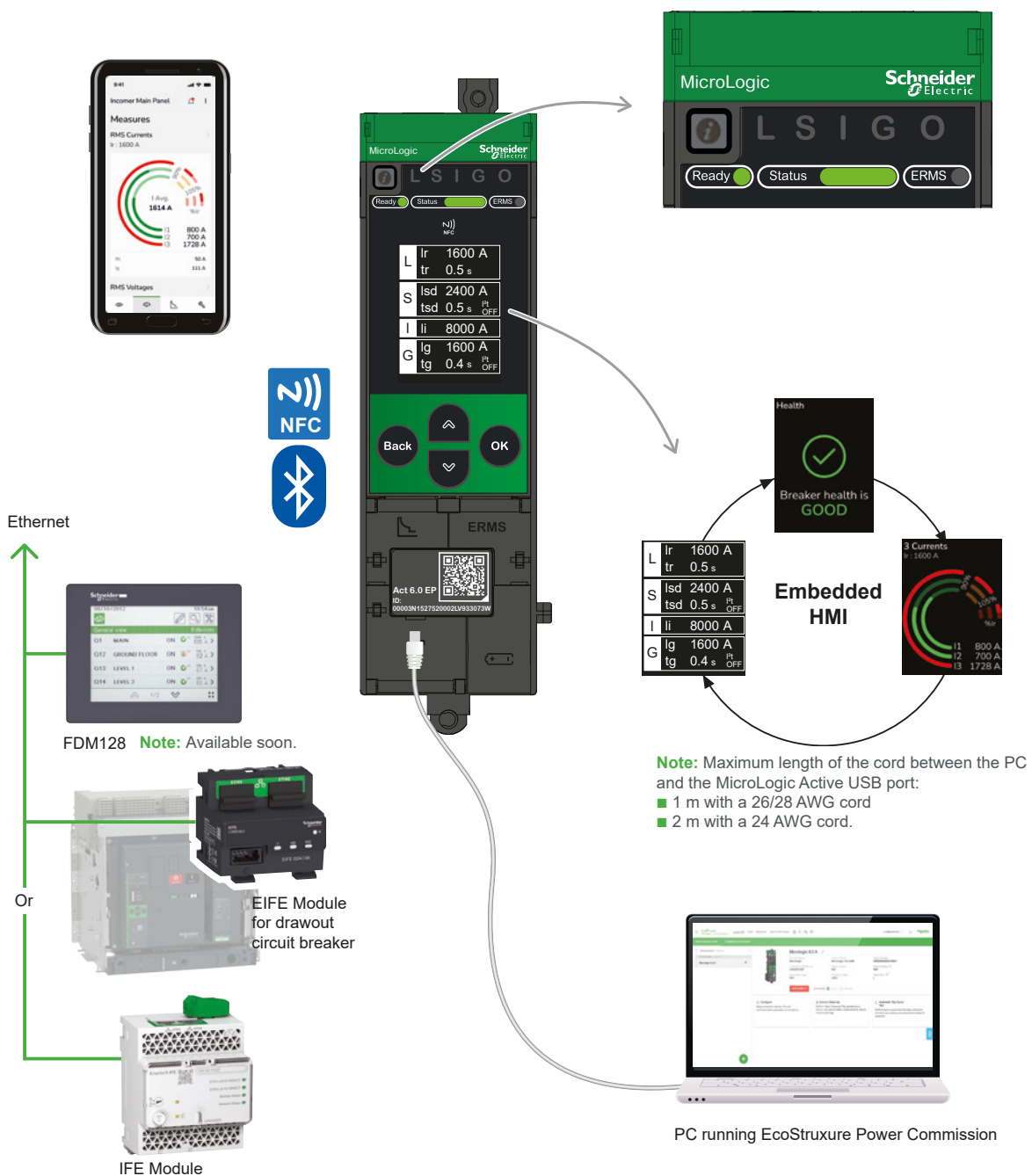

Protections

Protection functions

B

The MicroLogic Active control unit is suitable for different systems of voltage, three or four wires up to 690 V AC, 50/60 Hz and for all grounding systems as defined per IEC or North American standards (TNC, TNS, TT, IT, HRG).

Protection Description

L Overloads: Long Time Protection

Inverse time protection against overloads with an adjustable current pick-up I_r set using a dial or the keypad for fine adjustments. The time delay t_r is set using the keypad.

S Short-Circuits: Short-Time Protection

Short-circuit protection with an adjustable pick-up I_{sd} and adjustable time delay t_{sd} , with the possibility of including a portion of an inverse time curve (I^2t On).

I Short-Circuits: Instantaneous Protection

Instantaneous protection with adjustable pick-up I_i .

G Ground Fault Protection

Residual type ground-fault protection with an adjustable pick-up I_g (with Off position) and adjustable time delay t_g . Possibility of including a portion of an inverse time curve (I^2t On).

MicroLogic Active 2.0

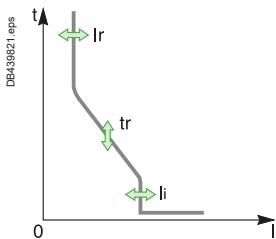

L Long-time		ANSI 49RMS/51										
Current setting (A)	$I_r = I_n \times \dots$	$I_r = 0.4 I_n$ to I_n , 1 A step										
Time setting		Tripping between 1.05 and 1.20 I_r										
Time setting exemple: time delay (s)		$t_r = 0.5$ s to 24 s for MTZ1, and to 30 s for MTZ2/3, 0.5 s step for 6 I_r										
	Accuracy: 0 to -30 %	1.5 x I_r	12.5	25	50	100	200	300	400	500	600	750
	Accuracy: 0 to -20 %	6 x I_r	0.5 ^[1]	1	2	4	8	12	16	20	24	30 ^[4]
	Accuracy: 0 to -20 %	7.2 x I_r	0.34 ^[2]	0.69	1.38	2.7	5.5	8.3	11	13.8	16.6	20.9
Thermal memory		After tripping										
I Instantaneous		ANSI 50										
Pick-up (A)	$I_i = I_r \times \dots$	$I_i = 1.5$ to $10 I_r$, 0.1 I_r step										
Accuracy: ±10 %												
Operating time (ms)		Non-tripping time: 20 Max breaking time: 80										

[1] 0 to -40 %
[2] 0 to -60 %

[4] Only for MTZ2 and MTZ3

Protections

Protection functions

B

MicroLogic Active 5.0 - 6.0

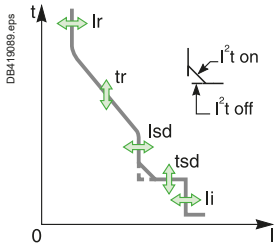

L Long-time ANSI 49RMS/51

Current setting (A)	$I_r = I_n \times \dots$	$I_r = 0.4 I_n$ to I_n , 1 A step										
Time setting		Tripping between 1.05 and 1.20 x I_r										
Time setting example: time delay (s)	Accuracy: 0 to -30 %	1.5 x I_r	12.5	25	50	100	200	300	400	500	600	750
	Accuracy: 0 to -20 %	6 x I_r	0.5 ^[1]	1	2	4	8	12	16	20	24	30 ^[4]
	Accuracy: 0 to -20 %	7.2 x I_r	0.34 ^[2]	0.69	1.38	2.7	5.5	8.3	11	13.8	16.6	20.9
Thermal memory		After tripping										

S Short-time ANSI 50TD/51

Pick-up (A)	$I_{sd} = I_r \times \dots$	$I_{sd} = 1.5 I_r$ to $10 I_r$, 0.1 I_r step										
Accuracy: ±10 %												
Time setting tsd (s)	Settings	I^2t Off	0	0.1	0.2	0.3	0.4	0.6	0.8			
		I^2t On	-	0.1	0.2	0.3	0.4	0.6	0.8			
Operating time at 10 x I_r	non-tripping time (ms)	20	80	140	230	350	550	710				
I^2t Off or I^2t On	max breaking time (ms)	80	140	200	320	500	630	800				

I Instantaneous ANSI 50

Pick-up (A)	$I_i = I_n \times \dots$	$I_i = 2 I_n$ to $15 I_n$, 0.1 I_n step and OFF protection	
Accuracy: ±10 %			
I_i tripping mode		Standard	FAST (ERMS only)
Operating time	non-tripping time (ms)	20	0
	max breaking time (ms)	50	30

MicroLogic Active 6.0

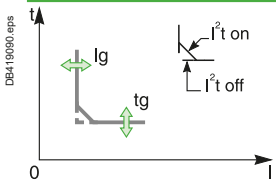

G Ground fault ANSI 50N-TD/51N

Pick-up (A)	$I_g = I_n \times \dots$	$I_g = 0.2$ ^[3] I_n to I_n , 1 A step for $I_n \leq 1000$ A and 10 A step for $I_n > 1000$ A and OFF protection										
Accuracy: ±10 %												
Time setting t_g (s)	Settings	I^2t Off	0	0.1	0.2	0.3	0.4	0.6	0.8	1		
		I^2t On	-	0.1	0.2	0.3	0.4	0.6	0.8	1		
Operating time	non-tripping time (ms)	20	80	140	230	350	550	710	900			
	max breaking time (ms)	80	140	200	320	500	630	800	1000			

[1] 0 to -40 %

[2] 0 to -60 %

[3] 0.3 I_n to I_n for $I_n \leq 400$ A

[4] Only for MTZ2 and MTZ3

Protections

Protection functions

The characteristics of the protection provide full selectivity for the majority of applications with all types of ComPacT circuit breakers as well as between MasterPacT circuit breakers, even for high short-circuit currents. Fine setting, and zone-selective interlocking make it possible to improve the performance of the low-voltage protection systems.

Protection functions

The following functions of protection are available, depending of the type of MicroLogic Active selected: long-time overload protection, short-time short-circuit protection, instantaneous short-circuit protection, and ground fault protection. All these protections operate without an auxiliary power supply. They are powered by the currents flowing through the circuit breaker.

Long-time overload protection (ANSI 49RMS/51)

The long-time protection protects cables, busbars, and busbar trunkings against overload. It is based on the true RMS current.

It is implemented independently for each phase and the neutral.

This protection is an overcurrent time-dependent protection with thermal memory. It operates as a thermal image using the heating and cooling model of a conductor. After tripping, the protection continues to reproduce the cooling of the conductors. The long-time protection can also be used for transformer or generator protection thanks to the wide range of proposed settings.

Short-time short-circuit protection (ANSI 50TD/51)

The short-time protection protects the installation against short-circuits for phase-to-phase, phase-to-neutral and phase-to-ground short-circuits with total selectivity. It is based on the true RMS current. It includes two characteristics depending on the status of the I^2t setting:

- When I^2t is OFF, a definite time characteristic is selected.
The protection trips with the time delay t_{sd} as soon as the setting current I_{sd} is exceeded.
- When I^2t is ON, an inverse time characteristic is selected.
The protection operates with an inverse time characteristic up to $10 \times I_r$ and with a definite time characteristic above $10 \times I_r$.

Instantaneous short-circuit protection (ANSI 50)

The instantaneous protection protects the installation against phase-to-phase, phase-to-neutral and phase-to-ground short-circuits.

It trips without an additional time delay as soon as the setting current I_i is exceeded. Standard max breaking time: 50 ms for applications requiring selectivity. Full selectivity can be ensured with any ComPacT NSX circuit breaker installed downstream of a MasterPacT.

Ground fault protection (ANSI 50N-TD/51N)

The ground fault protection can be achieved in two ways:

- By performing the summation of the three phases and neutral currents.

The protection includes two characteristics depending on the status of the I^2t setting:

- When I^2t is OFF, a definite time characteristic is selected.
The protection trips with the time delay t_g as soon as the setting current I_g is exceeded.
- When I^2t is ON, an inverse time characteristic is selected.
The protection operates with an inverse time characteristic up to I_n and with a definite time characteristic above I_n .

Protections

Protection functions

B

Neutral overload protection

For a four-pole circuit breaker, the neutral protection may be set from the MicroLogic control unit to one of the following three options:

- Neutral unprotected (4P 3d),
- Neutral protection at $0.5 I_r$ (4P 3d + N/2),
- Neutral protection at I_r (4P 4d). Neutral protection greater than I_r , but lower than I_n , limited at $1.6 I_r$ phase.

For a three-pole circuit breaker the protection of the neutral requires an additional external neutral CT (ENCT). A long-time overcurrent characteristic is dedicated to the neutral protection.

Supervision of tripping voltage releases (ANSI 74)

The MicroLogic Active control unit continuously checks the electrical continuity of the circuit breaker tripping voltage release (MITOP). It generates an alarm in case of failure.

Lock-out function (ANSI 86)

Any operation of the above protection trips and locks the circuit breaker in the open position until it is reset either manually or electrically (see page C-22).

Fault trip indication and inter-trip (ANSI 94)

Any operation of the above protection activates SDE auxiliary contacts for signalling or inter-trip to another device. SDE contact(s) stay closed until the circuit breaker is reset either manually or electrically (see page C-9 and C-22).

Trip history

All trip events (except the most recent) are recorded with the relevant information for their analysis in the trip history. Each record includes:

- The type of protection that causes the trips: long time overload, short time short-circuit, instantaneous short-circuit, ground fault, or ground leakage,
- The date and time of the fault,

The last 30 trip events can be retrieved by means of a PC running EcoStruxure Power Commission or through Bluetooth^[1]. These last trips are also accessible from the embedded display.

In addition, MicroLogic Active also logs:

- The last electrical values measured before the fault (voltages, currents, frequency, unbalance current and voltage),
- The tripping currents during the fault just before MasterPacT MTZ tripping (phase, neutral and ground currents),
- The protection settings.

The last trip may be retrieved through the NFC powerless wireless communication while the circuit breaker is opened and the MicroLogic Active is not energized.

Advanced protections

Other advanced protection features are available on MicroLogic Active: under/overvoltage protections, ground fault alarm and Energy Reduction Maintenance Settings (see ERMS on page B-15). They improve the monitoring and operation of electrical networks. See information on ERMS on page B-15 and I/O voltage protections on page B-27.

Advanced protections are available for the MicroLogic Active E control unit. These protections require the MicroLogic Active E control unit to have an external 24 V DC power supply.

[1] Available soon.

Protections

Protection functions

Protection settings and checking

The protections can be set by means of the embedded HMI, a smartphone running EcoStruxure Power Device via USB, with a PC running EcoStruxure Power Commission, and additionally via Ethernet and Modbus SL communication. EcoStruxure Power Commission allows to:

- Activate, set and check the protection settings;
- Retrieve and display all the information processed by the MicroLogic Active: measurements, alarms and diagnostics ^[1];
- Generate and store reports.

Setting change traceability

Any setting change is recorded in a dedicated protection history including:

- The date and the time of the last setting change;
- The previous settings and the new settings.

The settings corresponding to the active trip curve and the date of the last setting change can be retrieved through NFC powerless wireless communication while the circuit breaker is open and the MicroLogic Active is not energized.

Setting change locking

The general configuration menu of MicroLogic Active embedded display makes it possible to:

- Enable or disable the protection setting change from the embedded HMI;
- Enable or disable the protection setting change by external means of access:
 - A smartphone via USB,
 - A PC running EcoStruxure Power Commission,
 - Ethernet and Modbus SL communication.

In addition, the setting change from external access is password-protected.

Zone-Selective Interlocking (ZSI)

ZSI is a system designed to reduce the stress on electrical distribution equipment during short-circuit or ground fault conditions. It works with a previously coordinated protection by reducing the fault tripping time while maintaining the selectivity. Each version of the MicroLogic Active control unit includes the ZSI function.

The ZSI function is associated with short-time short-circuit protection and ground fault protection. A single ZSI input is provided for ground fault and short-time short-circuit protections.

[1] Available soon.

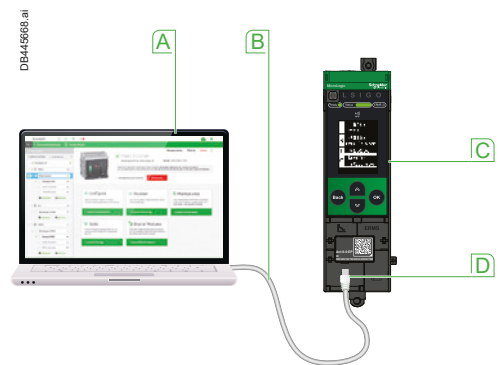
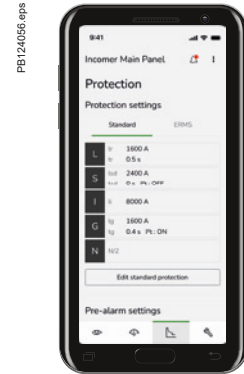

- A** PC running EcoStruxure Power Commission
- B** USB cable
- C** MicroLogic Active control unit
- D** USB connector on the front face

Protections

Protection functions

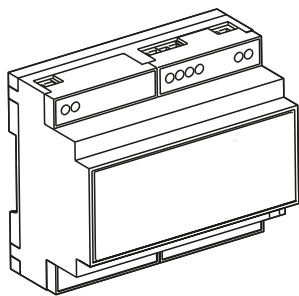
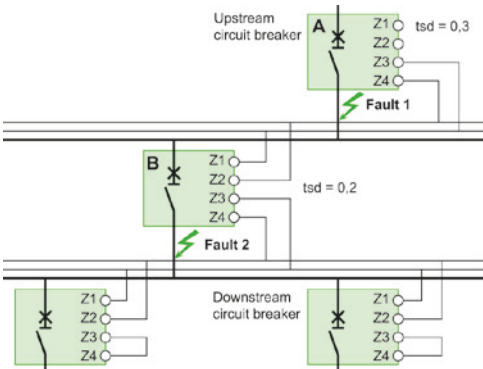

Restraint Interface Module - RIM

PB124059.eps

DB418003R.eps

DB445620.ai

The control unit detecting a fault sends a signal upstream and checks for a signal arriving from downstream. If there is a signal from downstream, the circuit breaker remains closed for the full duration of its tripping delay. If there is no signal from downstream, the circuit breaker trips with no intentional delay, regardless of the tripping-delay setting.

Zone-selective interlocking can be implemented between any types of MasterPac MTZ. When ZSI connects circuit breakers other than MasterPac MTZ, it is necessary to use a Restraint Interface Module (RIM).

Fault 1

Only circuit breaker A detects the fault. Because it receives no restraint signal from downstream, it trips with no intentional delay, regardless of its tripping delay set to 0.3.

Fault 2

Circuit breakers A and B detect the fault. Circuit breaker A receives a restraint signal from B and remains closed for the full duration of its tripping delay set to 0.3.

Circuit breaker B does not receive a restraint signal from downstream and opens immediately, despite of its tripping delay set to 0.2.

Limits to device interconnection:

- A maximum of 15 upstream devices may be connected to the ZSI input (Z1-Z2).
- A maximum of 15 downstream devices may be connected to the ZSI input (Z3-Z4). If additional units are needed, a Restraint Interface Module (RIM) is required.

Restraint Interface Module - RIM (ANSI 78)

The Restraint Interface Module (RIM) serves three purposes in a ZSI system with MasterPac MTZ equipped with MicroLogic Active:

- It boosts the voltage level of the restraint signal;
- It converts the restraint signal to be compatible with other types of Schneider Electric circuit breaker (MasterPac NT/NW, ComPacT) in addition to Square D circuit breakers;
- When combining devices between upstream/downstream (MasterPac MTZ MicroLogic X, MasterPac MTZ MicroLogic Active, MasterPac NT/NW, ComPacT or if there are two MasterPac MTZ MicroLogic Active) it provides double insulation to meet the requirements of IEC standards.

Within a ZSI system, the voltage level of the restraint signal must be maintained at a certain level in order to activate the time delay of electronic trip devices.

If the restraint signal is too weak to activate the time delay feature, all devices that detect the fault will trip with no intentional delay.

The voltage level of the restraint signal can be ineffective due to:

- Restraint wire length exceeding 300 m;
- One device sending a restraint signal to too many devices;
- Differing signal levels between different electronic trip systems.

If the restraint wire length exceeds 300 m, the voltage drop along the control wire will weaken the restraint signal until it can no longer activate the time delay on the upstream device. If wire length exceeds 300 m, a RIM module must be placed in the circuit to boost the voltage level of the restraint signal.

In addition, if the number of upstream circuit breakers exceeds 15, then a RIM is required.

For further details on allowable RIM combinations, please refer to the instruction sheet of the ZSI interface module.

The RIM module is operational for electrical systems with a rated operational voltage [Ue] up to =690 V AC 50/60 Hz only.

Characteristics

- DC power supply: 24 V DC +25 % -20 %, 6 mA.
- Maximum operating temperature surrounding the module when installed inside a switchboard: -35 °C to 75 °C.
- Standards compliance: IEC 60950-1, CISPR 22, CISPR 24, UL 489, UL 489SE.
- CE-marked according to LVD (Low Voltage Directive) / IEC 60950-1.

Connection and Installation

- Terminal strips, jumpers and 35 mm DIN mounting rail (IEC/EN 60715).
- Twisted wire with a braided shield, 300 V AC, 14 AWG - 2.5 mm² / 22 AWG - 0.4 mm².

ERMS - Energy Reduction Maintenance Settings



Under specific circumstances, qualified professionals may need to access and work near energized equipment to perform testing, troubleshooting, and diagnostics. They are thereby subject to the risk of internal arc fault. Current research shows that up to 80% of reported electrical injuries are caused by an electrical arc. In this context, the safety of personnel working on electrical power distribution systems has received increasing attention from a number of regulatory organizations in recent years ^[1].

MasterPact MTZ Active circuit breakers with the “Energy Reduction Maintenance Settings” provide an answer to this issue. The ERMS function, when engaged, allows the MicroLogic Active control unit to operate faster. Should an internal arc fault occur downstream to MasterPact MTZ, the reduced fault clearing time allows a decrease in the amount of energy generated by the electrical arc, and may limit the risk of injury.



Description

The ERMS function is used to reduce the LSIG protection settings in order to trip faster when an internal arc fault occurs. It is acknowledged as one of the recognized solutions to improve the protection of workers against internal arc-fault caused by faulty electrical equipment, abnormal environmental conditions, lack of maintenance, ingress of mice. It complies with the recommendations issued by the regulatory organisations ^[1] dealing with this concern.

As soon as the ERMS button is pressed in the front face of the MicroLogic Active control unit, the ERMS function is engaged. ERMS LSIG settings can be customized on site with EcoStruxure Power Commission software running on a PC. Customization of ERMS settings with EcoStruxure Power Commission software or a smartphone is password-protected ^[2].

As soon as ERMS is engaged, the ERMS LSIG customized settings are automatically applied.

ERMS can also be engaged/ disengaged through an external lockable switch with I/O of the BCIM module.

When ERMS is engaged, the corresponding information is available as follows:

- On the MicroLogic Active front face with the ERMS blue LED
- On the MicroLogic Active embedded display with the blue backlight
- On an external light with BCIM
- On a PC with EcoStruxure Power Commission software
- Through the customer communications network (Ethernet or Modbus SL)

Benefits

The ERMS function complies with the regulations concerning the protection of personnel against the effects of internal arc fault, when under specified condition it becomes necessary to work close to, or in the vicinity of, energized electrical equipment.

ERMS engaged status is visible at a distance thanks to the MicroLogic Active HMI blue backlight. ERMS can be engaged/disengaged with your personal smartphone ^[3].

- [1] NEC Section 240.87 – Acceptable Methods for Arc Energy Reduction
- NFPA 70E: National Fire Protection Association. Standard for Electrical Safety in the Workplace where there are recognized hazardous situations when working on energized electrical equipment.
- IEEE 1584: Guide for Performing Arc-Flash Hazard Calculations provides guidelines for conducting a formal arc flash study
- EN 50 110-1: Operation of electrical installations - General requirements

[2] Available soon.

[3] Available soon with the bluetooth.

[4] ERMS LSIG factory settings.

ERMS settings	Factory settings ^[4]
Ir ERMS	0.4 x In
tr ERMS	0.5
Isd ERMS	1.5 x Ir
tsd ERMS	0
li ERMS	2 x In
Fast trip mode is activated with ERMS for instantaneous protection	
Ig ERMS	0.2 x In
tg ERMS	0



DB-432840.ai

Protections

Tripping curves

MicroLogic Active 2.0

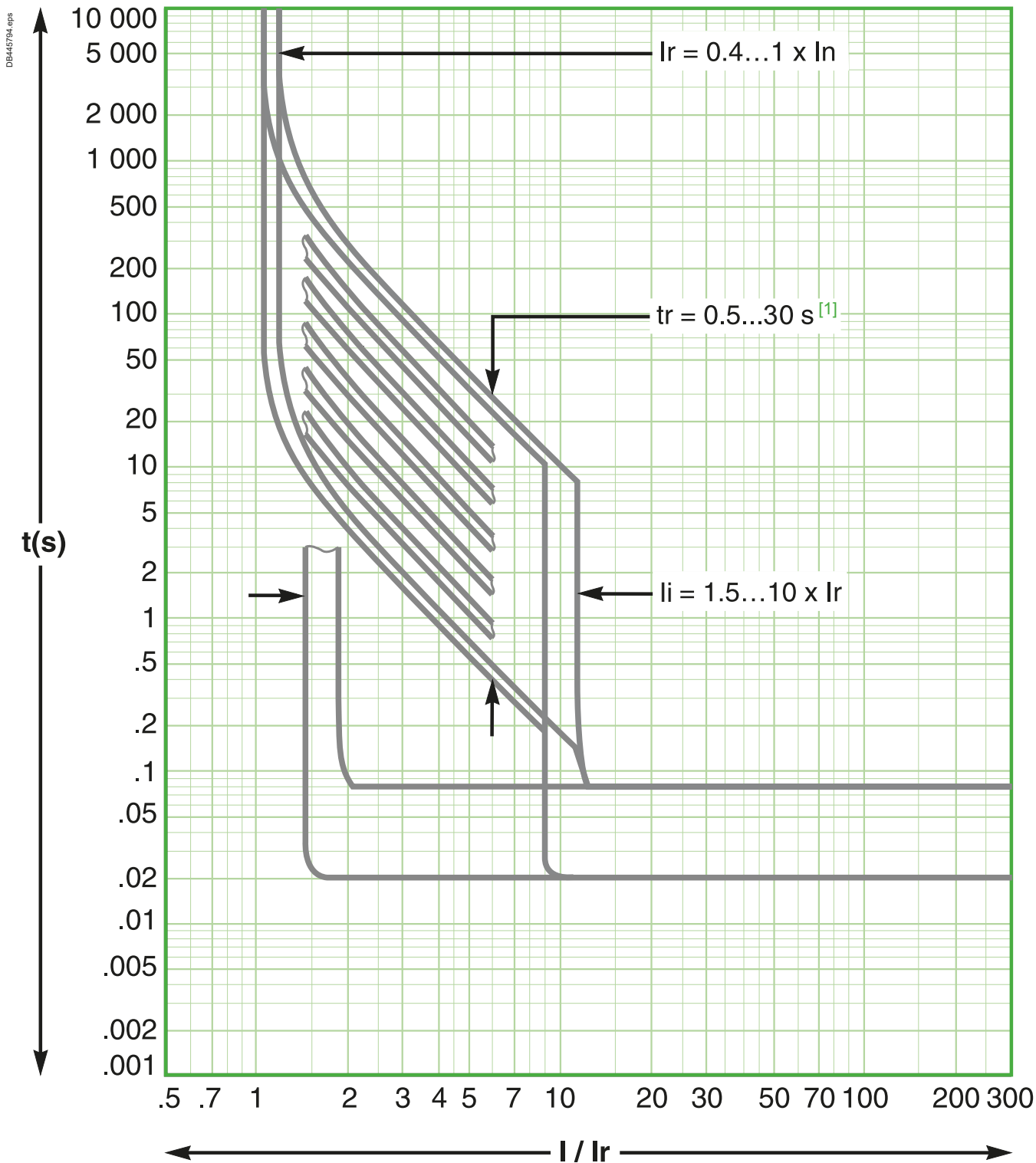

[1] $t_r = 30 \text{ s}$ is only for MT22 and MT23.

Protections

Tripping curves

B

MicroLogic Active 5.0 - 6.0

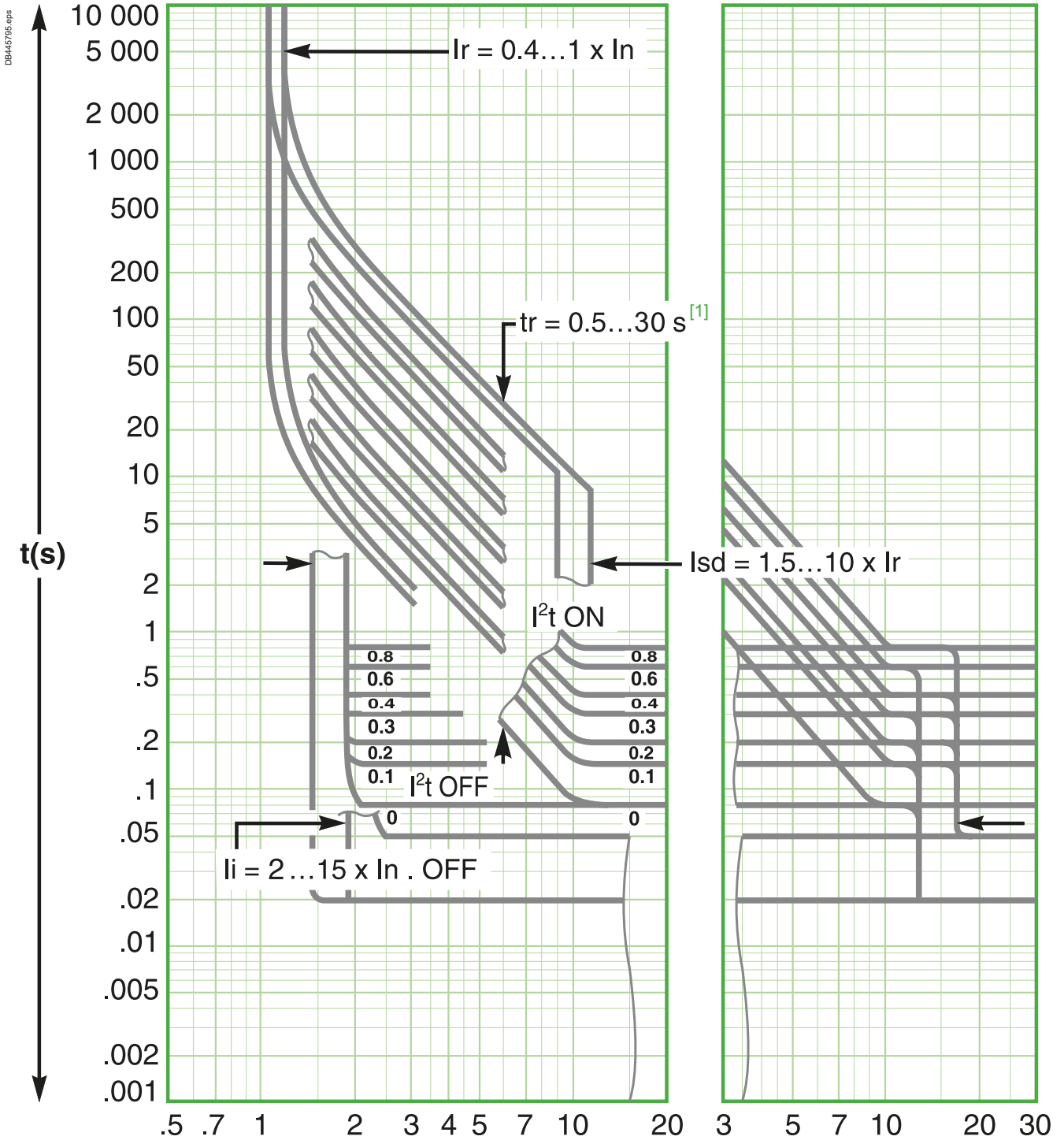

[1] $t_r = 30s$ is only for MTZ2 and MTZ3.

Protections

Tripping curves

Ground fault protection (MicroLogic Active 6.0)

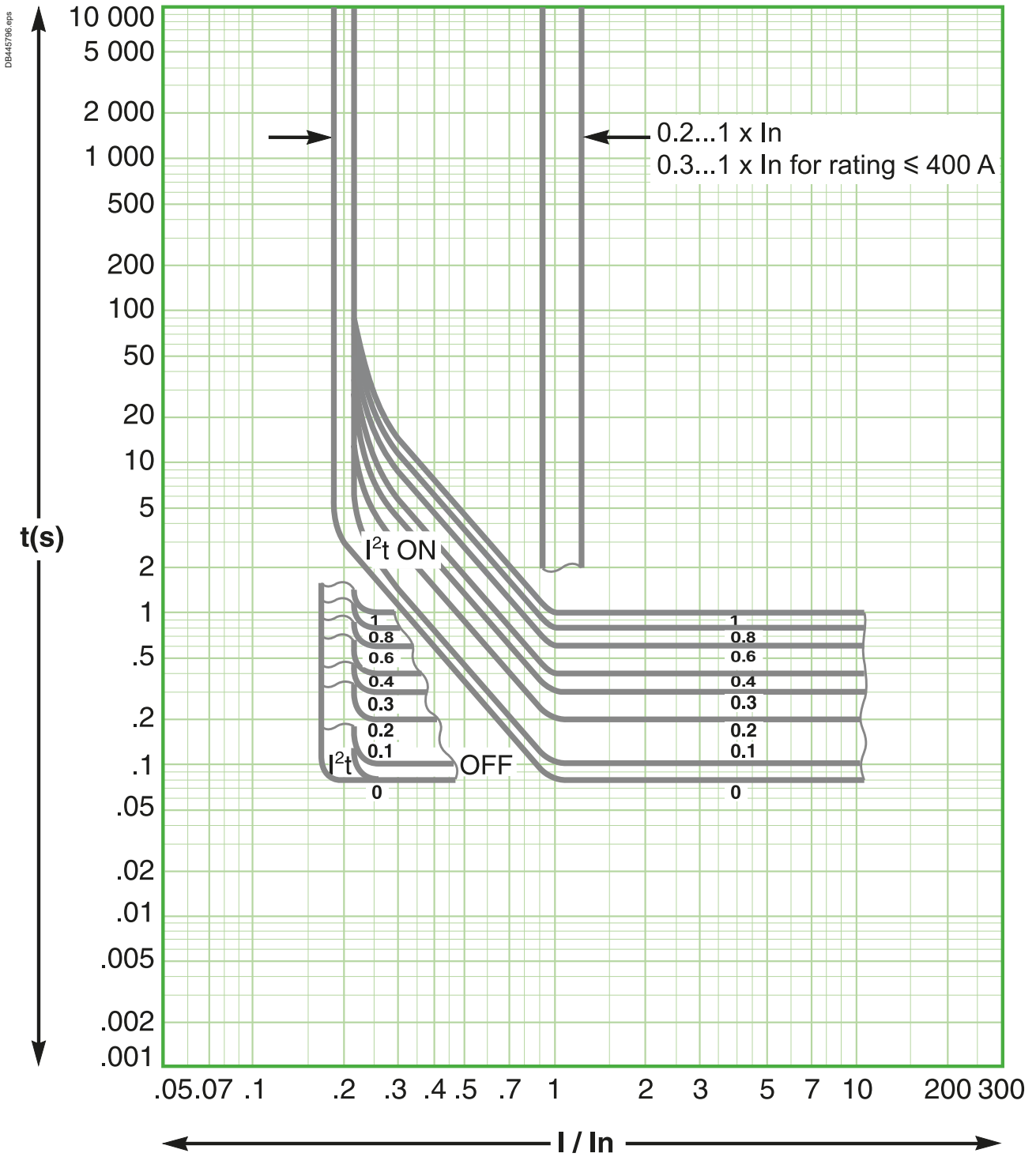

B

Select a MicroLogic Active Control Unit

Protections

Limitation curves



Voltage 380/415/440 V AC

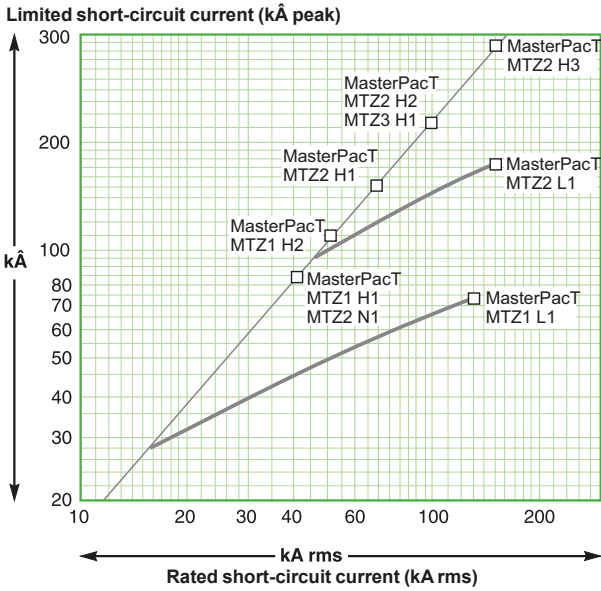

Voltage 660/690 V AC

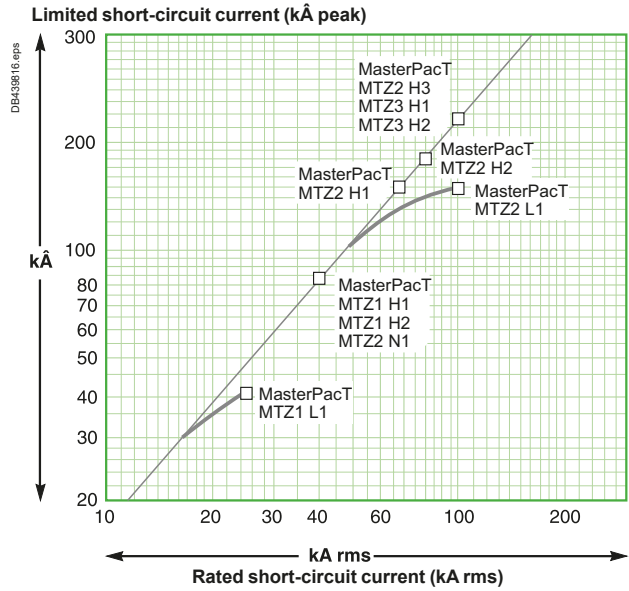

Voltage 380/415/440 V AC

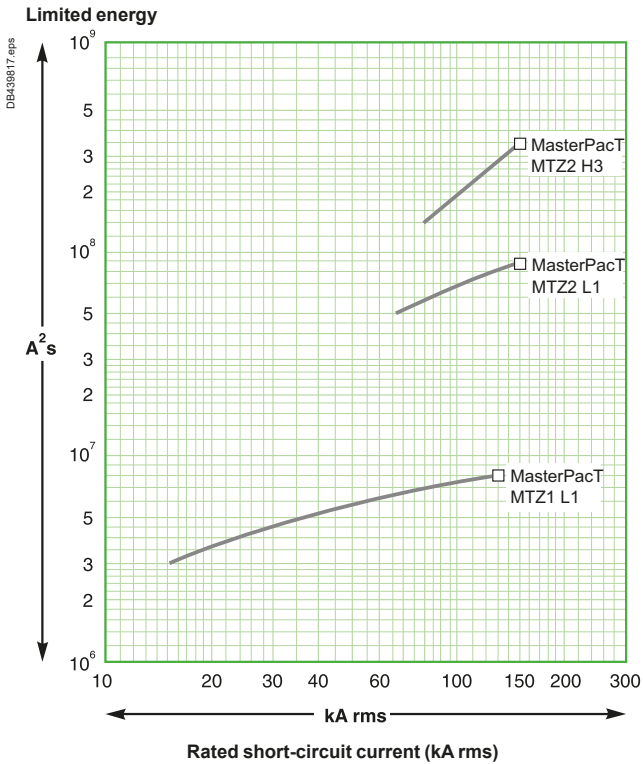

Voltage 660/690 V AC

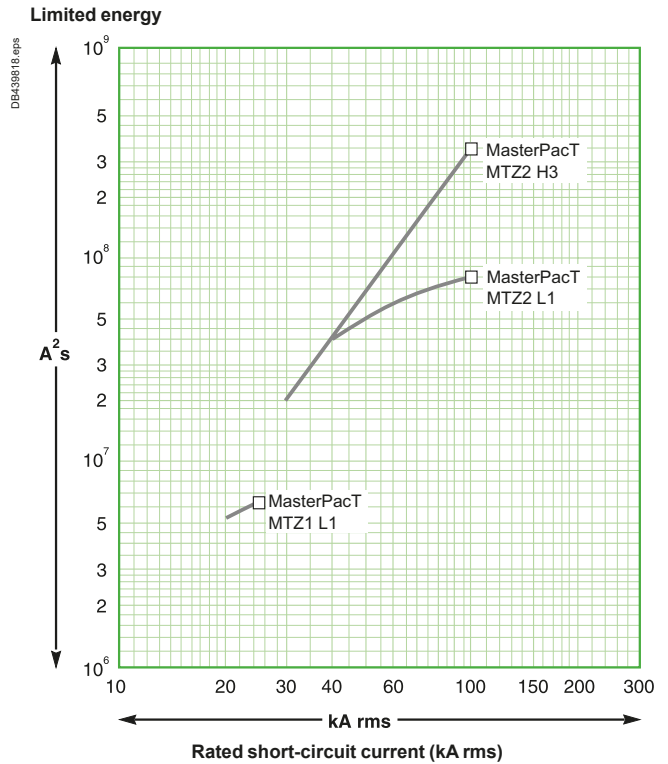

B

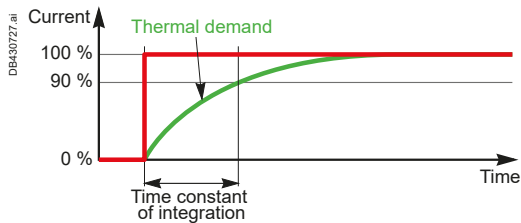
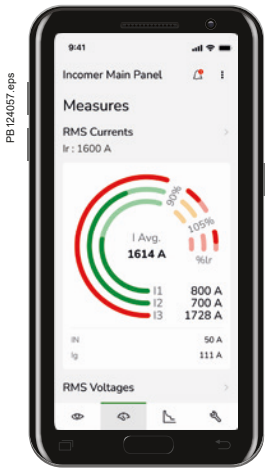

Thermal demand

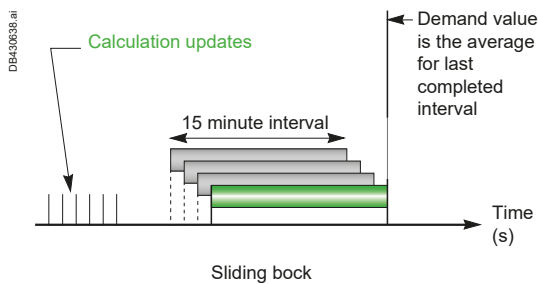

Demand calculated with a sliding block interval

Measures and electrical parameters calculated by the MicroLogic Active control unit

Based on the measurement of line currents, neutral current, phase-to-phase voltages and phase-to-neutral voltages, the MicroLogic Active control unit calculates and displays all the parameters required to monitor any AC electrical power system, including power quality, power management and energy efficiency:

- RMS values of currents and voltages,
- Active, reactive and apparent powers,
- Active, reactive and apparent energies,
- Power factor,
- Frequency,
- Phase sequence,
- Voltage unbalances, Current unbalances,
- Current demands,
- Total active, reactive and apparent power demands.

The current demand is calculated using the thermal method. The time constant of integration is adjustable between 1 and 60 minutes, in steps of 1 minute.

The power demand is calculated by arithmetically integrating power RMS values during a period of time divided by the length of the period. In MicroLogic Active, the power demand is calculated according to the sliding block method, with a sliding block of calculation adjustable between 1 and 60 minutes, in steps of 1 minute.

Electrical values calculated by MicroLogic Active control units can be displayed on the embedded HMI, a smartphone via USB, a PC running EcoStruxure Power Commission software [1] and on the FDM121/128 display unit. They are refreshed every 2 seconds. The display on the embedded HMI is accessed by means of a contextual menu allowing easy navigation through the electrical values. Alternatively, a Quickview option allows the main basic values to be displayed.

MicroLogic Active control units log and time-stamp minimum and maximum values since the last reset of all relevant measurements (currents, voltages, frequency, active power, reactive power, apparent power, etc.). For the complete list of measurements, min/max values and reset, see the *MicroLogic Active User Guide*.

An optional external 24 V DC power supply is required to process and display measurements, including energy counters, for currents below 20 % of the rated current. The phase-to-neutral voltages are available for 4-pole and 3-pole circuit breakers as well providing the connection of the VN terminal of MicroLogic Active to the neutral. To ensure the accuracy of the active power measurement, the connection of the VN terminal of the MicroLogic Active to the neutral is mandatory. Please refer to the *MicroLogic Active User Guide* for more details concerning the wiring and configuration of MicroLogic Active.

Ammeter Measurement

MicroLogic Active A/AP control units measure the true (rms) value of currents. They provide continuous current measurements and are accurate to within 1,5% (including sensors). A colorful HMI displays the most heavily loaded phase (max) or displays the I1, I2, I3, IN, Ig and stored current (maximeter). The optional external power supply makes it possible to display currents < 20% In

Energy and Power Measurement

In addition to the ammeter measurements of MicroLogic Active A/AP

MicroLogic Active E/EP control units measure and display:

- Current demand,
- Voltages: phase to phase, phase to neutral, average and unbalanced,
- Instantaneous power: P, Q, S,
- Power factor: PF,
- Power demand: P demand,
- Energy: Ep, Eq, Es.

Accuracy of active energy Ep is 2 % (including the sensors). The range of measurement is the same as the MicroLogic Active A, depending of an external power supply module (24 V DC).

[1] Available soon.

Electrical power supply availability and reliability are the main critical issues affecting profitability and competitiveness. Outage management focuses on preventing, detecting, locating and clearing faults. Operation and maintenance are mandatory to keep performance of electrical installations at the highest level and to ensure that system users are prepared to manage any crisis that may arise.

The MicroLogic Active control units perform a high level of diagnostics on MasterPacT MTZ circuit breakers in real time. They generate and store appropriate alarms and messages to help users with maintenance and power restoration.

This function complies with the following end-user values:

- Prevent power shutdown to optimize uptime
- Restart quickly after a trip to reduce downtime
- Repair to recover performance of the circuit breaker.
- Generate maintenance reports to record status of the equipment.

Prevent power shutdown

Prevention of unscheduled power shutdown requires:

- Carrying out a preventive maintenance plan.
- Being informed of the circuit breaker health.
- Anticipating component/device replacement

Carry out a preventive maintenance plan

- As standard, MicroLogicActive periodically reminds the end-users to schedule either an intermediate End-User maintenance program or a manufacturer maintenance program.
- Intermediate End-User maintenance is recommended to be performed by a service provider. The frequency of this program is every 2 years. The plan includes: automatic protection curve testing, operational servicing and sub-assembly test.
- Manufacturer maintenance can be performed by a Schneider Electric Field Service representative on request.

The frequency of this program is by default every 5 years (within normal operating and environmental conditions, and for user applications of low criticality). The scope is in addition to the standard program: complete evaluation of the device performance and data diagnostics (Measure of the insulation resistance, opening/closing time, etc.) and diagnostics.

MicroLogic Active and EcoStruxure Power Device App display the last and next maintenance program to be performed. Details of the maintenance program are described in the *MasterPacT MTZ Maintenance Guide* (DOCA0099EN). The manufacturer maintenance program can be performed by a Schneider Electric Field Service representative on request.

Be alerted of the health of the circuit breaker

As standard, the MicroLogic Active control unit is equipped with a LED status bar to provide information on the overall health of the circuit breaker. A pop-up message will appear on the screen as a reminder of when to perform maintenance.

The LED status bar can have three states:

- Green color: the circuit breaker is in good working order,
- Orange color: non-urgent intervention required (contact wear above 60 %, remaining service life of MicroLogic below alarm threshold, manufacturer maintenance due within three months, etc.),
- Red color: alarm message that requires immediate intervention (contact wear above 100 %, MicroLogic having reached the maximum service life, failure of the tripping chain, malfunction of the control unit, etc.).

The associated alarms are displayed on the embedded HMI and a QR code is displayed within the HMI to give instructions after trip. There is also a trip context area to provide details on trip conditions. The alarms requiring non-urgent intervention are displayed with an orange color, the alarms requiring immediate intervention and trips with a red color.

The information is also accessible from a smartphone via USB or NFC wireless communication, a PC running EcoStruxure Power Commission software.

When the MicroLogic Active control unit is not energized, only the trip alarms with their associated messages remain accessible with a smartphone through NFC.

[1] Available soon.

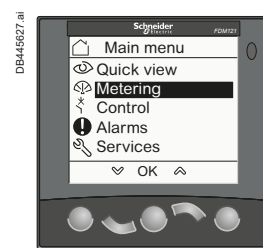
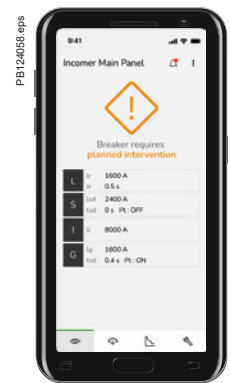













FDM121



FDM128 [1]

B

The various possibilities for displaying alarms and messages concerning the management of maintenance and the health of the circuit breaker are summarized in the following table:

MicroLogic Active control unit energized							MicroLogic Active control unit not energized
	Display on EHMI Alarm 	Display on EHMI Alarm	Display on smartphone with USB	EcoStruxure Power Commission software USB connection	Display on FDM121	IFE/EIFE web pages	Display trip alarm on smartphone with NFC
Alarms	Orange color						
Alarms		Red color					

Anticipate component/device replacement

As standard, MicroLogic Active monitors most of the active mechanical components (circuit breaker, chassis and MCH gear motor to charge the spring mechanism) and the MicroLogic control unit itself. In addition, MicroLogic Active calculates the contact wear ratio based on the number of operations and tripping current. MicroLogic Active and EcoStruxure Power Device app display the remaining service life of the circuit breaker and the MicroLogic Active control unit. Alarms help the users to anticipate the replacement of these circuit breaker components.

Restart quickly after a trip

As standard, the trip LEDs and LED status bar on the front of the MicroLogicActive control unit quickly identify the tripping cause (short-circuit, ground fault or overload). MicroLogic Active and EcoStruxure Power Device app display all the relevant information related to the trip (tripping cause, date and time, tripping current, settings of the protection).

Repair

Repairing circuit breaker components requires:

- The right level of assistance
- The precise identification of the circuit breaker and its associated spare parts

Assistance

As standard, MicroLogic Active and EcoStruxure Power Device app display the name and phone number of the Service Provider who performed the last maintenance.

Identification

By scanning the QR code displayed on the front face of the MicroLogic Active control unit, users will have access to:

- Serial number of the MicroLogic Active control unit
- Bill Of Material (as built) of the circuit breaker and the optional accessories installed on the circuit breaker
- Product code in order to be able to reorder the identical circuit breaker.
- References of the spare parts
- Link to download user guides and Instruction sheet.

In addition, to maintain the performance of the circuit breaker, Schneider Electric proposes the three following services: warranty on components, maintenance on demand or advanced service plans. For more information, please refer to Services (chapter H).

Generate maintenance reports

As standard, MicroLogic Active control unit provides all the relevant information (product ID, protection settings, configuration parameters, logs, trip context) in order for EcoStruxure Power Commission software to generate maintenance reports.

Select a MicroLogic Active Control Unit

Maintenance and diagnostics

B



Prevent power shutdown with conditional checks

Monitored functions & Logs Circuit breaker operation

Tripping function

- Tripping chain continuity (Ready LED)
- Trip counter by Mitop (SDE)
- Time-stamped tripping log
- Trip counter for I_r , I_{sd} , I_i , I_g



Monitored functions & Logs Fault detection on MicroLogic Active

Sensors Disconnection

- Internal current sensor disconnected
- External current sensor disconnected

MicroLogic Active internal failure

- Internal overtemperature
- Protection out of service
- Unable to read sensor plug
- Internal battery
- Tripping voltage release (Mitop) not detected

External Communication failure

- Invalid NFC communication
- Invalid Zigbee communication
- Ethernet Error communication (IFE)

Preventive maintenance

Maintenance alarm

Closing function

- XF operations is above alarm threshold
- XF has reached the max number of operations
- MCH charging operations is above alarm threshold
- MCH has reached the max number of operations

Opening function

- MX1 operations is above alarm threshold
- MX1 has reached the max number of operations
- MX2 operations is above alarm threshold
- MX2 has reached the max number of operations
- MN operations is above alarm threshold
- MN has reached the max number of operations

Maintenance program reminder

- Schedule intermediate maintenance within one month
- Schedule manufacturer maintenance within three months

Circuit breaker

- Remaining service life of circuit breaker is below alarm threshold
- Circuit breaker has reached the max number of operations
- Contact wear >60%
Check contacts
- Contact wear >95%
Plan replacement
- Contact wear >100%
Replace circuit breaker

MicroLogic Active

- Remaining service life of the MicroLogic Active is below alarm threshold
- MicroLogic Active has reached the max service life

From all the functions processed by MicroLogic Active, a list of predefined events has been selected for notifying the user of alarms, and traceability. All these events are time-stamped and logged in non-volatile memory. For ease of use, these events have been classified in seven histories: trip, protection, diagnostic, metering, configuration, operation, and communication.

Definition and categories of events

In addition to their main action of tripping, measuring, and counting, MicroLogic Active functions produce events available for alarm notification and history logging.

Event characteristics

All events are time-stamped and logged in non-volatile memory.

Event history

All events are logged in one of the histories of the MicroLogic Active control unit:

- Trip: Long-time trip, short-time trip, trip on internal failure, etc.
- Protection: Setting change, $I > 90\% I_r$ Long time, etc.
- Diagnostic: Low battery, etc.
- Metering: Reset min/max, reset energy counters, etc.
- Configuration: Protection settings modified, etc.
- Operation: Opening, closing, alarm reset, etc.
- Communication: Bluetooth enabled, etc.

All events are logged regardless of their severity, including low-level events. Each history has a predefined maximum size. When a history is full each new event overwrites the oldest event, and other histories are left unchanged (FIFO).

For the complete list of events, see the *MicroLogic Active User Guide*.

Event notification

- High-severity events generate pop-ups on embedded HMI with a red color.
- Medium-severity events generate pop-ups on embedded HMI with an orange color.
- On the FDM128 display unit they change the related pictogram color to orange ^[1].
- All events can be directed individually to BCIM digital output.
- All events can trigger an email through EIFE or IFE communication interfaces.
- High-severity and medium-severity active events can be read on the embedded HMI, a PC or a smartphone.
- All the events logged in histories can be displayed on a PC with EcoStruxure Power Commission, a smartphone or the FDM121 display unit. They are displayed in chronological order. They can be sorted according to the following properties: date and time, severity, or history.
- Additionally, all the events logged in histories are accessible via Ethernet and Modbus SL through the EIFE, IFE and IFM interfaces.

Event type, latch mode and reset mode

They are two types of events:

- Occurrence / Completion events: these events have a beginning and an end (for example long-time pick-up and dropout).
 - Instantaneous events: these events have no duration (for example reception of an opening order, breaker tripping or settings changes).
An event may be latched or unlatched:
 - A latched event does not reset automatically. It remains in the held position after its cause has disappeared until it is reset by the user.
 - An unlatched event is active while its cause is present and returns to inactive as soon as its cause disappears or is resolved.
- For latched events a reset action can be performed from:
- The test/reset button on the front face of the MicroLogic Active.
 - From a PC
 - From a smartphone
 - Via Ethernet and Modbus SL through the EIFE, IFE and IFM interfaces

A command from the test/reset button, a PC, a Smartphone, Ethernet or Modbus SL resets all the held events managed by MicroLogic Active.

[1] Available soon.

Event history	Maximum number of events
Trip	30
Protection	50
Diagnostic	200
Operation	160

Select a MicroLogic Active Control Unit

Event management

B

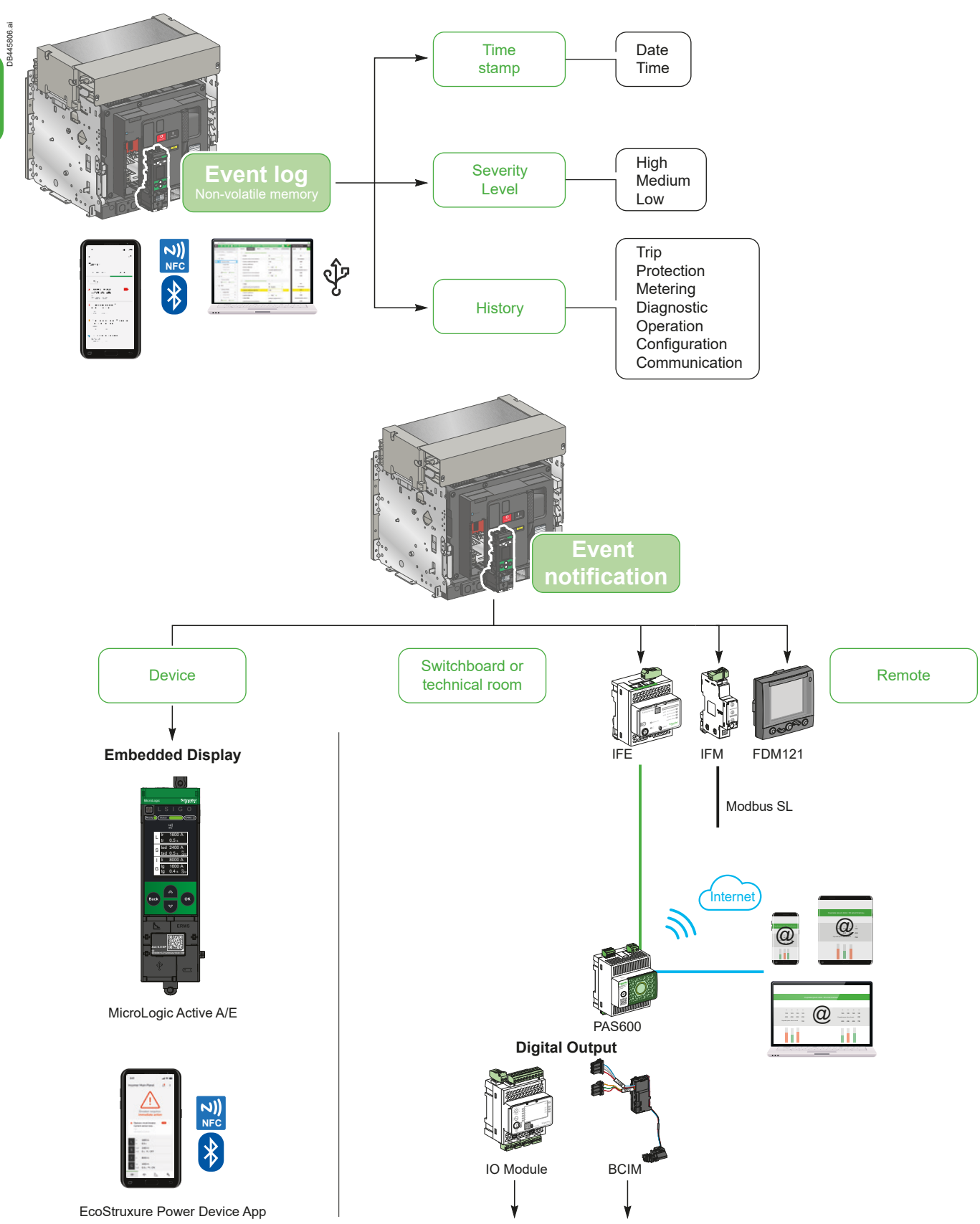

MicroLogic Active is a self-powered protection control unit. The basic functions of protection (LSIG) do not require any power supply. Below 20 % of the rated current, a 24 V DC supply is required for its proper operation and all its specified performance characteristics for measurement, diagnosis, display and communication functions.

MicroLogic Active is equipped with a robust internal power supply as well as various alternative external power supplies to respond to any situation.

The MicroLogic Active control unit combines the following sources of supply:

- The internal currents provided by the embedded current transformers,
- An external 24 V DC power supply,
- A PC supply via a USB-C port,
- A portable battery.

When the currents are higher than 20 % of the rated current, the internal current supply ensures the proper operation of the MicroLogic Active control unit.

This includes:

- The accurate performance of the protection functions, i.e. long-time overload protection, short-time short circuit protection, instantaneous short circuit protection, ground fault protection
- All the measures with the level of accuracy specified on [page B-20](#) of this catalog
- The diagnosis
- The HMI (embedded display and key pad)
- The wireless features (Zigbee).

When the currents fall below 20 % of the rated current, the internal current supply is not enough to ensure the proper operation of the MicroLogic Active control unit.

An external 24 V DC power supply is required to ensure the operation of all the functions processed by MicroLogic Active with the specified performance characteristics.

For wireless option, it is recommended to use a 24V external power supply.

The following 24 V DC supplies are recommended:

- The external 24 V DC MicroLogic Active power supply with or without an additional battery module
- The Universal Phaseo ABL8 RPS 24050 (24 V DC, 5 A, 120 W) or ABL8 RPS 24030 (24 V DC, 3 A, 72 W) power supplies.

MicroLogic Active is also equipped with an internal lithium-type battery unit as a power supply specifically for the trip cause LEDs and the internal real-time clock. It allows the user to read and identify the trip cause when the breaker trips. Its condition can be checked by pressing the test button on the front of the MicroLogic Active control unit. An alarm is issued when the voltage of the battery reaches its low level.

When EIFE, IFE or IFM communication modules, FDM121 or FDM128 display unit are installed, an external 24 V DC power supply is mandatory to supply power to these devices.

The XF, MX and MN voltage releases and the electric motor MCH require a power supply separate from the MicroLogic Active power supply.

Select a MicroLogic Active Control Unit

Power supply

B

Recommended selection of alternative power sources in different situations

Situation	Purpose	External 24 V DC power supply	PC power supply	Portable battery
When the circuit breaker is energized, but the current is below 20 % of the rated current	Ensure the performance of protections, measurements, communication, diagnosis, HMI, wireless features	<input checked="" type="radio"/>	<input type="radio"/>	<input type="radio"/>
When the circuit breaker is opened or not energized	Retrieve information through MicroLogic HMI	<input checked="" type="radio"/>	<input checked="" type="radio"/>	<input checked="" type="radio"/>
	Retrieve information through USB	<input checked="" type="radio"/>	<input checked="" type="radio"/>	<input checked="" type="radio"/>
During setting, commissioning, testing and maintenance	Perform all relevant actions	<input checked="" type="radio"/>	<input checked="" type="radio"/>	<input checked="" type="radio"/>
When IFE/EIFE, IFM, FDM121 or FDM128 are installed	Power these devices	<input checked="" type="radio"/>	<input type="radio"/>	<input type="radio"/>

Note: Please refer to the chapter on accessories for more details concerning an external 24 V DC power supply or a portable battery

	MicroLogic Active	EIFE	IFE	FDM121 only
Current consumption (mA) 24 V DC	80	100	150	40

Voltage measurement inputs

Voltage measurement inputs are required for power measurements. As standard, the control unit is supplied by internal voltage measurement inputs placed downstream of the pole for voltages between 220 and 690 V AC. On request, it is possible to replace the internal voltage measurement inputs by an external voltage input (PTE option) which enables the control unit to draw power directly from the distribution system upstream of the circuit breaker. A 3 m cable with ferrite comes with this PTE option.

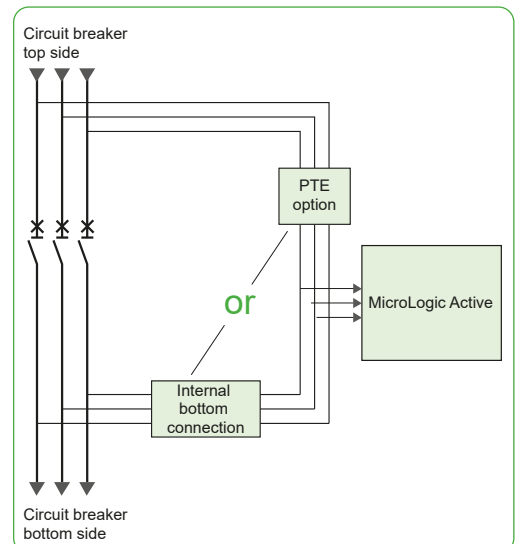

Note: PTE option connected to the top side of the circuit breaker. It can also be connected to the bottom side.

Customize your Circuit Breaker with Accessories

Overview of accessories.....	C-2
Design and installation simplification	
Connection.....	C-4
Operation efficiency	
Signalling.....	C-8
Controlling.....	C-13
Protection of people and property	
Locking and interlocking.....	C-21
Circuit protection.....	C-25
Operational and mechanical protection.....	C-27
Power availability and reliability	
Power supplies.....	C-30



Other chapters

- "Select a Circuit Breaker", page A-1
- "Select a MicroLogic Active Control Unit", page B-1
- "Integrate in Smart Panels - Architecture and Systems", page D-1
- "Integrate in a Switchboard", page E-1
- "Integrate in Special Applications Source-Changeover Systems", page F-1
- "Services", page G-1
- "Order your Circuit Breaker", page H-1

Overview of accessories



Drawout version



Fixed version

C

Design and installation simplification - connection		> On page C-4	
	Applicable for	Fixed	Drawout
Horizontal and vertical rear connection	MTZ 1/2/3	<input checked="" type="radio"/>	<input checked="" type="radio"/>
Front connection	MTZ 1/2/3	<input checked="" type="radio"/>	<input checked="" type="radio"/>
Vertical-connection adapters	MTZ 1	<input checked="" type="radio"/>	<input checked="" type="radio"/>
Cable-lug adapters	MTZ 1	<input checked="" type="radio"/>	<input checked="" type="radio"/>
Spreaders	MTZ 1	<input checked="" type="radio"/>	<input checked="" type="radio"/>
Disconnectable front connection adapter	MTZ 2/3	<input checked="" type="radio"/>	<input type="radio"/>
Interphase barriers	MTZ 1/2/3	<input checked="" type="radio"/>	<input checked="" type="radio"/>
CC - arc chute cover	MTZ 1	<input checked="" type="radio"/>	<input type="radio"/>
Brackets for mounting	MTZ 2/3	<input checked="" type="radio"/>	<input type="radio"/>
Operation efficiency - Signalling		> On page C-8	
OF - ON/OFF indication contacts	MTZ 1/2/3	<input checked="" type="radio"/>	<input checked="" type="radio"/>
SDE - fault-trip indication contact	MTZ 1/2/3	<input checked="" type="radio"/>	<input checked="" type="radio"/>
EF - combined connected/closed contacts	MTZ 2/3	<input type="radio"/>	<input checked="" type="radio"/>
CE, CD, CT - Carriage switches	MTZ 1/2/3	<input type="radio"/>	<input checked="" type="radio"/>
PF - ready-to-close contact	MTZ 1/2/3	<input checked="" type="radio"/>	<input checked="" type="radio"/>
CDM - mechanical operation counter MTZ1/2/3	MTZ 1/2/3	<input checked="" type="radio"/>	<input checked="" type="radio"/>
Operation efficiency - Controlling		> On page C-13	
XF - standard closing voltage release	MTZ 1/2/3	<input checked="" type="radio"/>	<input checked="" type="radio"/>
XF - reinforced closing voltage release	MTZ 1/2/3	<input checked="" type="radio"/>	<input checked="" type="radio"/>
MX - standard opening voltage release	MTZ 1/2/3	<input checked="" type="radio"/>	<input checked="" type="radio"/>
MX - reinforced opening voltage release	MTZ 1/2/3	<input checked="" type="radio"/>	<input checked="" type="radio"/>
MN - standard undervoltage release	MTZ 1/2/3	<input checked="" type="radio"/>	<input checked="" type="radio"/>
MN - reinforced undervoltage release	MTZ 1/2/3	<input checked="" type="radio"/>	<input checked="" type="radio"/>
R - non-adjustable delay unit	MTZ 1/2/3	<input checked="" type="radio"/>	<input checked="" type="radio"/>
Rr - adjustable delay unit	MTZ 1/2/3	<input checked="" type="radio"/>	<input checked="" type="radio"/>
BCIM (ULP isolation module)	MTZ 1/2/3	<input checked="" type="radio"/>	<input checked="" type="radio"/>
MCH - gear motor	MTZ 1/2/3	<input checked="" type="radio"/>	<input checked="" type="radio"/>
RES - electrical reset option	MTZ 1/2/3	<input checked="" type="radio"/>	<input checked="" type="radio"/>
RAR - automatic reset option	MTZ 1/2/3	<input checked="" type="radio"/>	<input checked="" type="radio"/>
Protection of people and property - Locking and Interlocking		> On page C-23	
VBP - ON/OFF pushbutton locking	MTZ 1/2/3	<input checked="" type="radio"/>	<input checked="" type="radio"/>
VSPO-VCPO - OFF position locking	MTZ 1/2/3	<input checked="" type="radio"/>	<input checked="" type="radio"/>
Chassis locking in disconnected position by padlock	MTZ 1/2/3	<input checked="" type="radio"/>	<input checked="" type="radio"/>
VSPD - Chassis locking in disconnected position by keylock	MTZ 1/2/3	<input type="radio"/>	<input checked="" type="radio"/>
Optional connected/disconnected/test position locking	MTZ 1/2/3	<input type="radio"/>	<input checked="" type="radio"/>
VO - Safety shutters (with standard padlocking)	MTZ 1/2/3	<input type="radio"/>	<input checked="" type="radio"/>
VIVC - shutter position indication and locking	MTZ 2/3	<input type="radio"/>	<input checked="" type="radio"/>
IPA - cable-type door interlock	MTZ 1/2/3	<input checked="" type="radio"/>	<input checked="" type="radio"/>
VPEC - door interlock	MTZ 1/2/3	<input type="radio"/>	<input checked="" type="radio"/>
VPOC - racking interlock	MTZ 1/2/3	<input type="radio"/>	<input checked="" type="radio"/>
IBPO - racking interlock between crank and OFF pushbutton	MTZ 2/3	<input type="radio"/>	<input checked="" type="radio"/>
V DC - mismatch protection	MTZ 1/2/3	<input type="radio"/>	<input checked="" type="radio"/>
Protection of people and property - Circuit protection		> On page C-25	
TCE - external sensor for neutral and residual ground fault protection	MTZ 1/2/3	<input type="radio"/>	<input checked="" type="radio"/>
Protection of people and property - Operational protection		> On page C-27	
DAE - automatic spring discharge before breaker removal	MTZ 2/3	<input type="radio"/>	<input checked="" type="radio"/>
KMT - grounding kit	MTZ 2/3	<input checked="" type="radio"/>	<input checked="" type="radio"/>
Protection of people and property - Mechanical protection		> On page C-27	
CB - terminal block shield	MTZ 1/2/3	<input type="radio"/>	<input checked="" type="radio"/>
CDP - escutcheon	MTZ 1/2/3	<input checked="" type="radio"/>	<input checked="" type="radio"/>
OP - blanking plate for escutcheon	MTZ 1/2/3	<input checked="" type="radio"/>	<input checked="" type="radio"/>
CP - transparent cover for escutcheon	MTZ 1/2/3	<input type="radio"/>	<input checked="" type="radio"/>
Power availability and reliability - Power supplies		> On page C-30	
External 24 V DC power supply module (AD/ABL8)	MTZ 1/2/3	<input checked="" type="radio"/>	<input checked="" type="radio"/>
BAT - battery module	MTZ 1/2/3	<input checked="" type="radio"/>	<input checked="" type="radio"/>
Mobile Power Pack by APC	MTZ 1/2/3	<input checked="" type="radio"/>	<input checked="" type="radio"/>
Spare internal battery	MTZ 1/2/3	<input checked="" type="radio"/>	<input checked="" type="radio"/>



Mounting versions

MasterPacT circuit breakers are available in two mounting versions: fixed and drawout. The drawout version is preferred in most of the applications thanks to the following benefits:

- Visible separation of the power contacts via racking out
- Easy and complete access to the device for periodic maintenance
- Possibility of a quick replacement of the device if necessary

MasterPacT MTZ Accessories provide the possibility to further customize the circuit breaker and enhance functionality at all stages of the lifecycle.

- The comprehensive range of accessories addresses the needs of the majority of applications
- Many accessories are common to MasterPacT NT, NW, MTZ1, MTZ2 and MTZ3. In addition, some accessories are also common to MasterPacT and ComPacT ranges. Safety stock can therefore be optimized and less training is required to master the installation of different Schneider Electric circuit breaker ranges. The design of the circuit breaker addresses the need for simplified installation, last-minute changes and future upgrading.

MasterPacT MTZ2/3 drawout version as an example

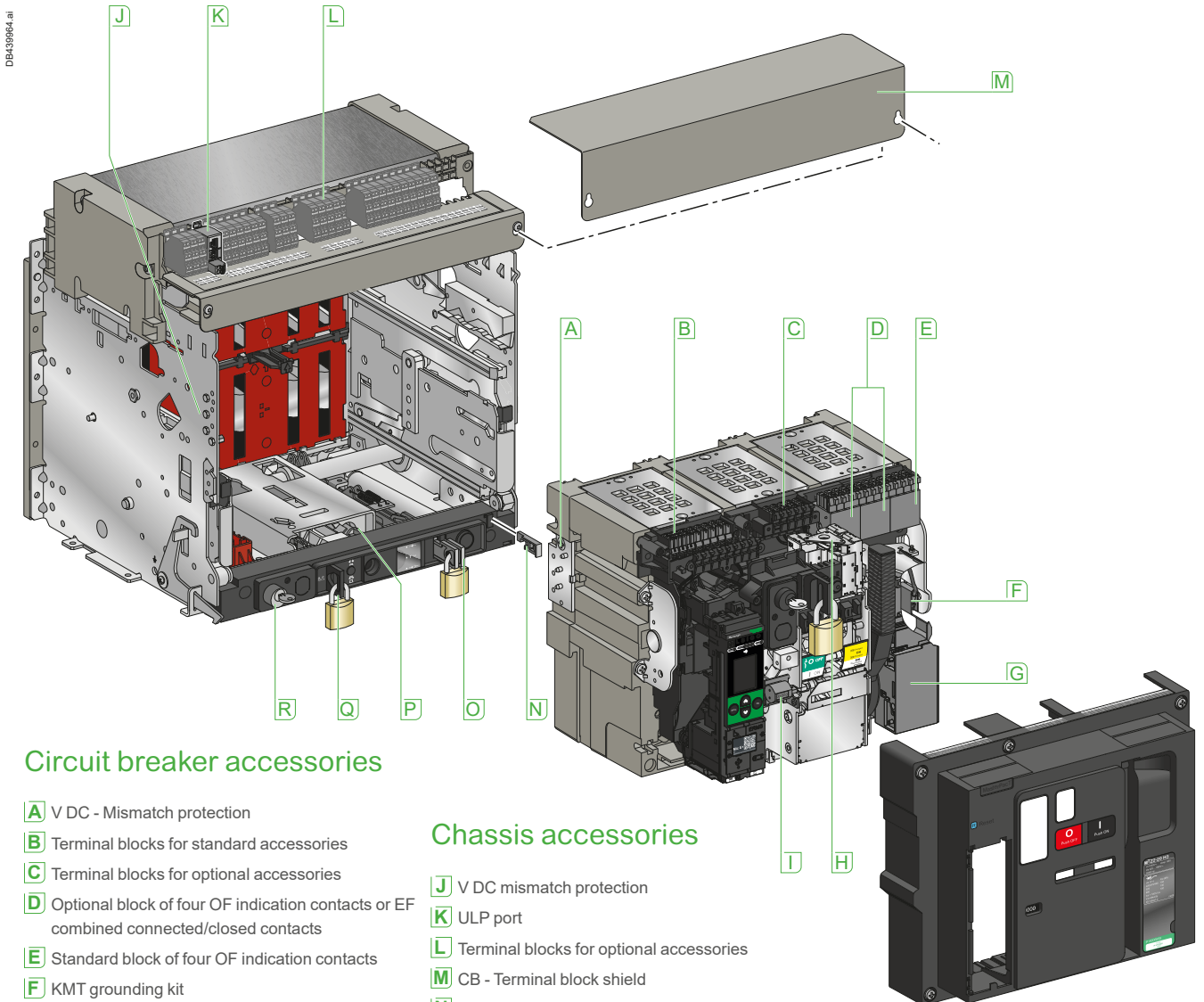

Circuit breaker accessories

- A** V DC - Mismatch protection
- B** Terminal blocks for standard accessories
- C** Terminal blocks for optional accessories
- D** Optional block of four OF indication contacts or EF combined connected/closed contacts
- E** Standard block of four OF indication contacts
- F** KMT grounding kit
- G** MCH gear motor
- H** MX, XF, MN
- I** CDM operation counter

Chassis accessories

- J** V DC mismatch protection
- K** ULP port
- L** Terminal blocks for optional accessories
- M** CB - Terminal block shield
- N** VPOC racking interlock
- O** VIVC Shutter position indication locking
- P** Latch to lock the device in any position
- Q** Chassis locking in disconnected position by padlock
- R** VSPD - Chassis locking in disconnected position by keylock

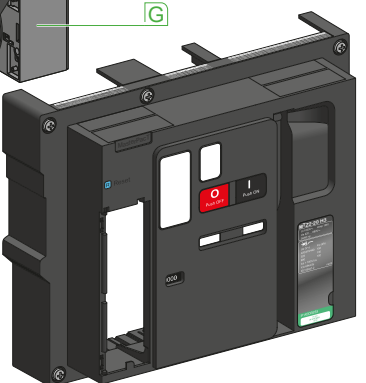

Design and installation simplification

Connection

Simple and adaptable design, and accurate and fast installation are the two priorities when building a switchboard. MasterPacT MTZ provides three types of basic connections and additional accessories to fulfill different connection needs and to simplify installation.

C

MasterPacT MTZ1 fixed version as an example

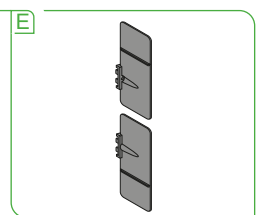
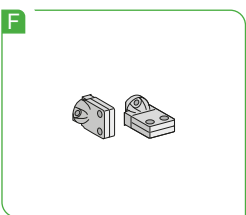
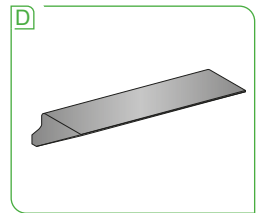
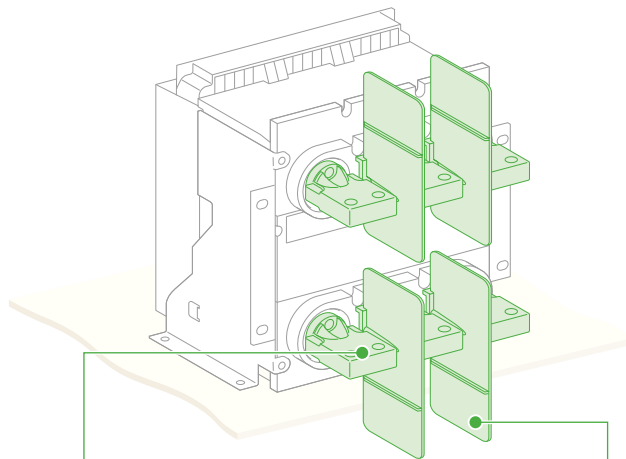
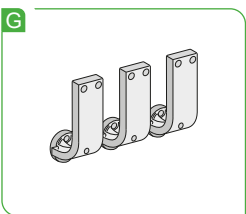
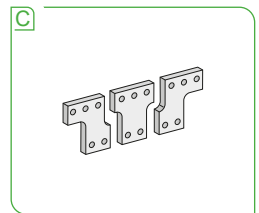
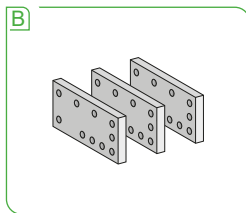
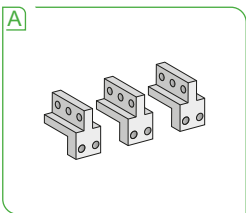

Connection accessories

- A** Vertical connection adapters
- B** Cable-lug adapters
- C** Spreaders

- D** Arc chute screen
- E** Interphase barriers

Connection

- F** Horizontal and vertical rear connection
- G** Front connection

Note: For more information, see Chapter E.

Customize your Circuit Breaker with Accessories

Design and installation simplification

Connection

C

Three types of basic connections are available for MasterPacT MTZ1, MTZ2 and MTZ3 devices:

- Rear vertical connection
- Rear horizontal connection
- Front connection

Top and bottom can have different connection types (mixed connection).

Changing between horizontal and vertical rear connection is possible by simply turning the terminal 90°.

MasterPacT circuit breakers can be connected indifferently with bare-copper, tinned-copper or tinned-aluminum conductors. No special treatment is required.

MasterPacT MTZ2/3 fixed version as an example

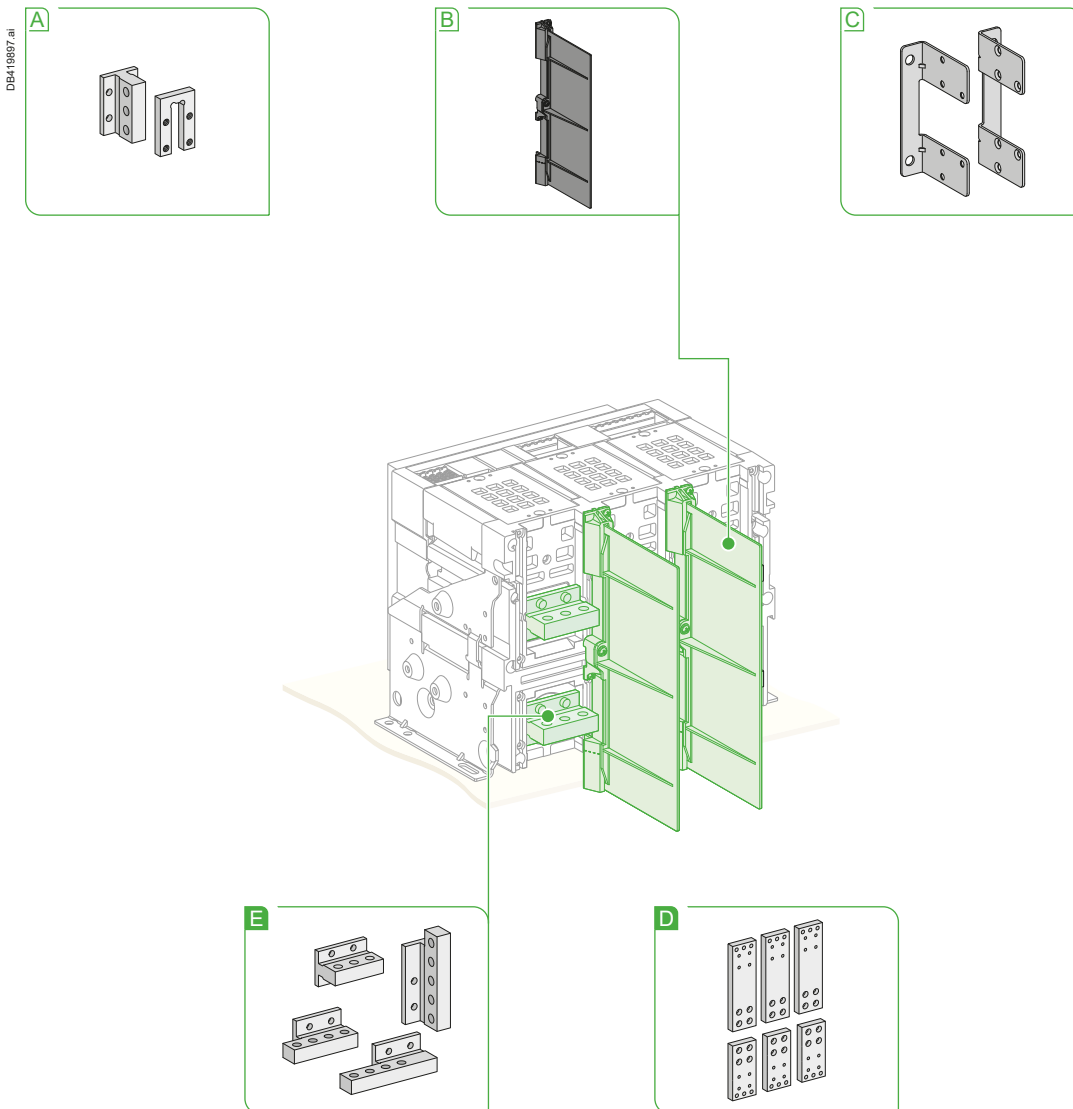

Connection accessories

- A** Disconnectable front connection adapter
- B** Interphase barriers
- C** Mounting brackets

Connection

- D** Front connection
- E** Horizontal and vertical rear connection

Note: For more information, see Chapter E.

Customize your Circuit Breaker with Accessories

Design and installation simplification

Connection

Three types of connections are available

Rear connection

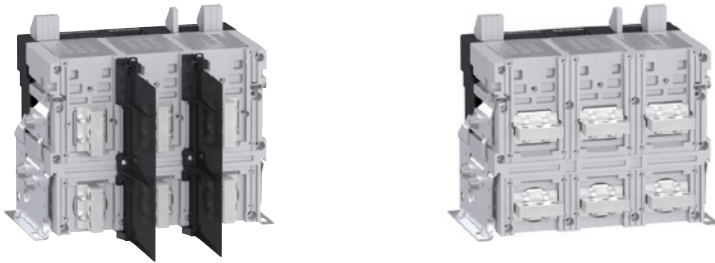

Front connection

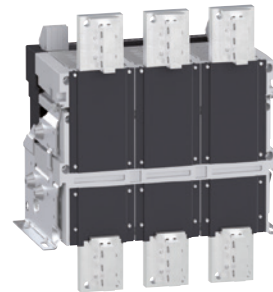

For 6300 A circuit breaker only vertical connection is available.

Front connection is available for fixed and drawout versions up to 3200 A.



Fixed front	Fixed rear	Drawout front	Drawout rear	Fixed front	Fixed rear	Drawout front	Drawout rear
MasterPacT MTZ1				MasterPacT MTZ2, MTZ3			

Type of accessories

Vertical connection adapters

Vertical connection adapters are used for simplifying the connection to a set of vertical busbars. They are mounted on front-connected MTZ1 devices or chassis. The adapters can be oriented either towards the front or the back of the device. When oriented towards the front of the fixed devices, the use of arc chute screen is compulsory.

Cable lug adapters

Cable lug adapters are used for simplifying the connection of cables fitted with lugs. They are mounted on the vertical-connection adapters on front-connected devices or chassis. To ensure adequate mechanical strength, the cable lug adapters must be secured together via spacer (part number 04691). The cable lug adapters must not go over the arc chute screen (see "Dimensions" chapter in this catalog).

Spreaders

When the connection bar is wider than the terminal, or a higher pole pitch is needed, spreaders can be mounted on the front or rear terminals of MTZ1 devices.

Disconnectable front connection adapter

Disconnecting a rear connected circuit breaker for maintenance or replacement can be complicated if there is no rear access to the switchboard. To avoid this complication, front connectors and disconnectable adapters can be used together as shown in the picture. In this case, the circuit breaker can be easily disconnected from the front of the switchboard.



<input checked="" type="checkbox"/>	<input type="checkbox"/>	<input checked="" type="checkbox"/>	<input type="checkbox"/>	<input type="checkbox"/>	<input type="checkbox"/>	<input type="checkbox"/>	<input type="checkbox"/>
-------------------------------------	--------------------------	-------------------------------------	--------------------------	--------------------------	--------------------------	--------------------------	--------------------------



<input checked="" type="checkbox"/>	<input type="checkbox"/>	<input checked="" type="checkbox"/>	<input type="checkbox"/>	<input type="checkbox"/>	<input type="checkbox"/>	<input type="checkbox"/>	<input type="checkbox"/>
-------------------------------------	--------------------------	-------------------------------------	--------------------------	--------------------------	--------------------------	--------------------------	--------------------------



<input checked="" type="checkbox"/>	<input checked="" type="checkbox"/>	<input checked="" type="checkbox"/>	<input checked="" type="checkbox"/>	<input type="checkbox"/>	<input type="checkbox"/>	<input type="checkbox"/>	<input type="checkbox"/>
-------------------------------------	-------------------------------------	-------------------------------------	-------------------------------------	--------------------------	--------------------------	--------------------------	--------------------------



<input type="checkbox"/>	<input type="checkbox"/>	<input type="checkbox"/>	<input type="checkbox"/>	<input checked="" type="checkbox"/>	<input type="checkbox"/>	<input type="checkbox"/>	<input type="checkbox"/>
--------------------------	--------------------------	--------------------------	--------------------------	-------------------------------------	--------------------------	--------------------------	--------------------------

[1] Spreaders, vertical connection adapters and cable lug adapters cannot be used when the voltage is ≥ 500 V.
 [2] MTZ1 spreaders are not compatible with interface barriers.
 [3] Mandatory for voltage ≥ 500 V. Not compatible with spreaders.
 [4] Except for MTZ2 40 equipped with horizontal rear connections and for fixed MTZ3 40-63.
 [5] Mandatory for fixed MTZ1 front connection versions with vertical connection adapters oriented towards the front.

Customize your Circuit Breaker with Accessories

Design and installation simplification

Connection

Mixed connection

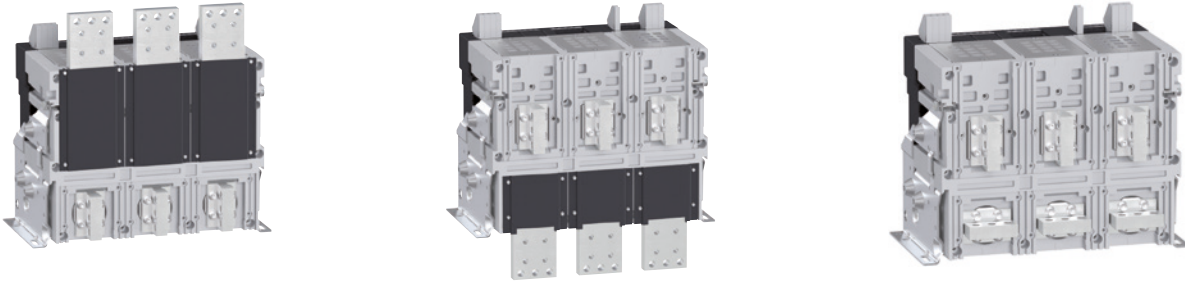

Mixed connection. Top and bottom can have different connection types



Type of accessories

Interphase barriers

To reinforce the isolation of connecting points, interphase barriers can be installed vertically between rear connection terminals. The bendable interphase barriers offer more flexibility when installing the busbars. The busbars can be insulated or not.

They are mandatory for MTZ1 devices at voltages ≥ 500 V.

Interphase barriers are not compatible with:

- Spreaders on MTZ1
- Front connections on drawout-version MTZ1
- Front connections on MTZ2
- Horizontal connections on MTZ2 40
- Fixed-version MTZ3.

Arc chute screen

When the breaker trips with high current, hot gas is generated and pushed up to the terminals through the filter. A flashover can occur between different terminals.

An arc chute screen blocks the hot air and prevents the generation of an arc between the terminals. For the drawout version, an additional arc chute screen is not necessary as the filter is already covered. For the fixed-type MasterPacT MTZ1 with front-connection and vertical-connection adapters oriented towards the front, it is mandatory to respect the clearance distances.

Mounting brackets

When mounting a circuit breaker at the back, mounting brackets can be installed on the backplates to simplify the installation. Only applicable for MTZ2 08 to 32.

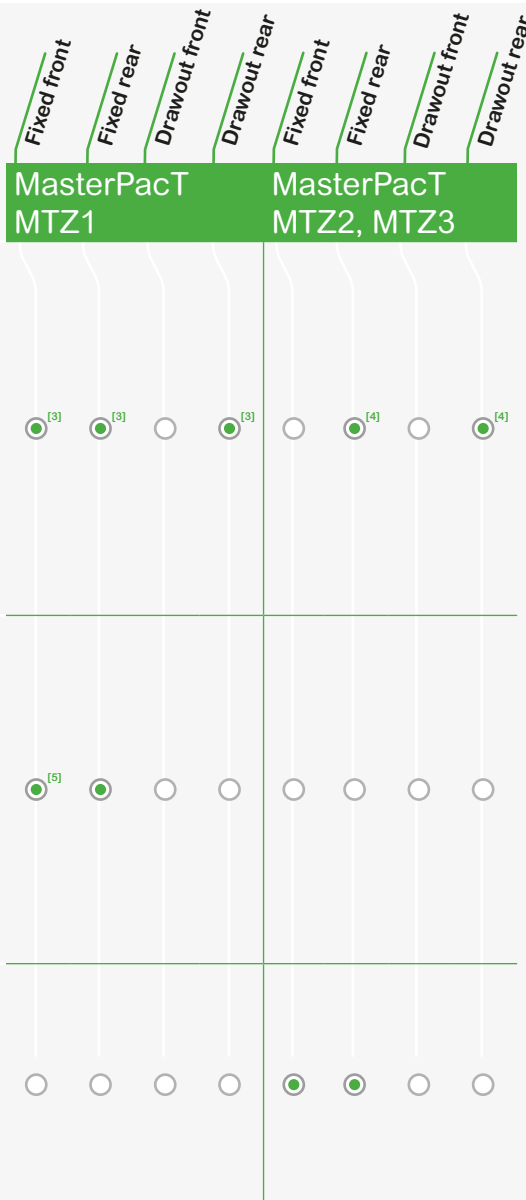

Operation efficiency

Signalling

Efficient day-to-day operation is vital. It means precise, on-time and accessible data about the status of the circuit breaker and fast action without the limitation of physical location. MasterPacT further increases the operation efficiency of the circuit breaker through signalling and control accessories.

Signalling

Signalling accessories provide status indications for both the device and the chassis. The accessories listed below are available to achieve efficiency objectives. Combinations of contacts are possible depending on the requirements.

- On/Off position of the main poles of the circuit breaker - OF
- Fault trip of the circuit breaker - SDE
- Combined connected/closed position of the circuit breaker (for MTZ 2/3 only) - EF
- Connected, disconnected and test positions of the chassis – CE, CD, CT
- Threshold overruns or status change through BCIM
- Indication ERMS engaged through BCIM
- Ready-to-close contact - PF
- Operation counter - CDM

OF, EF, CE, CD, CT, SDE and PF are available:

- In the standard version for relay applications
- In a low-level version for controlling PLCs and electronic circuits.

MasterPacT MTZ2 drawout version as an example

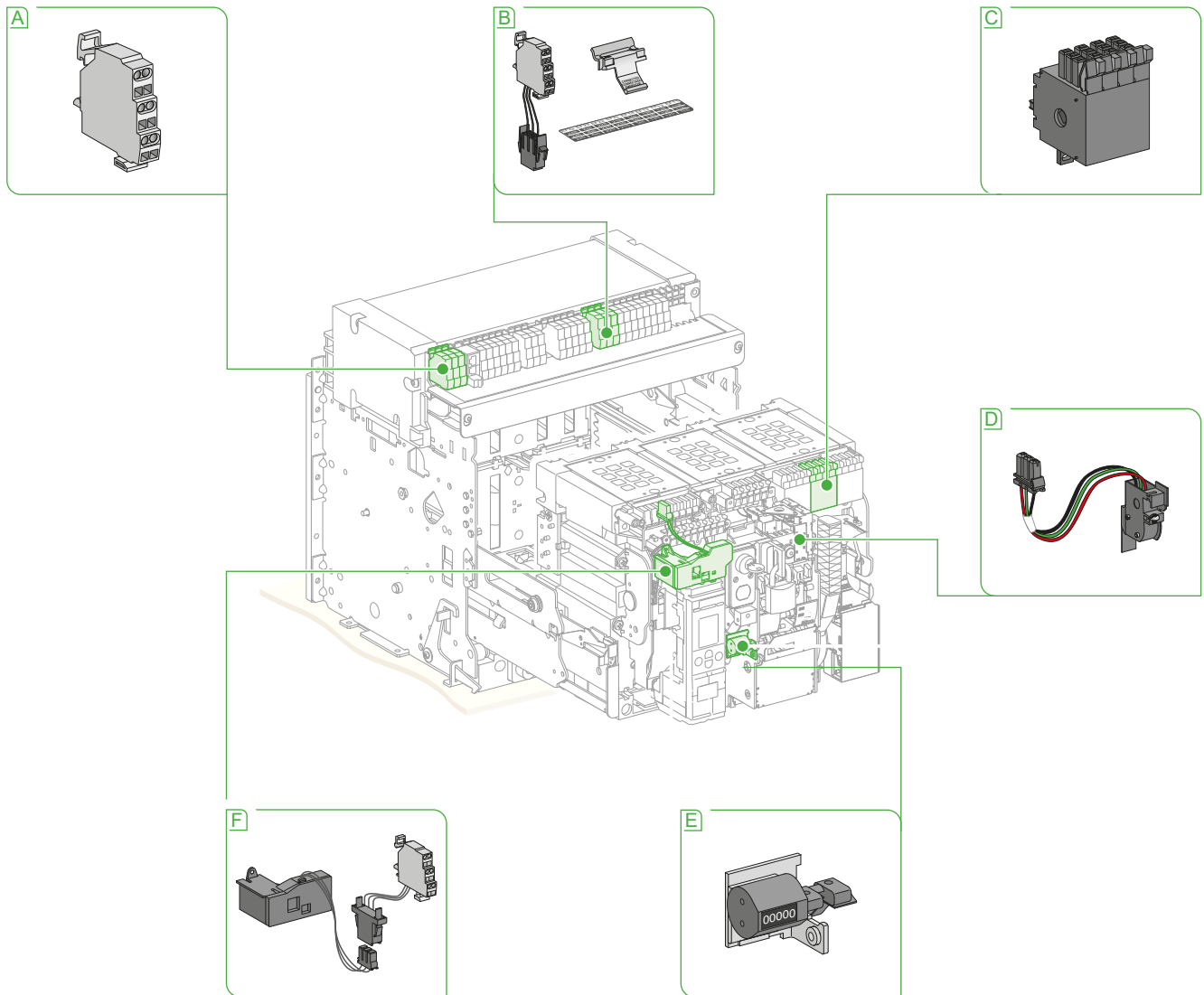

A CE, CD - Carriage switches

C OF - ON/OFF indication contacts

E CDM - mechanical operation counter

B EF - combined connected/closed contacts

D PF - ready-to-close contact

F SDE - fault-trip indication contact

Operation efficiency Signalling

ON/OFF indication contacts OF

Two types of contacts indicate the ON and OFF position of the circuit breaker:

- Microswitch-type changeover contacts available as standard and low-level versions for MasterPacT MTZ1
- Rotary-type changeover contacts for MasterPacT MTZ2/3. These are driven directly by a mechanism and switch when the minimum isolation distance between the main poles of the circuit breaker is reached.
- Four OF contacts are provided in the basic configuration for all the MasterPacT circuit breakers.
- For MTZ1, no additional OF contacts can be added. However, low-level OF contacts can replace the standard OF contacts. A mix of low-level contacts and standard contacts is possible.
- For MTZ2/3, the rotary-type changeover contacts can be used in both standard and low-level versions. In addition to the 4 OF contacts provided for the basic configuration, two optional blocks of 4 contacts can be added to the circuit breaker. This gives 12 OF contacts maximum. When EIFE is installed, as it occupies two OF positions, the maximum number of OF contacts is limited to 10.

OF		MTZ1		MTZ2/3	
Type		Standard microswitch type	Low-level microswitch type	Rotary-type contacts by default	Additional rotary-type contacts
Number		By default 4	Maximum 4	By default 4	Maximum 8
Minimum load		100 mA/24 V	2 mA/15 V	2 mA/15 V	2 mA/15 V
Breaking capacity (A)	V AC	240/380	6	5	10
		480	6	5	10
		690	6	5	6
p.f.: 0.3	V DC	24/48	2.5	5/2.5	10
AC-12/		125	0.5	0.5	10
DC-12 ^[1]		250	0.3	0.3	3

Fault-trip indication contacts SDE

Circuit breaker tripping following a fault is signalled by:

- Local indication given by a blue mechanical fault indicator (reset)
- Remote indication given by a changeover contact SDE

Following tripping, the mechanical indicator must be reset before the circuit breaker can be closed. One standard-level SDE (SDE1) is supplied in the basic circuit breaker configuration. An optional SDE (SDE2, standard or low level) can be added.

Note: SDE2 is incompatible with the option (RES) for electrical reset after a fault trip, see page C-11. Details of RES are explained on page C-22.

SDE		MTZ1, MTZ2, MTZ3	
Supplied as standard			1
Maximum number			2
Breaking capacity (A)	Standard		Minimum load: 100 mA/24 V
p.f.: 0.3	V AC	240/380	6
AC-12/DC-12 ^[1]		480	2
	V DC	24/48	3
		125	0.3
		250	0.15
	Low-level		Minimum load: 2 mA/15 V
	V AC	24/48	3
		240	3
		380	3
	V DC	24/48	3
		125	0.3
		250	0.15

[1] Utilization category according to IEC 60947-5-1.



ON/OFF indication contacts (OF) (microswitch type) - MTZ1

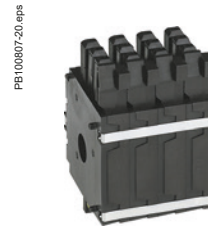

ON/OFF indication contacts (OF) (rotary type) - MTZ2 and MTZ3

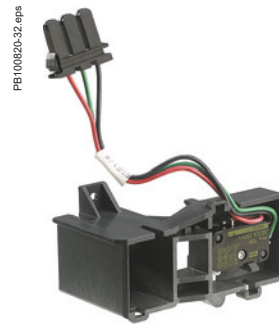

Additional fault-trip indication contacts (SDE)



Operation efficiency Signalling

PB100816-32.eps



Combined contacts.



PB100817-32.eps



CE, CD and CT connected/disconnected/test position carriage switches.

Combined connected/closed contacts EF

The contact combines the *device connected* and the *device closed* information to produce the *circuit closed* information. Supplied as an option for MasterPacT MTZ2/3, it is installed in the position for the connector of an additional OF contact.

Note: Ordering of additional OF contacts is compulsory if EF is selected. The maximum number of EF accessories is the number of additional OF contacts.

EF		MTZ2, MTZ3		
Maximum number		8		
Breaking capacity (A) p.f.: 0.3 AC-12/DC-12 ^[1]	Standard	Minimum load: 100 mA/24 V		
		V AC	240/380	6
			480	6
			690	6
		V DC	24/48	2.5
			125	0.8
			250	0.3
	Low-level	Minimum load: 2 mA/15 V		
		V AC	24/48	5
			240	5
			380	5
		V DC	24/48	2.5
			125	0.8
			250	0.3

Carriage switches for connected, disconnected and test positions

As standard, the connected, disconnected and test positions are shown by a mechanically indexed indicator. It shows the exact position when the racking handle is blocked.

In addition, three types of optional auxiliary contacts (both standard and low level) are available to indicate the position of the chassis:

- Changeover contacts to indicate the connected position CE,
- Changeover contacts to indicate the disconnected position CD. This position is indicated when the required clearance for the isolation of the power and auxiliary circuits is reached,
- Changeover contacts to indicate the test position CT. In this position, the power circuits are disconnected and the auxiliary circuits are connected.

Contacts		MTZ1, MTZ2, MTZ3 CE/CD/CT		
Breaking capacity (A) p.f.: 0.3 AC-12/DC-12 ^[1]	Standard			
		V AC	240	8
			380	8
			480	8
			690	6
		V DC	24/48	2.5
			125	0.8
			250	0.3
	Low-level			
		V AC	24/48	5
			240	5
			380	5
		V DC	24/48	2.5
			125	0.8
			250	0.3

[1] Utilization category according to IEC 60947-5-1.

Operation efficiency Signalling

Carriage switches for connected, disconnected and test positions

MTZ1

1	2	3	4	5	6	7	8	9	10	11	12	13	14	15	16	17	18	19	20	21	22
CE	CE	COM	UC1	UC2	SDE		UC3	SDE	MX	MX	XF	PF	MCH	OF	OF	OF	OF	CD	CD	CE	CT
					RES	UC4			MN									EIFE			

As shown in the table above, the carriage switches can be installed in six positions: 1, 2, 19, 20, 21 and 22. Each position corresponds to a particular type of auxiliary contact (CE, CD, CT). When EIFE is installed, it takes the place of one CD at position 19, one CE at position 21 and one CT at position 22. The CD, CE, CT switches are directly connected to EIFE which makes the information available through the Ethernet communication bus.

Position	Without EIFE	With EIFE
1	None or 1 CE	None or 1 CE
2	None or 1 CE	None or 1 CE
19	None or 1 CD	None
20	None or 1 CD	None
21	None or 1 CE	None
22	None or 1 CT	None

Note: Any standard contact can be replaced by a low-level contact except for those provided by EIFE.

MTZ2 and MTZ3

1	2	3	4	5	6	7	8	9	10	11	12	13	14	15	16	17	18	19	20	21	22	23	24	25	26	27	28	29	30	31	32	33	34		
CD	CD	CD	COM	UC1	UC2	SDE	UC4	UC3		SDE	CE	CE	CE	MN	MX	XF	PF	MCH	OF	OF	OF	OF	OF	OF	OF	OF	OF	OF	OF	OF	OF	CT	CT	CT	
CE	CE	CE				RES					CT	CT	CT	MX					EF	EF	EF	EF	EF	EF	EF	EF				CD	CE	CE	CE		
																																CD	CD	CD	
																																			EIFE

As shown in the table above, the carriage switches can be installed in three blocks:

- Position 1, 2 or 3 for the first block.
- Position 12, 13 or 14 for the second block.
- Position 32, 33 or 34 for the third block.

As standard, a maximum of three CD switches can be installed in the first block, a maximum of three CE switches can be installed in the second block, and a maximum of three CT switches can be installed in the third block.

Changing the functions of the carriage switches is possible. In this case, the first block can be replaced by CE, the second block can be replaced by CT and the third block can be replaced by CE or CD.

Mixing of CE, CD, CT in one block is not possible. For example, installing one CD and two CE switches in the first block is not possible.

When EIFE is installed, it occupies the position of CT, CE and CD switches in positions 32, 33 and 34.

The CD, CE, CT switches are directly connected to EIFE which makes the information available through the Ethernet communication bus. As EIFE also occupies positions 30 and 31, OF cannot be installed in these positions and the maximum number of OF contacts is limited to 10.

Block: Position	Without EIFE	With EIFE
1: 1, 2, 3	None or 1 CD or 2 CD or 3 CD or 1 CE or 2 CE or 3 CE	None or 1 CD or 2 CD or 3 CD or 1 CE or 2 CE or 3 CE
2: 12, 13, 14	None or 1 CE or 2 CE or 3 CE or 1 CT or 2 CT or 3 CT	None or 1 CE or 2 CE or 3 CE or 1 CT or 2 CT or 3 CT
3: 32, 33, 34	None or 1 CT or 2 CT or 3 CT or 1 CE or 2 CE or 3 CE or 1 CD or 2 CD or 3 CD	None

Note: Any standard contact can be replaced by a low-level contact except for those provided by EIFE.

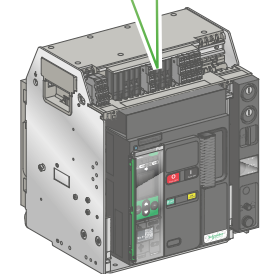
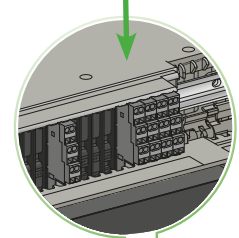

DB439866.ai

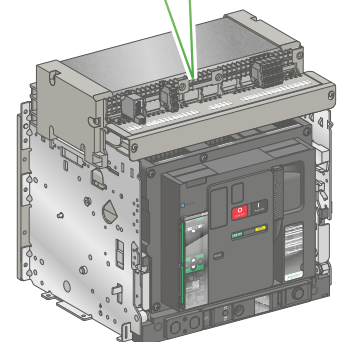
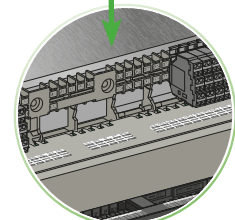

DB439867.ai

Operation efficiency Signalling

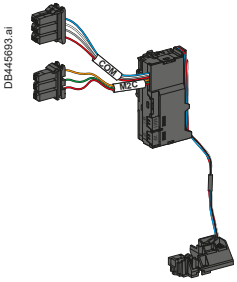

BCIM

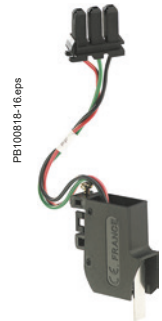

Ready-to-close contacts PF



Operation counter CDM

Breaker Communication and Isolation Module

The Breaker Communication and Isolation Module (BCIM) ensures that the trip unit in the circuit breaker communicates correctly with the external interface along with the native Input/Output functionality.

This module provides 12 kV isolation on the ULP protocol from the trip unit.

Two digital Inputs/Outputs are available on BCIM. They can be configured in order to:

- Engage/disengage ERMS and share its status
- Track protection alarms
- Open/close the breaker

Ready-to-close contact PF

The ready-to-close function ensures that the breaker will close only when all the necessary criteria are met.

It checks each prerequisite for closing the circuit breaker and informs the user when it is ready to close.

It consists of a mechanical indicator and a PF changeover contact.

This indicator only displays a ready status when all the following conditions are met:

- The circuit breaker is in the OFF position
- The spring mechanism is charged
- A maintained opening order is not present.

This indicator will not display a ready status when any of the following conditions are met:

- Voltage release MX energized
- A fault trip has occurred
- Remote tripping by a second MX or MN voltage release has occurred
- Device not completely racked in
- Device locked in OFF position
- Device interlocked with a second device.

Note: Details of MX are presented on page D-18.

PF	MTZ1, MTZ2, MTZ3		
Maximum number	1		
Breaking capacity (A)	Standard - Minimum load: 100 mA/24 V		
p.f.: 0.3	V AC	240/380	480
AC-12/DC-12 [1]	V DC	5	2
		24/48	125 250
		3	0.3 0.15
	Low-level - Minimum load: 2 mA/15 V		
	V AC	24/48	240
		3	3
	V DC	24/48	125
		3	0.3

[1] Utilization category according to IEC 60947-5-1.

Operation counter CDM

The operation counter sums the number of operating cycles and is visible on the front panel. It is compatible with manual and electrical control functions.

This option is compulsory for source-changeover systems.

Operation efficiency Controlling

Control accessories provide multiple ways of controlling the circuit breaker and the option to operate it remotely. Two control devices are presented here:

- Remote On/Off
- Remote reset after fault tripping

DB-446694-1a1

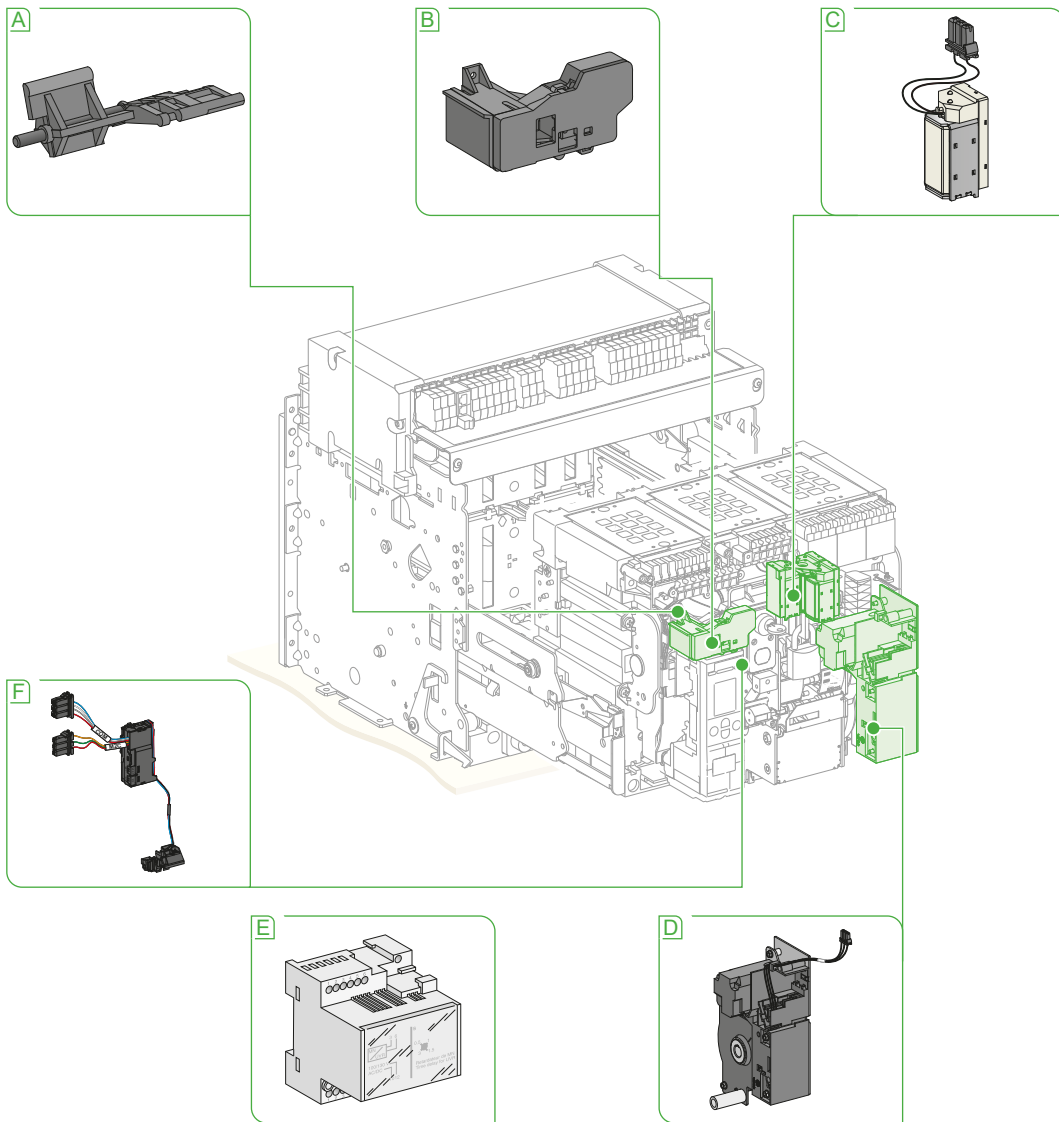

- | | | |
|--|--|---|
| <p>A RAR - automatic reset option</p> <p>B RES - electric reset option</p> <p>C ■ XF - standard closing voltage release
■ XF - reinforced closing voltage release</p> | <p>■ MX - standard opening voltage release
■ MX - reinforced opening voltage release second MX</p> <p>■ MN - standard undervoltage release
■ MN - reinforced undervoltage release</p> <p>D MCH - gear motor</p> | <p>E ■ R - non-adjustable delay unit
■ Rr - delay unit adjustable for MN undervoltage release.</p> <p>F BCIM - Breaker communication and isolation module</p> |
|--|--|---|

Operation efficiency Controlling

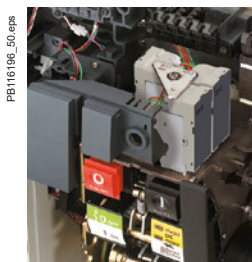

PB161696_50.eps

Remote ON/OFF

Various solutions are possible that use different combinations of the accessories below.

- **Basic voltage release** to voltage release open and close orders:
 - XF - closing voltage release
 - MX - opening voltage release
 - MN - undervoltage release

The circuit breaker can be equipped with:

- An XF voltage release,
- An MX voltage release,
- A 2nd MX voltage release or an MN undervoltage release.

- **Diagnostic & Communicating voltage release** with diagnostic and communication functions in addition to releasing open and close orders:

- XF diag&com - diagnostic and communicating closing voltage release
- MX diag&com - diagnostic and communicating opening voltage release

The diagnostics and communicating voltage release require the installation of the insulation module.

The circuit breaker can be equipped with:

- An XF diag&com voltage release,
- An MX diag&com voltage release

Note: MN undervoltage release and MN diagnostic undervoltage release can be used with non adjustable and adjustable delay unit R or Rr.

- **Electric Motor** to charge the spring:

- Electric motor MCH

- **Signalling Accessories** are often added to enhance convenience and safety:

- Ready-to-close contact PF
- Device ON/OFF indication OF
- Fault-trip indication SDE

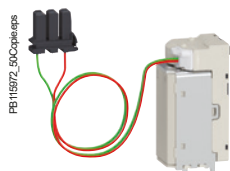

FB11972_50Cape.eps

XF, MX and MN

Solutions

Three remote control solutions are provided by MasterPacT MTZ Active.

Customer wiring with basic voltage release (XF, MX, MN)

MasterPacT MTZ Active can be opened and closed remotely by using the output contacts of a PLC or a pushbutton wired to the voltage release (MX, MN, XF).

This solution requires hard wiring between the circuit breaker and the location from where the operation is conducted.

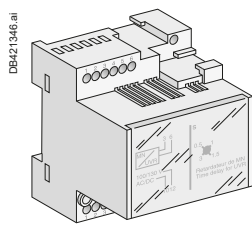

DB421346.ai

Adjustable or non-adjustable delay unit

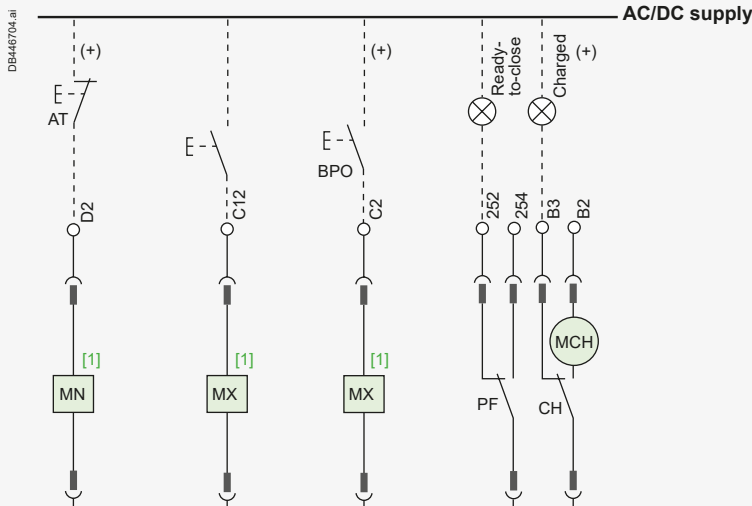

[1] The maximum lengths of the wiring between the AC/DC power supply and voltage release terminals A1-A2 / C1-C2 / C11-C12 / D1-D2 are given page D-18.

Operation efficiency Controlling

Customer wiring with voltage release with diagnostic function (XF diag&com, MX diag&com, MN diag)
When voltage release with diagnostic functions are used in customer wiring, the following diagnosis information is available in addition to remote operation. The information can be accessed through the MicroLogic MTZ Active HMI, wireless communication, and EcoStruxure Power Commission through USB connection.

- Identify the type of the voltage release, MX diag&com, XF diag&com.
- Detect whether the voltage release is functioning properly by comparing the voltage release order and the opening/closing status of the circuit breaker.
- Check whether there is any breakage of the wiring in the voltage release periodically (every 30 seconds).

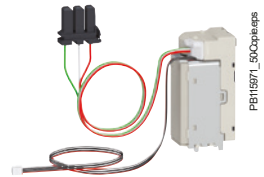

XF diag&com,
MX diag&com

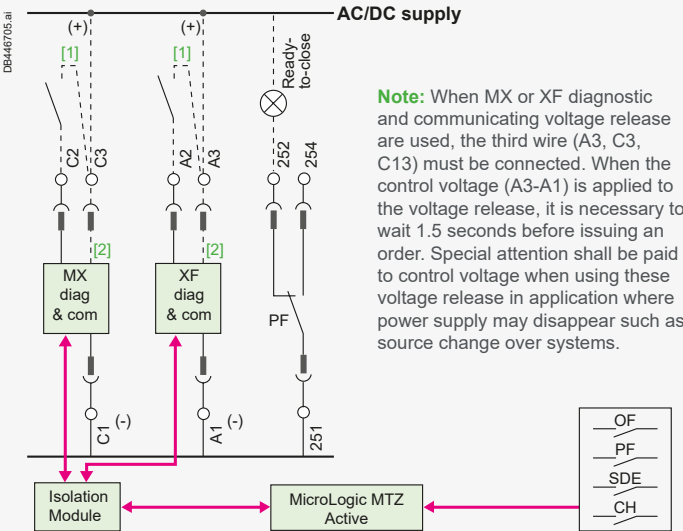

Communication Bus connection with diagnostic & communication voltage release (XF diag&com, MX diag&com)

When a communication system is present, the MasterPact MTZ Active can be opened and closed from a remote control system such as a SCADA, through the communication bus.

In addition to the functionalities of the previous solution, this solution brings the following benefits:

- Bus solution provides more flexibility geographically and saves wiring costs
- Diagnosis information can be accessed remotely through the communication network but not from the MicroLogic MTZ Active HMI.

A bus solution and point-to-point solution can be implemented together when using communication voltage release.

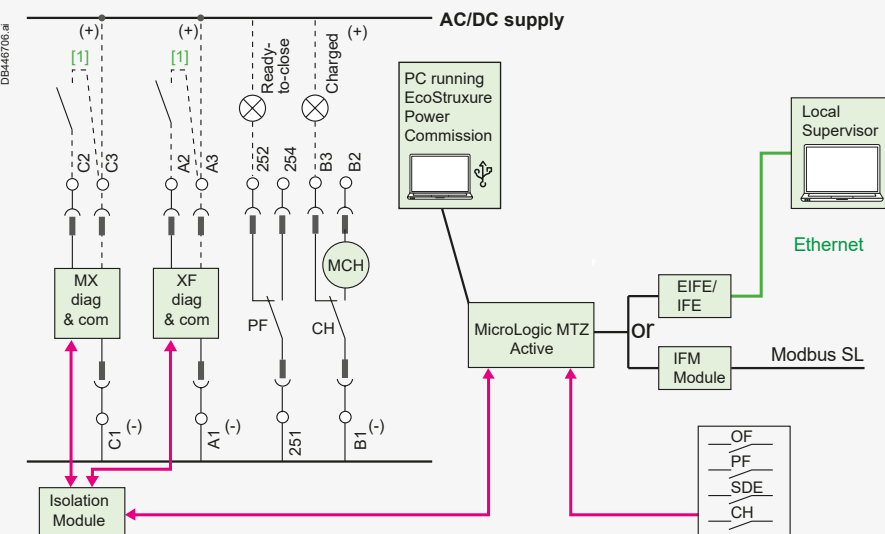

[1] Maximum length of the two wires cables between A2-A3 / C2-C3: 5 m.

[2] The maximum lengths of the wiring between the AC/DC power supply and voltage release terminals A1-A3 are given page D-18.



Operation efficiency

Controlling

The table below summarizes all the possibilities for controlling the On/Off status of a breaker in different operating modes.

Connection	Voltage release	Method	MicroLogic MTZ Active Operation Mode Setting			Exclusiveness ^[1]	Diagnostic Information ^[2]
			Manual	Auto Local	Auto Remote		
Customer wiring	Basic voltage release (XF, MX)	Pushbutton	⊙	⊙	⊙		
		Wireless pushbutton (XB5)	⊙	⊙	⊙		
	Diagnostic & Communicating voltage release (XF diag&com, MX diag&com)	Pushbutton	⊙	⊙	⊙		⊙
		Wireless pushbutton	⊙	⊙	⊙		⊙
		EcoStruxure Power Commission via USB		⊙		⊙	⊙
		Ecostruxure Power Device App app (USB)		⊙		⊙	⊙
Bus solution with COM communication option	Diagnostic & Communicating voltage release (XF diag&com, MX diag&com)	BPFE via MicroLogic		⊙	⊙		⊙
		SCADA via IFE/EIFE/IFM			⊙	⊙	⊙
		EcoStruxure Power Commission via IFE/EIFE			⊙	⊙	⊙
		Webpage via IFE/EIFE			⊙	⊙	⊙
		Ecostruxure Power Device App app (USB)		⊙		⊙	⊙

[1] Exclusiveness means that the operation can only be done in one particular operating mode. For example, when customer wiring with basic voltage release is used, On/Off operation of the breaker using the pushbutton has no exclusiveness as it can be done in all three operating modes.

[2] Details of diagnostic functions can be found on the previous page.



Selection of voltage release

Three common user cases are presented here to illustrate the possible choice of voltage release.

User case I: Remote Opening

This case is applicable when only remote opening is required. It is necessary to respond to an emergency. This solution enables the emergency opening of the circuit breaker.

User case II: Remote Opening and Closing

When both remote opening and remote closing are required, this solution can be implemented. As the spring needs to be charged to close the circuit breaker, an electric motor MCH needs to be installed in this solution.

User Case III: Remote closing and opening with 2nd MX or MN voltage release

For safety reasons, redundancy of mechanisms is required in certain installations.

	Customer wiring with basic voltage release	Customer wiring with diagnostic & communicating voltage release	Communication bus connection with diagnostic & communicating voltage release
User Case I: Remote Opening	Option I: <ul style="list-style-type: none"> Opening voltage release MX Option II: <ul style="list-style-type: none"> Instantaneous undervoltage release MN 	Option I: <ul style="list-style-type: none"> Opening voltage release MX diag&com Option II: <ul style="list-style-type: none"> Instantaneous undervoltage release MN 	Option I: <ul style="list-style-type: none"> Opening voltage release MX diag&com
User Case II: Remote Opening and Closing	Option I: <ul style="list-style-type: none"> Opening voltage release MX Closing voltage release XF Electric motor MCH Option II: <ul style="list-style-type: none"> Instantaneous undervoltage release MN Closing voltage release XF Electric motor MCH 	Option I: <ul style="list-style-type: none"> Opening voltage release MX diag&com Closing voltage release XF diag&com Electric motor MCH Option II: <ul style="list-style-type: none"> Instantaneous undervoltage release MN Closing voltage release XF diag&com Electric motor MCH 	Option I: <ul style="list-style-type: none"> Opening voltage release MX diag&com Closing voltage release XF diag&com Electric motor MCH
User Case III: Remote Closing and Opening with 2 nd MX or MN voltage release	Option I: <ul style="list-style-type: none"> Opening voltage release MX Closing voltage release XF Electric motor MCH Instantaneous undervoltage release MN or a second MX diag&com voltage release 	Not supported with diag&com coils.	Not supported with diag&com coils.

Note:

- Adjustable or non adjustable delay unit can be added to MN and MN diag in all situations.
- An isolation module is required for all connections between MicroLogic MTZ Active and diagnostic & communicating voltage release (XF diag&com, MX diag&com).

Operation efficiency

Controlling

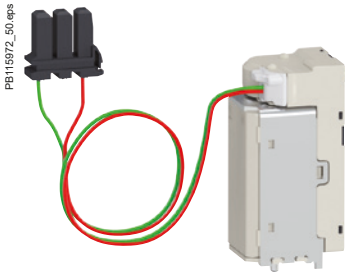

Voltage releases

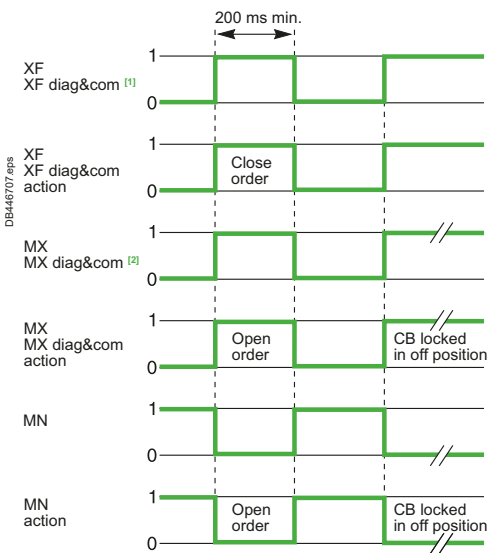

[1] For XF diag&com the supply shall be present between terminals A1-A3.
 [2] For MX diag&com the supply shall be present between terminals C1-C3.

Basic voltage release and diagnostics & communication voltage release general characteristics

After receiving the command, the closing/opening voltage release instantaneously triggers the mechanism to close/open the circuit breaker. For MN, it also opens the circuit breaker when its supply voltage drops to a value between 35 % and 70 % of its rated voltage. Circuit breaker closing is possible only when the supply voltage of the voltage release returns to 85 % of its rated value.

- MN undervoltage release locks the circuit breaker in OFF position when it is not energized.
- MX opening voltage release can lock the circuit breaker in OFF position if the order is maintained.

The XF, MX, MN, XF diag&com, MX diag&com, voltage release require a power supply separate from the MicroLogic MTZ Active power supply.

Note: The minimum duration of the pulse operating order must be 200 ms.

Characteristics	XF, XF diag&com	MX, MX diag&com
Power supply V AC 50/60 Hz	24 - 48 - 100/130 - 200/250 - 277 - 380/480	
V DC	24/30 - 48/60 - 100/130 - 200/250	
Operating threshold	0.85 to 1.1 Un	0.7 to 1.1 Un
Consumption (VA or W)	Hold: 4.5 Pick-up: 200 (200 ms)	Hold: 4.5 Pick-up: 200 (200 ms)
Circuit breaker response time at Un	MTZ1: 55 ms Max=65 ms MTZ2: 70 ms Max=80 ms MTZ3: 80 ms Max=90 ms	50 ms Max=60 ms

Characteristics	MN
Power supply V AC 50/60 Hz	24 - 48 - 100/130 - 200/250 - 380/480
V DC	24/30 - 48/60 - 100/130 - 200/250
Operating threshold	Opening: 0.35 to 0.7 Un Closing: 0.85 Un
Consumption (VA or W)	Hold: 4.5 Pick-up: 200 (200 ms)
MN consumption with delay unit (VA or W)	Hold: 4.5 Pick-up: 200 (200 ms)
Circuit breaker response time at Un	40 ms Max=45 ms (MasterPacT MTZ1) 90 ms Max=95 ms (MasterPacT MTZ2, MTZ3)

Recommended maximum cable lengths (m)					
		24 V 2.5 mm ²	1.5 mm ²	48 V 2.5 mm ²	1.5 mm ²
MN	U source 100 %	58	35	280	165
	U source 85 %	16	10	75	45
MX-XF, MX diag&com, XF diag&com	U source 100 %	115	70	550	330
	U source 85 %	75	44	350	210

Note: The indicated lengths are given for each of the two wires of the cables.

Diagnostic & communicating voltage release specificities

The new generation of communicating voltage release brings two major benefits compared with the basic voltage release, diagnostic and communication functions.

Diagnostic Function

Incorrect operation or failure of the voltage release can cause damage to the electric network. The new function of the diagnostic and communicating voltage release provides the diagnostic information and prevents incorrect operations that can damage the equipment.

These voltage release can perform the following diagnosis and communicate the results through MicroLogic MTZ Active.

- Identify the type of the voltage release, MX diag&com, XF diag&com
- Detect whether the voltage release is functioning properly by comparing the voltage release order and the opening/closing status of the circuit breaker
- Check whether there is any breakage of the wiring in the voltage release periodically (every 30 seconds)

Results can be read through all the different ways of retrieving information from MicroLogic MTZ Active as presented in chapter B, including HMI, wireless communication, and EcoStruxure Power Commission through a USB connection. If the voltage release are connected to the communication system, they can also be accessed through the communication system.

Communication function

In addition to hard wiring, these voltage release can be connected to the communication network. It allows the voltage release to be integrated in the communication system. It gives more flexibility for remote operations, and the diagnosis results mentioned in diagnostic function can be assessed remotely as well.

New voltage release action type

In addition to the diagnostic function, a major new feature of the new generation is the voltage release action type. The new generation no longer has the pulse-type voltage release; the voltage release can be maintained as long as the order is maintained. Because of the new feature, MX diag&com can lock the circuit breaker in the OFF position when the order is maintained.

MN delay units

To reduce circuit breaker nuisance opening during short voltage drops, MN delay units can be installed to delay the MN undervoltage release and only trigger the voltage release when voltage is low for a certain period of time. It can be disabled by an emergency OFF button to obtain instantaneous opening of the circuit breaker.

Two versions of the delay unit are available, adjustable and non-adjustable.

Characteristics		
Power supply V AC 50-60 Hz /DC	Non-adjustable	100/130 - 200/250
	Adjustable	48/60 - 100/130 - 200/250 - 380/480
Operating threshold	Opening	0.35 to 0.7 Un
	Closing	0.85 Un
Delay unit consumption	Pick-up: 200 (200 ms)	Hold: 4.5
Circuit breaker response time at Un	Non-adjustable	0.25 s
	Adjustable	0.5 s - 1 s - 1.5 s - 3 s

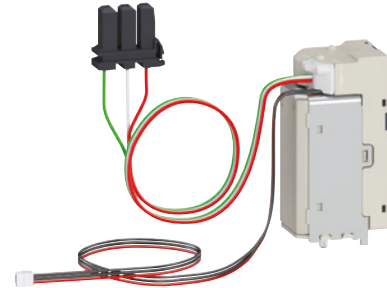

XF diag&com, MX diag&com

PB115971_50.eps

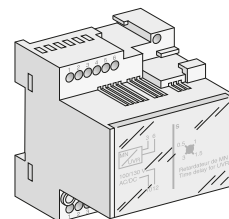

Adjustable or non-adjustable delay unit

DB421346.ai

Operation efficiency

Controlling

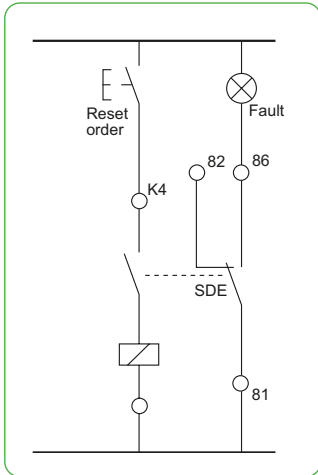

Remote reset after fault trip

DB4131-10.eps

Remote reset after fault trip

When a fault trip happens, the fault trip indicator SDE indicates *fault* and the blue fault trip reset button pops up. To close the breaker, the reset button needs to be pressed down.

To perform a remote reset after a fault trip, two solutions, RES and RAR, are provided.

Electric reset after fault trip RES

This function resets the SDE fault trip indication and voltage-releases the circuit breaker mechanism, the reset button goes in and circuit breaker closing is possible. A power supply of 100/130 V AC or 200/240 V AC is required to enable this function.

Note: The additional Fault Trip indication contact SDE2 is not compatible with RES.

Automatic reset after fault trip RAR

In the case of RAR, pressing the reset button is no longer required to enable the circuit breaker closing after tripping. The circuit breaker is closed with the Reset button still popped up and the SDE indication still indicating *fault*. The SDE indications will remain in the fault position until the reset button is pressed.

Note: To achieve remote closing after fault trip, closing voltage release XF and electric motor MCH are required in addition to RES or RAR.

Note: an opening order always takes priority over a closing order. If opening and closing orders occur simultaneously, the mechanism discharges without any movement of the main contacts. The circuit breaker remains in the open position (OFF).

In the event of maintained opening and closing orders, the standard mechanism provides an anti-pumping function by blocking the main contacts in the open position.

Anti-pumping function After fault tripping or intentional opening using the manual or electric controls, the closing order must first be discontinued, then reactivated to close the circuit breaker.

When the automatic reset after fault trip (RAR) option is installed, to avoid pumping following a fault trip, the automatic control system must take into account the information supplied by the circuit breaker before issuing a new closing order or blocking the circuit breaker in the open position (information on the type of fault, such as overload, short-time fault, ground fault, ground leakage, and short-circuit).

DB426440.ai

DB426339.ai

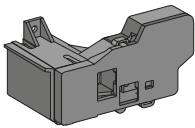

Electric reset after fault trip RES

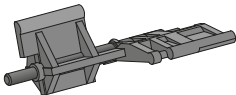

Automatic reset after fault trip RAR

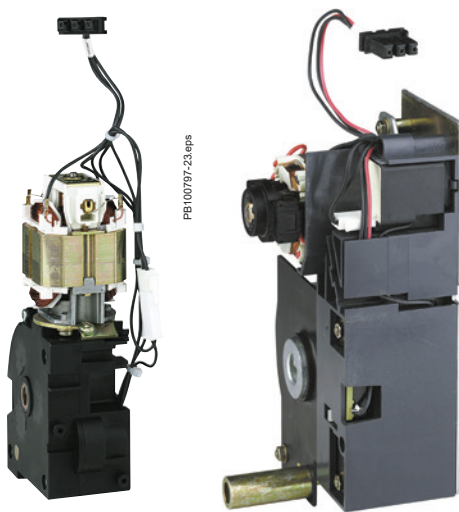

Electric motor MCH for MasterPacT MTZ1

Electric motor MCH for MasterPacT MTZ2 and MTZ3

PB100808-32.eps

Electric motor MCH

The electric motor automatically charges the spring mechanism when the circuit breaker is closed. This enables the instantaneous reclosing of the circuit breaker following opening. The spring-mechanism charging handle can be used as a backup if the auxiliary power supply is absent.

The electric motor MCH is equipped as standard with a limit switch contact CH that signals the charged position of the mechanism.

The electric motor MCH requires a power supply separate from the MicroLogic Active power supply.

Characteristics

Power supply	V AC 50/60 Hz	48/60 - 100/130 - 200/240 - 277 - 380/415 - 400/440 - 480
	V DC	24/30 - 48/60 - 100/125 - 200/250
Operating threshold	0.85 to 1.1 Un	
Consumption (VA or W)	180	
Motor overcurrent	2 to 3 In for 0.1 s	
Charging time	maximum 3 s for MasterPacT MTZ1	
	maximum 4 s for MasterPacT MTZ2, MTZ3	
Operating frequency	maximum 3 cycles per minute	
CH contact	10 A at 240 V	

Protection of people and property

Locking and interlocking



Protection is always the priority. MasterPacT MTZ provides a high degree of protection for both people and property by the following means:

- Locking and Interlocking
- Circuit Protection
- Operational Protection
- Mechanical Protection.

Locking and interlocking

It is of great importance to ensure that the circuit breaker is only operated by a certified and authorized person. It is for both the protection of the operator and the protection of property. Another important aspect is to minimize the chances of incorrect operation which may lead to a major safety risk.

Locking and interlocking accessories ensure that the circuit breaker is operated by the right person at the right time in accordance with local rules and regulations.

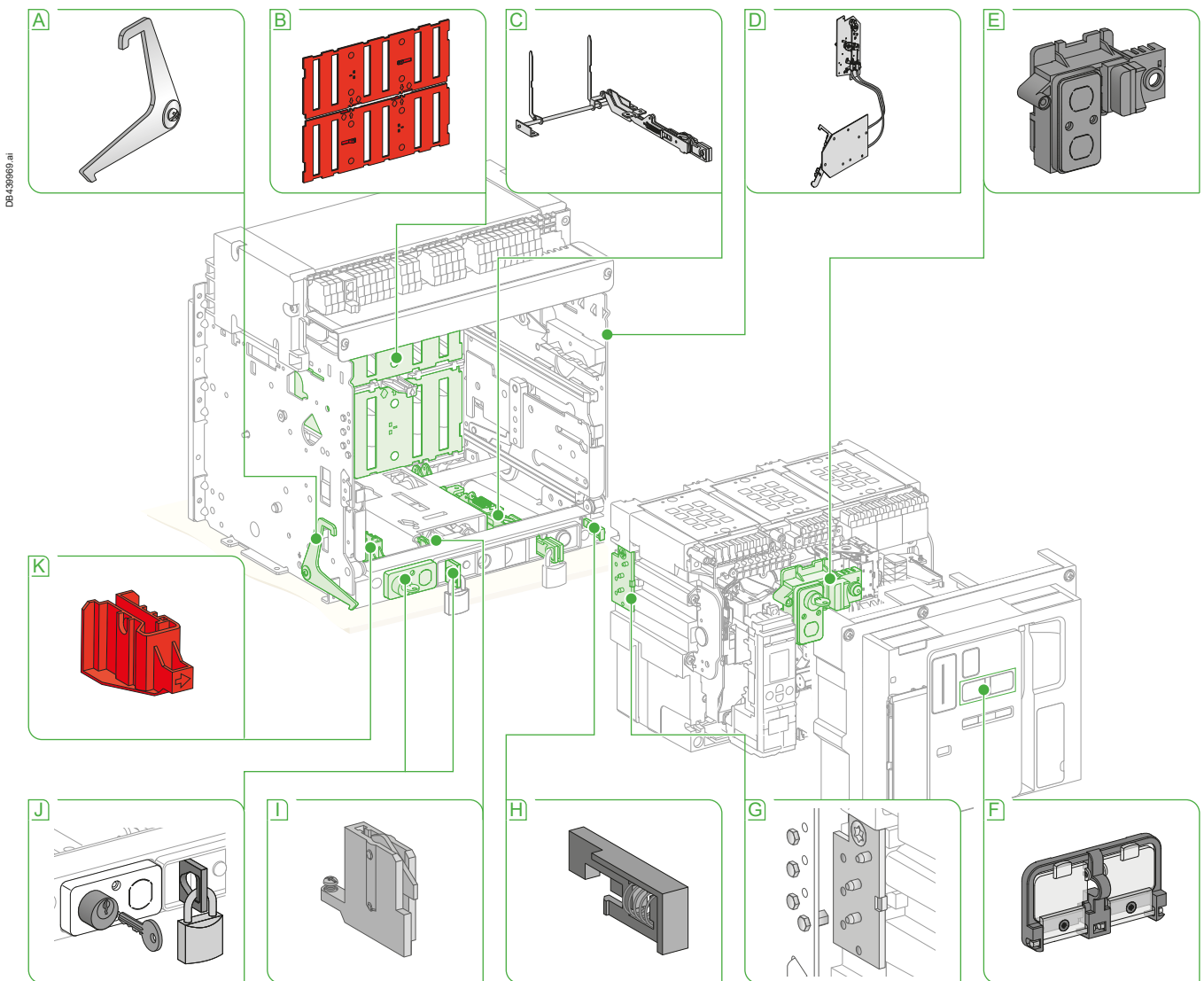

- | | | |
|---|---|--|
| A VPEC - door interlock catch | E VCPO/VSPO - OFF position locking | I IBPO - interlock between racking handle and OFF pushbutton |
| B VO - safety shutters | F VBP - ON/OFF pushbutton locking | J ■ VSPD - Chassis locking in disconnected position, by keylock |
| C VIVC - shutter position indication and locking | G V DC - mismatch protection | ■ Chassis locking in disconnected position, by padlock |
| D IPA - cable-type door interlock | H VPOC - racking interlock | K Shutter locking block |

Protection of people and property

Locking and interlocking

Pushbutton locking VBP

Open and close pushbuttons can be blocked by using VBP. It consists of two transparent covers which can be locked with any of the following:

- Padlock (not supplied), 5 to 8 mm,
- Lead seal,
- Two screws.

The opening button and the closing button can be locked independently.

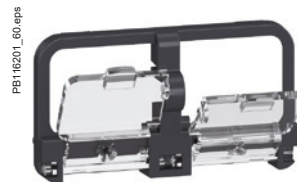

Access to pushbuttons protected by transparent cover VBP.

Device locking in the OFF position by padlocks (VCPO) or keylocks (VSPO)

The circuit breaker can be locked in the OFF position by physically maintaining the opening pushbutton pressed down:

- Using padlocks (one to three padlocks, not supplied), shackle Ø5 to 8 mm
- Using keylocks (one or two different keylocks, supplied).



Pushbutton locking with padlock VBP.

Keys may be removed only when locking is effective (Profalux or Ronis type locks). The keylocks are available in any of the following configurations:

- One keylock
- One keylock mounted on the device + one identical keylock supplied separately for interlocking with another device
- Two different keylocks for double locking.

Profalux and Ronis keylocks are compatible with each other.

A locking kit (without locks) is available for installing one or two keylocks (Ronis, Profalux, Kirk or Castell).



OFF position locking with padlock VCPO.

Accessory-compatibility

For MasterPacT MTZ1: 3 padlocks or 1 keylock.

For MasterPacT MTZ2, MTZ3: 3 padlocks and/or 2 keylocks.

For MTZ1, either keylock or padlock can be used. For MTZ2 and 3, padlock will always be available when keylock is selected. Padlock and keylock can be used at the same time.



OFF position locking with keylock VSPO.

Disconnected position locking with padlocks (standard) or keylocks (VSPD option)

The circuit breaker can be locked in its disconnected position by using the locks on the chassis. This feature is accessible via the cut-out door closed.

Two options are available:

- Using padlocks (standard), up to three padlocks (not supplied),
- Using keylocks (optional), one or two different keylocks are available.

Profalux and Ronis keylocks are available in different options:

- One keylock,
- Two different keylocks for double locking,
- One (or two) keylocks mounted on the device, and one (or two) identical keylocks supplied separately for interlocking with another device.

A locking kit (without locks) is available for installing one or two keylocks (Ronis, Profalux, Kirk or Castell).



Disconnected position locking with padlocks.

Locking in the connected, disconnected and test positions

The connected, disconnected and test positions are shown by an indicator and are mechanically indexed. The exact position is obtained when the racking handle is blocked. A release button is used to release it.

As standard, the circuit breaker can be locked only in the disconnected position by padlocks or by keylocks..

On request, the locking system may be modified to lock the circuit breaker in any of the three positions: connected, disconnected or test.



Disconnected position locking by keylocks VSPD.

Customize your Circuit Breaker with Accessories

Protection of people and property

Locking and interlocking



Safety shutters with padlocking VO

Safety shutters with padlocking VO

When the circuit breaker is in the disconnected or test position, there is the potential for an operator to accidentally touch the disconnected contact cluster or to accidentally slide it back to the connected position, posing a safety risk to the operator and to the installation.

Mounted on the chassis, safety shutters close automatically when the breaker is in the disconnected or test position. They ensure the insulation distance and physical segregation between the live parts and the compartment of the chassis (Degree of protection: IP 20).

The shutter-locking system locks the safety shutters in the closed position and prevents the insertion of the device. For MTZ1, safety shutters can be padlocked directly. For MTZ 2/MTZ3, the shutter-locking system is made up of separate parts that can be padlocked.

There are in total two blocks for MTZ2, three blocks for MTZ3-3P and four blocks for MTZ3-4P.

For MTZ 2/MTZ3, a support at the back of the chassis is used to store the blocks when they are not in use.



Shutter position indication and locking VIVC

Shutter position indication and locking VIVC

Alternatively, shutter position indication and locking (VIVC) can also be used to lock the safety shutters.

This device is installed on the chassis front plate and allows the locking operation to be performed from outside the chassis compartment. For MTZ2, the upper and lower shutters can be locked either independently or together, and their positions can be indicated independently. For MTZ3, the upper and lower shutters are locked together.

One to three padlocks can be used (padlocks are not supplied).

Note: This option is applicable for MTZ2/3 only.

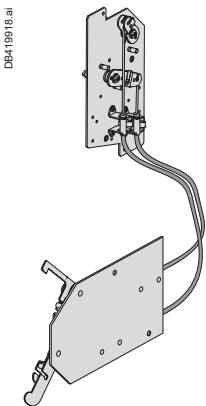

Cable-type door interlock IPA

Cable-type door interlock IPA

This option prevents door opening when the circuit breaker is closed and prevents circuit breaker closing when the door is open.

To implement this option, a special plate associated with a lock and a cable is mounted on the right side of the circuit breaker.

This option is not compatible with the source changeover function.

This option is identical for fixed and drawout versions.



Protection of people and property

Locking and interlocking

Racking interlock VPOC

This device prevents the insertion of the racking handle when the cubicle door is open.

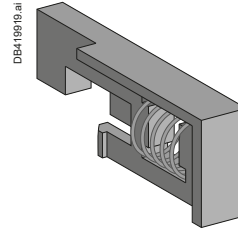

Racking interlock VPOC

Door interlock catch VPEC

Mounted on the right-hand or left-hand side of the chassis, this device prevents the opening of the cubicle door when the circuit breaker is in the connected or test position.

If the breaker is put in the connected position with the door open, the door may be closed without having to disconnect the circuit breaker.



Door interlock catch VPEC

Racking interlock between racking handle and OFF pushbutton IBPO (for MTZ2, MTZ3 only)

This option makes it necessary to press the OFF pushbutton in order to insert the racking handle and holds the device open until the handle is removed.

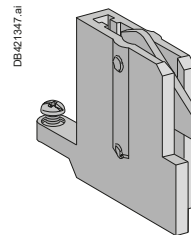

Racking interlock between racking handle and OFF pushbutton IBPO (for MTZ2, MTZ3 only)

Mismatch protection V DC

Mismatch protection ensures that a circuit breaker is inserted only in a chassis with compatible characteristics. It is made up of two parts (one on the chassis and one on the circuit breaker) offering twenty different combinations that the user may select from.



Mismatch protection V DC



Customize your Circuit Breaker with Accessories

Protection of people and property

Circuit protection

MicroLogic Active external sensors and voltage measurement inputs enlarge its protection functions. Instantaneous voltage release also prevents property from being damaged.



DB446700.ai

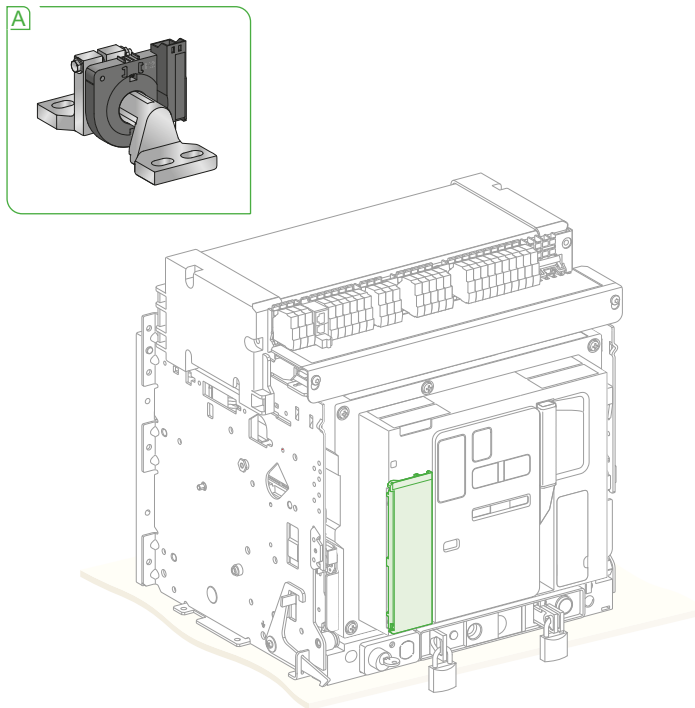

A TCE - external sensor for neutral and residual ground fault protection

Customize your Circuit Breaker with Accessories

Protection of people and property

Circuit protection

TCE external sensor for neutral and residual ground fault protection

Installed on the neutral conductor, the external sensor enables the circuit breaker to perform:

- Neutral protection for 3P only
- Neutral current measurement
- Ground fault protection for 3P circuit breakers in TNS System.

The rating of the sensor (CT) must be compatible with the rating of the circuit breaker:

- MTZ1 06 to MTZ1 16: TC 400/1600
- MTZ2 08 to MTZ2 20: TC 400/2000
- MTZ2 25 to MTZ2 40: TC 1000/4000
- MTZ3 40 to MTZ3 63: TC 4000/6300.

For MTZ1 or MTZ2, a single sensor with a single wire is provided.

For MTZ3, both a single sensor with a single wire and a double sensor with a double wire are available.

For oversized neutral protection, the sensor rating must be compatible with the measurement range: $1.6 \times I_n$ (available up to MTZ2 40 for MTZ2 and MTZ1 16 for MTZ1).



External sensor for neutral and residual ground fault protection (TCE)

LV83376SP_image.eps

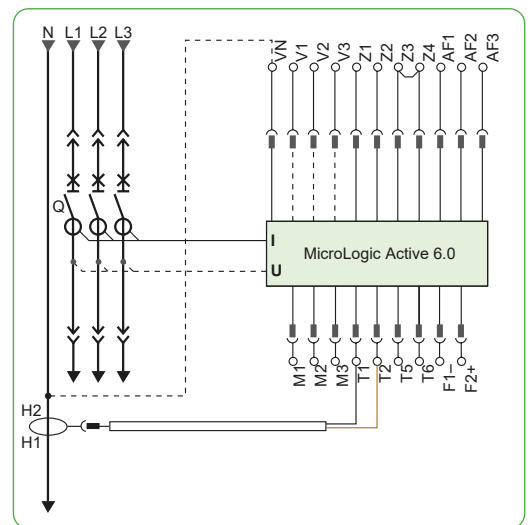

DB445386.aii

Customize your Circuit Breaker with Accessories

Protection of people and property

Operational and mechanical protection

Operational protection

Adding safety check points and reducing the safety risk during daily operation to the minimum level is a primary concern. The following accessories add protection, especially when physical contact with the circuit breaker is required.

Mechanical protection

In addition to the protection using electrical components, these accessories use simple mechanisms to provide enhanced protection for both people and property.

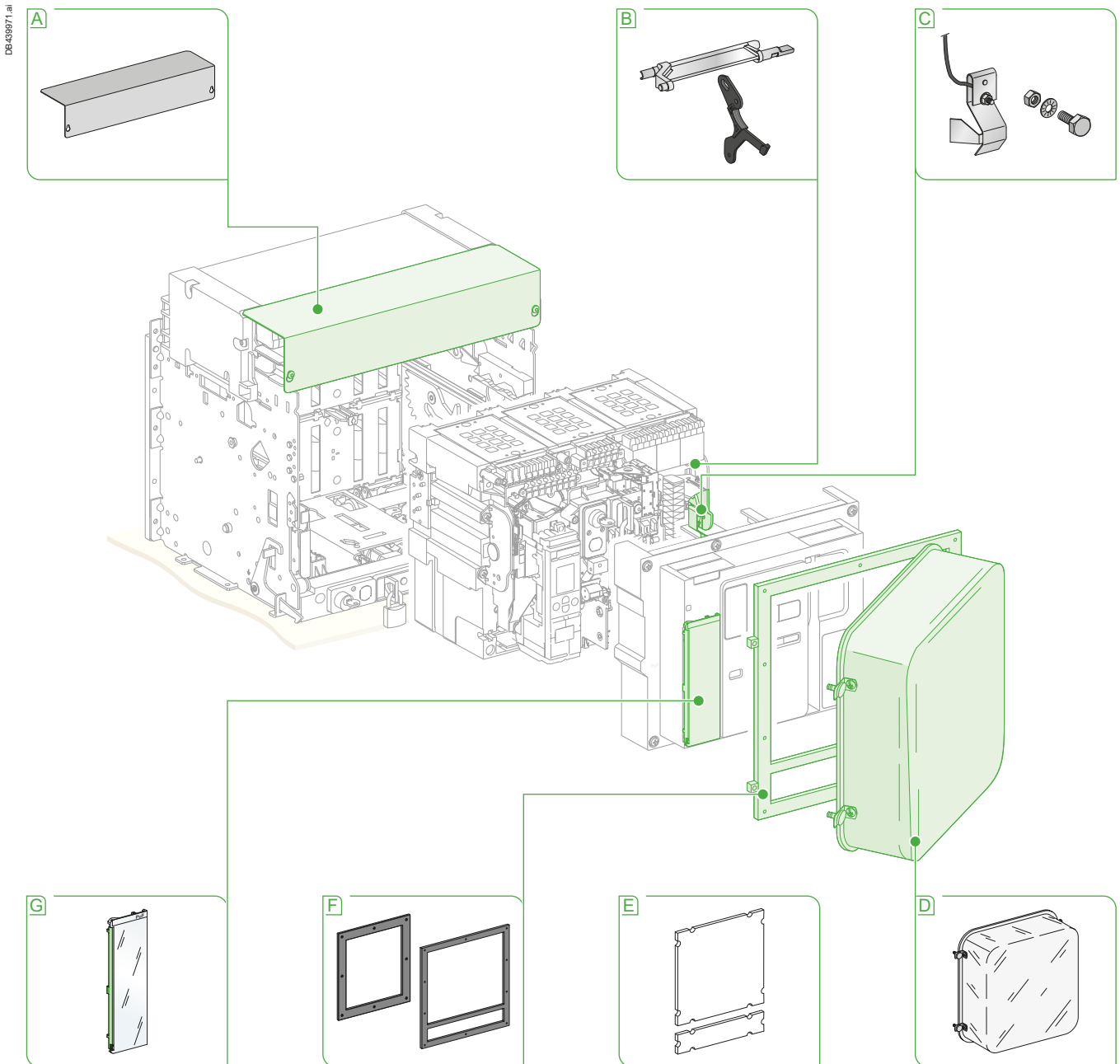

Operational protection

- A** CB - terminal block shield
- B** DAE - automatic spring discharge before breaker removal
- C** KMT - grounding kit

Mechanical protection

- D** CCP - transparent cover for escutcheon
- E** OP - blanking plate for escutcheon

- F** CDP - escutcheon
- G** Transparent cover for MicroLogic Active

Customize your Circuit Breaker with Accessories

Protection of people and property Operational and mechanical protection

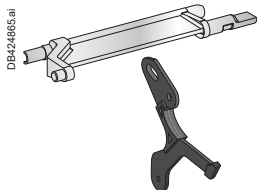

Automatic spring discharge DAE

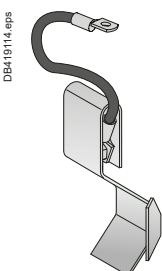

Grounding kit KMT

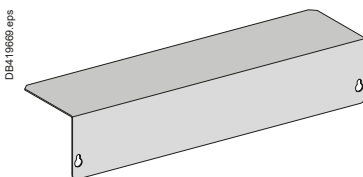

CB terminal block shield

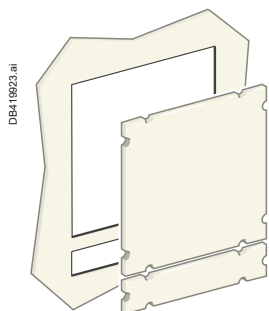

Blanking plate OP for escutcheon

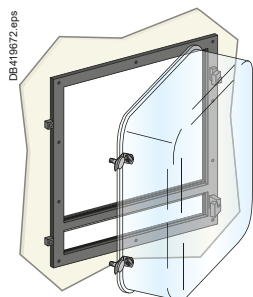

Transparent cover CCP for escutcheon.

Automatic spring discharge before breaker removal DAE (for MTZ2, MTZ3 only)

This option automatically discharges the spring before the circuit breaker is removed from the chassis.

Grounding kit KMT

This option enables the grounding of the circuit breaker mechanism while the front cover is removed. Grounding is achieved via the chassis for the drawout version and via the fixation side plate for the fixed version.

CB terminal block shield

This optional shield mounted on the chassis prevents access to the terminal block of the electrical auxiliaries.

Blanking plate OP for escutcheon

Used with the escutcheon, this option blocks off the door cut-out of a cubicle not yet equipped with a device. It may be used with the escutcheon for both fixed and drawout devices.

Transparent cover CCP for escutcheon

This optional cover mounted on the escutcheon is hinged and secured by a screw. It increases the degree of protection to IP54, IK10. It is only compatible with drawout devices.

Customize your Circuit Breaker with Accessories

Protection of people and property

Operational and mechanical protection

Door cut-out and escutcheon CDP

This optional escutcheon mounted on the door of the cubicle increases the degree of protection to IP40 (free-standing circuit breaker: IP30). It is available in fixed and drawout versions.

C

Door cut-out (see chapter F for more information)

MTZ1		MTZ2/MTZ3	
Fixed	Drawout	Fixed	Drawout
With or without escutcheon	Without escutcheon	With or without escutcheon	Without escutcheon
	With escutcheon		With escutcheon

Escutcheon (see chapter F for more information)

MTZ1		MTZ2/MTZ3	
Fixed	Drawout	Fixed	Drawout

Power availability and reliability

Power supplies

Power availability and reliability is crucial in all situations. These accessories offer different ways of powering up the MicroLogic Active.

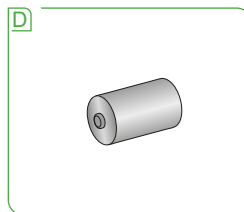
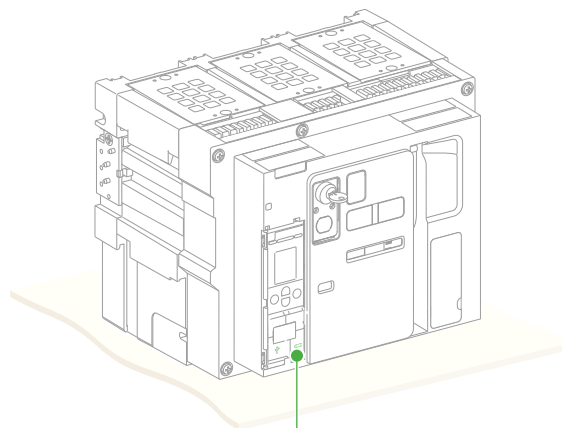
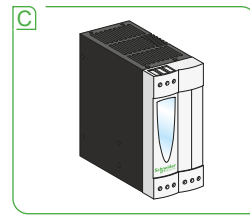
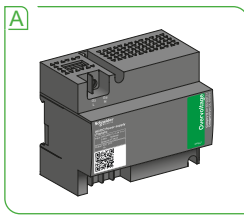

- A** External 24 V DC MicroLogic power supply
- B** Power Pack for MicroLogic Active
- C** ABL8 24 V DC power supply
- D** Spare internal battery

MicroLogic Active power supplies

- The basic functions of protection performed by the MicroLogic Active (LSIG: Long-time overload protection, Short-time short circuit protection, Instantaneous short circuit protection, Ground fault protection) do not require an external power supply. They are self-powered by the currents delivered by the current transformers embedded in the MTZ circuit breaker.
- When the circuit breaker load current is above 20 % of the rated current, the proper operation of all the functions performed by the MicroLogic Active is ensured. This includes:
 - The protection functions
 - All the measurements with the level of accuracy specified on [page B-20](#) of this catalog
 - The diagnosis
 - The HMI (embedded display and key pad)
 - The wireless features (Zigbee).
- When the load current falls below 20 % of the rated current, an external 24 V DC power supply is needed to maintain the operation of MicroLogic Active with its specified performance.
- For wireless option, it is recommended to use a 24V external power supply.
- The external 24 V DC is compulsory to supply power to the following devices and functions associated with the MicroLogic Active:
 - EIFE module
 - IFE module
 - IFM module
 - ERMS switch module
 - FDM121/128

Two types of 24 V DC power supply are offered to supply power to the MicroLogic Active and its associated modules:

- The 24 V DC MicroLogic power supply
- The 24 V DC Universal Phaseo ABL8 RPS 24050 and ABL8 RPS 24030 power supply.

In addition, a portable Power Pack battery can be used to supply power to the MicroLogic Active through its USB-C port.

Customize your Circuit Breaker with Accessories

Power availability and reliability

Power supplies

External 24 V DC MicroLogic power supply

The external power-supply module makes it possible:

- To use the display even if the circuit breaker is open or does not have a power supply (for the exact conditions of use, see the *Electrical Diagrams* part of this catalog)
- To display fault currents after tripping
- To modify settings when the circuit breaker is open (OFF position)

An external 24 V DC power supply is required for installation with communication, whatever the type of control unit, for MicroLogic with additional protection or advanced features.

This module is not designed to power on 24 V DC voltage releases or electric motor mechanism.

This module powers the control unit.

Characteristics

- Power supply AC-to-DC or DC-to-DC
- Output voltage: 24 V DC $\pm 5\%$.
- Output current: 1 A.
- DIN rail or plate mounting with Acti9 form factor
- Conducted emissions power line: class B per EN/IEC 61000-6-3.



External 24 V DC MicroLogic power supply

LV45444.eps

C

Customize your Circuit Breaker with Accessories

Power availability and reliability

Power supplies

PF-1063496E_ABL8RPS24050.eps



ABL8 RPS power supply

24 V DC Universal Phaseo™ ABL8 power supplies

The Universal Phaseo ABL8 RPS 24050 and ABL8 RPS 24030 power supplies can be connected phase-to-neutral or phase-to-phase.

They deliver a voltage that is accurate to 3 %, whatever the load and whatever the value of the AC supply, within the ranges 85 to 132 V AC and 170 to 550 V AC.

The Universal Phaseo ABL8 powers:

- Circuit breaker communication module and interface
- Programmable MicroLogic.

Characteristics

- Power supply: AC-to-DC.
- Network frequency: 50/60 Hz (±5 %).
- Output voltage: 24 V DC ±3%.
- Output current: 3 or 5 A.
- DIN rail or plate mounting.
- Conducted emissions power line: class B per EN/IEC 61000-6-3.

To assist cooling, there must be sufficient clearance around the Universal Phaseo power supplies range:

- 50 mm above and below
- 10 mm on the side.

		ABL8RPS●●●●	Module AD
Overvoltage Category		Cat I per VDE 0106-1	Cat IV per IEC 62477-1 (AC model) Cat III per IEC 62477-1 (DC model) Cat III per UL 61010-1
Degree of pollution as per IEC 60664-1		2	3
Input supply voltage AC		100...120 V AC and 200...500 V AC	110-130 or 200-240 V AC
Input supply voltage DC		N/A	24-30 or 48-60 or 100-125 V DC
Dielectric	Input/Output	4 kV rms - 1 mn.	3 kV rms - 1 mn. (110-130 V AC and 200-240 V AC model) 3 kV rms - 1 mn. (110-125 V DC model) 2 kV rms - 1 mn. (24-30 V DC and 48-60 V DC model)
	Input/Ground	3.5 kV rms - 1 mn.	3 kV rms - 1 mn.
	Output /Ground	0,5 kV rms - 1 mn.	1.5 kV rms - 1 mn.
Temperature		<ul style="list-style-type: none"> ■ 50 °C ■ 60 °C with 80 % of the rated current maximum 	70°C
Output current		3 A (ABL8RPS24030) 5 A (ABL8RPS24050)	1 A
Inrush current for 2 ms		< 30 A	< 20 A
Ripple		200 mV peak-peak	200 mV peak-peak
Output voltage limits		24 to 28.8 V DC	22.8 to 25.2 V DC
Protection degree		IP20	IP4x front face / IP2x terminals / IP3x other

Note: For the applications requiring an over voltage category higher than 1, a surge arrester shall be associated to ABL8 RPS power supplies. The iQuickPRD20 type 2 surge arrester is recommended.



Power availability and reliability

Power supplies

Mobile Power Pack for MicroLogic Active

The mobile portable Power Pack battery is a manufactured & tested Schneider Electric device that can energize the MicroLogic Active through its mini USB port.

It allows to use the embedded display & keypad for basic settings & reading or access to complementary tripping information during shutdown.

Mobile Power Pack can be easily recharged by connecting it to a PC or a charger equipped with a USB port.

The Remaining power available in Power Pack can be read when pressing the power button for 1 second.

The Power Pack can also be used to charge a smartphone (a USB cable with a mini USB port is provided for this purpose).

This item can be ordered as a spare part.



Mobile Power Pack for MicroLogic Active

PB115866_60.eps

Status Indicators

Battery capacity display	State explanation
	100 %
	70 %
	40 %
	15 %
	< 15 %
	0 %
	Battery charging in progress
	Internal fault

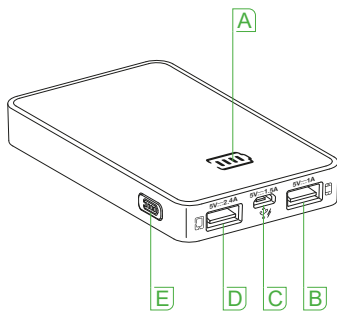

- A** Battery capacity display
- B** USB 5 V / 1 A output
- C** Micro-USB 5 V / 1.5 A input
- D** USB 5 V / 2.4 A output
- E** Power button

Spare internal battery

The MicroLogic Active control unit is equipped with an internal battery dedicated to the supply of the trip causes LEDs and the internal clock. The battery can be replaced on site when discharged.

The battery is lithium type.

A test button on the front of the control unit is used to check the battery condition.

This item can be ordered as a spare part.

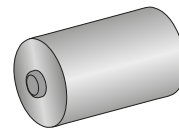

Spare internal battery

DB421457.ai

Integrate in Smart Panels - Architecture and Systems

Architecture overview.....D-3

Components

ULP Port..... D-14

EIFE embedded Ethernet interface..... D-16

IFE Ethernet interface D-18

IFE switchboard server..... D-20

IFM Modbus interface..... D-22

FDM121 Display Unit D-24

FDM128 Display Unit D-26

Customer engineering tool:

EcoStruxure Power Commission software..... D-28



Other chapters

- "Select a Circuit Breaker", page A-1
- "Select a MicroLogic Active Control Unit", page B-1
- "Customize your Circuit Breaker with Accessories", page C-1
- "Integrate in a Switchboard", page E-1
- "Integrate in Special Applications Source-Changeover Systems", page F-1
- "Services", page G-1
- "Order your Circuit Breaker", page H-1

Connect the Panel for



Sustainability

- Energy efficiency is a part of sustainability. If you do not know what is going on in your panel you cannot do anything to optimize the energy usage. That is why metering is necessary. And a lower energy bill helps both the environment and lower energy cost.
- Minimize CO₂ footprint.

Safety

Prevent injuries to people and damage to equipment. By monitoring temperature, humidity and gases in the panel, the likelihood of accidents, such as fire, decreases.

Power Availability

Prevent unexpected downtime through better monitoring and connectivity.

Business and Operation Continuity

Ensuring resilience through source management.

MasterPacT MTZ with MicroLogic Active

Enerlin'X enables the integration of MasterPacT MTZ in a digital system and enables the integration in EcoStruxure Software solutions. Enerlin'X can also be used for connecting with a local display.

- > For MasterPacT MTZ drawout circuit breaker, Enerlin'X EIFE is used for Ethernet connectivity
- > For MasterPacT MTZ fixed circuit breaker, Enerlin'X IFE is used for Ethernet connectivity

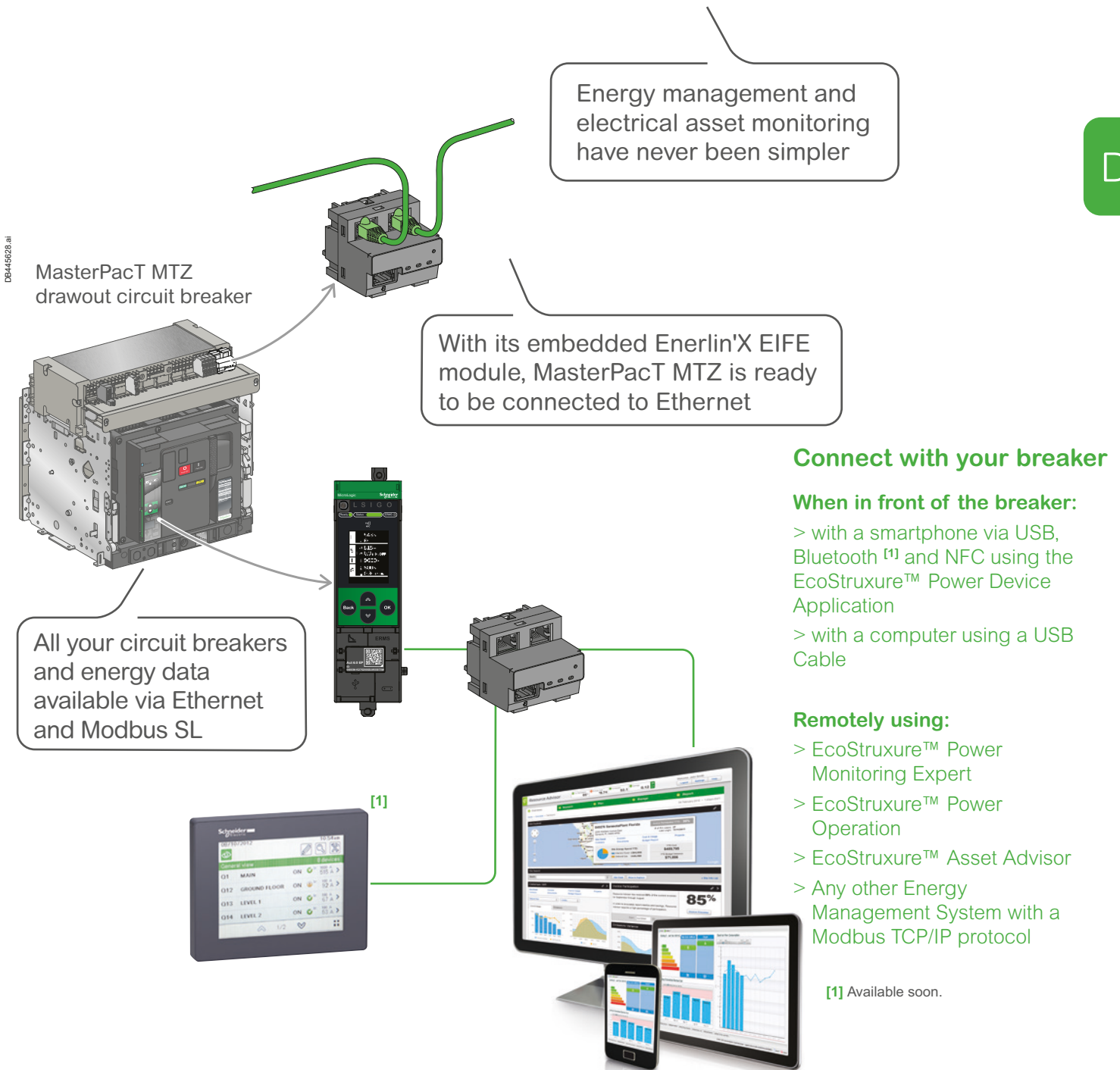

Connect with your breaker

When in front of the breaker:

- > with a smartphone via USB, Bluetooth [1] and NFC using the EcoStruxure™ Power Device Application
- > with a computer using a USB Cable

Remotely using:

- > EcoStruxure™ Power Monitoring Expert
- > EcoStruxure™ Power Operation
- > EcoStruxure™ Asset Advisor
- > Any other Energy Management System with a Modbus TCP/IP protocol

[1] Available soon.

Architecture overview

D

General architecture

MicroLogic Active control units with their interfaces offer the following communication channels:

- Connection to an Ethernet network through either an EIFE or IFE interface module. The EIFE and IFE modules are connected to the MicroLogic Active control unit by means of a ULP port and a prefabricated ULP cord. The EIFE is specific to drawout circuit breakers. The IFE is specific to fixed circuit breakers.
- Connection to a Modbus SL RS 485 bus through an IFM interface module. The IFM module is connected to the MicroLogic Active control unit by means of a ULP port and a prefabricated ULP cord
- Communication with a smartphone via USB or a wireless powerless NFC channel.
- Communication with a PC via a USB port.
- Connection to the Internet, which is possible through a Panel Server module connected to an internal Ethernet network or Wi-Fi.

In addition, MicroLogic Active control units offer a wireless interface for communication with a Panel Server module.

The EIFE is designed to monitor the three positions of the circuit breaker when inserted in its chassis:

- Circuit breaker racked IN (CE contact),
- Circuit breaker racked OUT (CD contact),
- Circuit breaker in test position (CT contact),
- No additional I/O module is required to monitor these three positions.

The connection of an FDM128 display ^[1] unit to the Ethernet internal bus or a FDM121 to a ULP port is possible for any configuration.

The following control orders, information and data are made available on Ethernet and Modbus SL:

- Events:
 - All the events logged in the event histories of MicroLogic Active
- Status indications:
 - ON/OFF (O/F)
 - Spring charged (CH)
 - Ready to close
 - Fault trip (SDE)
 - Connected / disconnected / test position (CE/CD/CT)
- Measurements
 - Instantaneous measurement information
 - Averaged measurement information
 - Maximeter / minimeter
 - Energy metering
 - Power quality
- Operating assistance:
 - Protection settings and alarm
 - Histories
 - Maintenance indicators
- Availability:
 - Access control by password as in the existing offer. To be initialized by the user.

[1] Available soon.

IEEE-based

Drawout and fixed circuit breaker

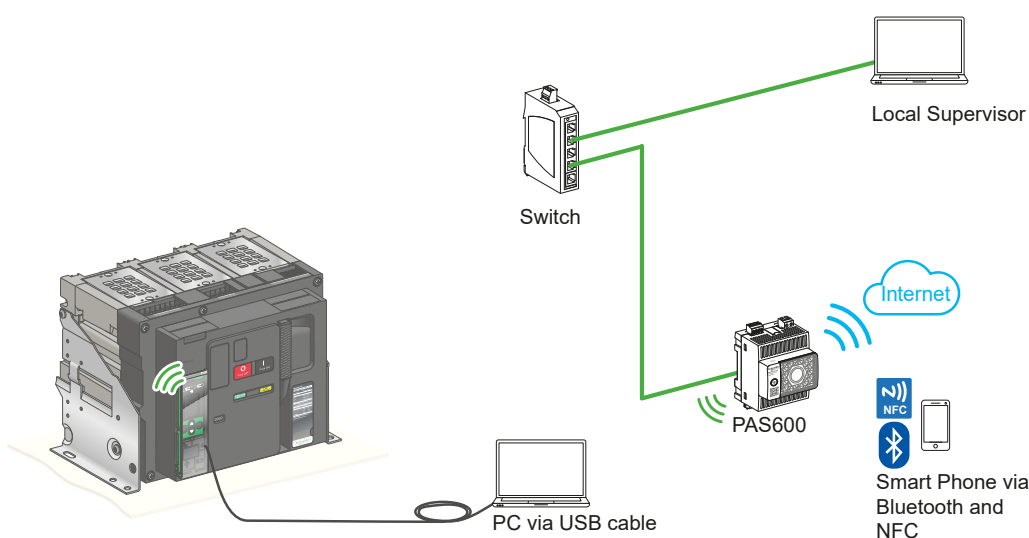
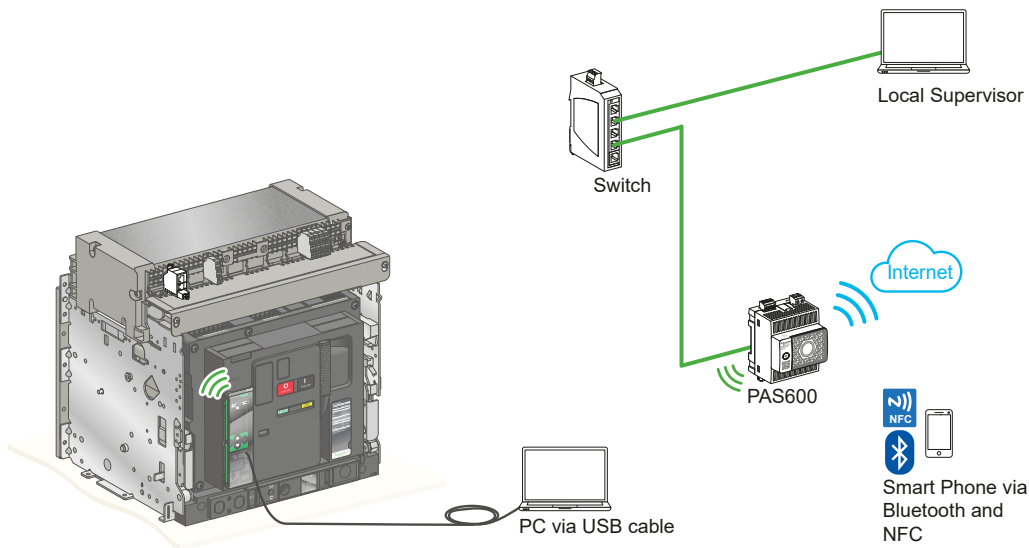

- Ethernet
- ULP
- Modbus SL
-))) Wi-Fi
-))) Zigbee

Note: Connected solutions including local Bluetooth not available yet.



Ethernet-based

Drawout and fixed circuit breaker

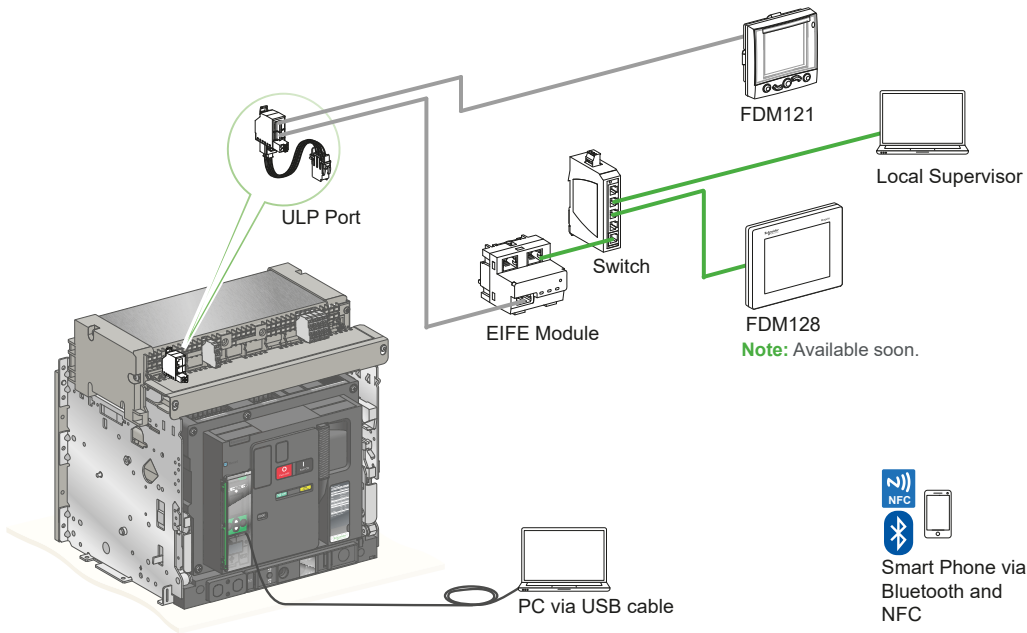

DB446690.ai

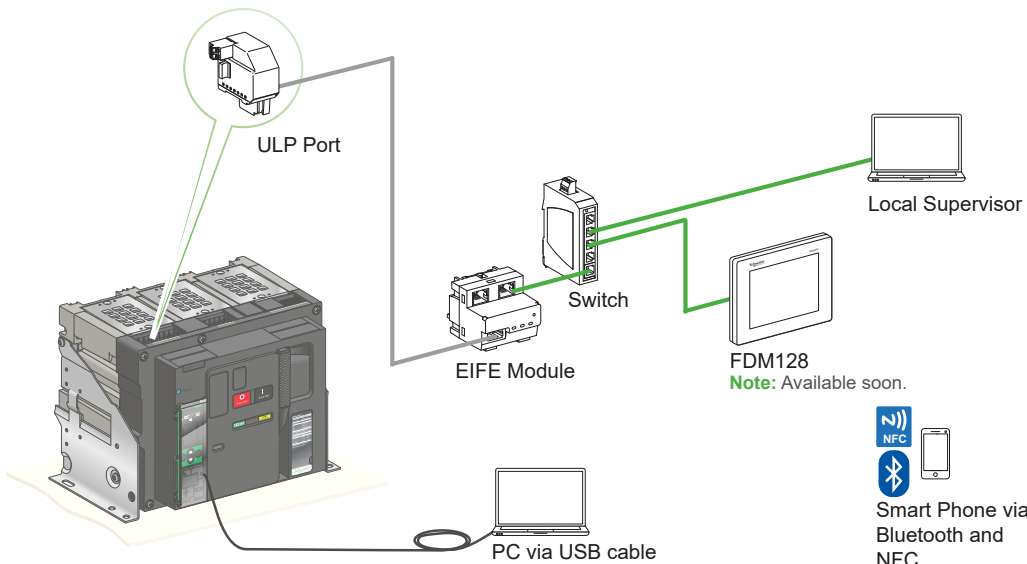

DB446681.ai

- Ethernet
- ULP
- Modbus SL
-))) Wi-Fi
-))) Zigbee

Note: Connected solutions including local Bluetooth not available yet.

Modbus SL-based Drawout and fixed circuit breaker

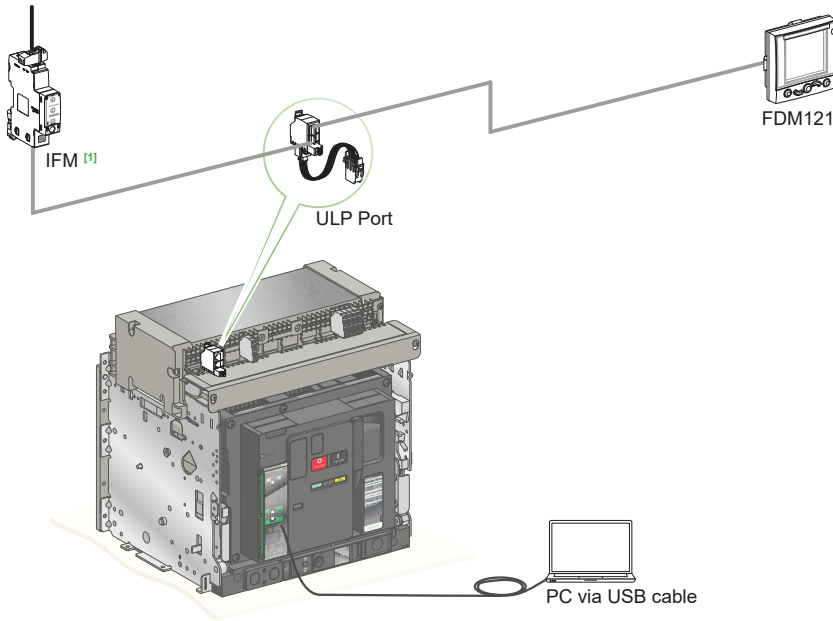

DB446692.ai







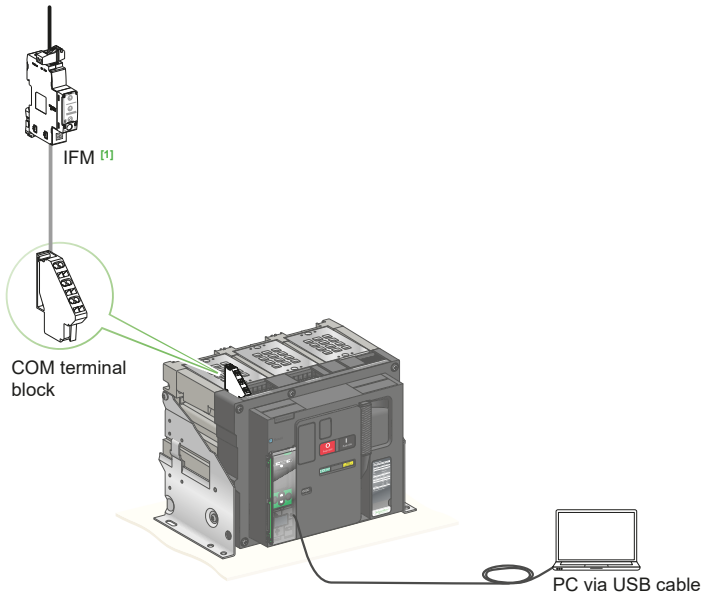



 Smart Phone via
 Bluetooth and
 NFC



DB446693.ai





 Smart Phone via
 Bluetooth and
 NFC

-  Ethernet
-  ULP
-  Modbus SL
-  Wi-Fi
-  Zigbee

[1] Connection to a Modbus network through an IFM interface.

Note: Connected solutions including local Bluetooth not available yet.

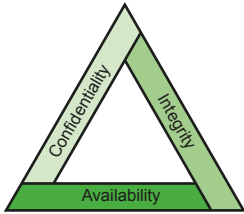
DB415762.ai



Confidentiality

- Bluetooth Smart: Wireless Encrypted (AES-128) communication (IEEE 802.15.1)
- NFC: operates in very short range (few centimeters)
- Compliant with NIST 800-121 concerning pairing method and encryption.

Integrity

- Only Schneider Electric firmwares can be installed in the MicroLogic Active control unit.

Availability

- Access control managed by password. To be initialized by the user to change the default values.
- Restricted USB usage for communication profile only (no mass storage).

System security

Operational security is an important concern for electrical installations when it comes to both local and remote interaction. Confidentiality, integrity and availability (also known as the AIC triangle) is a model designed to guide policies for information security within an organization and these elements are considered to be the three crucial components of security.

In this context, confidentiality is a set of rules that limits access information (equivalent to privacy), integrity is the assurance that the information is trustworthy and accurate, and availability is a guarantee of reliable access to the information by authorized people.

Bluetooth Smart connectivity

MicroLogic Active control units are equipped (as standard) with Bluetooth 4.0 Smart wireless communication which establishes a connection with a smartphone equipped with the same technology. Bluetooth Smart complies with the IEEE 802.15.1 standard ^[1].

Proprietary connectivity

MicroLogic Active control unit are natively equipped with proprietary Zigbee connectivity which enables a connection with panel server.

NFC connectivity

MicroLogic Active control units are equipped with near-field communication (NFC) capability which enables data exchange with a smartphone equipped with the same technology in accordance with the standard ISO/IEC 15693-3.

[1] Available soon.

ULP connectivity

ULP is a fast communication link dedicated to circuit breaker monitoring and control. It connects the circuit breaker to an Ethernet interface, Modbus interface and/or local display. ULP operates at a speed of 1 Mb/s and is plug & play.

Ethernet connectivity

Ethernet is a data link and physical layer protocol complying with the IEEE 802.3 standard. It operates at a speed of 10, 100 or 1000 Mbps. The maximum length of Ethernet cable between two devices is 100 meters.

IFE and EIFE Ethernet interfaces can be connected to a PC, a laptop or a PLC over Ethernet. IFE Ethernet switchboard server provides a Modbus TCP/IP gateway over Ethernet to enable Modbus TCP communication from a Modbus TCP client to any Modbus server devices connected to it. The maximum active Modbus TCP client connection is twelve.

IFE and EIFE Ethernet interfaces have an embedded web server (web page).

Modbus connectivity

Modbus SL is a communication protocol widely used in industrial networks.

It operates according to a "client-server" mode. The servers communicate one at a time with the client. This is an RS 485 open bus on which communicating Modbus devices are connected. All types of PLCs and microcomputers may be connected on to the bus.

The maximum number of devices that may be connected to a bus depends on the type of devices, the baud rate (19,200 is recommended), the volume of data exchanged, and the expected response time. The RS 485 physical layer offers up to 32 connection points on the bus (1 client, 31 servers). The maximum recommended length for the Modbus SL bus is 1,200 meters.

Digital Switchboard Example Architecture

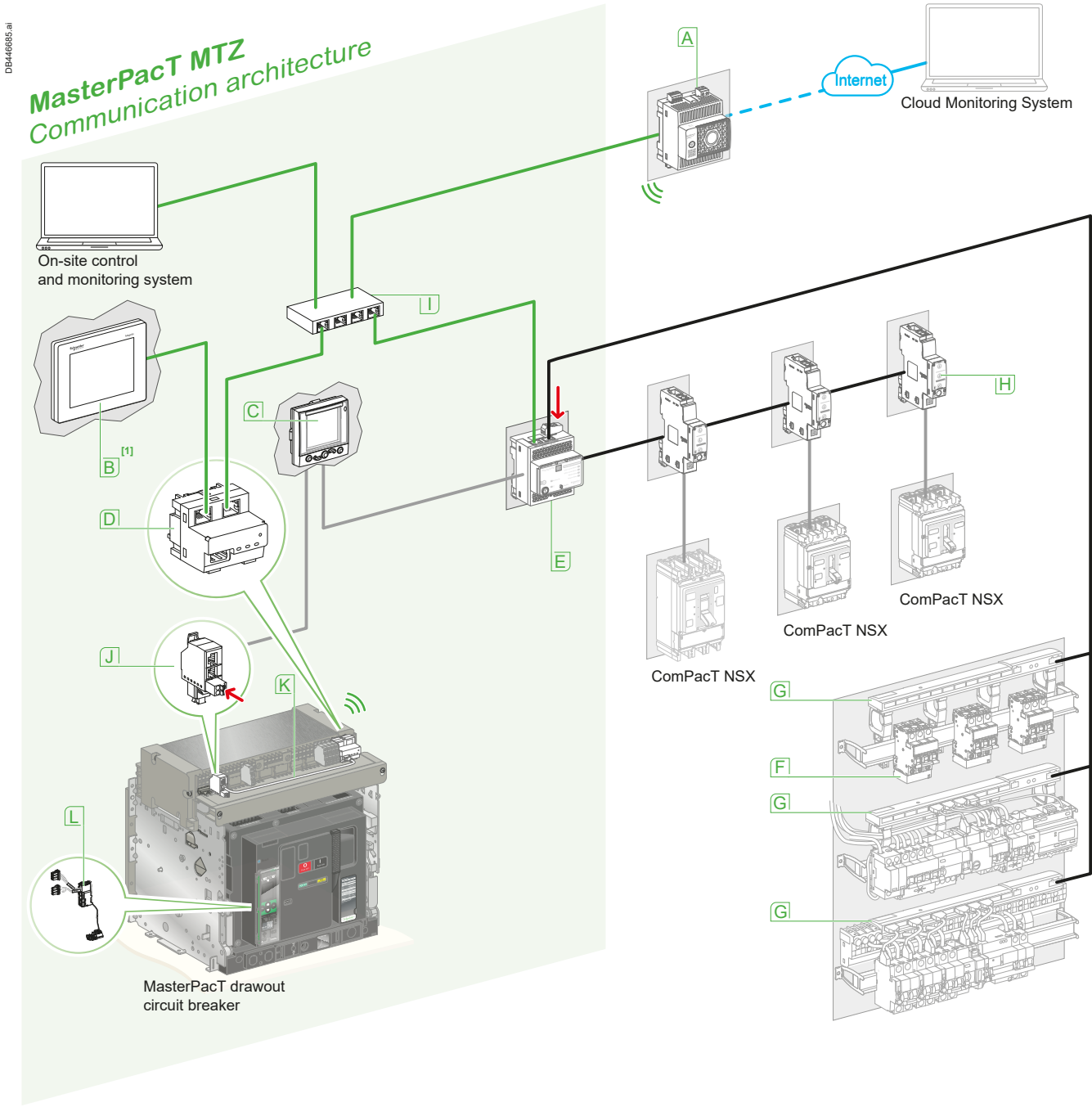

D







ULP is a communication link dedicated to circuit breaker monitoring and control

- 24 V DC
- Ethernet
- Modbus SL
- ULP
-))) Wi-Fi
-))) Zigbee

- A** Panel Server (PAS600)
- B** FDM128 ^[1]
- C** FDM121
- D** EIFE
- E** IFE
- F** PowerTag Energy with radio frequency communication
- G** I/O Smart Link
- H** IFM
- I** Switch
- J** ULP port
- K** ULP cord
- L** BCIM

Note: For every MasterPacT MTZ, all the associated interface modules (ULP port, IFE, IFM, I/O) must have the same 24 V DC power supply.
[1] Available soon.

Enerlin'X digital devices for MasterPacT connection and monitoring

	Name	Function	Protocol		Bin. Input	Analog. Input	Bin. Output	Commercial Reference
			(to device)	(to server)				
A 	Panel Server	Gateway	IEEE802.15.4	Modbus TCP/IP or Wi-Fi	-	-	-	PAS400
			Modbus SL, Modbus TCP/IP or IEEE802.15.4	Modbus TCP/IP or Wi-Fi	2 (PAS600L only)			PAS600L, PAS600
		Gateway and data logging	Modbus SL, Modbus TCP/IP or IEEE802.15.4	Modbus TCP/IP or Wi-Fi	2 (PAS800L only)	-	-	PAS800L, PAS800, PAS800P
B 	FDM128	Ethernet LCD color touch display	Modbus TCP/IP	-	-	-	-	LV434128
C 	FDM121	Ethernet LCD color touch display	ULP	-	-	-	-	TRV00121
D 	EIFE	Embedded Ethernet interface ^[2]	ULP	Modbus TCP/IP	-	-	-	LV851001
E 	IFE switchboard server	Ethernet interface ^[2] & Gateway	ULP, Modbus SL or TCP/IP	Modbus TCP/IP	-	-	-	LV434002
	IFE interface	Ethernet interface for circuit breakers	ULP	Modbus TCP/IP	-	-	-	LV434001
I 	IFM interface	Modbus interface for circuit breakers	ULP	Modbus SL	-	-	-	LV434000

Ethernet Gateway or Interface: routes the internal traffic (ULP or other protocols) to the Internet: the outgoing messages are coded with Modbus TCP/IP protocol.

Server (Switchboard, Energy): routes the internal traffic to the Internet. Includes complementary functions such as data logging and storage. Provides device status and energy trends via internal web pages.

Note: For more information, see *ULP System for MasterPacT and ComPacT (IEC Standard) - User Guide* [DOCA0093EN](#) and *EcoStruxure Power for Commercial & Industrial Buildings - Smart Panels Assembly Guide* [ESXP1G003EN](#).

DE446885.ai

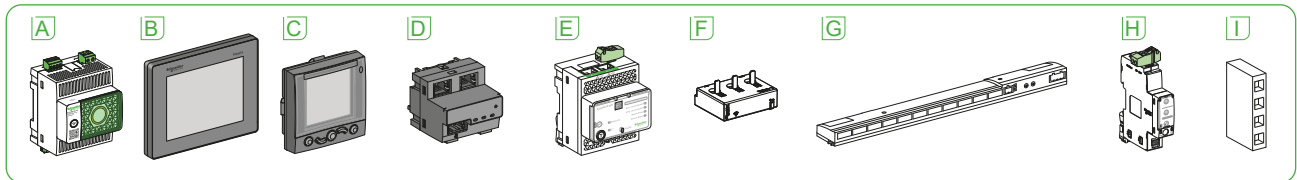
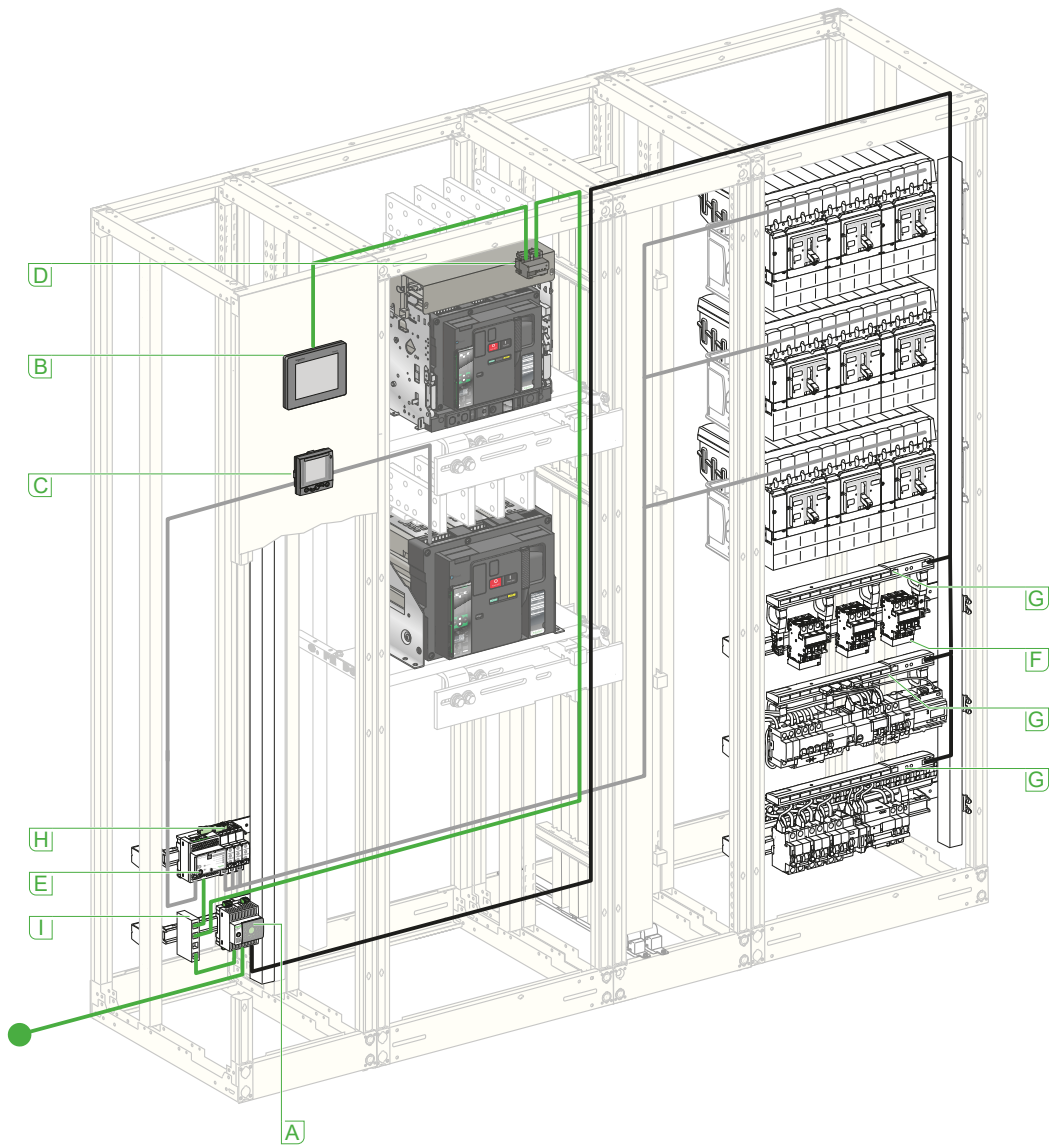

- Ethernet
- Modbus SL
- ULP

- A Panel Server (PAS600)
- B FDM128
- C FDM121
- D EIFE
- E IFE

- F PowerTag Energy with radio frequency communication
- G I/O Smart Link
- H IFM
- I Switch

- | | |
|--|--|
| Breaker ULP cord: | ULP cable: |
| ■ 0.3 m | ■ 0.3 m |
| ■ 1.3 m | ■ 0.6 m |
| ■ 3 m | ■ 1 m |
| ■ 5 m | ■ 3 m |
| | ■ 5 m |

Communication architecture

MTZ fixed circuit breaker

with breaker ULP cord

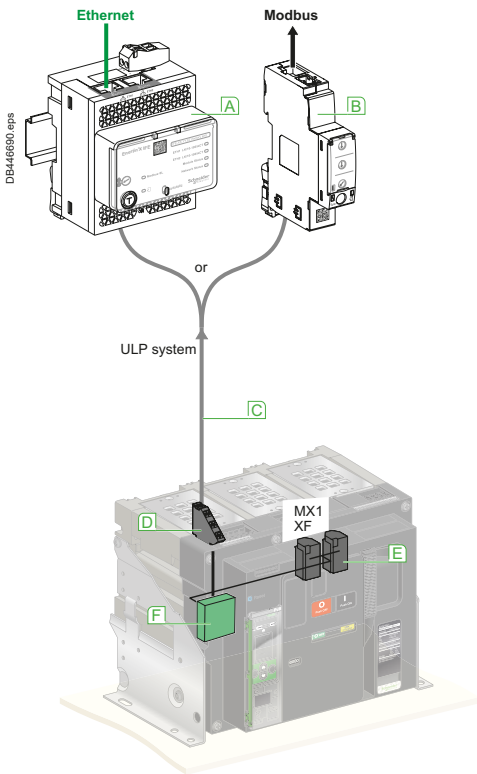

with ULP cable

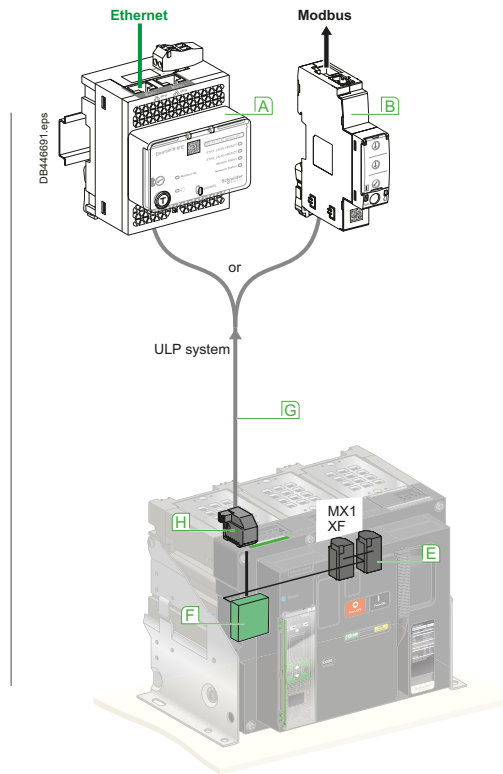

- A** IFM interface
- B** IFM interface
- C** Breaker ULP cord
- D** COM terminal block
- E** MX1 and XF communicating voltage releases
- F** BCIM module
- G** ULP cable
- H** ULP port

Note: For every MasterPact MTZ, all the associated interface modules (ULP port, IFE, IFM) must have the same 24 V DC power supply.

ULP system

ULP system is a fast communication link dedicated to circuit breaker monitoring and control. It is well adapted to extreme environments. A choice of recommended cables with different lengths are provided for the connection of EIFE, IFE to a ULP port.

EIFE / IFE interfaces

EIFE/IFE interfaces provide an IP address to any circuit breaker fitted with a ULP port. The EIFE / IFE interfaces make all available data from the circuit breaker accessible from an Ethernet-compatible display (FDM121), a PC, or a Modbus TCP/IP client. EIFE / IFE interfaces generate their own web pages.

DB446807.ai

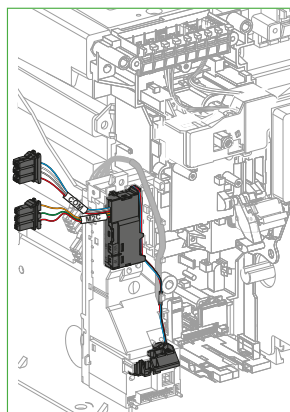
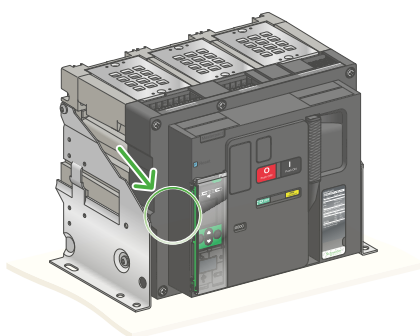

BCIM view

Communication architecture

MTZ drawout circuit breaker

with breaker ULP cord

with ULP cable

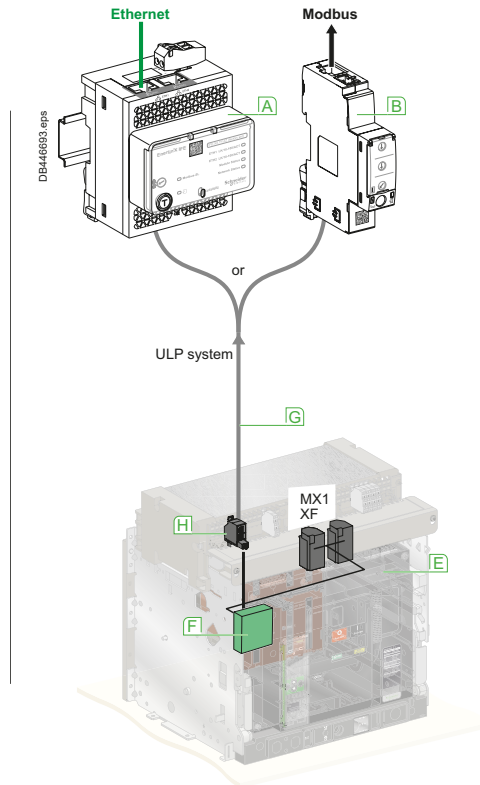
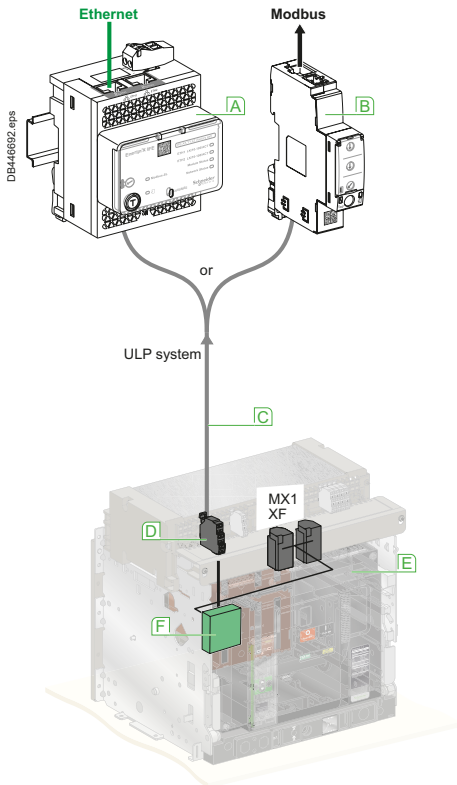

- A** IFM interface
- B** IFM interface
- C** Breaker ULP cord
- D** COM terminal block
- E** MX1 and XF communicating voltage releases
- F** BCIM module
- G** ULP cable
- H** ULP port

Note: For every MasterPact MTZ, all the associated interface modules (ULP port, IFE, IFM, I/O) must have the same 24 V DC power supply.

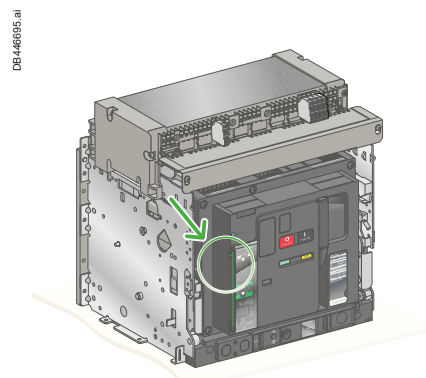
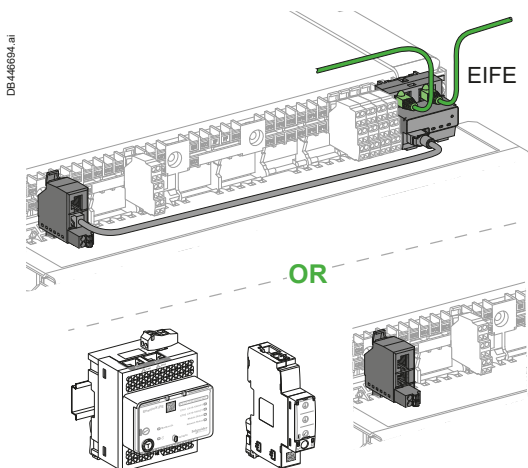

BCIM view

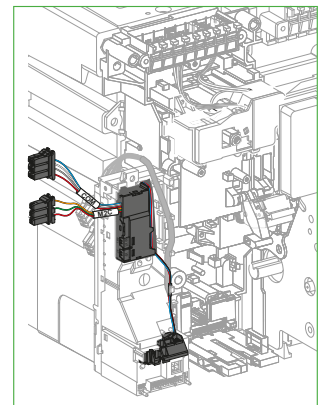

Components

ULP Port

In the new generation of MasterPacT MTZ circuit breakers, an internal communication protocol (BCIM) can be embedded in the MicroLogic Active control unit, as well as the microswitch contacts to obtain complementary circuit breaker status information (OF, SDE, PF, CH).

MasterPacT MTZ Fixed circuit breaker

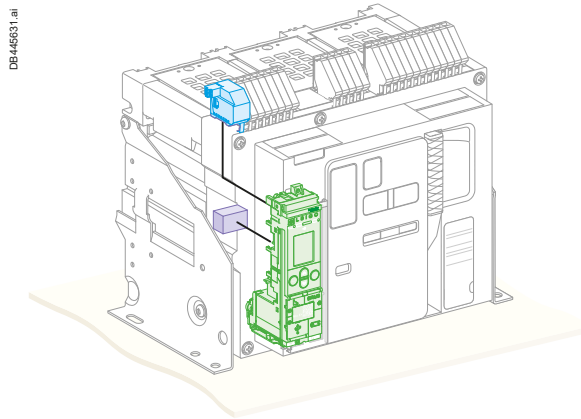

MasterPacT MTZ Drawout circuit breaker

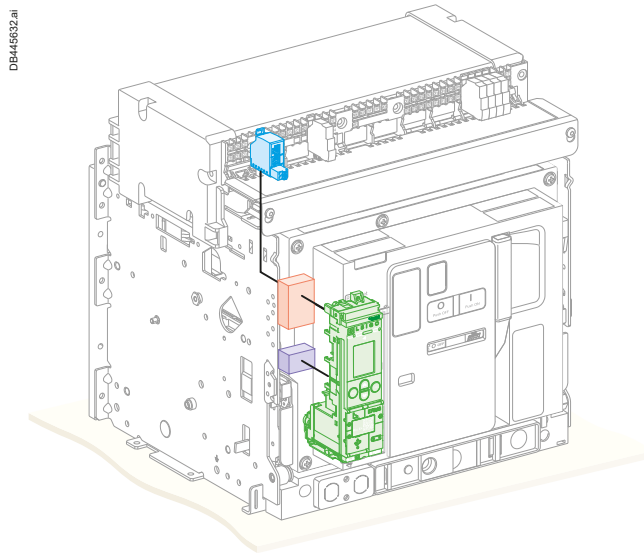

- MicroLogic Active
- ULP port
- Microswitch contact (OF, SDE, PF, CH)
- BCIM

Note: Reminder: MasterPacT MTZ Switch Disconnecter ranges (HA, NA) have no communication capabilities. They are not compatible with any communication architecture.

D

Components ULP Port

Depending on the type of the device (MasterPacT MTZ1, MTZ2, MTZ3, fixed or drawout version), the ULP port and its corresponding wiring kit is supplied as standard or as an option.

ULP port versions

MTZ1/2/3 fixed

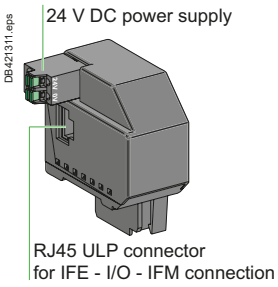

Optional

MTZ1 drawout

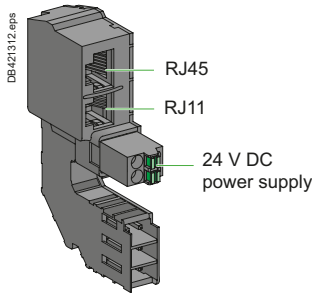

Optional

MTZ2/3 drawout

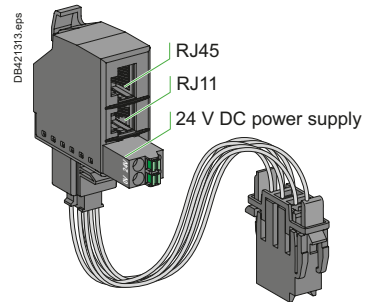

Standard

Notes:

- Standard ULP port (RJ45): used for connecting legacy devices (IO-IFE-IFM)
- EIFE port (RJ11): it is not possible to connect an EIFE and an IFM or an EIFE and an IFE at the same time

ULP port summary

The role of the ULP port is:

- To interconnect the MicroLogic Active with EIFE, IFE, IFM and I/O modules.
- To supply power to the control unit and the EIFE module.
- To integrate the ULP bus line termination.

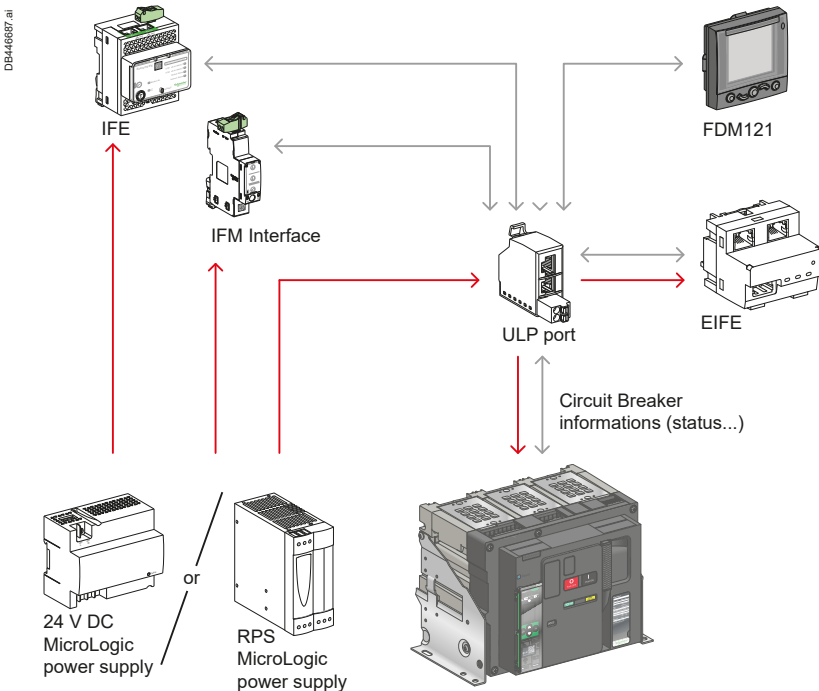

Note:

- When the ULP port is installed, the 24 V DC power supply must be disconnected from the terminals F1/F2 of the control unit.
- The connection of the +/- of the power supply either to terminals F1/F2 of the MicroLogic Active or to the +/- terminals of the ULP port must be strictly respected. Inverting the polarities may damage the device.
- For every MasterPacT MTZ, all the associated interface modules (ULP port, IFE, IFM) must have the same 24 V DC power supply.



Components

EIFE embedded Ethernet interface



EIFE embedded Ethernet interface

EIFE embedded Ethernet interface description

Introduction

The EIFE embedded Ethernet interface module enables drawout MasterPacT MTZ circuit breakers to be connected to an Ethernet network.

It provides digital access and it monitors the three positions of the circuit breaker when inserted in its chassis:

- Circuit breaker racked IN,
- Circuit breaker racked OUT,
- Circuit breaker in test position.

EIFE becomes then the best solution for switchboards demanding high uptime.

EIFE interface: ref. LV551001

Provides Ethernet access to a single drawout MasterPacT MTZ circuit breaker.

Function

One circuit breaker is connected to the EIFE interface via its ULP port.

EIFE interface features

- Dual 10/100 Mbps Ethernet port for simple daisy chain connection.
- Device profile web service for discovery of the EIFE interface on the LAN.
- Ethernet interface for drawout MasterPacT circuit breakers.
- Secure embedded set-up web pages over HTTPS.
- Secure embedded monitoring web pages over HTTPS.
- Secure embedded control web pages over HTTPS.
- Chassis status management (CE, CD, CT).
- Built-in e-mail alarm notification.
- RBAC (Role Base Access Control).
- RSTP (Rapid Spanning Tree Protocol) for implementing redundant Ethernet networks.
- NTP (network time protocol) for precise time synchronization.

Mounting

The EIFE interface is mounted on the chassis of the drawout circuit breaker.

There are two types of dedicated ULP cable, one for the MTZ1 and one for MTZ2/MTZ3.

24 V DC power supply

The EIFE power supply is provided by the ULP port through the dedicated ULP cable.

EIFE interface firmware update

The firmware can be updated using EcoStruxure Power Commission software.

Required circuit breaker communication accessory

The connection to the EIFE interface requires a ULP communication port on the chassis of the drawout MasterPacT MTZ circuit breakers.

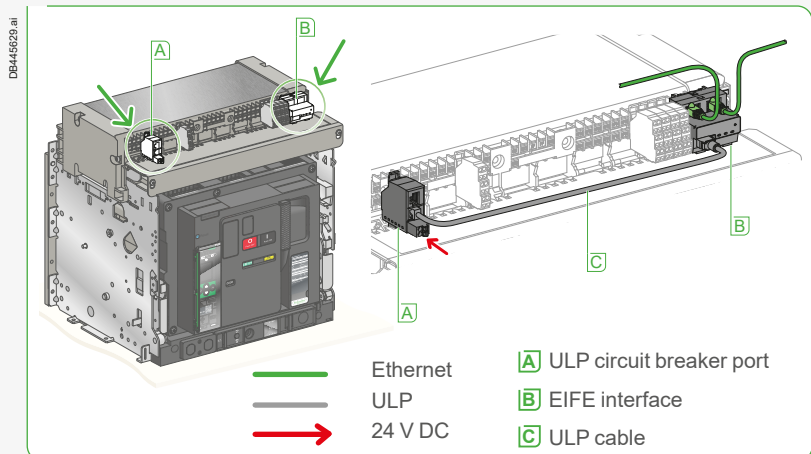

EIFE mounting and cabling



Components

EIFE embedded Ethernet interface

DB419373 eps



General characteristics	
Environmental characteristics	
Conforming to standards	IEC 60950, IEC 60947-6-2, UL 508, UL 60950, IACS E10
Certification	c UL us, CE, EAC, FCC marking
Ambient temperature	storage: -40 to +85 °C operation: -25 to +70 °C
Relative humidity	5 - 85 %
Level of pollution	Level 3
Protective treatment	ULV0 conforming to IEC/EN 60068-2-30
Mechanical characteristics	
Shock resistance	As the EIFE is mounted on the circuit breaker it complies with its mechanical characteristics
Resistance to sinusoidal vibrations	As the EIFE is mounted on the circuit breaker it complies with its mechanical characteristics
Electrical characteristics	
Consumption	100 mA at 24 V DC
Resistance to electrostatic discharge	IEC/EN 61000-4-2: ■ 8 kV air discharge ■ 6 kV contact discharge
Immunity to radiated fields	IEC/EN 61000-4-3: 20 V/m
Immunity to fast transient disturbances	IEC/EN 61000-4-4: 2 kV
Immunity to surges	IEC/EN 61000-4-5: 2 kV common mode
Immunity to conducted radio frequency field	IEC/EN 61000-4-6: 10 V
Physical characteristics	
Dimensions	51 x 51 x 52.5 mm
Mounting	Breaker DIN rail of MTZ1 & MTZ2/MTZ3
Weight	75 g EIFE alone
Degree of protection of the installed module	■ IP20 for connectors ■ IP30 for other areas
Connections	■ RJ45 for Ethernet ■ Industrial USB connector for ULP

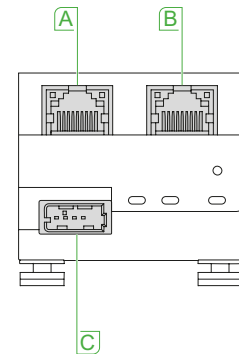

- A** Ethernet port 1
- B** Ethernet port 2
- C** ULP port

EIFE web page description

Monitoring and control web page:

- Real-time data
- Device logging.
- Single-device control

Diagnostics web page:

- EIFE communication status
- Ethernet and protocol statistics
- IMU information

Setup web page:

- Device localization/name
- Ethernet configuration (dual port)
- IP configuration
- Date and time

- E-mail server configuration
- Alarms to be e-mailed
- Device logging
- Device log export
- RSTP configuration
- SNMP parameters
- Preferences

Security web page:

- IP network settings
- Advanced services control
- Modbus TCP/IP filtering
- Certificate management
- User management

Components

IFE Ethernet interface

PB 119652.eps



IFE interface, ref.: LV434001

D

IFE interface server description

Introduction

The IFE interface enables LV circuit breakers to be connected to an Ethernet network. The IFE interface is equipped with two ULP ports and two Ethernet ports. The following circuit breakers can be connected to the IFE interface and to IFE switchboard server: Fixed type MasterPacT MTZ, ComPacT NSX or PowerPacT.

IFE interface: ref. LV434001

Provides an Ethernet access to a single LV circuit breaker. The circuit breaker is connected to the IFE interface via its ULP port and a prefabricated ULP cord ^[1].

IFE interface

- Dual 10/100 Mbps Ethernet port for simple daisy chain connection.
- Device profile web service for discovery of the IFE interface and IFE switchboard server on the LAN.
- ULP compliant for localization of the IFE interface in the switchboard.
- Ethernet interface for MasterPacT, ComPacT and PowerPacT circuit breakers.
- Support of Modbus TCP/IP communication protocol.
- Secure embedded set-up web pages over HTTP.
- Secure embedded monitoring web pages over HTTPS.
- Secure embedded control web pages over HTTPS.
- Built-in e-mail alarm notification.
- Internal real-time clock with battery back-up.
- RBAC (Role Base Access Control) for the embedded control web pages.
- RSTP (Rapid Spanning Tree Protocol) for implementing redundant Ethernet networks.
- NTP (network time protocol) for precise time synchronization.

Mounting

The IFE interface is mounted on a DIN rail.

24 V DC power supply

The IFE interface must have either a 24 V DC AD or a 24 V DC ABL8 RPS power supply.

Note: The connection of the +/- of the power supply to the +/- terminals of the IFE device must be strictly respected. Inverting the polarities may damage the device.

IFE interface firmware update

The firmware can be updated using the EcoStruxure Power Commission software.

Required circuit breaker communication modules

The connection to IFE interface or to IFE switchboard server requires ULP communication ports. Every MasterPacT MTZ, fixed type circuit breakers is equipped with a ULP port connected to its associated IFE Ethernet interface module by a prefabricated ULP cord. The IFE Ethernet interface modules are equipped with two ULP RJ45 connectors. When one is not used, it must be closed with a ULP terminator.

Components

IFE Ethernet interface

General characteristics	
Environmental characteristics	
Conforming to standards	IEC 60950, IEC 60947-6-2, UL 508, UL 60950, IACS E10
Certification	c UL us, CE, EAC, FCC marking
Ambient temperature	storage: -40 to +85 °C operation: -25 to +70 °C
Relative humidity	5 - 85 %
Level of pollution	Level 3
Protective treatment	ULV0 conforming to IEC/EN 60068-2-30
Mechanical characteristics	
Shock resistance	Conforming to IEC/EN 60068-2-27 15 g / 11 ms, 1/2 sinusoidal
Resistance to sinusoidal vibrations	Conforming to IEC/EN 60068-2-6 5 Hz < f < 8.4 Hz
Electrical characteristics	
Consumption	150 mA at 24 V DC
Resistance to electrostatic discharge	IEC/EN 61000-4-2: ■ 8 kV air discharge ■ 6 kV contact discharge
Immunity to radiated fields	IEC/EN 61000-4-3: 10 V/m
Immunity to fast transient disturbances	IEC/EN 61000-4-4: 2 kV
Immunity to surges	IEC/EN 61000-4-5: 2 kV common mode
Immunity to conducted radio frequency field	IEC/EN 61000-4-6: 10 V
Physical characteristics	
Dimensions	72 x 105 x 71 mm
Mounting	DIN rail
Weight	182.5 g (0.41 lb)
Degree of protection of the installed I/O	■ On the front panel (wall mounted enclosure): IP4x ■ Connectors: IP2x ■ Other parts: IP3x
Connections	Screw type terminal blocks

IFE web page description

Monitoring and control web page:

- Real-time data
- Device logging
- Single-device control

Diagnostics web page:

- EIFE communication status
- Ethernet and protocol statistics
- IMU information

Setup web page:

- Device localization/name
- Ethernet configuration (dual port)
- IP configuration
- Date and time
- E-mail server configuration
- Alarms to be e-mailed

- Device logging
- Device log export
- RSTP configuration
- SNMP parameters
- Preferences
- Advanced service control
- User accounts
- Web page access

Security web page:

- IP network settings
- Advanced services control
- Modbus TCP/IP filtering
- Certificate management
- User management

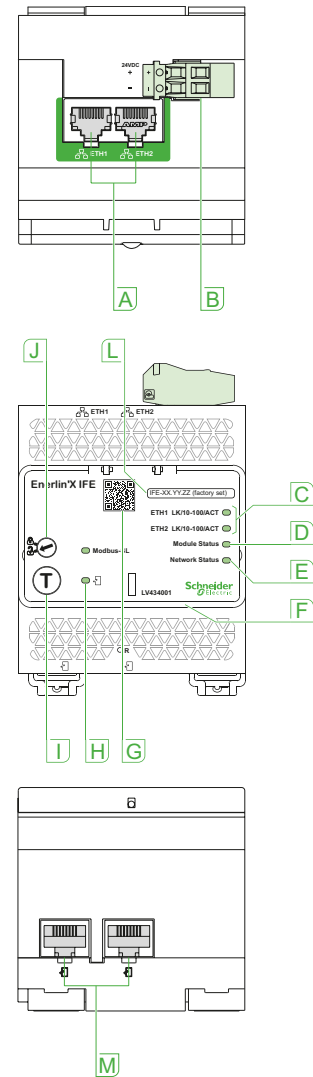

- A** Ethernet 1 and Ethernet 2 communication port.
- B** 24 V DC power supply terminal block.
- C** Ethernet communication LEDs:
yellow: 10 Mb
green: 100 Mb.
- D** Module status LED:
steady off: no power
steady green: device operational
steady red: major fault
flashing green: standby
flashing red: minor fault
flashing green/red: self-test.
- E** Network status LED:
steady off: no power/no valid IP address
steady green: connected, valid IP address
steady orange: default IP address
steady red: duplicated IP address
flashing green/red: self-test.
- F** Sealable transparent cover.
- G** QR code to access product information.
- H** ULP status LED.
- I** Test button (accessible with cover closed).
- J** Locking pad.
- L** Device name label.
- M** ULP ports.

DB418230.eps

DB425732-2.eps



DB425733.eps

Components

IFE switchboard server



IFE switchboard server, ref.: LV434002

D

IFE switchboard server description

Introduction

The IFE switchboard server enable LV circuit breakers to be connected to an Ethernet network. The IFE switchboard server incorporates a Modbus gateway. The IFE switchboard server are both equipped with two ULP ports and two Ethernet ports. The IFE switchboard server is equipped with a Modbus RS 485 serial connection. The following circuit breakers can be connected to IFE interface and to IFE switchboard server: Fixed type MasterPacT MTZ, ComPacT NSX or PowerPacT.

IFE switchboard server: ref. LV434002

Provides an Ethernet access to one or several LV circuit breakers. It acts as an Ethernet interface for:

- One single circuit breaker connected to the IFE interface via its ULP port and a prefabricated ULP cord,
- Up to 12 ComPacT NSX connected through the Modbus serial line interface. Each ComPacT NSX is connected to Modbus by means of a dedicated IFM interface module performing the ULP/Modbus conversion. The connection between each ComPacT NSX and its associated IFM interface is realized by a prefabricated ULP cord connected to ULP ports.

IFE switchboard server

- Dual 10/100 Mbps Ethernet port for simple daisy chain connection.
- Device profile web service for discovery of the IFE interface and IFE switchboard server on the LAN.
- ULP compliant for localization of the IFE interface in the switchboard.
- Ethernet interface for MasterPacT, ComPacT and PowerPacT circuit breakers.
- Support of Modbus TCP/IP communication protocol
- Gateway for Modbus-SL connected devices
- Embedded set-up web pages.
- Embedded monitoring web pages.
- Embedded control web pages.
- Built-in e-mail alarm notification.
- Internal real-time clock with battery back-up.
- RSTP (Rapid Spanning Tree Protocol) for implementing redundant Ethernet networks.
- NTP (network time protocol) for precise time synchronization

Mounting

The IFE switchboard server is mounted on a DIN rail.

A stacking accessory enables the user to connect several IFMs (ULP to Modbus serial line interfaces) to an IFE switchboard server without additional wiring.

24 V DC power supply

The IFE switchboard server must have either a 24 V DC AD or a 24 V DC ABL8 RPS power supply.

The IFMs stacked to an IFE switchboard server are supplied with power by the IFE, thus it is not necessary to supply them separately.

Note: The connection of the +/- of the power supply to the +/- terminals of the IFE device must be strictly respected. Inverting the polarities may damage the device.

IFE switchboard server firmware update

The firmware can be updated using the EcoStruxure Power Commission software.

Required circuit breaker communication modules

The connection to the IFE interface or IFE switchboard server requires ULP communication ports. Every fixed-type MasterPacT MTZ circuit breaker is equipped with a ULP port connected to its associated IFE Ethernet interface module by a prefabricated ULP cord. The IFE Ethernet interface modules are equipped with two ULP RJ45 connectors. When one is not used, it must be closed off with a ULP terminator.

Components

IFE switchboard server

DB418230.eps

DB425732.eps

DB425733.eps



General characteristics		
Environmental characteristics		
Conforming to standards	IEC 60950, IEC 60947-6-2, UL 508, UL 60950, IACS E10	
Certification	c UL us, CE, EAC, FCC marking	
Ambient temperature	storage	-40 to +85 °C
	operation	-25 to +70 °C
Relative humidity	5 - 85 %	
Level of pollution	Level 3	
Protective treatment	ULV0 conforming to IEC/EN 60068-2-30	
Mechanical characteristics		
Shock resistance	Conforming to IEC/EN 60068-2-27 15 g / 11 ms, 1/2 sinusoidal	
Resistance to sinusoidal vibrations	Conforming to IEC/EN 60068-2-6 5 Hz < f < 8.4 Hz	
Electrical characteristics		
Consumption	150 mA at 24 V DC	
Resistance to electrostatic discharge	IEC/EN 61000-4-2: ■ 8 kV air discharge ■ 6 kV contact discharge	
Immunity to radiated fields	IEC/EN 61000-4-3: 10 V/m	
Immunity to fast transient disturbances	IEC/EN 61000-4-4: 2 kV	
Immunity to surges	IEC/EN 61000-4-5: 2 kV common mode	
Immunity to conducted radio frequency field	IEC/EN 61000-4-6: 10 V	
Physical characteristics		
Dimensions	72 x 105 x 71 mm	
Mounting	DIN rail	
Weight	182.5 g (0.41 lb)	
Degree of protection of the installed I/O	■ On the front panel (wall mounted enclosure): IP4x ■ Connectors: IP2x ■ Other parts: IP3x	
Connections	Screw-type terminal blocks	

IFE web page description

Monitoring web page:

- Real-time data
- Device logging

Control web page:

- Single-device control

Diagnostics web page:

- Statistics
- Device information
- IMU information
- Device register reading
- Communication check

Maintenance web page:

- Circuit breaker health status
- Maintenance log
- Maintenance counters

Setup web page:

- Device localization/name
- Ethernet configuration (dual port)
- IP configuration
- Modbus TCP/IP filtering
- Date and time
- E-mail server configuration
- Alarms to be e-mailed
- Device logging
- Device log export
- SNMP parameters
- Preferences
- Advanced service control
- User accounts
- Web page access

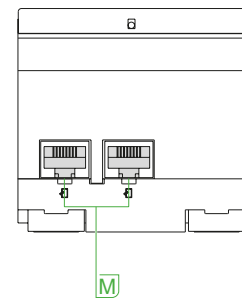
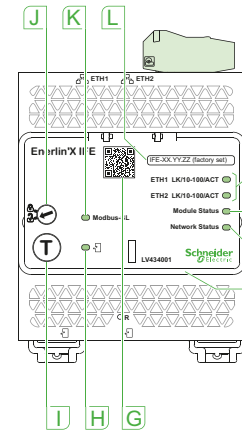
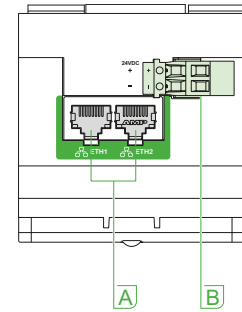

- A** Ethernet 1 and Ethernet 2 communication port.
- B** 24 V DC power supply terminal block.
- C** Ethernet communication LEDs:
yellow: 10 Mb
green: 100 Mb.
- D** Module status LED:
steady off: no power
steady green: device operational
steady red: major fault
flashing green: standby
flashing red: minor fault
flashing green/red: self-test.
- E** Network status LED:
steady off: no power/no valid IP address
steady green: connected, valid IP address
steady orange: default IP address
steady red: duplicated IP address
flashing green/red: self-test.
- F** Sealable transparent cover.
- G** QR code to access product information.
- H** ULP status LED.
- I** Test button (accessible with cover closed).
- J** Locking pad.
- K** Modbus traffic status LED.
- L** Device name label.
- M** ULP ports.

Components

IFM Modbus interface



PB119111.eps

IFM Modbus communication interface.
Ref.: LV434000.

Function

Modbus communication interface (IFM) is required for connecting a MasterPacT MTZ/NT/NW or ComPacT NS/NSX circuit breaker to Modbus network whenever the circuit breaker has an ULP port (Universal Logic Plug). The port is available on BCIM ULP for MasterPacT range and BSCM module for ComPacT range.

Note: IFM is defined as an IMU (Intelligent Modular Unit) within the ULP connection System documentation.

Once connected to IFM, the circuit breaker is considered as a server by the Modbus client. Its electrical values, alarm status, open/close signals can be monitored or controlled by a Programmable Logic Controller or any other system.

Characteristics

ULP port

2 RJ45 sockets, internal parallel wiring.

- Connection of a single circuit breaker.
 - An ULP line terminator must be connected to the second RJ45 ULP socket. The RJ45 sockets deliver a 24 V DC supply fed from the Modbus socket.
- Built-in test function, for checking the correct connection to the circuit breaker.

Modbus server port

- Modbus Serial RJ45 port – RJ45 connector provides fast and reliable wiring.
- Lateral socket, for DIN rail stackable connector.
- Both top and lateral sockets are internally parallel wired.
- Multiple IFM can be stacked, thus sharing a common power supply and Modbus line without individual wiring.
- On the front face:
 - Modbus address setting (1 to 99): 2 coded rotary switches
 - Modbus locking pad: enables or disable the circuit breaker remote control and modification of IFM parameters.
- Self adjusting communication format (Baud rate, parity).

24 V DC power supply

- Screw clamp terminal block
- High electrical insulation between Modbus and 24 V DC connectors
- Separated lines provides improved communication robustness.

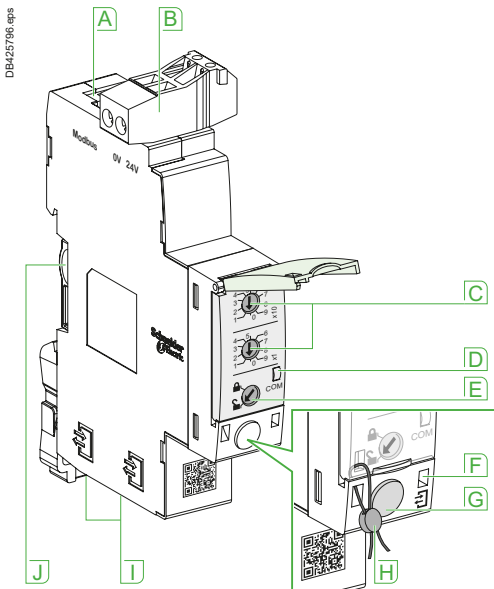

DB425796.eps

- A** Modbus Serial RJ45 port.
- B** 0-24 V DC power supply.
- C** Modbus address switches.
- D** Modbus traffic LED
- E** Modbus locking pad.
- F** ULP activity LED.
- G** Test button.
- H** Mechanical lock and locking seal.
- I** ULP RJ45 connectors.
- J** Stacking accessory connection.

General characteristics	
Environmental Characteristics	
Conforming to standards	IEC 61010, IEC 60950, UL 61010, UL 60950, CISPR 22, 24, 11, IACS E10
Certification	c UL us, CE, EAC, FCC marking
Ambient temperature	-20 to +70 °C
Relative humidity	5 - 85 %
Level of pollution	Level 3
Protective treatment	ULV0 conforming to IEC/EN 60068-2-30
Mechanical characteristics	
Shock resistance	Conforming to IEC/EN 60068-2-27 15 g / 11 ms, 1/2 sinusoidal
Resistance to sinusoidal vibrations	Conforming to IEC/EN 60068-2-6 5 Hz < f < 8.4 Hz
Electrical characteristics	
Consumption	30 mA at 24 V DC
Resistance to electrostatic discharge	IEC/EN 61000-4-2: 8 kV AD
Immunity to radiated fields	IEC/EN 61000-4-3: 10 V/m
Immunity to surges	IEC/EN 61000-4-5: class 2
Physical characteristics	
Dimensions	109 x 73 x 18 mm
Mounting	DIN rail
Weight	120 g
Degree of protection of the installed module	<ul style="list-style-type: none"> ■ IP20 for connectors ■ IP30 for other areas
Connections	<ul style="list-style-type: none"> ■ RJ45 for ULP and Modbus SL ■ Screw type terminals for Power

Recommended IFM installation

Stacking IFM

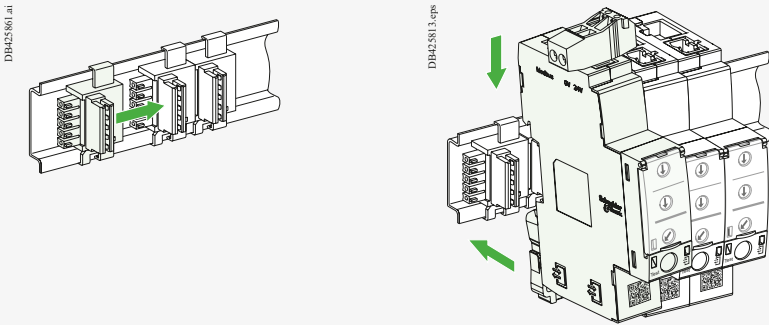

Stacking accessories

Up to 12 stacked IFM

Stacking an IFE switchboard server with IFMs

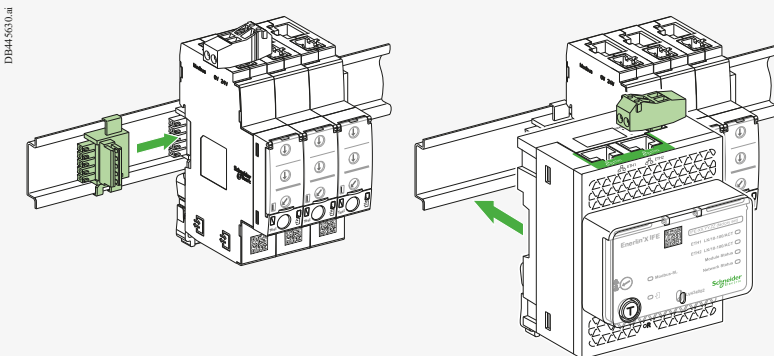

Architecture components

FDM121 Display Unit

MicroLogic Active measurement capabilities come into full play with the FDM121 switchboard display. It provides an Ethernet connection via RJ45 port and displays MicroLogic Active information.

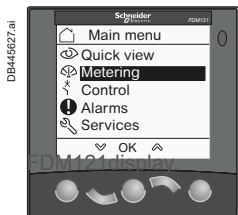

FDM121 display

The FDM121 is a device display. It collects the data from devices via ULP network. It connects to individual breakers:

- MasterPacT MTZ1, MTZ2, MTZ3
- ComPacT NS, NSX

Display of measurements and trips

The FDM121 is intended to display measurements, trips and operating information. It cannot be used to modify the protection settings.

Measurements are easily accessed via a menu.

Trips are automatically displayed.

A pop-up window displays the time-stamped description of the trip.

Status indications

When the circuit breaker is equipped with the Command Module, the FDM121 display can also be used to view circuit breaker status conditions:

- OF: ON/OFF
- CH: spring charged
- SDE: Fault-trip indication (overload, short-circuit, ground fault)
- CE, CD, CT chassis management with EIFE.

Remote control

When the circuit breaker is equipped with communicating voltage releases, the FDM121 display can also be used to control the circuit breaker (issuing of open/close commands).

Key characteristics

- 96x96 mm display 128 x 128 pixels.
- Monochrome, LED backlight.
- Wide viewing angle: 60 x 30°
- Operating temperature range -10 °C to +55 °C.
- CE/UL/CSA marking
- 24 V DC power supply.
- Consumption 21 mA
- Two RJ45 Jack for ULP

Mounting and Protection

- The FDM121 is easily installed in a switchboard.
- The FDM121 degree of protection is IP54

Architecture components

FDM121 Display Unit

Main menu

**General view**

The Quick view menu provides quick access to the information essential for operation.

**Metering**

The Metering menu displays the data made available by the MicroLogic trip unit:

**Control**

The Control menu is used to control a circuit breaker equipped with a communicating motor mechanism from the FDM121 display.

**Alarms**

The Alarms menu.

**Services**

The Services menu contains all the FDM121 display setup functions and the operating assistance information.

Sub menus

Quick view

The Quick view menu provides quick access to the information essential for operation.

Metering

The Metering menu displays the data made available by the MicroLogic trip unit:

- Current, voltage, power, energy, power factor, frequency, and harmonic distortion measurements
- Minimum and maximum metering values

Control

The Control menu is used to control a circuit breaker equipped with a communicating motor mechanism from the FDM121 display.

The proposed commands are:

- Circuit breaker opening
- Circuit breaker closing with or without self-timer
- Circuit breaker reset after trip
- IO module lighting control
- IO module load control

Alarms

The Alarms menu is used to display:

- The event log file for the last 40 events and alarms detected by the devices connected to the FDM121 display since the last power-up of the FDM121 display.
- The alarm history (for example, alarms, trips, maintenance, and control status) for the device connected to the FDM121 display

Services

The Services menu contains all the FDM121 display setup functions and the operating assistance information:

- Reset (peak demand values, energy meters, minimum and maximum values)
- Setup (display module date and time, parameters, display settings, date and time, units)
- Maintenance (operation counters, load profile)
- Product version (identification of the intelligent modular units)
- Language (choice of language display)
- Monitoring and controlling the IO modules (IO status, forcing command, pulse counters, and temperature)
- Setup of the IP address of the IFE Ethernet interface for one circuit breaker

Architecture components

FDM128 Display Unit ^[1]

MicroLogic Active measurement capabilities come into full play with the FDM128 switchboard display. It connects to Ethernet communication via RJ45 port and displays MicroLogic Active information.



FDM128 display.

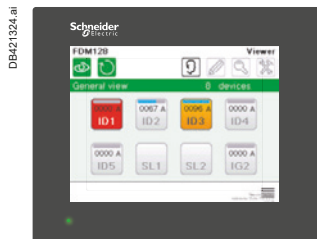

General view

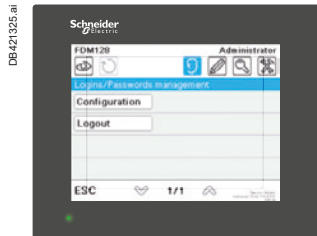

Role base access control



Editing devices

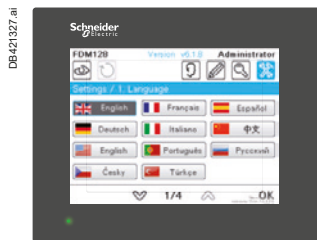

General setting

FDM128 switchboard display

The FDM128 is an intelligent Ethernet touch screen. It collects the data from devices via Ethernet network. It is designed to manage up to 8 devices such as:

- MasterPacT MTZ1, MTZ2, MTZ3
- ComPacT NS
- ComPacT NSX

The FDM128 switchboard display unit can be connected to a MicroLogic Active via an IFE or an EIFE interface module. It is easy to use and requires no special software or programming.

The FDM128 has a large screen. It requires very little depth. The anti-glare graphic screen has a backlight for very easy reading even under poor ambient lighting and at sharp angles.

Display of MicroLogic Active measurements and trips

The FDM128 is intended to display MicroLogic Active measurements, trips and operating information. It cannot be used to modify the protection settings. Measurements are easily accessed via a menu.

Trips are automatically displayed.

A pop-up window displays the time-stamped description of the trip.

Status indications

When the circuit breaker is equipped with the Command Module, the FDM128 display can also be used to view circuit breaker status conditions:

- OF: ON/OFF
- CH: spring charged
- SDE: Fault-trip indication (overload, short-circuit, ground fault)
- CE, CD, CT chassis management with EIFE.

Remote control

When the circuit breaker is equipped with Communicating voltage releases, the FDM128 display can also be used to control the circuit breaker (issuing of open/close commands).

Key characteristics

- 115.2 x 86.4 mm with 5.7" QVGA display 320 x 240 pixels.
- Color TFT LCD, LED backlight.
- Wide viewing angle: vertical $\pm 80^\circ$, horizontal $\pm 70^\circ$.
- High resolution: excellent reading of graphic symbols.
- Operating temperature range -10°C to $+55^\circ\text{C}$.
- CE/UL/CSA marking.
- 24 V DC power supply.
- Consumption $\leq 6.8\text{ W}$.
- One RJ45 Ethernet jack.

Mounting and Protection

- The FDM128 is easily installed in a switchboard.
- Standard door hole $\text{Ø}22\text{ mm}$.
- The FDM128 degree of protection is IP65.

[1] Available soon.



Architecture components

FDM128 Display Unit

Main menu

- General view**
 The Quick view menu provides quick access to the information essential for operation.
- Role base access control**
 Manage logins and passwords.
- Editing devices**
 Specify the devices monitored by the FDM128.
- Communication setting**
 Set the communication parameters.
- General setting**
 Select the language and to set the other parameters of FDM128.

Sub menus

- Quick view**
 Provides access to five screens that display a summary of essential operating information (I, U, f, P, E, THD, circuit breaker On/off), protection settings.
- Measures**
 Display all the measurements (I, U, V, f, P, Q, S, E, THD, PF) with the corresponding min/max values.
- Alarms history**
 Display tripping and alarms histories.
- Control**
 Display the status of the devices (Open/Closed) and to initiate control commands (Open/Close/Reset)
- Maintenance**
 Display all circuit breaker health status indications and all the information generated by the diagnostic functions (number of operations, contact wear etc.)

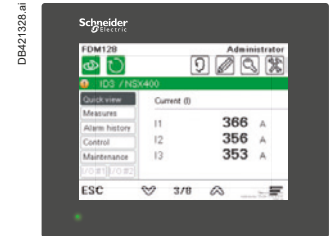

Quick view

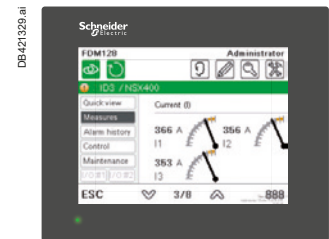

Measures

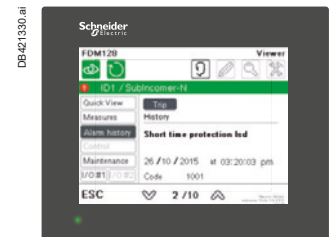

Alarm history

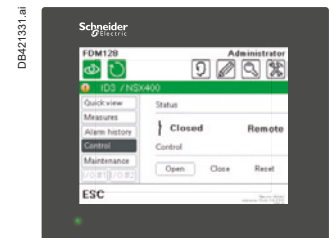

Control



Maintenance



Customer engineering tool: EcoStruxure Power Commission software

EcoStruxure PowerCommission Experience Project Lifecycle

PB124058.eps



Maintain

Facility managers
Software to track installation changes & diagnostic features for preventive maintenance

EcoStruxure Power Design

EcoStruxure Power Build

EcoStruxure Power Commission

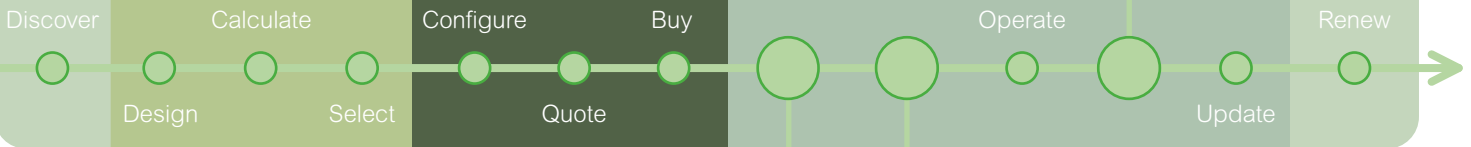

Build

Panel builders
Simple & easy software to set up and test a panelboard



Commission

Electrical contractors & system integrator
Shorten commissioning time and speed up SAT delivery with easy-to-use software

Key Features

Build

I want to test & deliver a “ready to commission” panel

- Device Discovery
- Switchboard setting & testing
- Communication Test & Reports
- Save my project & reports
- Circuit Breaker Functional Tests

Commission

I want to “shorten” my commissioning time

- Device Discovery
- Multi Device Configuration
- Communication Test & Reports
- Save my project & reports

Maintain

I want to ensure “continuity” of services in “safe conditions”

- Settings consistency check
- Device checkup
- Firmware upgrade
- Standard Diagnostic data
- Save my project & reports
- Circuit Breaker Functional Tests

Integrate in Smart Panels - Architecture and Systems

Customer engineering tool: EcoStruxure Power Commission software

EcoStruxure Power Commission Software

Definition

EcoStruxure Power Commission software helps the user to manage a project as part of the testing, site commissioning, and maintenance phases of the project life cycle. With EcoStruxure Power Commission, you will get your electrical devices configured, tested and commissioned in the simplest way. EcoStruxure Power Commission drastically reduces the commissioning time of Smart Panels and supports the system during maintenance.

It allows the user to set up, test and generate comprehensive reports for connected panels and circuit breakers, track and digitize assets for paperless sharing of project documents and perform firmware upgrade of communicating devices.

EcoStruxure Power Commission offers value added features like automatic discovery of connected devices. It performs communication tests, generates reports as part of FAT reports. It generates comprehensive reports as part of SAT reports, upgrade firmware etc.

Key Features

Device Discovery

EcoStruxure Power Commission helps the user to discover the communicating devices in a switchboard either through Ethernet (using automatic or manual discovery) or a serial network. Once the devices in the switchboard are discovered, the user can add those devices to the project.

Device settings

- EcoStruxure Power Commission helps the user to set the protection settings and the alarms of the devices, MasterPacT MTZ (including dual settings only for MasterPacT MTZ) and BCIM I/O configuration. It allows configuration or settings to be downloaded and uploaded for multiple devices. The user can also compare settings between the project (original settings) and device (current settings).
- EcoStruxure Power Commission also reads information (alarms, measurements, parameters) and displays diagnostic information.

Communication Test

When a user has installed communicating devices in a switchboard, EcoStruxure Power Commission offers the capability to test the communication network. Once a communication test is done, the user can generate a time stamped communication test report.

Circuit Breaker Tests & Maintenance

Users can test the protection trip curve and other functions for low voltage circuit breakers using EcoStruxure Power Commission. The following tests can be performed:

- Automatic trip curve test
- Zone-selective interlocking test
- Prepare for primary injection tests
- Breaker status and cradle position test

Customer engineering tool: EcoStruxure Power Commission software

Reports

EcoStruxure Power Commission offers the following reports to the users:

- Communication test report
- Comprehensive project report
- Automatic trip test report
- Breaker status and cradle position test report
- Circuit breaker advanced maintenance report
- Modbus registers extract report

Firmware Upgrade

EcoStruxure Power Commission offers the compatibility check and firmware upgrade for the following devices:

- MicroLogic Active control units
- EIFE/IFE
- I/O modules
- EcoStruxure Panel Server
- Power meters

USB and Ethernet interfaces

EcoStruxure Power Commission provides access to MasterPacT MTZ through USB and Ethernet interfaces.

The following table indicates the features that are accessible through each interface:

Features	USB	Ethernet
Protection/Alarm settings	Yes	Yes
Firmware upgrade	Yes	Yes
Device Checkup	Yes	Yes
Prepare for primary injection tests	Yes	No
Automatic trip curve test	Yes	No
Zone-selective interlocking test	Yes	No

D

Integrate in Smart Panels - Architecture and Systems

Customer engineering tool: EcoStruxure Power Commission software

Screen: Device homepage

The user can connect to the device from the device home page and do the settings configuration, do a device check up, view maintenance information, upgrade the device with the latest firmware.

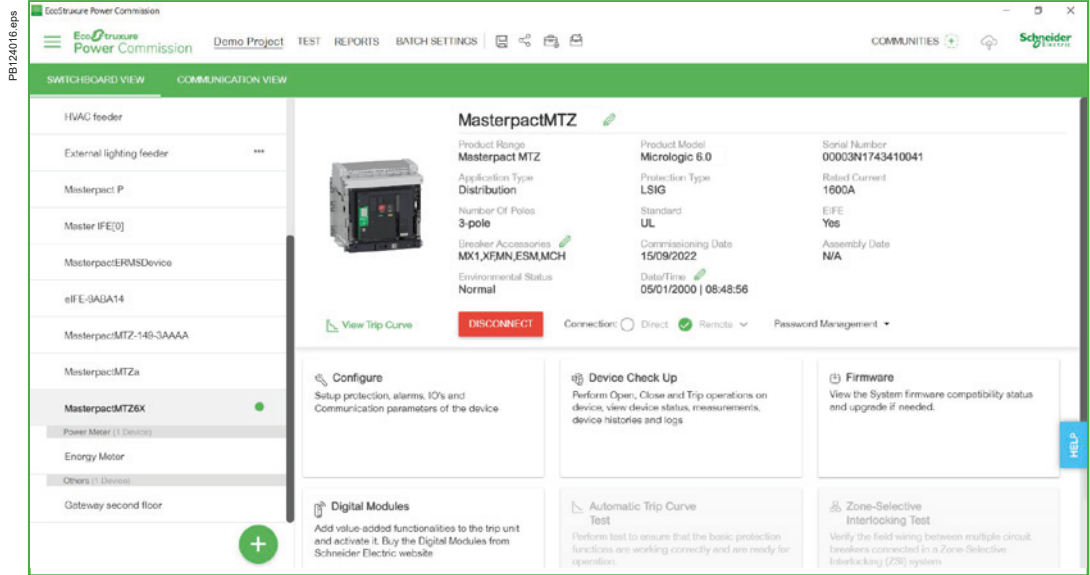

Screen: Device Configure

Once the user clicks on **Configure**, the below screens appear, through which the user can set up protection, alarms, IO's and Communication parameters of the device.

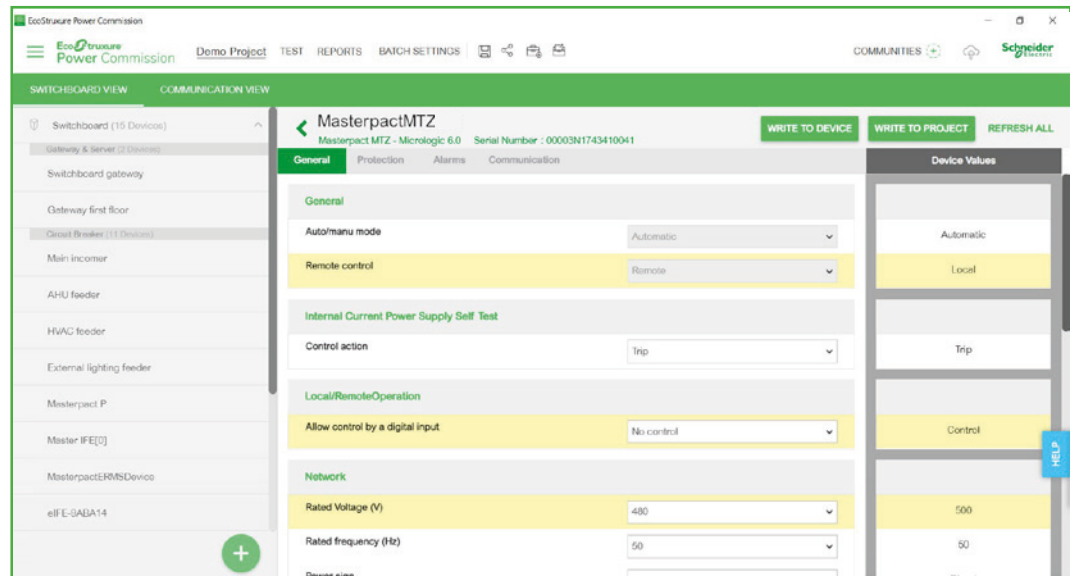

Customer engineering tool: EcoStruxure Power Commission software

Screen: Device Check up

On clicking **Device Check Up**, the below screens appear, through which the user can perform Open, Close and Trip Operations on device, view device status, measurements, device histories and logs.

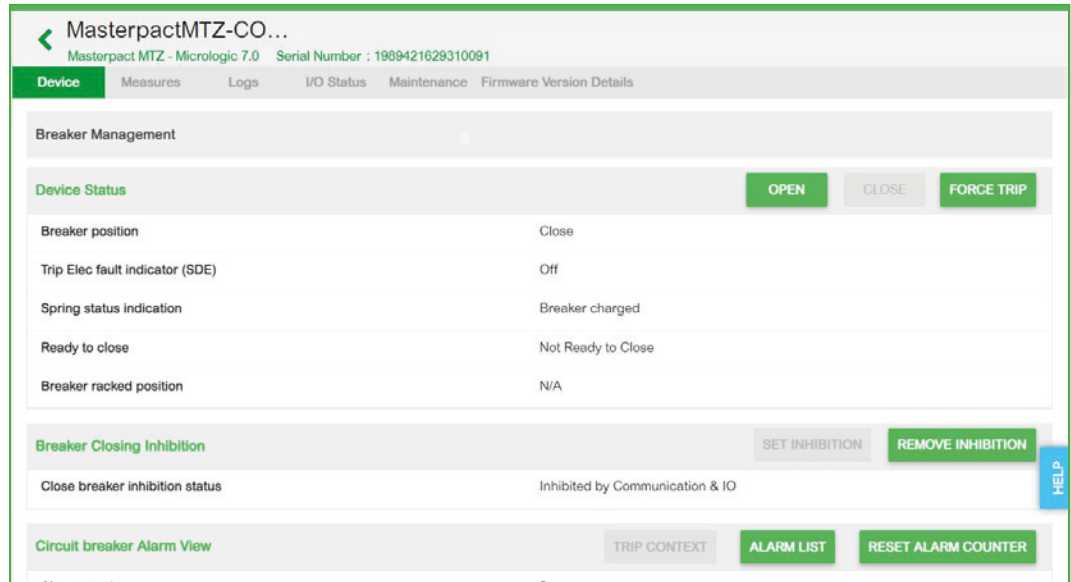

Screen: Firmware upgrade

Through the **Firmware Upgrade** screen, a user can check the compatibility of the firmware versions of the devices and modules connected and upgrade them when needed with the device firmware baseline file.

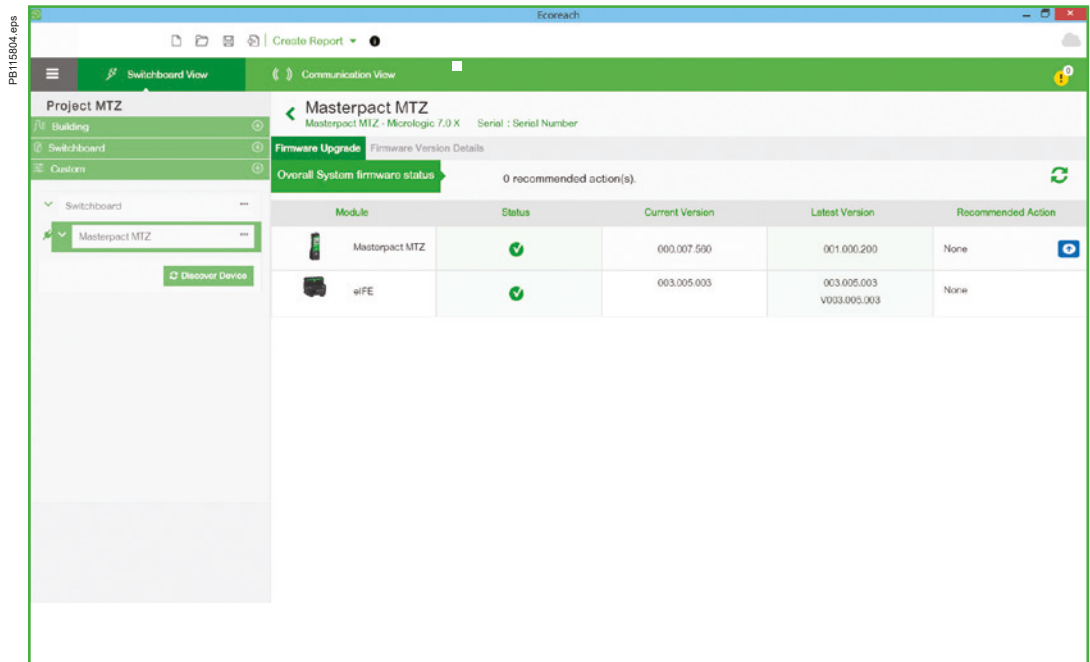

D

Integrate in a Switchboard

Operating conditions E-2

Installation rules

Installation in switchboard E-6

Door interlock catch E-8

Power connection E-10

Recommended busbar drilling for MasterPacT MTZ1 E-12

Recommended busbar drilling for MasterPacT MTZ2 - MTZ3 E-13

Temperature derating E-14

Busbar sizing, front or rear horizontal connection E-16

Busbar sizing rear vertical connection E-17

Circuit breaker derating E-18

Dimensions

MasterPacT MTZ1 fixed 3/4-pole devices E-25

MasterPacT MTZ1 drawout 3/4-pole devices E-30

MasterPacT MTZ2 08 to MTZ2 32 fixed 3/4-pole devices E-34

MasterPacT MTZ2 08 to MTZ2 32 drawout 3/4-pole devices E-36

MasterPacT MTZ2 40 fixed 3/4-pole devices E-38

MasterPacT MTZ2 40 drawout 3/4-pole devices E-40

MasterPacT MTZ3 fixed 3/4-pole devices E-42

MasterPacT MTZ3 drawout 3/4-pole devices E-44

Accessories E-46

External modules E-48

Installation

Clusters E-53

Electrical diagrams

MasterPacT MTZ1 fixed and drawout devices E-54

MasterPacT MTZ2/MTZ3 fixed and drawout devices E-56

24 V DC external power supply AD module E-59



Other chapters

- "Select a Circuit Breaker", page A-1
- "Select a MicroLogic Active Control Unit", page B-1
- "Customize your Circuit Breaker with Accessories", page C-1
- "Integrate in Smart Panels - Architecture and Systems", page D-1
- "Integrate in Special Applications Source-Changeover Systems", page F-1
- "Services", page G-1
- "Order your Circuit Breaker", page H-1

MasterPacT MTZ test conditions reproduce different customer environments, in accordance with product and installation standards and relevant maintenance operations ^[1] to **maximize the product lifespan**.

[1] For full details, please read the MasterPacT maintenance guide.

Introduction

MasterPacT MTZ is designed for specified operating conditions in terms of temperature, humidity, vibration, altitude, corrosion, and electromagnetic disturbances.

Beyond the limits defined here, the circuit breakers suffer accelerated aging that may rapidly result in malfunctions.

Please refer to the MasterPacT Maintenance Guide for additional information and consult us to confirm mechanical and electrical performances in extreme conditions.

Example of application with extreme operating conditions:

- Power frequency converters installed in the same switchboard or close to the MasterPacT circuit breaker
- Emergency generators.

Safety of operation

MasterPacT MTZ front face provides reinforced insulation (Class 2) according to IEC 60664-1. It allows Class 2 installation with breaker control from outside.

Ambient temperature

MasterPacT MTZ is designed to operate in ambient temperature between -25 °C and +70 °C, providing that the temperature around the breaker inside the switchboard does not exceed +70 °C. If this condition cannot be fulfilled, dedicated measures such as HVAC must be taken.

MasterPacT devices have successfully passed the tests defined by the following standards for extreme atmospheric conditions:

- IEC 60068-2-1: dry cold at -40 °C
- IEC 60068-2-2: dry heat at +85 °C
- IEC 60068-2-30: damp heat (temperature +55 °C, relative humidity 95 %).

Nota: The indication of +55 °C with relative humidity of 95 % applies to test conditions. This does not apply to normal, long term operational conditions for MasterPacT MTZ.

Shipping & Storage		Installation & Commissioning		Operation inside the switchboard surrounding the circuit breaker [2]	
MasterPacT MTZ					
Temperature (°C)	Relative Humidity (%)	Temperature (°C)	Relative Humidity (%)	Temperature (°C)	Relative Humidity (%)
-40 °C/+85 °C	0...95 %	-25 °C/+70 °C	0...95 %	-25 °C/+70 °C	0...95 %

[2] Manual closing of circuit breaker (using pushbutton) is possible down to -35 °C.

Not all the combinations between temperature and humidity ranges are consistent with the correct shipping, storage, commissioning and operation of MasterPacT MTZ. Please contact Schneider Electric if more information is needed.

Vibrations

MasterPacT devices have successfully passed testing in compliance with IEC 60068-2-6 for the following vibration levels:

- 2 to 13.2 Hz: amplitude ±1 mm
- 13.2 to 100 Hz: constant acceleration 0.7 g.

MTZ2 and MTZ3 withdrawable circuit breakers shall be equipped with the vibration kit for marine applications.

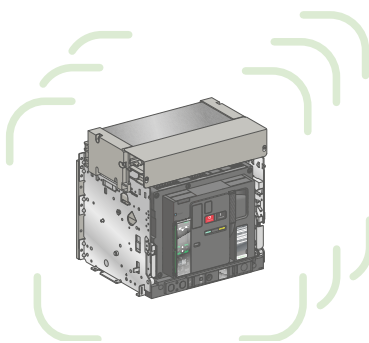
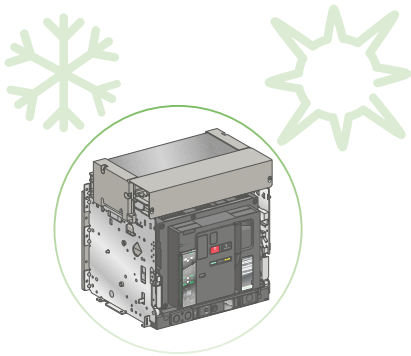

DB439972.ai

DB439973.ai

Industrial environmental atmospheric conditions

MasterPacT devices can operate in the industrial environments defined by standard IEC/EN 60947-1 (pollution degree up to 3).

It is nevertheless advised to check that the devices are installed in suitably cooled switchboards without excessive dust.

Profile	Relevant standard
Corrosive industrial atmospheres	Category 3C2 as per IEC 60721-3-3
Salt mist	Level 2 as per IEC 60068-2-52
Mechanically active substances	Category 3S3 as per IEC 60721-3-3

Beyond these conditions, MasterPacT MTZ must be installed inside switchboards with an IP rating equal to or greater than IP54.

Altitude

At altitudes above 2000 meters, the characteristics of the ambient air (electrical resistance, cooling capacity) lower the product characteristics as follows:

Altitude (m)		2000	3000	4000	5000
Impulse withstand voltage U_{imp} (kV)		12	11	10	8
Rated insulation voltage (U_i)	MTZ1	1000	900	780	700
	MTZ2				
	MTZ3				
Maximum rated operational voltage 50/60 Hz U_e (V)	MTZ2 H10	1250	1110	993	878
	MTZ1 except H3, MTZ2, MTZ3	690	690	630	560
Rated current 40 °C	MTZ2	1150	1022	914	808
		1 x I_n	0.99 x I_n	0.96 x I_n	0.94 x I_n

Note: Intermediate values can be obtained by interpolation.

Electromagnetic disturbances

MasterPacT devices are protected against:

- Overvoltages caused by devices that generate electromagnetic disturbances
- Overvoltages caused by atmospheric disturbances or by a distribution-system outage (for example, failure of a lighting system)
- Devices emitting radio waves (radios, walkie-talkies, radar, etc.)
- Electrostatic discharges produced by users.

MasterPacT devices have successfully passed the electromagnetic compatibility tests (EMC) defined by IEC/EN 60947-2, Annex F.

The above tests ensure that:

- No nuisance tripping occurs
- Tripping times are respected.

Immunity: ability of a device to operate without damage in the presence of an electromagnetic disturbance.

Susceptibility: inability of a device to operate without damage in the presence of an electromagnetic disturbance.

Conducted interference: disturbances generated by the device and transmitted by the conductors (of power supply, signalling, or control) in the form of electrical voltage.

Radiated interference: disturbances generated by the device and radiated in the environment in the form of electromagnetic waves.

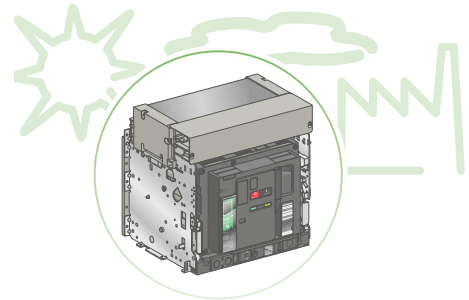

DB439974.ai

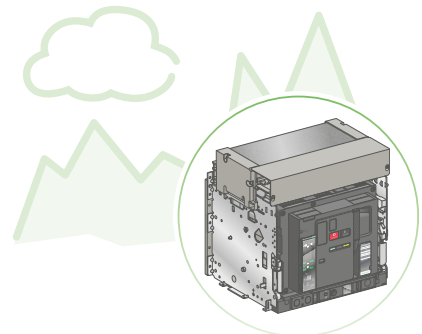

DB439975.ai

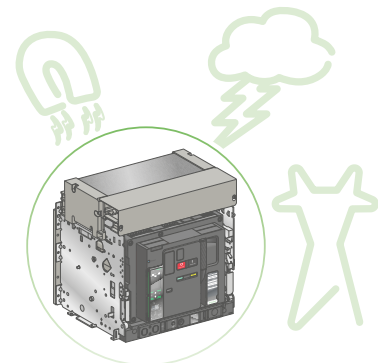

DB439976.ai



DE43977.ai

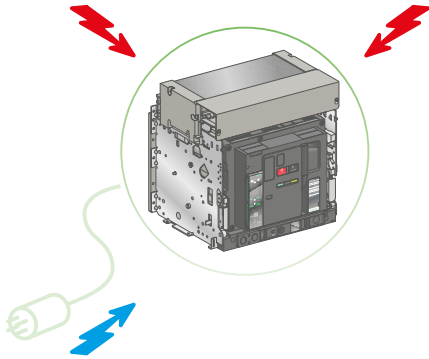

E

DE43978.ai

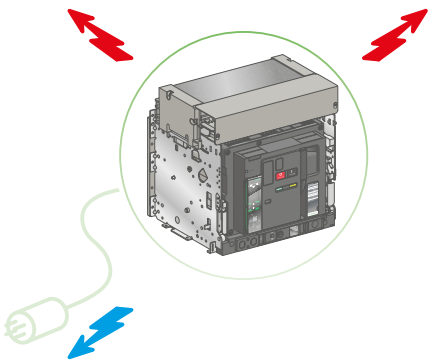

— Radiated
— Conducted

Immunity

Electromagnetic compatibility (EMC)

Standard **Level**

Conducted disturbances

Electrical fast transient/ burst (EFBT/B) IEC 61000-4-4 -

Surges IEC 61000-4-5 4

Conducted disturbances induced by radio-frequency fields IEC 61000-4-6 4

Voltage dips, voltage sags, voltage interruption (only on voltage releases AC supply) IEC 61000-4-11 -

Conducted low frequency IACS - E10 (§15) -

Harmonics and Interharmonics including mains signalling at a.c. power ports IEC 61000-4-13 3

Immunity to conducted, common mode disturbances of main frequencies IEC 61000-4-16 3

Oscillatory wave IEC 61000-4-18 -

Voltage dips, voltage sags, voltage interruption (DC supply) IEC 61000-4-29 -

Radiated disturbances

Electrostatic discharge IEC 61000-4-2 3

Radiated radio-frequency electromagnetic fields IEC 61000-4-3 3

Power frequency magnetic fields IEC 61000-4-8 -

Impulse magnetic field IEC 61000-4-9 5

Oscillatory magnetic field IEC 61000-4-10 -

Radiated fields in close proximity IEC 61000-4-39 -

Emission

Conducted disturbances

Limits for harmonic current emissions IEC 61000-3-2 A

Conducted emission CISPR 11/32/16-2-1 A

Conducted emission CISPR 11/32/16-2-1 B

Radiated disturbances

Radiated emission CISPR 11/32/16-2-3 A

Radiated emission CISPR 11/32/16-2-3 B

EMC and ERM tests compliant with: RED Directive -

■ ETSI EN 300 330 [NFC]

■ ETSI EN 300 328 [IEEE, Bluetooth]

■ ESTI EN 310 489-1 [NFC, IEEE, Bluetooth]

■ ESTI EN 310 489-3 [NFC]

■ ESTI EN 310 489-17 [IEEE, Bluetooth]

Additional EMC Tests not mandatory by IEC 60947-2 and extra EMC performances.

Test values required by IEC/EN 60947-2

MasterPacT MTZ MicroLogic Active tested extra EMC performances

4 kV ; 5 kHz on poles and all AC supplies
2 kV ; 5 kHz on auxiliaries DC supply and signal ports
4 kV CM, 2 kV DM on poles and AC supply > 100 V
2 kV CM, 1 kV DM on AC supply < 100 V

10 V CM; 0.15...80 MHz
40 % (10/12 cycles); 70 % (25/30 cycles)
0 % (1 cycle); 0 % (250/300 cycles)

4 kV ; 5 kHz and 100 kHz on poles and all AC supplies
2 kV ; 5 kHz and 100 kHz on auxiliaries DC supply and signal ports
6 kV CM, 4.4 kV DM on poles.
4 kV CM, 2 kV DM on MX-XF-MN voltage releases for supply > 100 V.
2 kV CM, 1 kV DM on MX-XF-MN voltage releases for supply < 100 V.
2 kV CM, 1 kV DM on 24 V DC supply.
2 kV CM, on all signals ports.
20 V CM; 0.15...80 MHz
40 % (10/12 cycles); 70 % (25/30 cycles); 80 % (250/300 cycles), reinforced coils only.
0 % (0.5 cycle); 0 % (1 cycle); 0 % (250/300 cycles), reinforced coils only.

External power supply failure:
■ 3 interruptions during 5 minutes;
■ switching-off time 30 s each case
Combined voltage and frequency variations
AC: 50 Hz to 10 kHz; 10 % of the rated voltage supply up to harmonic 15. Then reduction at 1% up to harmonic 100, min 3 V RMS.
D: 50 Hz to 10 kHz; Test voltage 10 % of the maximum voltage supply 2 W.
AC supply of devices < 16A, reinforced coils only.

10-1 V; CM; 15-150 Hz; 1 V; CM; 0.15-1.5 kHz
1-10 V; CM; 1.5-15 kHz; 10 V; CM; 15-150 kHz
2.5 kV CM, 2.5 kV DM; 1 MHz
40 % (0.1 s & 0.2 s); 70 % (0.1 s & 0.5 s)
0 % (0.01 s & 0.02 s); 0 % (5 s)
External power supply failure:
■ 3 interruptions during 5 minutes;
■ switching-off time 30 s each case
Voltage continuous ±10 %; Voltage cyclic variation 5 %; Voltage ripple 10 %

6 kV contact ; 8 kV air

10 V/m ; 80 MHz to 1 GHz; 1.4 to 6 GHz

8 kV contact; 8 kV air

20 V/m; 80 MHz to 6 GHz

300 A/m continuous; 1000 A/m 3 s; 50/60 Hz
1000 A/m (8/20 µs wave)
100 A/m (100 kHz and 1 MHz)
100V/m 380 to 390MHz 50% pulse modulation at 18 Hz
100V/m 430 to 470MHz 50% pulse modulation at 18 Hz
30V/m 704 to 787MHz 50% pulse modulation at 217 Hz
100V/m 800 to 960MHz 50% pulse modulation at 18 Hz
100V/m 1447.9 to 1462.9MHz 50% pulse modulation at 18 Hz
100V/m 1700 to 1900MHz 50% pulse modulation at 217 Hz
100V/m 2450 to 2570MHz 50% pulse modulation at 217 Hz
100V/m 5100 to 5800MHz 50% pulse modulation at 217 Hz

- Tested on MX, XF, MN voltage releases for 240 V AC / 380 V AC, reinforced coils only.
A
B- With additional filters on MX, XF, MN voltage releases.

A

The tests are applied to the following functions:
■ Bluetooth (Low Energy and Modulation DSSS)
■ Proprietary connectivity
■ NFC (Near Field Communication)



Integrate in a Switchboard

Installation rules

Installation in switchboard

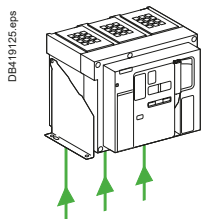

Top and bottom power supply

MasterPacT devices can be supplied either from the top or from the bottom without degrading performance, in order to facilitate connection when installed in a switchboard.

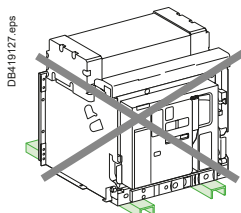
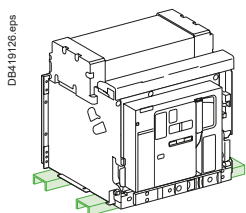

Mounting the circuit breaker

It is important to distribute the weight of the device uniformly over a rigid mounting surface such as rails or a base plate. This mounting plane must be perfectly flat (tolerance on support flatness: 2 mm). This eliminates any risk of deformation which could interfere with correct operation of the circuit breaker. MasterPacT devices can also be mounted on a vertical plane using the special brackets.

Mounting on rails

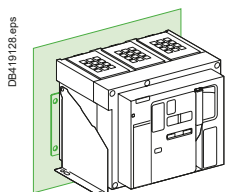

Mounting with vertical brackets

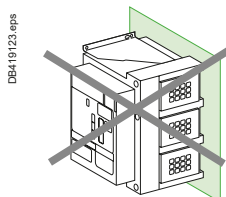
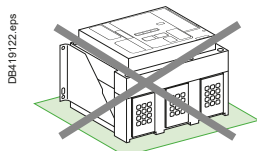

Circuit breaker possible positions

Only one position is authorized.

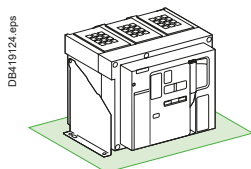

Possible positions

E

Integrate in a Switchboard

Installation rules

Installation in switchboard

Partitions

Sufficient openings must be provided in partitions to ensure good air circulation around the circuit breaker. Any partition between top and bottom connections of the device must be made of non-magnetic material.

For high currents, 2500 A and above, the metal supports or barriers in the immediate vicinity of a conductor must be made of non-magnetic material [1].

Metal barriers [2] through which a conductor passes must not form a magnetic loop.

Busbars (MTZ1, MTZ2/MTZ3)

Creating a magnetic loop around a conductor, (via the busbar support for example), must be strictly avoided.

To avoid this, either the supports [3] and/or the fixing screws [4] must be made of non-magnetic materials.

Interphase barrier

If the insulation distance between phases is not sufficient (≤ 14 mm), it is advised to install interphase barriers (taking into account the clearance distances).

Mandatory for MasterPact MTZ1 for operational voltage $U_e \geq 500$ V, not compatible with spreaders.

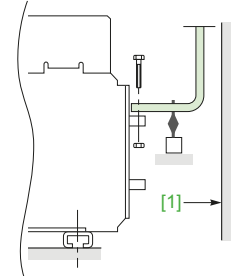

[1] non magnetic material

DB419131.eps

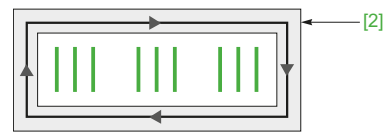

DB419129.eps

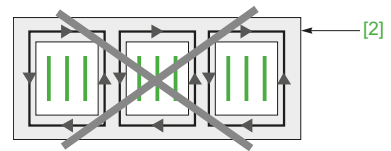

DB419130.eps

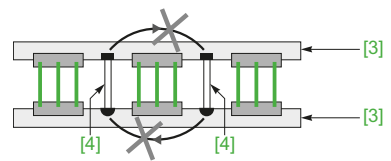

DB419132.eps

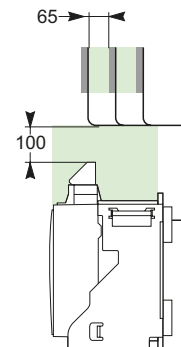

DB419133.eps

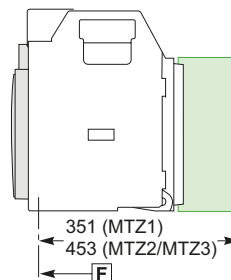

DB419134.eps



Integrate in a Switchboard

Installation rules Door interlock catch

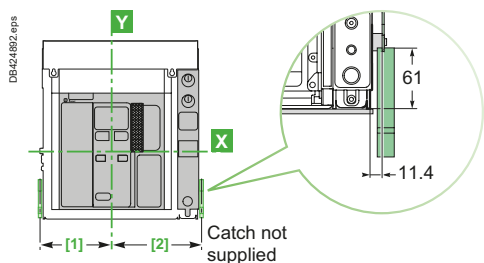

MTZ1

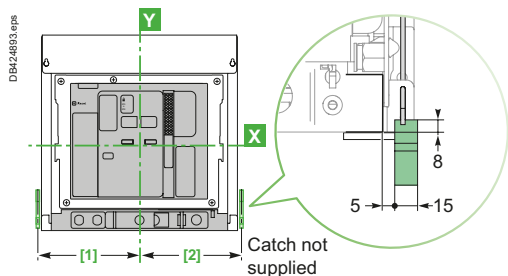

MTZ2 - MTZ3

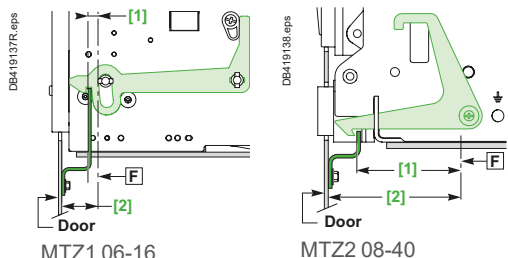

MTZ1 06-16

MTZ2 08-40

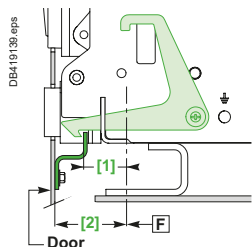

MTZ3 40-63

Door interlock VPEC

Mounted on the right or left-hand side of the chassis, this device inhibits opening of the cubicle door when the circuit breaker is in “connected” or “test” position.

If the breaker is put in the “connected” position with the door open, the door may be closed without having to disconnect the circuit breaker.

Dimensions (mm)

Type	[1]	[2]
MTZ1 08-16 (3P)	135	168
MTZ1 08-16 (4P)	205	168
MTZ2 08-40 (3P)	213	213
MTZ2 08-40 (4P)	328	213
MTZ3 40-63 (3P)	558	213
MTZ3 40-63 (4P)	788	213

Breaker in “connected” or “test” position

Door cannot be opened

Type	[1]	[2]
MTZ1 08-16 (3P)	5	23
MTZ1 08-16 (4P)	5	23
MTZ2 08-40 (3P)	87	103
MTZ2 08-40 (4P)	87	103
MTZ3 40-63 (3P)	37	53
MTZ3 40-63 (4P)	37	53

Integrate in a Switchboard

Installation rules

Door interlock catch

Breaker in “disconnected” position

Door can be opened

Mounted on the right or left-hand side of the chassis, this device inhibits opening of the cubicle door when the circuit breaker is in “connected” or “test” position. If the breaker is put in the “connected” position with the door open, the door may be closed without having to disconnect the circuit breaker.

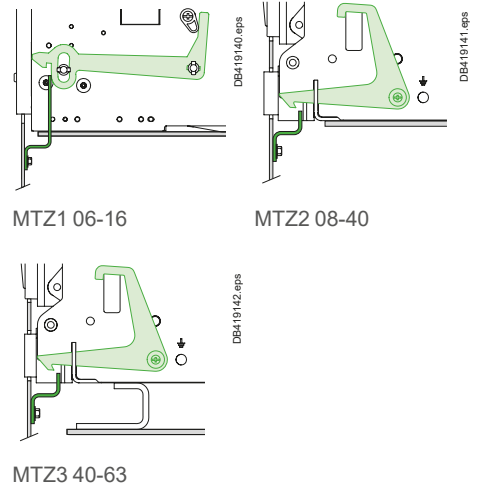

Cable-type door interlock IPA

This option prevents opening the door when the circuit breaker is closed and prevents circuit breaker closing when the door is open. For this, a special plate associated with a lock and a cable is mounted on the right side of the circuit breaker. With this interlock installed, the source changeover function cannot be implemented.

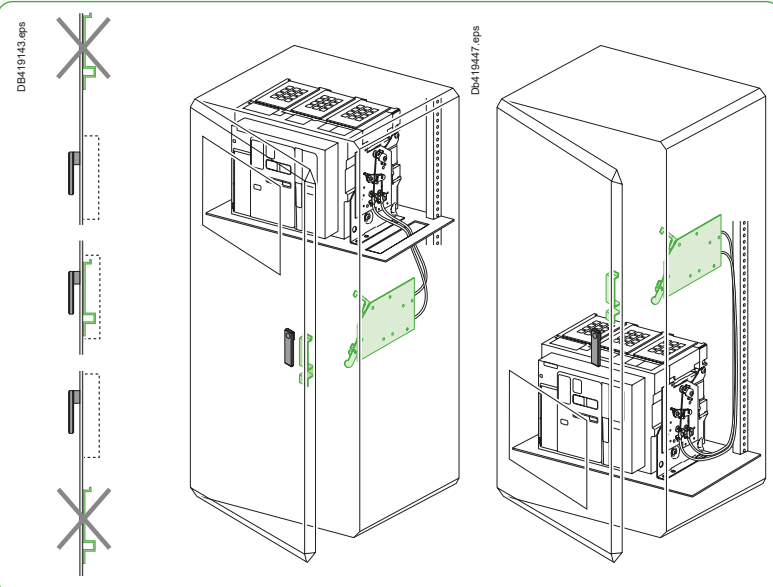
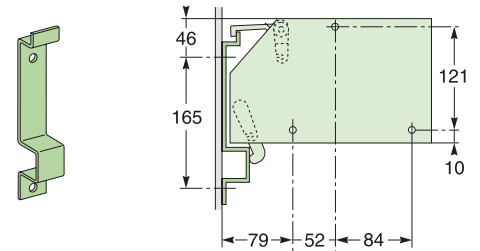

DB419144.eps

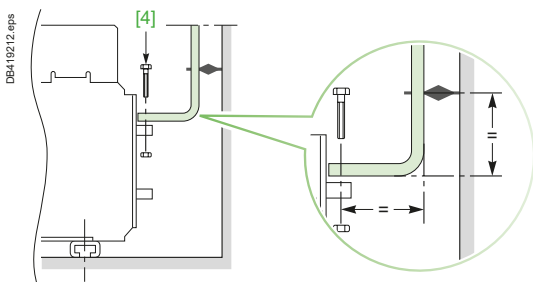
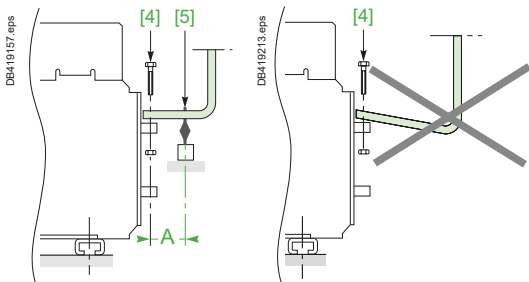
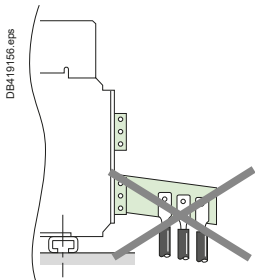
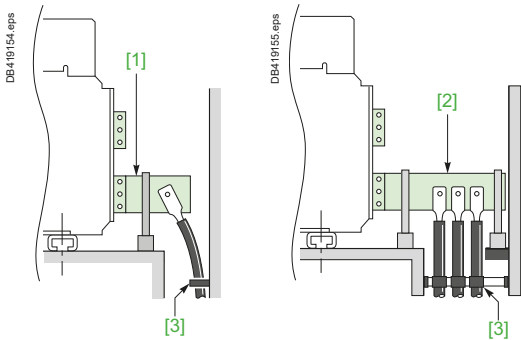

Cable connections

If cables are used for the power connections, make sure that their weight is not applied to the circuit breaker power terminals, but is supported by the panel structure.

For this, proceed as follows for the connections:

- extend the device terminals using short bars designed and installed according to the recommendations for bar-type power connections:
 - for a single cable, use solution [1]
 - for a multiple cables, use solution [2].
- in all cases, follow the general rules for connections to busbars:
 - position the cable lugs before inserting the bolts
 - the cables must be firmly secured to the framework [3].

Busbar connections

Maximum distance A between busbar to circuit breaker connection and the first busbar support or spacer with respect to the value of the prospective short-circuit current.

Isc (kA)	Distance A (mm)
30	350
50	300
65	250
80	150
100	150
150	150

- The busbars must be suitably adjusted to ensure that the connection points are positioned on the power terminals before the bolts [4] are inserted.
- The busbars weight must be supported by the busbar supports [5] that are solidly fixed to the switchboard framework and not by the circuit breaker power terminals.

Electrodynamic stresses

The first busbar support must be situated within a maximum distance (A) from the power terminal of the circuit breaker. This distance must be respected so that the busbar can withstand the electrodynamic stresses between phases in the event of a short circuit. The table above gives the maximum distance (A) according to the prospective short-circuit current I_{sc}.

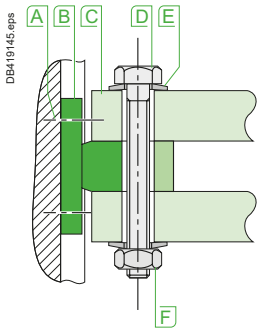

- A** Terminal screw factory-tightened to 13 Nm (MTZ1) and 16 Nm (MTZ2/MTZ3)
- B** Breaker terminal
- C** Busbar
- D** Bolt
- E** Washer
- F** Nut

Clamping

Correct clamping of busbars depends amongst other factors, on the tightening torques used for the nuts and bolts. Over-tightening may have the same consequences as under-tightening. For connecting busbars (Cu ETP-NFA51-100) to the circuit breaker, the tightening torques to be used are shown in the table below. These values are for use with copper busbars and steel nuts and bolts, Class 8.8. The same torques can be used with AGS-T52 quality aluminium bars (French standard NFA 02-104 or American National Standard H-35-1).

Tightening torques			
Ø (mm)	Ø (mm)	Tightening torques (Nm)	Tightening torques (Nm)
Nominal	Drilling	with grower or flat washers	with contact or corrugated washers
10	11	37.5	50

Busbar drilling

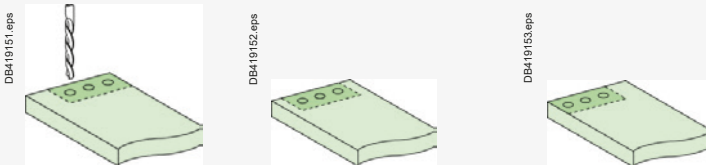

Isolation distance

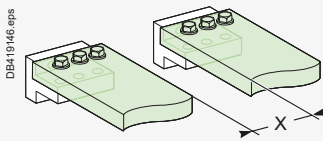

Ui	X min (mm)
600 V	8
1000 V	14

Busbar bending

When bending busbars maintain the radius indicated below (a smaller radius would cause cracks).

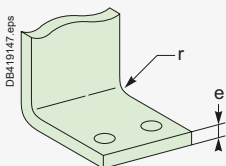

e (mm)	Bending radius r (mm)	
	Min	Recommended
5	5	7.5
10	15	18 to 20

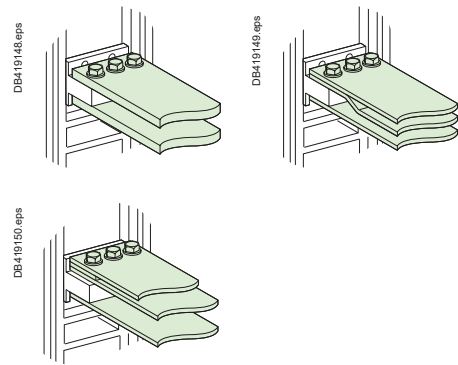

Installation rules

Recommended busbar drilling for MasterPacT MTZ1

Rear connection

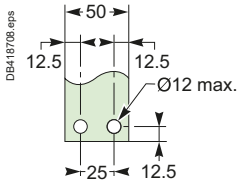

Rear connection with spreaders

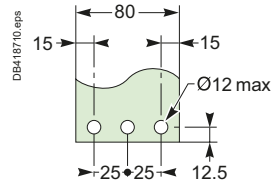
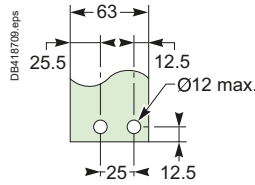
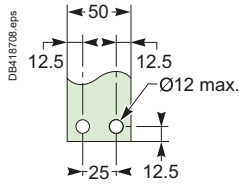

Middle left or middle right spreader for 4P

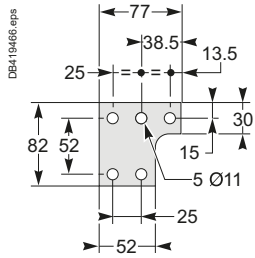
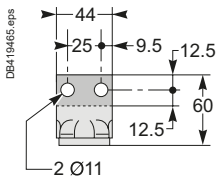

Middle spreader for 3P

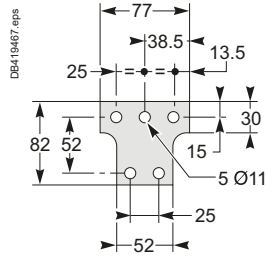

Left or right spreader for 4P

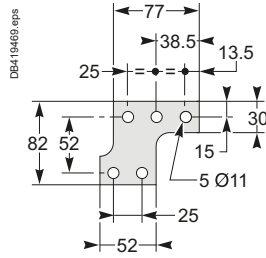

Left or right spreader for 3P

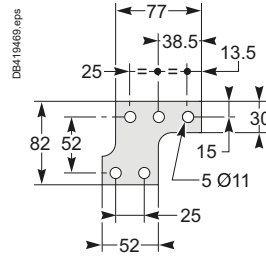

Vertical rear connection

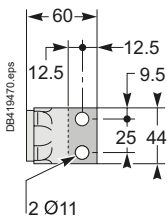
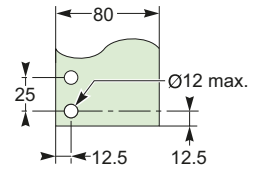
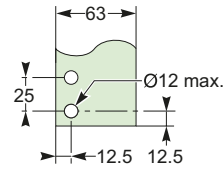
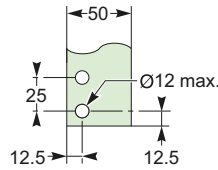
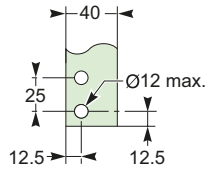
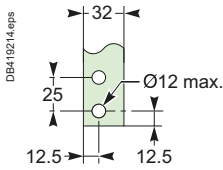

Front connection

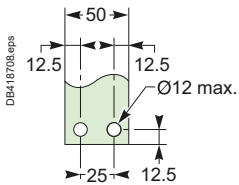

Front connection via vertical connection adapters

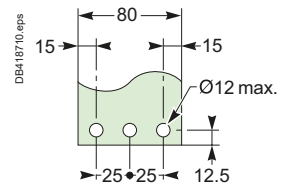
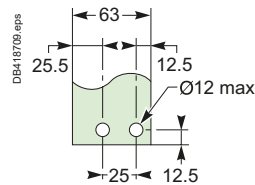
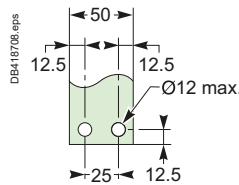

Top connection

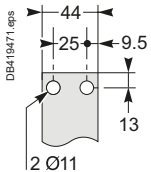

Bottom connection

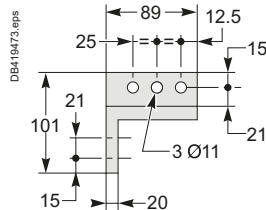
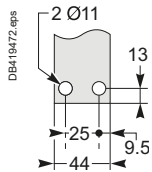

Installation rules

Recommended busbar drilling for MasterPacT MTZ2 - MTZ3

Horizontal rear connection MTZ2 08 to 32

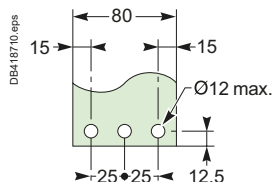
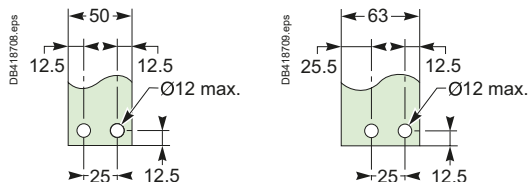

MTZ3 40 to 50

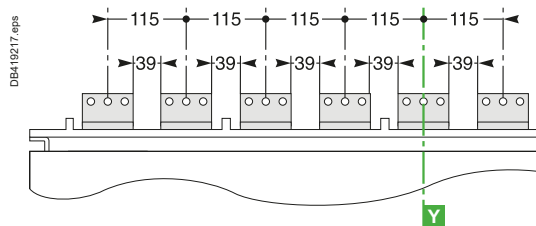
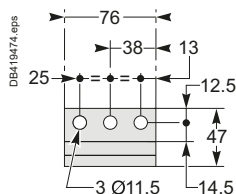
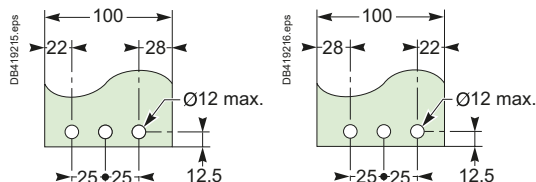

Vertical rear connection MTZ2 08 to 32, MTZ3 40 to 50

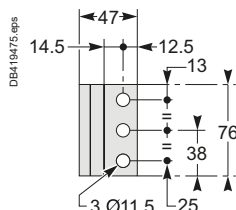
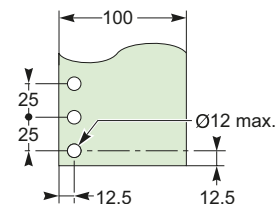
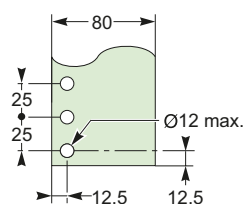
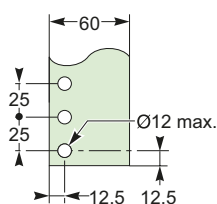
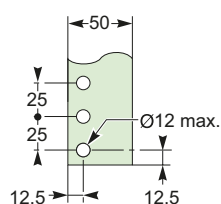
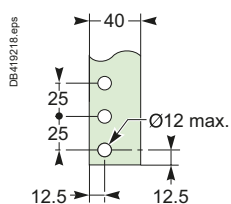

Front connection MTZ2 08 to 32

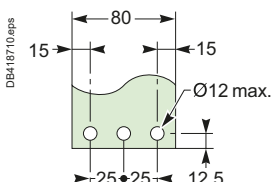
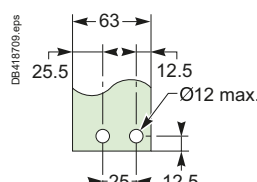
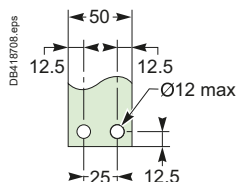

Top connection

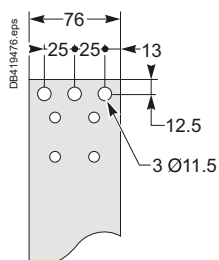

Bottom connection

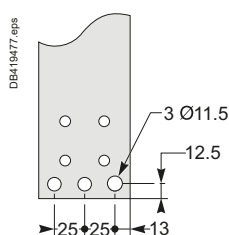

Installation rules

Temperature derating

The current rating of a high-ampere frame circuit breaker is highly dependent on the actual conditions of installation and connection.

In addition to the cross-section of the connecting busbars, there are other strongly influencing factors like their orientation (affecting convection efficiency), their length, their layout (number of bars, shape, spacing, etc. affecting conduction efficiency in a.c.), but also the ventilation and the presence of other devices in the vicinity. Thus it is not possible, for ratings above 1600 A, to give strict values of current rating without performing a temperature rise test in the actual switchboard configuration, as indicated in clause 10.10.4 of IEC 61439-1 (Low Voltage switchgear and controlgear assemblies - Part 1: General rules). Nevertheless, the following pages give guidelines for a first approach of connection sizing, installation conditions, and current rating:

- Pages E-14 and E-15: indicates the maximum current rating depending on the ambient temperature around MasterPacT, with standard busbar sizes as per IEC 60947-2 and IEC 61439-1.

For other busbar sizes, see page E-16 and E-17.

These values are based on tests performed on the circuit breaker alone in free air, as per IEC 60947-2, and give a first approach of the thermal performance of the device in standard conditions. It cannot be fully representative of the actual performance of the device in a switchboard. For derating in switchboards, see Pages E-18 to F-24.

- Page E-16 and E-17: suggests dimension of busbars to reach a given current in a given ambient temperature around the breaker.

- Pages E-18 to F-24: gives the current rating (or derating) of MasterPacT in a switchboard, depending on:

- The ambient temperature around the switchboard
- The ventilation (IP31, IP54)
- The number of breakers in the same column and the position of the breaker considered
- The busbar size and connection orientation (vertical or horizontal).

E

Evaluation and verification of the temperature T_i surrounding the circuit breakers installed in low-voltage switchgear or controlgear assemblies

Requirements for the temperature rise in low-voltage switchgear and controlgear assemblies with associated calculations and tests are specified in IEC 61439-1/2 ^[1].

These two IEC standards lay down the definitions, the service conditions, and the requirements for construction, performance and verification of low-voltage switchgear and controlgear assemblies.

The requirements dedicated to the design, the verifications and the test of the low voltage equipment covered by the scope of IEC 61439-1/2 can be summarized as follows:

- The design of every low-voltage switchgear shall be verified to prove its full compliance with IEC 61439-1/2.
- This is mandatory for all the constructional and performance requirements specified in the standards. Extrapolations or analogies with similar assemblies are not allowed.
- Concerning the temperature rise inside an assembly, type tests are mandatory for rated currents above 1600 A.
- For currents up to and including 1600 A, the verification of temperature rise may be performed by calculation following the method defined in IEC 60890 technical report ^[1].

The IEC 60890 technical report proposes a method to determine the temperature rise of the air inside the low-voltage enclosure without forced ventilation. The method is applicable to enclosed assemblies or partitioned sections of assemblies.

Thus, for low-voltage assemblies with a rated current up to 1600 A, the internal temperature T_i surrounding the circuit breakers and their connections may be evaluated following the method given in IEC 60890 technical report.

According to chapter 10.10.4.3.1 of IEC 61439-1, the method for the evaluation of the temperature T_i surrounding the circuit breaker is applicable if the following conditions are fulfilled:

- The power loss data for all built-in components is available from the component manufacturer.
- There is an approximately even distribution of power losses inside the enclosure;
- The rated current of the circuits of the assembly to be verified shall not exceed 80 % of the rated conventional free air thermal current (I_{th}) if any, or the rated current (I_n) of the switching devices and electrical components included in the circuit.
- The mechanical parts and the installed equipment are arranged so that air circulation is not significantly impeded.

The following data is needed to calculate the temperature rise of the air inside an enclosure:

- Dimensions of the enclosure: height/width/depth;
- Type of installation of the enclosure;
- Design of enclosure, i.e. with or without ventilation openings;
- Number of internal horizontal partitions;
- Effective power loss of equipment installed in the enclosure;
- Effective power losses (P_n) of conductors installed in the enclosure.

Note: Experience shows that for external ambient temperatures up to 35 °C, the internal temperature inside IP 31 low-voltage switchgear and controlgear assemblies does not exceed 60 °C. For degrees of protection above IP 31 the internal temperature reaches 70 °C.

[1] IEC 61439-1: Low-voltage switchgear and controlgear assemblies-Part 1: General rules

IEC 61439-2: Low-voltage switchgear and controlgear assemblies-Part 2: Power switchgear and controlgear assemblies

IEC/TR 60890: A method of temperature-rise verification of low-voltage switchgear and controlgear assemblies by calculation.

Power dissipation (W)

- Total power dissipation is the value measured at In, 50/60 Hz, for a 3-pole or 4-pole breaker, in steady state temperature as per IEC/EN 60947-2.

Type of MasterPacT	MTZ1								MTZ2												MTZ3		
	06 H1 H2	L1	08 H1 H2	L1	10 H1 H2	L1	12 H1 H2 H3	16 H1 H2	08 N1 H2 L1	H1 H2 L1	10 N1 H2 L1	H1 H2 L1	12 N1 H2 L1	H1 H2 L1	16 N1 H2 L1	H1 H2 L1	20 N1 H2 L1	25 H1 H2 L1	32 H1 H2 L1	40 H1 H2 L1	40b H1 H2	50 H1 H2	63 H1 H2
Drawout	55	115	90	140	150	230	250	460	137	100	220	150	330	230	480	390	470	600	670	900	550	950	1200
Fixed	30	45	50	80	80	110	130	220	62	42	100	70	150	100	220	170	250	260	420	650	390	660	1050

Temperature derating

- The table below indicates the maximum current rating, for each connection type, as a function of Ti around the circuit breaker and the busbars. Circuit breakers with mixed connections have the same derating as horizontally connected breakers.
- Ti: temperature around the circuit breaker and its connection.

Drawout																			
Type of MasterPacT		MTZ1 H1 - H2 - L1					MTZ2 N1 - H1 - H2 - H3 - L1										MTZ3 H1 - H2		
		06	08	10	12	16	08	10	12	16	20 ^[2]	20 ^[3]	25	32	40	40	50	63	
Ti ^[1] (°C)		In max. (A)																	
In front or rear horizontal	40	630	800	1000	1250	1600	800	1000	1250	1600	2000	2000	2500	3200	4000	4000	5000	–	
	45					1560									3900				
	50					1520									3100	3800			
	55					1480									3030	3700			
	60					1440					1900				2950	3600			
	65					1400					1830	1950	2450	2880	3500				
	70					1140	1360				1520	1750	1900	2370	2800	3400			
In rear vertical	40	630	800	1000	1250	1600	800	1000	1250	1600	2000	2000	2500	3200	4000	4000	5000	6300	
	45																		
	50																		
	55					1560									3900				
	60					1520									3800			6200	
	65					1480									3700			6000	
	70					1440									3100	3600			5800

Fixed																			
Type of MasterPacT		MTZ1 H1 - H2 - L1					MTZ2 N1 - H1 - H2 - H3 - L1										MTZ3 H1 - H2		
		06	08	10	12	16	08	10	12	16	20 ^[2]	20 ^[3]	25	32	40	40	50	63	
Ti ^[1] (°C)		In max. (A)																	
In front or rear horizontal	40	630	800	1000	1250	1600	800	1000	1250	1600	2000	–	2500	3200	4000	4000	5000	–	
	45																		
	50																		
	55														3900				
	60					1560					1920				3140	3800			
	65					1520					1850				3050	3700			
	70					1480					1770				2960	3600			
In rear vertical	40	630	800	1000	1250	1600	800	1000	1250	1600	2000	–	2500	3200	4000	4000	5000	6300	
	45																		
	50																		
	55																		
	60																		
	65														3900				
	70					1560									3800			6200	

[1] Ti: temperature around the circuit breaker and its connections

[2] Type: N1/H1/H2/H3

[3] Type: L1

 In max. admissible.



Installation rules

Busbar sizing, front or rear horizontal connection

MasterPacT	Max. service current	Ti : 40 °C		Ti : 50 °C		Ti : 60 °C		Ti : 70 °C	
		No. of 5 mm thick bars	No. of 10 mm thick bars	No. of 5 mm thick bars	No. of 10 mm thick bars	No. of 5 mm thick bars	No. of 10 mm thick bars	No. of 5 mm thick bars	No. of 10 mm thick bars
MTZ1 06	400	2b.30 x 5	1b.30 x 10	2b.30 x 5	1b.30 x 10	2b.30 x 5	1b.30 x 10	2b.40 x 5	1b.40 x 10
MTZ1 06	630	2b.40 x 5	1b.40 x 10	2b.40 x 5	1b.40 x 10	2b.50 x 5	1b.50 x 10	2b.50 x 5	1b.60 x 10
MTZ1 08 or MTZ2 08	800	2b.50 x 5	1b.50 x 10	2b.50 x 5	1b.50 x 10	2b.60 x 5	1b.60 x 10	3b.50 x 5	2b.40 x 10
MTZ1 10 or MTZ2 10	1000	2b.60 x 5	1b.60 x 10	2b.60 x 5	1b.60 x 10	2b.80 x 5	2b.40 x 10	3b.60 x 5	2b.50 x 10
MTZ1 12 or MTZ2 12	1250	3b.50 x 5	2b.40 x 10	3b.50 x 5	2b.40 x 10	3b.60 x 5	2b.50 x 10	3b.80 x 5	2b.60 x 10
MTZ1 12 or MTZ2 12	1250	2b.80x5		2b.80x5					
MTZ1 16 or MTZ2 16	1400	3b.60 x 5	2b.50 x 10	3b.60 x 5	2b.50 x 10	3b.80 x 5	2b.60 x 10	3b.80 x 5	3b.50 x 10
MTZ1 16 or MTZ2 16	1600	3b.80 x 5	2b.60 x 10	3b.80 x 5	2b.60 x 10	3b.100 x 5	3b.50 x 10	3b.100 x 5	2b.80 x 10
MTZ2 20	1800	3b.80 x 5	2b.60 x 10	3b.80 x 5	2b.60 x 10	3b.100 x 5	2b.80 x 10	4b.100 x 5	3b.60 x 10
MTZ2 20	2000	3b.100 x 5	2b.80 x 10	3b.100 x 5	2b.80 x 10	4b.100 x 5	3b.60 x 10	4b.100 x 5	2b.100 x 10
MTZ2 25	2200	4b.80 x 5	2b.80 x 10	4b.80 x 5	2b.80 x 10	4b.100 x 5	2b.100 x 10	5b.100 x 5	3b.80 x 10
MTZ2 25	2500	4b.100 x 5	2b.100 x 10	4b.100 x 5	2b.100 x 10	5b.100 x 5	3b.80 x 10	6b.100 x 5	3b.100 x 10
MTZ2 32	2800	5b.100 x 5	3b.80 x 10	5b.100 x 5	3b.80 x 10	6b.100 x 5	3b.100 x 10	7b.100 x 5	4b.80 x 10
MTZ2 32	3000	6b.100 x 5	3b.100 x 10	6b.100 x 5	3b.100 x 10	7b.100 x 5	4b.80 x 10	8b.100 x 5	4b.100 x 10
MTZ2 32	3200	7b.100 x 5	3b.100 x 10	7b.100 x 5	3b.100 x 10	8b.100 x 5	4b.100 x 10		5b.100 x 10
MTZ2 40	3800		4b.100 x 10		4b.100 x 10		5b.100 x 10		6b.100 x 10
MTZ2 40	4000		5b.100 x 10		5b.100 x 10		6b.100 x 10		7b.100 x 10
MTZ3 40	4000		5b.100 x 10		5b.100 x 10		6b.100 x 10		7b.100 x 10
MTZ3 50	4500		6b.100 x 10		6b.100 x 10		7b.100 x 10		8b.100 x 10
MTZ3 50	5000		7b.100 x 10		7b.100 x 10		8b.100 x 10		

With MasterPacT MTZ1, it is recommended to use 50 mm-wide bars (see "Busbar drilling" in page E-12).

DB419228.eps

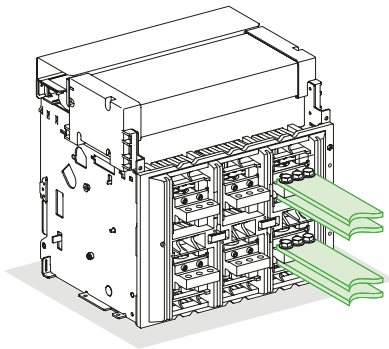

Factors in tables

- Maximum permissible busbar temperature: 100 °C
- Ti: temperature around the circuit breaker and its connections
- Busbar material is unpainted copper

Example

Conditions:

- Drawout version
- Horizontal busbars
- Ti: 50 °C
- Service current: 1800 A

Solution:

For Ti = 50 °C, use an MTZ2 20 which can be connected with three 80 x 5 mm bars or two 60 x 10 mm bars.

Note: For MasterPacT NT/NW, 63 mm wide bars were recommended.

For MasterPacT MTZ, 63 mm wide bars have been replaced by 60 mm wide bars which are more standard. However 63 mm wide bars can be used instead of 60 mm.

Note: The values indicated in these tables are extrapolated from test data and theoretical calculations. These tables are only intended as a guide and cannot replace industrial experience or a temperature rise test.

Installation rules

Busbar sizing rear vertical connection

MasterPacT	Maximum service current	Ti : 40 °C		Ti : 50 °C		Ti : 60 °C		Ti : 70 °C	
		Nb. of 5 mm thick bars	Nb. of 10 mm thick bars	Nb. of 5 mm thick bars	Nb. of 10 mm thick bars	Nb. of 5 mm thick bars	Nb. of 10 mm thick bars	Nb. of 5 mm thick bars	Nb. of 10 mm thick bars
MTZ1 06	400	1b.40 x 5	1b.30 x 10	1b.40 x 5	1b.30 x 10	1b.50 x 5	1b.30 x 10	1b.50 x 5	1b.30 x 10
MTZ1 06	630	1b.60 x 5	1b.30 x 10	1b.60 x 5	1b.30 x 10	2b.40 x 5	1b.40 x 10	2b.40 x 5	1b.40 x 10
MTZ1 08 or MTZ2 08	800	2b.40 x 5	1b.40 x 10	2b.40 x 5	1b.40 x 10	2b.50 x 5	1b.50 x 10	2b.50 x 5	1b.50 x 10
MTZ1 10 or MTZ2 10	1000	2b.50 x 5	1b.50 x 10	2b.50 x 5	1b.50 x 10	2b.60 x 5	1b.60 x 10	2b.60 x 5	1b.60 x 10
MTZ1 12 or MTZ2 12	1250	2b.60 x 5	1b.60 x 10	2b.60 x 5	1b.60 x 10	3b.50 x 5	2b.40 x 10	2b.80 x 5	2b.50 x 10
MTZ1 16 or MTZ2 16	1400	2b.80 x 5	1b.80 x 10	2b.80 x 5	1b.80 x 10	3b.60 x 5	2b.50 x 10	2b.100 x 5	2b.50 x 10
MTZ1 16 or MTZ2 16	1600	3b.60 x 5	2b.50 x 10	3b.60 x 5	2b.50 x 10	2b.100 x 5	2b.60 x 10	3b.80 x 5	2b.60 x 10
MTZ2 20	1800	2b.100 x 5	1b.100 x 10	2b.100 x 5	1b.100 x 10	3b.80 x 5	2b.60 x 10	3b.100 x 5	2b.80 x 10
MTZ2 20	2000	3b.80 x 5	2b.60 x 10	3b.80 x 5	2b.60 x 10	3b.100 x 5	2b.80 x 10	3b.125 x 5	2b.100 x 10
MTZ2 25	2200	3b.100 x 5	2b.60 x 10	3b.100 x 5	2b.60 x 10	4b.80 x 5	2b.80 x 10	4b.100 x 5	2b.100 x 10
MTZ2 25	2500	4b.100 x 5	2b.80 x 10	4b.100 x 5	2b.80 x 10	4b.100 x 5	2b.100 x 10	5b.100 x 5	3b.80 x 10
MTZ2 32	2800	4b.100 x 5	2b.100 x 10	4b.100 x 5	2b.100 x 10	5b.100 x 5	3b.80 x 10	6b.100 x 5	3b.100 x 10
MTZ2 32	3000	5b.100 x 5	3b.80 x 10	5b.100 x 5	3b.80 x 10	6b.100 x 5	3b.80 x 10		3b.100 x 10
MTZ2 32	3200	6b.100 x 5	3b.100 x 10	6b.100 x 5	3b.100 x 10		4b.80 x 10		3b.120 x 10
MTZ2 40	3800		4b.100 x 10		4b.100 x 10		4b.100 x 10		4b.120 x 10
MTZ2 40	4000		4b.100 x 10		4b.100 x 10		5b.100 x 10		5b.120 x 10
MTZ3 40	4000		4b.100 x 10		4b.100 x 10		5b.100 x 10		5b.100 x 10
MTZ3 50	4500		5b.100 x 10		5b.100 x 10		6b.100 x 10		6b.120 x 10
MTZ3 50	5000		6b.100 x 10		6b.100 x 10		7b.100 x 10		7b.120 x 10
MTZ3 63	5700		7b.100 x 10		7b.100 x 10		8b.100 x 10		8b.120 x 10
MTZ3 63	6300		8b.100 x 10		8b.100 x 10				

DB419229 eps

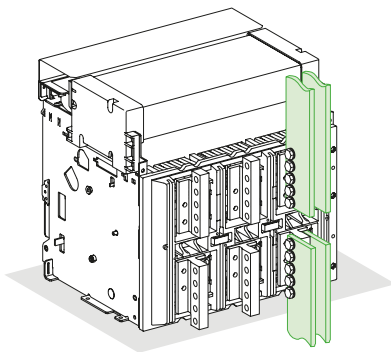

Factors in tables

- Maximum permissible busbar temperature: 100 °C
- Ti: temperature around the circuit breaker and its connections
- Busbar material is unpainted copper

Example

Conditions:

- Drawout version
- Vertical connections
- Ti: 40 °C
- Service current: 1100 A

Solution:

For Ti = 40 °C use an MTZ1 12 or MTZ2 12 which can be connected with two 60 x 5 mm bars or with one 60 x 10 mm bar

Note: For MasterPacT NT/NW, 63 mm wide bars were recommended. For MasterPacT MTZ, 63 mm wide bars have been replaced by 60 mm wide bars which are more standard. However 63 mm wide bars can be used instead of 60 mm.

Note: The values indicated in these tables are extrapolated from test data and theoretical calculations. These tables are only intended as a guide and cannot replace industrial experience or a temperature rise test.



Integrate in a Switchboard

Installation rules

Circuit breaker derating

2000 x 400 x 400 area of outlet vents: 150 cm²

➤ MasterPacT MTZ1 06-16 H1/H2/L1

Type	MTZ1 06 H1/H2/L1		MTZ1 08 H1/H2/L1		MTZ1 10 H1/H2/L1		MTZ1 12 H1/H2		MTZ1 16 H1/H2	
Switchboard composition										
Connection type	≡		≡		≡		≡		≡	
Busbar dimensions (mm)	2b. 40 x 5		2b. 50 x 5		3b. 60 x 5		3b. 60 x 5		3b. 80 x 5	

Ventilated switchboard (→ IP31)				H1/L1		H1/L1					
T _a = 35 °C	4										
	3	630	630	800	800	1000/1000	1000/1000	1250	1250	1400	1520
	2										
T _a = 45 °C	4										
	3	630	630	800	800	1000/950	1000/1000	1250	1250	1330	1440
	2										
T _a = 55 °C	4										
	3	630	630	800	800	1000/890	1000/960	1200	1250	1250	1340
	2										

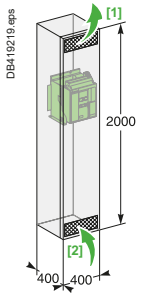

[1] Area of outlet vents: 150 cm²
 [2] Area of inlet vents: 150 cm²

Non ventilated switchboard (→ IP54)											
T _a = 35 °C	4										
	3	630	630	800	800	1000/960	1000/1000	1250	1250	1330	1400
	2										
T _a = 45 °C	4										
	3	630	630	800	800	1000/910	1000/980	1220	1250	1260	1330
	2										
T _a = 55 °C	4										
	3	630	630	800	800	1000/860	1000/930	1150	1230	1200	1260
	2										

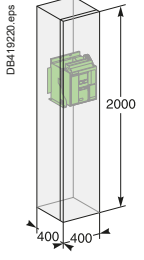

Factors in tables

- Switchboard dimensions
- Number of circuit breakers installed
- Type of breaker connections
- Drawout versions
- Ambient temperature outside the switchboard: T_a (IEC 61439-1)

Factors affecting switchboard design

- The temperature around the circuit breaker and its connections is used to define the type of circuit breaker to be used and its connection arrangement.
- Vents at the top and bottom of the cubicles considerably reduce the temperature inside the switchboard, but must be designed so as to respect the degree of protection provided by the enclosure. For weatherproof heavy-duty cubicles, a forced ventilation system may be required.
- The heat dissipated by the devices installed in the switchboard is the heat dissipated by the circuit breakers under normal conditions (service current).
- The size of the enclosure determines the volume for cooling calculations.
- Switchboard installation mode: free-standing, against a wall, etc.
- Horizontal partitions can obstruct air circulation within the enclosure.

Note: The values indicated in these tables are extrapolated from test data and theoretical calculations. These tables are only intended as a guide and cannot replace industrial experience or a temperature rise test. The values indicated for the cross-sectional area of the vents should be considered as general indications only, given that the thermal performance of a switchboard with natural ventilation depends on many parameters, including shape, porosity, and location of vents and air flow within the switchboard.

2300 x 1100 x 500 area of outlet vents: 300 cm²

> MasterPacT MTZ1 06-08 H1/H2/L1

Type	MTZ1 06 H1/H2/L1						MTZ1 08 H1/H2/L1				
Switchboard composition											
Connection type											
Busbar dimensions (mm)	2b. 40 x 5						2b. 50 x 5				

Ventilated switchboard (→ IP31)		DB411921.eps														
T _a = 35 °C	5					630	630							800		
	4					630	630	630						800	800	
	3					630	630	630	630					800	800	800
	2	630	630	630	630	630	630	630			800	800	800	800	800	
	1							630								
T _a = 45 °C	5					630	630							800		
	4					630	630	630						800	800	
	3					630	630	630	630					800	800	800
	2	630	630	630	630	630	630	630			800	800	800	800	800	
	1							630								
T _a = 55 °C	5					630	630							800		
	4					630	630	630						800	800	
	3					630	630	630	630					800	800	800
	2	630	630	630	630	630	630	630			800	800	800	800	800	
	1							630								

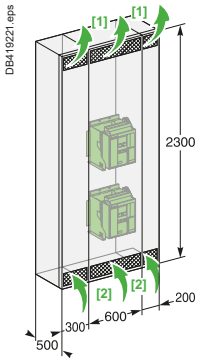

[1] Area of outlet vents: 300 cm²

[2] Area of inlet vents: 300 cm²

Non ventilated switchboard (→ IP54)		DB411922.eps														
T _a = 35 °C	5					630	630							800		
	4					630	630	630						800	800	
	3					630	630	630	630					800	800	800
	2	630	630	630	630	630	630	630			800	800	800	800	800	
	1							630								
T _a = 45 °C	5					630	630							800		
	4					630	630	630						800	800	
	3					630	630	630	630					800	800	800
	2	630	630	630	630	630	630	630			800	800	800	800	800	
	1							630								
T _a = 55 °C	5					630	630							800		
	4					630	630	630						800	800	
	3					630	630	630	630					800	800	800
	2	630	630	630	630	630	630	630			800	800	800	800	800	
	1							630								

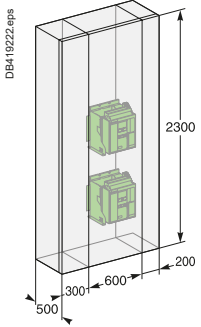

Factors in tables

- Switchboard dimensions
- Number of circuit breakers installed
- Type of breaker connections
- Drawout versions
- Ambient temperature outside the switchboard: T_a (IEC 61439-1)

Factors affecting switchboard design

- The temperature around the circuit breaker and its connections is used to define the type of circuit breaker to be used and its connection arrangement.
- Vents at the top and bottom of the cubicles considerably reduce the temperature inside the switchboard, but must be designed so as to respect the degree of protection provided by the enclosure. For weatherproof heavy-duty cubicles, a forced ventilation system may be required.
- The heat dissipated by the devices installed in the switchboard is the heat dissipated by the circuit breakers under normal conditions (service current).
- The size of the enclosure determines the volume for cooling calculations.
- Switchboard installation mode: free-standing, against a wall, etc.
- Horizontal partitions can obstruct air circulation within the enclosure.

Note: The values indicated in these tables are extrapolated from test data and theoretical calculations. These tables are only intended as a guide and cannot replace industrial experience or a temperature rise test. The values indicated for the cross-sectional area of the vents should be considered as general indications only, given that the thermal performance of a switchboard with natural ventilation depends on many parameters, including shape, porosity, and location of vents and air flow within the switchboard.

Integrate in a Switchboard

Installation rules

Circuit breaker derating

2300 x 1100 x 500 area of outlet vents: 300 cm²

➤ MasterPacT MTZ1 10-16 H1/H2/L1

Type	MTZ1 10 H1/H2/L1				MTZ1 12 H1/H2				MTZ1 16 H1/H2				
Switchboard composition													
Connection type													
Busbar dimensions (mm)	3b. 60 x 5				3b. 60 x 5				3b. 80 x 5				
Ventilated switchboard (→ IP31)	5 H1/L1	H1/L1	H1/L1	H1/L1	3b. 50 x 5				3b. 60 x 5				
	$T_a = 35\text{ °C}$	5											
		4			1000/1000				1250				
		3			1000/1000	1000/1000			1250	1250		1500	
		2	1000/1000	1000/1000	1000/1000	1000/1000		1250	1250	1250	1250	1460	1600
	$T_a = 45\text{ °C}$	5											
		4			1000/1000				1250				
		3			1000/1000	1000/1000			1250	1250			1420
		2	1000/960	1000/1000	1000/1000	1000/1000		1250	1250	1250	1250	1400	1500
	$T_a = 55\text{ °C}$	5											
		4			1000/920				1250				
		3			1000/950	1000/930			1250	1250			1330
		2	1000/900	1000/1000	1000/970	1000/950		1250	1250	1250	1250	1300	1400
	$T_a = 35\text{ °C}$	5											
		4			1000/950				1250				
		3			1000/1000	1000/960			1250	1250			1370
		2	1000/1000	1000/1000	1000/1000	1000/970		1250	1250	1250	1250	1400	1500
	$T_a = 45\text{ °C}$	5											
		4			1000/900				1180				
		3			1000/950	1000/910			1250	1190			1300
		2	1000/950	1000/1000	1000/960	1000/930		1250	1250	1250	1220	1350	1430
	$T_a = 55\text{ °C}$	5											
		4			1000/850				1120				
		3			1000/900	1000/860			1200	1130			1210
		2	1000/880	1000/970	1000/910	1000/870		1210	1250	1210	1150	1250	1350

[1] Area of outlet vents: 300 cm²
 [2] Area of inlet vents: 300 cm²

Non ventilated switchboard (→ IP54)

Factors in tables

- Switchboard dimensions
- Number of circuit breakers installed
- Type of breaker connections
- Drawout versions
- Ambient temperature outside the switchboard: T_a (IEC 61439-1)

Factors affecting switchboard design

- The temperature around the circuit breaker and its connections is used to define the type of circuit breaker to be used and its connection arrangement.
- Vents at the top and bottom of the cubicles considerably reduce the temperature inside the switchboard, but must be designed so as to respect the degree of protection provided by the enclosure. For weatherproof heavy-duty cubicles, a forced ventilation system may be required.
- The heat dissipated by the devices installed in the switchboard is the heat dissipated by the circuit breakers under normal conditions (service current).
- The size of the enclosure determines the volume for cooling calculations.
- Switchboard installation mode: free-standing, against a wall, etc.
- Horizontal partitions can obstruct air circulation within the enclosure.

Note: The values indicated in these tables are extrapolated from test data and theoretical calculations. These tables are only intended as a guide and cannot replace industrial experience or a temperature rise test. The values indicated for the cross-sectional area of the vents should be considered as general indications only, given that the thermal performance of a switchboard with natural ventilation depends on many parameters, including shape, porosity, and location of vents and air flow within the switchboard.

2300 x 800 x 900 area of outlet vents: 350 cm²

> MasterPacT MTZ2 08-10 N1/H1/H2/L1

Type	MTZ2 08 N1/H1/H2/L1					MTZ2 10 N1/H1/H2/L1			
Switchboard composition									
Connection type									
Busbar dimensions (mm)	2b. 50 x 5					3b. 60 x 5 2b. 60 x 5			

Ventilated switchboard (→ IP31)		MTZ2 08 N1/H1/H2/L1					MTZ2 10 N1/H1/H2/L1				
	$T_a = 35\text{ °C}$	4				800					
		3				800	800				1000
		2			800	800	800			1000	1000
		1	800	800	800	800	800		1000	1000	1000
	$T_a = 45\text{ °C}$	4				800					
		3				800	800				1000
		2			800	800	800			1000	1000
		1	800	800	800	800	800		1000	1000	1000
	$T_a = 55\text{ °C}$	4				800					
		3				800	800				1000
		2			800	800	800			1000	1000
		1	800	800	800	800	800		1000	1000	1000

[1] Area of outlet vents: 350 cm².
 [2] Area of inlet vents: 350 cm².

Non ventilated switchboard (→ IP54)		MTZ2 08 N1/H1/H2/L1					MTZ2 10 N1/H1/H2/L1				
	$T_a = 35\text{ °C}$	4				800					
		3				800	800				1000
		2			800	800	800			1000	1000
		1	800	800	800	800	800		1000	1000	1000
	$T_a = 45\text{ °C}$	4				800					
		3				800	800				1000
		2			800	800	800			1000	1000
		1	800	800	800	800	800		1000	1000	1000
	$T_a = 55\text{ °C}$	4				800					
		3				800	800				1000
		2			800	800	800			1000	1000
		1	800	800	800	800	800		1000	1000	1000

Factors in tables

- Switchboard dimensions
- Number of circuit breakers installed
- Type of breaker connections
- Drawout versions
- Ambient temperature outside the switchboard: T_a (IEC 61439-1)

Factors affecting switchboard design

- The temperature around the circuit breaker and its connections is used to define the type of circuit breaker to be used and its connection arrangement.
- Vents at the top and bottom of the cubicles considerably reduce the temperature inside the switchboard, but must be designed so as to respect the degree of protection provided by the enclosure. For weatherproof heavy-duty cubicles, a forced ventilation system may be required.
- The heat dissipated by the devices installed in the switchboard is the heat dissipated by the circuit breakers under normal conditions (service current).
- The size of the enclosure determines the volume for cooling calculations.
- Switchboard installation mode: free-standing, against a wall, etc.
- Horizontal partitions can obstruct air circulation within the enclosure.

Note: The values indicated in these tables are extrapolated from test data and theoretical calculations. These tables are only intended as a guide and cannot replace industrial experience or a temperature rise test. The values indicated for the cross-sectional area of the vents should be considered as general indications only, given that the thermal performance of a switchboard with natural ventilation depends on many parameters, including shape, porosity, and location of vents and air flow within the switchboard.

Integrate in a Switchboard

Installation rules

Circuit breaker derating

2300 x 800 x 900 area of outlet vents: 350 cm²

➤ MasterPacT MTZ2 12-16 N1/H1/H2/L1

Type	MTZ2 12 N1	MTZ2 12 H1/H2/L1	MTZ2 16 N1	MTZ2 16 H1/H2/L1
Switchboard composition				
Connection type				
Busbar dimensions (mm)	3b. 60 x 5 3b. 50 x 5	3b. 60 x 5 3b. 50 x 5	3b. 80 x 5 3b. 60 x 5	3b. 80 x 5 3b. 60 x 5

Ventilated switchboard (→ IP31)

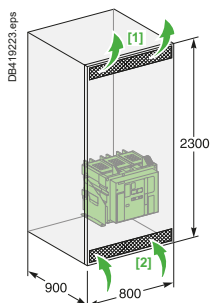

Temperature (T _a)	4	3	2	1	4	3	2	1	4	3	2	1	4	3	2	1	
T _a = 35 °C			1250	1250	1250	1250	1250	1250	1250	1250	1250	1250	1550	1600	1600	1600	1600
T _a = 45 °C			1250	1250	1250	1250	1250	1250	1250	1250	1250	1250	1470	1600	1600	1600	1600
T _a = 55 °C			1250	1250	1250	1250	1250	1250	1250	1250	1250	1250	1380	1500	1500	1520	1600

[1] Area of outlet vents: 350 cm²

[2] Area of inlet vents: 350 cm²

Non ventilated switchboard (→ IP54)

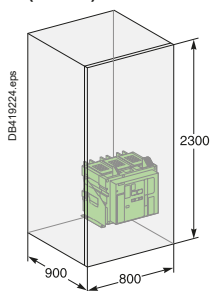

Temperature (T _a)	4	3	2	1	4	3	2	1	4	3	2	1	4	3	2	1	
T _a = 35 °C			1240	1250	1250	1250	1250	1250	1250	1250	1250	1250	1440	1550	1550	1600	1600
T _a = 45 °C			1170	1210	1210	1250	1250	1250	1250	1250	1250	1250	1360	1470	1470	1500	1600
T _a = 55 °C			1100	1140	1170	1250	1250	1250	1250	1250	1250	1250	1280	1380	1380	1400	1520

Factors in tables

- Switchboard dimensions
- Number of circuit breakers installed
- Type of breaker connections
- Drawout versions
- Ambient temperature outside the switchboard: T_a (IEC 61439-1)

Factors affecting switchboard design

- The temperature around the circuit breaker and its connections is used to define the type of circuit breaker to be used and its connection arrangement.
- Vents at the top and bottom of the cubicles considerably reduce the temperature inside the switchboard, but must be designed so as to respect the degree of protection provided by the enclosure. For weatherproof heavy-duty cubicles, a forced ventilation system may be required.
- The heat dissipated by the devices installed in the switchboard is the heat dissipated by the circuit breakers under normal conditions (service current).
- The size of the enclosure determines the volume for cooling calculations.
- Switchboard installation mode: free-standing, against a wall, etc.
- Horizontal partitions can obstruct air circulation within the enclosure.

Note: The values indicated in these tables are extrapolated from test data and theoretical calculations. These tables are only intended as a guide and cannot replace industrial experience or a temperature rise test. The values indicated for the cross-sectional area of the vents should be considered as general indications only, given that the thermal performance of a switchboard with natural ventilation depends on many parameters, including shape, porosity, and location of vents and air flow within the switchboard.

2300 x 800 x 900 area of outlet vents: 350 cm²

> MasterPacT MTZ2 20-40 N1/H1/H2/H3/L1

Type	MTZ2 20 N1/H1/H2/H3	MTZ2 20 L1	MTZ2 25 H1/H2/H3	MTZ2 32 H1/H2/H3	MTZ2 40 H1/H2/H3
Switchboard composition					

Connection type	≡ ≡ ≡	≡ ≡ ≡	≡ ≡ ≡	≡ ≡ ≡	≡ ≡ ≡	≡ ≡ ≡	≡ ≡ ≡	≡ ≡ ≡	≡ ≡ ≡	≡ ≡ ≡	≡ ≡ ≡
Busbar dimensions (mm)	3b. 100 x 5	3b. 100 x 5	3b. 100 x 5	4b. 100 x 5	3b. 100 x 10	4b. 100 x 10	3b. 100 x 10	4b. 100 x 10	3b. 100 x 10	4b. 100 x 10	4b. 100 x 10

Ventilated switchboard (→ IP31)

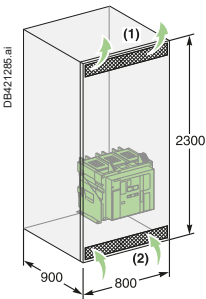

T _a = 35 °C	Ventilated switchboard (→ IP31)												
	4	3	2	1	4	3	2	1	4	3	2	1	
			2000				1830						
	2000	2000	2000	2000	2000	2000	2000	2375	2500	3040	3200	3320	3700
	4	3	2000				1750						
	2000	2000	2000	1810	1960	1920	2250	2380	2880	3100	3160	3500	
	4	3	2000				1640						
	2000	2000	2000	1700	1850	1800	2100	2250	2690	2900	2960	3280	

[1] Area of outlet vents: 350 cm².
 [2] Area of inlet vents: 350 cm².

Non ventilated switchboard (→ IP54)

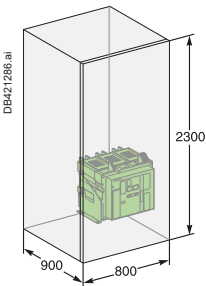

T _a = 35 °C	Non ventilated switchboard (→ IP54)											
	4	3	2	1	4	3	2	1	4	3	2	1
			2000				1750					
	2000	2000	2000	1800	1900	1890	2125	2275	2650	2850	3040	3320
	4 <td>3 <td>1900</td> <td></td> <td></td> <td></td> <td>1660</td> <td></td> <td></td> <td></td> <td></td> <td></td> </td>	3 <td>1900</td> <td></td> <td></td> <td></td> <td>1660</td> <td></td> <td></td> <td></td> <td></td> <td></td>	1900				1660					
	2000	1960	1960	1680	1810	1800	2000	2150	2550	2700	2880	3120
	4 <td>3 <td>1780</td> <td></td> <td></td> <td></td> <td>1550</td> <td></td> <td></td> <td></td> <td></td> <td></td> </td>	3 <td>1780</td> <td></td> <td></td> <td></td> <td>1550</td> <td></td> <td></td> <td></td> <td></td> <td></td>	1780				1550					
	2000	1920	1920	1590	1700	1700	1900	2020	2370	2530	2720	2960

Factors in tables

- Switchboard dimensions
- Number of circuit breakers installed
- Type of breaker connections
- Drawout versions
- Ambient temperature outside the switchboard: T_a (IEC 61439-1)

Factors affecting switchboard design

- The temperature around the circuit breaker and its connections is used to define the type of circuit breaker to be used and its connection arrangement.
- Vents at the top and bottom of the cubicles considerably reduce the temperature inside the switchboard, but must be designed so as to respect the degree of protection provided by the enclosure. For weatherproof heavy-duty cubicles, a forced ventilation system may be required.
- The heat dissipated by the devices installed in the switchboard is the heat dissipated by the circuit breakers under normal conditions (service current).
- The size of the enclosure determines the volume for cooling calculations.
- Switchboard installation mode: free-standing, against a wall, etc.
- Horizontal partitions can obstruct air circulation within the enclosure.

Note: The values indicated in these tables are extrapolated from test data and theoretical calculations. These tables are only intended as a guide and cannot replace industrial experience or a temperature rise test. The values indicated for the cross-sectional area of the vents should be considered as general indications only, given that the thermal performance of a switchboard with natural ventilation depends on many parameters, including shape, porosity, and location of vents and air flow within the switchboard.

Integrate in a Switchboard

Installation rules

Circuit breaker derating

2300 x 1400 x 1500 area of outlet vents: 500 cm²

> MasterPacT MTZ3 40-63 H1/H2

Type	MTZ3 40 H1/H2	MTZ3 50 H1/H2	MTZ3 63 H1/H2
Switchboard composition			
Connection type			
Busbar dimensions (mm)	5b. 100 x 10	7b. 100 x 10	8b. 100 x 10
Ventilated switchboard (→ IP31)			
Non ventilated switchboard (→ IP54)			
Area of outlet vents: 500 cm²	[1]		
Area of inlet vents: 500 cm²	[2]		
T_a = 35 °C	4 3 2 4000 4000 1	4 3 2 4700 5000 1	4 3 2 5850 1
T_a = 45 °C	4 3 2 4000 4000 1	4 3 2 4450 4850 1	4 3 2 5670 1
T_a = 55 °C	4 3 2 4000 4000 1	4 3 2 4200 4600 1	4 3 2 5350 1
T_a = 35 °C	4 3 2 4000 4000 1	4 3 2 4350 4650 1	4 3 2 5290 1
T_a = 45 °C	4 3 2 4000 4000 1	4 3 2 4100 4400 1	4 3 2 5040 1
T_a = 55 °C	4 3 2 3840 3840 1	4 3 2 3850 4150 1	4 3 2 4730 1

Factors in tables

- Switchboard dimensions
- Number of circuit breakers installed
- Type of breaker connections
- Drawout versions
- Ambient temperature outside the switchboard: T_a (IEC 61439-1).

Factors affecting switchboard design

- The temperature around the circuit breaker and its connections is used to define the type of circuit breaker to be used and its connection arrangement.
- Vents at the top and bottom of the cubicles considerably reduce the temperature inside the switchboard, but must be designed so as to respect the degree of protection provided by the enclosure. For weatherproof heavy-duty cubicles, a forced ventilation system may be required.
- The heat dissipated by the devices installed in the switchboard is the heat dissipated by the circuit breakers under normal conditions (service current).
- The size of the enclosure determines the volume for cooling calculations.
- Switchboard installation mode: free-standing, against a wall, etc.
- Horizontal partitions can obstruct air circulation within the enclosure.

Note: The values indicated in these tables are extrapolated from test data and theoretical calculations. These tables are only intended as a guide and cannot replace industrial experience or a temperature rise test. The values indicated for the cross-sectional area of the vents should be considered as general indications only, given that the thermal performance of a switchboard with natural ventilation depends on many parameters, including shape, porosity, and location of vents and air flow within the switchboard.

Dimensions

MasterPacT MTZ1 fixed 3/4-pole devices

Dimensions

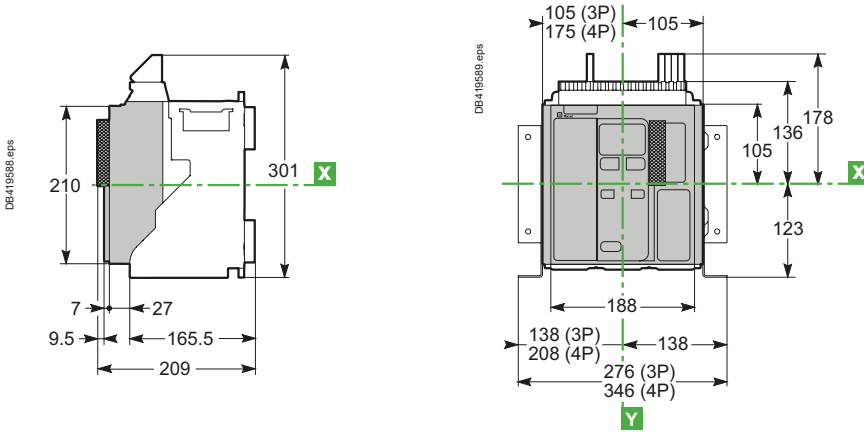

Mounting on base plate or rails

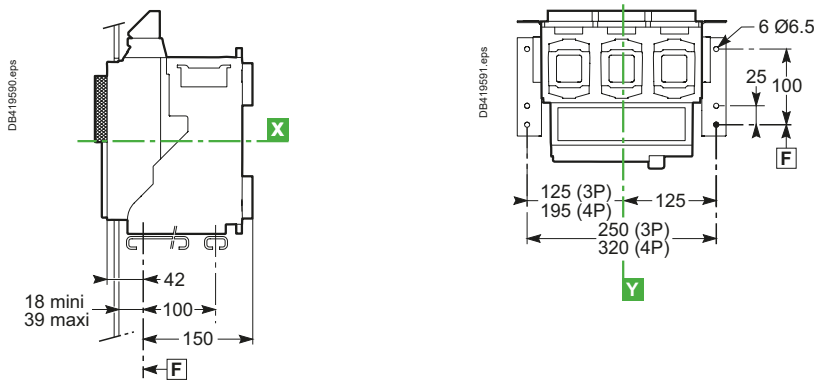

Mounting detail

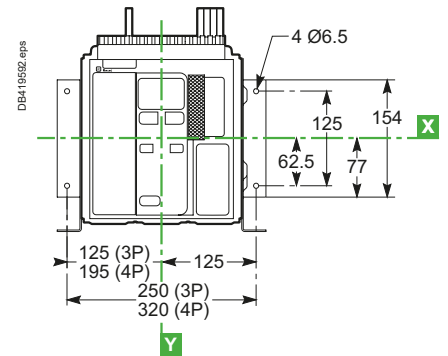

Clearance distances

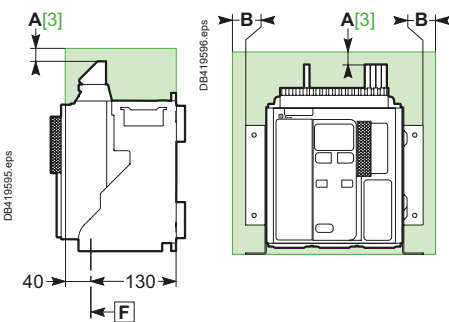

Door cutout

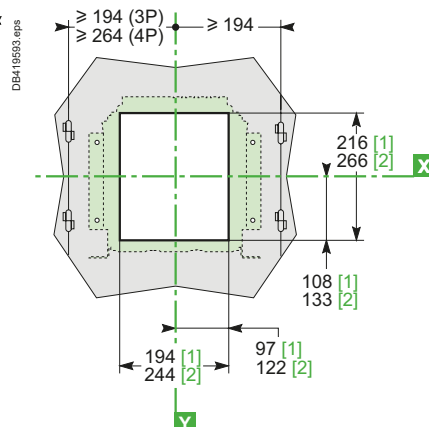

Rear panel cutout

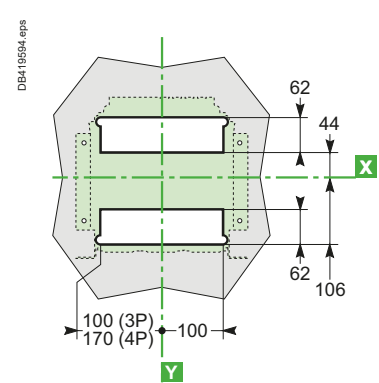

	Insulated parts	Metal parts	Energized parts
A	0	0	100
B	0	0	60

[1] Without escutcheon.

[2] With escutcheon.

[3] An overhead clearance of 50 mm is required to remove the arc chutes. An overhead clearance of 20 mm is required to remove the terminal block.

Note: [F] Datum, circuit breaker or chassis mounting hole.

[X] and [Y] are the symmetry planes for a 3-pole device.



Dimensions

MasterPacT MTZ1 fixed 3/4-pole devices

Connections

Horizontal rear connection

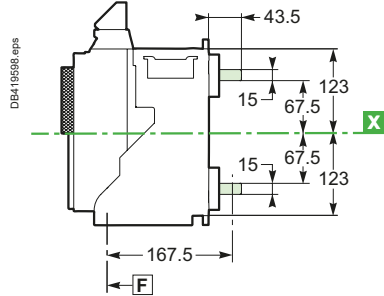
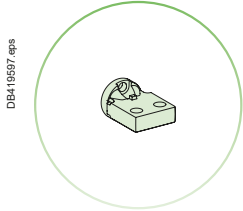

Details

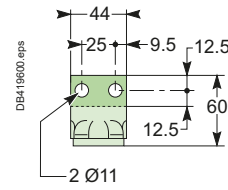
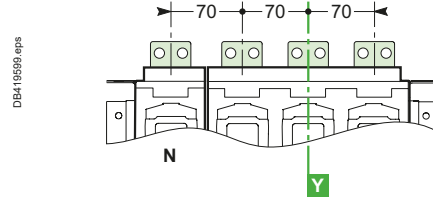

Vertical rear connection

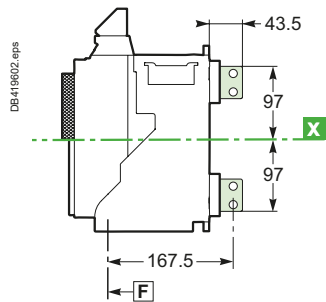
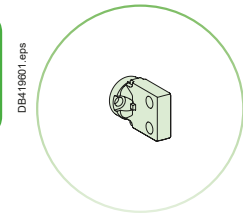

Details

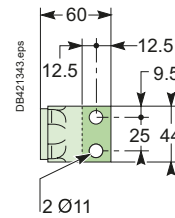
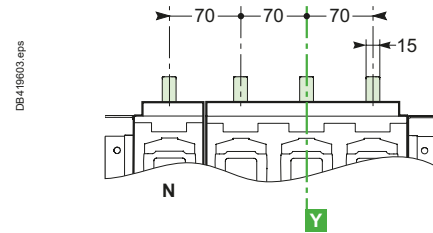

Front connection

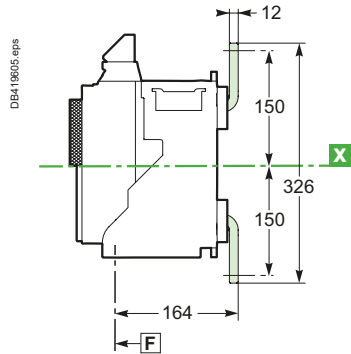
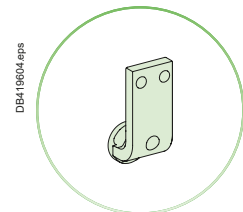

Details

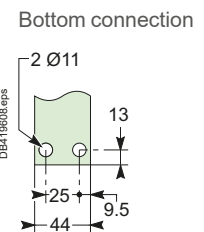
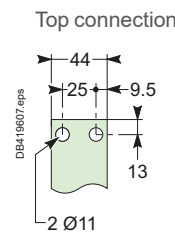
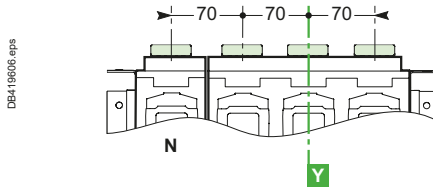

Notes: Recommended connection screws: M10 Class 8.8.
Tightening torque: 50 Nm with contact washer.

Dimensions

MasterPacT MTZ1 fixed 3/4-pole devices

Connections

Front connection with spreaders

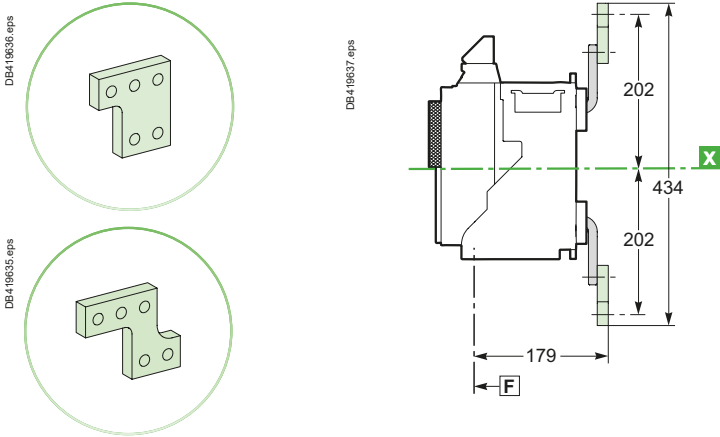

Details

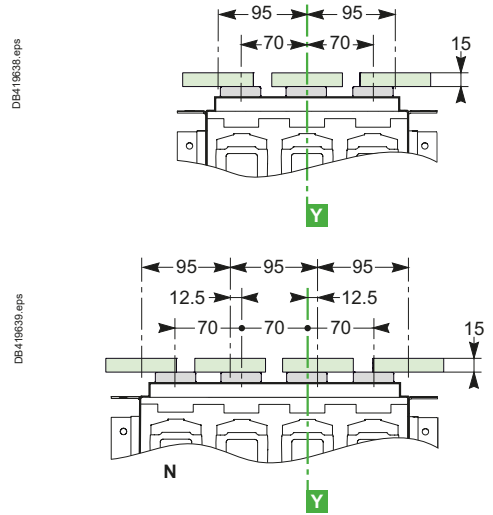

Rear connection with spreaders

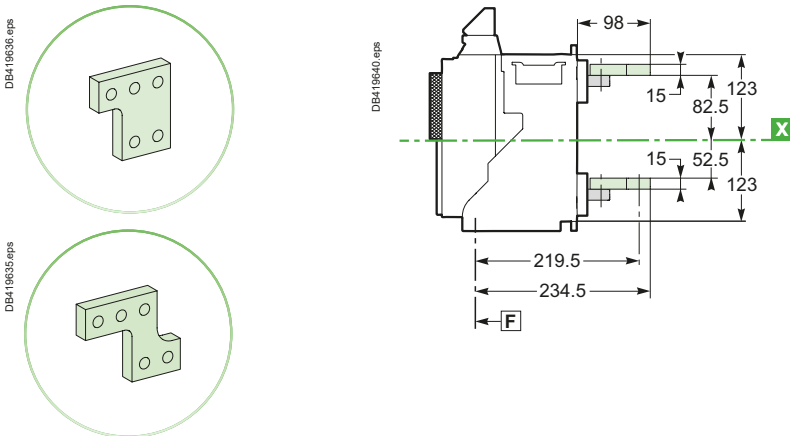

Details

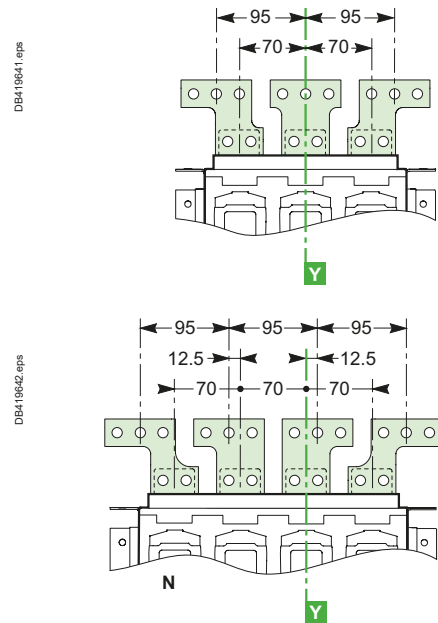

Spreader detail

Middle left or middle right spreader for 4P

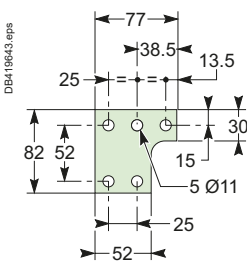

Middle spreader for 3P

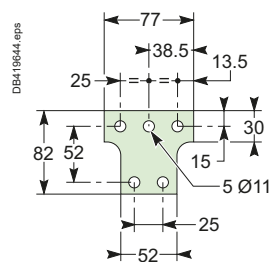

Left or right spreader for 4P

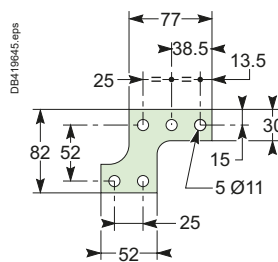

Left or right spreader for 3P

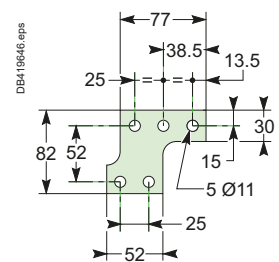

Note: **F** Datum, circuit breaker or chassis mounting hole.
X and **Y** are the symmetry planes for a 3-pole device.



Dimensions

MasterPacT MTZ1 fixed 3/4-pole devices

Connections

Front connection via vertical connection adapters oriented to the rear

Details

DB419647.eps

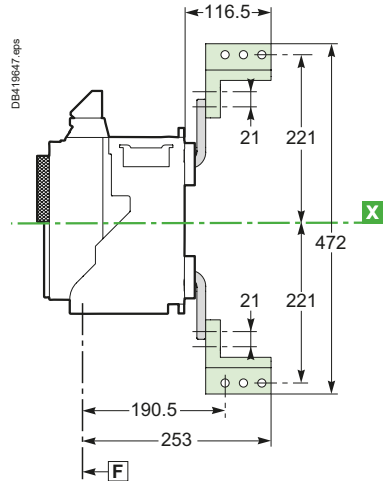
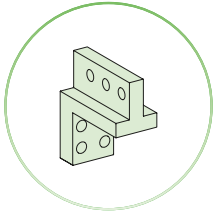

DB419648.eps

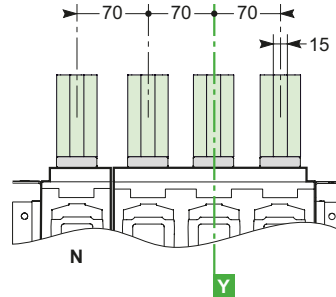

DB419649.eps

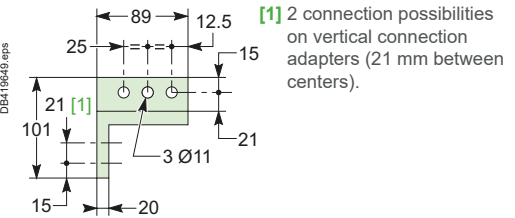

E

Front connection via vertical connection adapters fitted with cable-lug adapters oriented to the rear

Details

DB419650.eps

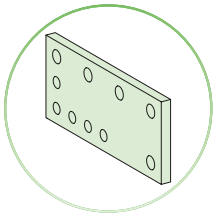

Notes: Recommended connection screws: M10 Class 8.8. Tightening torque: 50 Nm with contact washer.

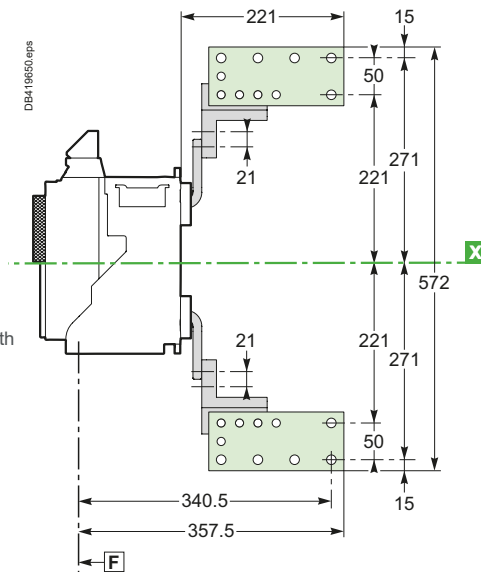

DB419651.eps

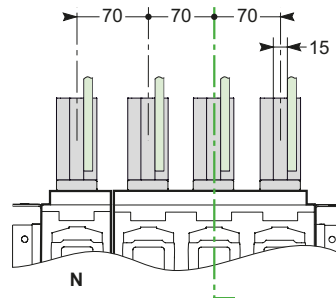

DB419652.eps

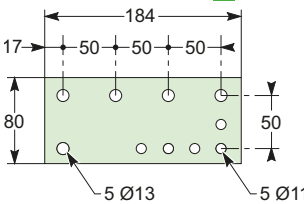

Spacers (kit 04691)

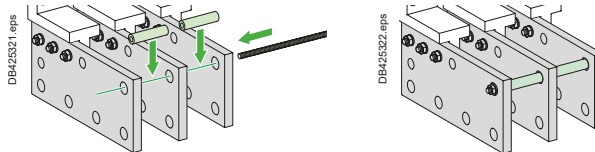

Spacers must be mounted between the cable lug adapters to withstand the electrodynamic stresses in the event of a short-circuit.

Dimensions

MasterPacT MTZ1 fixed 3/4-pole devices

Connections

Front connection via vertical connection adapters oriented to the front

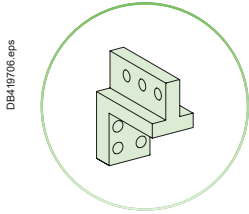

Notes: For this connection the arc chute screen is mandatory.

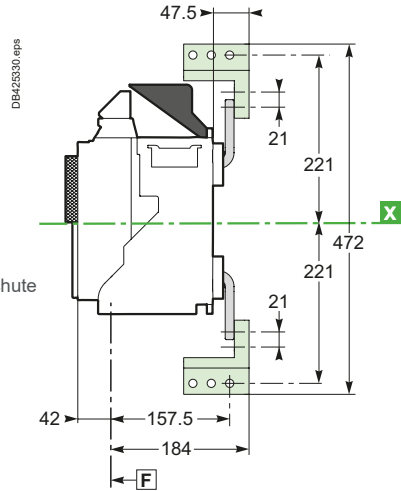

Details

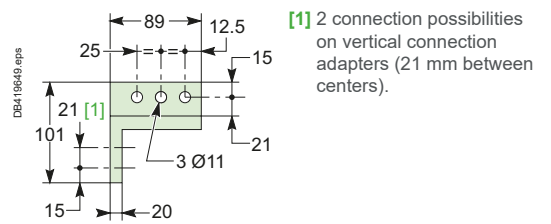
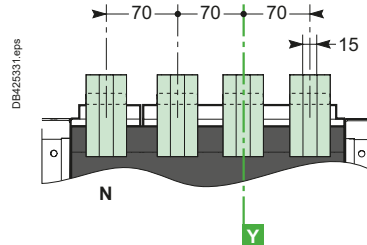

Front connection via vertical connection adapters fitted with cable-lug adapters oriented to the front

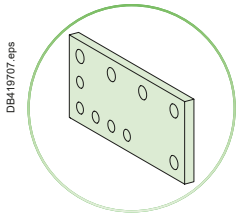

Notes:

- For this connection the arc chute screen is mandatory.
- Third party cable-lug adapters mounted on front-facing vertical connection adapters above arc chutes must not exceed the maximum distance **A**.
- Recommended connection screws: M10 Class 8.8. Tightening torque: 50 Nm with contact washer.

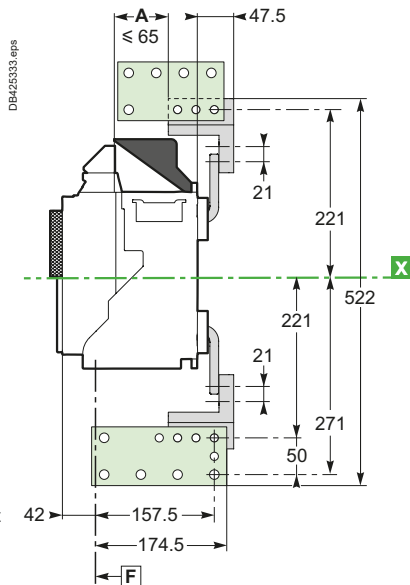

Details

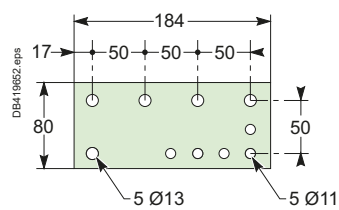
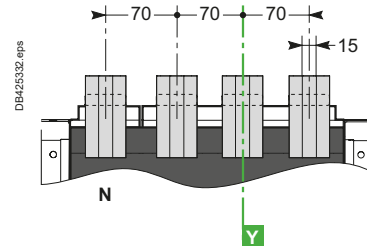

Spacers (kit 04691)

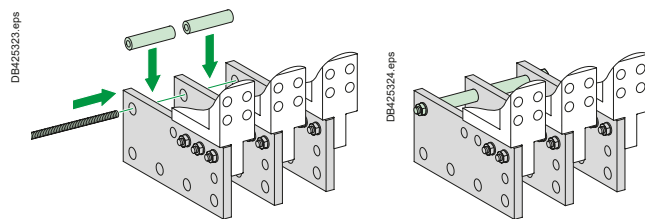

Spacers must be mounted between the cable lug adapters to withstand the electrodynamic stresses in the event of a short-circuit.



Dimensions

MasterPacT MTZ1 drawout 3/4-pole devices

Dimensions

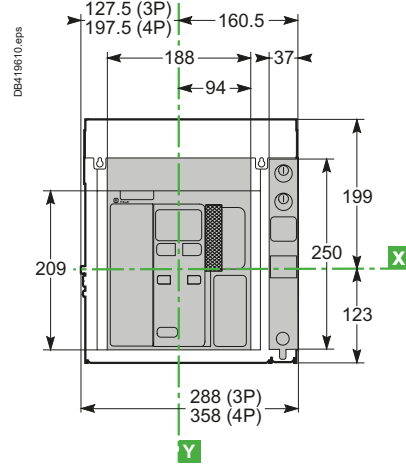
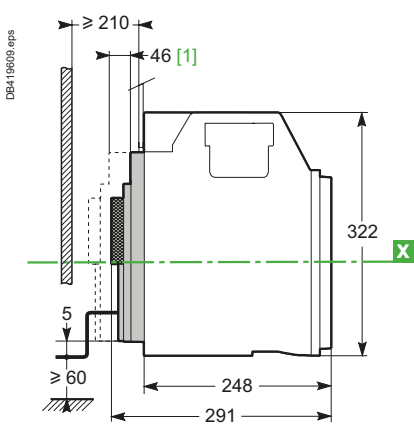

Clearance distances

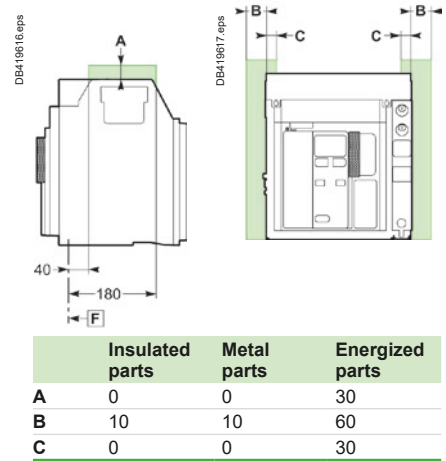

Mounting on base plate or rails

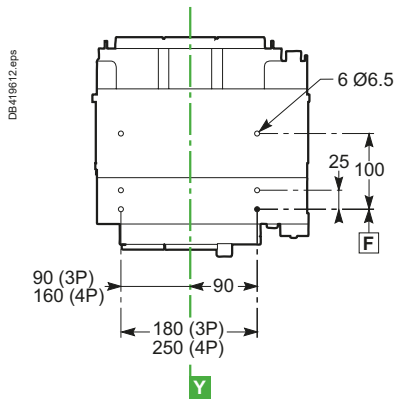
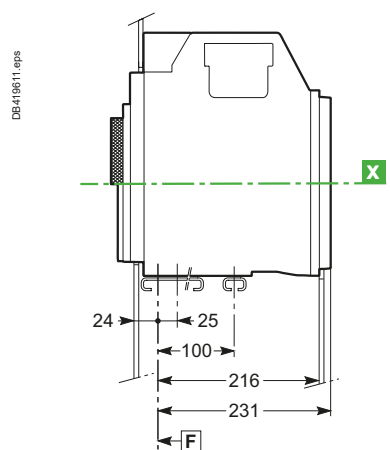

Mounting detail

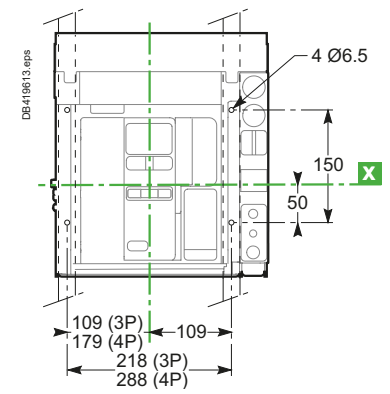

Door cutout without escutcheon

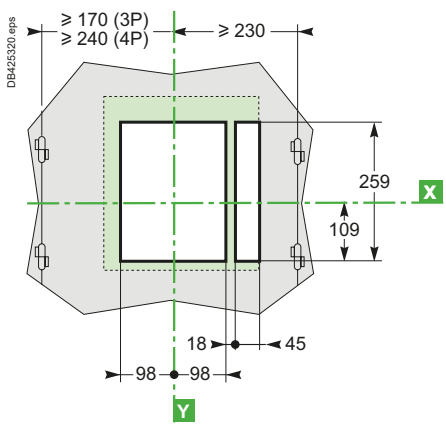

Door cutout with escutcheon

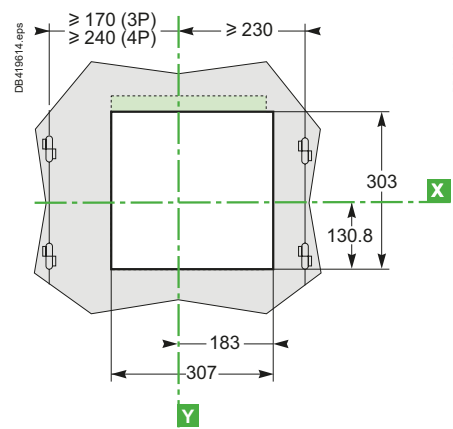

Rear panel cutout

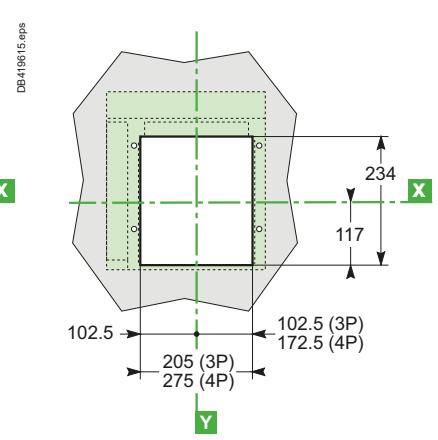

[1] Disconnected position.

Note: F Datum, circuit breaker or chassis mounting hole.

X and Y are the symmetry planes for a 3-pole device.

Dimensions

MasterPacT MTZ1 drawout 3/4-pole devices

Connections

Horizontal rear connection

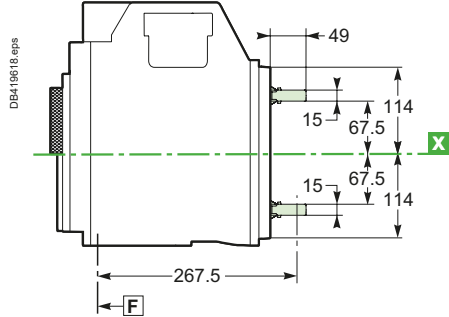
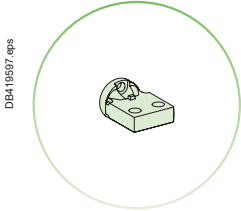

Details

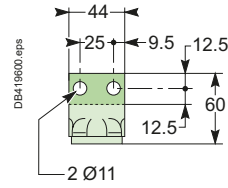
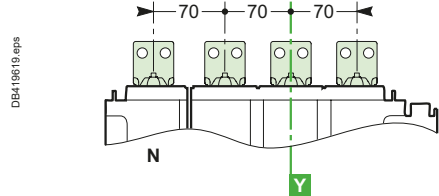

Vertical rear connection

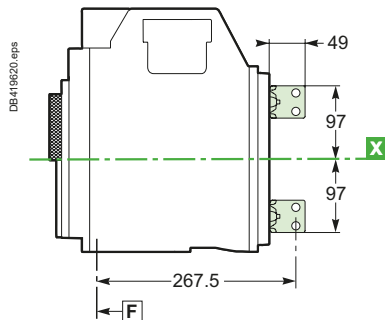
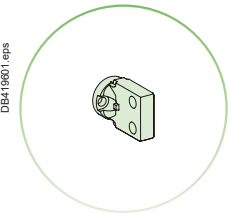

Details

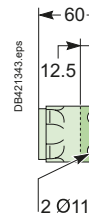
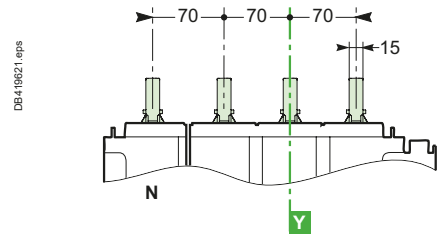

Front connection

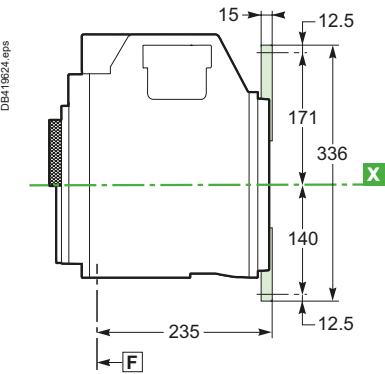
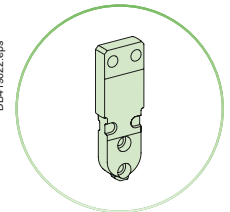

Details

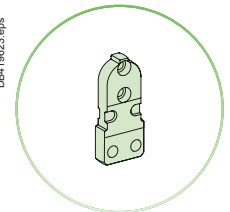
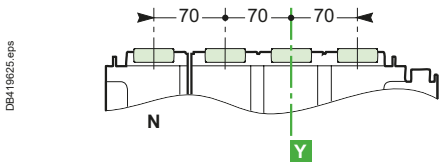

Top connection

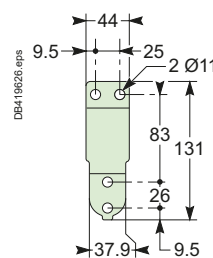

Bottom connection

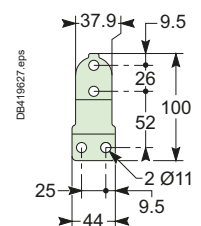

Notes: Recommended connection screws: M10 Class 8.8.
Tightening torque: 50 Nm with contact washer.



Dimensions

MasterPacT MTZ1 drawout 3/4-pole devices

Connections

Front connection with spreaders

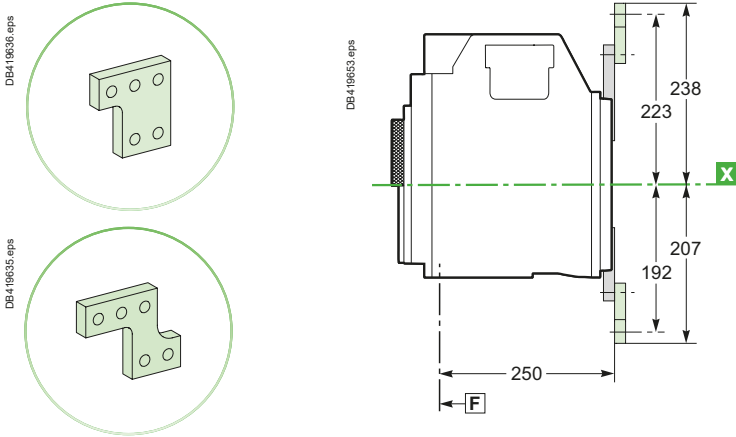

Details

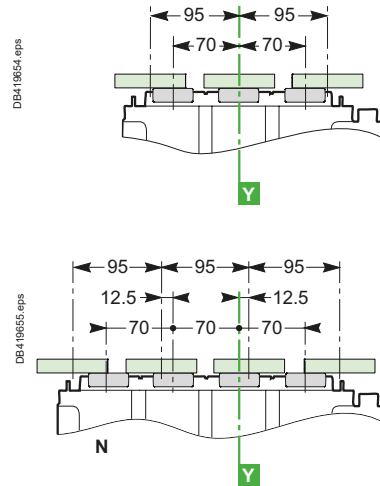

Spreader detail

Middle left or middle right spreader for 4P

Middle spreader for 3P

Left or right spreader for 4P

Left or right spreader for 3P

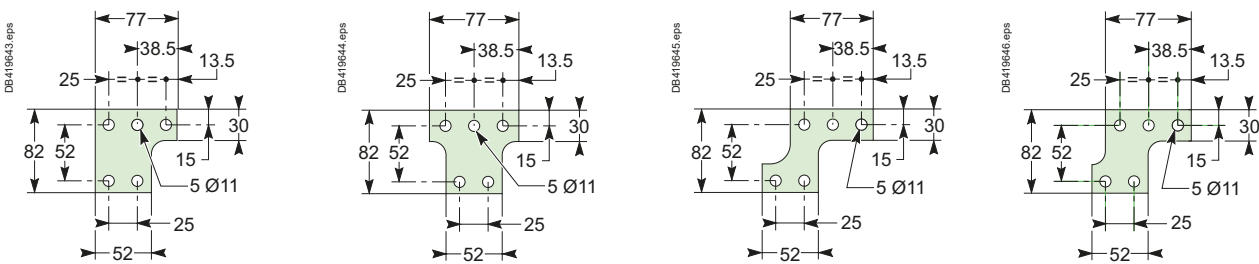

Note: **F** Datum, circuit breaker or chassis mounting hole.
X and **Y** are the symmetry planes for a 3-pole device.

E

Dimensions

MasterPacT MTZ1 drawout 3/4-pole devices

Connections

Vertical connection adapters fitted with cable-lug adapters oriented to the front

Details

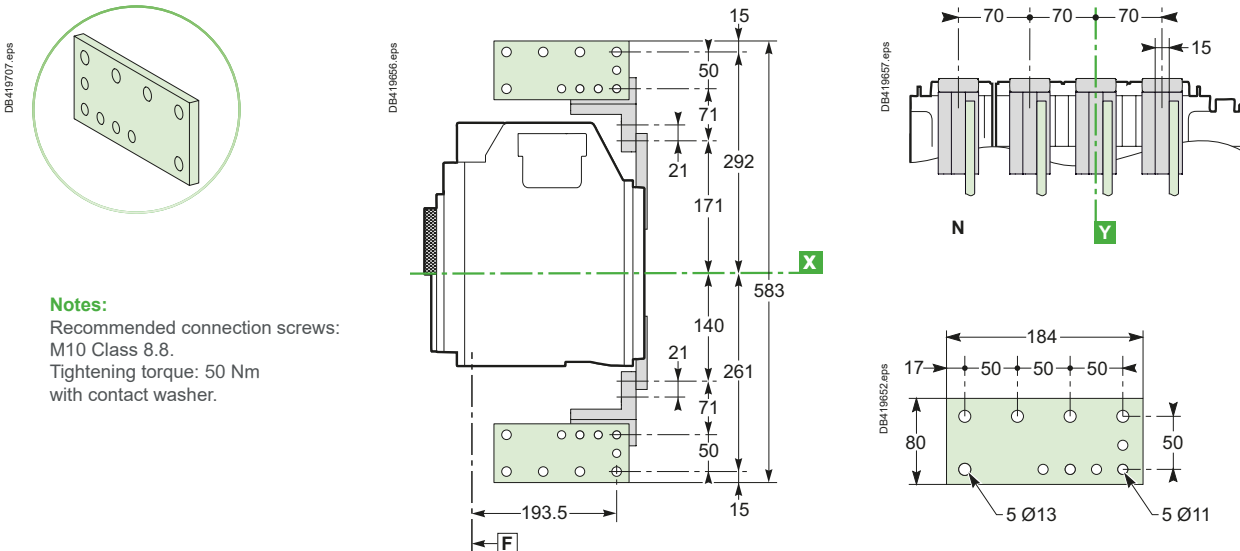

Notes:
 Recommended connection screws:
 M10 Class 8.8.
 Tightening torque: 50 Nm
 with contact washer.

Spacers (kit 04691)

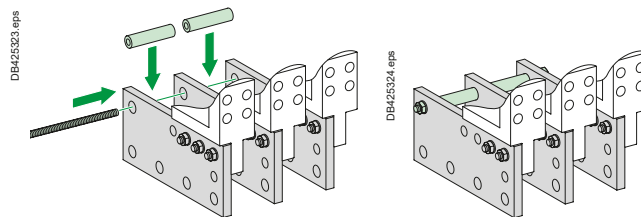

Spacers must be mounted between the cable lug adapters to withstand the electrodynamic stresses in the event of a short-circuit.

Vertical connection adapters fitted with cable-lug adapters oriented to the rear

Details

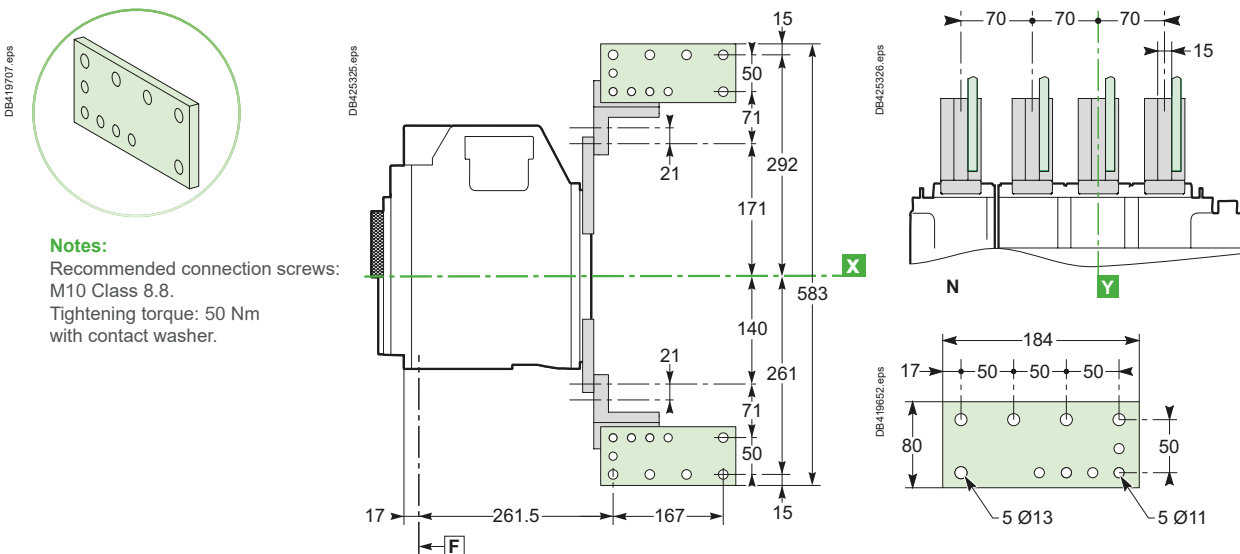

Notes:
 Recommended connection screws:
 M10 Class 8.8.
 Tightening torque: 50 Nm
 with contact washer.

Spacers (kit 04691)

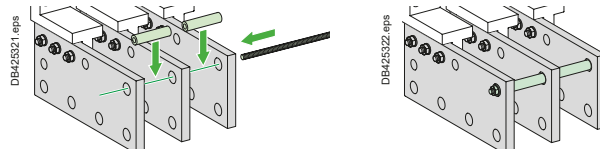

Spacers must be mounted between the cable lug adapters to withstand the electrodynamic stresses in the event of a short-circuit.



Dimensions

MasterPacT MTZ2 08 to MTZ2 32 fixed 3/4-pole devices

Dimensions

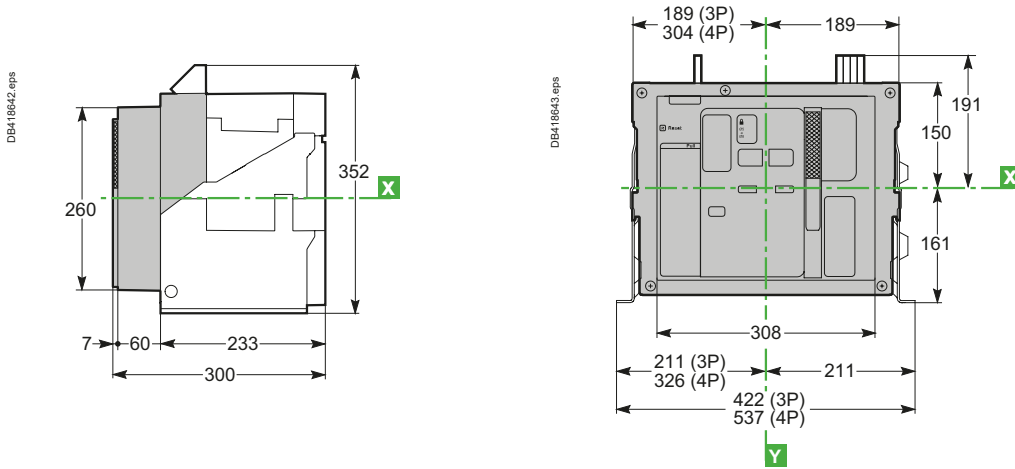

Mounting on base plate or rails

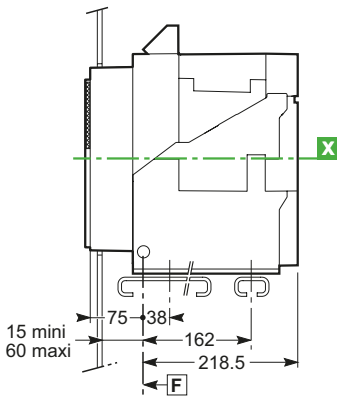

Mounting detail

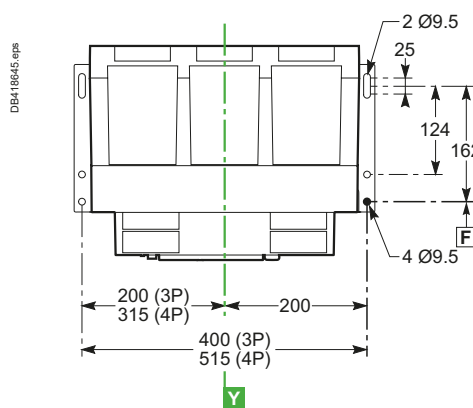

Door cutout

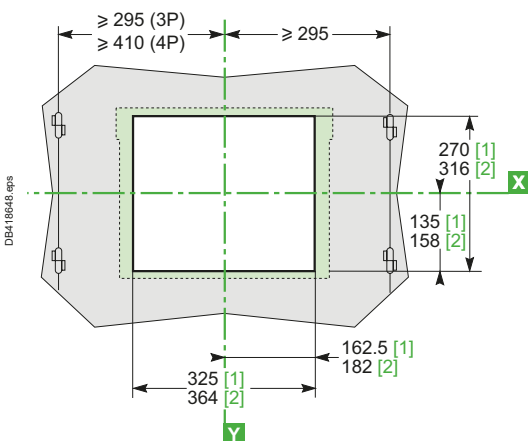

Clearance distances

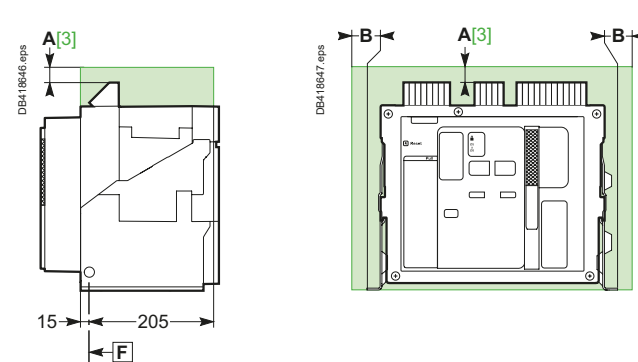

- [1] Without escutcheon.
- [2] With escutcheon.
- [3] An overhead clearance of 110 mm is required to remove the arc chutes.
- An overhead clearance of 20 mm is required to remove the terminal block.
- Note:** [F] Datum, circuit breaker or chassis mounting hole.
- [X] and [Y] are the symmetry planes for a 3-pole device.

MTZ2 devices except MTZ2-HA10

	Insulated parts	Metal parts	Energized parts
A	0	0	100
B	0	0	60

MTZ2-HA10

A	20	80	320
B	0	10	100

Dimensions

MasterPacT MTZ2 08 to MTZ2 32 fixed 3/4-pole devices

Connections

Horizontal rear connection

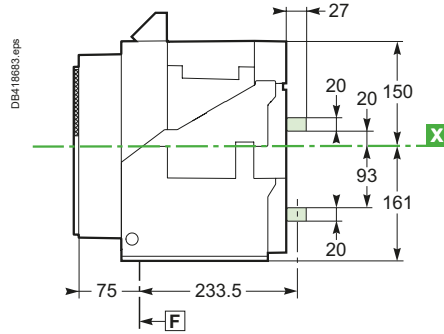
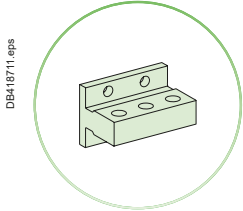

Details

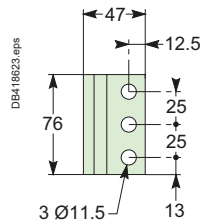
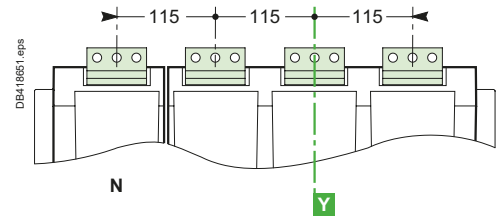

Vertical rear connection

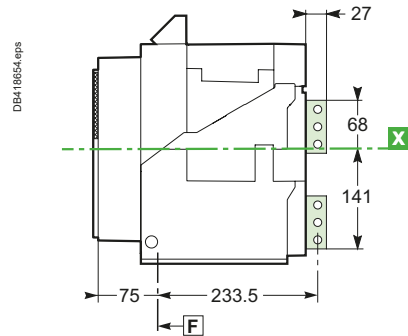
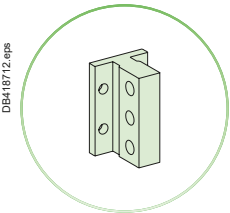

Details

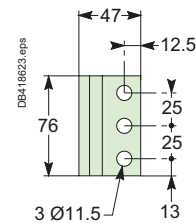
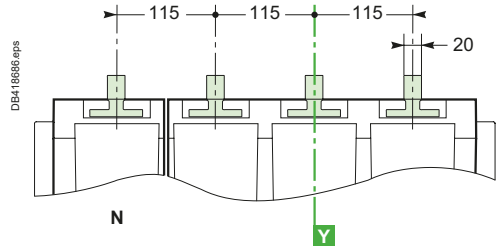

Front connection

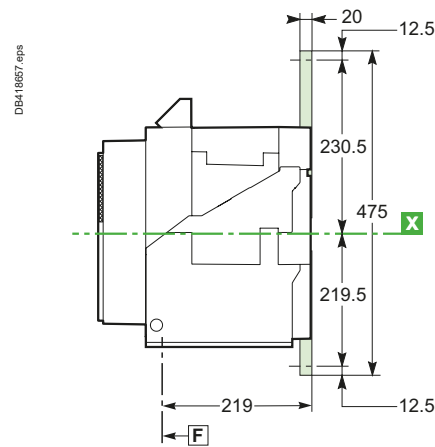
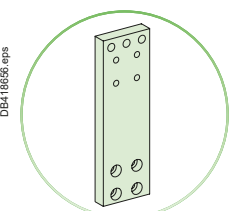

Details

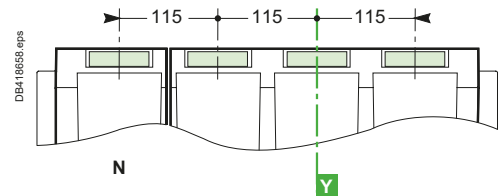

Top connection

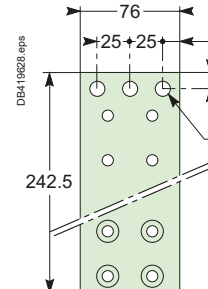

Bottom connection

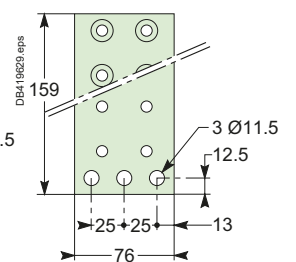

Note: Recommended connection screws: M10 Class 8.8. Tightening torque: 50 Nm with contact washer.



Dimensions

MasterPacT MTZ2 08 to MTZ2 32 drawout 3/4-pole devices

Dimensions

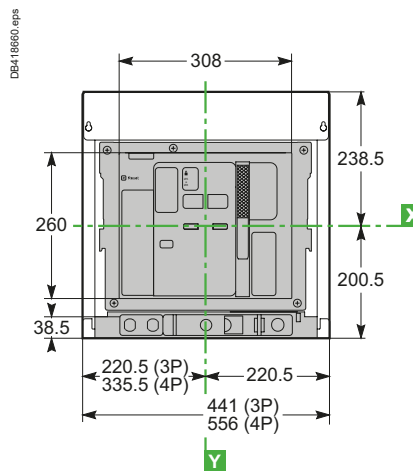
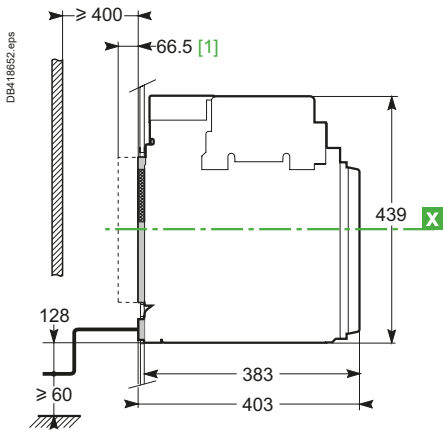

Clearance distances

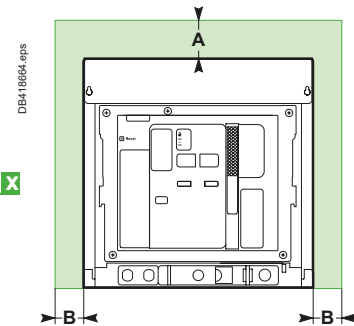

	Insulated parts	Metal parts	Energized parts
A	0	0	0
B	0	0	60

The clearance distances take into account the space required to remove the arc chutes.

Mounting on base plate or rails

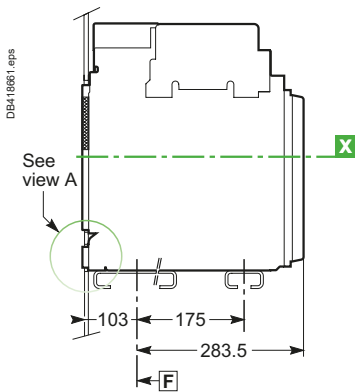

Mounting detail

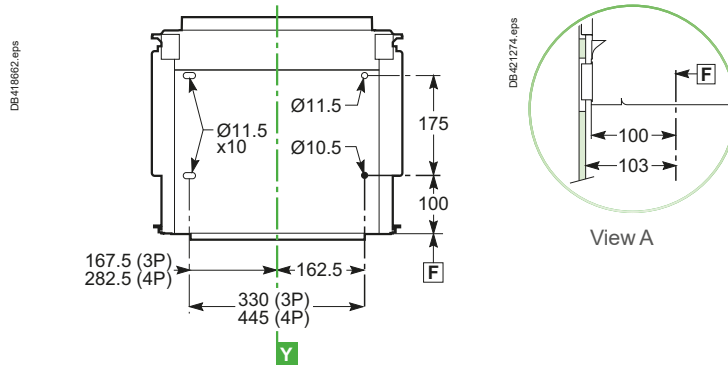

Door cutout without escutcheon

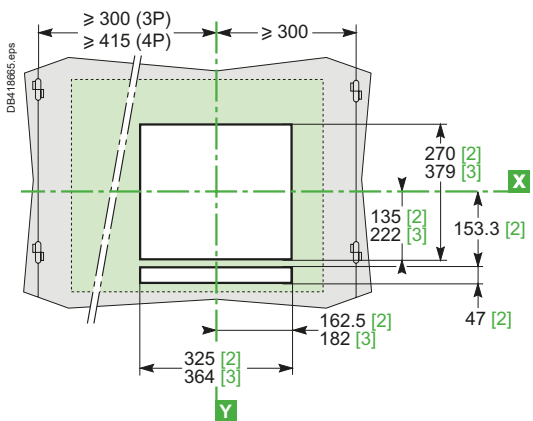

Door cutout with escutcheon

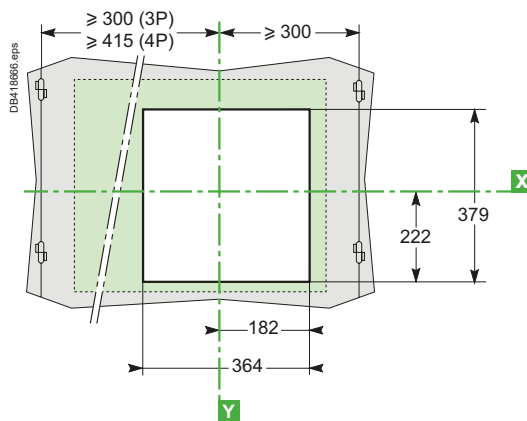

[1] Disconnected position.

Note: F Datum, circuit breaker or chassis mounting hole.
X and Y are the symmetry planes for a 3-pole device.

Dimensions

MasterPacT MTZ2 08 to MTZ2 32 drawout 3/4-pole devices

Connections

Horizontal rear connection

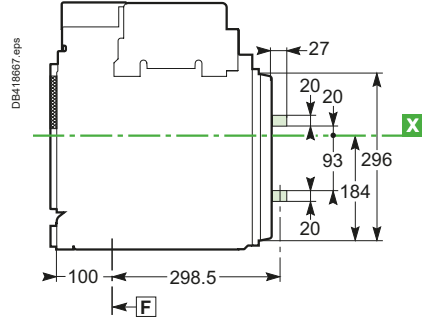
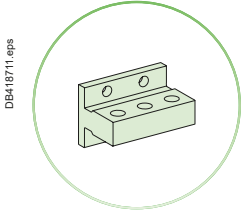

Details

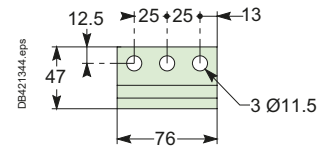
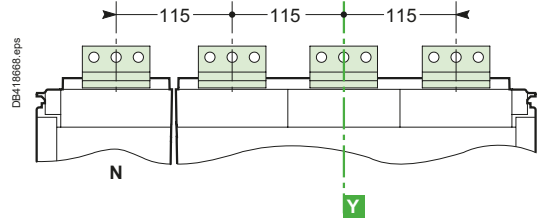

Vertical rear connection

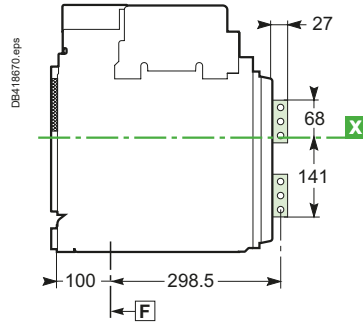
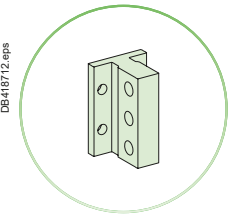

Details

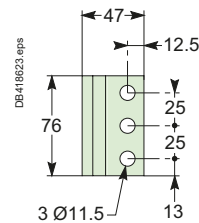
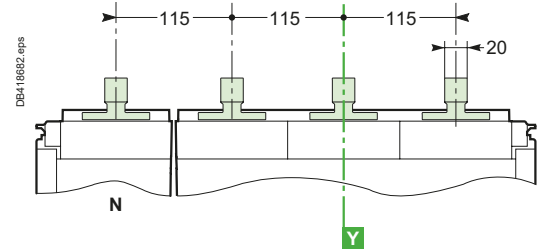

Front connection

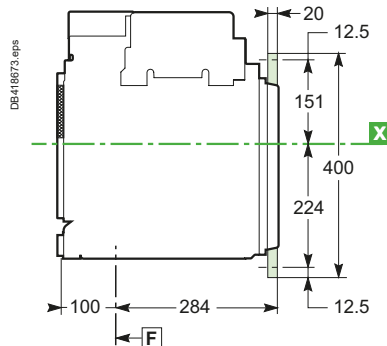
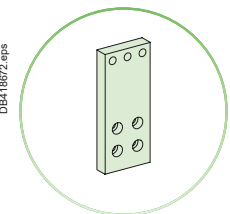

Details

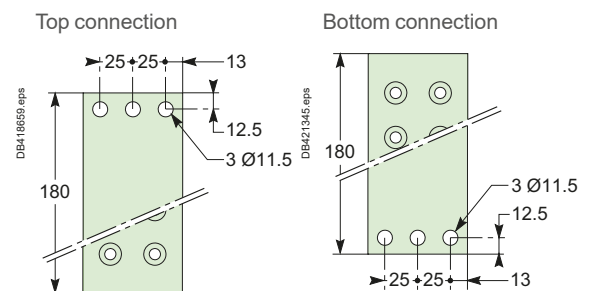
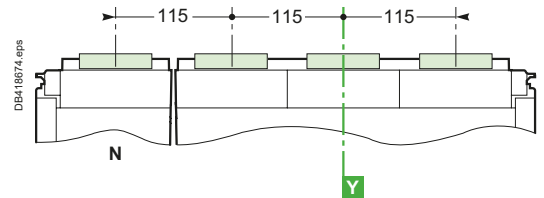

Note: Recommended connection screws: M10 Class 8.8.
Tightening torque: 50 Nm with contact washer.



Dimensions

MasterPacT MTZ2 40 fixed 3/4-pole devices

Dimensions

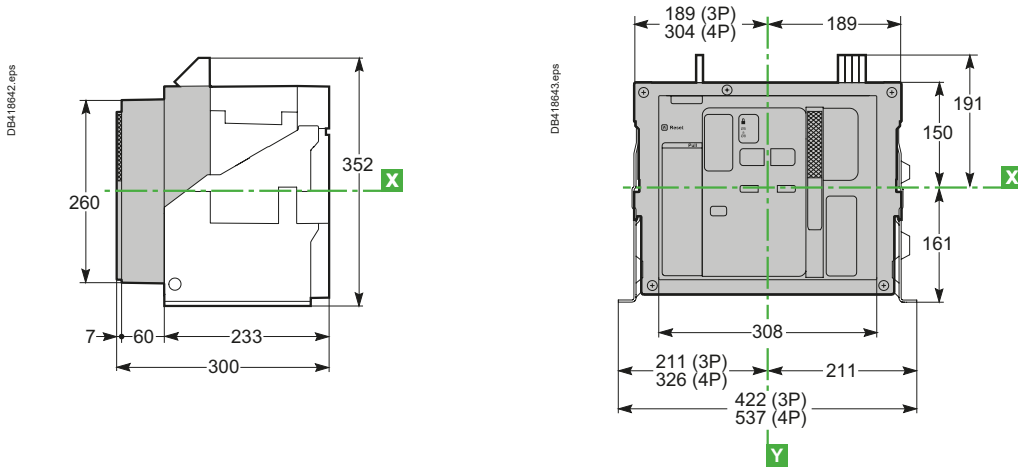

Mounting on base plate or rails

Mounting detail

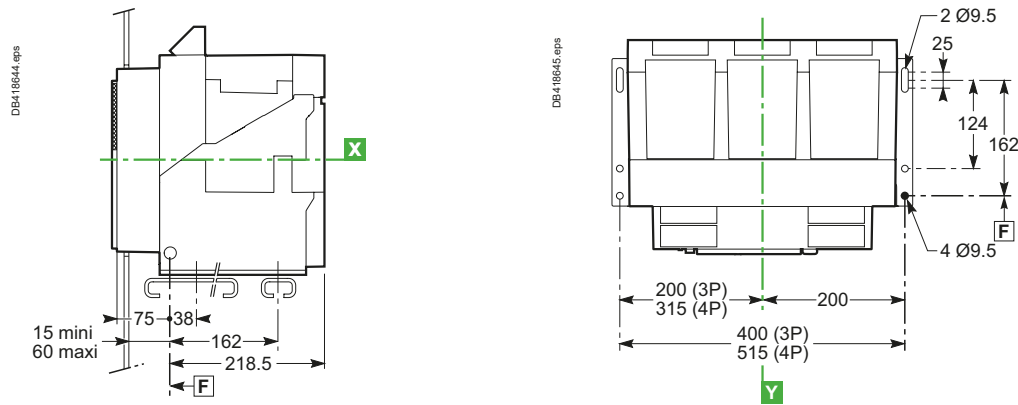

Door cutout

Clearance distances

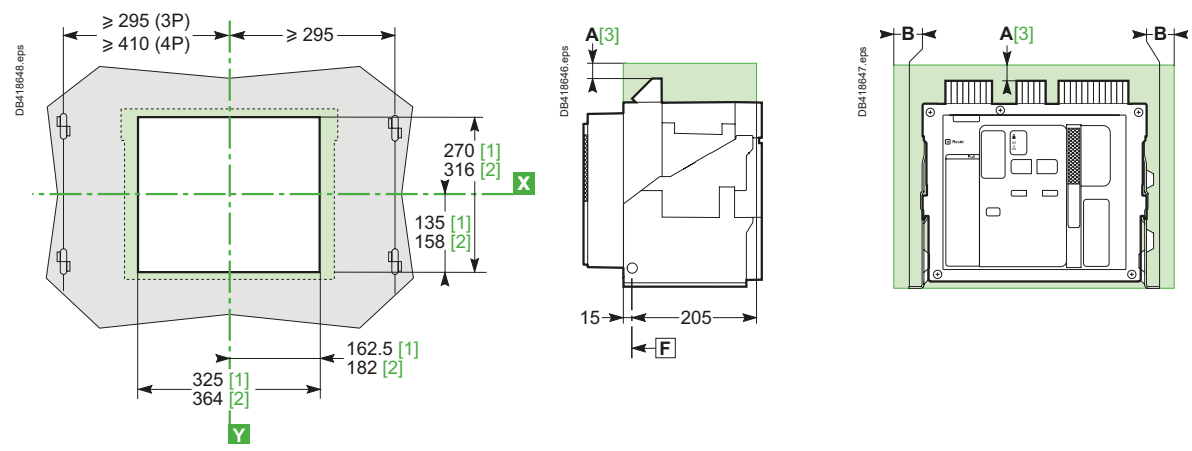

- [1] Without escutcheon.
 - [2] With escutcheon.
 - [3] An overhead clearance of 110 mm is required to remove the arc chutes.
An overhead clearance of 20 mm is required to remove the terminal block.
- Note:** [F] Datum, circuit breaker or chassis mounting hole.
[X] and [Y] are the symmetry planes for a 3-pole device.

MTZ2 devices except MTZ2-HA10

	Insulated parts	Metal parts	Energized parts
A	0	0	100
B	0	0	60

MTZ2-HA10

	Insulated parts	Metal parts	Energized parts
A	20	80	320
B	0	10	100

Dimensions

MasterPacT MTZ2 40 fixed 3/4-pole devices

Connections

Horizontal rear connection

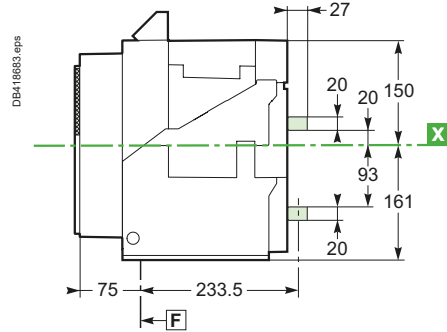
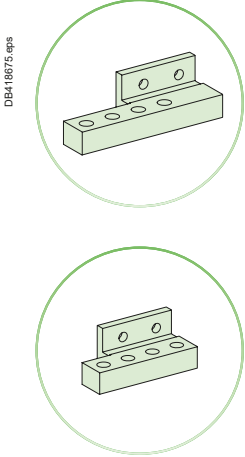

Details

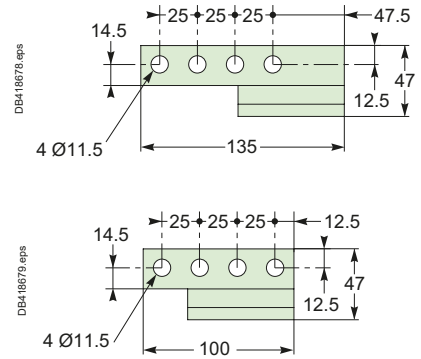
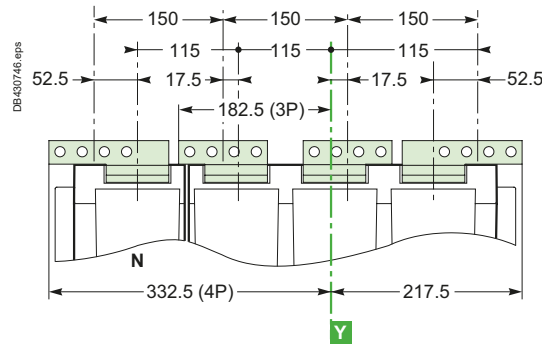

Vertical rear connection

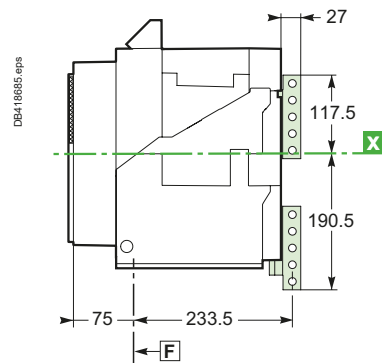
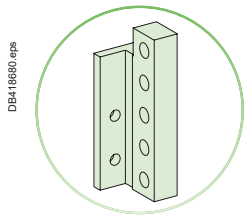

Details

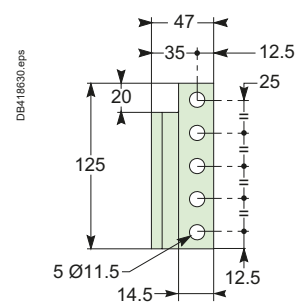
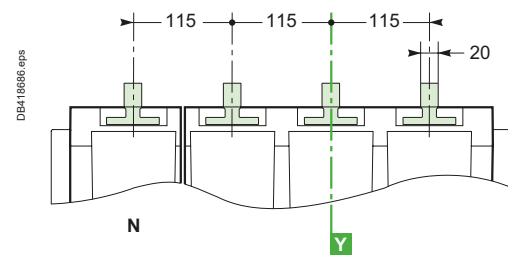

Note: Recommended connection screws: M10 stainless steel A4-80.
Tightening torque: 50 Nm with contact washer.
For 4000 A and above standard steel screws can generate additional temperature rise at connection point.



Dimensions

MasterPacT MTZ2 40 drawout 3/4-pole devices

Dimensions

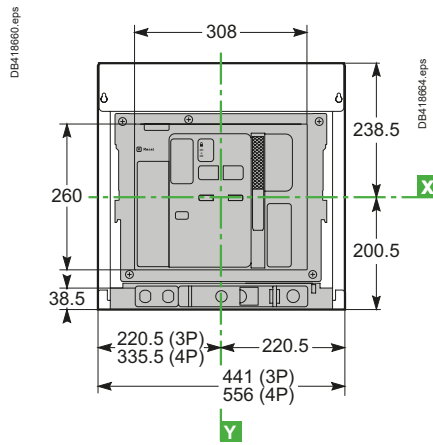
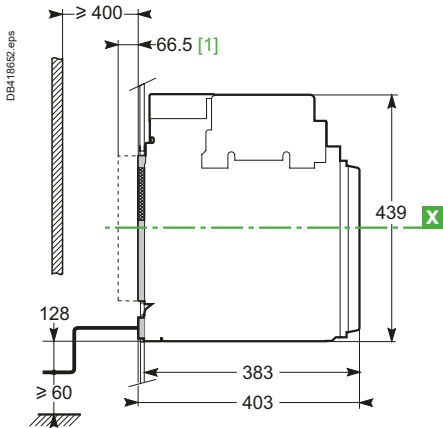

Clearance distances

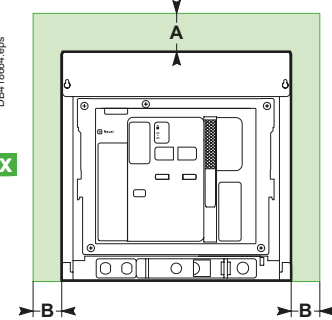

	Insulated parts	Metal parts	Energized parts
A	0	0	0
B	0	0	60

The clearance distances take into account the space required to remove the arc chutes.

Mounting on base plate or rails

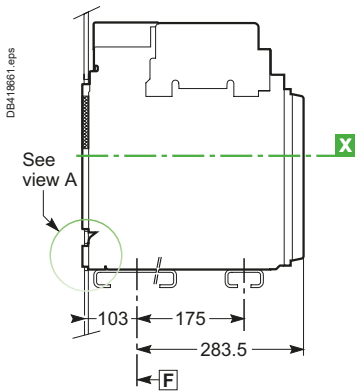

Mounting detail

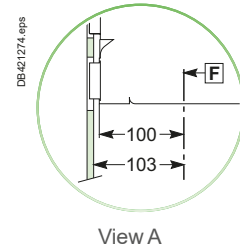
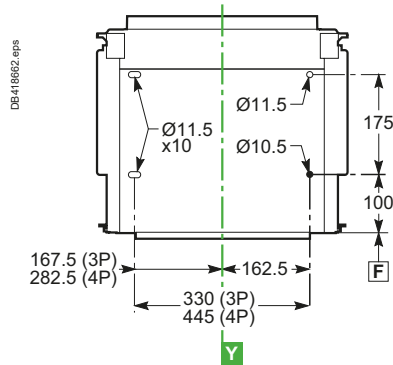

Door cutout without escutcheon

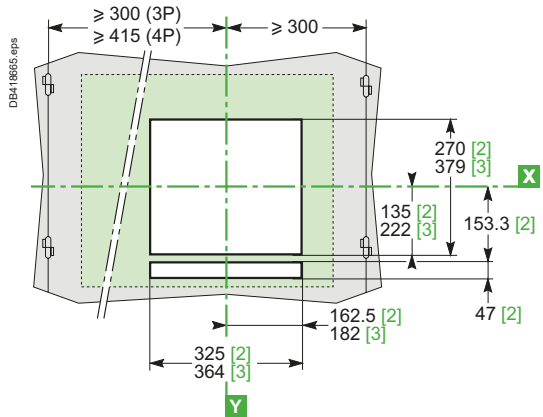

Door cutout with escutcheon

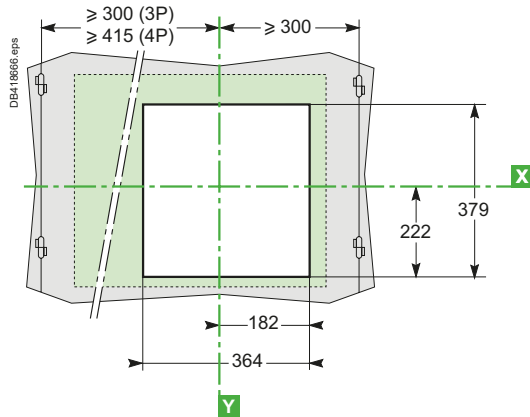

[1] Disconnected position.

Note: F Datum, circuit breaker or chassis mounting hole.

X and Y are the symmetry planes for a 3-pole device.

Dimensions

MasterPacT MTZ2 40 drawout 3/4-pole devices

Connections

Horizontal rear connection

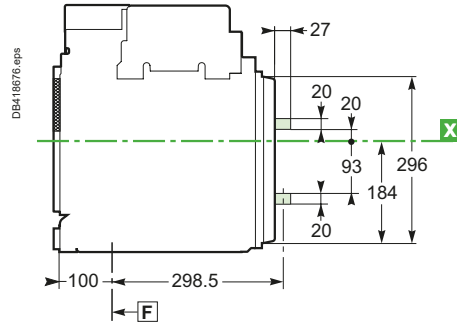
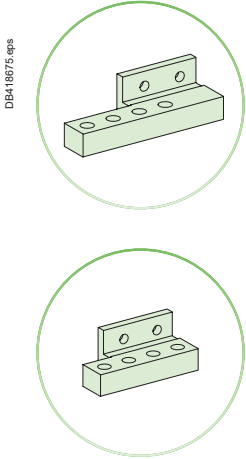

Details

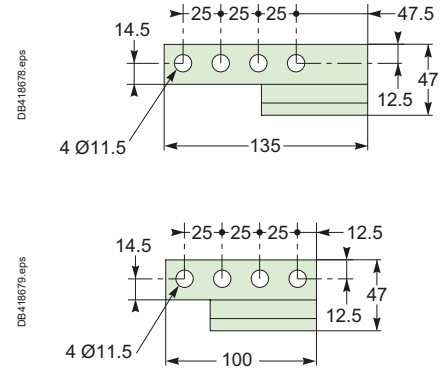
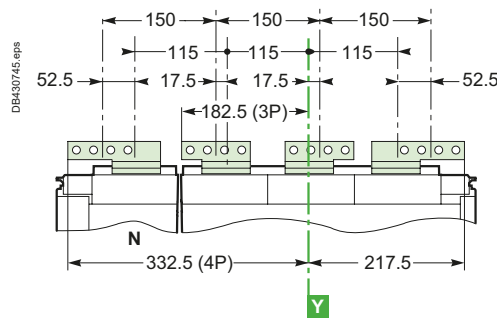

Vertical rear connection

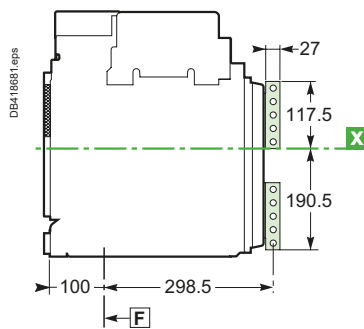
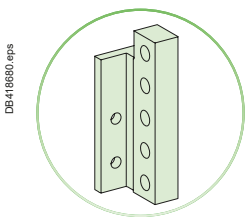

Details

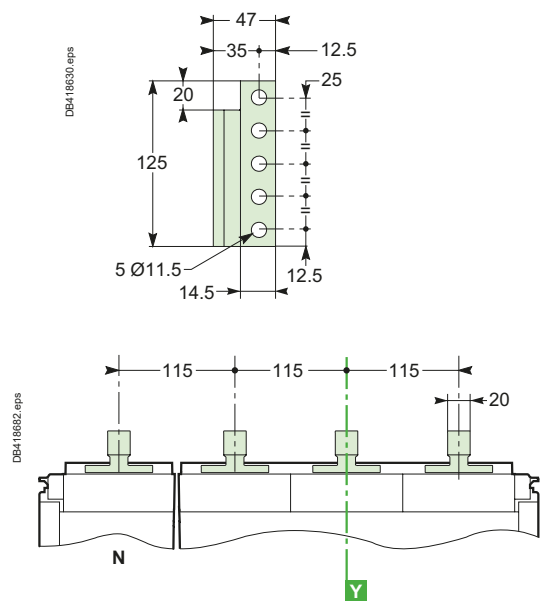

Note: Recommended connection screws: M10 stainless steel A4-80.
Tightening torque: 50 Nm with contact washer.
For 4000 A and above standard steel screws can generate additional temperature rise at connection point.



Dimensions

MasterPacT MTZ3 fixed 3/4-pole devices

Dimensions

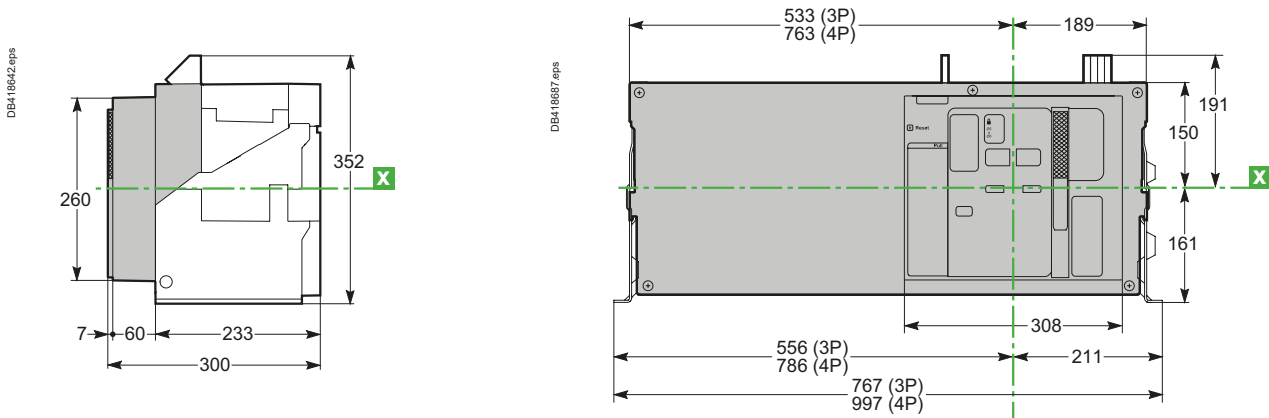

Mounting on base plate or rails

Mounting detail

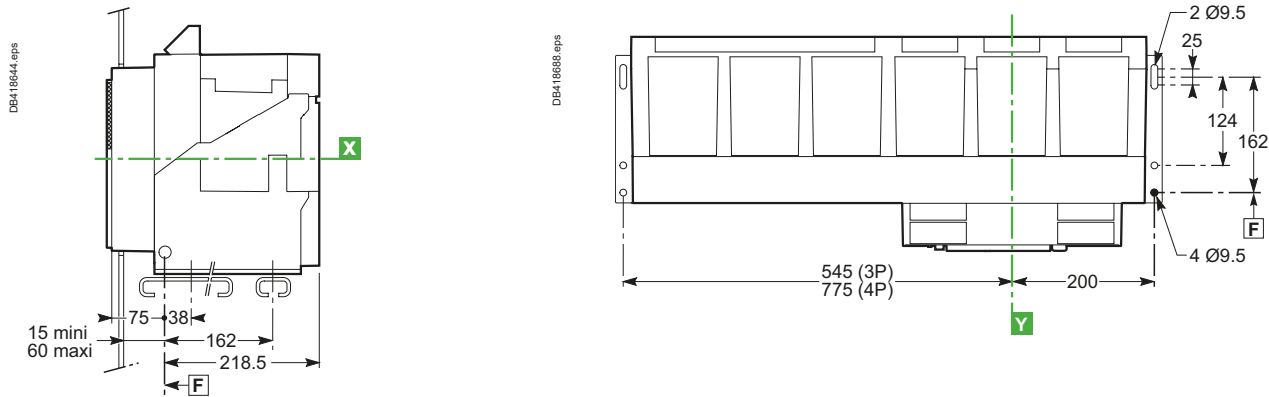

Door cutout

Clearance distances

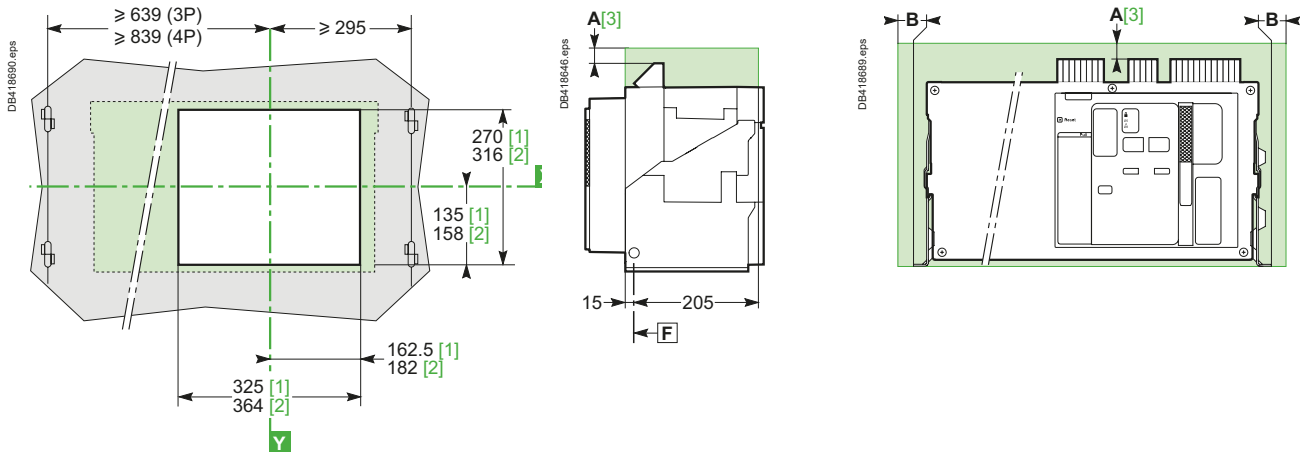

- [1] Without escutcheon.
 - [2] With escutcheon.
 - [3] An overhead clearance of 110 mm is required to remove the arc chutes.
An overhead clearance of 20 mm is required to remove the terminal block.
- Note:** F Datum, circuit breaker or chassis mounting hole.
X and Y are the symmetry planes for a 3-pole device.

	Insulated parts	Metal parts	Energized parts
A	0	0	100
B	0	0	60

Dimensions

MasterPacT MTZ3 fixed 3/4-pole devices

Connections

Horizontal rear connection (MTZ3 40 to 50)

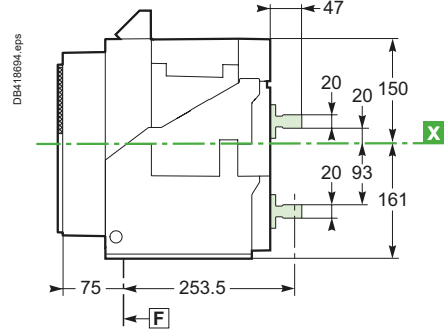
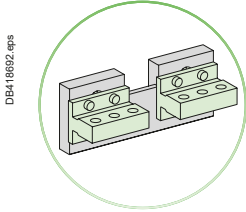

Details

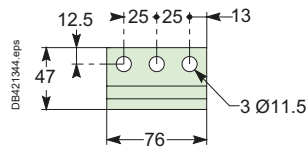
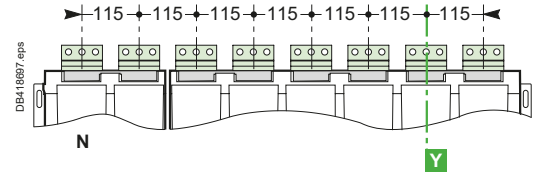

Vertical rear connection (MTZ3 40 to 50)

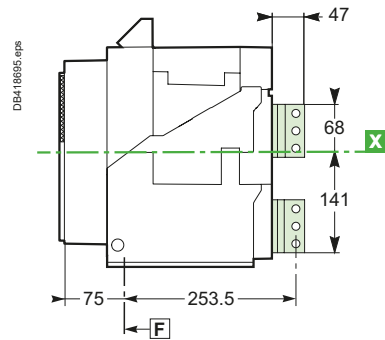
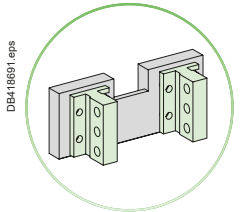

Details

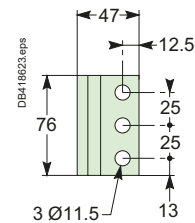
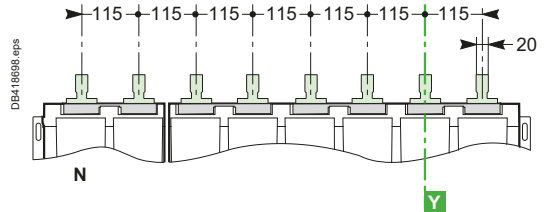

Vertical rear connection (MTZ3 63)

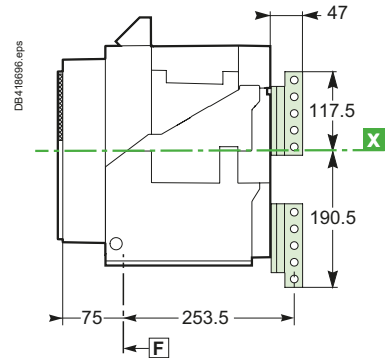
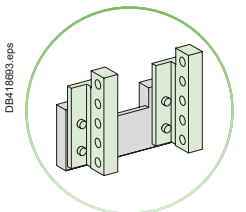

Details

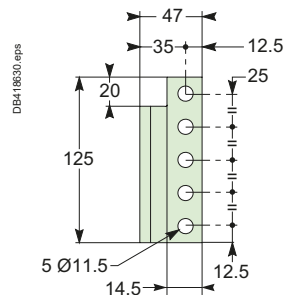
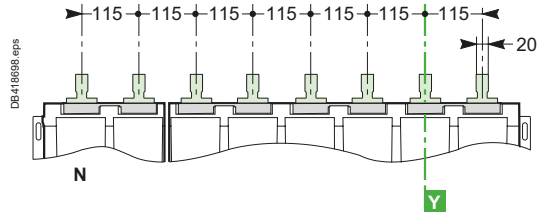

Note: Recommended connection screws: M10 stainless steel A4-80.
Tightening torque: 50 Nm with contact washer.
For 4000 A and above standard steel screws can generate additional temperature rise at connection point.



Dimensions

MasterPacT MTZ3 drawout 3/4-pole devices

Dimensions

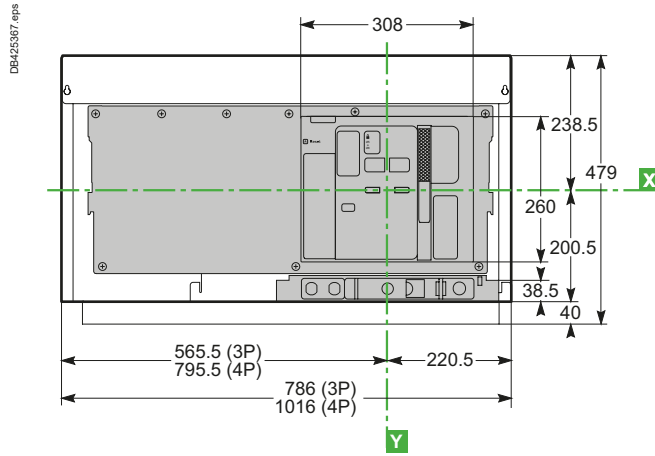
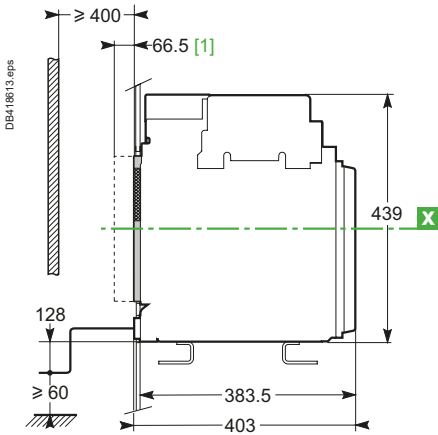

Mounting on base plate or rails

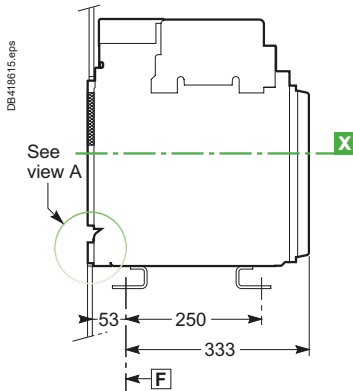

Mounting detail

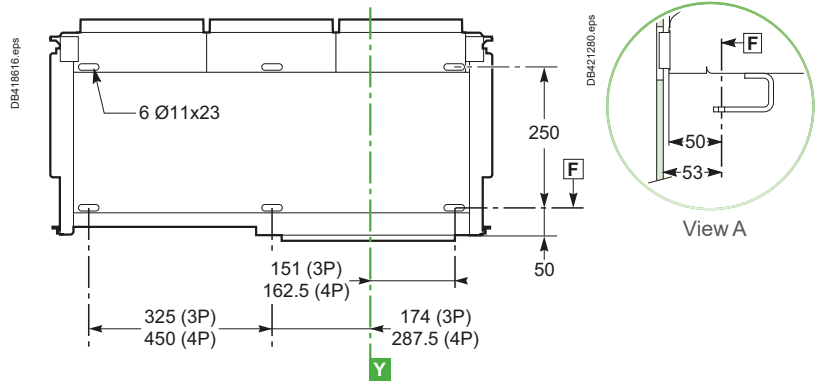

Clearance distances

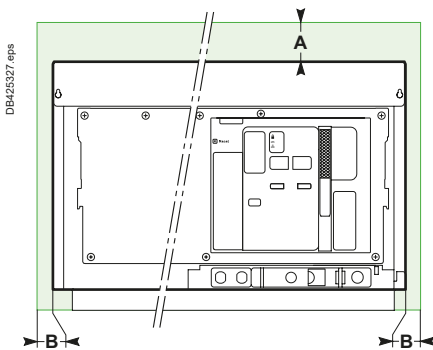

Door cutout without escutcheon

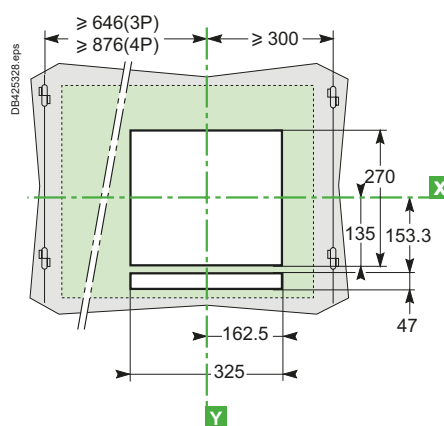

Door cutout with escutcheon

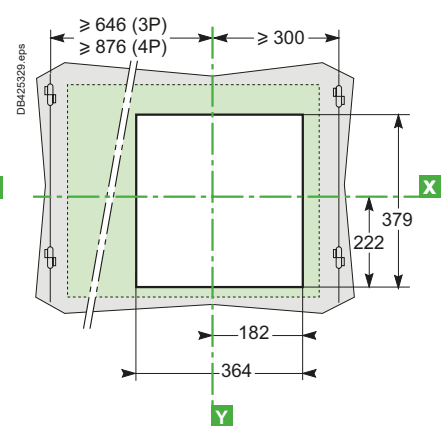

	Insulated parts	Metal parts	Energized parts
A	0	0	0
B	0	0	60

[1] Disconnected position.

The clearance distances take into account the space required to remove the arc chutes.

Note: F Datum, circuit breaker or chassis mounting hole.

X and Y are the symmetry planes for a 3-pole device.

Dimensions

MasterPacT MTZ3 drawout 3/4-pole devices

Connections

Horizontal rear connection (MTZ3 40 to 50)

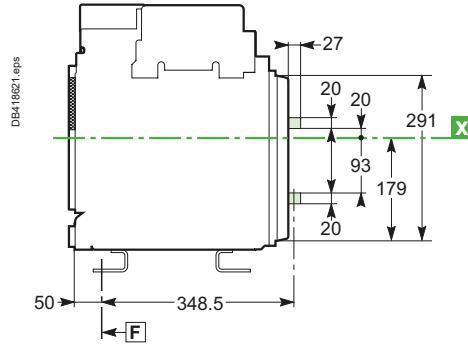
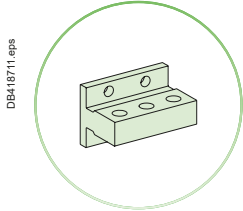

Details

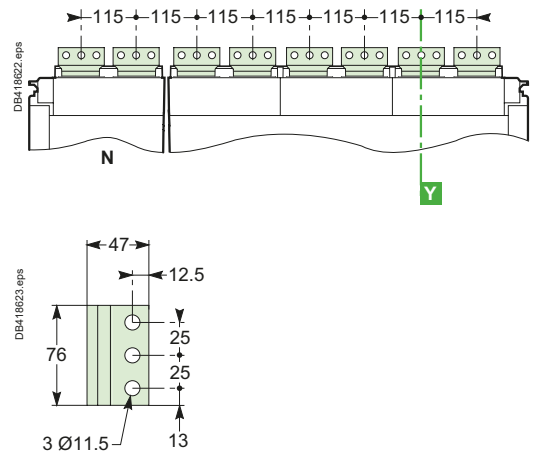

Vertical rear connection (MTZ3 40 to 50)

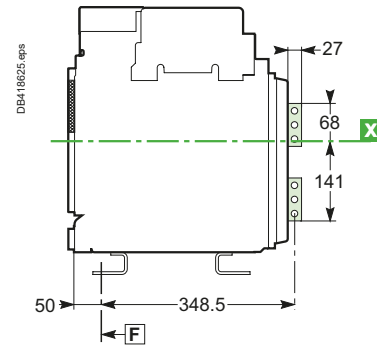
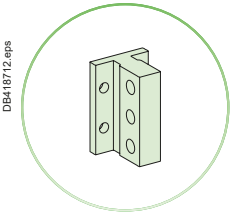

Details

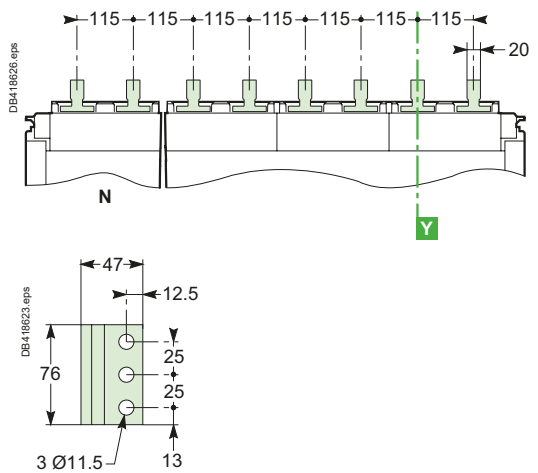

Vertical rear connection (MTZ3 63)

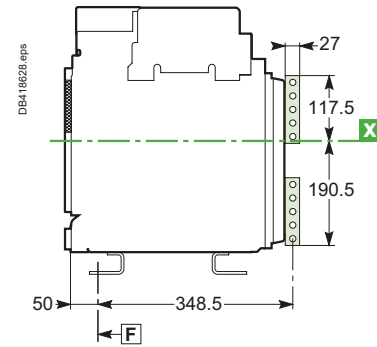
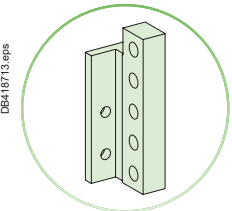

Details

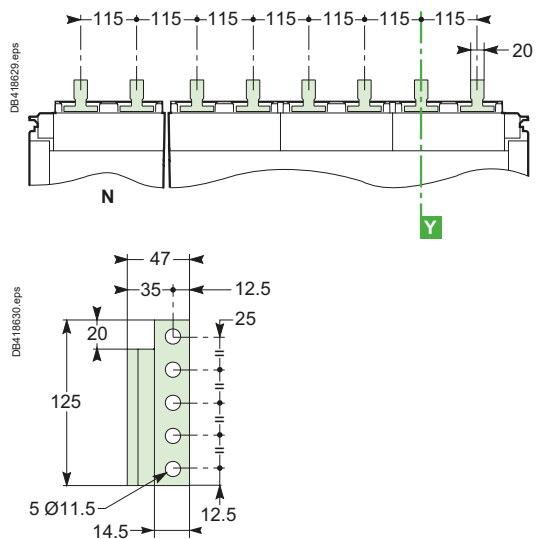

Note: Recommended connection screws: M10 stainless steel A4-80.
Tightening torque: 50 Nm with contact washer.
For 4000 A and above standard steel screws can generate additional temperature rise at connection point.



Dimensions Accessories

Mounting on backplate with special brackets (MasterPacT MTZ2 08 to 32 fixed)

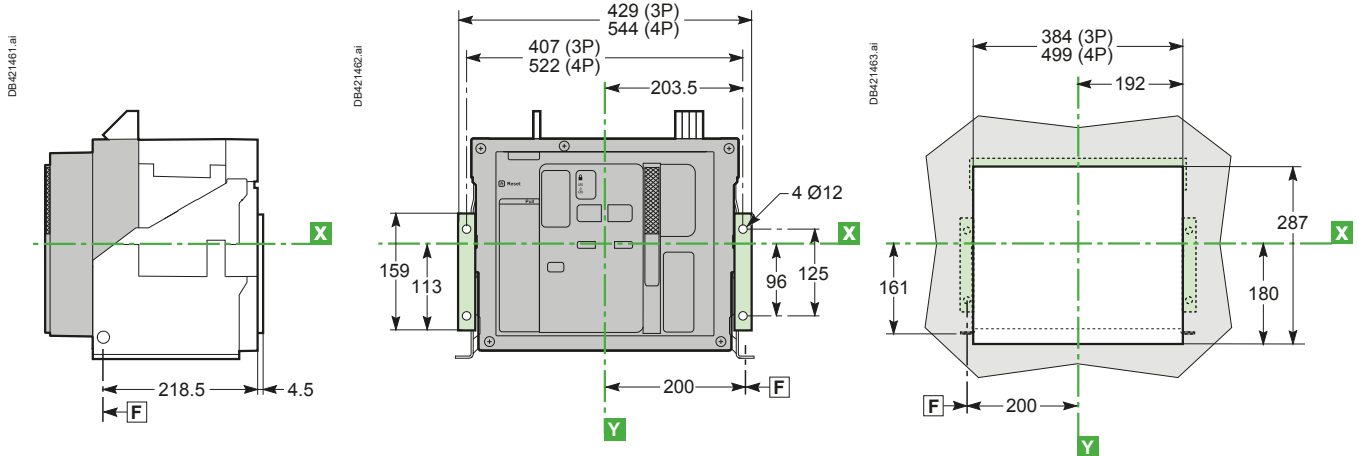

Front-connection adapter (MasterPacT MTZ2 08 to 32 fixed)

Horizontal rear connection

Detail

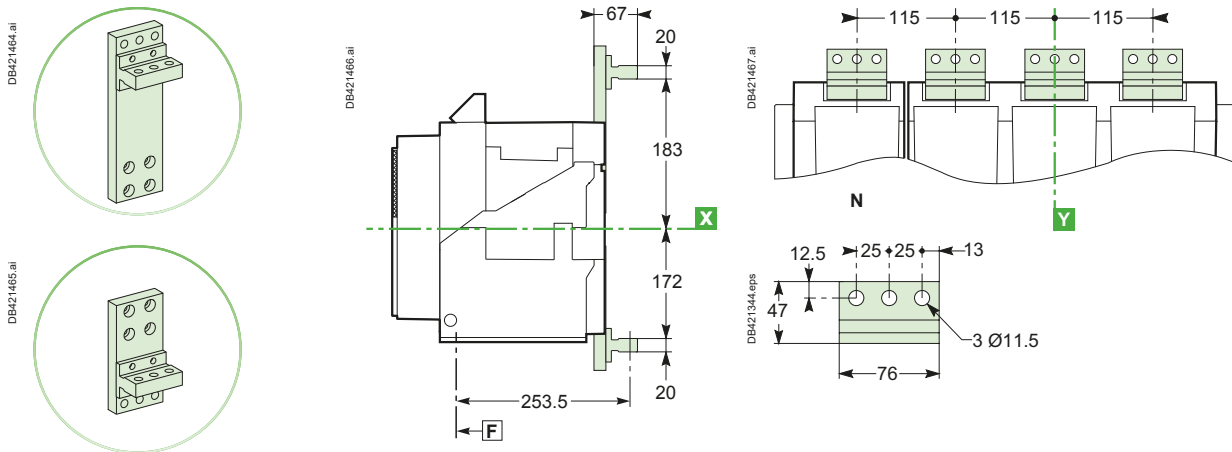

Disconnectable front-connection adapter (MasterPacT MTZ2 08 to 32 fixed)

Vertical rear connection

Detail

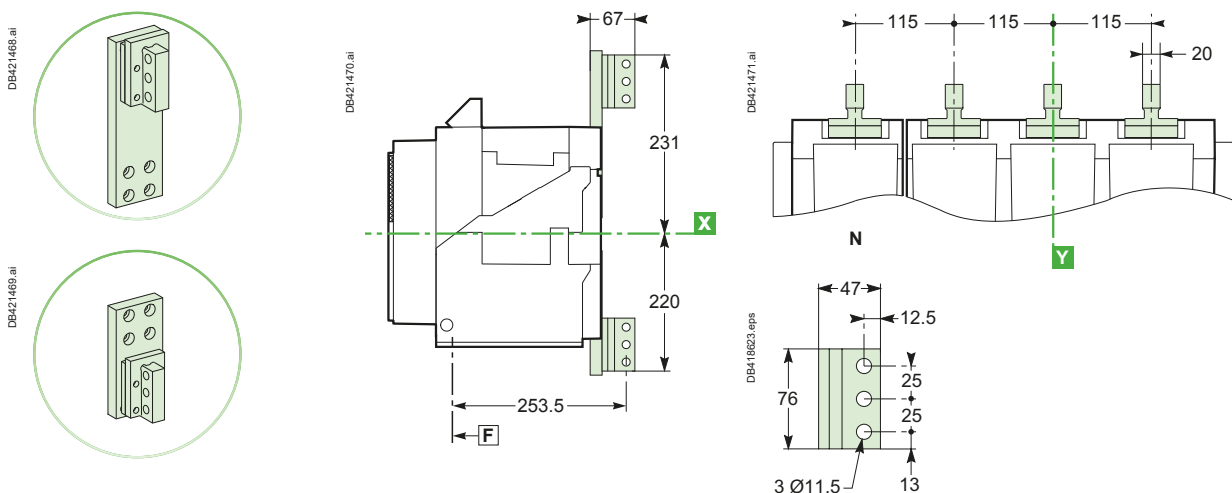

Note: Recommended connection screws: M10 Class 8.8.
Tightening torque: 50 Nm with contact washer.

F Datum, circuit breaker or chassis mounting hole.
X and **Y** are the symmetry planes for a 3-pole device.

Rear panel cutout (drawout devices)

MTZ1

Rear view

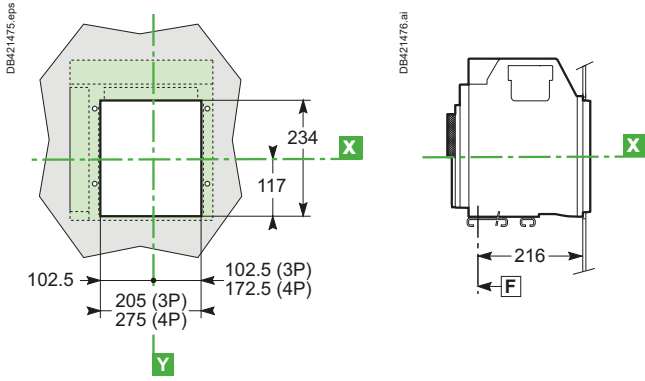

MTZ2 08 to MTZ2 40

Rear view

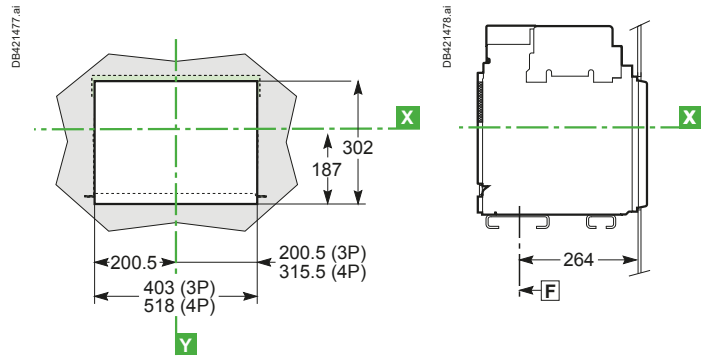

MTZ3 40 to MTZ3 63

Rear view

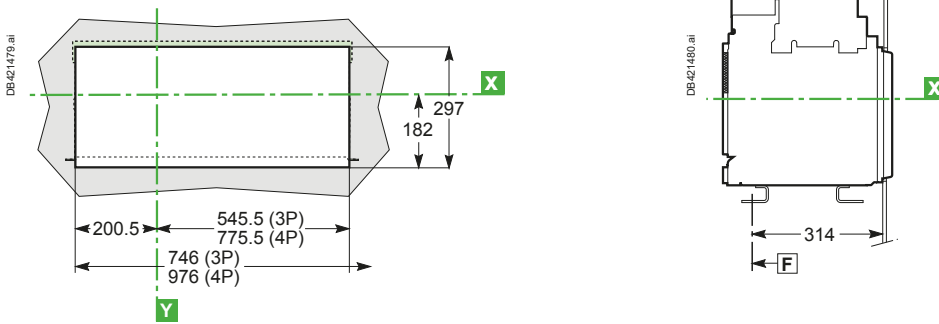

Escutcheon

MasterPacT MTZ1

Fixed device

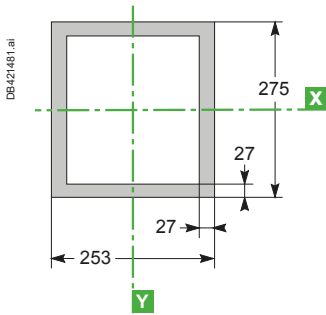

Drawout device

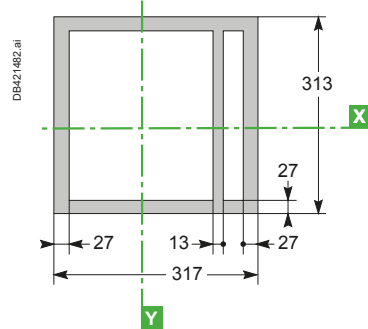

MasterPacT MTZ2/MTZ3

Fixed device

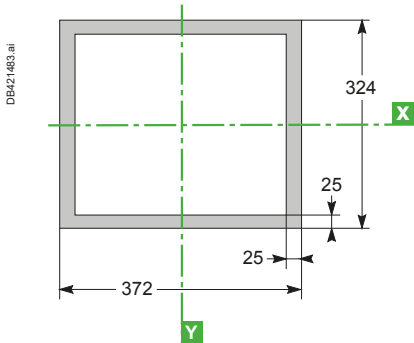

Drawout device

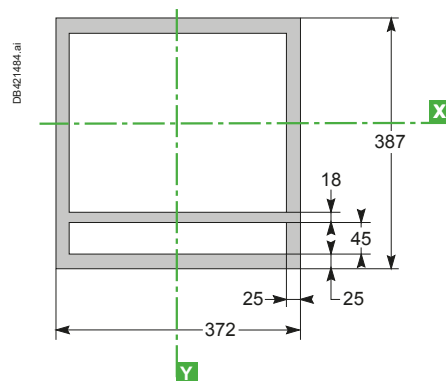

F Datum, circuit breaker or chassis mounting hole.
X and **Y** are the symmetry planes for a 3-pole device.



Dimensions

External modules

Connection of auxiliary wiring to terminal block

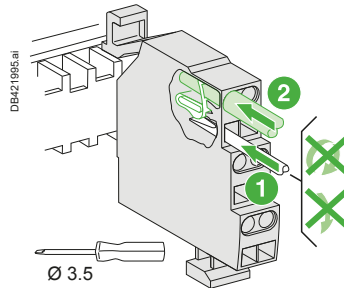
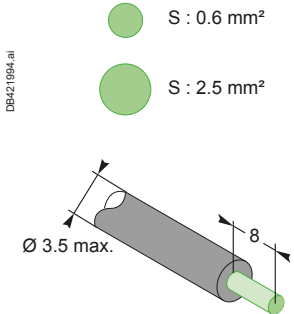

External MicroLogic power supply

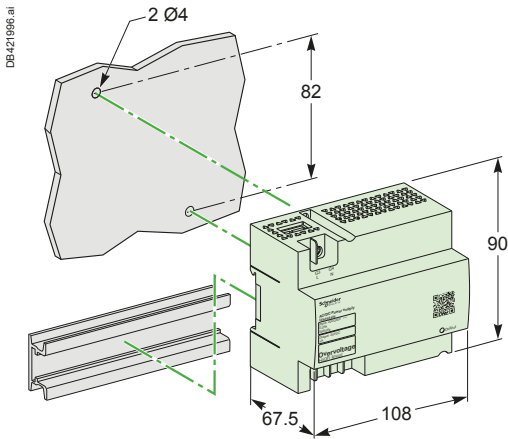

Battery module (BAT)

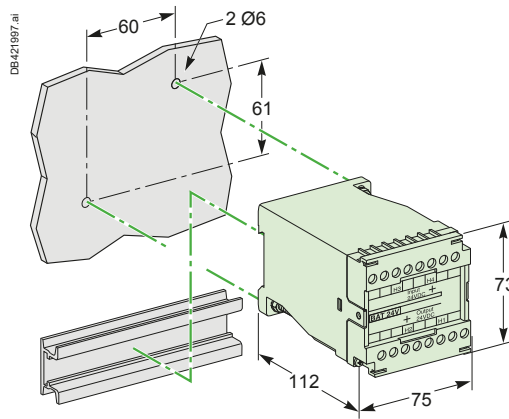

RIM

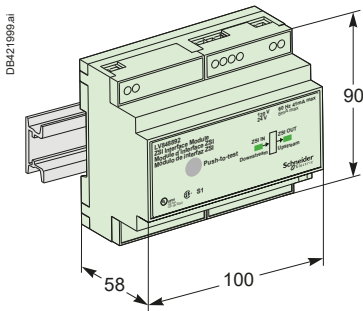

Delay unit for MN voltage release

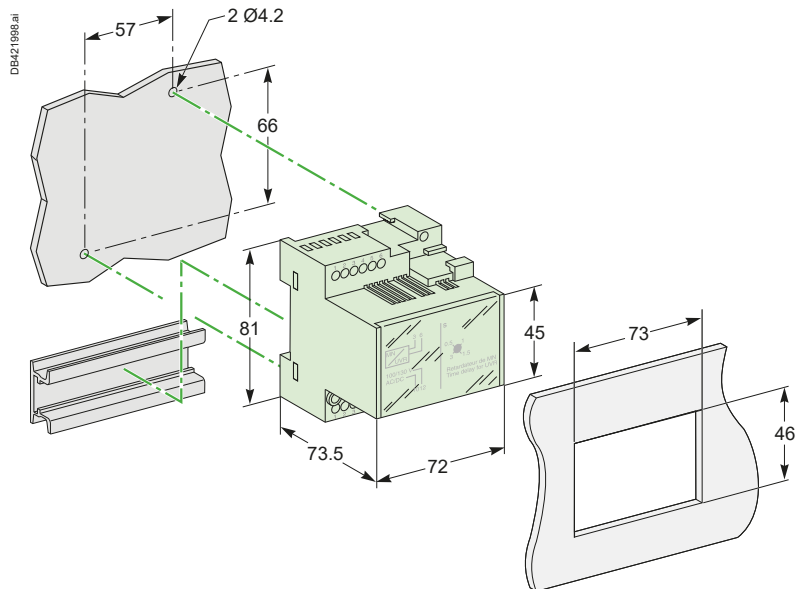

IFE - Ethernet interface

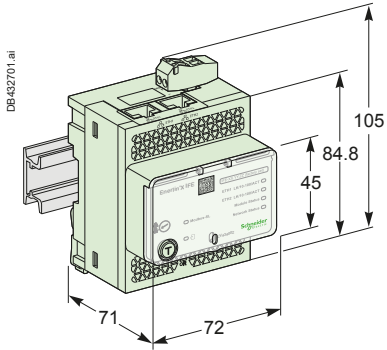

IFM - Modbus Interface

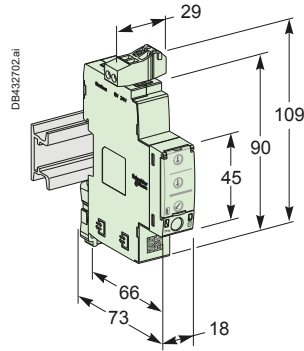

PAS600

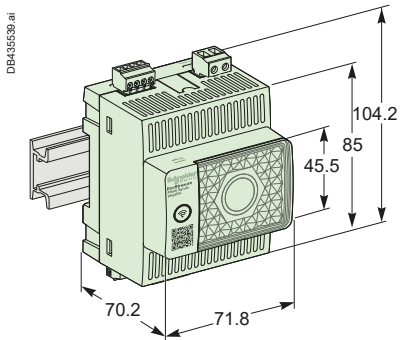

Dimensions

External modules

FDM121

Door cutout mounting

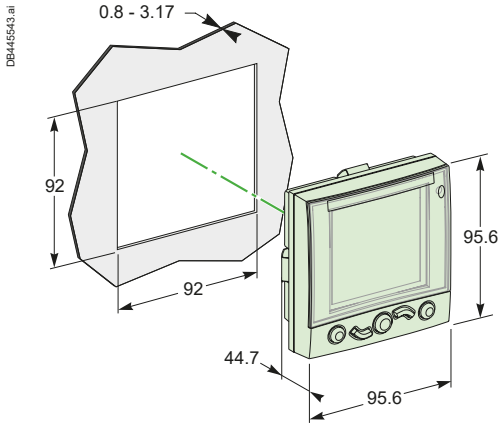

Hole mounting

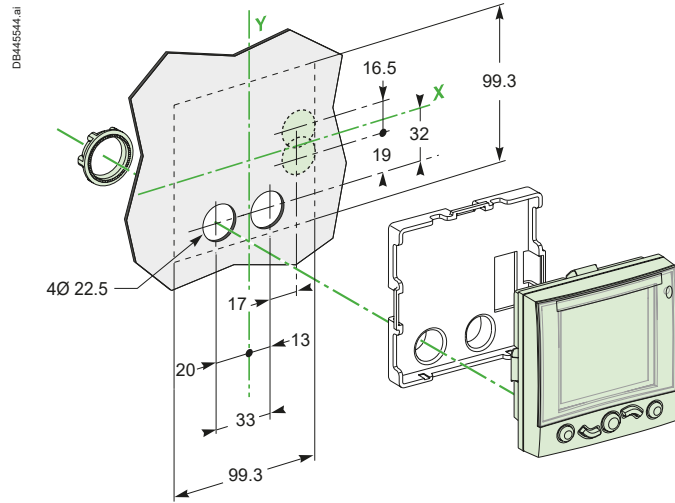

FDM128

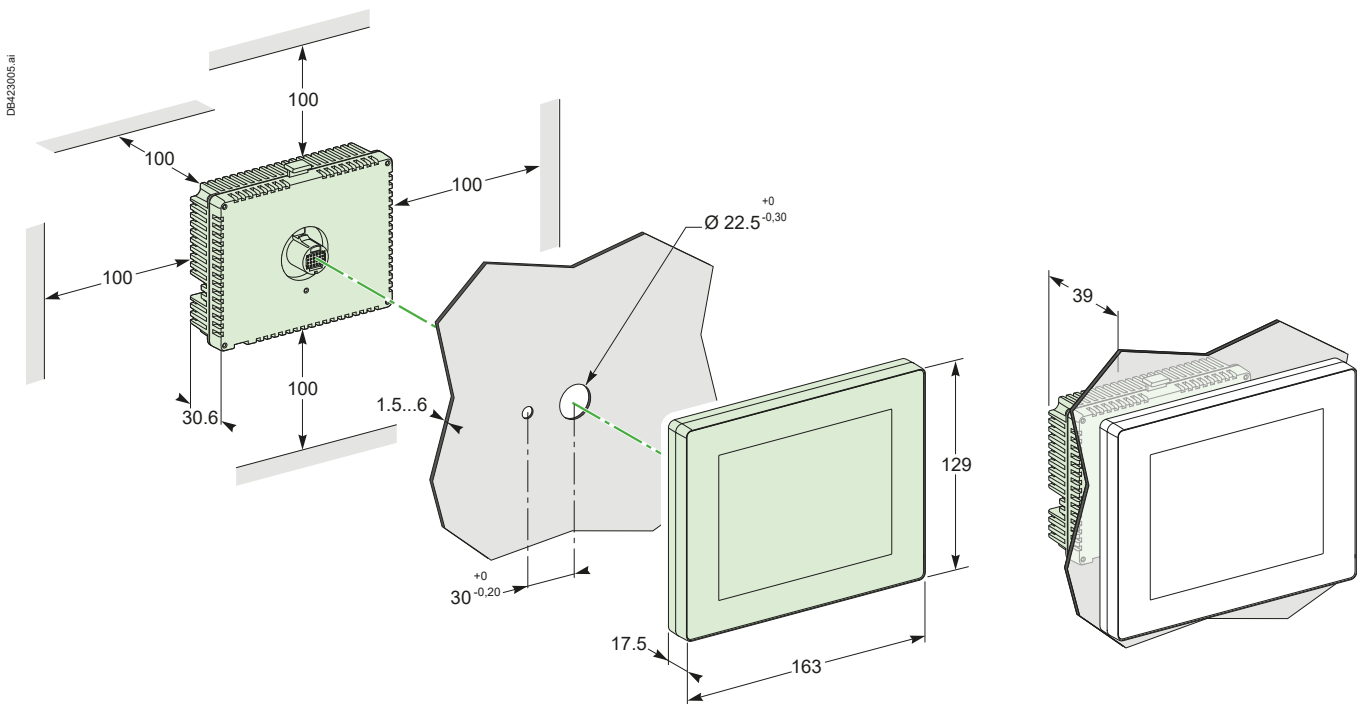

E

External sensor for external neutral

400/1600 A
(MTZ1 06 to MTZ1 16)

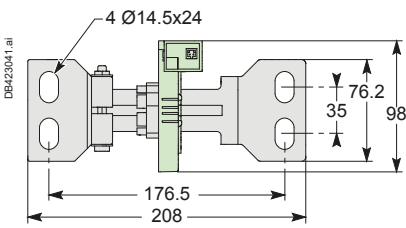
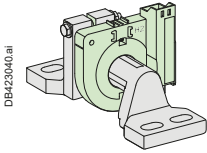

400/2000 A
(MTZ2 08 to MTZ2 20)

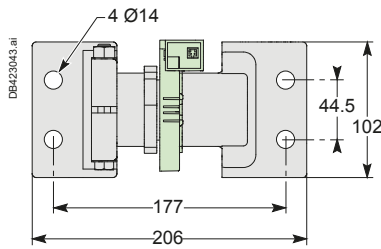
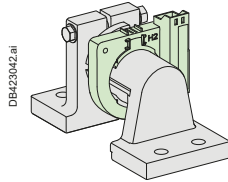

1000/4000 A
(MTZ2 25 to MTZ2 40)

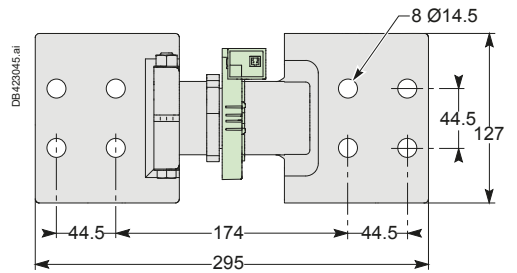
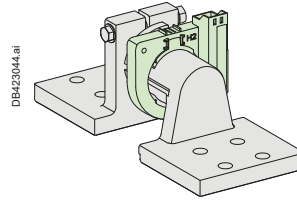

4000/6300 A
(MTZ3 40 to MTZ3 63)

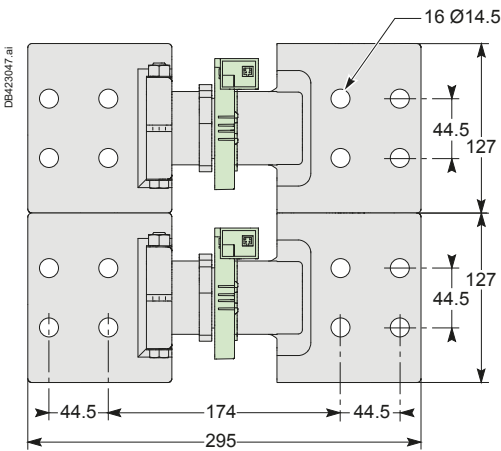
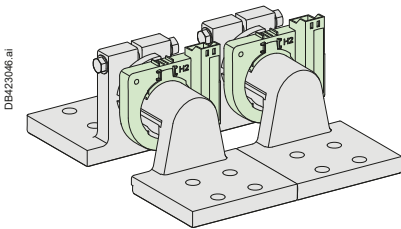

2000/6300 A
(MTZ2 to MTZ3)
single sensor kit

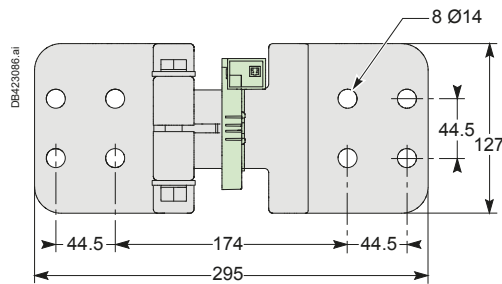
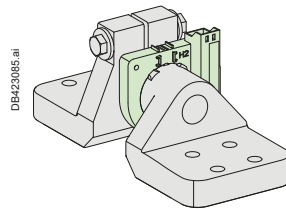

2000/6300 A
(MTZ2 to MTZ3)
3 layer bus

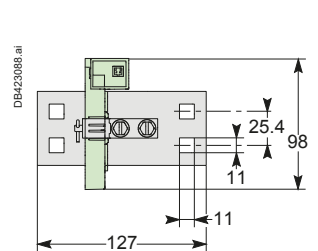
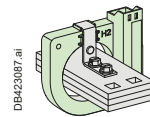

Dimensions

External modules

Busbars path

280 x 115 mm window
Busbars spaced 70 mm center-to-center

470 x 160 mm window
Busbars spaced 115 mm center-to-center

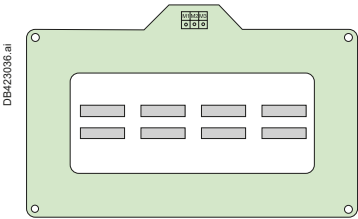

2 bars 50 x 10.

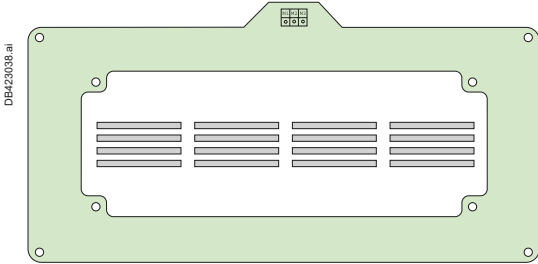

4 bars 100 x 5.

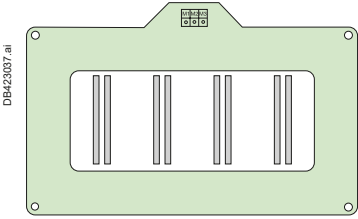

2 bars 100 x 5.

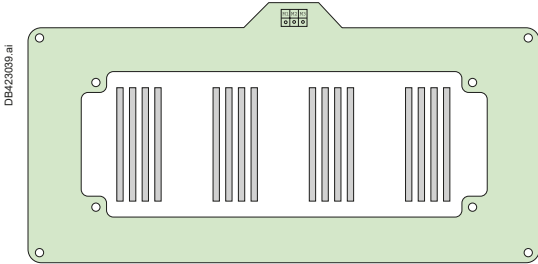

4 bars 125 x 5.



Clusters

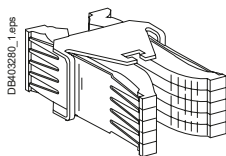

Table: number of clusters required for the different chassis models

Chassis rating (A)	MasterPacT MTZ1	
	3P	4P
630	12	16
800	12	16
1000	12	16
1250	12	16
1600	18	24

Note: the minimum order is 6 parts.

Table: number of clusters required for the different chassis models

Chassis rating (A)	MasterPacT MTZ2-3 3P						MasterPacT MTZ2-3 4P					
	N1, NA	H1, HA	HA10	H2, HH, HF	H3	L1	N1, NA	H1, HA	HA10	H2, HH, HF	H3	L1
MTZ2 08 to 16	12	12	12	24		24	16	16	16	32		32
MTZ2 20	24	24	24	24	24	42	32	32	32	32	32	56
MTZ2 25		24	24	24	24			32	32	32	32	
MTZ2 32		36	36	36	36			48	48	48	48	
MTZ2 40		42	42	42	42			56	56	56	56	
MTZ3 40 to 50		72		72				96		96		
MTZ3 63		72		72				96		96		

Note: the minimum order is 6 parts.



Electrical diagrams

MasterPacT MTZ1 fixed and drawout devices

The diagram is shown with circuits de-energized, all devices open, connected and charged and relays in normal position.

Power

Control unit

Indication contacts

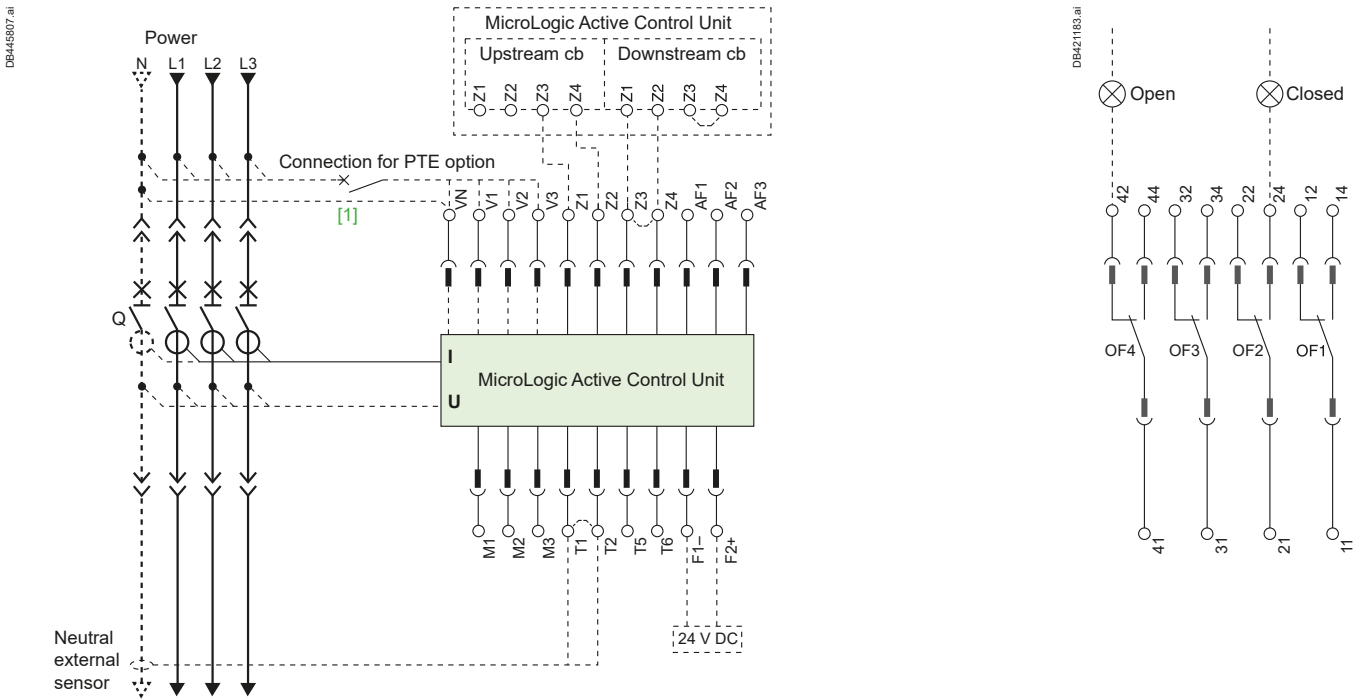

Remote operation

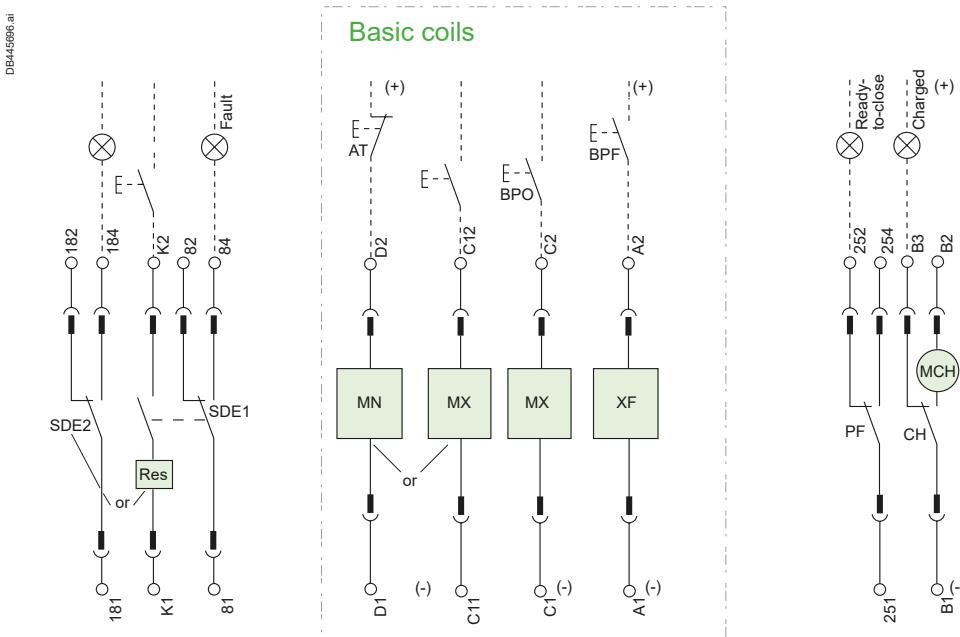

Note: Maximum length of the two wires cables between A2-A3 / C2-C3 / C12-C13: 5 m.
 The maximum lengths of the wiring between the AC/DC power supply and voltage release terminals A1-A3 / C1-C3 / C11-C13 / D1-D2 are given on page C-18.
[1] For 3 poles MasterPacT MTZ circuit breaker in power system with neutral distributed, the neutral shall be connected to the VN terminal of MicroLogic Active and ENVT configured to "Yes" to ensure the quality of power measurement.

Electrical diagrams

MasterPacT MTZ1 fixed and drawout devices

Terminal block marking

CE3	CE2	Com	UC1	UC2	SDE2	UC4	UC3	SDE1	MN	MX	XF	PF	MCH
334	324	• F2+ [1] or • F1-	T6	M1	182	V3	VN	84	D2	C2	A2	254	B2
332	322		Z3	Z4		V2		82		C3	A3	252	B3
331	321		Z1	Z2	181	V1		81	D1	C1	A1	251	B1



OF4	OF3	OF2	OF1	CD2	CD1	CE1	CT1
44	34	24	14	824	814	314	914
42	32	22	12	822	812	312	912
41	31	21	11	821	811	311	911



Indication contacts terminal block

OF4 / OF3 / OF2 / OF1: ON/OFF indication contacts OF

Chassis contacts terminal block

CD2 / CD1: disconnected position contacts
CE3 / CE2 / CE1: connected position contacts
CT1: test position contacts

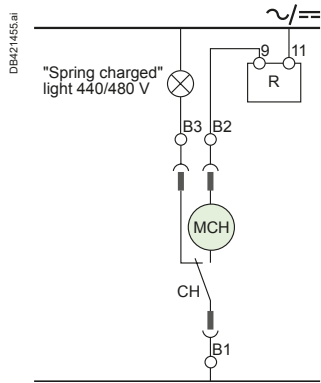
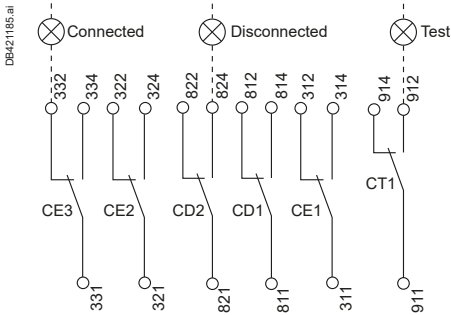

Spring charging motor 440/480 V AC (380 V motor + additional resistor)

Control unit terminal block

Com: Fixed, F2+ F1- (as standard) or ULP port (as option)
 Drawout, F2+ F1- (as standard) or ULP port (as option)

UC1: Z1-Z4 zone selective interlocking

UC2: T1, T2 = neutral external sensors

UC3: Voltage connector (must be connected to the neutral with a 3P circuit breaker)

UC4: External Voltage Connector (PTE option)

Remote operation terminal block

SDE2: fault-trip indication contact

or
Res: remote reset

SDE1: fault-trip indication contact (supplied as standard)

MN: standard undervoltage release
 or
2nd MX: standard opening voltage release

MX: standard opening voltage release

XF: standard closing voltage release

PF: ready-to-close contact

MCH: electric motor

□ Drawout device only.

■ SDE1, OF1, OF2, OF3, OF4 supplied as standard.

○ interconnections (only one wire per connection point).

[1] The connection of the +/- of the power supply either on terminals F1/F2 of MicroLogic Active or on the +/- terminals of the ULP port must be strictly respected. Inverting the polarities may damage the device.



Electrical diagrams

MasterPacT MTZ2/MTZ3 fixed and drawout devices

The diagram is shown with circuits de-energized, all devices open, connected and charged and relays in normal position.

Power

Control unit

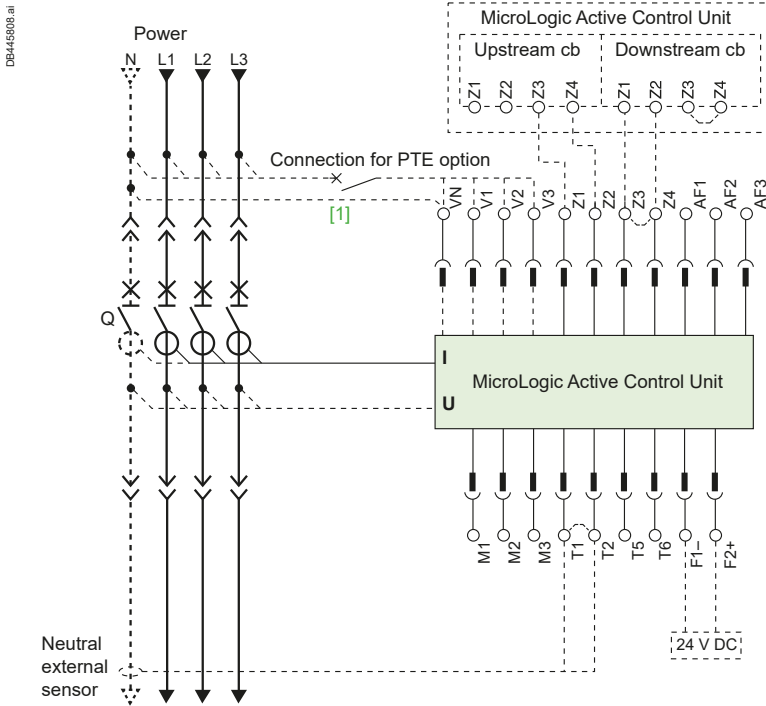

Remote operation

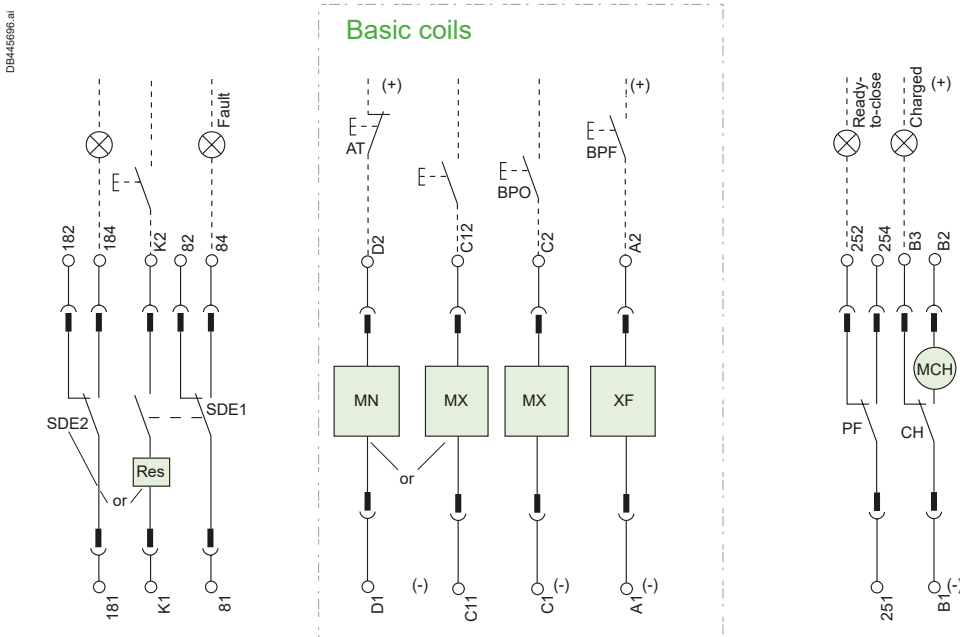

Note: Maximum length of the two wires cables between A2-A3 / C2-C3 / C12-C13: 5 m.

The maximum lengths of the wiring between the AC/DC power supply and voltage terminals A1-A3 / C1-C3 / C11-C13 / D1-D2 are given on page C-18.

[1] For 3 poles MasterPacT MTZ circuit breaker in power system with neutral distributed, the neutral shall be connected to the VN terminal of MicroLogic Active and ENVT configured to "Yes" to ensure the quality of power measurement.

Electrical diagrams

MasterPacT MTZ2/MTZ3 fixed and drawout devices

Indication contacts

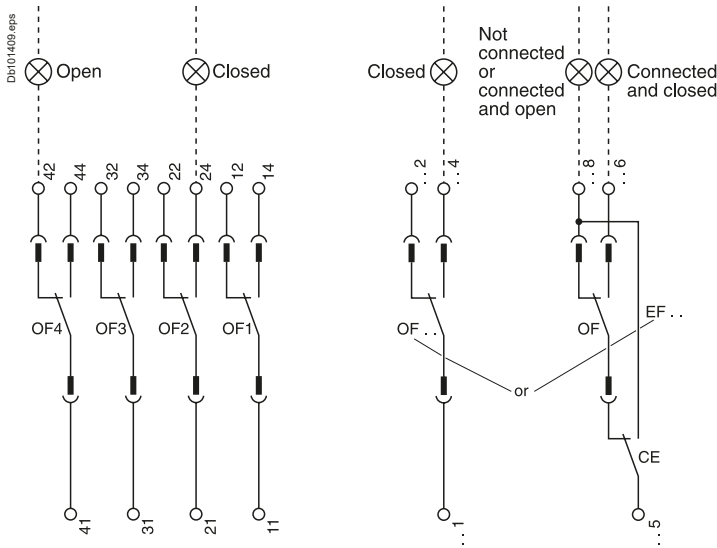

Chassis contacts

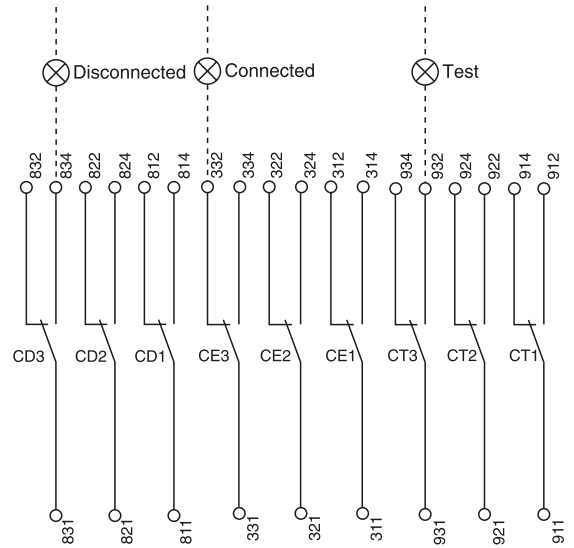

Control unit terminal block

Com: Fixed, F2+ F1- (as standard) or ULP port (as option)
 Drawout, F2+ F1- (as standard) or ULP port (as option)

UC1: Z1-Z4 zone selective interlocking

UC2: T1, T2 = neutral external sensors

UC3: Voltage connector (must be connected to the neutral with a 3P circuit breaker)

UC4: External Voltage Connector (PTE option)

Remote operation terminal block

- SDE2**^[1]: fault-trip indication contact
- or**
- Res:** remote reset
- SDE1**^[1]: fault-trip indication contact (supplied as standard)
- MN:** diagnostic or standard undervoltage release
- or**
- 2ndMX:** standard opening voltage release
- MX:** standard opening voltage release
- XF:** standard closing voltage release
- PF:** ready-to-close contact
- MCH:** electric motor

[1] Available with MTZ2 HF and MTZ2 HH.

Indication contacts

OF4:	ON/OFF indication contacts OF	OF24 or EF24	ON/OFF indication contacts OF or connected/closed contacts EF
OF3		OF23 or EF23	
OF2		OF22 or EF22	
OF1		OF21 or EF21	
		OF14 or EF14	
		OF13 or EF13	
		OF12 or EF12	
		OF11 or EF11	

Chassis contacts

CD3	disconnected	CE3	connected	CT3	test position
CD2	position	CE2	position	CT2	contacts
CD1	contacts	CE1	contacts	CT1	
or		or		or	
CE6	connected	CT6	test position	CE9	connected
CE5	position	CT5	contacts	CE8	position
CE4	contacts	CT4		CE7	contacts
				or	
				CD6	disconnected
				CD5	position
				CD4	contacts



Electrical diagrams

24 V DC external power supply AD module

- With MicroLogic, it is recommended to connect 24 V DC external power supply (AD module) to the MicroLogic control unit (F1- F2+) in order to help
 - Keep available the display and the energy metering, even if Current < 20 % In.
 - Use the display even if the circuit breaker is open or not supplied (for the exact conditions of use, see the "electrical diagrams" part of this catalog)
 - Display fault currents after tripping
 - Modify settings when the circuit breaker is open (OFF position)
- The same 24 V DC external power supply cannot be used for the MicroLogic control unit and the communication devices (IFE, IFM, I/O, FDM).
- The same 24 V DC external power supply can be used for the MicroLogic control unit.
- The 24 V DC external power supply (AD module) for the MicroLogic control unit (F1- F2+) is not required for basic protections LSIG.

Note: in case of using the 24 V DC external power supply (AD module), maximum cable length between 24 V DC (G1, G2) and the control unit (F1-, F2+) must not exceed 10 meters.

Connection

The maximum length for each conductor supplying power to the control unit module is 10 m.

Do not ground F2+, F1-, or power supply output:

- The positive terminal (F2+) on the control unit must not be connected to ground
- The negative terminal (F1-) on the control unit must not be connected to ground
- The output terminals (- and +) of the 24 V DC power supply must not be grounded.

Reduce electromagnetic interference:

- The input and output wires of the 24 V DC power supply must be physically separated as much as possible
- The 24 V DC wires (output of the 24 V DC power supply) shall be twisted together
- The 24 V DC wires (output of the 24 V DC power supply) must cross all power cables perpendicularly
- Power supply conductors must be cut to length. Do not loop excess conductor.

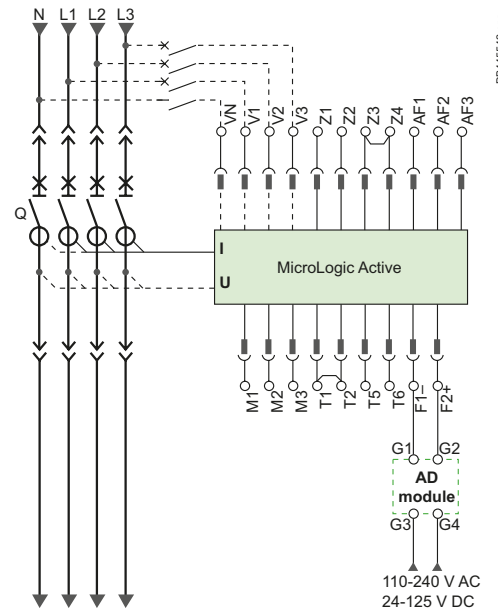

DB44542.eps



E

Integrate in Special Applications Source-Changeover Systems

Presentation	F-2
Mechanical interlocking.....	F-3
Electrical interlocking IVE unit.....	F-5
Controller installation	F-6
Controllers.....	F-7
BA controller	F-8
UA controller	F-9

Other chapters
"Select a Circuit Breaker", page A-1
"Select a MicroLogic Active Control Unit", page B-1
"Customize your Circuit Breaker with Accessories", page C-1
"Integrate in Smart Panels - Architecture and Systems", page D-1
"Integrate in a Switchboard", page E-1
"Services", page G-1
"Order your Circuit Breaker", page H-1

PE191613-50.eps



6555F-117.eps



F

In installations requiring a high level of availability two redundant power supplies are generally used. The main supply can at any time be replaced by an emergency supply in case of power interruption. The replacement source can be an emergency power generator set or another low voltage network.

In complex low voltage architectures, up to three independent power supplies may be used to secure the installation. More than three independent sources can even be used for specific applications.

Changeover systems are required to quickly and safely switch between the power sources.

There are three ways to switch between the sources:

- Manually
- Automatically
- Remotely

Manual source-changeover system or **M**: Manual Transfer Switching Equipment

The simplest way to switch between the power sources. The closing and opening operations of the circuit breakers or switches are performed by the operators. The time required to switch between the sources is variable.

System

Two or three mechanically interlocked circuit breakers or switch-disconnectors.

Applications

Small commercial buildings and small and medium industrial activities where the need for continuity of service is significant but not a priority.

Automatic source-changeover system or **A**: Automatic Transfer Switching Equipment

A controller is added to automatically control the switching operations. This can be done using the standard BA, UA controllers and the associated IVE electrical interlocking unit. The solution is limited to two circuit breakers or two switch-disconnectors.

The automatic switching sequence is initiated by detecting the loss of the power supply. It can also be initiated by the operators.

System

Two mechanically interlocked circuit breakers or switch disconnectors, associated with one BA or UA controller and the IVE electrical interlocking unit.

Applications

Large infrastructures.

Schneider Electric offers source change-over systems based on MasterPacT MTZ devices.

They are made of up to 3 circuit breakers or switch-disconnectors linked by an electrical interlocking system that may have different configurations. Moreover, a mechanical interlocking system must be added to protect against electrical malfunctions or incorrect manual operations. In addition, a controller can be used to automatically control the source transfer. The following pages present the different solutions for mechanical and electrical interlocking and associated controllers.

For implementing the mechanical interlocking 2 different possibilities are offered:

- Interlocking with rods
- Interlocking with cables

Interlocking of two devices using connecting rods

The two devices must be installed one above the other.

For MasterPacT MTZ1 only associations between similar type devices are allowed (2 fixed or 2 drawout devices). Mixed associations between MasterPacT MTZ1 and MasterPacT MTZ2 or MTZ3 devices of different types (fixed or drawout) are not possible.

For MasterPacT MTZ2 and MTZ3, all mixed associations between fixed type and drawout type devices are possible.

Installation

This function requires:

- An adaptation fixture on the right side of each circuit breaker or switch-disconnector
- A set of connecting rods with no-slip adjustments
- A mechanical operation counter CDM (mandatory)

The adaptation fixtures, connecting rods, circuit breakers and switch-disconnectors are supplied separately, ready for assembly by the customer.

The maximum vertical distance between the fixing plates is 900 mm.

Interlocking of two or three devices using cables

For cable interlocking, the circuit breakers can be installed either one above the other or side-by-side.

All mixed associations between MasterPacT MTZ1, MTZ2, MTZ3 fixed type and drawout type devices are possible.

Interlocking between two MasterPacT MTZ1, MTZ2, MTZ3 devices

This function requires:

- An adaptation fixture on the right side of each device
- A set of cables without slip adjustments
- A mechanical operation counter CDM (mandatory)

The maximum distance between the fixing planes (vertical or horizontal) is 2000 mm.

Interlocking between three MasterPacT MTZ1, MTZ2, MTZ3 devices

This function requires:

- A specific adaptation fixture installed on the right side of each device
- Two sets of cables without slip adjustments
- A mechanical operation counter CDM (mandatory)

The maximum distance between the fixing planes (vertical or horizontal) is 1000 mm.

Installation

The adaptation fixtures, sets of cables and circuit breakers or switch-disconnectors are supplied separately, ready for assembly by the customer.

Installation conditions for cable interlocking systems:

- Cable length: 2.5 m
- Cable bending radius: greater than 100 mm
- Maximum number of curves: 3.

Note: for cable length higher than 2.5 m please consult us before ordering the circuit breakers for a customized solution.

Choice criteria

In the applications where the continuity of service is critical(*) (Data Centers, airports, hospitals, marine, oil&gas, process industry, ...) the mechanical interlocking by rods and the drawout version devices is strongly recommended.

Mechanical interlocking by rods is preferred as less energy is consumed by friction, so it has less effect on the circuit breaker closing energy.

In terms of breaker mounting type, the drawout version is preferred as:

- It mechanically isolates of the circuit breaker from possible external stress on the terminals by having a flexible connection at the clusters level
- It allows simple and total access for periodic maintenance
- It allows quick replacement of the device if necessary.

When not possible, cable interlocking or fixed versions can be used, but the installation rules detailed in the 2 sections below must be strictly respected and mainly:

- The busbars or the cables used for the power connections must apply no stress on the circuit breakers terminals. Their weight must be supported by the switchboard frame.

[1] For more details please contact your local support.

- Please refer to the "Switchboard integration - Installation rules – Power connection" section in this catalog as well as to the Data Bulletin "Installation of Fixed MasterPacT NW Circuit Breakers in Electrical Equipment – Class 0613" available on www.se.com for more details.



PB113431 eps

Interlocking of two MasterPacT MTZ1 or MTZ2 / MTZ3 circuit breakers using connecting rods

F

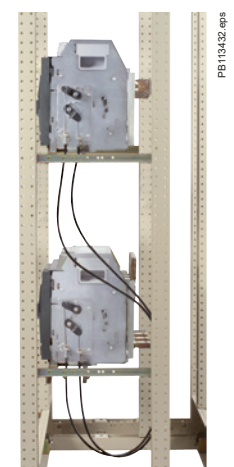

PE113432 eps

Interlocking of two MasterPacT circuit breakers using cables



100975E/PS

Possible association between MasterPacT MTZ1, MTZ2, MTZ3

Key interlocking

Interlocking using keylocks is very simple and makes it possible to interlock two or more devices that are physically distant or that have very different characteristics.

Interlocking system

Each device is equipped with an identical keylock and the key is captive on the closed (ON) device. A single key is available for all devices. It is necessary to first open (OFF position) the device with the key before the key can be withdrawn and used to close another device.

A system of wall-mounted captive key boxes makes a large number of combinations possible between many devices.

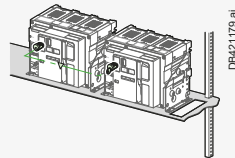

Mechanical interlocking using connecting rods

MasterPacT MTZ1:

2 MasterPacT MTZ1 fixed type or drawout type. Association between fixed type and drawout type MTZ1 devices is not possible nor combinations between MTZ1 and MTZ2 or MTZ3.

MasterPacT MTZ2 and MTZ3:

All mixed associations between fixed type and drawout type devices are possible.

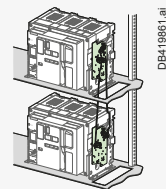

Mechanical interlocking by cables

All mixed associations between MasterPacT MTZ1, MTZ2, MTZ3 fixed type and drawout type devices are possible.

Note: 3 devices mechanical interlocking is applicable only to MTZ2 and MTZ3.

Vertical

Horizontal

2 devices MTZ1 - MTZ2 - MTZ3

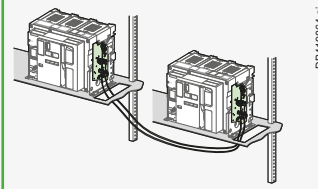
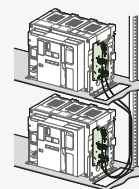

3 devices MTZ2 - MTZ3

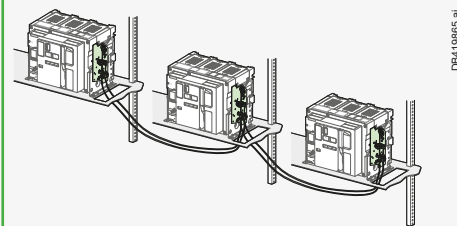
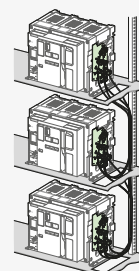

F

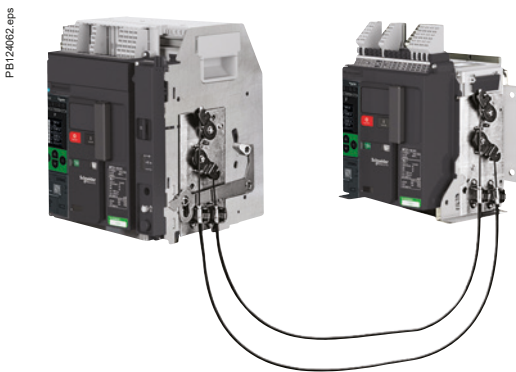

PB124062.e/ps

Integrate in Special Applications - Source-Changeover Systems

Electrical interlocking IVE unit

IVE electrical interlocking unit

Electrical interlocking between MasterPacT MTZ1, MTZ2, and MTZ3 circuit breakers can be done using the IVE Electrical interlocking unit or using dedicated wiring. The IVE unit is suitable for two circuit breakers or two switch-disconnectors only. For three devices, dedicated wiring is required to perform the electrical interlocking.

Characteristics of the IVE unit

- External connection terminal block:
 - **Inputs:** status of the SDE contacts on the "N" (Normal) and "R" (Replacement) source circuit breakers
 - **Output:** circuit breaker control signals
- Two connectors for the two "N" and "R" source circuit breakers:
 - **Inputs:** - status of the OF contacts on each circuit breaker (ON or OFF) - status of the SDE contacts on the "N" and "R" source circuit breakers
 - **Outputs:** power supply for operating mechanisms
- Control voltage:
 - 24 to 250 V DC
 - 48 to 415 V 50/60 Hz - 440 V 60 Hz.

The IVE unit control voltage must be same as for the circuit breaker operating mechanisms.

Necessary equipment for MasterPacT MTZ1, MTZ2, MTZ3, each circuit breaker must be equipped with:

- A remote-operation system made up of:
 - MCH gear motor
 - MX or MN opening voltage release
 - XF closing voltage release
 - PF ready-to-close contact
 - CDM mechanical operation counter
- An available OF contact
- One to three CE connected-position contacts (carriage switches) on drawout circuit breakers (depending on the installation).



PB110174.eps

DB413979.ai

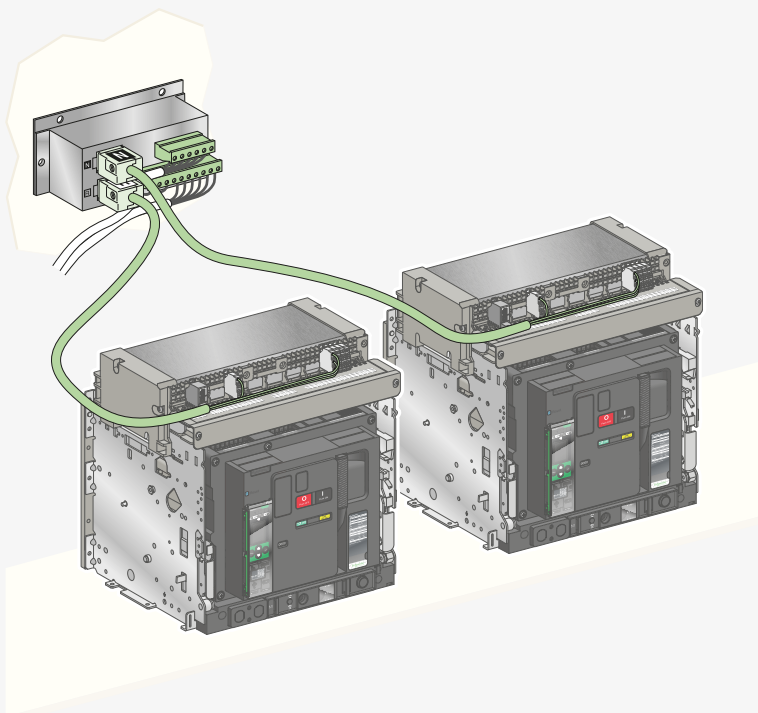

Note: After either manual or fault tripping the manual acknowledgement of the circuit breaker is required.

1 normal source - 1 replacement source

DB419718.ai

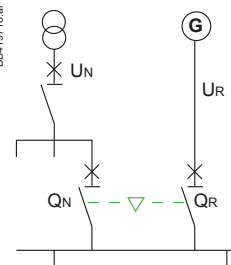

QN	QR
0	0
1	0
0	1

2 sources with coupler on busbars

DB419719.ai

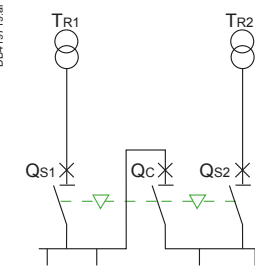

Qs1	Qc	Qs2
0	0	0
1	0	1
1	1	0
0	1	1
1	0	0 [1]
0	0	1 [1]

[1] possible by forcing operation

2 normal sources - 1 replacement source

DB419720.ai

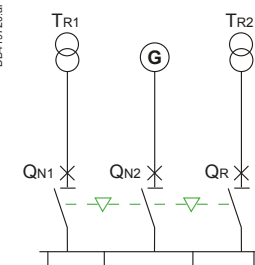

QN1	QN2	QR
0	0	0
1	1	0
0	0	1
1	0	0
0	1	0



PB100857_SE.eps

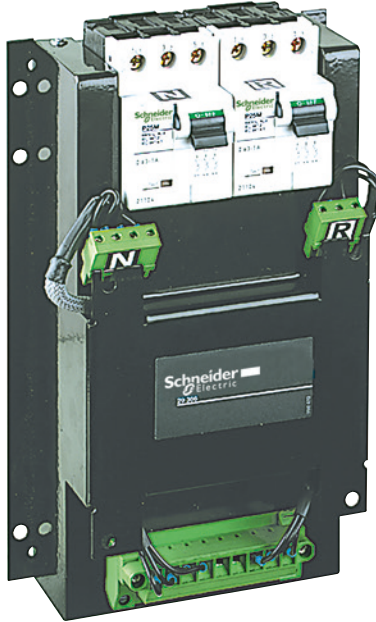

ACP control plate

The control plate provides in a single unit:

- Protection for the BA or UA controller with two highly limiting P25M circuit breakers (infinite breaking capacity) for power drawn from the AC source
- Control of circuit breaker ON and OFF functions via two relay contactors
- Connection of the circuit breakers to the BA or UA controller via a built-in terminal block.

Control voltages

- 110 V 50/60 Hz.
- 220 to 240 V 50/60 Hz.
- 380 to 415 V 50/60 Hz and 440 V 60 Hz.

The same voltage must be used for the ACP control plate, the controller and the circuit breaker operating mechanisms.

Installation

Connection between the ACP control plate and the IVE unit may use:

- Wiring done by the installer
- Prefabricated wiring (optional)

Installation of the BA and UA controllers

The BA and UA controllers may be installed in one of two manners:

- Directly mounted on the ACP control plate
- Mounted on the front panel of the switchboard
- If the length of the connection between the controller and the control plate (ACP) is less than or equal to 1 m, the connecting cable ref. 29368 can be ordered as an optional extra. Cables longer than 1 m, but not longer than 2 m will be the responsibility of the installer.

F

DB419723.ai

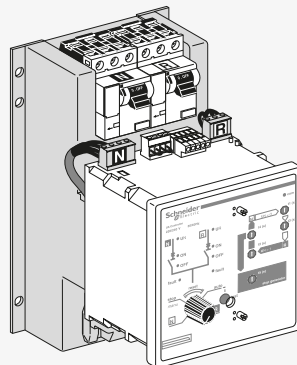

Mounting on the ACP control plate

DB419724.ai

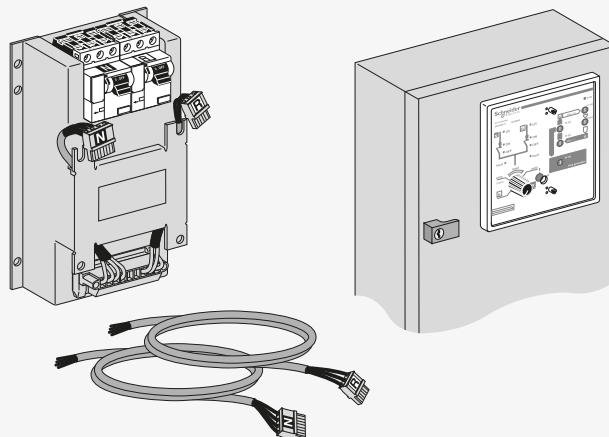

Mounting on the front panel of the switchboard

By combining a remote-operated source-changeover system with an integrated BA or UA automatic controller, it is possible to automatically control source transfer following user-selected sequences. These controllers can be used on source-changeover systems that include two circuit breakers or switch-disconnectors. For source-changeover systems that include three circuit breakers, the automatic control diagram must be prepared by the installer as a complement to diagrams provided in the “electrical diagrams” section of this catalog.

Controller		BA	UA			
4-position switch						
Automatic operation		●	●			
Forced operation on “Normal” source		●	●			
Forced operation on “Replacement” source		●	●			
Stop (both “Normal” and “Replacement” sources off)		●	●			
Automatic operation						
Monitoring of the “Normal” source and automatic transfer		●	●			
Generator set startup control			●			
Delayed shutdown (adjustable) of generator set			●			
Load shedding and reconnection of non-priority circuits			●			
Transfer to the “Replacement” source if one of the phases of the “Normal” source is absent			●			
Test						
By opening the P25M circuit breaker supplying the controller		●				
By pressing the test button on the front of the controller			●			
Indications						
Circuit breaker status indication on the front of the controller: on, off, fault trip		●	●			
Automatic mode indicating contact		●	●			
Other functions						
Selection of type of “Normal” source (single-phase or three-phase) [1]			●			
Voluntary transfer to “Replacement” source (for example, energy management commands)		●	●			
During peak-tariff periods (energy management commands) forced operation on “Normal” source if “Replacement” source not operational			●			
Additional contact (not part of controller)						
Transfer to “Replacement” source only if contact is closed (for example, used to test the frequency of UR).		●	●			
Setting of maximum startup time for the replacement source			●			
Power supply						
Control voltages [2]	110 V 50/60 Hz	●	●			
	220 to 240 V 50/60 Hz	●	●			
	380 to 415 V 50/60 Hz and 440 V 60 Hz	●	●			
Operating thresholds						
Undervoltage	0.35 Un ≤ voltage ≤ 0.7 Un	●	●			
Phase failure	0.5 Un ≤ voltage ≤ 0.7 Un		●			
Voltage presence	voltage ≥ 0.85 Un	●	●			
IP degree of protection (EN 60529) and IK degree of protection against external mechanical impacts (EN 50102)						
Front	IP40	●	●			
Side	IP30	●	●			
Connectors	IP20	●	●			
Front	IK07	●	●			
Characteristics of output contacts (dry, volt-free contacts)						
Rated thermal current (A)	8					
Minimum load	10 mA at 12 V					
Output contacts	Position of the Auto/Stop switch	●	●			
	Load shedding and reconnection order		●			
	Generator set start order		●			
		AC		DC		
Utilization category (IEC/EN 60947-5-1)	AC-12	AC-13	AC-14	AC-15	DC-12	DC-13
Operational current (A)	24 V	8	7	5	5	8
	48 V	8	7	5	5	2
	110 V	8	6	4	4	0.6
	220/240 V	8	6	4	3	-
	250 V	-	-	-	-	0.4
	380/415 V	5	-	-	-	-
	440 V	4	-	-	-	-
	660/690 V	-	-	-	-	-



DBA403810.eps



DBA403810.eps



[1] For example, 220 V single-phase or 220 V three-phase.
 [2] The controller is powered by the ACP control plate. The same voltage must be used for the ACP plate, the IVE unit and the circuit breaker operating mechanisms. If this voltage is the same as the source voltage, then the “Normal” and “Replacement” sources can be used directly for the power supply. If not, an isolation transformer must be used.

BA controller

The BA controller is used to create simple source-changeover systems that switch from one source to another depending on the presence of voltage U_N on the "Normal" source. It is generally used to manage two permanent sources and can control ComPacT NS, ComPacT NSX and MasterPacT MTZ circuit breakers and switch-disconnectors.

DE 403841 eps



DE 403838 eps

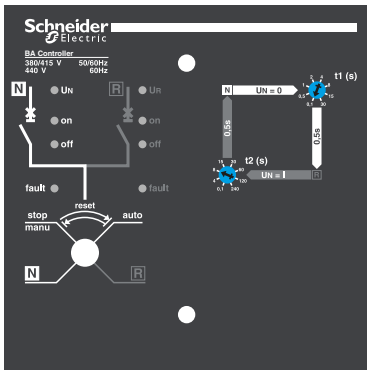

Front of the BA controller

Operating modes

A four-position switch can be used to select:

- Automatic operation
- Forced operation on the "Normal" source
- Forced operation on the "Replacement" source
- Stop (both "Normal" and "Replacement" sources off)

Setting the time delays

Time delays are set on the front of the controller.

t1. Delay between detection that the "Normal" source has failed and the transmission of the order to open the "Normal" source circuit breaker (adjustable from 0.1 to 30 seconds).

t2. Delay between detection that the "Normal" source has returned and the transmission of the order to open the "Replacement" source circuit breaker (adjustable from 0.1 to 240 seconds).

Circuit breaker commands and status indications

The status of the circuit breakers is indicated on the front of the controller.

- ON, OFF, fault.

A built-in terminal block can be used to connect the following input/output signals:

- Inputs:
 - Voluntary order to transfer to "Replacement" source (for example, for special tariffs, etc.)
 - Additional control contact (not part of the controller). Transfer to the "Replacement" source takes place only if the contact is closed (for example, used to test the frequency of U_R , etc.)
- Outputs:
 - Indication of operation in automatic or stop mode given by changeover contacts.

Test

It is possible to test the operation of the BA controller by turning OFF (opening) the P25M circuit breaker for the "Normal" source and thus simulating a failure of voltage U_N .

The UA controller is used to create a source-changeover system integrating the following automatic functions:

- Transfer from one source to another depending on the presence of voltage U_N on the “Normal” source
 - Startup of an engine generator set
 - Shedding and reconnection of non-priority circuits
 - Transfer to the “Replacement” source if one of the phases on the “Normal” source fails.
- The UA controller can control ComPacT NS, ComPacT NSX and MasterPacT MTZ devices.

Operating modes

A four-position switch can be used to select:

- Automatic operation
- Forced operation on the “Normal” source
- Forced operation on the “Replacement” source
- Stop (both “Normal” and “Replacement” sources off, then manual operation)

Setting the time delays

Time delays are set on the front of the controller.

- t1.** Delay between detection that the “Normal” source has failed and the transmission of the order to open the “Normal” source circuit breaker (adjustable from 0.1 to 30 seconds).
- t2.** Delay between detection that the “Normal” source has returned and the transmission of the order to open the “Replacement” source circuit breaker (adjustable from 0.1 to 240 seconds).
- t3.** Delay following opening of QN with load shedding and before closing of QR (adjustable from 0.5 to 30 seconds).
- t4.** Delay following opening of QR with load reconnection and before closing of QN (adjustable from 0.5 to 30 seconds).
- t5.** Delay for confirmation that U_N is present before shutting down the engine generator set (adjustable from 60 to 600 seconds).
- t6.** Delay before startup of the engine generator set (120 or 180 seconds).

Commands and indications

Circuit breaker status indications on the front of the controller:

- ON, OFF, fault.

A built-in terminal block can be used to connect the following input/output signals:

- Inputs:
 - Voluntary order to transfer to “Replacement” source (for example, for special tariffs, etc.)
 - Additional control contact (not part of the controller). Transfer to the “Replacement” source takes place only if the contact is closed (for example, used to test the frequency of UR, etc.)
- Outputs:
 - Control of an engine generator set (ON / OFF)
 - Shedding of non-priority circuits
 - Indication of operation in automatic mode given by changeover contacts.

Distribution-system settings

Three switches are used to:

- Select the type of “Normal” source, whether single-phase or three-phase (for example, 240 V single-phase or 240 V three-phase)
- Select whether to remain on the “Normal” source if the “Replacement” source is not operational during operation on special tariffs
- Select the maximum permissible startup time for the engine generator set during operation on special tariffs (120 or 180 seconds).

Test

A pushbutton on the front of the controller can be used to test the transfer from the “Normal” source to the “Replacement” source, then to test the return to the “Normal” source. The test lasts approximately three minutes.



DB-403842.eps

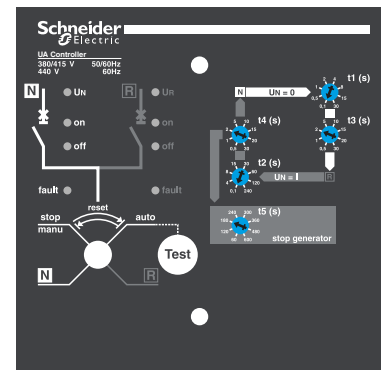

Front of the UA controller

DB-403837.eps

F

F

Services

Overview..... G-2



Other chapters

- "Select a Circuit Breaker", page A-1
- "Select a MicroLogic Active Control Unit", page B-1
- "Customize your Circuit Breaker with Accessories", page C-1
- "Integrate in Smart Panels - Architecture and Systems", page D-1
- "Integrate in a Switchboard", page E-1
- "Integrate in Special Applications Source-Changeover Systems", page F-1
- "Order your Circuit Breaker", page H-1

Decarbonizing and electrifying faster

with Schneider Electric Services, your lifelong trusted partner

For a sustainable and decarbonized world, our passionate Consultants, Services Experts and Partners are dedicated **helping you in your electrification journey** and **extending the life of your assets while making your operations safe, efficient and resilient every day.**

- **6,500+ experts and +230 consultants** in electrical and automation asset management services
- Worldwide presence in **140** countries within **430** Service centers
- **15+** Connected Services Hubs to provide valuable data-driven insights to more than **6,000** customers
- **2000+ experts** in Sustainability and Energy procurement operating

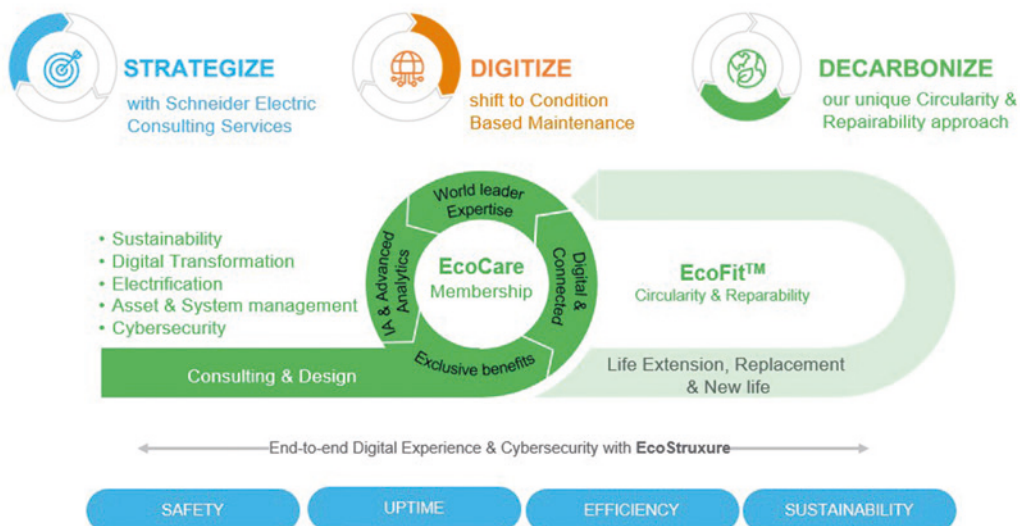



EcoCare Membership **READY**

Unlock today the potential of your connectable asset with next generation Services Membership

Optimizing the efficiency of your electrical distribution must be your first priority, from day one. By becoming an EcoCare Member, you gain access to remote monitoring capabilities which can help detect abnormal issues that might potentially impact the uptime of your equipment during its early years. By identifying these issues early on, you can proactively implement condition-based maintenance strategies as your equipment ages, ensuring a smooth and uninterrupted operation.

EcoCare membership is an innovative services plan that helps reduce downtime and related costs. It utilizes IoT sensors to gather critical data like temperature, humidity, insulation, and moisture. This data is then processed by Schneider Electric's advanced EcoStruxure IoT platform, enabling our Connected Services Hub Team to provide 24/7 remote monitoring and alarming for EcoCare members' assets. In case of emergencies, EcoCare members receive exclusive priority access to Schneider Electric expertise and interventions, defined by exclusive Service Level Agreement.

EcoCare helps:

- Reduce by **up to 75 %** electrical failure risk and unplanned downtime
- Reduce by **up to 40 %** on-site maintenance activities and planned downtime costs
- Extend the lifespan of their equipment and **avoid carbon emissions**



		EcoCare Essential	EcoCare Advanced	EcoCare+ Advanced
Support to operations	mySchneider portal Technical and Emergency support Customer Success Management	○	○	○
Workforce empowerment	Access to online training courses, online and on-site instructor led training at members rates	○	○	○
Exclusive Benefits	Members rates for local events and other services	○	○	○
Monitor & Optimize	24/7 Monitoring and alarming	○	○	○
	Consultancy by our experts with advanced analytics	-	○	○
	Partial discharge monitoring for MV Switchgear	-	Option	Option
	Advanced analytics for Oil Transformers	-	Option	Option
Extended warranty		Option	Option	○
On-site maintenance	Preventive maintenance visit	Option	Option	Option
	Condition-based mainenance	-	-	○
Parts	Spare parts	Member rates	Member rates	○



EcoConsult actionable insight

Be future-ready with EcoConsult

Our Consultants evaluate and map your electrical and automation assets and systems with best-in-class Software and Digital Twin technologies. The result? Your installation is safer, more resilient, efficient and sustainable.

up to 30 % reduce OpEx for asset management

up to 35 % reduce electrical energy losses

up to 15 % reduce electrical utility bill (power factor improvement)

up to 20 % improve electrical system and reliability

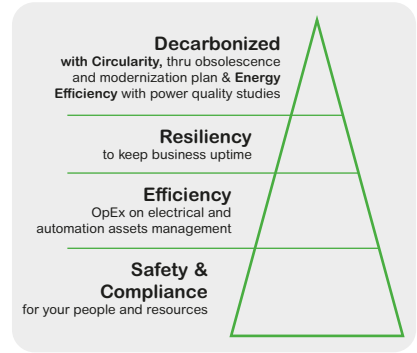

We provide actionable insights and deliver on critical business outcomes



EcoConsult Consulting Services portfolio

<p>Electrical Digital Twin Digitized Electrical single line diagram</p>	<p>Audit for Power Remote & Onsite assets and system health check</p>	<p>Audit for Power Quality Power factor, active & reactive power & harmonics</p>	<p>Audit for Power monitoring Metering and monitoring plan design</p>	<p>Audit for Industrial Automation Improve Lifecycle Management for Industrial Automation Assets</p>	<p>System studies & Design Electrical network studies (short-circuit, protection, coordination, arc flash, motor starting..) & new installation design</p>	<p>Audit for Energy Efficiency Remote & Onsite audit to help reduce energy consumption</p>
--	--	---	--	---	---	---

mySchneider CONSULTING REPORT WITH OPPORTUNITIES & REMINDERS, FOLLOW-UP



EcoFit™ Life extension

Electrical distribution equipment modernization with ECOFIT™ MasterPacT MTZ

Equipment aging increases operating costs:

- Increase in maintenance frequency
- Increase in corrective maintenance
- Availability and cost of spare parts

Schneider Electric helps you to upgrade your equipment and your installation.

Increase lifetime of your installation with a cost effective solution and benefit from the latest product innovation.

ECOFIT™ Masterkit and Plug and Play MasterPacT MTZ solution enables you to:

- Upgrade your equipment with limitation of power interruption time.
- Optimize your maintenance service costs and limit your investments.
- Give a boost to the electrical switchboard for efficient operation and energy management with the new MicroLogic Active.
- Maintain compliance with evolving industry standards and legislation.
- Benefit 3-years warranty including parts, on-site labor costs and travel costs according to Schneider Electric commercial conditions.

ECOFIT™ MasterPacT Plug and Play

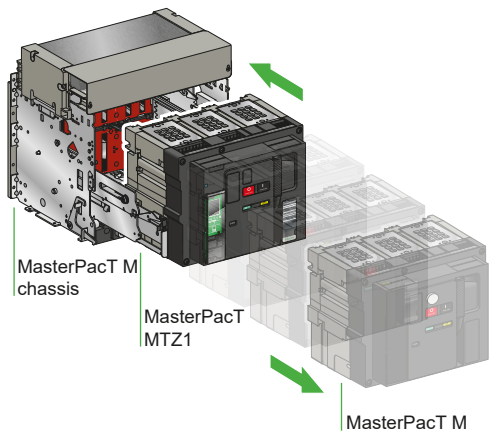

ECOFIT™ MasterPacT Plug and Play

A simple solution, easy to implement for a minimum shutdown time. It allows you to upgrade your equipment by substituting an existing MasterPacT M for a MasterPacT MTZ of the last generation. The MasterPacT MTZ is inserted in the existing MasterPacT M chassis.

- Very short on-site servicing times
- Solution particularly adapted for critical sites where shutdown time is key
- Shutdown of the entire installation is not required.
- Ideal for switchboards with no rear access
- No modification of switchboard door required
- Solution tested and complying with IEC 60947-2 standard

ECOFIT™ Masterkit

With the Masterkit offer, you have absolutely everything you need to replace an old MasterPacT M.

ECOFIT™ MasterPacT M Masterkit brings all benefits and the enhanced features of MasterPacT MTZ circuit breakers and accessories. The installation requires shut down to access to the busbars.

- No modification of power circuit connections required.
- No modification of switchboard door required (up to 3200 A).
- Solution tested and complying with IEC 60947-2 standard.

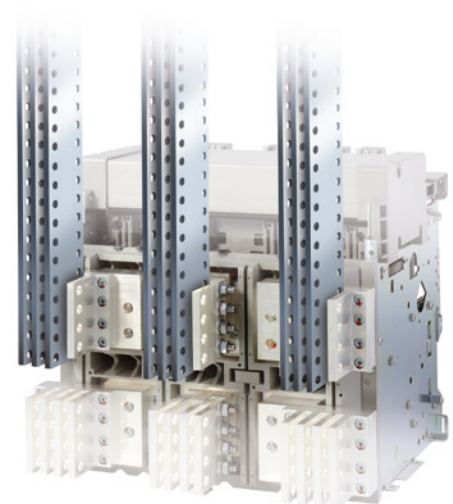

G

Order your Circuit Breaker

Order your MasterPacT MTZ through digital tools

Product Selector	H-2
MasterPacT MTZ Product Code.....	H-4



Other chapters

- "Select a Circuit Breaker", page A-1
- "Select a MicroLogic Active Control Unit", page B-1
- "Customize your Circuit Breaker with Accessories", page C-1
- "Integrate in Smart Panels - Architecture and Systems", page D-1
- "Integrate in a Switchboard", page E-1
- "Integrate in Special Applications Source-Changeover Systems", page F-1
- "Services", page G-1

Order your MasterPacT MTZ through digital tools Product Selector

To simplify and expedite the ordering of MasterPacT MTZ, four new tools are introduced:

- **Product Selector:** An online software tool embedded in Schneider website or in distributor’s website to help selecting the right product with its accessories.
- **Product code:** An alphanumeric code representing the selection of a MasterPacT MTZ circuit breaker. It simplifies the way to communicate the selection of a MasterPacT MTZ circuit breaker during ordering, sharing information and asking for help remotely.
- **MySE:** online ordering platform of Schneider for partners, offering most of our products.
- **Standard fixed configuration**

Product Selector

Product Selector aims at providing a fast, secure and smart way of selecting products. It includes the selection of the basic frame, control unit and accessories. Compared with the traditional way of filling up order forms or specifying customer functions, it brings the following benefits:

- **Easy access:** no login, direct access on Schneider website or on distributor’s website
- **Reliable:** compatibilities between core product and accessories are constantly tested
- **Wide coverage:** more than 130 ranges from Schneider are available (MasterPacT, ComPacT, TeSys, Acti 9, Altivar...)

Ordering process of MasterPacT MTZ with Product Selector

Non a MySE partner

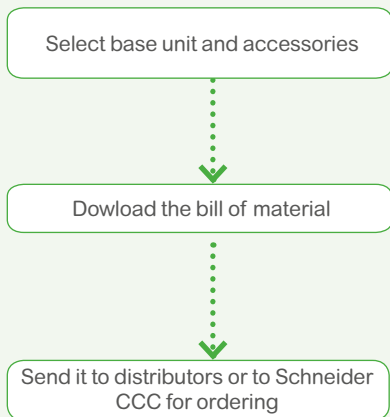

MySE partner

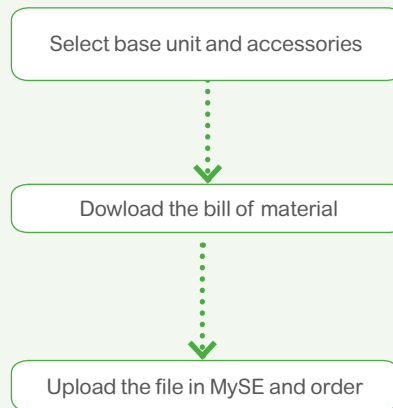

Order your MasterPacT MTZ through digital tools Product Selector

Go on the range page on www.se.com

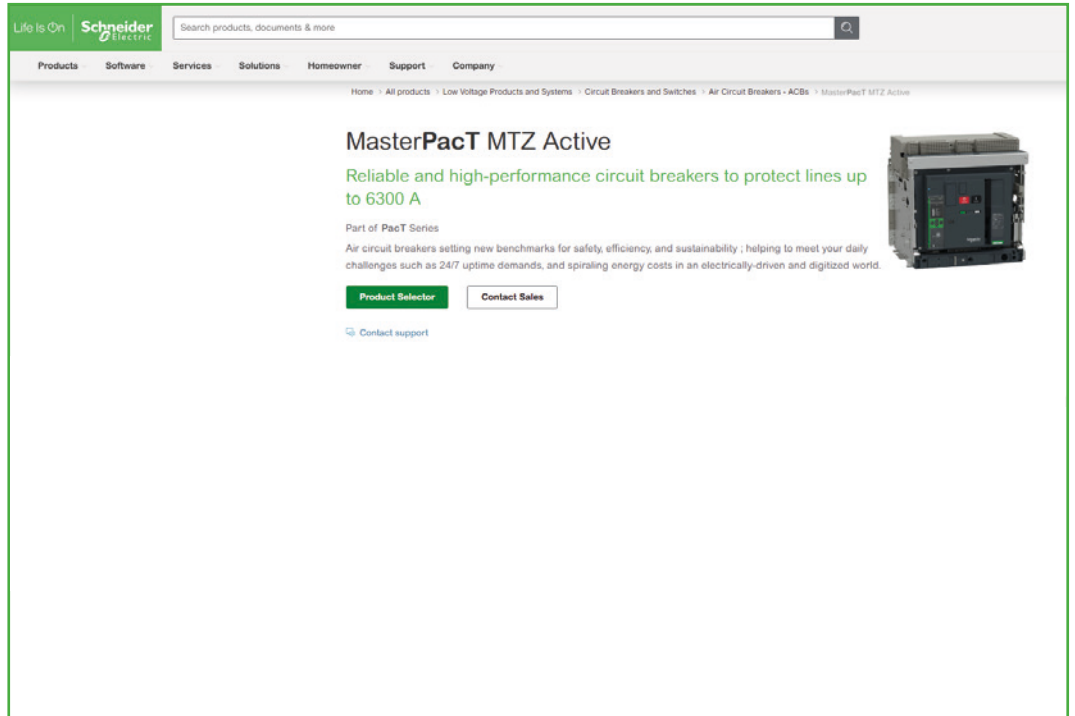

Click on Product Selector and run your selection

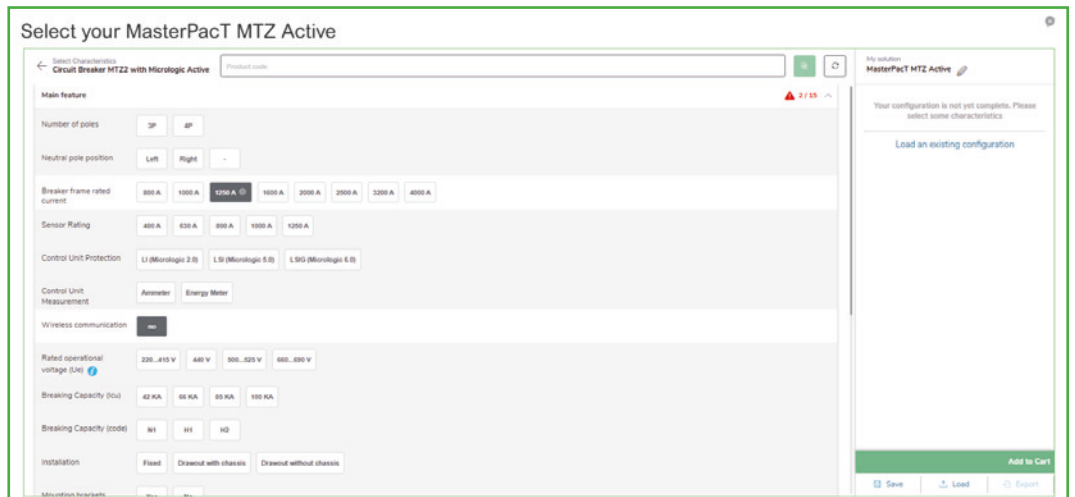

Note: You are always encouraged to use Product Selector to select the characteristics of your product. If you have difficulties accessing or using Product Selector, contact Schneider Electric Customer Care Centre or your Schneider Electric sales representatives for more information about MTZ ordering.

Order your MasterPacT MTZ through digital tools

MasterPacT MTZ Product Code

MasterPacT MTZ product code is an alphanumeric code representing the complete selection of a MasterPacT MTZ circuit breaker. It will be automatically generated for each MasterPacT MTZ circuit breaker after completing the selection through Product Selector. It will appear in the invoice and delivery documents as well as the labelling on the MasterPacT MTZ circuit breaker and the packaging.

MasterPacT MTZ product code brings the following benefits:

- Quick and unique identification of the initial selection of a circuit breaker can be achieved by reading the code on the physical products or other recordings
- Reordering of the same MasterPacT MTZ circuit breaker is simplified by communicating selection through product code
- Recording or sharing information about the initial selection of a circuit breaker is simplified
- Details of the coding rules can be accessed through CCC and there are some of the highlights:
 - All options of accessories are coded.
 - The minimum length of the code is 9 characters and the maximum length of the code is 33* characters depending on the choice of the accessories.
 - Capital letters, numbers and start sign ^[1] are used.

[1] The maximum length of the code may change due to future enrichment of the offer.

An example of MasterPacT MTZ product code

- MasterPacT type: MTZ2
- Rating: 1000 A
- Sensor rating: 800 A
- Performance level: H1
- MicroLogic: Active 5.0
- Number of poles: 4P
- Type of installation: Drawout with chassis
- Connection: Top horizontal bottom horizontal
- Type of communication: ULP + EIFE without I/O module
- Accessories for design and installation simplification and operation efficiency: No
- Accessories for people and property protection: No

> **Product code: WADFEADN**A**

When you want to share information with your colleagues or Schneider Electric CCC



Sending a text message through CCC app with the product code

When you want to know the selection of a circuit breaker



Checking the product code on the physical products

When you want to reorder a circuit breaker



Type in the product code through Product Selector and send order



Life Is On



Schneider Electric Industries SAS

35, rue Joseph Monier
CS 30323
92506 Rueil Malmaison Cedex
France

RCS Nanterre 954 503 439
Capital social 928 298 512 €
www.se.com

09/2025

© 2025 - Schneider Electric. All Rights Reserved.
All trademarks are owned by Schneider Electric Industries SAS or its affiliated companies.
Document reference: LVPED225010EN