

Soft Start Controllers



DS7 Soft Starter Controller



S611 Soft Starters



S811+ Soft Starters



1.1 Solid-State Controllers

Product Overview	V6-T1-2
DS7 Soft Start Controllers	V6-T1-3
Type S701 Soft Start Controllers	V6-T1-26
Type S701 Soft Start Controllers with Auxiliary Contact	V6-T1-32
Type S701 Soft Start Controllers with Brake	V6-T1-35
Type S511 Semiconductor Reversing Contactors	V6-T1-38

1.2 Solid-State Starters

Product Overview	V6-T1-42
Type S611 Soft Starters	V6-T1-43
Torque Limiters	V6-T1-59
S711 Soft Starters	V6-T1-61
Type S801+ Soft Starters	V6-T1-81
Type S811+ Soft Starters with DIM	V6-T1-97

Soft Start Controllers



Product Overview

DS7

Eaton’s DS7 line of reduced voltage solid-state soft start controllers is very compact, multi-functional, easy to install and easy to commission. Designed to control the acceleration and deceleration of three-phase motors with the ability to adjust initial torque, ramp up and down time, the device is available for current ranges from 4 to 32 A in four frame sizes.

Type S701

The S701 device is a reduced voltage soft start controller designed to control acceleration and deceleration of three-phase motors. The S701 provides the user with the ability to adjust initial torque, ramp up and down time, and also select kick start for high inertial loads.

Type S701 with Auxiliary Contact

The S701 device is a reduced voltage soft start controller designed to control acceleration and deceleration of three-phase motors. With the auxiliary contact, it is possible to control an external bypass to reduce heating and increase acceleration and deceleration times.

The unit provides the user with the ability to adjust initial torque, ramp up and down time and also select kick start for high inertia loads.

Contents

Description

Page

Soft Start Controllers	
DS7 Soft Start Controllers	V6-T1-3
Type S701 Soft Start Controllers	V6-T1-26
Type S701 Soft Start Controllers with Auxiliary Contact	V6-T1-32
Type S701 Soft Start Controllers with Brake	V6-T1-35
Type S511 Semiconductor Reversing Contactors	V6-T1-38

Type S701 with Brake

The S701 soft start controller with DC injection brake is designed to control acceleration and deceleration of three-phase motors. Brake current is adjustable from 0–50 A DC. The ramp-up feature is adjustable from 0.5–10 seconds. Torque adjustment is adjustable with or without break loose (kick start) function.

Type S511 Semiconductor Reversing Contactor

The S511 device is a semiconductor reversing contactor designed to switch three-phase motors forward and reverse. Unicore electronics and thermal design ensures high switching capacity and long lifetime.

DS7 Soft Start Controllers



Contents

<i>Description</i>	<i>Page</i>
DS7 Soft Start Controllers	
Features and Benefits	V6-T1-5
Standards and Certifications	V6-T1-5
Instructional Leaflets	V6-T1-5
Catalog Number Selection	V6-T1-6
Product Selection	V6-T1-7
Accessories	V6-T1-15
Technical Data and Specifications	V6-T1-16
Dimensions	V6-T1-24
Type S701 Soft Start Controllers	V6-T1-26
Type S701 Soft Start Controllers with Auxiliary Contact	V6-T1-32
Type S701 Soft Start Controllers with Brake	V6-T1-35
Type S511 Semiconductor Reversing Contactors	V6-T1-38

DS7 Soft Start Controllers

Product Description

The DS7 is available in standard and SmartWire-DT® communications configurations.

Standard (Non SmartWire-DT)

Eaton's DS7 line of reduced voltage solid-state soft start controllers is very compact, multi-functional, easy to install and easy to commission. Designed to control the acceleration and deceleration of three-phase motors, the device is available for current ranges from 4 to 200 FLA in four frame sizes. It is available with 24 Vdc, 24 Vdc/24 Vac, or 110/230 Vac control voltage options. A low temperature version is available with 24 Vac/Vdc control voltage with operation ambient temperature minimum of -40 °C.

SmartWire-DT

Our SmartWire-DT interface completely eliminates the need for conventional control wiring. This has several advantages:

- No incorrect wiring
- Faster wiring
- Cost saving

The interface can be used to send control commands to the DS7 SmartWire-DT and change and diagnose its parameter configuration; in addition, the control electronics can be powered via the SmartWire-DT cable. The device is controlled with one of the selectable profiles:

- A "start/stop" profile
- An 8 bit-wide profile for the soft starter, which is provided the same way for the variable frequency drive and features more options

Regardless of the profile chosen, the DS7 SmartWire-DT's parameters can be read and written to at any time by using acyclic communications services.

DS7 SmartWire-DT makes it possible to read and write to all device parameters. It is also possible to overwrite the potentiometer settings on the DS7 SmartWire-DT, which can come in handy, for instance, when a change made to the machine needs to be performed remotely.

The DS7 SmartWire-DT comes with a detailed diagnostic system with options that extend far beyond those of wired devices. In addition to having an error log, the DS7 SmartWire-DT can detect and report nine different device faults. A warning parameter reports any present warning messages. Moreover, the response to each individual fault can be customized. Finally, there are 35 additional messages for communication errors. Using the DS7 SmartWire-DT in connection with the PKE series motor protective circuit breakers opens up new functionalities that were previously thought impossible to implement with a low-cost soft starter and that were reserved to significantly more expensive devices. Combining a PKE unit and a DS7 SmartWire-DT makes it possible to completely protect the DS7 SmartWire-DT device against overloads. In addition, it provides a current limiting function and can report thermal capacity utilization levels to higher level controllers.

Application Description

With its small size, it can easily fit in place of existing soft starters, wye-delta starters, or across-the-line NEMA® and IEC starters. This feature allows easy upgrades to existing systems. The product is designed to be wired in the three-phase line feeding the three motor input leads as is done for normal across-the-line starting. The starter uses silicon controlled rectifiers (SCRs) to ramp the voltage to the motor, providing smooth acceleration and deceleration of the load. After the motor is started, the internal run bypass relay closes, resulting in the motor running directly across-the-line. Internal run bypass significantly reduces the heat generated as compared to non-bypass starters. The soft stop option allows for a ramp stop time that may be longer than the coast-to-stop time. An external overload protection relay or circuit breaker is needed.

Operation

Voltage Ramp Start

This start method provides a voltage ramp to the motor, resulting in a constant torque increase. This most commonly used form of soft start mode allows you to set the initial voltage value and the duration of the ramp to full voltage conditions.

- Adjustable initial voltage 30–92% of full voltage (120/230 Vac control voltage)
- Adjustable initial voltage 30–100% of full voltage (24 Vac/Vdc control voltage)
- Adjustable initial voltage 30–92% of full voltage (24 Vdc control voltage—SmartWire-DT)
- Adjustable ramp time 1–30 seconds
- Bypass relays close at the end the ramp time (TOR)

Soft Stop

Allows for a controlled stopping of load. Used when a stop-time that is greater than the coast-to-stop time is desired. Often used with high friction loads where a sudden stop may cause system or product damage. Setting the soft stop time to a value of 0 turns off this feature.

- Soft stop time = 0–30 seconds

Start Ramp

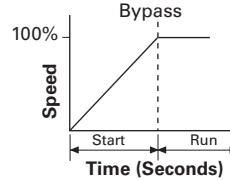

Stop Ramp

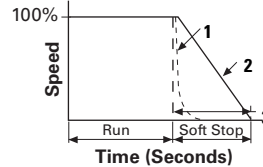

- 1 = Coast to Stop (Speed)
- 2 = Soft Stop Ramp (Voltage)
- 3 = Soft Stop Time

Auxiliary Contacts

Auxiliary contacts are provided to indicate soft start controller status.

Frame Size 1 (4 A to 12 A)—One Relay

The auxiliary relay indicates when the soft starter is at Top-of-Ramp (TOR).

Frame Size 2, 3 and 4 (16 A to 200 A)—Two Relays

One auxiliary relay indicates when the soft starter is at Top-of-Ramp (TOR).

One auxiliary relay indicates that a RUN command is present, including start ramp, bypass, and stop ramp times.

Features and Benefits

- Run bypass mode greatly reduces internal heating created by the power dissipation across the SCRs. The bypass relay directly connects the motor to the line and improves system efficiency by reducing internal power losses
- Less heat minimizes enclosure size and cooling requirements, and maximizes the life of all devices in the enclosure
- LED displays device status and provides fault indication
- Variable ramp times and voltage control (torque control) settings provide unlimited starting configurations, allowing for maximum application flexibility
- Soft stop control suits applications where an abrupt stop of the load is not acceptable. Soft acceleration and deceleration reduces wear on belts, gears, chains, clutches, shafts, and bearings
- Minimizes the peak inrush current's stress on the power system. Peak starting torque can be managed to diminish mechanical system wear and damage
- 24 Vac/Vdc control voltage enhances personnel and equipment safety. 110/230 Vac control voltage is also available
- Auxiliary relays indicate status of the soft start controllers
 - The TOR relay is active until motor stop command is received and/or the soft start controller detects a fault condition
 - RUN relay is active during the start ramp, bypass, and stop ramp

Protective Features

- Mains connection—The mains connection is monitored for a phase loss and/or undervoltage during ramp up
- Motor connection—The motor connection is monitored for an open condition during the ramp
- SCR faults—SCR performance is monitored during the ramp cycle for proper operation
- Heat sink over/under temperature—High ambient temperatures, extended ramp times, and high duty cycle conditions may cause the DS7 to exceed its thermal rating. When temperature goes under -5°C (-40°C for low temperature units), unit will trip as well. The DS7 is equipped with sensors that monitor the temperature of the device as well. The soft starter will trip in over/under temperature conditions, preventing device failure
- Warning is indicated for an over temperature condition for the next start
- Bypass relay
 - The DS7 can detect if the bypass relay fails to close after the ramp start or opens while the motor is running
 - The DS7 will also detect a condition whereas the bypass relay is closed when the RUN command is given
 - The DS7 will trip on a bypass dropout fault if either of these conditions occur

Standards and Certifications

- IEC 60947-4-2
- EN 60947-4-2
- UL® listed
- CSA certified
- CE marked
- C-Tick

**Instructional Leaflets**

- Instruction Leaflet IL03901001E

1.1

Reduced Voltage Motor Starters

Solid-State Controllers

1

Catalog Number Selection

DS7 Soft Start Controllers

DS7 - 3 4 0 SX 004 N 0 - N

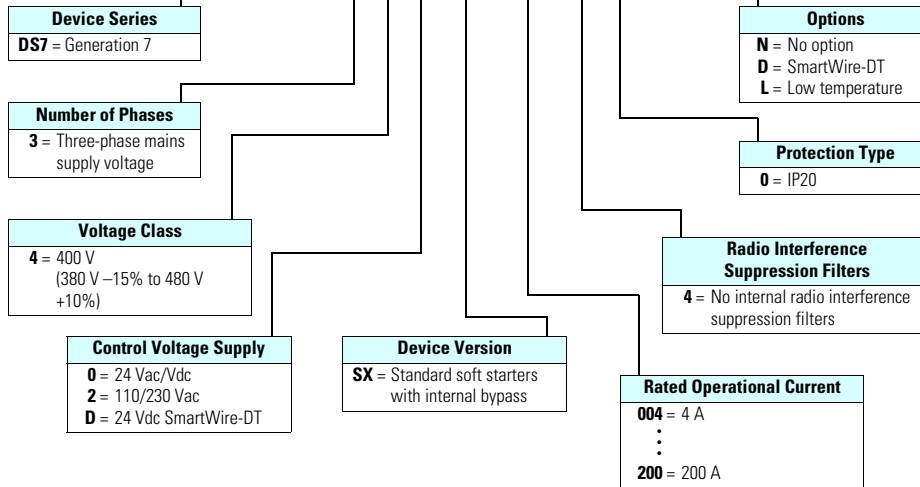

Product Selection

DS7 Soft Start Horsepower Ratings

Please refer to Application Note AP039004EN for additional information on proper size selection.

DS7 Soft Start Controller—
Frames 1 and 2



DS7 Soft Start Controllers—Horsepower Ratings— 10 Second Ramp, One Start per Hour, 300% Current Limit at 40 °C ①

Rated Current (A)	Motor Power (hp)			Maximum Allowable Breaker Size	Maximum Allowable Fuse Size	Recommended XTOB Overload (Direct Connect) ②	Recommended XTOE Overload ②		MMP ②	MMP ②	Connection Kit to MMP	Catalog Number
	200 V	230 V	480 V				PKE MMP	MMP ②				
3.7	0.75	0.75	2	HFD3015	15 A Class RK5	XTOB004BC1	XTOE005BCS	XTPE012BCS	XTPR004BC1	XTPAXTPCB		DS7-340SX004N0-N ④⑤
												DS7-342SX004N0-N ⑥
												DS7-34DSX004N0-D ⑦
6.9	1.5	2	3	HFD3015	15 A Class RK5	XTOB006BC1 ③	XTOE020BCS	XTPE012BCS	XTPR6P3BC1	XTPAXTPCB		DS7-340SX007N0-N ④⑤
												DS7-342SX007N0-N ⑥
												DS7-34DSX007N0-D ⑦
7.8	2	2	5	HFD3020	20 A Class RK5	XTOB010BC1	XTOE020BCS	XTPE012BCS	XTPR010BC1	XTPAXTPCB		DS7-340SX009N0-N ④⑤
												DS7-342SX009N0-N ⑥
												DS7-34DSX009N0-D ⑦
11	3	3	7.5	HFD3030	20 A Class RK5	XTOB012BC1	XTOE020BCS	XTPE032BCS	XTPR012BC1	XTPAXTPCB		DS7-340SX012N0-N ④⑤
												DS7-342SX012N0-N ⑥
												DS7-34DSX012N0-D ⑦
15.2	3	5	10	HFD3035	25 A Class RK5	XTOB016CC1	XTOE020CCS	XTPE032BCS	XTPR016BC1	XTPAXTPCC		DS7-340SX016N0-N ④⑤
												DS7-342SX016N0-N ⑥
												DS7-34DSX016N0-D ⑦
22	5	7.5	15	HFD3060	40 A Class RK5	XTOB024CC1	XTOE045CCS	XTPE032BCS	XTPR025BC1	XTPAXTPCC		DS7-340SX024N0-N ④⑤
												DS7-342SX024N0-N ⑥
												DS7-34DSX024N0-D ⑦
32	7.5	10	20	HFD3070	50 A Class RK5	XTOB032CC1	XTOE045CCS	XTPE032BCS	XTPR032BC1	XTPAXTPCC		DS7-340SX032N0-N ④⑤
												DS7-342SX032N0-N ⑥
												DS7-34DSX032N0-D ⑦

Notes

- ① Actual motor FLAs vary. Verify these devices cover the motor specific FLA.
- ② Selections are based on motor FLA value at 480 V.
- ③ Not to be used with 230 V.
- ④ 24 Vac/Vdc device.
- ⑤ -40 °C rated low temperature version available in 24 Vac/Vdc, change to "N0-L."
- ⑥ 110/230 Vac device.
- ⑦ 24 Vdc for SmartWire-DT device.

Considerations

1. Either XTOB, C306 or C440 series or equivalent overload protection devices may be selected.
2. Contactor is optional for normal applications. It is recommended for mains isolation.

Power Supply

Eaton's PSG and ELC power supplies are recommended as a compact and low-cost source for 24 Vdc power. The lightweight, DIN rail mounted devices have a wide input voltage range, and robust screw terminals make these power supplies easy to install and use. These power supplies are available in 1 A and 2 A models.

Power Supply Selection

Description	Catalog Number
85–264 V input and 24 Vdc output	ELC-PS01
100–240 V input and 24 Vdc output	PSG60E
400–500 V input and 24 Vdc output	PSG60F24RM

Please refer to Application Note AP039004EN for additional information on proper size selection.

DS7 Soft Start Controller—
Frames 3 and 4



DS7 Soft Start Controllers—Horsepower Ratings— 10 Second Ramp, One Start per Hour, 300% Current Limit at 40 °C

Rated Current (A)	Motor Power (hp)			Maximum Allowable Breaker Size ①	Maximum Allowable Fuse Size ①	Recommended XTOB Overload	Recommended C440 Overload	Catalog Number
	200 V	230 V	460 V					
40	10	10	30	HFD3150L	150 A Class RK5	XTOB040DC1 ②	C440A1A045SAX	DS7-340SX041N0-N ⑤⑥
								DS7-342SX041N0-N ⑦
								DS7-34DSX041N0-D ⑧
52	15	20	40	HFD3200L	200 A Class RK5	XTOB057DC1 ②	C440B1A100SAX	DS7-340SX055N0-N ⑤⑥
								DS7-342SX055N0-N ⑦
								DS7-34DSX055N0-D ⑧
65	20	25	50	HJD3250	200 A Class RK5	XTOB065DC1 ②	C440B1A100SAX	DS7-340SX070N0-N ⑤⑥
								DS7-342SX070N0-N ⑦
								DS7-34DSX070N0-D ⑧
77	25	30	60	HKD3300	300 A Class RK5	XTOB100GC1S	C440B1A100SAX	DS7-340SX081N0-N ⑤⑥
								DS7-342SX081N0-N ⑦
								DS7-34DSX081N0-D ⑧
96	30	30	75	HKD3350	350 A Class RK5	XTOB100GC1S	C440B1A100SAX	DS7-340SX100N0-N ⑤⑥
								DS7-342SX100N0-N ⑦
								DS7-34DSX100N0-D ⑧
124	40	50	100	HKD3400	500 A Class RK5	XTOB125GC1S	C440A1A005SAX ④	DS7-340SX135N0-N ⑤⑥
								DS7-342SX135N0-N ⑦
								DS7-34DSX135N0-D ⑧
156	50	60	125	HLD3450	500 A Class RK5	XTOB160LC1 ③	C440A1A005SAX ④	DS7-340SX160N0-N ⑤⑥
								DS7-342SX160N0-N ⑦
								DS7-34DSX160N0-D ⑧
180	60	75	150	HLD3500	500 A Class RK5	XTOB220LC1 ③	C440A1A005SAX ④	DS7-340SX200N0-N ⑤⑥
								DS7-342SX200N0-N ⑦
								DS7-34DSX200N0-D ⑧

Notes

- ① Maximum values may be higher than allowed per NEC® 430.52 and UL 508A 31.1.
- ② XTOBXDIND Panel Mounting Adapter must be used with this overload.
- ③ XTOBXTLL line and load lugs must be used with this overload.
- ④ ZEB-XCT300 current transformer must be used with this overload.
- ⑤ 24 Vac/Vdc device.
- ⑥ -40 °C rated low temperature version available in 24 Vac/Vdc, change to "N0-L."
- ⑦ 110/230 Vac device.
- ⑧ 24 Vdc for SmartWire-DT device.

Considerations

1. Either XTOB, C306 or C440 series or equivalent overload protection devices may be selected.
2. Contactor is optional for normal applications. It is recommended for mains isolation.

Power Supply

Eaton's PSG and ELC power supplies are recommended as a compact and low-cost source for 24 Vdc power. The lightweight, DIN rail mounted devices have a wide input voltage range, and robust screw terminals make these power supplies easy to install and use. These power supplies are available in 1 A and 2 A models.

Power Supply Selection

Description	Catalog Number
85–264 V input and 24 Vdc output	ELC-PS01
100–240 V input and 24 Vdc output	PSG60E
400–500 V input and 24 Vdc output	PSG60F24RM

Please refer to Application Note AP039004EN for additional information on proper size selection.

**DS7 Soft Start Controller—
Frames 1 and 2**



DS7 Soft Start Controllers—Horsepower Ratings— 10 Second Ramp, One Start per Hour, 400% Current Limit at 40 °C ①

Rated Current (A)	Motor Power (hp)			Maximum Allowable Breaker Size	Maximum Allowable Fuse Size	Recommended XTOB Overload (Direct Connect) ②	Recommended XTOE Overload ②	PKE MMP	MMP ②	Connection Kit to MMP	Catalog Number
	200 V	230 V	480 V								
3	0.5	0.5	1.5	HFD3015	15 A Class RK5	XTOB004BC1	XTOE005BCS	XTPE012BCS	XTPR004BC1	XTPAXTPCB	DS7-340SX004N0-N ④⑤
											DS7-342SX004N0-N ⑥
											DS7-34DSX004N0-D ⑦
4.8	1	1	3	HFD3015	15 A Class RK5	XTOB006BC1 ③	XTOE020BCS	XTPE012BCS	XTPR6P3BC1	XTPAXTPCB	DS7-340SX007N0-N ④⑤
											DS7-342SX007N0-N ⑥
											DS7-34DSX007N0-D ⑦
6.9	1.5	2	3	HFD3020	20 A Class RK5	XTOB006BC1	XTOE020BCS	XTPE012BCS	XTPR6P3BC1	XTPAXTPCB	DS7-340SX009N0-N ④⑤
											DS7-342SX009N0-N ⑥
											DS7-34DSX009N0-D ⑦
9	2	2	5	HFD3030	20 A Class RK5	XTOB010BC1	XTOE020BCS	XTPE032BCS	XTPR010BC1	XTPAXTPCB	DS7-340SX012N0-N ④⑤
											DS7-342SX012N0-N ⑥
											DS7-34DSX012N0-D ⑦
11	3	3	7.5	HFD3035	25 A Class RK5	XTOB016CC1	XTOE020CCS	XTPE032BCS	XTPR016BC1	XTPAXTPCC	DS7-340SX016N0-N ④⑤
											DS7-342SX016N0-N ⑥
											DS7-34DSX016N0-D ⑦
17.5	5	5	10	HFD3060	40 A Class RK5	XTOB016CC1	XTOE045CCS	XTPE032BCS	XTPR016BC1	XTPAXTPCC	DS7-340SX024N0-N ④⑤
											DS7-342SX024N0-N ⑥
											DS7-34DSX024N0-D ⑦
22	5	7.5	15	HFD3070	50 A Class RK5	XTOB024CC1	XTOE045CCS	XTPE032BCS	XTPR025BC1	XTPAXTPCC	DS7-340SX032N0-N ④⑤
											DS7-342SX032N0-N ⑥
											DS7-34DSX032N0-D ⑦

Notes

- ① Actual motor FLAs vary. Verify these devices cover the motor specific FLA.
- ② Selections are based on motor FLA value at 480 V.
- ③ Not to be used with 230 V.
- ④ 24 Vac/Vdc device.
- ⑤ -40 °C rated low temperature version available in 24 Vac/Vdc, change to "N0-L."
- ⑥ 110/230 Vac device.
- ⑦ 24 Vdc for SmartWire-DT device.

Considerations

1. Either XTOB, C306 or C440 series or equivalent overload protection devices may be selected.
2. Contactor is optional for normal applications. It is recommended for mains isolation.

Power Supply

Eaton's PSG and ELC power supplies are recommended as a compact and low-cost source for 24 Vdc power. The lightweight, DIN rail mounted devices have a wide input voltage range, and robust screw terminals make these power supplies easy to install and use. These power supplies are available in 1 A and 2 A models.

Power Supply Selection

Description	Catalog Number
85–264 V input and 24 Vdc output	ELC-PS01
100–240 V input and 24 Vdc output	PSG60E
400–500 V input and 24 Vdc output	PSG60F24RM

Please refer to Application Note AP039004EN for additional information on proper size selection.

DS7 Soft Start Controller—
Frames 3 and 4



DS7 Soft Start Controllers—Horsepower Ratings— 10 Second Ramp, One Start per Hour, 400% Current Limit at 40 °C

Rated Current (A)	Motor Power (hp)			Maximum Allowable Breaker Size ①	Maximum Allowable Fuse Size ①	Recommended XTOB Overload	Recommended C440 Overload	Catalog Number
	200 V	230 V	460 V					
27	7.5	10	20	HFD3150L	150 A Class RK5	XTOB040DC1	C440A1A045SAX	DS7-340SX041N0-N ④⑤
								DS7-342SX041N0-N ⑥
								DS7-34DSX041N0-D ⑦
34	10	10	30	HFD3200L	200 A Class RK5	XTOB040DC1	C440A1A045SAX	DS7-340SX055N0-N ④⑤
								DS7-342SX055N0-N ⑥
								DS7-34DSX055N0-D ⑦
40	15	15	30	HJD3250	200 A Class RK5	XTOB057DC1 ②	C440A1A045SAX	DS7-340SX070N0-N ④⑤
								DS7-342SX070N0-N ⑥
								DS7-34DSX070N0-D ⑦
52	15	20	40	HKD3300	300 A Class RK5	XTOB057DC1 ②	C440B1A100SAX	DS7-340SX081N0-N ④⑤
								DS7-342SX081N0-N ⑥
								DS7-34DSX081N0-D ⑦
65	20	25	50	HKD3350	350 A Class RK5	XTOB100GC1S	C440B1A100SAX	DS7-340SX100N0-N ④⑤
								DS7-342SX100N0-N ⑥
								DS7-34DSX100N0-D ⑦
80	30	30	75	HKD3350	500 A Class RK5	XTOB100GC1S	C440B1A100SAX	DS7-340SX135N0-N ④⑤
								DS7-342SX135N0-N ⑥
								DS7-34DSX135N0-D ⑦
96	30	40	75	HLD3450	500 A Class RK5	XTOB100GC1S	C440B1A100SAX	DS7-340SX160N0-N ④⑤
								DS7-342SX160N0-N ⑥
								DS7-34DSX160N0-D ⑦
124	40	50	100	HLD3500	500 A Class RK5	XTOB150GC1S	C440A1A005SAX ③	DS7-340SX200N0-N ④⑤
								DS7-342SX200N0-N ⑥
								DS7-34DSX200N0-D ⑦

Notes

- ① Maximum values may be higher than allowed per NEC 430.52 and UL 508A 31.1.
- ② XTOBXDIND Panel Mounting Adapter must be used with this overload.
- ③ ZEB-XCT300 current transformer must be used with this overload.
- ④ 24 Vac/Vdc device.
- ⑤ -40 °C rated low temperature version available in 24 Vac/Vdc, change to "NO-L."
- ⑥ 110/230 Vac device.
- ⑦ 24 Vdc for SmartWire-DT device.

Considerations

1. Either XTOB, C306 or C440 series or equivalent overload protection devices may be selected.
2. Contactor is optional for normal applications. It is recommended for mains isolation.

Power Supply

Eaton's PSG and ELC power supplies are recommended as a compact and low-cost source for 24 Vdc power. The lightweight, DIN rail mounted devices have a wide input voltage range, and robust screw terminals make these power supplies easy to install and use. These power supplies are available in 1 A and 2 A models.

Power Supply Selection

Description	Catalog Number
85–264 V input and 24 Vdc output	ELC-PS01
100–240 V input and 24 Vdc output	PSG60E
400–500 V input and 24 Vdc output	PSG60F24RM

DS7 Soft Start kW Ratings

Please refer to Application Note AP039004EN for additional information on proper size selection.

DS7 Soft Start Controller—
Frames 1 and 2



DS7 Soft Start Controllers—kW Ratings According to IEC 60947-4-2— 10 Second Ramp, One Start per Hour, 300% Current Limit at 40 °C ①

Rated Current (A)	Motor Power (kW)		Maximum Allowable Breaker Size	Maximum Allowable Fuse Size	Recommended XTOB Overload (Direct Connect) ②	Recommended XTOE Overload ②	PKE MMP	MMP ②	Connection Kit to MMP	Catalog Number
	230 V	400 V								
3.8	0.75	1.5	HFD3015	15 A Class RK5	XTOB004BC1	XTOE005BCS	XTPE012BCS	XTPR004BC1	XTPAXTPCB	DS7-340SX004N0-N ④⑤
										DS7-342SX004N0-N ⑥
										DS7-34DSX004N0-D ⑦
7	1.5	3	HFD3015	15 A Class RK5	XTOB006BC1 ③	XTOE020BCS	XTPE012BCS	XTPR06P3BC1	XTPAXTPCB	DS7-340SX007N0-N ④⑤
										DS7-342SX007N0-N ⑥
										DS7-34DSX007N0-D ⑦
9	2.2	4	HFD3020	20 A Class RK5	XTOB010BC1	XTOE020BCS	XTPE012BCS	XTPR010BC1	XTPAXTPCB	DS7-340SX009N0-N ④⑤
										DS7-342SX009N0-N ⑥
										DS7-34DSX009N0-D ⑦
12	3	5.5	HFD3030	20 A Class RK5	XTOB012BC1	XTOE020BCS	XTPE032BCS	XTPR012BC1	XTPAXTPCB	DS7-340SX012N0-N ④⑤
										DS7-342SX012N0-N ⑥
										DS7-34DSX012N0-D ⑦
16	4	7.5	HFD3035	25 A Class RK5	XTOB016CC1	XTOE020CCS	XTPE032BCS	XTPR016BC1	XTPAXTPCC	DS7-340SX016N0-N ④⑤
										DS7-342SX016N0-N ⑥
										DS7-34DSX016N0-D ⑦
24	5.5	11	HFD3060	40 A Class RK5	XTOB024CC1	XTOE045CCS	XTPE032BCS	XTPR025BC1	XTPAXTPCC	DS7-340SX024N0-N ④⑤
										DS7-342SX024N0-N ⑥
										DS7-34DSX024N0-D ⑦
32	7.5	15	HFD3070	50 A Class RK5	XTOB032CC1	XTOE045CCS	XTPE032BCS	XTPR032BC1	XTPAXTPCC	DS7-340SX032N0-N ④⑤
										DS7-342SX032N0-N ⑥
										DS7-34DSX032N0-D ⑦

Notes

- ① Actual motor FLAs vary. Verify these devices cover the motor specific FLA.
- ② Selections are based on motor FLA value at 480 V.
- ③ Not to be used with 230 V.
- ④ 24 Vac/Vdc device.
- ⑤ -40 °C rated low temperature version available in 24 Vac/Vdc, change to "N0-L."
- ⑥ 110/230 Vac device.
- ⑦ 24 Vdc for SmartWire-DT device.

Considerations

1. Either XTOB, C306 or C440 series or equivalent overload protection devices may be selected.
2. Contactor is optional for normal applications. It is recommended for mains isolation.

Power Supply

Eaton's PSG and ELC power supplies are recommended as a compact and low-cost source for 24 Vdc power. The lightweight, DIN rail mounted devices have a wide input voltage range, and robust screw terminals make these power supplies easy to install and use. These power supplies are available in 1 A and 2 A models.

Power Supply Selection

Description	Catalog Number
85–264 V input and 24 Vdc output	ELC-PS01
100–240 V input and 24 Vdc output	PSG60E
400–500 V input and 24 Vdc output	PSG60F24RM

Please refer to Application Note AP039004EN for additional information on proper size selection.

DS7 Soft Start Controller—
Frames 3 and 4



DS7 Soft Start Controllers—kW Ratings According to IEC 60947-4-2— 10 Second Ramp, One Start per Hour, 300% Current Limit at 40 °C

Rated Current (A)	Motor Power (kW)		Maximum Allowable Breaker Size ^①	Maximum Allowable Fuse Size ^①	Recommended XTOB Overload	Recommended C440 Overload	Catalog Number
	230 V	400 V					
41	11	22	HFD3150L	150 A Class RK5	XTOB057DC1 ^②	C440A1A045SAX	DS7-340SX041N0-N ^{⑤⑥}
							DS7-342SX041N0-N ^⑦
							DS7-34DSX041N0-D ^⑧
55	15	30	HFD3200L	200 A Class RK5	XTOB057DC1 ^②	C440B1A100SAX	DS7-340SX055N0-N ^{⑤⑥}
							DS7-342SX055N0-N ^⑦
							DS7-34DSX055N0-D ^⑧
68	15	37	HJD3250	200 A Class RK5	XTOB070GC1 ^②	C440B1A100SAX	DS7-340SX070N0-N ^{⑤⑥}
							DS7-342SX070N0-N ^⑦
							DS7-34DSX070N0-D ^⑧
81	22	45	HKD3300	300 A Class RK5	XTOB100GC1S	C440B1A100SAX	DS7-340SX081N0-N ^{⑤⑥}
							DS7-342SX081N0-N ^⑦
							DS7-34DSX081N0-D ^⑧
99	30	55	HKD3350	350 A Class RK5	XTOB100GC1S	C440B1A100SAX	DS7-340SX100N0-N ^{⑤⑥}
							DS7-342SX100N0-N ^⑦
							DS7-34DSX041N0-D ^⑧
134	30	75	HKD3400	500 A Class RK5	XTOB150GC1S	C440A1A005SAX ^④	DS7-340SX135N0-N ^{⑤⑥}
							DS7-342SX135N0-N ^⑦
							DS7-34DSX135N0-D ^⑧
160	45	90	HLD3450	500 A Class RK5	XTOB160LC1 ^③	C440A1A005SAX ^④	DS7-340SX160N0-N ^{⑤⑥}
							DS7-342SX160N0-N ^⑦
							DS7-34DSX160N0-D ^⑧
196	55	110	HLD3500	500 A Class RK5	XTOB220LC1 ^③	C440A1A005SAX ^④	DS7-340SX200N0-N ^{⑤⑥}
							DS7-342SX200N0-N ^⑦
							DS7-34DSX200N0-D ^⑧

Notes

- ① Maximum values may be higher than allowed per NEC 430.52 and UL 508A 31.1.
- ② XTOBXDIND Panel Mounting Adapter must be used with this overload.
- ③ XTOBXTLL line and load lugs must be used with this overload.
- ④ ZEB-XCT300 current transformer must be used with this overload.
- ⑤ 24 Vac/Vdc device.
- ⑥ -40 °C rated low temperature version available in 24 Vac/Vdc, change to "N0-L."
- ⑦ 110/230 Vac device.
- ⑧ 24 Vdc for SmartWire-DT device.

Considerations

1. Either XTOB, C306 or C440 series or equivalent overload protection devices may be selected.
2. Contactor is optional for normal applications. It is recommended for mains isolation.

Power Supply

Eaton's PSG and ELC power supplies are recommended as a compact and low-cost source for 24 Vdc power. The lightweight, DIN rail mounted devices have a wide input voltage range, and robust screw terminals make these power supplies easy to install and use. These power supplies are available in 1 A and 2 A models.

Power Supply Selection

Description	Catalog Number
85–264 V input and 24 Vdc output	ELC-PS01
100–240 V input and 24 Vdc output	PSG60E
400–500 V input and 24 Vdc output	PSG60F24RM

Please refer to Application Note AP039004EN for additional information on proper size selection.

**DS7 Soft Start Controller—
Frames 1 and 2**



DS7 Soft Start Controllers—kW Ratings According to IEC 60947-4-2— 10 Second Ramp, One Start per Hour, 400% Current Limit at 40 °C ^①

Rated Current (A)	Motor Power (kW)		Maximum Allowable Breaker Size	Maximum Allowable Fuse Size	Recommended XTOB Overload (Direct Connect) ^②	Recommended XTOE Overload ^②	PKE MMP	MMP ^②	Connection Kit to MMP	Catalog Number
	230 V	400 V								
2.5	0.33	1	HFD3015	15 A Class RK5	XTOB004BC1	XTOE005BCS	XTPE012BCS	XTPR004BC1	XTPAXTPCB	DS7-340SX004N0-N ^{④⑤}
										DS7-342SX004N0-N ^⑥
										DS7-34DSX004N0-D ^⑦
3.8	0.75	1.5	HFD3015	15 A Class RK5	XTOB006BC1 ^③	XTOE020BCS	XTPE012BCS	XTPR6P3BC1	XTPAXTPCB	DS7-340SX007N0-N ^{④⑤}
										DS7-342SX007N0-N ^⑥
										DS7-34DSX007N0-D ^⑦
7	1.5	3	HFD3020	20 A Class RK5	XTOB006BC1	XTOE020BCS	XTPE012BCS	XTPR6P3BC1	XTPAXTPCB	DS7-340SX009N0-N ^{④⑤}
										DS7-342SX009N0-N ^⑥
										DS7-34DSX009N0-D ^⑦
9	2.2	4	HFD3030	20 A Class RK5	XTOB010BC1	XTOE020BCS	XTPE032BCS	XTPR010BC1	XTPAXTPCB	DS7-340SX012N0-N ^{④⑤}
										DS7-342SX012N0-N ^⑥
										DS7-34DSX012N0-D ^⑦
12	3	5.5	HFD3035	25 A Class RK5	XTOB016CC1	XTOE020CCS	XTPE032BCS	XTPR016BC1	XTPAXTPCC	DS7-340SX016N0-N ^{④⑤}
										DS7-342SX016N0-N ^⑥
										DS7-34DSX016N0-D ^⑦
16	4	7.5	HFD3060	40 A Class RK5	XTOB016CC1	XTOE045CCS	XTPE032BCS	XTPR016BC1	XTPAXTPCC	DS7-340SX024N0-N ^{④⑤}
										DS7-342SX024N0-N ^⑥
										DS7-34DSX016N0-D ^⑦
24	5.5	11	HFD3070	50 A Class RK5	XTOB024CC1	XTOE045CCS	XTPE032BCS	XTPR025BC1	XTPAXTPCC	DS7-340SX032N0-N ^{④⑤}
										DS7-342SX032N0-N ^⑥
										DS7-34DSX032N0-D ^⑦

Notes

- ① Actual motor FLAs vary. Verify these devices cover the motor specific FLA.
- ② Selections are based on motor FLA value at 480 V.
- ③ Not to be used with 230 V.
- ④ 24 Vac/Vdc device.
- ⑤ -40 °C rated low temperature version available in 24 Vac/Vdc, change to "N0-L."
- ⑥ 110/230 Vac device.
- ⑦ 24 Vdc for SmartWire-DT device.

Considerations

1. Either XTOB, C306 or C440 series or equivalent overload protection devices may be selected.
2. Contactor is optional for normal applications. It is recommended for mains isolation.

Power Supply

Eaton's PSG and ELC power supplies are recommended as a compact and low-cost source for 24 Vdc power. The lightweight, DIN rail mounted devices have a wide input voltage range, and robust screw terminals make these power supplies easy to install and use. These power supplies are available in 1 A and 2 A models.

Power Supply Selection

Description	Catalog Number
85–264 V input and 24 Vdc output	ELC-PS01
100–240 V input and 24 Vdc output	PSG60E
400–500 V input and 24 Vdc output	PSG60F24RM

Please refer to Application Note AP039004EN for additional information on proper size selection.

DS7 Soft Start Controller—
Frames 3 and 4



**DS7 Soft Start Controllers—kW Ratings According to IEC 60947-4-2—
10 Second Ramp, One Start per Hour, 400% Current Limit at 40 °C**

Rated Current (A)	Motor Power (kW)		Maximum Allowable Breaker Size ①	Maximum Allowable Fuse Size ①	Recommended XTOB Overload	Recommended C440 Overload	Catalog Number
	230 V	400 V					
28.8	7.5	11	HFD3150L	150 A Class RK5	XTOB040DC1	C440A1A045SAX	DS7-340SX041N0-N ⑤⑥
							DS7-342SX041N0-N ⑦
							DS7-34DSX041N0-D ⑧
37.5	11	18.5	HFD3200L	200 A Class RK5	XTOB040DC1	C440A1A045SAX	DS7-340SX055N0-N ⑤⑥
							DS7-342SX055N0-N ⑦
							DS7-34DSX055N0-D ⑧
46	11	22	HJD3250	200 A Class RK5	XTOB057DC1 ②	C440B1A100SAX	DS7-340SX070N0-N ⑤⑥
							DS7-342SX070N0-N ⑦
							DS7-34DSX070N0-D ⑧
56	15	30	HKD3300	300 A Class RK5	XTOB065DC1 ②	C440B1A100SAX	DS7-340SX081N0-N ⑤⑥
							DS7-342SX081N0-N ⑦
							DS7-34DSX081N0-D ⑧
68	18.5	37	HKD3350	350 A Class RK5	XTOB100GC1S	C440B1A100SAX	DS7-340SX100N0-N ⑤⑥
							DS7-342SX100N0-N ⑦
							DS7-34DSX100N0-D ⑧
90	22	45	HKD3350	500 A Class RK5	XTOB100GC1S	C440B1A100SAX	DS7-340SX135N0-N ⑤⑥
							DS7-342SX135N0-N ⑦
							DS7-34DSX135N0-D ⑧
106	30	55	HLD3450	500 A Class RK5	XTOB160LC1 ③	C440A1A005SAX ④	DS7-340SX160N0-N ⑤⑥
							DS7-342SX160N0-N ⑦
							DS7-34DSX160N0-D ⑧
134	37	75	HLD3500	500 A Class RK5	XTOB160LC1 ③	C440A1A005SAX ④	DS7-340SX200N0-N ⑤⑥
							DS7-342SX200N0-N ⑦
							DS7-34DSX200N0-D ⑧

Notes

- ① Maximum values may be higher than allowed per NEC 430.52 and UL 508A 31.1.
- ② XTOBXDIND Panel Mounting Adapter must be used with this overload.
- ③ XTOBXTLL line and load lugs must be used with this overload.
- ④ ZEB-XCT300 current transformer must be used with this overload.
- ⑤ 24 Vac/Vdc device.
- ⑥ -40 °C rated low temperature version available in 24 Vac/Vdc, change to "N0-L."
- ⑦ 110/230 Vac device.
- ⑧ 24 Vdc for SmartWire-DT device.

Considerations

1. Either XTOB, C306 or C440 series or equivalent overload protection devices may be selected.
2. Contactor is optional for normal applications. It is recommended for mains isolation.

Power Supply

Eaton's PSG and ELC power supplies are recommended as a compact and low-cost source for 24 Vdc power. The lightweight, DIN rail mounted devices have a wide input voltage range, and robust screw terminals make these power supplies easy to install and use. These power supplies are available in 1 A and 2 A models.

Power Supply Selection

Description	Catalog Number
85–264 V input and 24 Vdc output	ELC-PS01
100–240 V input and 24 Vdc output	PSG60E
400–500 V input and 24 Vdc output	PSG60F24RM

Accessories

Device Fans

DS7-FAN-032



Description	For Use With ...	Std. Pack	Catalog Number
Device fan for increasing the load cycle (more starts per hour higher or longer ramp times exceeding 10 seconds.	DS7-34...SX004...	1 off	DS7-FAN-032 ①
	DS7-34...SX007...		
	DS7-34...SX009...		
	DS7-34...SX012...		
	DS7-34...SX016...		
	DS7-34...SX024...		
	DS7-34...SX032...		

Note

① NA Certification. Request filed for UL and CSA.

Technical Data and Specifications

DS7 Soft Start Controllers

Rated Control Circuit

Voltage 24 Vac/Vdc
Voltage 110/230 Vac
Voltage 24 Vdc

Unit	DS7-340SX004N0-N DS7-342SX004N0-N DS7-34DSX004N0-D	DS7-340SX007N0-N DS7-342SX007N0-N DS7-34DSX007N0-D	DS7-340SX009N0-N DS7-342SX009N0-N DS7-34DSX009N0-D	DS7-340SX012N0-N DS7-342SX012N0-N DS7-34DSX012N0-D
------	--	--	--	--

General

Standards		IEC/EN 60947-4-2; GB14048.6; UL508; CSA-C22.2 No 0-M91; CSA-C22.2 No 14-05 CE marking	IEC/EN 60947-4-2; GB14048.6; UL508; CSA-C22.2 No 0-M91; CSA-C22.2 No 14-05 CE marking	IEC/EN 60947-4-2; GB14048.6; UL508; CSA-C22.2 No 0-M91; CSA-C22.2 No 14-05 CE marking	IEC/EN 60947-4-2; GB14048.6; UL508; CSA-C22.2 No 0-M91; CSA-C22.2 No 14-05 CE marking
Certifications/markings		UL/CE/CSA/C-Tick	UL/CE/CSA/C-Tick	UL/CE/CSA/C-Tick	UL/CE/CSA/C-Tick
Ambient temperature (operation)	°C	0 to 40 °C, above 40 °C de-rate linearly by 1% of rated current per Celsius to 60 °C –40 to +40 °C for low temperature version	0 to 40 °C, above 40 °C de-rate linearly by 1% of rated current per Celsius to 60 °C –40 to +40 °C for low temperature version	0 to 40 °C, above 40 °C de-rate linearly by 1% of rated current per Celsius to 60 °C –40 to +40 °C for low temperature version	0 to 40 °C, above 40 °C de-rate linearly by 1% of rated current per Celsius to 60 °C –40 to +40 °C for low temperature version
Ambient temperature (storage)	°C	–25 to 55 °C	–25 to 55 °C	–25 to 55 °C	–25 to 55 °C
Altitude		0–1000 m, above 1000 m de-rate linearly by 2.5% of rated current per 100 m to a maximum of 2000 m	0–1000 m, above 1000 m de-rate linearly by 2.5% of rated current per 100 m to a maximum of 2000 m	0–1000 m, above 1000 m de-rate linearly by 2.5% of rated current per 100 m to a maximum of 2000 m	0–1000 m, above 1000 m de-rate linearly by 2.5% of rated current per 100 m to a maximum of 2000 m
Installation		Vertical	Vertical	Vertical	Vertical
Protection class		IP20	IP20	IP20	IP20
Protection class applies to the front and operator control and display elements. Protection type from all sides is IP00.		With optional covers from the NZM range, protection type IP40 from all sides can be achieved	With optional covers from the NZM range, protection type IP40 from all sides can be achieved	With optional covers from the NZM range, protection type IP40 from all sides can be achieved	With optional covers from the NZM range, protection type IP40 from all sides can be achieved
Busbar tag shroud		Back of hand and finger-proof (from front face)	Back of hand and finger-proof (from front face)	Back of hand and finger-proof (from front face)	Back of hand and finger-proof (from front face)
Overvoltage category/pollution degree		II/2	II/2	II/2	II/2
Shock resistance		8 g/11 ms	8 g/11 ms	8 g/11 ms	8 g/11 ms
Vibration resistance according to EN 60721-3-2		2M2	2M2	2M2	2M2
Mean heat dissipation at rated duty cycle	W	0.2	0.35	0.35	0.6
Radio interference		B	B	B	B
Dimensions (W x H x D)					
DS7-340... and DS7-342...	in (mm)	1.77 x 5.12 x 3.74 (45 x 130 x 95)	1.77 x 5.12 x 3.74 (45 x 130 x 95)	1.77 x 5.12 x 3.74 (45 x 130 x 95)	1.77 x 5.12 x 3.74 (45 x 130 x 95)
DS7-34D...	in (mm)	1.77 x 5.31 x 3.74 (45 x 135 x 95)	1.77 x 5.31 x 3.74 (45 x 135 x 95)	1.77 x 5.31 x 3.74 (45 x 135 x 95)	1.77 x 5.31 x 3.74 (45 x 135 x 95)
Weight					
DS7-340...	lb (kg)	0.77 (0.35)	0.77 (0.35)	0.77 (0.35)	0.77 (0.35)
DS7-342...	lb (kg)	0.88 (0.40)	0.88 (0.40)	0.88 (0.40)	0.88 (0.40)
DS7-34D...	lb (kg)	0.90 (0.41)	0.90 (0.41)	0.90 (0.41)	0.90 (0.41)
Main Circuit					
Rated operational voltage	V	230–460 Vac	230–460 Vac	230–460 Vac	230–460 Vac
Mains frequency	Hz	50/60 Hz	50/60 Hz	50/60 Hz	50/60 Hz
Rated operation current AC 53	I _e	4	7	9	12
Motor Power Ratings					
200 V	hp	0.75	1.5	2	3
230 V	hp	0.75	2	2	5
480 V	hp	2	3	5	10
230 V	kW	0.75	1.5	2.2	3
400 V	kW	1.5	3	4	5.5
Overload cycle according to EN 60947-4-2		4A: AC53a; 3-5; 75-10	7A: AC53a; 3-5; 75-10	9A: AC53a; 3-5; 75-10	12A: AC53a; 3-5; 75-10

DS7 Soft Start Controllers, continued

Rated Control Circuit			DS7-340SX004N0-N	DS7-340SX007N0-N	DS7-340SX009N0-N	DS7-340SX012N0-N
Voltage 24 Vac/Vdc		Unit	DS7-342SX004N0-N	DS7-342SX007N0-N	DS7-342SX009N0-N	DS7-342SX012N0-N
Voltage 110/230 Vac			DS7-34DSX004N0-D	DS7-34DSX007N0-D	DS7-34DSX009N0-D	DS7-34DSX012N0-D
Voltage 24 Vdc						
Wire Specifications						
Power terminals						
Single conductor—solid or stranded	AWG		18–10	18–10	18–10	18–10
Terminal torque	lb-in		11	11	11	11
Control signals						
Single conductor—solid or stranded	AWG		18–10	18–10	18–10	18–10
Terminal torque	lb-in		11	11	11	11
Power Section						
Rated impulse withstand voltage	U_{imp} 1.2/ 50 s		4 kV	4 kV	4 kV	4 kV
Rated insulation voltage			500	500	500	500
Control Commands – Vac/Vdc						
Supply voltage control board U_s nominal	Vac/Vdc		20.4–26.4	20.4–26.4	20.4–26.4	20.4–26.4
Current consumption at 24 Vac/Vdc	mA		1.6	1.6	1.6	1.6
Pick-up voltage			+17.3–+27	+17.3–+27	+17.3–+27	+17.3–+27
Drop-out voltage			+3–0	+3–0	+3–0	+3–0
Relay Outputs						
Number of relays			1 (TOR)	1 (TOR)	1 (TOR)	1 (TOR)
Maximum voltage	Vac		250	250	250	250
Maximum current	A		1A	1A	1A	1A
Soft Start Functions						
Ramp times						
Start ramp	s		1–30	1–30	1–30	1–30
Stop ramp	s		0–30	0–30	0–30	0–30
Initial voltage % line voltage						
DS7-342...			30–92%	30–92%	30–92%	30–92%
DS7-340...			30–100%	30–100%	30–100%	30–100%
DS7-34D...			30–92%	30–92%	30–92%	30–92%
Control Commands – Vac						
Supply voltage control board U_s nominal	Vac		102–253	102–253	102–253	102–253
Current consumption at 24 Vac/Vdc	mA		4	4	4	4
Pick-up voltage	Vac		102–230	102–230	102–230	102–230
Drop-out voltage	Vac		0–28	0–28	0–28	0–28
Relay Outputs						
Number of relays			1 (TOR)	1 (TOR)	1 (TOR)	1 (TOR)
Maximum voltage	Vac		250	250	250	250
Maximum current	A		3	3	3	3
Soft Start Functions						
Ramp times						
Start ramp	s		1–30	1–30	1–30	1–30
Stop ramp	s		0–30	0–30	0–30	0–30
Initial voltage % line voltage			30–92%	30–92%	30–92%	30–92%

DS7 Soft Start Controllers, continued

Rated Control Circuit

Voltage 24 Vac/Vdc
Voltage 110/230 Vac
Voltage 24 Vdc

Unit

DS7-340SX016N0-N
DS7-342SX016N0-N
DS7-34DSX016N0-D

DS7-340SX024N0-N
DS7-342SX024N0-N
DS7-34DSX024N0-D

DS7-340SX032N0-N
DS7-342SX032N0-N
DS7-34DSX032N0-D

General

Standards		IEC/EN 60947-4-2; GB14048.6; UL508; CSA-C22.2 No 0-M91; CSA-C22.2 No 14-05 CE marking	IEC/EN 60947-4-2; GB14048.6; UL508; CSA-C22.2 No 0-M91; CSA-C22.2 No 14-05 CE marking	IEC/EN 60947-4-2; GB14048.6; UL508; CSA-C22.2 No 0-M91; CSA-C22.2 No 14-05 CE marking
Certifications/markings		UL/CE/CSA/C-Tick	UL/CE/CSA/C-Tick	UL/CE/CSA/C-Tick
Ambient temperature (operation)	°C	0 to 40 °C, above 40 °C de-rate linearly by 1% of rated current per Celsius to 60 °C –40 to +40 °C for low temperature version	0 to 40 °C, above 40 °C de-rate linearly by 1% of rated current per Celsius to 60 °C –40 to +40 °C for low temperature version	0 to 40 °C, above 40 °C de-rate linearly by 1% of rated current per Celsius to 60 °C –40 to +40 °C for low temperature version
Ambient temperature (storage)	°C	–25 to 55 °C	–25 to 55 °C	–25 to 55 °C
Altitude		0–1000 m, above 1000 m de-rate linearly by 2.5% of rated current per 100m to a maximum of 2000 m	0–1000 m, above 1000 m de-rate linearly by 2.5% of rated current per 100m to a maximum of 2000 m	0–1000 m, above 1000 m de-rate linearly by 2.5% of rated current per 100m to a maximum of 2000 m
Installation		Vertical	Vertical	Vertical
Protection class		IP20	IP20	IP20
Protection class applies to the front and operator control and display elements. Protection type from all sides is IP00.		With optional covers from the NZM range, protection type IP40 from all sides can be achieved	With optional covers from the NZM range, protection type IP40 from all sides can be achieved	With optional covers from the NZM range, protection type IP40 from all sides can be achieved
Busbar tag shroud		Back of hand and finger-proof (from front face)	Back of hand and finger-proof (from front face)	Back of hand and finger-proof (from front face)
Overvoltage category/ pollution degree		II/2	II/2	II/2
Shock resistance		8 g/11 ms	8 g/11 ms	8 g/11 ms
Vibration resistance according to EN 60721-3-2		2M2	2M2	2M2
Mean heat dissipation at rated duty cycle	W	0.8	1.1	1.5
Radio interference		B	B	B
Dimensions (W x H x D)				
DS7-340... and DS7-342...	in (mm)	1.77 x 5.91 x 4.65 (45 x 150 x 118)	1.77 x 5.91 x 4.65 (45 x 150 x 118)	1.77 x 5.91 x 4.65 (45 x 150 x 118)
DS7-34D...	in (mm)	1.77 x 5.91 x 4.65 (45 x 150 x 118)	1.77 x 5.91 x 4.65 (45 x 150 x 118)	1.77 x 5.91 x 4.65 (45 x 150 x 118)
Weight				
DS7-340...	lb (kg)	0.88 (0.40)	0.88 (0.40)	0.88 (0.40)
DS7-342...	lb (kg)	0.99 (0.45)	0.99 (0.45)	0.99 (0.45)
DS7-34D...	lb (kg)	0.90 (0.41)	0.90 (0.41)	0.90 (0.41)
Main Circuit				
Rated operational voltage	V	230–460 Vac	230–460 Vac	230–460 Vac
Mains frequency	Hz	50/60 Hz	50/60 Hz	50/60 Hz
Rated operation current AC 53	I _e	16	24	32
Motor Power Ratings				
200 V	hp	3	5	10
230 V	hp	5	7.5	10
480 V	hp	10	15	25
230 V	kW	4	5.5	7.5
400 V	kW	7.5	11	15
Overload cycle according to EN 60947-4-2		16A: AC53a; 3-5; 75-10	24A: AC53a; 3-5; 75-10	32A: AC53a; 3-5; 75-10

DS7 Soft Start Controllers, continued

Rated Control Circuit

Voltage 24 Vac/Vdc Voltage 110/230 Vac Voltage 24 Vdc	Unit	DS7-340SX016N0-N DS7-342SX016N0-N DS7-34DSX016N0-D	DS7-340SX024N0-N DS7-342SX024N0-N DS7-34DSX024N0-D	DS7-340SX032N0-N DS7-342SX032N0-N DS7-34DSX032N0-D
---	------	--	--	--

Wire Specifications

Power terminals				
Single conductor—solid or stranded	AWG	18–6	18–6	18–6
Terminal torque	lb-in	11	11	11
Control Signals				
Single conductor—solid or stranded	AWG	18–10	18–10	18–10
Terminal torque	lb-in	11	11	11

Power Section

Rated impulse withstand voltage	U_{imp} 1.2/50 s	4 kV	4 kV	4 kV
Rated insulation voltage		500	500	500

Control Commands—Vac/Vdc

Supply voltage control board U_s nominal	Vac/Vdc	20.4–26.4	20.4–26.4	20.4–26.4
Current consumption at 24 Vac/Vdc	mA	1.6	1.6	1.6
Pick-up voltage		+17.3–+27	+17.3–+27	+17.3–+27
Drop-out voltage		+3–0	+3–0	+3–0

Relay Outputs

Number of relays		2 (TOR, Ready)	2 (TOR, Ready)	2 (TOR, Ready)
Maximum voltage	Vac	250	250	250
Maximum current	A	1	1	1

Soft Start Functions

Ramp times				
Start ramp	s	1–30	1–30	1–30
Stop ramp	s	0–30	0–30	0–30
Initial voltage % line voltage				
DS7-342...		30–92%	30–92%	30–92%
DS7-340...		30–100%	30–100%	30–100%
DS7-34D...		30–92%	30–92%	30–92%

Control Commands—Vac

Supply voltage control board U_s nominal	Vac	102–253	102–253	102–253
Current consumption at 102–253 Vac	mA	4	4	4
Pick-up voltage	Vac	102–230	102–230	102–230
Drop-out voltage	Vac	0–28	0–28	0–28

Relay Outputs

Number of relays		2 (TOR, Run)	2 (TOR, Run)	2 (TOR, Run)
Maximum voltage	Vac	250	250	250
Maximum current	A	3	3	3

Soft Start Functions

Ramp times				
Start ramp	s	1–30	1–30	1–30
Stop ramp	s	0–30	0–30	0–30
Initial voltage % line voltage		30–92%	30–92%	30–92%

DS7 Soft Start Controllers, continued

Rated Control Circuit

Voltage 24 Vac/Vdc Voltage 110/230 Vac Voltage 24 Vdc	Unit	DS7-340SX041N0-N DS7-342SX041N0-N DS7-34DSX041N0-D	DS7-340SX055N0-N DS7-342SX055N0-N DS7-34DSX055N0-D	DS7-340SX070N0-N DS7-342SX070N0-N DS7-34DSX070N0-D	DS7-340SX081N0-N DS7-342SX081N0-N DS7-34DSX081N0-D
---	------	--	--	--	--

General

Standards		IEC/EN 60947-4-2; GB14048.6; UL508; CSA-C22.2 No 0-M91; CSA-C22.2 No 14-05 CE marking	IEC/EN 60947-4-2; GB14048.6; UL508; CSA-C22.2 No 0-M91; CSA-C22.2 No 14-05 CE marking	IEC/EN 60947-4-2; GB14048.6; UL508; CSA-C22.2 No 0-M91; CSA-C22.2 No 14-05 CE marking	IEC/EN 60947-4-2; GB14048.6; UL508; CSA-C22.2 No 0-M91; CSA-C22.2 No 14-05 CE marking
Certifications/markings		UL/CE/CSA/C-Tick	UL/CE/CSA/C-Tick	UL/CE/CSA/C-Tick	UL/CE/CSA/C-Tick
Ambient temperature (operation)	°C	0 to 40 °C, above 40 °C de-rate linearly by 1% of rated current per Celsius to 60 °C –40 to +40 °C for low temperature version	0 to 40 °C, above 40 °C de-rate linearly by 1% of rated current per Celsius to 60 °C –40 to +40 °C for low temperature version	0 to 40 °C, above 40 °C de-rate linearly by 1% of rated current per Celsius to 60 °C –40 to +40 °C for low temperature version	0 to 40 °C, above 40 °C de-rate linearly by 1% of rated current per Celsius to 60 °C –40 to +40 °C for low temperature version
Ambient temperature (storage)	°C	–25 to 55 °C	–25 to 55 °C	–25 to 55 °C	–25 to 55 °C
Altitude		0–1000 m, above 1000 m de-rate linearly by 2.5% of rated current per 100 m to a maximum of 2000 m	0–1000 m, above 1000 m de-rate linearly by 2.5% of rated current per 100 m to a maximum of 2000 m	0–1000 m, above 1000 m de-rate linearly by 2.5% of rated current per 100 m to a maximum of 2000 m	0–1000 m, above 1000 m de-rate linearly by 2.5% of rated current per 100 m to a maximum of 2000 m
Installation		Vertical	Vertical	Vertical	Vertical
Protection class		IP20	IP20	IP20	IP20
Protection class applies to the front and operator control and display elements. Protection type from all sides is IP00.		With optional covers from the NZM range, protection type IP40 from all sides can be achieved	With optional covers from the NZM range, protection type IP40 from all sides can be achieved	With optional covers from the NZM range, protection type IP40 from all sides can be achieved	With optional covers from the NZM range, protection type IP40 from all sides can be achieved
Busbar tag shroud		Back of hand and finger-proof (from front face)	Back of hand and finger-proof (from front face)	Back of hand and finger-proof (from front face)	Back of hand and finger-proof (from front face)
Overvoltage category/ pollution degree		II/2	II/2	II/2	II/2
Shock resistance		8 g/11 ms	8 g/11 ms	8 g/11 ms	8 g/11 ms
Vibration resistance according to EN 60721-3-2		2M2	2M2	2M2	2M2
Mean heat dissipation at rated duty cycle	W	7	10	13	18
Radio interference		B	B	B	B
Dimensions (W x H x D)					
DS7-340... DS7-342... and DS7-34D...	in (mm)	3.66 x 6.89 x 5.47 (93 x 175 x 139)	3.66 x 6.89 x 5.47 (93 x 175 x 139)	3.66 x 6.89 x 5.47 (93 x 175 x 139)	3.66 x 6.89 x 5.47 (93 x 175 x 139)
Weight					
DS7-340... DS7-342... and DS7-34D...	lb (kg)	3.97 (1.8)	3.97 (1.8)	3.97 (1.8)	3.97 (1.8)
Main Circuit					
Rated operational voltage	V	230–460 Vac	230–460 Vac	230–460 Vac	230–460 Vac
Mains frequency	Hz	50/60 Hz	50/60 Hz	50/60 Hz	50/60 Hz
Rated operation current AC 53	I _e	41	55	70	81
Motor Power Ratings					
200 V	hp	10	15	20	25
230 V	hp	10	20	25	30
480 V	hp	30	40	50	60
230 V	kW	11	15	15	22
400 V	kW	22	30	37	45
Overload cycle according to EN 60947-4-2		41A: AC53a; 3-5; 75-10	55A: AC53a; 3-5; 75-10	70A: AC53a; 3-5; 75-10	81A: AC53a; 3-5; 75-10

DS7 Soft Start Controllers, continued

Rated Control Circuit

Voltage 24 Vac/Vdc Voltage 110/230 Vac Voltage 24 Vdc	Unit	DS7-340SX041N0-N DS7-342SX041N0-N DS7-34DSX041N0-D	DS7-340SX055N0-N DS7-342SX055N0-N DS7-34DSX055N0-D	DS7-340SX070N0-N DS7-342SX070N0-N DS7-34DSX070N0-D	DS7-340SX081N0-N DS7-342SX081N0-N DS7-34DSX081N0-D
---	------	--	--	--	--

Wire Specifications

Power terminals					
Single conductor—solid or stranded	AWG	12–2/0	12–2/0	12–2/0	12–2/0
Terminal torque	lb-in	53–80	53–80	53–80	53–80
Control signals					
Single conductor—solid or stranded	AWG	18–10	18–10	18–10	18–10
Terminal torque	lb-in	11	11	11	11

Power Section

Rated impulse withstand voltage	U_{imp} 1.2/50 s	4 kV	4 kV	4 kV	4 kV
Rated insulation voltage		500	500	500	500

Control Commands—24 Vac/Vdc

Supply voltage control board U_s nominal	Vac/Vdc	20.4–26.4	20.4–26.4	20.4–26.4	20.4–26.4
Current consumption at 24 Vac/Vdc	mA	65	65	65	65
Pick-up voltage		+17.3–+27	+17.3–+27	+17.3–+27	+17.3–+27
Drop-out voltage		+3–0	+3–0	+3–0	+3–0

Relay Outputs

Number of relays		2 (TOR)	2 (TOR)	2 (TOR)	2 (TOR)
Maximum voltage	Vac	250	250	250	250
Maximum current	A	1	1	1	1

Soft Start Functions

Ramp times					
Start ramp	s	1–30	1–30	1–30	1–30
Stop ramp	s	0–30	0–30	0–30	0–30
Initial voltage % line voltage					
DS7-342...		30–92%	30–92%	30–92%	30–92%
DS7-340...		30–100%	30–100%	30–100%	30–100%
DS7-34D...		30–92%	30–92%	30–92%	30–92%

Control Commands—110–230 Vac

Supply voltage control board U_s nominal	Vac	102–253	102–253	102–253	102–253
Current consumption at 24 Vac/Vdc	mA	14	14	14	14
Pick-up voltage	Vac	102–230	102–230	102–230	102–230
Drop-out voltage	Vac	0–28	0–28	0–28	0–28

Relay Outputs

Number of relays		2 (TOR)	2 (TOR)	2 (TOR)	2 (TOR)
Maximum voltage	Vac	250	250	250	250
Maximum current	A	3	3	3	3

Soft Start Functions

Ramp times					
Start ramp	s	1–30	1–30	1–30	1–30
Stop ramp	s	0–30	0–30	0–30	0–30
Initial voltage % line voltage					
		30–92%	30–92%	30–92%	30–92%

DS7 Soft Start Controllers, continued

Rated Control Circuit

Voltage 24 Vac/Vdc Voltage 110/230 Vac Voltage 24 Vdc	Unit	DS7-340SX100N0-N DS7-342SX100N0-N DS7-34DSX100N0-D	DS7-340SX135N0-N DS7-342SX135N0-N DS7-34DSX135N0-D	DS7-340SX160N0-N DS7-342SX160N0-N DS7-34DSX160N0-D	DS7-340SX200N0-N DS7-342SX200N0-N DS7-34DSX200N0-D
---	------	--	--	--	--

General

Standards		IEC/EN 60947-4-2; GB14048.6; UL508; CSA-C22.2 No 0-M91; CSA-C22.2 No 14-05 CE marking	IEC/EN 60947-4-2; GB14048.6; UL508; CSA-C22.2 No 0-M91; CSA-C22.2 No 14-05 CE marking	IEC/EN 60947-4-2; GB14048.6; UL508; CSA-C22.2 No 0-M91; CSA-C22.2 No 14-05 CE marking	IEC/EN 60947-4-2; GB14048.6; UL508; CSA-C22.2 No 0-M91; CSA-C22.2 No 14-05 CE marking
Certifications/markings		UL/CE/CSA/C-Tick	UL/CE/CSA/C-Tick	UL/CE/CSA/C-Tick	UL/CE/CSA/C-Tick
Ambient temperature (operation)	°C	0 to 40 °C, above 40 °C de-rate linearly by 1% of rated current per Celsius to 60 °C –40 to +40 °C for low temperature version	0 to 40 °C, above 40 °C de-rate linearly by 1% of rated current per Celsius to 60 °C –40 to +40 °C for low temperature version	0 to 40 °C, above 40 °C de-rate linearly by 1% of rated current per Celsius to 60 °C –40 to +40 °C for low temperature version	0 to 40 °C, above 40 °C de-rate linearly by 1% of rated current per Celsius to 60 °C –40 to +40 °C for low temperature version
Ambient temperature (storage)	°C	–25 to 55 °C	–25 to 55 °C	–25 to 55 °C	–25 to 55 °C
Altitude		0–1000 m, above 1000 m de-rate linearly by 2.5% of rated current per 100 m to a maximum of 2000 m	0–1000 m, above 1000 m de-rate linearly by 2.5% of rated current per 100 m to a maximum of 2000 m	0–1000 m, above 1000 m de-rate linearly by 2.5% of rated current per 100 m to a maximum of 2000 m	0–1000 m, above 1000 m de-rate linearly by 2.5% of rated current per 100 m to a maximum of 2000 m
Installation		Vertical	Vertical	Vertical	Vertical
Protection class		IP20	IP20	IP20	IP20
Protection class applies to the front and operator control and display elements. Protection type from all sides is IP00.		With optional covers from the NZM range, protection type IP40 from all sides can be achieved	With optional covers from the NZM range, protection type IP40 from all sides can be achieved	With optional covers from the NZM range, protection type IP40 from all sides can be achieved	With optional covers from the NZM range, protection type IP40 from all sides can be achieved
Busbar tag shroud		Back of hand and finger-proof (from front face)	Back of hand and finger-proof (from front face)	Back of hand and finger-proof (from front face)	Back of hand and finger-proof (from front face)
Overvoltage category/ pollution degree		II/2	II/2	II/2	II/2
Shock resistance		8g/11ms	8g/11ms	8g/11ms	8g/11ms
Vibration resistance according to EN 60721-3-2		2M2	2M2	2M2	2M2
Mean heat dissipation at rated duty cycle	W	25	24	30	42
Radio interference		B	B	B	B
Dimensions (W x H x D)					
DS7-340... DS7-342... and DS7-34D...	in (mm)	3.66 x 6.89 x 5.47 (93 x 175 x 139)	4.25 x 8.46 x 7.01 (108 x 215 x 178)	4.25 x 8.46 x 7.01 (108 x 215 x 178)	4.25 x 8.46 x 7.01 (108 x 215 x 178)
Weight					
DS7-340... DS7-342... and DS7-34D...	lb (kg)	3.97 (1.8)	8.16 (3.7)	8.16 (3.7)	8.16 (3.7)
Main Circuit					
Rated operational voltage	V	230–460 Vac	230–460 Vac	230–460 Vac	230–460 Vac
Mains frequency	Hz	50/60 Hz	50/60 Hz	50/60 Hz	50/60 Hz
Rated operation current AC 53	I _e	100	135	160	200
Motor Power Ratings					
200 V	hp	30	40	50	60
230 V	hp	30	50	60	75
480 V	hp	75	100	125	150
230 V	kW	30	30	45	55
400 V	kW	55	75	90	110
Overload cycle according to EN 60947-4-2		100A: AC53a; 3-5; 75-10	135A: AC53a; 3-5; 75-10	160A: AC53a; 3-5; 75-10	200A: AC53a; 3-5; 75-10

DS7 Soft Start Controllers, continued

Rated Control Circuit

Voltage 24 Vac/Vdc Voltage 110/230 Vac Voltage 24 Vdc	Unit	DS7-340SX100N0-N DS7-342SX100N0-N DS7-34DSX100N0-D	DS7-340SX135N0-N DS7-342SX135N0-N DS7-34DSX135N0-D	DS7-340SX160N0-N DS7-342SX160N0-N DS7-34DSX160N0-D	DS7-340SX200N0-N DS7-342SX200N0-N DS7-34DSX200N0-D
---	------	--	--	--	--

Wire Specifications

Power terminals					
Single conductor—solid or stranded	AWG	12–2/0	12–350 kcmil	12–350 kcmil	12–350 kcmil
Terminal torque	lb-in	53–80	44–123	44–123	44–123
Control signals					
Single conductor—solid or stranded	AWG	18–10	18–10	18–10	18–10
Terminal torque	lb-in	11	11	11	11

Power Section

Rated impulse withstand voltage	U_{imp} 1.2/50 s	4 kV	4 kV	4 kV	4 kV
Rated insulation voltage		500	500	500	500

Control Commands—24 Vac/Vdc

Supply voltage control board U_s nominal	Vac/Vdc	20.4–26.4	20.4–26.4	20.4–26.4	20.4–26.4
Current consumption at 24 Vac/Vdc	mA	65	65	65	65
Pick-up voltage		+17.3–+27	+17.3–+27	+17.3–+27	+17.3–+27
Drop-out voltage		+3–0	+3–0	+3–0	+3–0

Relay Outputs

Number of relays		2 (TOR)	2 (TOR)	2 (TOR)	2 (TOR)
Maximum voltage	Vac	250	250	250	250
Maximum current	A	1	1	1	1

Soft Start Functions

Ramp times					
Start ramp	s	1–30	1–30	1–30	1–30
Stop ramp	s	0–30	0–30	0–30	0–30
Initial voltage % line voltage					
DS7-342...		30–92%	30–92%	30–92%	30–92%
DS7-340...		30–100%	30–100%	30–100%	30–100%
DS7-34D...		30–92%	30–92%	30–92%	30–92%

Control Commands—110–230 Vac

Supply voltage control board U_s nominal	Vac	102–253	102–253	102–253	102–253
Current consumption at 24 Vac/Vdc	mA	14	14	14	14
Pick-up voltage	Vac	102–230	102–230	102–230	102–230
Drop-out voltage	Vac	0–28	0–28	0–28	0–28

Relay Outputs

Number of relays		2 (TOR)	2 (TOR)	2 (TOR)	2 (TOR)
Maximum voltage	Vac	250	250	250	250
Maximum current	A	3	3	3	3

Soft Start Functions

Ramp times					
Start ramp	s	1–30	1–30	1–30	1–30
Stop ramp	s	0–30	0–30	0–30	0–30
Initial voltage % line voltage		30–92%	30–92%	30–92%	30–92%

1.1

Reduced Voltage Motor Starters

Solid-State Controllers

1

Dimensions

Approximate Dimensions in Inches (mm)

Frame 1

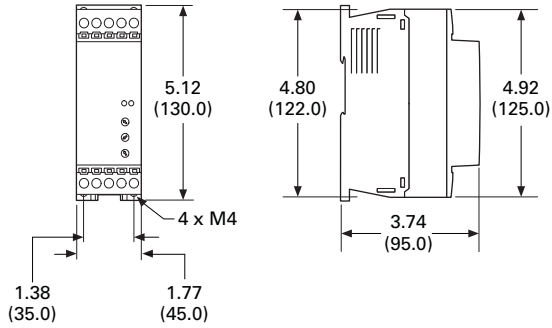

Catalog Numbers

DS7-340SX004N0-N	DS7-342SX004N0-N
DS7-340SX007N0-N	DS7-342SX007N0-N
DS7-340SX009N0-N	DS7-342SX009N0-N
DS7-340SX012N0-N	DS7-342SX012N0-N

Frame 2

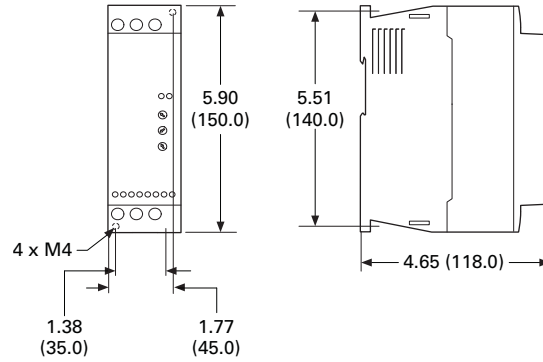

Catalog Numbers

DS7-340SX016N0-N	DS7-342SX016N0-N
DS7-340SX024N0-N	DS7-342SX024N0-N
DS7-340SX032N0-N	DS7-342SX032N0-N

Frame 1—SmartWire-DT

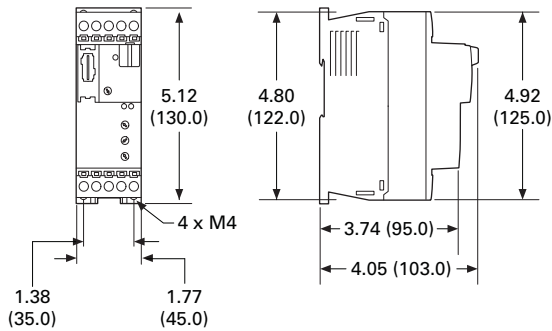

Catalog Numbers

DS7-34DSX004N0-D	DS7-34DSX009N0-D
DS7-34DSX007N0-D	DS7-34DSX012N0-D

Frame 2—SmartWire-DT

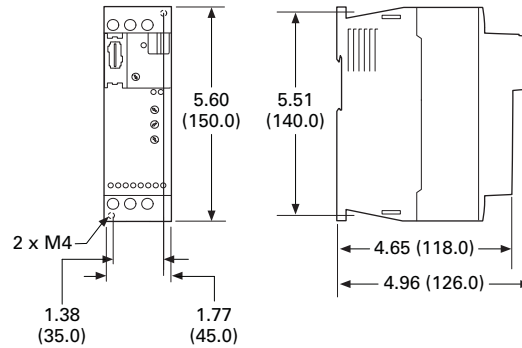

Catalog Numbers

DS7-34DSX016N0-D
DS7-34DSX024N0-D
DS7-34DSX032N0-D

Frame 3—SmartWire-DT and Standard (Non SmartWire-DT)

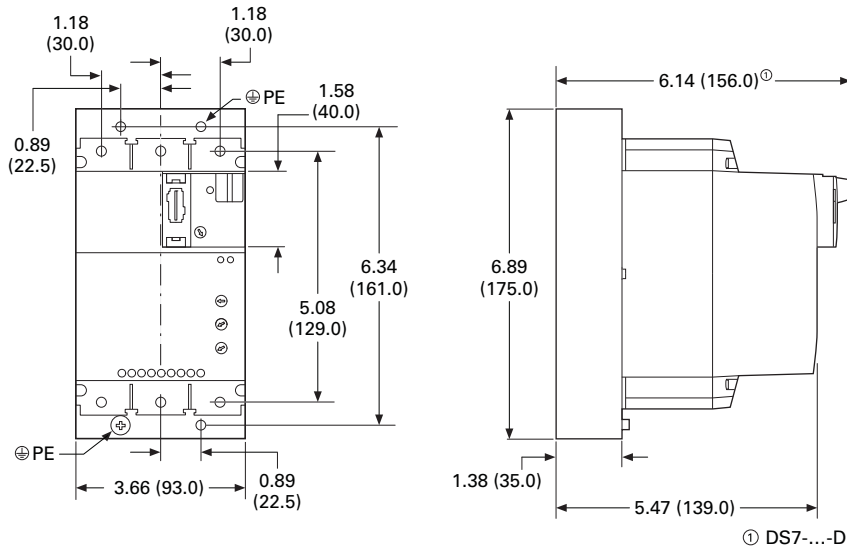

Catalog Numbers

DS7-340SX041N0-N	DS7-342SX041N0-N	DS7-34DSX041N0-D
DS7-340SX055N0-N	DS7-342SX055N0-N	DS7-34DSX055N0-D
DS7-340SX070N0-N	DS7-342SX070N0-N	DS7-34DSX070N0-D
DS7-340SX081N0-N	DS7-342SX081N0-N	DS7-34DSX081N0-D
DS7-340SX100N0-N	DS7-342SX100N0-N	DS7-34DSX100N0-D

Frame 4—SmartWire-DT and Standard (Non SmartWire-DT)

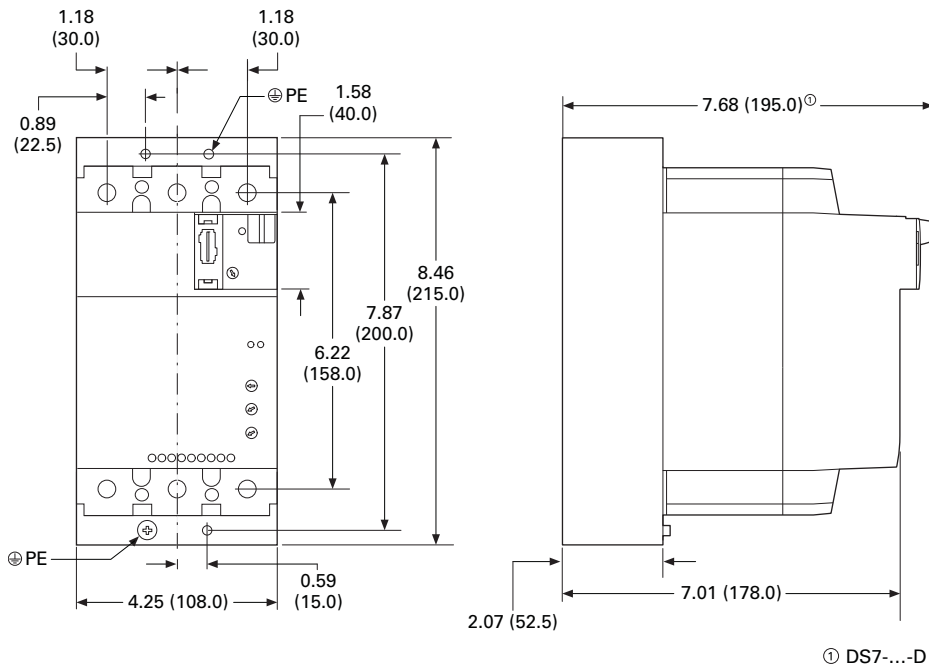

Catalog Numbers

DS7-342SX135N0-N	DS7-340SX135N0-N	DS7-34DSX135N0-D
DS7-342SX160N0-N	DS7-340SX160N0-N	DS7-34DSX160N0-D
DS7-342SX200N0-N	DS7-340SX200N0-N	DS7-34DSX200N0-D

Type S701 Soft Start Controllers



Contents

<i>Description</i>	<i>Page</i>
DS7 Soft Start Controllers	V6-T1-3
Type S701 Soft Start Controllers	
Standards and Certifications	V6-T1-27
Catalog Number Selection	V6-T1-27
Product Selection	V6-T1-27
Technical Data and Specifications	V6-T1-28
Dimensions	V6-T1-31
Type S701 Soft Start Controllers with Auxiliary Contact	V6-T1-32
Type S701 Soft Start Controllers with Brake	V6-T1-35
Type S511 Semiconductor Reversing Contactors	V6-T1-38

Type S701 Soft Start Controllers

Product Description

The S701 device is a reduced voltage soft start controller designed to control acceleration and deceleration of three-phase motors. The S701 provides the user with the ability to adjust initial torque, ramp up and down time, and also select kick start for high inertial loads.

Application Description

The S701 line of soft start controllers is specifically designed to be a low cost option for soft starting small (15 hp and down) three-phase motors. The S701 unit controls current on two of three motor phases to control the torque being applied to the motor, allowing for smooth starting of a motor. The S701 is designed to be used with a manual motor starter or a full voltage starter. These devices provide the necessary overload protection for the motor and also provide line isolation for the motor. Short-circuit protection can be provided by fuses or circuit breakers.

Features

- Rated operational voltage up to 600 Vac
- Control voltage range from 24–480 Vac/Vdc
- Adjustable ramp times (0.5–10 seconds)
- Adjustable initial torque control (0–85%)
- Kick start feature
- Soft stop (0.5–10 seconds)
- Unlimited number of START/STOP operations per hour
- IP20 finger protection
- Fractional to 15 hp motors at 480 V (20 hp at 600 V)

Benefits

- Reduced wear on belts, gears, chains, clutches, shafts and bearings
- Allows for controlling the inrush current to the motor
- Reduced water-hammer in pumping applications
- Less shock to product on conveyor lines and material handling gear

Standards and Certifications

- IEC 947 compliant
- EN 60947-4-2
- CE marked
- CSA certified
- UL listed (E108212)
- cUL listed



Catalog Number Selection

S701 Soft Starters

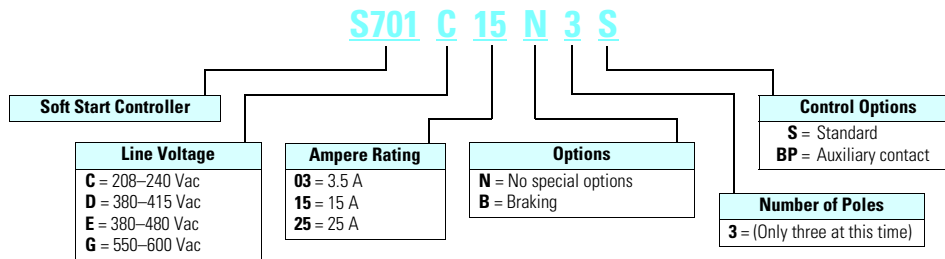

Product Selection

S701E15N3S

Soft Start Controllers



S701E25N3S



Rated Current	Line Voltage	Control Voltage (Vac/Vdc)	Three-Phase Motor												Catalog Number	
			kW Rating (50 Hz)			hp Rating (60 Hz)										
			230 V	380–400 V	440 V	200 V	230 V	460 V	575 V	1.0 SF	1.15 SF	1.0 SF	1.15 SF			
3.5	208–240	24–230	7.5	N/A	N/A	1	1	1	1	N/A	N/A	N/A	N/A	N/A	N/A	S701C03N3S
3.5	380–415	24–415	N/A	1.1	N/A	N/A	N/A	N/A	N/A	1-1/2	1-1/2	N/A	N/A	N/A	N/A	S701D03N3S
3.5	440–480	24–480	N/A	N/A	1.5	N/A	N/A	N/A	N/A	2	2	N/A	N/A	N/A	N/A	S701E03N3S
3.5	500–600	24–480	N/A	N/A	N/A	N/A	N/A	N/A	N/A	N/A	N/A	2	2	N/A	N/A	S701G03N3S
15	208–240	24–230	4	N/A	N/A	3	3	3	3	N/A	N/A	N/A	N/A	N/A	N/A	S701C15N3S
15	380–480	24–480	N/A	5.5	7.5	N/A	N/A	N/A	N/A	10	7-1/2	N/A	N/A	N/A	N/A	S701E15N3S
15	500–600	24–480	N/A	N/A	N/A	N/A	N/A	N/A	N/A	N/A	N/A	10	10	N/A	N/A	S701G15N3S
25	208–240	24–230	7.5	N/A	N/A	5	5	7-1/2	5	N/A	N/A	N/A	N/A	N/A	N/A	S701C25N3S
25	380–480	24–480	N/A	11	12.5	N/A	N/A	N/A	N/A	15	15	N/A	N/A	N/A	N/A	S701E25N3S
25	500–600	24–480	N/A	N/A	N/A	N/A	N/A	N/A	N/A	N/A	N/A	20	20	N/A	N/A	S701G25N3S

Technical Data and Specifications

Soft Starters—S701...03N3S

Description	S701C03N3S	S701D03N3S	S701E03N3S	S701G03N3S
Maximum current capacity	3.5	3.5	3.5	3.5
Trip Class				
10A	3.5	3.5	3.5	3.5
10	3.5	3.5	3.5	3.5
20	2.8	2.8	2.8	2.8
30	2.1	2.1	2.1	2.1
Electrical Characteristics				
Line voltage (Vac)	208–240	380–415	440–480	500–600
Operating frequency (Hz)	50/60	50/60	50/60	50/60
Leakage current	5 mA AC max.	5 mA AC max.	5 mA AC max.	5 mA AC max.
Minimum operational current	50 mA	50 mA	50 mA	50 mA
Control voltage (Vac/Vdc)	24–230	24–415	24–480	24–480
Pickup voltage max.	20.4 Vac/Vdc	20.4 Vac/Vdc	20.4 Vac/Vdc	20.4 Vac/Vdc
Dropout voltage min.	5 Vac/Vdc	5 Vac/Vdc	5 Vac/Vdc	5 Vac/Vdc
Max. control current for no operation	1 mA	1 mA	1 mA	1 mA
Response time max.	70 ms	70 ms	70 ms	70 ms
Control Characteristics				
Ramp time (secs)	0.5–10	0.5–10	0.5–10	0.5–10
Ramp settings (% LRT)	85%	85%	85%	85%
Kick start settings (% LRT)	85%	85%	85%	85%
Soft stop (secs)	0.5–10	0.5–10	0.5–10	0.5–10
Environment Characteristics				
Temperature—operating (no derating)	–30 ° to 40 °C	–30 ° to 40 °C	–30 ° to 40 °C	–30 ° to 40 °C
Current rating 50 °C	N/A	N/A	N/A	N/A
Limited duty cycle 50 °C	N/A	N/A	N/A	N/A
Current rating 60 °C	N/A	N/A	N/A	N/A
Limited duty cycle 60 °C	N/A	N/A	N/A	N/A
Temperature—storage	–30 ° to 80 °C	–30 ° to 80 °C	–30 ° to 80 °C	–30 ° to 80 °C
Altitude (meters)—no derating	2000	2000	2000	2000
Humidity	95% noncondensing	95% noncondensing	95% noncondensing	95% noncondensing
Operating position (no derating)	Vertical ±30 °	Vertical ±30 °	Vertical ±30 °	Vertical ±30 °
Impulse withstand voltage IEC 947-4-1	4000 V	4000 V	4000 V	4000 V
Rated insulation voltage (Ui)	660 V	660 V	660 V	660 V
Installation category	III	III	III	III
Vibration	IEC 68-2-6 5g 10–150 Hz	IEC 68-2-6 5g 10–150 Hz	IEC 68-2-6 5g 10–150 Hz	IEC 68-2-6 5g 10–150 Hz
Power dissipation for intermittent operation	4 W/A x duty cycle	4 W/A x duty cycle	4 W/A x duty cycle	4 W/A x duty cycle
Power dissipation for continuous operation	4 W/A x duty cycle	4 W/A x duty cycle	4 W/A x duty cycle	4 W/A x duty cycle
Cooling method	Natural convection	Natural convection	Natural convection	Natural convection
Degree of protection	IP20	IP20	IP20	IP20
Pollution degree	3	3	3	3
Agency approvals	UL, cUL, CE	UL, cUL, CE	UL, cUL, CE	UL, cUL, CE

Soft Starters—S701...15N3S

Description	S701C15N3S	S701E15N3S	S701G15N3S
Maximum current capacity	15	15	15
Trip Class			
10A	15	15	15
10	15	15	15
20	12	12	12
30	10	10	10
Electrical Characteristics			
Line voltage (Vac)	208–240	380–480	500–600
Operating frequency (Hz)	50/60	50/60	50/60
Leakage current	5 mA AC max.	5 mA AC max.	5 mA AC max.
Minimum operational current	50 mA	50 mA	50 mA
Control voltage (Vac/Vdc)	24–230	24–480	24–480
Pickup voltage max.	20.4 Vac/Vdc	20.4 Vac/Vdc	20.4 Vac/Vdc
Dropout voltage min.	5 Vac/Vdc	5 Vac/Vdc	5 Vac/Vdc
Max. control current for no operation	1 mA	1 mA	1 mA
Response time max.	70 ms	70 ms	70 ms
Control Characteristics			
Ramp time (secs)	0.5–10	0.5–10	0.5–10
Ramp settings (% LRT)	85%	85%	85%
Kick start settings (% LRT)	85%	85%	85%
Soft stop (secs)	0.5–10	0.5–10	0.5–10
Environment Characteristics			
Temperature—operating (no derating)	–30 ° to 40 °C	–30 ° to 40 °C	–30 ° to 40 °C
Current rating 50 °C	12.5 A	12.5 A	12.5 A
Limited duty cycle 50 °C	15 A on-time max. 15 min. duty cycle max. 0.8	15 A on-time max. 15 min. duty cycle max. 0.8	15 A on-time max. 15 min. duty cycle max. 0.8
Current rating 60 °C	10 A	10 A	10 A
Limited duty cycle 60 °C	15A on-time max. 15 min. duty cycle max. 0.65	15 A on-time max. 15 min. duty cycle max. 0.65	15 A on-time max. 15 min. duty cycle max. 0.65
Temperature—storage	–30 ° to 80 °C	–30 ° to 80 °C	–30 ° to 80 °C
Altitude (meters)—no derating	2000	2000	2000
Humidity	95% noncondensing	95% noncondensing	95% noncondensing
Operating position (no derating)	Vertical ±30 °	Vertical ±30 °	Vertical ±30 °
Impulse withstand voltage IEC 947-4-1	4000 V	4000 V	4000 V
Rated insulation voltage (Ui)	660 V	660 V	660 V
Installation category	III	III	III
Vibration	IEC 68-2-6 5g 10–150 Hz	IEC 68-2-6 5g 10–150 Hz	IEC 68-2-6 5g 10–150 Hz
Power dissipation for intermittent operation	2 W/A x duty cycle	2 W/A x duty cycle	2 W/A x duty cycle
Power dissipation for continuous operation	2 W/A	2 W/A	2 W/A
Cooling method	Natural convection	Natural convection	Natural convection
Degree of protection	IP20	IP20	IP20
Pollution degree	3	3	3
Agency approvals	UL, CSA, CE	UL, CSA, CE	UL, CSA, CE

Soft Starters—S701...25N3S

Description	S701C25N3S	S701E25N3S	S701G25N3S
Maximum current capacity	25	25	25
Trip Class			
10A	25	25	25
10	25	25	25
20	20	20	20
30	15	15	15
Electrical Characteristics			
Line voltage (Vac)	208–240	380–480	500–600
Operating frequency (Hz)	50/60	50/60	50/60
Leakage current	5 mA AC max.	5 mA AC max.	5 mA AC max.
Minimum operational current	50 mA	50 mA	50 mA
Control voltage (Vac/Vdc)	24–230	24–480	24–480
Pickup voltage max.	20.4 Vac/Vdc	20.4 Vac/Vdc	20.4 Vac/Vdc
Dropout voltage min.	5 Vac/Vdc	5 Vac/Vdc	5 Vac/Vdc
Max. control current for no operation	1 mA	1 mA	1 mA
Response time max.	70 ms	70 ms	70 ms
Control Characteristics			
Ramp time (secs)	0.5–10	0.5–10	0.5–10
Ramp settings (% LRT)	85%	85%	85%
Kick start settings (% LRT)	85%	85%	85%
Soft stop (secs)	0.5–10	0.5–10	0.5–10
Environment Characteristics			
Temperature—operating (no derating)	–30 ° to 40 °C	–30 ° to 40 °C	–30 ° to 40 °C
Current rating 50 °C	20 A	20 A	20 A
Limited duty cycle 50 °C	25 A on-time max. 15 min. duty cycle max. 0.8	25 A on-time max. 15 min. duty cycle max. 0.8	25 A on-time max. 15 min. duty cycle max. 0.8
Current rating 60 °C	17 A	17 A	17 A
Limited duty cycle 60 °C	25 A on-time max. 15 min. duty cycle max. 0.65	25 A on-time max. 15 min. duty cycle max. 0.65	25 A on-time max. 15 min. duty cycle max. 0.65
Temperature—storage	–30 ° to 80 °C	–30 ° to 80 °C	–30 ° to 80 °C
Altitude (meters)—no derating	2000	2000	2000
Humidity	95% noncondensing	95% noncondensing	95% noncondensing
Operating position (no derating)	Vertical ±30 °	Vertical ±30 °	Vertical ±30 °
Impulse withstand voltage IEC 947-4-1	4000 V	4000 V	4000 V
Rated insulation voltage (Ui)	660 V	660 V	660 V
Installation category	III	III	III
Vibration	IEC 68-2-6 5g 10–150 Hz	IEC 68-2-6 5g 10–150 Hz	IEC 68-2-6 5g 10–150 Hz
Power dissipation for intermittent operation	2 W/A x duty cycle	2 W/A x duty cycle	2 W/A x duty cycle
Power dissipation for continuous operation	2 W/A	2 W/A	2 W/A
Cooling method	Natural convection	Natural convection	Natural convection
Degree of protection	IP20	IP20	IP20
Pollution degree	3	3	3
Agency approvals	UL, CSA, CE	UL, CSA, CE	UL, CSA, CE

Dimensions

Approximate Dimensions in Inches (mm)

Soft Starters—S701...N3S

Catalog Number	W	H	D	Weight in lb (kg)
S701C03N3S	0.89 (22.5)	3.94 (100)	5.01 (127)	0.6 (270)
S701D03N3S	0.89 (22.5)	3.94 (100)	5.01 (127)	0.6 (270)
S701E03N3S	0.89 (22.5)	3.94 (100)	5.01 (127)	0.6 (270)
S701G03N3S	0.89 (22.5)	3.94 (100)	5.01 (127)	0.6 (270)
S701C15N3S	1.77 (45)	3.94 (100)	5.04 (128)	1.52 (690)
S701E15N3S	1.77 (45)	3.94 (100)	5.04 (128)	1.52 (690)
S701G15N3S	1.77 (45)	3.94 (100)	5.04 (128)	1.52 (690)
S701C25N3S	3.54 (90)	3.94 (100)	5.04 (128)	2.53 (1150)
S701E25N3S	3.54 (90)	3.94 (100)	5.04 (128)	2.53 (1150)
S701G25N3S	3.54 (90)	3.94 (100)	5.04 (128)	2.53 (1150)

Type S701 Soft Start Controllers with Auxiliary Contact



Contents

Description	Page
DS7 Soft Start Controllers	V6-T1-3
Type S701 Soft Start Controllers	V6-T1-26
Type S701 Soft Start Controllers with Auxiliary Contact	
Product Selection	V6-T1-33
Technical Data and Specifications	V6-T1-33
Dimensions	V6-T1-34
Type S701 Soft Start Controllers with Brake	V6-T1-35
Type S511 Semiconductor Reversing Contactors	V6-T1-38

Type S701 Soft Start Controllers with Auxiliary Contact

Product Description

The S701 device is a reduced voltage soft start controller designed to control acceleration and deceleration of three-phase motors. With the auxiliary contact, it is possible to control an external bypass to reduce heating and increase acceleration and deceleration times.

The unit provides the user with the ability to adjust initial torque, ramp up and down time and also select kick start for high inertia loads.

Application Description

The S701 line of soft start controllers is specifically designed to be a low cost option for soft starting small (15 hp and down) three-phase motors. The auxiliary contact is designed to work in conjunction with an across-the-line contactor. The purpose of the contactor is to provide a parallel current path once the soft starter has brought the motor up to speed. Once the soft start controller reaches end of ramp, the auxiliary contact will close and send a signal to close the bypass contactor, thus providing a low impedance path for the current to the motor. The S701 unit controls current on two of three motor phases to control the torque being applied to the motor, allowing for smooth starting of a motor. The S701 is designed to be used with a manual motor protector or a full voltage starter. These devices provide the necessary overload protection for the motor and also provide line isolation for the motor. Short-circuit protection can be provided by fuses or circuit breakers.

Features

- Rated operational voltage up to 600 Vac
- Control voltage range from 24–300 Vac/Vdc
- Adjustable ramp times (0.5–20 seconds)
- Adjustable initial torque control (0–85%)
- Kick start feature (0–85% adjustment)
- Kick start for 200 ms
- Soft stop (0.5–20 seconds)
- IP20 finger protection
- Available up to 30 A (with bypass installed)
- Auxiliary contact for up-to-speed indication

Benefits

- Reduced wear on belts, gears, chains, clutches, shafts and bearings
- Bypass option allows for greater current capacity in the unit
- Bypass option helps to reduce heat in the enclosure
- Allows for controlling the inrush current to the motor
- Reduced water-hammer in pumping applications
- Less shock to product on conveyor lines and material handling gear

Standards and Certifications

- IEC 947 compliant
- EN 60947-4-2
- CE marked
- UL listed (E108212)
- cUL listed



Product Selection

For S701 catalog number selection, see **Page V6-T1-27**.

S701

Soft Start Controllers with Auxiliary Contact



Rated Current	Line Voltage	Control Voltage (Vac/Vdc)	Three-Phase Motor kW Rating (50 Hz)			hp Rating		230 V		460 V		575 V		Catalog Number
			230 V	380–400 V	440 V	200 V	1.15 SF	1.0 SF	1.15 SF	1.0 SF	1.15 SF	1.0 SF	1.15 SF	
Ratings without Bypass														
25	208–240	24–230	5.5	N/A	N/A	5	5	7-1/2	5	N/A	N/A	N/A	N/A	S701C25N3BP
25	380–480	24–480	N/A	12.5	12.5	N/A	N/A	N/A	N/A	15	15	N/A	N/A	S701E25N3BP
25	500–600	24–480	N/A	N/A	N/A	N/A	N/A	N/A	N/A	N/A	N/A	20	20	S701G25N3BP
Ratings with Bypass														
30	208–240	24–230	7.5	N/A	N/A	7-1/2	7-1/2	10	7-1/2	N/A	N/A	N/A	N/A	S701C25N3BP
30	380–480	24–480	N/A	15	15	N/A	N/A	N/A	N/A	20	15	N/A	N/A	S701E25N3BP
30	500–600	24–480	N/A	N/A	N/A	N/A	N/A	N/A	N/A	N/A	N/A	25	20	S701G25N3BP

Technical Data and Specifications

Soft Starters with Auxiliary Contact—S701...25N3BP

Description	S701C25N3BP	S701E25N3BP	S701G25N3BP
Maximum current capacity with bypass (without bypass)	30 (25)	30 (25)	30 (25)
Trip Class			
10A	30 (25)	30 (25)	30 (25)
10	30 (25)	30 (25)	30 (25)
20	24 (20)	24 (20)	24 (20)
30	19.5 (15)	19.5 (15)	19.5 (15)
Electrical Characteristics			
Line voltage (Vac)	208–240	380–480	500–600
Operating frequency (Hz)	50/60	50/60	50/60
Leakage current	5 mA AC max.	5 mA AC max.	5 mA AC max.
Minimum operational current	50 mA	50 mA	50 mA
Control voltage (Vac/Vdc)	24–230	24–480	24–480
Pickup voltage max.	20.4 Vac/Vdc	20.4 Vac/Vdc	20.4 Vac/Vdc
Dropout voltage min.	5 Vac/Vdc	5 Vac/Vdc	5 Vac/Vdc
Max. control current for no operation	1 mA	1 mA	1 mA
Response time max.	70 ms	70 ms	70 ms

Soft Starters with Auxiliary Contact—S701...25N3BP, continued

Description	S701C25N3BP	S701E25N3BP	S701G25N3BP
Control Characteristics			
Ramp time (secs)	0.5–20	0.5–20	0.5–20
Ramp settings (% LRT)	85%	85%	85%
Kick start settings (% LRT)	85%	85%	85%
Soft stop (secs)	0.5–20	0.5–20	0.5–20
Environmental Characteristics			
Temperature—operating (no derating)	–30 ° to 40 °C	–30 ° to 40 °C	–30 ° to 40 °C
Current rating 50 °C	20 A	20 A	20 A
Limited duty cycle 50 °C	25 A on-time max. 15 min. duty cycle max. 0.8	25 A on-time max. 15 min. duty cycle max. 0.8	25 A on-time max. 15 min. duty cycle max. 0.8
Current rating 60 °C	17 A	17 A	17 A
Limited duty cycle 60 °C	25 A on-time max. 15 min. duty cycle max. 0.65	25 A on-time max. 15 min. duty cycle max. 0.65	25 A on-time max. 15 min. duty cycle max. 0.65
Temperature—storage	–30 ° to 80 °C	–30 ° to 80 °C	–30 ° to 80 °C
Altitude (meters)—no derating	2000	2000	2000
Humidity	95% noncondensing	95% noncondensing	95% noncondensing
Operating position (no derating)	Vertical ±30 °	Vertical ±30 °	Vertical ±30 °
Impulse withstand voltage IEC 947-4-1	4000 V	4000 V	4000 V
Rated insulation voltage (Ui)	660 V	660 V	660 V
Installation category	III	III	III
Vibration	IEC 68-2-6 5g 10–150 Hz	IEC 68-2-6 5g 10–150 Hz	IEC 68-2-6 5g 10–150 Hz
Power dissipation for continuous operation	2 W/A without bypass	2 W/A without bypass	2 W/A without bypass
Power dissipation with semiconductor bypassed	5 W/A max. with bypass	5 W/A max. with bypass	5 W/A max. with bypass
Cooling method	Natural convection	Natural convection	Natural convection
Degree of protection	IP20	IP20	IP20
Pollution degree	3	3	3
Agency approvals	UL, cUL, CE	UL, cUL, CE	UL, cUL, CE

Dimensions

Approximate Dimensions in Inches (mm)

Soft Starters with Auxiliary Contact—S701...25N3BP

Catalog Number	W	H	D	Weight in lb (kg)
S701C25N3BP	3.54 (89.9)	3.94 (100.1)	5.04 (128.0)	2.53 (1150)
S701E25N3BP	3.54 (89.9)	3.94 (100.1)	5.04 (128.0)	2.53 (1150)
S701G25N3BP	3.54 (89.9)	3.94 (100.1)	5.04 (128.0)	2.53 (1150)

Type S701 Soft Start Controllers with Brake



Contents

Description	Page
DS7 Soft Start Controllers	V6-T1-3
Type S701 Soft Start Controllers	V6-T1-26
Type S701 Soft Start Controllers with Auxiliary Contact	V6-T1-32
Type S701 Soft Start Controllers with Brake	
Product Selection	V6-T1-36
Technical Data and Specifications	V6-T1-36
Dimensions	V6-T1-37
Type S511 Semiconductor Reversing Contactors	V6-T1-38

Type S701 Soft Start Controllers with Brake

Product Description

The S701 soft start controller with DC injection brake is designed to control acceleration and deceleration of three-phase motors. Brake current is adjustable from 0 to 50 Adc. The ramp-up feature is adjustable from 0.5 to 10 seconds. Torque adjustment is adjustable with or without break loose (kick start) function.

Application Description

The S701 line of soft start controllers is specifically designed to be a low cost option for soft starting small (15 hp and down) three-phase motors. The braking option is a DC injection system, allowing for fast stopping of a three-phase motor. The S701 unit controls current on two of the three phases to control the torque being applied to the motor, allowing for smooth starting of a motor. The S701 is designed to be used with a manual motor starter or a full voltage starter. These devices provide the necessary overload protection for the motor and also provide line isolation for the motor. Short-circuit protection can be provided by fuses or circuit breakers.

Features

- Rated operational voltage up to 480 Vac
- Control voltage range from 24 to 300 Vac/Vdc
- Adjustable ramp times (0.5–20 seconds)
- Adjustable initial torque control (0–85%)
- Kick start feature (0–85% adjustment)
- Kick start for 200 ms
- IP20 finger protection
- Braking control adjustable from 0 to 50 Adc
- Slow speed: 75% or 10% of nominal speed

Standards and Certifications

- IEC 947 compliant
- EN 60947-4-2
- CE marked
- UL listed (E108212)
- cUL listed



Benefits

- Reduced wear on bolts, gears, chains, clutches, shafts and bearings
- Braking option allows for quick stopping of loads
- Brake control can help eliminate expensive mechanical brakes
- Allows for controlling the inrush current to the motor
- Reduced water-hammer in pumping applications
- Less shock to product on conveyor lines and material handling gear

Product Selection

For S701 catalog number selection, see **Page V6-T1-27**.

S701E25B3S**Soft Start Controllers with Brake**

Rated Current	Line Voltage	Control Voltage (Vac/Vdc)	Three-Phase Motor kW Rating (50 Hz)			hp Rating 200 V		230 V		460 V		Catalog Number
			230 V	380–400 V	440 V	1.0 SF	1.15 SF	1.0 SF	1.15 SF	1.0 SF	1.15 SF	
25	208–240	24–230	5.5	N/A	N/A	5	5	7-1/2	5	N/A	N/A	S701C25B3S
25	380–480	24–480	N/A	12.5	12.5	N/A	N/A	N/A	N/A	15	15	S701E25B3S

Technical Data and Specifications**Soft Starters with Brake—S701...25B3S**

Description	S701C25B3S	S701E25B3S
Maximum current capacity	25	25
Trip Class		
10A	25	25
10	25	25
20	20	20
30	15	15
Electrical Characteristics		
Line voltage (Vac)	208–240	380–480
Operating frequency (Hz)	50/60	50/60
Leakage current	5 mA AC max.	5 mA AC max.
Minimum operational current	1A	1A
Control voltage (Vac/Vdc)	24–230	24–480
Pickup voltage max.	20.4 Vac/Vdc	20.4 Vac/Vdc
Dropout voltage min.	5 Vac/Vdc	5 Vac/Vdc
Max. control current for no operation	1 mA	1 mA
Response time max.	100 ms	100 ms
Control Characteristics		
Ramp time (secs)	0.5–10	0.5–10
Ramp settings (% LRT)	85%	85%
Kick start settings (% LRT)	85%	85%
Soft stop (secs)	0.5–10	0.5–10
Brake current	0–50 Vdc	0–50 Vdc

Soft Starters with Brake—S701...25B3S, continued

Description	S701C25B3S	S701E25B3S
Environmental Characteristics		
Temperature—operating	–30 ° to 40 °C	–30 ° to 40 °C
Current rating 50 °C	20 A	20 A
Limited duty cycle 50 °C	25 A on-time max. 15 min. duty cycle max. 0.8	25 A on-time max. 15 min. duty cycle max. 0.8
Current rating 60 °C	17 A	17 A
Limited duty cycle 60 °C	25 A on-time max. 15 min. duty cycle max. 0.65	25 A on-time max. 15 min. duty cycle max. 0.65
Temperature—storage	–30 ° to 80 °C	–30 ° to 80 °C
Altitude (meters)—no derating	2000	2000
Humidity	95% noncondensing	95% noncondensing
Operating position	Vertical ± 0 °	Vertical ± 0 °
Impulse withstand voltage IEC 947-4-1	4000 V	4000 V
Rated insulation voltage (Ui)	660 V	660 V
Installation category	III	III
Vibration	IEC 68-2-6 5g 10–150 Hz	IEC 68-2-6 5g 10–150 Hz
Power dissipation for intermittent operation	2 W/A x duty cycle	2 W/A x duty cycle
Power dissipation for continuous operation	2 W/A	2 W/A
Cooling method	Natural convection	Natural convection
Degree of protection	IP20	IP20
Pollution degree	3	3
Agency approvals	UL, cUL, CE	UL, cUL, CE

Dimensions

Approximate Dimensions in Inches (mm)

Soft Starters with Brake—S701...25B3S

Catalog Number	W	H	D	Weight in lb (kg)
S701C25B3S	3.54 (89.9)	3.94 (100.1)	5.04 (128.0)	2.53 (1150)
S701E25B3S	3.54 (89.9)	3.94 (100.1)	5.04 (128.0)	2.53 (1150)

Contents

<i>Description</i>	<i>Page</i>
DS7 Soft Start Controllers	V6-T1-3
Type S701 Soft Start Controllers	V6-T1-26
Type S701 Soft Start Controllers with Auxiliary Contact	V6-T1-32
Type S701 Soft Start Controllers with Brake	V6-T1-35
Type S511 Semiconductor Reversing Contactors	
Product Selection	V6-T1-39
Technical Data and Specifications	V6-T1-39
Dimensions	V6-T1-40

Type S511 Semiconductor Reversing Contactors

Product Description

The S511 device is a semiconductor reversing contactor designed to switch three-phase motors forward and reverse. Unicore electronics and thermal design ensures high switching capacity and long lifetime.

Application Description

The S511 line of solid-state reversing contactors is specifically designed for high speed operations or when long contactor life is required. The reversing contactors are intended for small motor applications (5 hp and below). The S511 unit can be used in a variety of applications including fans, pumps, conveyors, doors, hoists, cranes, etc. It is designed to be used with a manual motor starter or a full voltage starter. These devices provide the necessary overload protection for the motor and also provide line isolation for the motor. Short-circuit protection can be provided by fuses or circuit breakers.

Features

- Rated operational voltage up to 480 Vac
- Control voltage ranges of 5–24 Vdc and 24–240 Vac/Vdc
- Unlimited number of START/STOP operations per hour
- IP20 finger protection
- AC-3 current rating of 10A
- AC-4 current rating of 8A

Benefits

- Extremely high switching rates possible
- Very long life expectancy and no contacts or movable parts to replace
- Compact design (45 mm wide) leads to significant panel savings

Standards and Certifications

- IEC 947 compliant
- EN 60947-4-2
- CE marked
- CSA certified
- UL listed



Product Selection

Reversing Solid-State Contactors

Rated Current	Line Voltage	Control Voltage	Three-Phase Motor kW Rating (50 Hz)			hp Rating		230 V		460 V		Catalog Number
			230 V	380–400 V	440 V	200 V 1.0 SF	1.15 SF	1.0 SF	1.15 SF	1.0 SF	1.15 SF	
10	208–480	5–24 Vdc	2.2	4	4	2	2	3	2	5	5	S511E10N3D
10	208–480	24–240 Vac/Vdc	2.2	4	4	2	2	3	2	5	5	S511E10N3S

Technical Data and Specifications

Semiconductor Reversing Contactors—S511E10N3...

Description	S511E10N3D	S511E10N3S
Maximum current capacity	10	10
Trip Class		
10A	10	10
10	10	10
20	8	8
30	6.5	6.5
Electrical Characteristics		
Line Voltage (Vac)	208–480	208–480
Operating frequency (Hz)	50/60	50/60
Control voltage	5–24 Vdc	24–240 Vac/Vdc
Pickup voltage max.	4.25 Vdc	20.4 Vac/Vdc
Dropout voltage min.	1.5 Vdc	7.2 Vac/Vdc
Max. control voltage	26.4 Vdc	253 Vac/Vdc
Response time max.	1/2 cycle	1 cycle
Interlock time max.	80 ms	150 ms
Control Characteristics		
Operation current AC-3	10	10
Operation current AC-4	8	8
Duty cycle	Continuous operation	Continuous operation
Leakage current	1 mA AC max.	1 mA AC max.
Minimum operation current	10 mA AC	10 mA AC
Environmental Characteristics		
Temperature—operating	0 ° to 60 °C	0 ° to 60 °C
Temperature—storage	–20 ° to 80 °C	–20 ° to 80 °C
Altitude (meters)	2000	2000
Humidity	95% noncondensing	95% noncondensing
Operating position	Vertical ±30 °	Vertical ±30 °
Impulse withstand voltage IEC 947-4-1	4000 V	4000 V
Rated insulation voltage (Ui)	660 V	660 V
Installation category	III	III
Vibration	IEC 68-2-6 5g 10–150 Hz	IEC 68-2-6 5g 10–150 Hz
Power dissipation for intermittent operation	2.2 W/A x duty cycle	2.2 W/A x duty cycle
Power dissipation for continuous operation	2.2 W/A	2.2 W/A
Cooling method	Natural convection	Natural convection
Degree of protection	IP20	IP20
Pollution degree	3	3
Agency approvals	UL, CSA, CE	UL, CSA, CE

1.1

Reduced Voltage Motor Starters

Solid-State Controllers

1

Mounting Instructions

IMPORTANT: The controller is designed for vertical mounting in free air. If the controller is mounted horizontally, the load current must be reduced to 50% of rated current.

Recommended Mounting Distances

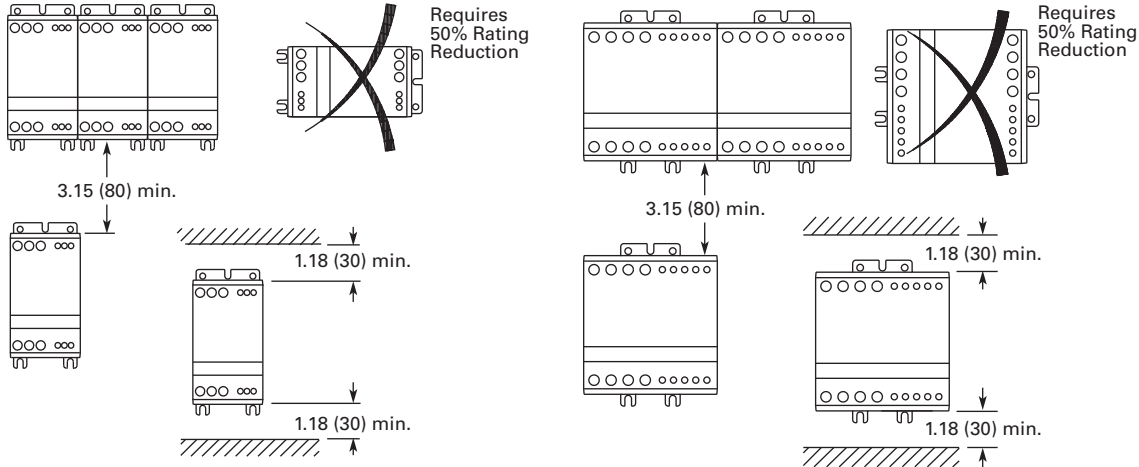

Dimensions

Approximate Dimensions in Inches (mm)

Semiconductor Reversing Contactors—S511E10N3...

Catalog Number	W	H	D	Weight in lb (kg)
S511E10N3D	1.77 (45.0)	3.94 (100.1)	5.04 (128.0)	1.52 (690)
S511E10N3S	1.77 (45.0)	3.94 (100.1)	5.04 (128.0)	1.52 (690)

Also refer to dimension drawings on **Page V6-T1-41**.

Cable Requirements and Sizing

75 °C	AWG (mm ²)	AWG (mm ²)
	18–12 (0.75–4)	20–16 (0.5–1.5)
	2–18 (2 x 1)	2 x 20–18 (2 x 0.5–0.75)
	18–10 (0.75–4)	20–16 (0.5–1.5)
	2 x 18–14 (2 x 0.75–2.5)	2 x 20–16 (2 x 0.5–1.5)
	18–10 (0.75–4)	20–16 (0.5–1.5)
	2 x 18–16 (0.75–6)	2 x 20–16 (2 x 0.5–1.5)
	Posidrive 1 4.4 in-lb. max. 0.5 Nm max.)	N/A
	4 mm 4.4 in-lb. max. (0.5 Nm max.)	3 mm 3.5 in-lb. max. (0.4 Nm max.)

Approximate Dimensions in Inches (mm)

22.5 mm Frame

S511E10N3D, S511E10N3S

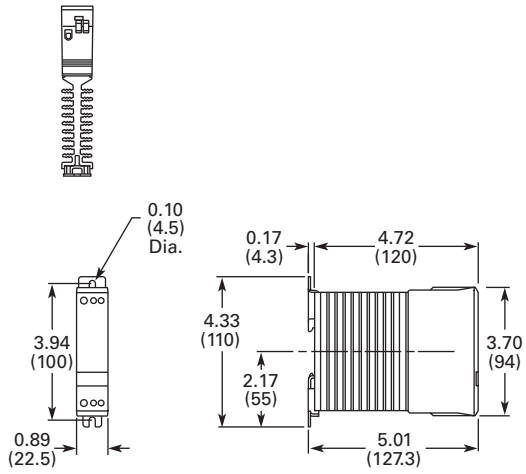

90 mm Frame

S511E10N3D, S511E10N3S

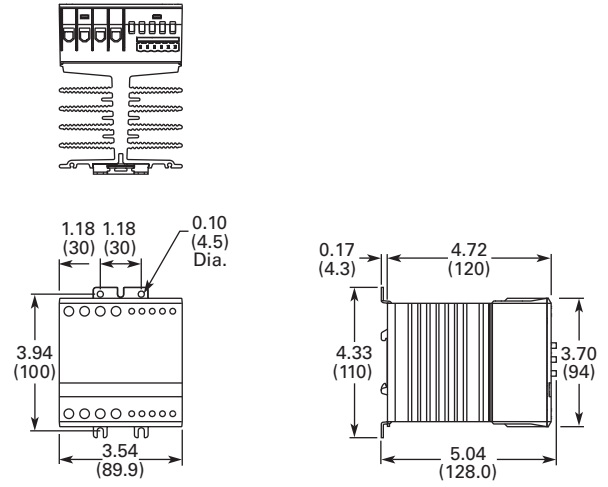

45 mm Frame

S511E10N3D, S511E10N3S

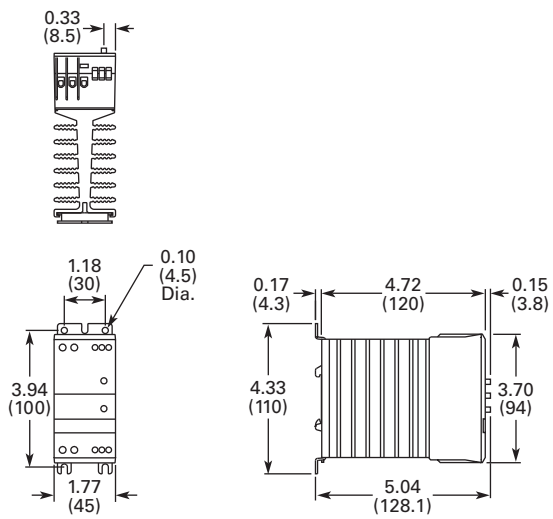

Solid-State Starters



Contents

Description

Page

Solid-State Starters	
Type S611 Soft Starters	V6-T1-43
Torque Limiters	V6-T1-59
Type S711 Soft Starters	V6-T1-61
Type S801+ Soft Starters	V6-T1-81
Type S811+ Soft Starters with DIM	V6-T1-97

Product Overview

Type S611

The S611 soft starter is a powerful combination of performance capability, application flexibility, and the industry’s best user interface experience.

Designed to control acceleration and deceleration of three-phase motors, the line is available for current ranges from 26 A through 414 A applications.

The S611 has integrated bypass and overload protection. The S611 is available as a component for panel mounting or in enclosed control—NEMA Type 1, 12, 3R, 4, 4X.

Torque Limiters

The TL device line of starting torque limiters is designed for the soft start of three-phase or single-phase motors, i.e., it allows smoother starting of all AC induction motors, thus decreasing shock and vibration problems encountered during across-the-line starts. The device is ramp-up time/torque adjustable from 0.5 to 5 seconds/0 to 85% of nominal starting torque.

Type S711

Eaton’s S711 brings simplicity to advanced functionality with its enhanced communications, metering, monitoring and diagnostic capabilities via keypad or mobile device. Eaton’s S711 line of reduced voltage soft starters is multi-functional, easy to commission and easy to use.

Designed to control the acceleration and deceleration of three-phase motors up to 575 V, the line is available from 12 A to 560 A. The S711 is designed to be a complete package, combining the silicon controlled rectifiers (SCRs), bypass contactor and overload in one compact unit.

Type S801+

Eaton’s S801+ line of reduced voltage soft starters is very compact, multi-functional, easy to install and easy to program. Designed to control acceleration and deceleration of three-phase motors, the line is available for current ranges from 11 A to 1000 A applications, and is suitable for mounting in motor control centers or in enclosed control (NEMA Type 1, 4, 4X and 12) applications.

Type S811+

Eaton’s S811+ offers all the popular features of the S801+ and adds enhanced functionality with the new DIM (Digital Interface Module), communications, metering, monitoring and diagnostics capabilities.

Eaton’s line of S811+ reduced voltage soft starters is very compact, multi-functional, easy to install and easy to set operating parameters. Designed to control the acceleration and deceleration of three-phase motors up to 690 V, the line is available from 11 A to 1000 A.

The S811+ is designed to be a complete package, combining the silicon controlled rectifiers (SCRs), bypass contactor and overload in one, very compact unit. The S811+ is available as a component for panel mounting, in motor control centers or in enclosed control (NEMA Type 1, 3R, 4, 4X, 7/9 and 12).

Type S611 Soft Starter



Contents

<i>Description</i>	<i>Page</i>
Type S611 Soft Starters	
Features and Benefits	V6-T1-44
Operation	V6-T1-47
Catalog Number Selection	V6-T1-50
Product Selection	V6-T1-51
Accessories	V6-T1-52
Replacement Parts	V6-T1-53
Technical Data and Specifications	V6-T1-54
Dimensions	V6-T1-57
Torque Limiters	V6-T1-59
Type S711 Soft Starters	V6-T1-61
Type S801+ Soft Starters	V6-T1-81
Type S811+ Soft Starters with DIM	V6-T1-97

Type S611 Soft Starters

Product Description

Eaton revolutionized the reduced voltage control marketplace with its advanced feature set and user-friendly user interface module to enhance system performance and reduce commissioning times. The S611 adds enhanced functionality with network communications, metering, monitoring and diagnostics capabilities.

The Eaton line of S611 reduced voltage soft starters is multi-functional, easy to install and easy to program. Designed to control the acceleration and deceleration of three-phase motors up to 600 V, the line is available from 26 amps through 414 amps.

The S611 is designed to be a complete package combining the SCRs, bypass contactor and overload in one unit.

Application Description

Designed to control the acceleration and deceleration of three-phase motors, the S611 soft starter uses Silicon Controlled Rectifiers (SCRs) to control the voltage to soft start and soft stop the motor. After the motor is started, internal run bypass contactors close, resulting in the motor running directly across-the-line. The built-in solid-state overload protects the motor from overload conditions with sophisticated algorithms that model true motor heating, resulting in better motor protection and fewer nuisance trips. Advanced protective and diagnostic features reduce downtime.

A voltage ramp start or current limit start is available. Kick start is available in either starting mode. The soft stop option allows for a ramp stop time that is longer than the coast to stop time. The pump control option provides a smooth transition for starting and stopping a motor and eliminating the “water-hammer” effect that can damage pipes, valves and pumps.

The S611 offers an impressive array of advanced protective features. Not only are the protective features selectable, but many offer variable settings allowing the user to fine tune the soft starter to meet specific system requirements.

The S611 has an easy to use User Interface Module (UI) that allows the user to configure the device and to read system parameters and values. The UI includes an LED display and keypad to scroll through the various parameters. The UI allows the user to modify control parameters, enable or disable protections, set communication variables, monitor system values such as line voltages and currents, and access the fault queue.

User Interface Module (UI)

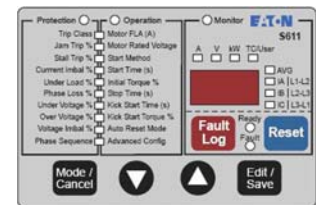

The UI can be removed from the S611 and remote mounted. Kits are available to door mount the UI, enabling users to safely configure, commission, monitor and troubleshoot the system at the electrical panel without opening the enclosure door. This will help eliminate the possibility of an arc flash incident.

Standards and Certifications

- IEC 60947-4-2
- UL listed
- CSA certified (3211 06)



Features and Benefits

- The User Interface Module (UI) provides an intuitive, easy-to-use human interface with powerful configuration capabilities to maximize system performance
- Door or device mounted UI enables users to safely configure, commission, monitor and troubleshoot the system at the electrical panel without opening the enclosure door, eliminating the possibility of an arc flash incident
- System operating parameters can be monitored enterprise-wide through a communications network. Increase uptime by providing data for process management and preventive diagnostics
- Run bypass mode greatly reduces internal heating created by the greater power dissipation in the SCRs. Bypass contactors directly connect the motor to the line and improves system efficiency by reducing internal power losses
- Internal solid-state overload protection provides accurate current measurement and trip settings. Sophisticated algorithms solve a series of differential equations that model true motor heating and cooling, resulting in superior motor overload protection while minimizing nuisance trips. Advanced selectable protective features safeguard the motor and system against a variety of system faults
- Internal run bypass contactors and overload protection eliminate the need for additional devices, reducing enclosure sizes minimizing installation and wiring time and reducing overall assembly size and cost
- Wide range of overload FLA settings (50–100% of rated frame current) and a selectable trip class (5–30) offers users the flexibility to fine tune the starter to match specific application requirements
- Variable ramp times and torque control settings provide unlimited starting configurations, allowing for maximum application flexibility
- Kick-start feature enables soft starting of high friction loads
- Soft stop control for applications where an abrupt stop of the load is not acceptable
- Pump control option with sophisticated pump algorithms on both starting and stopping that minimize the pressure surges that cause water hammer. The pump control option will maximize the life of the pump and piping systems while minimizing the downtime caused by system failure
- Six SCRs control all three motor phases, providing smooth acceleration and deceleration performance
- Soft acceleration and deceleration reduces wear on belts, gears, chains, clutches, shafts and bearings
- Reduce the peak inrush current's stress on the power system
- Minimize peak starting torque to diminish mechanical system wear and damage
- 120 Vac control voltage enhances ease of connections
- The S611 lends itself to serviceability. The printed circuit boards (PCBs) and contactors can be replaced in the field
- The S611 has built-in communication capabilities through two communications ports to connect the soft starter to a variety of networks, including Modbus (resident), DeviceNet™, PROFIBUS®, and Ethernet

Protective Features

All protective features can be configured, enabled or disabled with the UI or through the communications network.

Motor Overload

The S611 includes electronic overload protection as standard. The overload meets applicable requirements for a motor overload protective device. The overload protects the motor from over heat conditions with the use of sophisticated algorithms that model true motor heating, resulting in superior motor protection and fewer nuisance trips.

The S611 calculates a thermal memory value. A 100% value represents the maximum safe temperature of the motor. When the thermal memory value reaches 100%, an overload trip will occur removing power to the motor.

Upon trip, the S611 stores the calculated motor heating value and will not allow a motor re-start until the motor has cooled. This feature ensures the motor will not be damaged by repeated overload trip, reset and re-start cycles.

The thermal memory value can be monitored through the UI or the communications network. The thermal memory value can be of great use in determining an impending overload trip condition. Alarms can be implemented in the process monitoring system warning of an impending trip before a trip occurs halting the process. Costly system downtime can be avoided.

The trip current is adjusted to match the specific application requirements by entering the motor nameplate full load current rating and trip class. The FLA adjustment includes a 2 to 1 adjustment range. The overload trip class is adjustable from class 5 through class 30. The overload is ambient temperature compensated—meaning its trip characteristics will not vary with changes in ambient temperature. The overload protection can be enabled, disabled, or disabled on start.

Short Circuit

The use of a short circuit protective device in coordination with the S611 is required in branch motor circuits by most electrical codes. Short circuit coordination ratings with both fuses and Eaton molded case circuit breakers are available providing customers with design flexibility. The S611 has short circuit coordination ratings as an open component, an enclosed starter, and in a motor control center. The short circuit ratings can go up to 100 kA depending on application configuration.

Jam

Excessive current and torque up to locked rotor levels can occur in a jam condition. The condition can result in stress and damage to the motor, load, mechanical system, and the electrical distribution system. Jam protection prevents the stress and damage from a jam during normal run. After the motor is started, a current greater than 300% FLA setting will cause the starter to trip on a jam fault.

Stall

Excessive current and torque up to locked rotor levels can occur in a stall condition. The condition can lead to an overload trip and result in stress and damage to the motor, load, mechanical system, and the electrical distribution system. Stall protection prevents stress and damage to a motor that has not come up to speed, or stalled after the soft start time. The S611 will trip to protect the system in the event that the motor did not get to the rated speed in the defined soft start period. A current greater than 200% FLA at the end of the soft start period will cause the starter to trip on a stall fault.

Pole Over Temperature

High ambient temperatures, extended ramp times and high duty cycle conditions may cause the S611 power pole conductors to reach a temperature that exceeds their thermal rating. The S611 is equipped with sensors that monitor the temperature of the power poles. Over temperature protection occurs if the device's thermal capacity is exceeded. The soft starter will trip in over temperature conditions, preventing device failure.

The device pole temperature value can be monitored through the UI or the communications network. This feature can be of use in determining an impending over temperature trip condition. Alarms can be implemented in the process monitoring system warning of an impending trip before a trip occurs, halting the process. Costly system shutdown can be avoided.

Phase Loss

Loss of a phase can cause a significant increase in the current drawn in the remaining two phases. Phase loss can lead to motor damage before an eventual overload trip occurs. Phase loss is typically an indication of a failure in the electrical distribution system. The S611 will detect a phase loss and trip if any phase current drops below a preset value. The phase loss trip level is adjustable from 0% to 100% of the average of the other two phase levels with an adjustable trip delay of 0.1 to 60 seconds.

Phase Imbalance

Phase current or voltage imbalance can cause a significant increase in the current drawn in the remaining two phases. Phase imbalance can lead to motor damage before an eventual overload trip. Phase imbalance is typically an indication of a failure in the electrical distribution system or the motor. The S611 will detect both current and voltage phase imbalances and trip if any phase becomes imbalanced as compared to the average of the other two phases.

The phase current imbalance trip level is adjustable from 0% to 100% of the average of the current in the other two phases with an adjustable trip delay of 0.1 to 60 seconds.

The phase voltage imbalance trip level is adjustable from 0% to 100% of the average of the voltage in the other two phases with an adjustable trip delay of 0.1 to 60 seconds.

Reset Mode

The S611 can be set up for automatic or manual reset on trip. The manual reset mode requires the operator to physically press the RESET button located on the soft starter. The overload can be manually reset through the UI or through the communications network.

The automatic reset mode allows the soft starter to be automatically reset as soon as the trip condition is no longer present. With the automatic reset mode, after the fault is no longer present, the motor will be restarted as soon as a valid start signal is present.

Phase Reversal

The S611 can determine if the proper line phase sequence is present by default. The device will trip if the line phase sequence is something other than A-B-C. The S611 can be configured to operate under reversed phase conditions (A-C-B).

Shorted SCR Detection

The S611 monitors the operation of the power poles and will trip under a shorted SCR condition.

Open SCR Detection

The S611 monitors the operation of the power poles and will trip under an open SCR condition.

Low Current

Low current conditions can be a result of a loss of load or a failure in the mechanical system. The S611 has low current protection that will trip if the average RMS current falls below a preset value. The low current protection can be programmed as a percent of motor FLA from 0% to 100%.

Low Voltage

Low voltage conditions can result from disturbances in the electrical power distribution system. Low voltage conditions can cause a malfunction and damage to electrical equipment. The S611 has low voltage protection that will trip if the average RMS voltage falls below a preset value. The low voltage protection can be programmed as a percent of nominal voltage from 1% to 99% with a trip delay of 0.1 to 60 seconds.

High Voltage

High voltage conditions can result from disturbances in the electrical power distribution system. High voltage conditions can cause malfunctions or failures of electrical equipment. The S611 has high voltage protection that will trip if the average RMS voltage is greater than a preset value. The high voltage protection can be programmed as a percent of nominal voltage from 101% to 120% with a trip delay of 0.1 to 60 seconds.

Monitoring Capabilities

The S611 has an impressive array of system monitoring capabilities that allow users to access real time process and diagnostic data. This data can be viewed at the device with the UI or through a communications network. Data over a communications network can provide valuable insight into the condition of the equipment and processes. Maintenance and production personnel can monitor critical operational and maintenance data from a central control station that can be located far away from the production facility. Process data can be monitored to determine system anomalies that may indicate a need for preventive maintenance or an impending failure.

Adjustments made through the communications network can reduce costs by minimizing the time traveling to the location where the motor controls are located. When faults do occur, real time fault data can assist maintenance in troubleshooting and planning repair resources. Remote reset signals can be given to tripped devices without the need for manual intervention by maintenance personnel.

Average Line Current

Provides the average of the three phase RMS line currents in amps, accurate to within 2%. Current data can be used to indicate a need for maintenance. Increased currents in a fixed load application can indicate a reduction in system efficiencies and performance, signifying system maintenance is due.

Average Pole Current

Provides the average of the three phase RMS pole currents in amps, accurate to within 2%. The pole current is the current through the soft starter. The line and pole current will be identical in in-line applications, and will differ in inside-the-delta applications.

Average Line Current as a % FLA

Provides the average RMS line current as a percentage of the S611 FLA setting.

Three-Phase Line Currents

Provides three RMS phase line currents in amps, accurate to within 2%. Imbalances or changes in the relative phase current to one another can indicate anomalies in the motor or electrical distribution system.

Three-Phase Pole Currents

Provides three RMS phase pole currents in amps, accurate to within 2%. The pole current is the current through the soft starter. The line and pole current will be identical in in-line applications.

Three-Phase Line Voltages

Provides the individual RMS three phase line voltages. Imbalances or changes in the relative phase voltage to one another can indicate anomalies in the motor or electrical distribution system. Voltage can be used to monitor electrical distribution system performance. Warnings, alarms and system actions to low or high voltage conditions can be implemented.

Percent Thermal Memory

Provides the real time calculated thermal memory value. The S611 calculates thermal memory value. A 100% value represents the maximum safe temperature of the motor. When the thermal memory value reaches 100%, an overload trip will occur, removing power to the motor.

The thermal memory value can be of great use in determining an impending overload trip Condition. Alarms can be implemented in the process monitoring system warning of an Impending trip before a trip occurs, halting the process. Costly system downtime can be avoided.

Pole Temperature

Increases in pole temperature are caused by increases in ambient temperature, start/stop times and start duty cycles. Changes in pole temperatures represent a change in system operating conditions. Identifying unexpected operating conditions or changes can prompt maintenance and aid in process evaluation activities.

Power Monitoring

S611 can monitor power and it can be displayed on the UI.

Start Count

Number of starts are stored in the device and can be displayed using field bus.

Diagnostics**Fault Queue**

Current fault and a fault queue containing the last nine system faults can be read through the UI or communications network. Fault identification can minimize troubleshooting time and cost and prevent arc flash incidents. The fault queue can be remotely accessed through a communications network to assist in planning maintenance resources. 30 different faults can be identified by the S611.

Control Status

The S611 provides data that represents system conditions that can be read through the UI or the communications network. This data identifies the status of the system and the control commands the system is requesting of the S611. This can be used for advanced Troubleshooting and system integration activities.

Field Serviceability

In the case of maintenance, the S611 provides easy access and replacement of key components including control board and internal bypass contactors—significantly increasing its service life. If a component ever needs to be replaced, this straightforward operation can be completed by an end-user without the need to call in an outside service technician or engineer. These components are stocked and available for order and quick fulfillment—ensuring your operation continues with minimal downtime.

Operation

Instructional Leaflets

- Instruction Manual: MN03902011E
- Quick Start Guide: MN03901003E

Starting and Stopping Modes

The S611 has a variety of starting and stopping methods to provide superior performance in the most demanding applications. The motor can be started in either Voltage Ramp Start or Current Limit Start mode. Kick Start and Soft Stop are available within both starting modes.

Voltage Ramp Start

Provides a voltage ramp to the motor resulting in a constant torque increase. The most commonly used form of soft start, this start mode allows you to set the initial torque value and the duration of the ramp to full voltage conditions. Bypass contactors close after ramp time.

- Adjustable initial torque 0–85% of locked rotor torque
- Adjustable start ramp time 0.5–180 seconds (can be extended with factory modification)

Starting Characteristics—Ramp Start

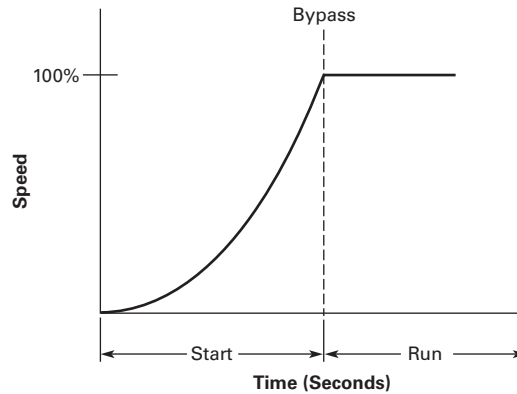
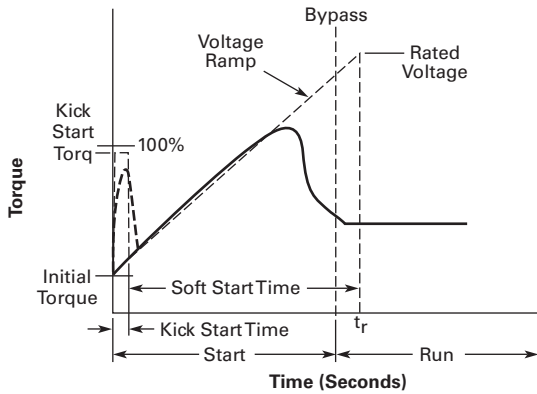

1

Current Limit Start

Limits the maximum current available to the motor during the start phase. This mode of soft starting is used when it becomes necessary to limit the maximum starting current due to long start times or to protect the motor. This start

mode allows you to set the maximum starting current as a percentage of locked rotor current and the duration of the current limit. Bypass contactors close after current limit time.

- Maximum current of 0–85% locked rotor current
- Adjustable start ramp time 0.5–180 seconds (can be extended with factory modification)

Starting Characteristics—Current Limit Start

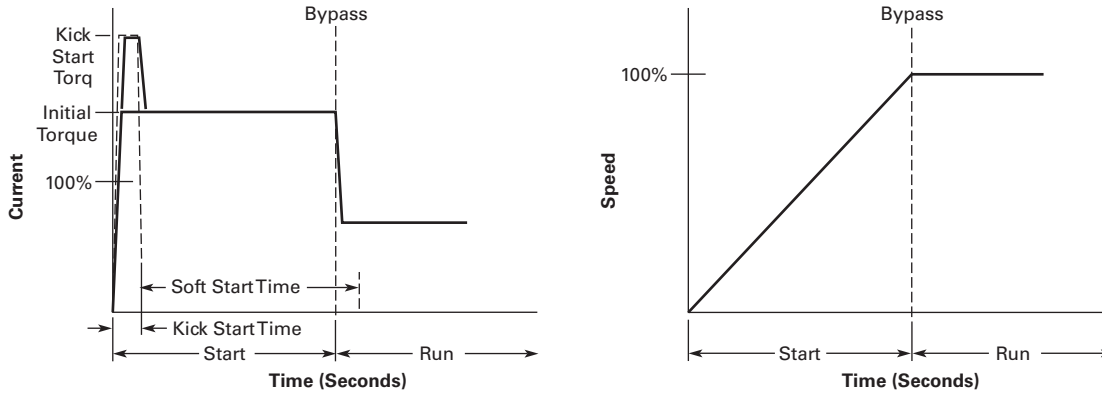

Kick Start

Selectable feature in both Voltage Ramp Start and Current Limit Start modes. Provides a current and torque “kick” for 0 to 2.0 seconds. This provides greater initial current to develop additional torque to breakaway a high friction load.

- 0–85% of locked rotor torque
- 0–2.0 seconds duration

Starting Characteristics—Kick Start

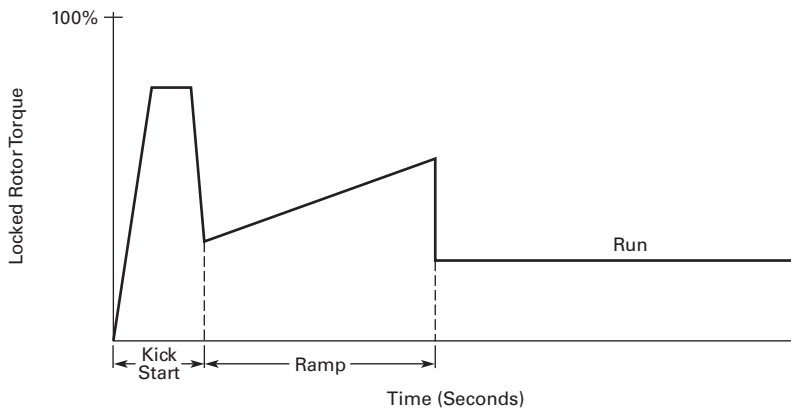

Soft Stop

Allows for a controlled stopping of a load. Used when a stop-time that is greater than the coast-to-stop time is desired. Often used with high friction loads where a sudden stop may cause system or load damage.

- Stop time = 0–60 seconds

Starting Characteristics—Soft Stop

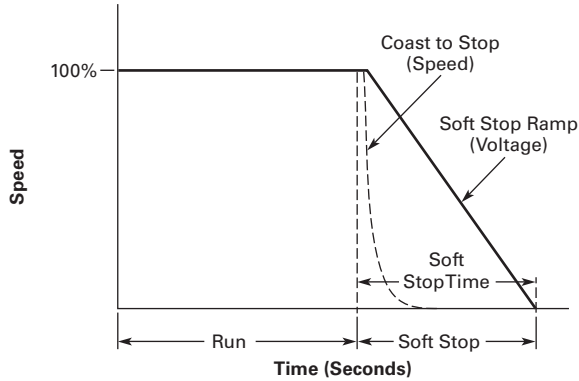

Pump Control Option

This option is intended to reduce the potential for water hammer in a centrifugal pump system by using a starting and stopping algorithm developed for pump control. Upon a start command, the speed of the motor is

increased, under the control of the S611 soft starter microprocessor, to achieve a gentle start. After the speed has reached its nominal value, the bypass contactors close and the pump operates as with any other starter.

Upon a stop command, the bypass contactors are opened and the motor speed is decreased in a tapered manner, to gradually slow the flow until the motor is brought to a stop.

Pump Control Option

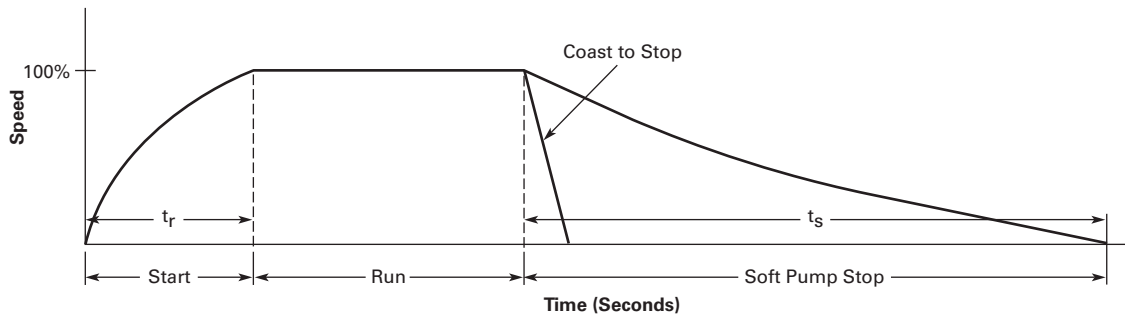

1

Edge and Level Sensing Control

Edge or Level Sensing is selected with the Start Control parameter in the Advanced Configuration Menu. Factory default is Level Sensing.

Edge Sensing

Edge sensing requires 120 Vac power be momentarily applied to the Start terminal (with the Permissive terminal 120 Vac) to initiate a start under all conditions. After a stop or fault occurs, the 120 Vac must be reapplied to the start terminal before another start can occur. This control configuration should be used when restarting of the motor after a fault or stop must be supervised manually or as a part of a control scheme. The cycling of 120 Vac power to the Permissive terminal before starting is required regardless of the position of the auto reset parameter.

Level Sensing

Level sensing will enable a motor to restart after a fault is cleared without cycling 120 V AC to the Permissive terminal as long as:

- Permissive terminal is supplied with 120 Vac
- The auto reset parameter is set to enabled
- All faults have cleared or have been reset

This control configuration should be used where it is desirable to restart a motor after a fault without additional manual or automatic control. An example of this condition would be on a remote pumping station where it is desirable to automatically restart a pump after a power outage without operator intervention.

Note: If the auto reset feature is used, CAUTION must be exercised to assure that any restart occurs in a safe manner.

Catalog Number Selection

S611 Soft Starters

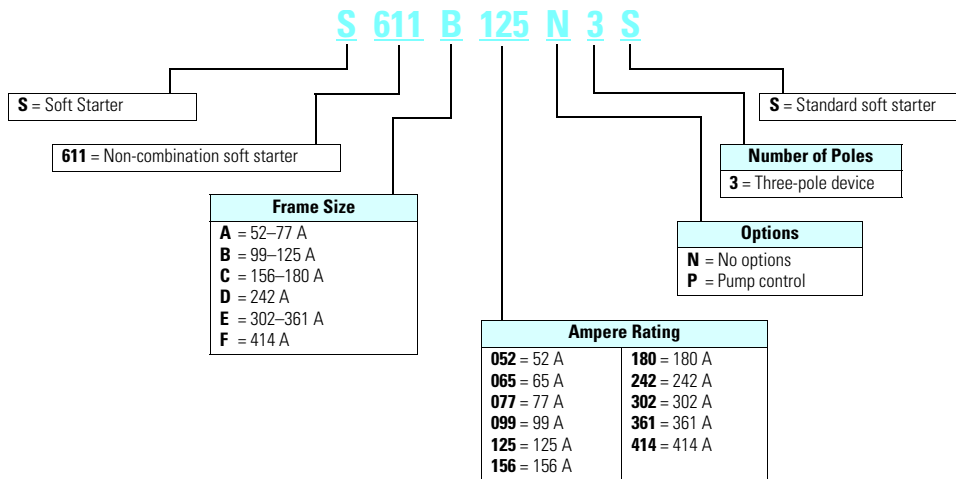

Product Selection

Motor applications and customer needs come in many different varieties. With the standard and severe duty rating tables, we have attempted to provide

guidelines on what the soft starter is capable of. If the application falls under these categories, you can use these charts. For other applications, or when a question arises,

consult with your local Eaton Representative or call the Eaton Technical Resource Center.

Pump Control Option

For pump control option, change the **8th** digit in the Catalog Number to **P**, as in S611XXX**P**3S.

Horsepower Ratings

Note: Always refer to motor plate FLA and ensure that the motor plate FLA is equal to or lower than the maximum current value in the tables.

S611



Standard Duty—300% Current for 15 Seconds, 115% Continuous

Rated Current (Amps)	Horsepower Rating				Catalog Number
	208 V	240 V	480 V	600 V	
52	15	15	40	50	S611A052N3S
65	20	20	50	60	S611A065N3S
77	25	25	60	75	S611A077N3S
99	30	30	75	100	S611B099N3S
125	40	40	100	125	S611B125N3S
156	50	60	125	150	S611C156N3S
180	60	60	150	150	S611C180N3S
242	75	75	200	250	S611D242N3S
302	100	100	250	300	S611E302N3S
361	125	150	300	350	S611E361N3S
414	150	150	350	450	S611F414N3S

Standard Duty Plus—350% FLA for 30 Seconds, 115% Continuous

Rated Current (Amps)	Horsepower Rating				Catalog Number
	208 V	240 V	480 V	600 V	
52	15	15	40	50	S611A052N3S
65	20	20	50	60	S611A065N3S
71	20	25	60	75	S611A077N3S
99	30	30	75	100	S611B099N3S
119	40	40	100	125	S611B125N3S
156	50	60	125	150	S611C156N3S
180	60	60	150	150	S611C180N3S
242	75	75	200	250	S611D242N3S
302	100	100	250	300	S611E302N3S
361	125	150	300	350	S611E361N3S
407	150	150	350	400	S611F414N3S

1.2

Reduced Voltage Motor Starters

Solid-State Starters

1

Note: Always refer to motor plate FLA and ensure that the motor plate FLA is equal to or lower than the maximum current value in the tables.

S611



Heavy Duty—500% FLA for 30 Seconds, 125% Continuous

Rated Current (Amps)	Horsepower Rating				Catalog Number
	208 V	240 V	480 V	600 V	
49	15	15	40	50	S611A052N3S
83	25	30	60	75	S611B099N3S
142	40	60	125	150	S611C156N3S
225	75	75	200	200	S611D242N3S
256	75	100	200	250	S611E361N3S
285	100	125	250	300	S611F414N3S

Severe Duty—600% FLA for 30 Seconds, 125% Continuous

Rated Current (Amps)	Horsepower Rating				Catalog Number
	208 V	240 V	480 V	600 V	
41	10	15	30	40	S611A052N3S
69	20	30	60	60	S611B099N3S
117	30	50	100	125	S611C180N3S
187	60	75	150	200	S611D242N3S
213	75	75	150	200	S611E361N3S
238	75	100	200	250	S611F414N3S

Accessories

Optional Accessory Kits

Description	S611 Current Rating	Accessory Kit Part Number
User interface remote mounting kit—3.28 ft (1 m)	52–414 A	S611-RMK-100
User interface remote mounting kit—6.56 ft (2 m)	52–414 A	S611-RMK-200
User interface remote mounting kit—9.84 ft (3 m)	52–414 A	S611-RMK-300
User interface communication cable—3.28 ft (1 m)	52–414 A	D77E-QPIP100
User interface communication cable—6.56 ft (2 m)	52–414 A	D77E-QPIP200
User interface communication cable—9.84 ft (3 m)	52–414 A	D77E-QPIP300
Lug kit—mechanical	52–77 A	S611-LUG-M01
	99–125 A	S611-LUG-M02
	156–242 A	S611-LUG-M03
	302–414 A	S611-LUG-M04

Communications

The S611 is equipped with native Modbus RTU communication capabilities and may be connected to a variety of networks, including DeviceNet, Modbus TCP, EtherNet/IP and PROFIBUS using the C441 series communication modules for easy integration into any PLC or DCS system.

The modules come standard with four inputs and two relay outputs. C441 communication modules can also be used independently for standalone I/O applications.



C441 Communication Card Options

Designed for use with soft starters ...



Protocol	Catalog Number	Input Signal Type	S611	General Purpose I/O ①	Mounting Options
Modbus RTU	C441NS	120 Vac	■	■	Standalone—DIN rail/panel mount
	C441PS	24 Vdc	■	■	Standalone—DIN rail/panel mount
DeviceNet	C441KS	120 Vac	■	■	Standalone—DIN rail/panel mount
	C441LS	24 Vdc	■	■	Standalone—DIN rail/panel mount
PROFIBUS	C441SS	120 Vac	■	■	Standalone—DIN rail/panel mount
	C441QS	24 Vdc	■	■	Standalone—DIN rail/panel mount
Modbus TCP, EtherNet/IP	C441U	120 Vac	■	■	Standalone—DIN rail/panel mount
	C441V	24 Vdc	■	■	Standalone—DIN rail/panel mount

Note: Refer to Volume 5—Motor Control and Protection, CA08100006E, tab 5.4 for additional details and BR042002EN brochure for C441 communication module accessories for overload relays and soft starters.

Recommended Power Supply	Catalog Number
85–264 Vac single-phase input, 24 Vdc output	PSG240E24RM
360–575 Vac three-phase input, 24 Vdc output	PSG240F24RM

Replacement Parts

S611 Replacement Components

Description	Part Number
User interface	S611-KEYPAD
User interface communication cable—0.25 m (0.82 ft)	D77E-QPIP25
Control board assembly—52 A standard	S611-PCB-052S
Control board assembly—65 A standard	S611-PCB-065S
Control board assembly—77 A standard	S611-PCB-077S
Control board assembly—99 A standard	S611-PCB-099S
Control board assembly—125 A standard	S611-PCB-125S
Control board assembly—156 A standard	S611-PCB-156S
Control board assembly—180 A standard	S611-PCB-180S
Control board assembly—242 A standard	S611-PCB-242S
Control board assembly—302 A standard	S611-PCB-302S
Control board assembly—361 A standard	S611-PCB-361S
Control board assembly—414 A standard	S611-PCB-414S
Control board assembly—52 A pump	S611-PCB-052P
Control board assembly—65 A pump	S611-PCB-065P

Description	Part Number
Control board assembly—77 A pump	S611-PCB-077P
Control board assembly—99 A pump	S611-PCB-099P
Control board assembly—125 A pump	S611-PCB-125P
Control board assembly—156 A pump	S611-PCB-156P
Control board assembly—180 A pump	S611-PCB-180P
Control board assembly—242 A pump	S611-PCB-242P
Control board assembly—302 A pump	S611-PCB-302P
Control board assembly—361 A pump	S611-PCB-361P
Control board assembly—414 A pump	S611-PCB-414P
Frame A/B CT	S611-CT-AB
Frame C/D CT	S611-CT-CD
Frame E/F CT	S611-CT-EF
Contact assembly—52–180 A	C25DNY172
Contact assembly—242–414 A	C25DNY173

Note

① C441 standalone communication modules can be used as general purpose I/O. This allows a customer to monitor the status of any non-communicating product over the selected protocol by wiring fault or auxiliary contacts from that product to the C441 communication module on-board I/O.

Technical Data and Specifications

Soft Starters—S611

Description		S611 Soft Starter (Partial Catalog Number)			
		S611A052...	S611A065...	S611A072...	S611B099...
Max. current capacity	A	52	65	77	99
FLA range	A	26–52	32.5–65	38.5–77	48–99
Dimensions					
Width	inch (mm)	11.58 (294)	11.58 (294)	11.58 (294)	11.58 (294)
Height	inch (mm)	19.45 (494)	19.45 (494)	19.45 (494)	19.45 (494)
Depth	inch (mm)	7.46 (189)	7.46 (189)	7.46 (189)	7.46 (189)
Weight	lb (kg)	24 (11)	24 (11)	24 (11)	24 (11)
General Information					
Bypass mechanical lifespan		10M	10M	10M	10M
Insulating voltage	V	660	660	660	660
Ramp time range	Seconds	0.5–180	0.5–180	0.5–180	0.5–180
Vibration resistance—non-operating	g	3 g up to 242 A units, 2 g on 302 A to 414 A units	3 g up to 242 A units, 2 g on 302 A to 414 A units	3 g up to 242 A units, 2 g on 302 A to 414 A units	3 g up to 242 A units, 2 g on 302 A to 414 A units
Vibration resistance—operating	g	1	1	1	1
Shock resistance	g	15 g up to 242 A units, 5 g on 302 A to 414 A units	15 g up to 242 A units, 5 g on 302 A to 414 A units	15 g up to 242 A units, 5 g on 302 A to 414 A units	15 g up to 242 A units, 5 g on 302 A to 414 A units
Electrical Information					
Operating voltage	V	130–600	130–600	130–600	130–600
Operating frequency	Hertz	47–63	47–63	47–63	47–63
Overload setting (frame)	% FLA	50–100	50–100	50–100	50–100
Trip class		5, 10, 20, 30	5, 10, 20, 30	5, 10, 20, 30	5, 10, 20, 30
Cabling Capacity (IEC 947)					
Number of conductors		1	1	1	1
Wire sizes	AWG	14–2/0	14–2/0	14–2/0	14–2/0
Type of connectors		Lug	Lug	Lug	Lug
Control Wiring					
Wire sizes	AWG	22–12	22–12	22–12	22–12
Number of conductors		2 (or one 12–14 AWG)	2 (or one 12–14 AWG)	2 (or one 12–14 AWG)	2 (or one 12–14 AWG)
Torque requirements	lb-in	3.5	3.5	3.5	3.5
Maximum size	AWG	12	12	12	12
Control Power Requirements					
Voltage range (120 V ±10%)	V	108–132	108–132	108–132	108–132
Steady state current	A	0.375	0.375	0.375	0.375
Inrush current	A	0.5	0.5	0.5	0.5
Ripple	%	1	1	1	1
Relays (1) Class A and C					
Voltage AC—maximum	V	120	120	120	120
Voltage DC—maximum	V	24	24	24	24
Amps—maximum	A	3	3	3	3
Environment					
Temperature—operating	°C	–20 ° to 50 °C	–20 ° to 50 °C	–20 ° to 50 °C	–20 ° to 50 °C
Temperature—storage	°C	–40 ° to 85 °C	–40 ° to 85 °C	–40 ° to 85 °C	–40 ° to 85 °C
Altitude	Meters	<2000 m, derate 0.5% per 100 m >2000 m	<2000 m, derate 0.5% per 100 m >2000 m	<2000 m, derate 0.5% per 100 m >2000 m	<2000 m, derate 0.5% per 100 m >2000 m
Humidity	%	<95% noncondensing	<95% noncondensing	<95% noncondensing	<95% noncondensing
Operating position		Vertical, line side up	Vertical, line side up	Vertical, line side up	Vertical, line side up
Pollution degree IEC947-1		3	3	3	3
Impulse withstand voltage IEC947-4-1	V	6000	6000	6000	6000

Soft Starters—S611, continued

Description		S611 Soft Starter (Partial Catalog Number)			
		S611B125...	S611C156...	S611C180...	S611D242...
Max. current capacity	A	125	156	180	242
FLA range	A	62.5–125	78–156	90–180	120–242
Dimensions					
Width	inch (mm)	11.58 (294)	11.58 (294)	11.58 (294)	11.58 (294)
Height	inch (mm)	19.45 (494)	20.83 (529)	20.83 (529)	20.83 (529)
Depth	inch (mm)	7.46 (189)	8.37 (213)	8.37 (213)	8.37 (213)
Weight	lb (kg)	24 (11)	33 (15)	33 (15)	38 (17)
General Information					
Bypass mechanical lifespan		10M	10M	10M	10M
Insulating voltage	V	660	660	660	660
Ramp time range	Seconds	0.5–180	0.5–180	0.5–180	0.5–180
Vibration resistance—non-operating	g	3 g up to 242 A units, 2 g on 302 A to 414 A units	3 g up to 242 A units, 2 g on 302 A to 414 A units	3 g up to 242 A units, 2 g on 302 A to 414 A units	3 g up to 242 A units, 2 g on 302 A to 414 A units
Vibration resistance—operating	g	1	1	1	1
Shock resistance	g	15 g up to 242 A units, 5 g on 302 A to 414 A units	15 g up to 242 A units, 5 g on 302 A to 414 A units	15 g up to 242 A units, 5 g on 302 A to 414 A units	15 g up to 242 A units, 5 g on 302 A to 414 A units
Electrical Information					
Operating voltage	V	130–600	130–600	130–600	130–600
Operating frequency	Hertz	47–63	47–63	47–63	47–63
Overload setting (frame)	% FLA	50–100	50–100	50–100	50–100
Trip class		5, 10, 20, 30	5, 10, 20, 30	5, 10, 20, 30	5, 10, 20, 30
Cabling Capacity (IEC 947)					
Number of conductors		1	1	1	1
Wire sizes	AWG	2–600 kcmil	2–600 kcmil	2–600 kcmil	2–600 kcmil
Type of connectors		Lug	Lug	Lug	Lug
Control Wiring					
Wire sizes	AWG	22–12	22–12	22–12	22–12
Number of conductors		2 (or one 12–14 AWG)	2 (or one 12–14 AWG)	2 (or one 12–14 AWG)	2 (or one 12–14 AWG)
Torque requirements	lb-in	3.5	3.5	3.5	3.5
Maximum size	AWG	12	12	12	12
Control Power Requirements					
Voltage range (120 V ±10%)	V	108–132	108–132	108–132	108–132
Steady state current	A	0.375	0.375	0.375	0.375
Inrush current	A	0.5	0.5	0.5	0.5
Ripple	%	1	1	1	1
Relays (1) Class A and C					
Voltage AC—maximum	V	120	120	120	120
Voltage DC—maximum	V	24	24	24	24
Amps—maximum	A	3	3	3	3
Environment					
Temperature—operating	°C	–20 ° to 50 °C	–20 ° to 50 °C	–20 ° to 50 °C	–20 ° to 50 °C
Temperature—storage	°C	–40 ° to 85 °C	–40 ° to 85 °C	–40 ° to 85 °C	–40 ° to 85 °C
Altitude	Meters	<2000 m, derate 0.5% per 100 m >2000 m	<2000 m, derate 0.5% per 100 m >2000 m	<2000 m, derate 0.5% per 100 m >2000 m	<2000 m, derate 0.5% per 100 m >2000 m
Humidity	%	<95% noncondensing	<95% noncondensing	<95% noncondensing	<95% noncondensing
Operating position		Vertical, line side up	Vertical, line side up	Vertical, line side up	Vertical, line side up
Pollution degree IEC947-1		3	3	3	3
Impulse withstand voltage IEC947-4-1	V	6000	6000	6000	6000

Soft Starters—S611, continued

Description		S611 Soft Starter (Partial Catalog Number)		
		S611E302...	S611E361...	S611F414...
Max. current capacity	A	302	361	414
FLA range	A	151–302	180.5–361	207–414
Dimensions				
Width	inch (mm)	17.56 (446)	17.56 (446)	17.56 (446)
Height	inch (mm)	31.15 (791)	31.15 (791)	31.15 (791)
Depth	inch (mm)	9.54 (242)	9.54 (242)	9.54 (242)
Weight	lb (kg)	86 (39)	86 (39)	102 (46)
General Information				
Bypass mechanical lifespan		10M	10M	10M
Insulating voltage	V	660	660	660
Ramp time range	Seconds	0.5–180	0.5–180	0.5–180
Vibration resistance—non-operating	g	3 g up to 242 A units, 2 g on 302 A to 414 A units	3 g up to 242 A units, 2 g on 302 A to 414 A units	3 g up to 242 A units, 2 g on 302 A to 414 A units
Vibration resistance—operating	g	1	1	1
Shock resistance	g	15 g up to 242 A units, 5 g on 302 A to 414 A units	15 g up to 242 A units, 5 g on 302 A to 414 A units	15 g up to 24 A units, 5 g on 302 A to 414 A units
Electrical Information				
Operating voltage	V	130–600	130–600	130–600
Operating frequency	Hertz	47–63	47–63	47–63
Overload setting (frame)	% FLA	50–100	50–100	50–100
Trip class		5, 10, 20, 30	5, 10, 20, 30	5, 10, 20, 30
Cabling Capacity (IEC 947)				
Number of conductors		2	2	2
Wire sizes	AWG	2–600 kcmil	2–600 kcmil	2–600 kcmil
Type of connectors		Lug	Lug	Lug
Control Wiring				
Wire sizes	AWG	22–12	22–12	22–12
Number of conductors		2 (or one 12–14 AWG)	2 (or one 12–14 AWG)	2 (or one 12–14 AWG)
Torque requirements	lb-in	3.5	3.5	3.5
Maximum size	AWG	12	12	12
Control Power Requirements				
Voltage range (120 V ±10%)	V	108–132	108–132	108–132
Steady state current	A	0.75	0.75	0.75
Inrush current	A	1	1	1
Ripple	%	1	1	1
Relays (1) Class A and C				
Voltage AC—maximum	V	120	120	120
Voltage DC—maximum	V	24	24	24
Amps—maximum	A	3	3	3
Environment				
Temperature—operating	°C	–20 ° to 50 °C	–20 ° to 50 °C	–20 ° to 50 °C
Temperature—storage	°C	–40 ° to 85 °C	–40 ° to 85 °C	–40 ° to 85 °C
Altitude	Meters	<2000 m, derate 0.5% per 100 m >2000 m	<2000 m, derate 0.5% per 100 m >2000 m	<2000 m, derate 0.5% per 100 m >2000 m
Humidity	%	<95% noncondensing	<95% noncondensing	<95% noncondensing
Operating position		Vertical, line side up	Vertical, line side up	Vertical, line side up
Pollution degree IEC947-1		3	3	3
Impulse withstand voltage IEC947-4-1	V	6000	6000	6000

Dimensions

Approximate Dimensions in inches (mm)

S611A..., S611B...

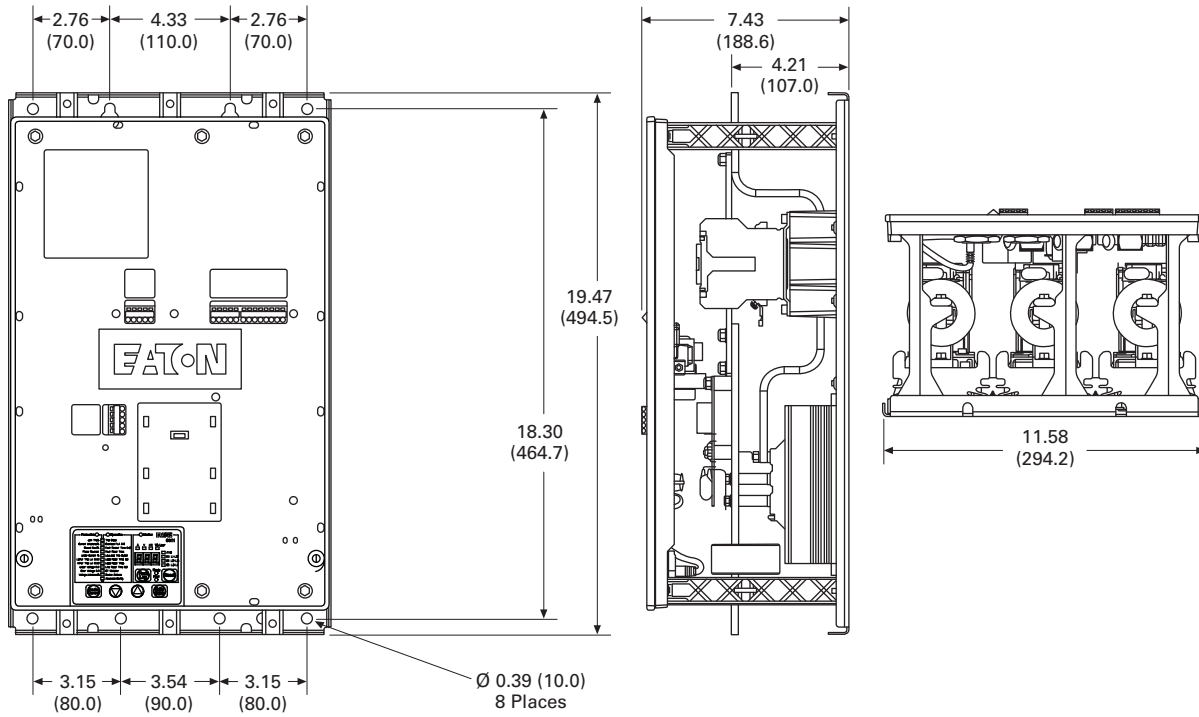

S611C..., S611D...

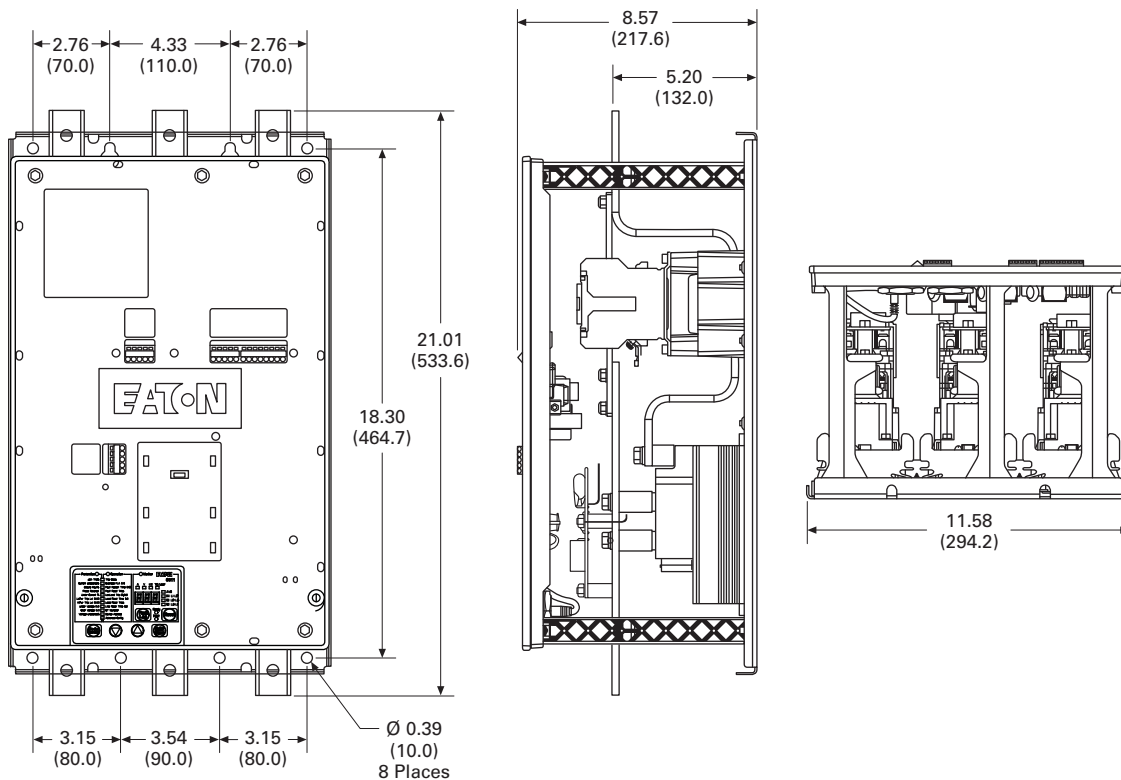

1.2

Reduced Voltage Motor Starters

Solid-State Starters

1

Approximate Dimensions in inches (mm)

S611E..., S611F...

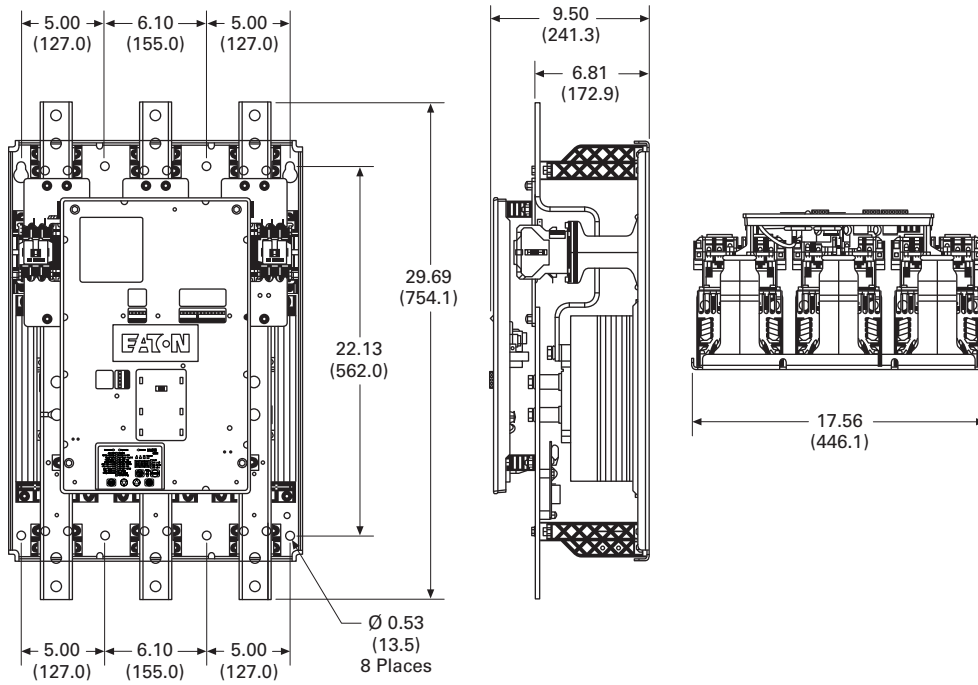

Torque Limiters



TL480N25

Contents

Description

Type S611 Soft Starters
Torque Limiters
Product Selection
Type S711 Soft Starters
Type S801+ Soft Starters
Type S811+ Soft Starters with DIM

Page

V6-T1-43
V6-T1-60
V6-T1-61
V6-T1-81
V6-T1-97

Torque Limiters

Product Description

The TL device line of starting torque limiters is designed for the soft start of three-phase or single-phase motors, i.e., it allows smoother starting of all AC induction motors, thus decreasing shock and vibration problems encountered during across-the-line starts. The device is ramp-up time/torque adjustable from 0.5 to 5 seconds/0 to 85% of nominal starting torque.

Features and Benefits

Features

- Rated operational voltage up to 600 Vac
- Adjustable ramp times (0.5–5 seconds)
- Adjustable initial torque control (0–85%)
- Unlimited number of START/STOP operations per hour
- IP20 finger protection

Benefits

- Reduced wear on belts, gears, chains, clutches, shafts and bearings
- Compact design allows easy installation and smaller enclosures
- Less shock to product on conveyor lines and material handling gear

Standards and Certifications

- IEC 947 compliant
- EN 60947-4-2
- CE marked
- CSA certified
- UL listed



Product Selection

Torque Limiters

Max. Current	Line Voltage	kW Rating (50 Hz)				Horsepower Rating						Catalog Number			
		110/120 V	230 V	380–400 V	440 V	110/120 V	200 V	230 V	460 V	575 V					
						—	1.0 SF	1.15 SF	1.0 SF	1.15 SF	1.0 SF	1.15 SF	1.0 SF	1.15 SF	
Single-Phase Motor – 115 V Versions															
15	110–120	0.5	N/A	N/A	N/A	3/4	N/A	N/A	N/A	N/A	N/A	N/A	N/A	N/A	TL115N15
25	110–120	1.5	N/A	N/A	N/A	2	N/A	N/A	N/A	N/A	N/A	N/A	N/A	N/A	TL115N25
Three-Phase Motor															
15	208–480	N/A	4.0	5.5	7.5	N/A	3	3	3	3	10	7-1/2	N/A	N/A	TL480N15
	500–600	N/A	N/A	N/A	N/A	N/A	N/A	N/A	N/A	N/A	N/A	N/A	10	10	TL600N15
25	208–480	N/A	7.5	12.5	12.5	N/A	5	5	7-1/2	5	15	15	N/A	N/A	TL480N25
	500–600	N/A	N/A	N/A	N/A	N/A	N/A	N/A	N/A	N/A	N/A	N/A	20	20	TL600N25
Single-Phase Motor															
15	208–240	N/A	2.2	N/A	N/A	N/A	2	2	3	3	N/A	N/A	N/A	N/A	TL480N15
	380–480	N/A	N/A	N/A	N/A	N/A	N/A	N/A	N/A	N/A	5	5	N/A	N/A	TL480N15
25	208–240	N/A	4.0	7.5	N/A	N/A	3	3	5	5	N/A	N/A	N/A	N/A	TL480N25
	380–480	N/A	N/A	7.5	N/A	N/A	N/A	N/A	N/A	N/A	10	10	N/A	N/A	TL480N25

S711 Soft Starters



Contents

<i>Description</i>	<i>Page</i>
Type S611 Soft Starters	V6-T1-43
Torque Limiters	V6-T1-59
Type S711 Soft Starters	
Communications	V6-T1-62
Operation	V6-T1-62
Timed Voltage Ramp	V6-T1-62
Features and Benefits	V6-T1-64
Catalog Number Selection	V6-T1-64
Standards and Certifications	V6-T1-68
Product Selection	V6-T1-69
Accessories	V6-T1-73
Technical Data and Specifications	V6-T1-74
Wiring Diagrams	V6-T1-75
Dimensions	V6-T1-76
Type S801+ Soft Starters	V6-T1-81
Type S811+ Soft Starters with DIM	V6-T1-97

S711 Soft Starters

Product Description

Eaton's S711 brings simplicity to advanced functionality with its enhanced communications, metering, monitoring and diagnostic capabilities via keypad or mobile device.

Eaton's S711 line of reduced voltage soft starters is multi-functional, easy to commission and easy to use. Designed to control the acceleration and deceleration of three-phase motors up to 575 V, the line is available from 12 A to 560 A.

The S711 is designed to be a complete package, combining the silicon controlled rectifiers (SCRs), bypass contactor and overload in one compact unit.

Application Description

Designed to control the acceleration and deceleration of three-phase motors, the S711 soft starter uses SCRs to control the voltage to soft start and soft stop the motor. After the motor is started, internal run bypass contactors close, resulting in the motor running directly across-the-line. The built-in solid-state overload protects the motor from overload conditions with sophisticated algorithms that model true motor heating, resulting in better motor protection and fewer nuisance trips. Advanced protective and diagnostic features reduce downtime.

A timed voltage start or constant current start is available. Kickstart is available in conjunction with current ramp or constant current starting. The soft stop option allows for a ramp stop time that is longer than the coast to stop time. The onboard pump control option provides a smooth transition for starting and stopping a motor and eliminating the "water-hammer" effect that can damage pipes, valves and pumps.

The S711 offers an impressive array of advanced protective features. Not only are the protective features selectable, but many offer variable settings and adjustable time delays to ride through system discrepancies. Protective features may also be set to Warning status to avoid nuisance trips.

The S711 has an easy-to-use keypad that allows the user to configure the device and to read system parameters and monitor system values. The keypad includes an LCD display and clearly marked keys to scroll through the various menus. The keypad allows the user to modify control parameters, enable or disable protections, set communication variables, monitor system parameters such as line voltages and currents, and access the fault queue.

The keypad can be removed from the S711 and be remote mounted. The keypad can be mounted directly to a door and utilizes an o-ring to protect the RJ45 port to an IP65 rating, enabling users to safely configure, commission, monitor and troubleshoot the system at the electrical panel without opening the enclosure door. This will help eliminate the possibility of an arc flash incident.



Keypad

1

Communications

The S711 is equipped with native Modbus RTU communication capabilities and may be connected to a variety of networks, including Modbus TCP, EtherNet/IP and PROFINET for easy integration into any PLC or DCS system.

The modules come standard with four inputs and two relay outputs. C441 communication modules can also be used independently for standalone I/O applications.



S711 Communication Card Options

Designed for use with S711



Protocol	Catalog Number	Mounting Options
EtherNet/IP	S711-NET-ETHERNET	Inside option card holder built into S711
Modbus TCP	S711-NET-MOVBUSTCP	Inside option card holder built into S711
PROFINET	S711-NET-PROFINET	Inside option card holder built into S711

Operation

Starting and Stopping Modes

The S711 has a variety of starting and stopping methods to provide superior performance in the most demanding applications. The motor can be started in either timed voltage ramp start or constant current start mode. Kickstart and soft stop are available within both starting modes. The user has the option to configure two independent start ramp profiles to accommodate variations in starting requirements.

Timed Voltage Ramp

Provides a voltage ramp to the motor resulting in a constant torque increase. The most commonly used form of soft start, this start mode allows you to set the initial current value and the duration of the ramp to full voltage conditions. Bypass contactors close after ramp time.

- Adjustable ramp time 1.0–180 seconds

Starting Characteristics—Timed Voltage Ramp

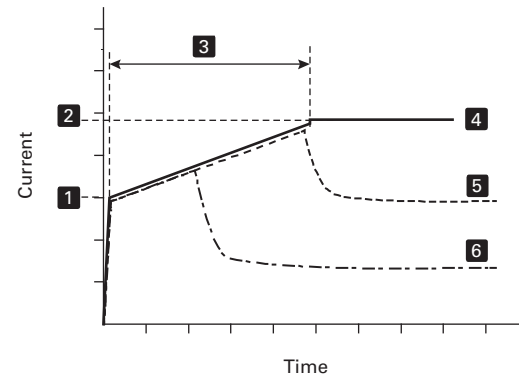

- ① Initial current (parameter P3.3)
- ② Current limit (parameter P3.4)
- ③ Start ramp time (parameter P3.2)
- ④ Full voltage
- ⑤ Motor 1 current
- ⑥ Motor 2 current

Constant Current Start

Limits the maximum current available to the motor during the start phase. This mode of soft starting is used when it becomes necessary to limit the maximum starting current due to long start times or to protect the motor. Bypass contactors close after current limit time.

- Adjustable ramp time 1.0–180 seconds

Starting Characteristics—Constant Current

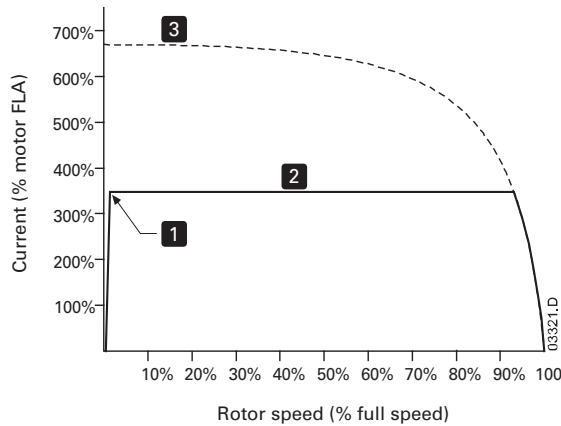

- ① Initial current (parameter P3.3)
- ② Current limit (parameter P3.4)
- ③ Full voltage current

Timed Voltage Ramp Soft Stop

Allows for a controlled stopping of a load. Used when a stop-time that is greater than the coast-to-stop

time is desired. Often used with high friction loads where a sudden stop may cause system or load damage.

- Stop time = 0–4 minutes

Starting Characteristics—Timed Voltage Ramp Soft Stop

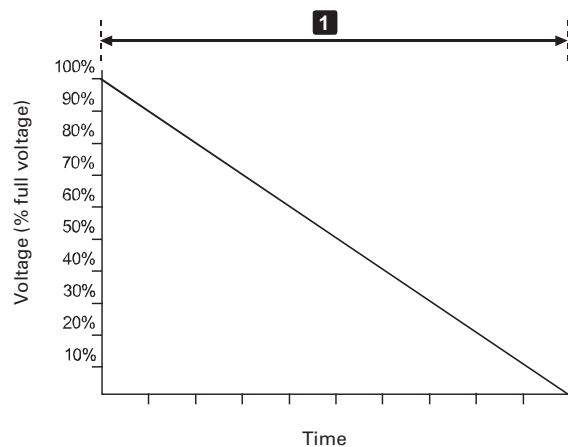

- ① Stop Time (parameter P3.10)

Kickstart

Selectable feature in both current ramp and constant current start modes. Provides a current and torque “kick” for 0 to 2.0 seconds.

This provides greater initial current to develop additional torque to breakaway a high friction load.

- 100–500% of FLA
- 0–2.0 seconds duration

Starting Characteristics—Kickstart

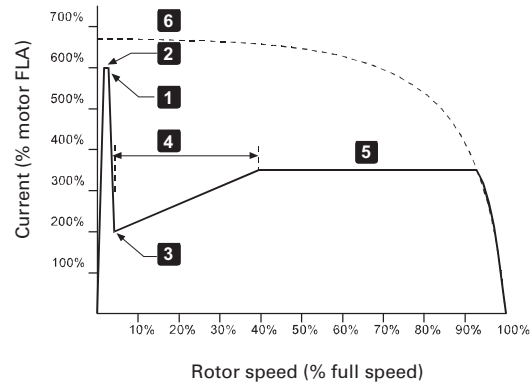

- ① Kickstart level (parameter P3.7)
- ② Kickstart time (parameter P3.6)
- ③ Initial current (parameter P3.3)
- ④ Start ramp time (parameter P3.2)
- ⑤ Current limit (parameter P3.4)
- ⑥ Full voltage current

Features and Benefits

- Communication capabilities with various protocols, including Bluetooth LE for use with the dedicated S711 Connect app
- Keypad provides an intuitive, easy-to-use human interface with powerful configuration capabilities to maximize system performance
- Door- or device-mounted keypad enables users to safely configure, commission, monitor and troubleshoot the system at the electrical panel without opening the enclosure door, eliminating the possibility of an arc flash incident
- System operating parameters can be monitored enterprise-wide through a communications network. Increase uptime by providing data for process management and preventive diagnostics
- Run internal bypass mode greatly reduces internal heating created by the greater power dissipation in the SCRs. Bypass contactor directly connects the motor to the line and improves system efficiency by reducing internal power losses
- Internal solid-state overload protection provides accurate current measurement and trip settings. Sophisticated algorithms solve a series of differential equations that model true motor heating and cooling, resulting in superior motor overload protection while minimizing nuisance trips. Advanced selectable protective features safeguard the motor and system against a variety of system faults
- Internal run bypass contactors and overload protection eliminate the need for additional devices, reducing enclosure sizes, minimizing installation and wiring time, and reducing overall assembly size and cost
- Wide range of overload FLA settings (0–160% of rated current) and a selectable trip class (5–30) offers users the flexibility to fine tune the starter to match specific application requirements
- Variable ramp times and torque control settings provide unlimited starting configurations, allowing for maximum application flexibility
- Kickstart feature enables soft starting of high friction loads
- Soft stop control for applications where an abrupt stop of the load is not acceptable
- Built-in applications for pumps, compressors, conveyors, fans and more allow for easy commissioning and customization
- Six SCRs control all three motor phases, providing smooth acceleration and deceleration performance
- Soft acceleration and deceleration reduces wear on belts, gears, chains, clutches, shafts and bearings
- Reduce the peak inrush current's stress on the power system
- Manage peak starting torque to diminish mechanical system wear and damage
- 24 Vdc or 120/240 Vac control voltage options for each unit offer flexibility
- Removable, lockable control terminal block reduces maintenance costs. Also provides the opportunity for OEMs to reduce assembly and test costs by utilizing pre-assembled wire harnesses

Motor Wiring Configuration User Selectable Inline or Inside-the-Delta

Mains Motor Wiring Configuration is accomplished by simply selecting the required configuration from a menu. This feature allows adaptability from one configuration to another without any additional programming operations and reduces inventory levels by not having to stock both configurations.

Modbus RTU and Bluetooth LE Native Communications Protocols

Modbus RTU and Bluetooth LE communications are standard on all S711 units. This allows users to quickly configure the unit for network communications using either a common protocol or the S711 Connect app on a mobile device. Option cards are available for users who prefer to use EtherNet/IP, PROFINET or Modbus TCP protocols.

Programmable Control Terminal Block Functionality

Two programmable digital inputs and two programmable relay outputs enable the user to expand functionality with options such as a second start ramp profile, externally triggered trip or warning functions, secondary motor set and others, in addition to the normal start, stop, reset, and so on, functions.

Second Start Ramp Profile Capability

A second start ramp profile may be configured for the soft starter. This profile is independent of the primary profile and retains all the parameter options such as start time and initial torques. With a signal at a terminal programmed for this feature, the second profile may be selected by a pushbutton station or a network.

Alarm-No-Trip Functionality

Some applications require the ability to effectively disable most protections with the intent of enabling the RVSS unit to control a motor under the most severe operating conditions characterized by current or voltage imbalances, high or low value deviations, or other fault conditions. This function causes the S711 to ignore most fault trip conditions and continue operation of the application.

Keypad Cloning

For OEMs or other users that desire to load identical parameter settings into multiple RVSS units, the keypad may be used to extract and duplicate parameter settings from one RVSS and loaded into other units, saving time, effort, and reducing chances for errors while programming.

Protective Features

All protective features can be configured, enabled or disabled with the keypad or mobile device.

Motor Overload

The S711 includes electronic overload protection as standard. The overload meets applicable requirements for a motor overload protective device. The overload protects the motor from over heat conditions with the use of sophisticated algorithms that model true motor heating, resulting in superior motor protection and fewer nuisance trips.

The soft starter's motor overload protection constantly monitors the motor current. When an overload is detected, the starter will respond as determined by parameter P5.31 Motor Overload. The motor overload trip cannot be reset until the overload clears. The starter will be unable to attempt another start if there is insufficient overload capacity remaining. The Reset Overload feature can be used to override a motor overload, in the event of an emergency.

Short Circuit

The use of a short-circuit protective device in coordination with the S711 is required in branch motor circuits by most electrical codes. Short-circuit coordination ratings with both fuses and Eaton molded case circuit breakers are available providing customers with design flexibility. The S711 has short-circuit coordination ratings as an open component, an enclosed starter, and in a motor control center.

External E-Stop

Emergency Stop functionality may be triggered from an external source. Removal of the 24 Vdc signal from a terminal configured for E-Stop will initiate an E-Stop action. The External E-Stop option is useful in applications where it is desirable to accomplish a motor shutdown in the event that an external condition(s) exist that will damage system components and/or product flows or operations.

External Trip

External Trip functionality may be triggered from an external source. Removal of the 24 Vdc signal from a terminal configured for External Trip will initiate an External Trip action. The External Trip option is useful in applications where it is desirable to accomplish a motor stop in the event that an external condition(s) exist that will damage system components and/or product flows or operations.

Fault Warning Functionality

Selected protection parameters may be assigned to provide a Fault Warning instead of a Fault Trip with user adjustable set points. When a Fault Warning condition is detected, the fault condition is reported via the keypad, network connection, or an auxiliary relay configured for this function. The soft starter remains in operation. At such time the fault condition no longer exists, the Fault Warning message will be extinguished.

External Warning

The S711 will accept a Warning signal from an external source or device. In a fashion similar to the Fault Warning, the fault condition is reported via the keypad, network connection, or an auxiliary relay configured for this function. The soft starter remains in operation. At such time the fault condition no longer exists, the Fault Warning message will be extinguished.

Custom Fault/Warning Auxiliary Relays

Up to three fault and/or warning codes may be selected to operate an auxiliary relay configured to operate when any of these codes are detected. This option enables the user to provide external warnings or fault indications to increase monitoring effectiveness and to provide additional system control.

Motor Power

Motor Power can be not only be monitored, but trip levels can be adjusted to provide indications of system malfunctions or operating discrepancies. Both underpower and overpower thresholds can be set to provide Fault Warning or Fault Trip functions. Additionally, fault delays times may be set to up to 60 seconds.

Analog Input

An input control terminal may be configured to accept a 0–20 mA DC signal with range scaling. This feature enables the S711 to respond to an external device that may be monitoring a critical component or process and provides Fault Trip or Fault Warning capability to protect operating systems and processes.

Start Delay

Three start delay timers are available to enhance motor protection or to provide simple logic functions to coordinate motor control with other devices in the system. The timers will allow delays from 24 Vdc power up, receipt of a valid START command, or a delay in switch from one start ramp profile to another.

Jam

Excessive current and torque up to locked rotor levels can occur in a jam condition. The condition can result in stress and damage to the motor, load, mechanical system and the electrical distribution system. Jam protection prevents the stress and damage from a jam during normal run. After the motor is in bypass, a current greater than 300% FLA setting will cause the starter to trip on a jam fault.

Stall

Excessive current and torque up to locked rotor levels can occur in a stall condition. The condition can lead to an overload trip and result in stress and damage to the motor, load, mechanical system, and the electrical distribution system. Stall protection prevents stress and damage to a motor that has not come up to speed during the soft start time. The S811+ will trip to protect the system in the event that the motor did not get to the rated speed in the defined soft start period. A current greater than 200% FLA at the end of the soft start period will cause the starter to trip on a stall fault.

Pole Over Temperature

High ambient temperatures, extended ramp times and high duty cycle conditions may cause the S711 power pole conductors to reach a temperature that exceeds their thermal rating. The S711 is equipped with sensors that monitor the temperature of the power poles. Over temperature protection occurs if the power pole's thermal capacity is exceeded. The soft starter will trip in over temperature conditions, preventing device failure.

Each power pole temperature value can be monitored through the keypad or the communications network. This feature can be of use in determining an impending over temperature trip condition.

When using a communications network, alarms can be implemented in the process monitoring system warning of an impending trip before the trip occurs, halting the process.

Phase Current Imbalance

Phase current imbalance can cause a significant increase in the current drawn in the remaining two phases. Phase imbalance can lead to motor damage before an eventual overload trip. Phase imbalance can have multiple causes such as imbalance in the motor supply, phase loss on the input terminals, light load on the motor, SCR failure, etc. The S711 will detect current and phase imbalances and trip if any phase becomes imbalanced as compared to the average of the other two phases.

The phase current imbalance trip level is adjustable from 0% to 50% with an adjustable trip delay of 1 to 240 seconds.

Reset Mode

The S711 can be set up for automatic or manual reset on trip. The manual reset mode requires the operator to physically press the RESET button located on the soft starter.

The automatic reset mode allows the soft starter to be automatically reset as soon as the trip condition is no longer present. With the automatic reset mode, after the fault is no longer present, the motor will be restarted as soon as a valid start signal is present. The Auto Reset Count can be configured to set how many times the soft starter will auto reset, if it continues to trip. A delay can also be configured to delay when the soft starter will auto reset a trip.

Shorted SCR Detection

The S711 has built-in Shorted SCR Detection. The S711 selects whether the soft starter will allow two-phase control operation, if the soft starter is damaged on one phase. The soft starter will use two-phase control, allowing the motor to continue operation in critical applications.

Undercurrent

Undercurrent conditions can be a result of a loss of load or a failure in the mechanical system. The S711 has undercurrent protection that will trip if it falls beneath a configured percentage of the motor full load amperage. The low current protection can be programmed as a percent of motor FLA from 0% to 100%.

Overcurrent

Overcurrent conditions can be a result of a mechanical issue in the system. The S711 has overcurrent protection that will trip if it reaches a configured percentage of the motor full load amperage. Overcurrent protection can be programmed as a percent of motor FLA from 80% to 600%.

Undervoltage

Undervoltage conditions can result from disturbances in the electrical power distribution system. Low voltage conditions can cause a malfunction and damage to electrical equipment. The S711 has undervoltage protection to protect the device if an abnormal voltage surge occurs. The undervoltage range can be programmed as a trip point value with a delay and specified action.

Overvoltage

Overvoltage conditions can result from disturbances in the electrical power distribution system. Overvoltage conditions can cause malfunctions or failures of electrical equipment. The S711 has overvoltage protection to protect the device if an abnormal voltage surge occurs. The overvoltage range can be programmed as a trip point value with a delay and specified action.

Motor Protection*Excess Start Time*

Excess start time is the maximum time the soft starter will attempt to start the motor. Excess start time can cause an increase of heat generation or higher energy consumption, which is cause for a potential overload. If the motor does not transition to Run mode within the programmed limit, the S711 will trip.

The excess start time can be configured from 1 to 240 seconds with a customizable action.

Restart Delay

The S711 can be configured to force a delay between the end of a stop and the beginning of the next start. If a start is attempted before a full stop has happened, this can cause mechanical stress or a potential overload. During the restart delay period, the screen shows the time remaining before another start can be attempted.

The restart delay can be configured from 1 second to 60 minutes.

Starts Per Hour

The S711 limits how many starts the unit will attempt in a 60-minute period.

This value can be configured for 0 to 10 starts per hour.

Phase Sequence

The phase sequence selects what sequence the soft starter will allow at a start. During its pre-start checks, the S711 examines the sequence of the phases at its input terminals and trips if the actual sequence does not match the selected option. This can protect a system from running in the wrong direction than it is intended to.

Frequency Band

The upper and lower limits of the frequency can be configured to trip if the configured value is reached.

These values can both be configured from 35 Hz to 75 Hz.

Starter Protection*Fieldbus Fault Action*

The S711 can be configured to respond to each Fieldbus protection. All protection events are written to the event log. This protection allows for the following options.

- Stop & Fault
- Fault Auto Reset
- Fault Cost
- Warning
- Log Only
- Fault + Shunt Relay

Monitoring Capabilities

The S711 has an impressive array of system monitoring capabilities that allows users to access real time process and diagnostic data. This data can be viewed at the device with the keypad or through a communications network. Data over a communications network can provide valuable insight into the condition of the equipment and processes. Maintenance and production personnel can monitor critical operational and maintenance data from a central control station that can be located far away from the production facility. Process data can be monitored to determine system anomalies that may indicate a need for preventive maintenance or an impending failure. Adjustments made through the communications network can reduce costs by minimizing the time traveling to the location where the motor controls are located. When faults do occur, real time fault data can assist maintenance in troubleshooting and planning repair resources. Remote reset signals can be given to tripped devices without the need for manual intervention by maintenance personnel.

Average Phase Current

Provides the average rms current across all three phases. Current data can be used to indicate a need for maintenance. Increased currents in a fixed load application can indicate a reduction in system efficiencies and performance, signifying system maintenance is due.

Heatsink Temperature

Provides the soft starter's temperature, measured at the heatsink.

Bypass Model (%)

Provides the percentage of thermal capacity remaining in the bypass contactor.

Rating Capacity (%)

Provides the thermal capacity available in the soft starter for its next start.

Mains Frequency

Provides the average frequency measured on three phases.

Three-Phase Line Voltages

Provides the individual rms three-phase line voltages. Imbalances or changes in the relative phase voltage to one another can indicate anomalies in the motor or electrical distribution system. Voltage can be used to monitor electrical distribution system performance. Warnings, alarms and system actions to low or high voltage conditions can be implemented.

SCR Temperature

Provides the real-time temperature of the SCRs, calculated by the thermal model. A 100% value represents the maximum safe internal temperature of the motor. When the thermal model value reaches 100%, an overload trip will occur, removing power to the motor.

The thermal model value can be of great use in determining an impending overload trip condition. When using a communications network, alarms can be implemented in the process monitoring system warning of an impending trip before the trip occurs, halting the process. Costly system downtime can be avoided.

Hours Run

Counts the number of hours the motor has run via the soft starter.

Motor Power

Monitors the motor's running power in kilowatts or horsepower.

Motor Overload (%)

Monitors the motor overload percentage.

Start Count

Counts the number of starts the soft starter has complete since the start counter was last reset. Start count data can be used to monitor system output, schedule preventive maintenance, identify system anomalies and identify changes in system operation.

Power Factor

Provides the three-phase power factor value. The power factor of the circuit may be used to identify circuit conditions that may need to be corrected due to low power factor indications. Low circuit power factor can indicate improper or degraded components.

Diagnostics

Logs and Info

Logs and Info provides information on events, faults and starter performance. It also provides information on the software version the starter is currently running.

Event Log

The event log stores details of the starter's most recent faults, warnings and operations (including starts, stops and configuration changes). Event 1 is the most recent and the event with the largest number is the oldest stored event. The log records the number of days since the event. A maximum of 1000 records can be stored in the event log. This can be used for advanced troubleshooting and system integration activities.

Counters

Counters are how the S711 stores statistics on the starter's operation. Counters can store the following types of statistics:

- Hours run (lifetime and since counter last reset)
- Number of starts (lifetime and since counter last reset)
- Number of failed starts (lifetime and since counter last reset)
- Number of faults (lifetime and since counter last reset)
- Power used (lifetime and since counter last reset)

Standards and Certifications

Certifications	Details
Bluetooth LE module	FCC ID: 2AC7Z-ESP32WROVERE ISED ID: 21098-ESPWROVERE
CCC (Pending)	Low-voltage Switchgear & Control Gear Part 4-2 GB/T 14048.6 CE Low Voltage Directive (LVD) 2014/35/EU Radio Equipment Directive (RED) 2014/53/EU Electromagnetic Compatibility Directive (EMC) 2014/30/EU Restriction of Hazardous Substances Directive (RoHS) 2011/65/EU
UKCA	Electrical Equipment Safety Regulations 2016 No.1101 Radio Equipment Regulations 2017 No.1206 Electromagnetic Compatibility Regulations 2016 No.1091 Restriction of Hazardous Substances Regulations 2012 No.3032
CMIM (Pending)	LAW 24-09
RCM	Electrical Equipment Safety System
C-UL	CSA C22.2 No. 60947-4-2
UL	UL 60947-4-2
REACH	Restriction of Chemicals No 1907/2006 Enforcement Regulations 2008 No. 2852
Hazardous Substances	
China (Pending)	GB/T 26572-2011, SJ/T 11364-2014
UAE (Pending)	Cabinet Order No. 10/217
KSA (Pending)	01-09-21-179
USA	Minamata Convention on Mercury Proposition-65 Toxic Substances Control Act (TSCA) Conflict Minerals (Section 1502)
WEEE	Waste Electrical & Electronic Equipment Directive 2012/19/EU Waste Electrical & Electronic Equipment Regulations 2013 No.3113

Catalog Number Selection

S711 Open Soft Starters

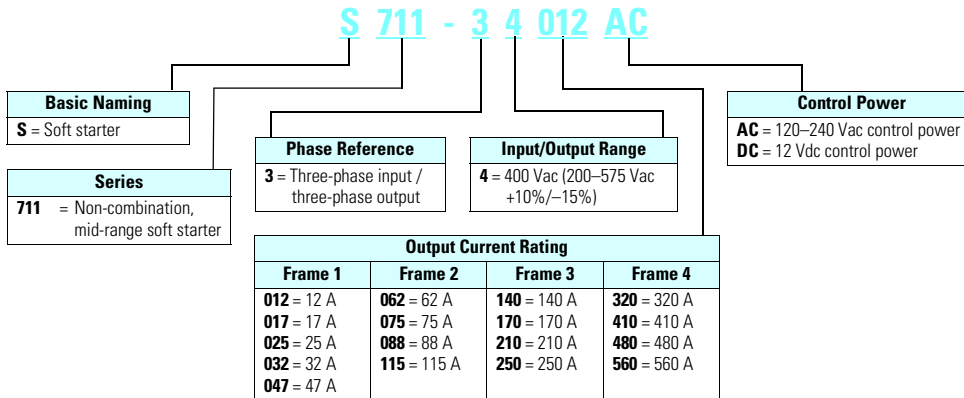

Product Selection

Application Ratings

Motor applications and customer needs come in many different varieties. With the standard and severe duty rating tables, we have attempted to provide guidelines on what the soft starter is capable of. If the application falls under these categories, you can use these charts. For other applications, or when a question arises, consult with your local Eaton representative or call our Technical Resource Center.

S711



Standard Duty—20-Second Ramp, 350% FLA at 50 °C, 6 Starts per Hour, Inline Connection

Rated Current	Three-Phase Motors		230 V	460 V	575 V	Catalog Number
	kW Rating (50 Hz)	hp Rating (60 Hz)				
	400 V	1.0SF	1.0SF	1.0SF	1.0SF	
Frame Size 1						
12	5.5	3	3	7.5	10	S711-34012AC S711-34012DC
17	7.5	5	5	10	15	S711-34017AC S711-34017DC
25	11	7.5	7.5	15	25	S711-34025AC S711-34025DC
32	15	10	10	25	30	S711-34032AC S711-34032DC
47	22	15	15	30	40	S711-34047AC S711-34047DC
Frame Size 2						
62	30	20	20	50	60	S711-34062AC S711-34062DC
75	37	20	25	50	75	S711-34075AC S711-34075DC
88	45	25	30	60	75	S711-34088AC S711-34088DC
115	55	30	40	75	100	S711-34115AC S711-34115DC
Frame Size 3						
140	75	40	50	100	150	S711-34140AC S711-34140DC
170	90	50	60	125	150	S711-34170AC S711-34170DC
210	110	60	75	150	200	S711-34210AC S711-34210DC
250	132	75	100	200	250	S711-34250AC S711-34250DC
Frame Size 4						
320	185	100	125	250	350	S711-34320AC S711-34320DC
410	220	125	150	350	450	S711-34410AC S711-34410DC
480	250	150	200	400	500	S711-34480AC S711-34480DC
560	315	200	200	450	600	S711-34560AC S711-34560DC

1

Severe Duty

Severe duty ratings are defined as any combination of parameters that exceed the standard duty ratings where the ramp time is over 30 seconds, and/or the number of starts per hour exceeds 6, and/or the current limit set is over 350%.

Example: 35-second ramp, 7 starts per hour, 400% current limit at 40 °C ambient.

S711



Severe Duty—30-Second Ramp, 450% FLA at 50 °C, 6 Starts per Hour, Inline Connection

Rated Current	Three-Phase Motors		230 V 1.0SF	460 V 1.0SF	575 V 1.0SF	Catalog Number
	kW Rating (50 Hz)	hp Rating (60 Hz)				
Frame Size 1						
12	5.5	2	3	7.5	10	S711-34012AC S711-34012DC
17	7.5	3	5	10	15	S711-34017AC S711-34017DC
25	11	5	7.5	15	25	S711-34025AC S711-34025DC
32	15	7.5	10	25	30	S711-34032AC S711-34032DC
47	22	10	15	30	40	S711-34047AC S711-34047DC
Frame Size 2						
62	30	10	20	50	60	S711-34062AC S711-34062DC
75	37	15	25	50	75	S711-34075AC S711-34075DC
88	45	20	30	60	75	S711-34088AC S711-34088DC
115	55	25	40	75	100	S711-34115AC S711-34115DC
Frame Size 3						
140	75	30	50	100	150	S711-34140AC S711-34140DC
170	90	40	60	125	150	S711-34170AC S711-34170DC
210	110	50	75	150	200	S711-34210AC S711-34210DC
250	132	60	100	200	250	S711-34250AC S711-34250DC
Frame Size 4						
320	185	75	125	250	350	S711-34320AC S711-34320DC
410	220	100	150	350	450	S711-34410AC S711-34410DC
480	250	100	200	400	500	S711-34480AC S711-34480DC
560	315	125	200	450	600	S711-34560AC S711-34560DC

Inside-the-Delta Standard Duty Ratings

S711



Standard Duty—20-Second Ramp, 350% FLA at 40 °C, 6 Starts per Hour, Inside-the-Delta Connection

Rated Current	Three-Phase Motors		230 V	460 V	575 V	Catalog Number
	kW Rating (50 Hz)	hp Rating (60 Hz)				
	400 V	1.0SF	1.0SF	1.0SF	1.0SF	
Frame Size 1						
12	5.5	5	5	10	15	S711-34012AC S711-34012DC
17	7.5	7.5	7.5	20	25	S711-34017AC S711-34017DC
25	11	10	10	25	30	S711-34025AC S711-34025DC
32	15	15	15	30	40	S711-34032AC S711-34032DC
47	22	20	25	50	60	S711-34047AC S711-34047DC
Frame Size 2						
62	30	25	30	60	75	S711-34062AC S711-34062DC
75	37	30	40	75	100	S711-34075AC S711-34075DC
88	45	40	50	100	125	S711-34088AC S711-34088DC
115	55	50	60	125	150	S711-34115AC S711-34115DC
Frame Size 3						
140	75	60	75	150	200	S711-34140AC S711-34140DC
170	90	75	100	200	250	S711-34170AC S711-34170DC
210	110	100	125	250	300	S711-34210AC S711-34210DC
250	132	125	150	300	400	S711-34250AC S711-34250DC
Frame Size 4						
320	185	150	200	400	500	S711-34320AC S711-34320DC
410	220	200	250	500	600	S711-34410AC S711-34410DC
480	250	250	300	600	700	S711-34480AC S711-34480DC
560	315	300	350	700	800	S711-34560AC S711-34560DC

1

Inside-the-Delta Severe Duty Ratings

Severe duty ratings are defined as any combination of parameters that exceed the standard duty ratings where the ramp time is over 30 seconds, and/or the number of starts per hour exceeds 6, and/or the current limit set is over 350%.

Example: 35-second ramp, 7 starts per hour 400% current limit at 40 °C ambient.

S711



Severe Duty—30-Second Ramp, 450% Current Limit at 40 °C, 6 Starts per Hour, Inside-the-Delta Connection

Rated Current	Three-Phase Motors		230 V	460 V	575 V	Catalog Number
	kW Rating (50 Hz)	hp Rating (60 Hz)				
	400 V	1.0SF	1.0SF	1.0SF	1.0SF	
Frame Size 1						
12	5.5	3	5	10	10	S711-34012AC S711-34012DC
17	7.5	5	5	10	15	S711-34017AC S711-34017DC
25	11	7.5	10	20	25	S711-34025AC S711-34025DC
32	15	10	10	25	30	S711-34032AC S711-34032DC
47	22	15	15	40	50	S711-34047AC S711-34047DC
Frame Size 2						
62	30	20	25	50	60	S711-34062AC S711-34062DC
75	37	25	30	60	75	S711-34075AC S711-34075DC
88	45	30	40	75	10	S711-34088AC S711-34088DC
115	55	40	50	100	125	S711-34115AC S711-34115DC
Frame Size 3						
140	75	50	50	125	150	S711-34140AC S711-34140DC
170	90	60	75	150	200	S711-34170AC S711-34170DC
210	110	75	75	150	200	S711-34210AC S711-34210DC
250	132	75	100	200	250	S711-34250AC S711-34250DC
Frame Size 4						
320	185	100	125	250	350	S711-34320AC S711-34320DC
410	220	125	150	350	450	S711-34410AC S711-34410DC
480	250	150	200	450	500	S711-34480AC S711-34480DC
560	315	200	250	500	600	S711-34560AC S711-34560DC

Accessories

Keypad

The keypad is available as a replacement part and can be used for either local or remote mounting.

Keypad

Description	Catalog Number
Keypad for all frame sizes	S711-KEY-LCD
Keypad replacement O-ring	S711-KEY-ORING

Replacement Fans

Fans are available as replacement parts for S711 frame size 2, 3 and 4 units. Frame size 1 does not have a replacement fan.

Fans

Description	Catalog Number
Replacement fan (frame size 2 and 3)	S711-SPR-FAN-80
Replacement fan (frame size 4)	S711-SPR-FAN-92

Finger Protection Kits

Clear finger protection covers for the bus bars on S711 frame sizes 3 and 4 (S711-34140... and up). Includes 1 each of top and bottom covers.

Finger Protection Kits

Description	Catalog Number
Frame size 3 finger protection kit	S711-XHB-FS3
Frame size 4 finger protection kit	S711-XHB-FS4

Communications Cards

EtherNet/IP, PROFINET and Modbus TCP communication protocols are available on S711 as option cards.

Communications Cards

Description	Catalog Number
EtherNet/IP option card	S711-NET-ETHERNET
PROFINET option card	S711-NET-PROFINET
Modbus TCP option card	S711-NET-MODBUSTCP
Replacement EtherNet/IP card cover	S711-SPR-ETH-COVER
Replacement PROFINET card cover	S711-SPR-NET-COVER

Technical Data and Specifications

Soft Starters—S711

Description	Frame 1	Frame 2	Frame 3	Frame 4
Max. current capacity	47	115	250	560
FLA range	10–100% unit rated current	10–100% unit rated current	10–100% unit rated current	10–100% unit rated current
General Information				
Bypass mechanical lifespan	100 K	100 K	100 K	100 K
Insulating voltage U_i	300 Vac	300 Vac	300 Vac	300 Vac
Ramp time range	1.0–180 seconds	1.0–180 seconds	1.0–180 seconds	1.0–180 seconds
Resistance to vibration	IEC 60068-2-6 (Fc)	IEC 60068-2-6 (Fc)	IEC 60068-2-6 (Fc)	IEC 60068-2-6 (Fc)
Resistance to shock	IEC 60068-2-27 (Ea)	IEC 60068-2-27 (Ea)	IEC 60068-2-27 (Ea)	IEC 60068-2-27 (Ea)
Electrical Information				
Operating voltage	200–575 V (+10% –15%)	200–575 V (+10% –15%)	200–575 V (+10% –15%)	200–575 V (+10% –15%)
Operating frequency	50–60 Hz (± 5 Hz)	50–60 Hz (± 5 Hz)	50–60 Hz (± 5 Hz)	50–60 Hz (± 5 Hz)
Overload setting	10–100%	10–100%	10–100%	10–100%
Trip class	5, 10, 20 and 30	5, 10, 20 and 30	5, 10, 20 and 30	5, 10, 20 and 30
Cabling Capacity (IEC 947)				
Number of conductors	1	1	1	1
Wire sizes	10–2/0	10–2/0	3/0–500	350–750
Type of connectors	—	—	Box lug	Box lug
Control Wiring (12-Pin)				
Wire sizes in AWG	28–12	28–12	28–12	28–12
Torque requirements in lb-in	4.3	4.3	4.3	4.3
Solid, stranded or flexible max. size in mm ²	2.5	2.5	2.5	2.5
Control Power Requirements				
Voltage range (24 V $\pm 10\%$)	19.2–28.8	19.2–28.8	19.2–28.8	19.2–28.8
Steady-state current amps	0.6	0.6	0.6	0.6
Relays				
Voltage AC—maximum, main contactor and programmable output	250	250	250	250
Amps (resistive)—maximum, main contactor	10	10	10	10
Amps (resistive)—maximum, programmable output	3	3	3	3
Environment				
Temperature—operating	–25 °C to +60 °C (above 40 °C with derating)	–25 °C to +60 °C (above 40 °C with derating)	–25 °C to +60 °C (above 40 °C with derating)	–25 °C to +60 °C (above 40 °C with derating)
Temperature—storage	–40 °C to +70 °C (+70 °C < 24 hr)	–40 °C to +70 °C (+70 °C < 24 hr)	–40 °C to +70 °C (+70 °C < 24 hr)	–40 °C to +70 °C (+70 °C < 24 hr)
Altitude	0–4000 m (above 1000 m with derating)	0–4000 m (above 1000 m with derating)	0–4000 m (above 1000 m with derating)	0–4000 m (above 1000 m with derating)
Humidity	5–95% relative humidity	5–95% relative humidity	5–95% relative humidity	5–95% relative humidity
Operating position	Any	Any	Any	Any
Pollution degree IEC947-1	3	3	3	3
Heat Dissipation				
During start	4.5 watts per ampere	4.5 watts per ampere	4.5 watts per ampere	4.5 watts per ampere
During run	≤ 35 watts approx	≤ 50 watts approx	≤ 120 watts approx	≤ 140 watts approx

Wiring Diagrams

In-line Installation, Internally Bypassed

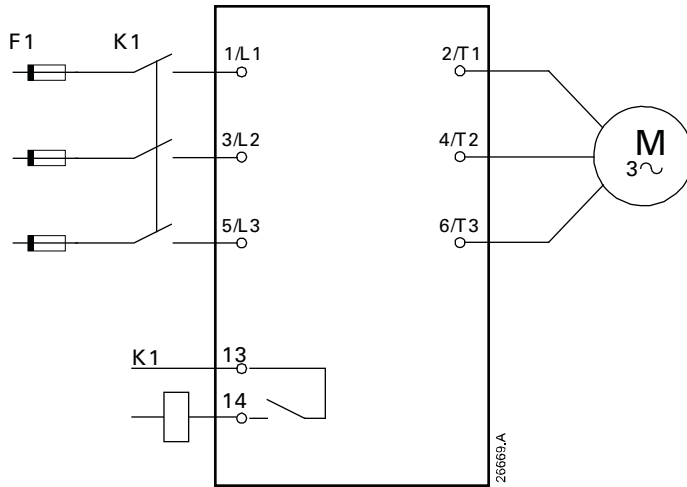

Inside Delta Installation, Internally Bypassed

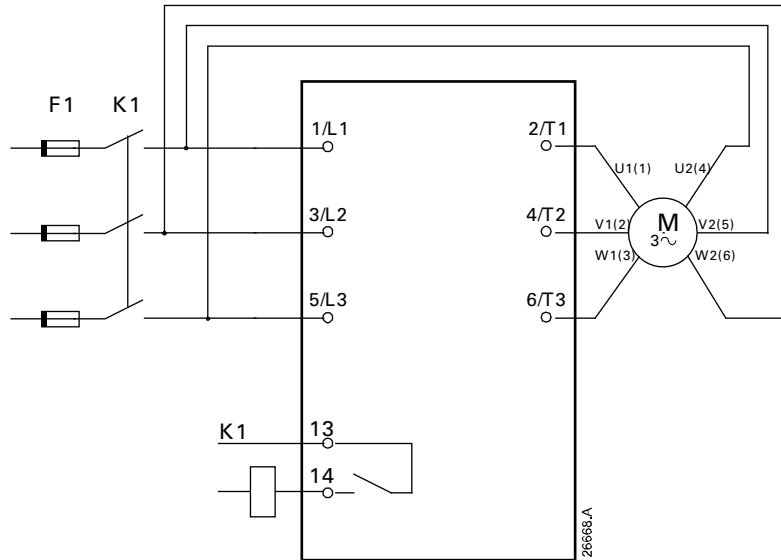

1.2

Reduced Voltage Motor Starters

Solid-State Starters

1

Dimensions

Approximate Dimensions in mm (inches)

Soft Starters—S711

		Width		Height		Depth E	Weight kg (lb)
		A	B	C	D		
Frame size 1	S711-34012...	128 (5.04)	102 (4.02)	252 (9.93)	234 (9.22)	174.5 (6.88)	3.6 (7.94)
	S711-34017...						
	S711-34025...						
	S711-34032...						
	S711-34047...						
Frame size 2	S711-34062...	128 (5.04)	102 (4.02)	281.3 (11.08)	263 (10.36)	190.2 (7.49)	5.1 (11.25)
	S711-34075...						
	S711-34088...						
	S711-341158...						
Frame size 3	S711-34140...	202.6 (7.98)	168 (6.62)	385.3 (15.18)	342.7 (13.50)	218.4 (8.60)	12.4 (27.34)
	S711-341708...						
	S711-34210...						
	S711-34250...						
Frame size 4	S711-34320...	222 (8.75)	175 (6.90)	545 (21.47)	492 (19.38)	204.5 (8.06)	18.5 (40.79)
	S711-34410...						
	S711-34480...						
	S711-34560...						

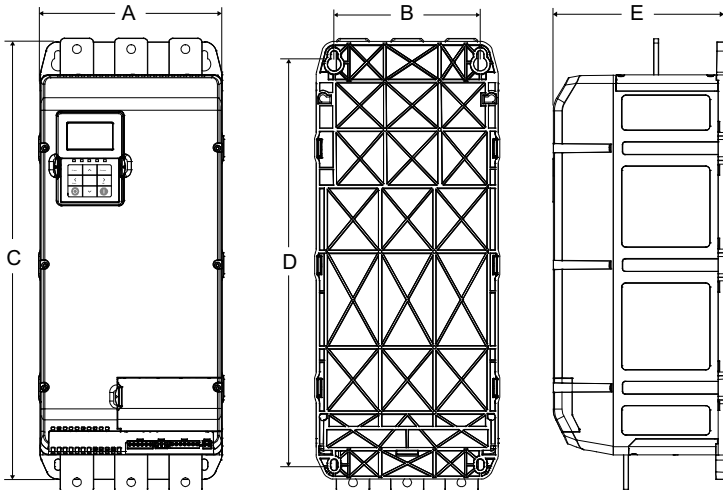
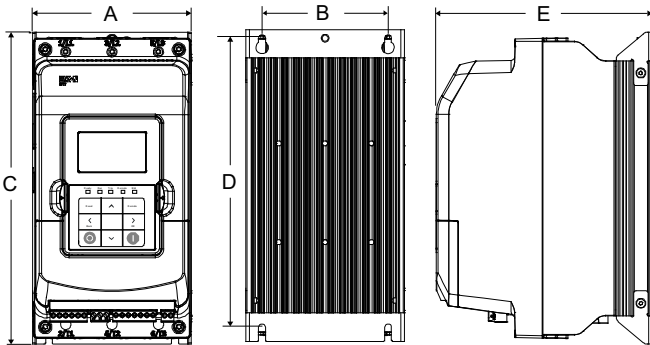

Approximate Dimensions in mm (inches)

S711 Frame 1

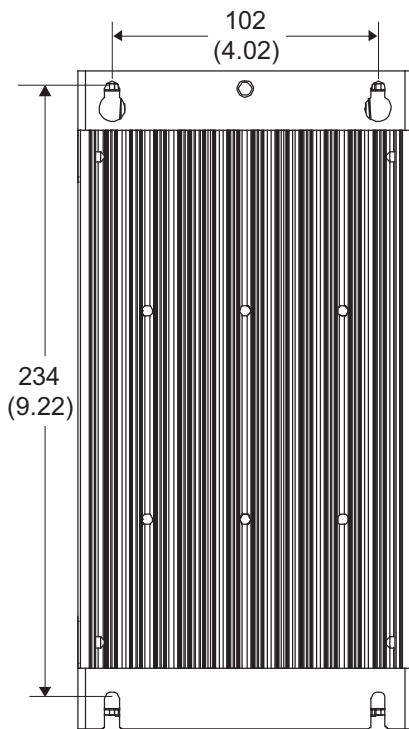
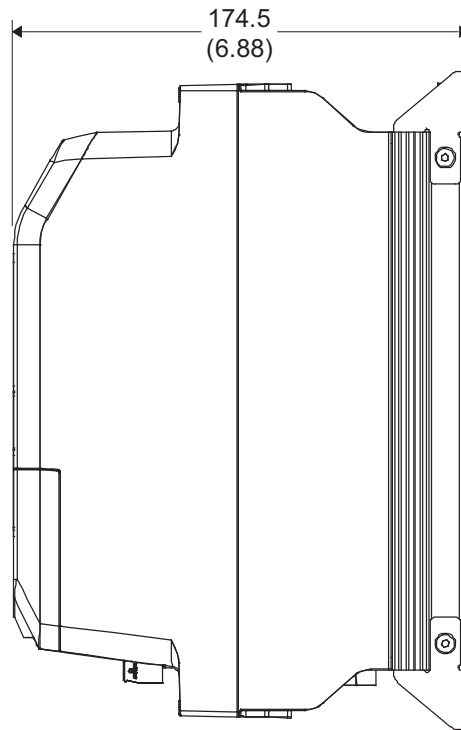
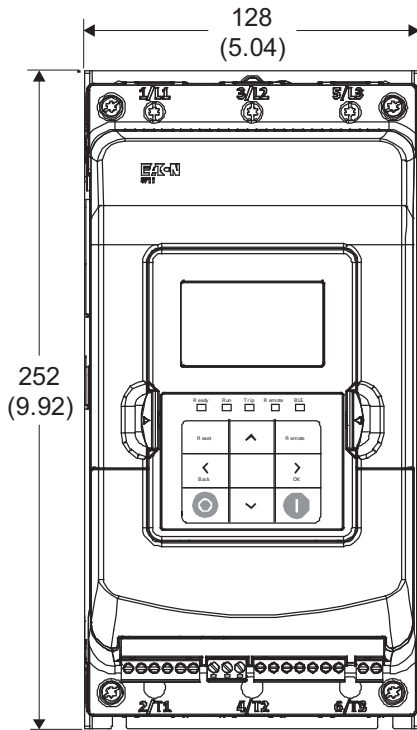

1.2

Reduced Voltage Motor Starters

Solid-State Starters

1

Approximate Dimensions in mm (inches)

S711 Frame 2

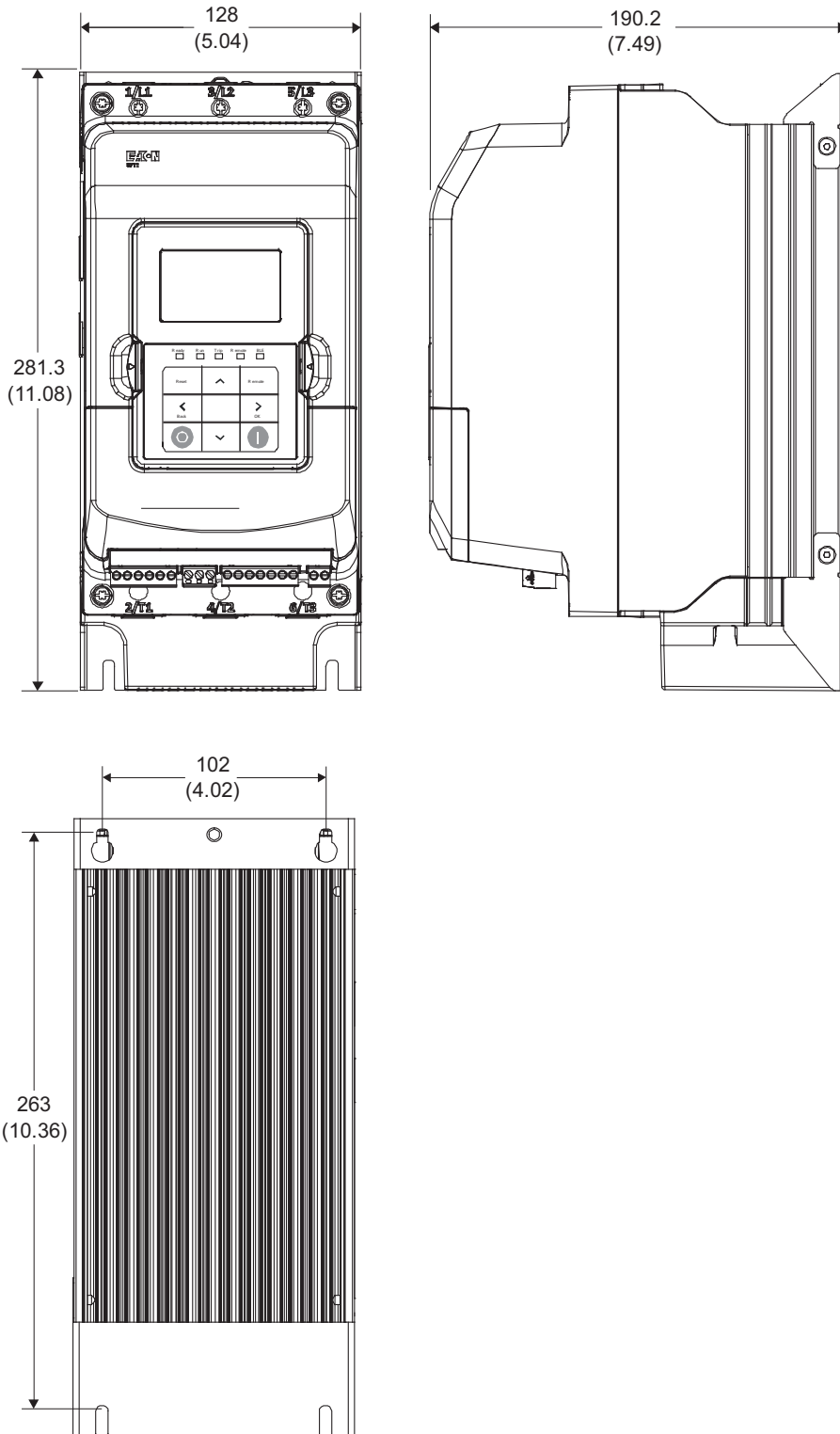

Approximate Dimensions in mm (inches)

S711 Frame 3

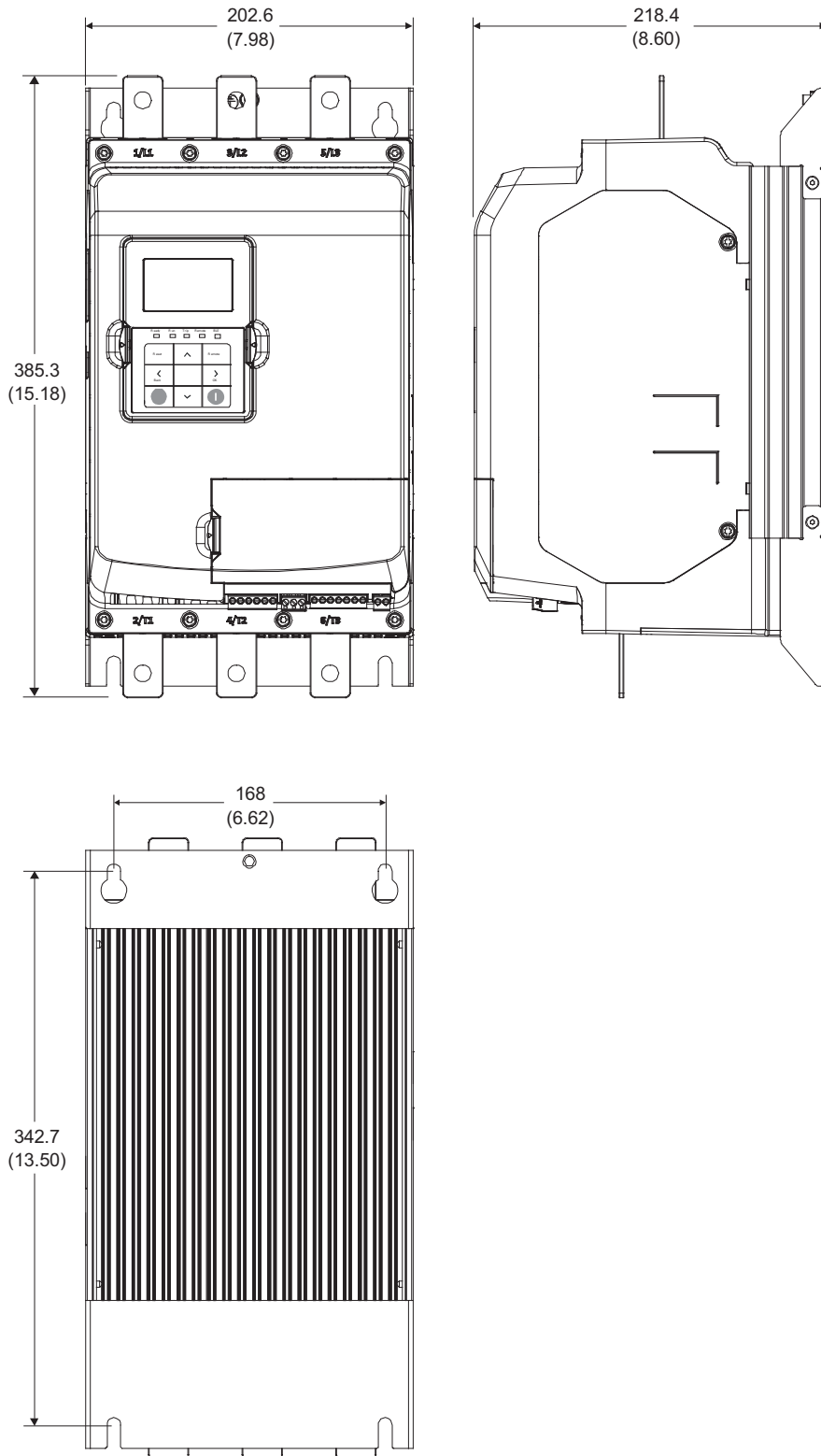

1.2

Reduced Voltage Motor Starters

Solid-State Starters

1

Approximate Dimensions in mm (inches)

S711 Frame 4

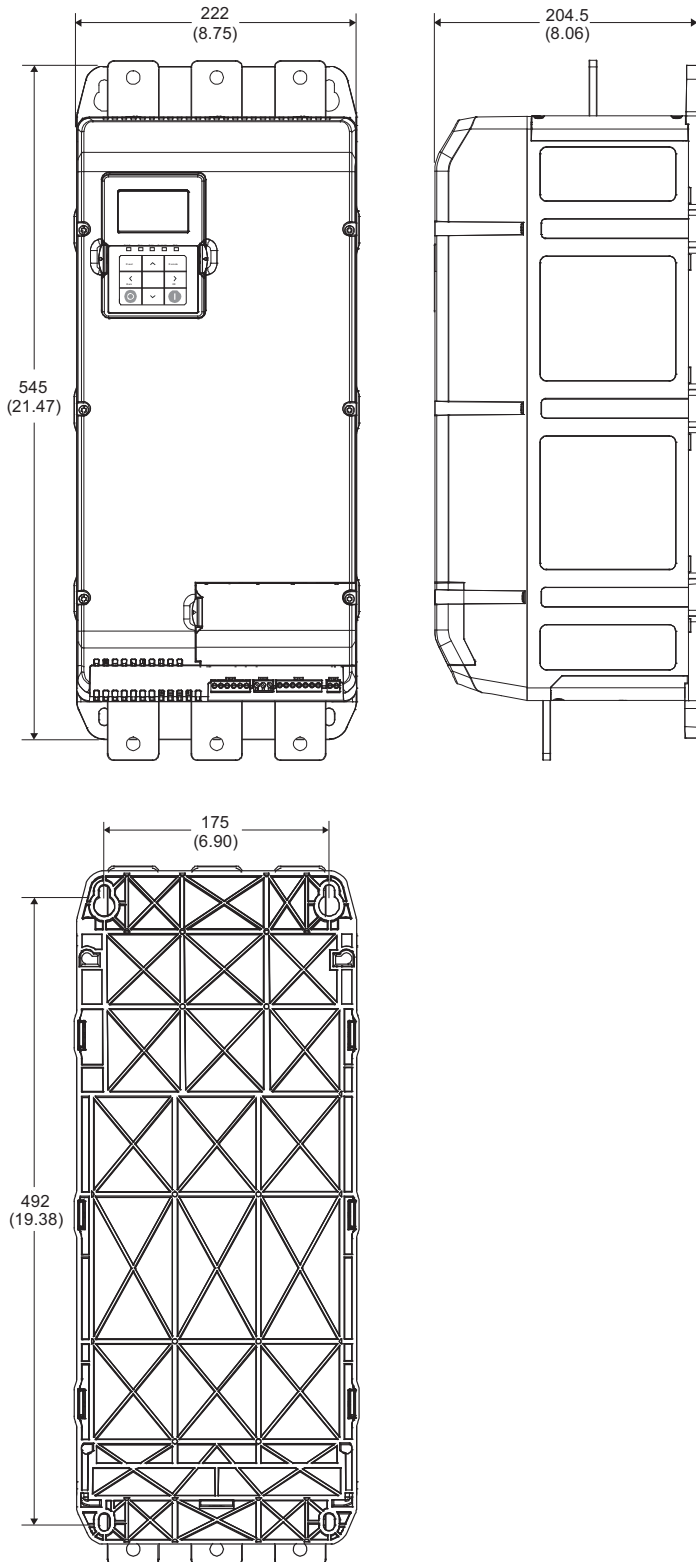

Type S801+ Soft Starters



Type S801+ Soft Starters

Product Description

Eaton's S801+ line of reduced voltage soft starters is very compact, multi-functional, easy to install and easy to program. Designed to control acceleration and deceleration of three-phase motors, the line is available for current ranges from 11 A all the way through 1000 A applications, and is suitable for mounting in motor control centers or in enclosed control (NEMA 1, 4, 4X and 12) applications.

Application Description

The S801+ line of soft starters is designed to be the smallest, most compact soft starter in the market today. With this small size, it can easily fit in place of existing soft starter designs, wye-delta starters or across-the-line NEMA and IEC starters. This feature allows easy retrofits of existing motor control centers or enclosures, and saves the expense of replacing existing structure or adding a new one to house a soft starter.

Contents

Description

	<i>Page</i>
Type S611 Soft Starters	V6-T1-43
Torque Limiters	V6-T1-59
S711 Soft Starters	V6-T1-61
Type S801+ Soft Starters	
Operation.	V6-T1-82
Features.	V6-T1-84
Benefits.	V6-T1-84
Standards and Certifications	V6-T1-84
User Manuals	V6-T1-84
Catalog Number Selection	V6-T1-84
Product Selection	V6-T1-85
Accessories.	V6-T1-87
Options	V6-T1-88
Technical Data and Specifications	V6-T1-89
Wiring Diagram	V6-T1-93
Dimensions	V6-T1-93
Type S811+ Soft Starters with DIM	V6-T1-97

The product is designed to work with three-phase motors in a delta (three-lead) configuration. The S801+ works with all motors from fractional horsepower up to motors requiring 1000 A of steady-state current. The built-in overload (in ranges from 11–1000 A) and run bypass contactor make installation and setup quick and easy. The overload also offers some advanced protective functions to give additional motor protection.

1

Operation

Overload Functionality

Overtemperature

Protects the device from overheating. Starter will shut down at 100 °C.

Stall

Selectable protective feature, unit trips to protect system in event motor can not get to rated speed in the defined ramp period.

Jam

Selectable protective feature, unit trips to prevent damage to motor during normal run.

Phase Loss

Selectable protective feature, trips under voltage loss condition to any phase.

Phase Reversal

Selectable protective feature, trips when phase rotation is something other than A-B-C.

Kick Start

Selectable feature that provides a current "kick" of up to 550% of full load current for 0 to 2.0 seconds. This provides the additional torque required at startup to break free a motor.

Ramp Start

Provides a constant increase in torque to the motor.

Current Limit Start

Limits the maximum current available to the motor during the startup phase.

Soft Stop

Allows for a controlled stopping of a frictional load.

Shorted SCR Detection

Monitors for shorted SCR in the power poles.

Starting Characteristics

Kick Start

Provides an initial boost of current to the motor to help overcome motor inertia and begin motor rotation.

- 0–85% of locked rotor torque
- 0–2.0 seconds duration

Starting Characteristics—Kick Start

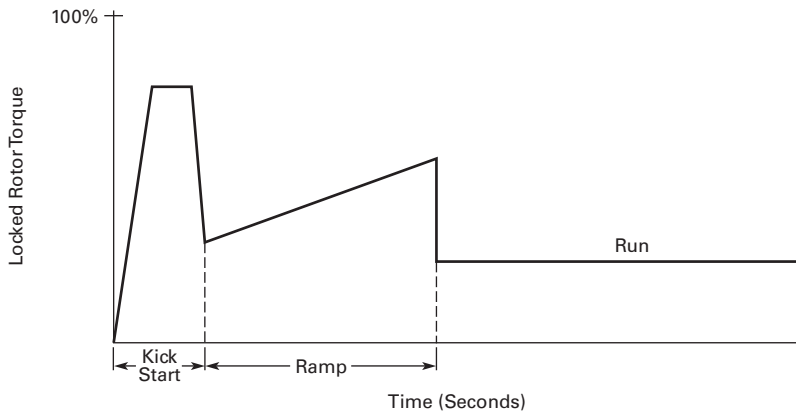

Ramp Start

The most commonly used form of soft start. This allows you to set the initial torque value (of the ramp) and then raises it to full voltage conditions.

- Adjustable initial torque = 0–85% of locked rotor torque
- Adjustable ramp time = 0.5–180 seconds

Starting Characteristics—Ramp Start

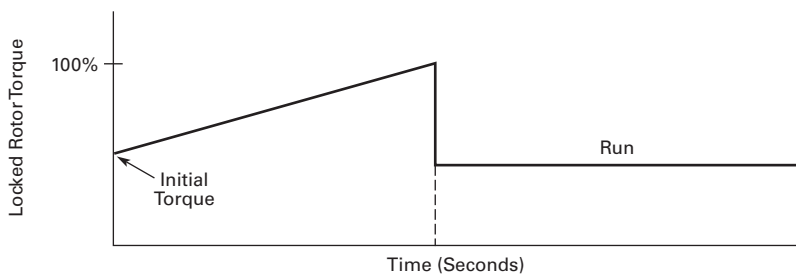

Current Limit

This mode of soft starting is used when it becomes necessary to limit the maximum starting current due to long start times or to protect the motor.

- Maximum current of 0–85% locked rotor current
- Adjustable ramp time = 0.5–180 seconds

Starting Characteristics—Current Limit

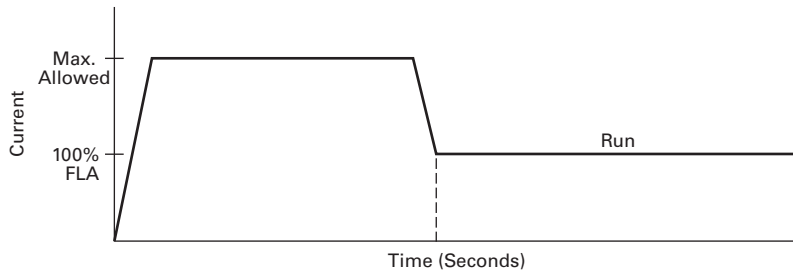

Soft Stop

Used when an extended coast-to-rest period is desired. Often used with high friction loads where a sudden stop may cause system or product damage.

- Stop time = 0–60 seconds

Starting Characteristics—Soft Stop

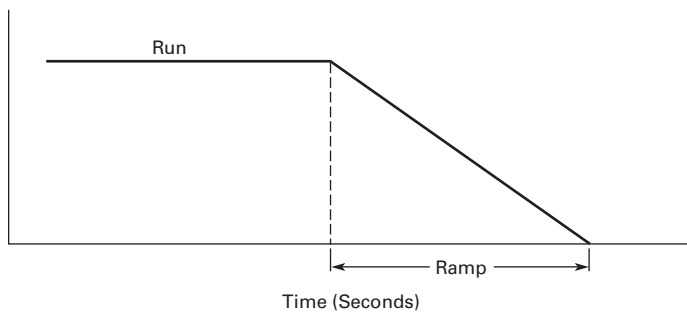

1

Features

- Built-in overload protection
- Built-in run bypass contactor
- Adjustable ramp times
- Adjustable torque control
- Adjustable kick start control
- Programmable overload settings, 31–100% (3.2:1) of rated current for the unit
- Physically fits in place of most NEMA and IEC starters
- Easy to use control interface module
- Soft stop control
- Multiple trip class settings (5, 10, 20 and 30)
- Six SCR control
- Optional CIM door mount kit for safety
- Optional IP20 protection

Benefits

- Reduced wear on belts, gears, chains, clutches, shafts and bearings
- Allows for controlling the inrush current to the motor
- Reduced inrush current leads to more stable power grid and can lower peak demand charges
- Less shock to product on conveyor lines and material handling gear
- 24 Vdc control enhances personnel and equipment safety

Standards and Certifications

- IEC 947 compliant
- EN 60947-4-2
- CSA certification
- cULus listed (File No. E202571)
- CE marked
- CSA elevator (2411 01)



User Manuals

A comprehensive user manual is available and can be downloaded free of charge from www.eaton.com by performing a document search for MN03900002E.

Catalog Number Selection

S801+ Open Soft Starters ^{①②}

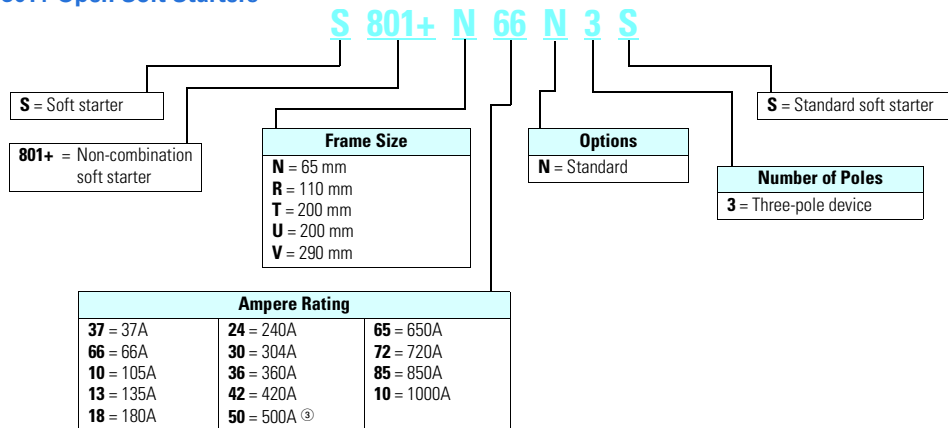

Notes

- ① S801+T..., S801+U..., and S801+V... units require lug kits found on **Page V6-T1-87**.
- ② All units require a 24 Vdc power supply found on catalog **Page V6-T1-87**, or equivalent.
- ③ S801+U50N35 unit does not have IEC certification.

Product Selection

Standard Duty Ratings

The table below is the base ratings for the soft starter. The tables included in this catalog are meant to be a reference table for different applications, but to match a unit to your exact application, consult with your local Eaton representative or call our Technical Resource Center.

Standard Duty Ratings

Starting Method	Ramp Current % of FLA	Ramp Time Seconds	Starts per Hour	Ambient Temperature
Soft start	300%	30 sec.	3	50 °C
Full voltage	500%	10 sec.	3	50 °C
Wye-delta	350%	20 sec.	3	50 °C
80% RVAT	480%	20 sec.	2	50 °C
65% RVAT	390%	20 sec.	3	50 °C
50% RVAT	300%	20 sec.	4	50 °C

Motor applications and customer needs come in many different varieties. With the standard and severe duty rating tables, we have attempted to provide

guidelines on what the soft starter is capable of. If the application falls under these categories, you can use these charts. For other applications, or when a

question arises, consult with your local Eaton representative or call our Technical Resource Center.

S801+



Standard Duty—15 Second Ramp, 300% Current Limit at 40 °C, Inline Connection

Rated Current	Three-Phase Motors kW Rating (50 Hz)			hp Rating (60 Hz)						Catalog Number		
	230 V	380–400 V	440 V	200 V		230 V		460 V			575–600 V	
				1.0SF	1.15SF	1.0SF	1.15SF	1.0SF	1.15SF		1.0SF	1.15SF
Frame Size N												
37	10	18.5	18.5	10	10	10	10	25	20	30	30	S801+N37N3S
66	18.5	30	37	20	15	20	20	50	40	60	50	S801+N66N3S
Frame Size R												
105	30	55	59	30	25	40	30	75	60	100	75	S801+R10N3S
135	40	63	80	40	30	50	40	100	75	125	100	S801+R13N3S
Frame Size T												
180	51	90	110	60	50	60	60	150	125	150	150	S801+T18N3S
240	75	110	147	75	60	75	75	200	150	200	200	S801+T24N3S
304	90	160	185	100	75	100	100	250	200	300	250	S801+T30N3S
Frame Size U												
360	110	185	220	125	100	150	125	300	250	350	300	S801+U36N3S
420	129	220	257	150	125	175	150	350	300	450	350	S801+U42N3S
500	150	257	300	150	150	200	150	400	350	500	450	S801+U50N3S ①
Frame Size V												
360	110	185	220	125	100	150	125	300	250	350	300	S801+V36N3S
420	129	220	257	150	125	175	150	350	300	450	350	S801+V42N3S
500	150	257	300	150	150	200	150	400	350	500	450	S801+V50N3S
650	200	355	425	250	200	250	200	500	450	600	500	S801+V65N3S
720	220	400	450	—	—	300	250	600	500	700	600	S801+V72N3S
850	257	475	500	—	—	350	300	700	600	900	700	S801+V85N3S
1000	277	525	550	—	—	400	350	800	700	900	800	S801+V10N3S

Note

① S801+U50N3S does not have IEC certification.

1

Severe Duty Ratings

The table below is the base ratings for the soft starter. The tables included in this catalog are meant to be a reference table for different applications, but to match a unit to your exact application, consult with your local Eaton representative or call our Technical Resource Center.

Severe Duty Ratings

Starting Method	Ramp Current % of FLA	Ramp Time Seconds	Starts per Hour	Ambient Temperature
Soft start	450%	30 sec.	4	50 °C
Full voltage	500%	10 sec.	10	50 °C
Wye-delta	350%	65 sec.	3	50 °C
80% RVAT	480%	25 sec.	4	50 °C
65% RVAT	390%	40 sec.	4	50 °C
50% RVAT	300%	60 sec.	4	50 °C

Severe duty ratings are defined as any combination of parameters that exceed the standard duty ratings where

the ramp time is over 30 seconds, and/or the number of starts per hour exceeds 4, and/or the current limit set is

over 300%. *Example:* 35-second ramp, 5 starts per hour, 350% current limit at 40 °C ambient.

S801+



Severe Duty —>30 Second Ramp, >300% Current Limit

Rated Current	Three-Phase Motor kW Rating (50 Hz)			hp Rating (60 Hz)				460 V		575 V		Catalog Number
	230 V	380–400 V	440 V	200 V 1.0SF	1.15SF	230 V 1.0SF	1.15SF	1.0SF	1.15SF	1.0SF	1.15SF	
Frame Size N												
22	5.5	10	11	5	5	7-1/2	5	15	10	20	15	S801+N37N3S
42	11	18.5	22	10	10	15	10	30	25	40	30	S801+N66N3S
Frame Size R												
65	15	30	33	15	15	20	15	50	40	50	50	S801+R10N3S
80	22	40	45	25	20	30	25	60	50	75	60	S801+R13N3S
Frame Size T												
115	33	59	63	30	30	40	30	75	75	100	100	S801+T18N3S
150	45	80	90	50	40	50	50	100	100	150	125	S801+T24N3S
192	55	100	110	60	50	75	60	150	125	200	150	S801+T30N3S
Frame Size U												
240	75	110	147	75	60	75	75	200	150	200	200	S801+U36N3S
305	90	160	185	100	75	100	100	250	200	300	250	S801+U42N3S
365	110	185	220	125	100	150	125	300	250	350	300	S801+U50N3S ①
Frame Size V												
240	75	110	147	75	60	75	75	200	150	200	200	S801+V36N3S
305	90	160	185	100	75	100	100	250	200	300	250	S801+V42N3S
365	110	185	220	125	100	150	125	300	250	350	300	S801+V50N3S
420	129	220	257	150	125	150	150	350	300	450	350	S801+V65N3S
480	147	257	295	150	150	200	150	400	350	500	450	S801+V72N3S
525	160	280	335	150	150	200	150	450	350	500	450	S801+V85N3S
600	185	315	375	200	150	250	200	500	450	600	500	S801+V10N3S

Note

① S801+U50N3S unit does not have IEC certification.

Accessories

Lug Kits

S801+T..., S801+U... and S801+V... soft starters each have different lug options based on your wiring needs.

Each lug kit contains three lugs that can be mounted on either the load or line side.

Lug Kit



Lug Kits

S801+ Catalog Number	Description	Kits Required	Catalog Number
S801+T..., S801+U...	2 cable connections, 4 AWG to 1/0 cable	2	EML22
	1 cable connection, 4/0 to 500 kcmil cable		EML23
	2 cable connections, 4/0 to 500 kcmil cable		EML24
	1 cable connection, 2/0 to 300 kcmil cable		EML25
	2 cable connections, 2/0 to 300 kcmil cable		EML26
S801+V...	2 cable connections, 4/0 to 500 kcmil cable	2	EML28
	4 cable connections, 4/0 to 500 kcmil cable		EML30
	6 cable connections, 4/0 to 500 kcmil cable		EML32
	4 cable connections, 2/0 to 300 kcmil cable		EML33

Power Supplies

24 Vdc power supply that can be used with the S801+ SSRV or as a stand-alone device.

Power Supplies

Description	Catalog Number
85–264 Vac input 24 Vdc output	PSG240E
360–575 Vac input 24 Vdc output	PSG240F
600 Vac input 24 Vdc output	PSS55D

Lug Cover Kits

Replacement covers for the S801+T... and S801+U... soft starters are available in case of damage to the existing covers.

Lug Cover Kits

Description	Catalog Number
Lug cover S801+T..., S801+U...	EML27
Lug cover S801+V...	EML34

IP20 Kits

IP20 Kits

Description	Catalog Number
S801+N...	SS-IP20-N
S801+R...	SS-IP20-R
S801+T... and S801+U...	SS-IP20-TU
S801+V...	SS-IP20-V

Surge Suppressors

The surge suppressor can mount on either the line or load side of the soft starter. It is designed to clip the line voltage (or load side induced voltage).

Surge Suppressor



Surge Suppressors

Description	Catalog Number
600 V MOV for S801+... units	EMS39
690 V MOV for S801+... units	EMS41

1

Mounting Plates

The mounting plates are designed to help make it easy to install or retrofit the soft starter into enclosures and MCCs. The soft starter can be mounted onto the plate prior to installation. The mounting plate is designed with tear drop mounting holes for easier installation.

Mounting Plates

Description	Catalog Number
S801+N...	EMM13N
S801+R...	EMM13R
S801+T... and S801+U...	EMM13T
S801+V...	EMM13V

Vibration Plates

The vibration plates allow the soft starter to be applied in high shock and vibration applications. The vibration plate allows vibration up to 5g and shock in up to 40g. The soft starter is mounted onto the vibration plate prior to installation in the panel.

Vibration Plates

Description	Catalog Number
S801+N...	EMM14N
S801+R...	EMM14R
S801+T... and S801+U...	EMM14T
S801+V...	EMM14V

Adapter Plates

The adapter plate allows customers to retrofit a S801+V... soft starter with the S801+U... soft starter.

Adapter Plates

Description	Catalog Number
Adapter plates	EMM13U

Control Wire Connector

Control Wire Connector

Description	Catalog Number
12-pin, 5 mm pitch connector for control wiring	EMA75

Control Interface Module

The Control Interface Module (CIM) is available as a replacement part.

CIM

Description	Catalog Number
Blank cover (filler)	EMA68
CIM for standard unit	EMA71
Panel mounting kit	
3 ft cable	EMA69A
5 ft cable	EMA69B
8 ft cable	EMA69C
10 ft cable	EMA69D

Options

Cooling Fan Kit

The EMM18 cooling fan kit mounts on either side of any frame size S801+ soft starter to provide additional printed circuit board cooling in high ambient operating temperatures.

Cooling Fan Kit

Description	Catalog Number
Fan kit	EMM18

Technical Data and Specifications

Soft Starters—S801+

Description	S801+N37N3S	S801+N66N3S	S801+R10N3S	S801+R13N3S
Max. current capacity	37	66	105	135
General Information				
Bypass mechanical lifespan	10 M	10 M	10 M	10 M
Insulating voltage Ui	660 V	660 V	660 V	660 V
Ramp time range	0.5–180 seconds	0.5–180 seconds	0.5–180 seconds	0.5–180 seconds
Resistance to vibration	3 g	3 g	3 g	3 g
Resistance to shock	15 g	15 g	15 g	15 g
Electrical Information				
Operating voltage	200–600 V	200–600 V	200–600 V	200–600 V
Operating frequency	47–63 Hz	47–63 Hz	47–63 Hz	47–63 Hz
Overload setting	30–100%	30–100%	30–100%	30–100%
Trip class	5, 10, 20 and 30	5, 10, 20 and 30	5, 10, 20 and 30	5, 10, 20 and 30
Cabling Capacity (IEC 947)				
Number of conductors	1	1	1	1
Wire sizes	14–2	14–2	14–4/0	14–4/0
Type of connectors	Box lug	Box lug	Box lug	Box lug
Control Wiring (12-Pin)				
Wire sizes in AWG	22–14	22–14	22–14	22–14
Number of conductors (stranded)	2 (or one AWG 12)	2 (or one AWG 12)	2 (or one AWG 12)	2 (or one AWG 12)
Torque requirements in lb-in	3.5	3.5	3.5	3.5
Solid, stranded or flexible max. size in mm ²	3.31	3.31	3.31	3.31
Control Power Requirements				
Voltage range (24 V ±10%)	21.6–26.4	21.6–26.4	21.6–26.4	21.6–26.4
Steady-state current amps	1.0	1.0	1.0	1.0
Inrush current amps	10	10	10	10
Ripple	1%	1%	1%	1%
Relays (1) Class A and C				
Voltage AC—maximum	240	240	240	240
Voltage DC—maximum	120	120	120	120
Amps—maximum	3	3	3	3
Environment				
Temperature—operating	–30 ° to 50 °C (no derating) consult factory for operation >50 °C	–30 ° to 50 °C (no derating) consult factory for operation >50 °C	–30 ° to 50 °C (no derating) consult factory for operation >50 °C	–30 ° to 50 °C (no derating) consult factory for operation >50 °C
Temperature—storage	–50 ° to 70 °C	–50 ° to 70 °C	–50 ° to 70 °C	–50 ° to 70 °C
Altitude	<2000 m—consult factory for operation >2000 m	<2000 m—consult factory for operation >2000 m	<2000 m—consult factory for operation >2000 m	<2000 m—consult factory for operation >2000 m
Humidity	<95% noncondensing	<95% noncondensing	<95% noncondensing	<95% noncondensing
Operating position	Any	Any	Any	Any
Pollution degree IEC947-1	3	3	3	3
Impulse withstand voltage IEC947-4-1	6000 V	6000 V	6000 V	6000 V

Soft Starters—S801+, continued

Description	S801+T18N3S	S801+T24N3S	S801+T30N3S	S801+U36N3S ①②
Max. current capacity	180	240	304	360
General Information				
Bypass mechanical lifespan	10 M	10 M	10 M	10 M
Insulating voltage U_i	660 V	660 V	660 V	660 V
Ramp time range	0.5–180 seconds	0.5–180 seconds	0.5–180 seconds	0.5–180 seconds
Resistance to vibration	3 g	3 g	3 g	3 g
Resistance to shock	15 g	15 g	15 g	15 g
Electrical Information				
Operating voltage	200–600 V	200–600 V	200–600 V	200–600 V
Operating frequency	47–63 Hz	47–63 Hz	47–63 Hz	47–63 Hz
Overload setting	30–100%	30–100%	30–100%	30–100%
Trip class	5, 10, 20 and 30	5, 10, 20 and 30	5, 10, 20 and 30	5, 10, 20 and 30
Cabling Capacity (IEC 947)				
Number of conductors	1 or 2	1 or 2	1 or 2	1 or 2
Wire sizes	4 AWG to 500 kcmil	4 AWG to 500 kcmil	4 AWG to 500 kcmil	4 AWG to 500 kcmil
Type of connectors	Add-on lug kit	Add-on lug kit	Add-on lug kit	Add-on lug kit
Control Wiring (12-Pin)				
Wire sizes in AWG	22–14	22–14	22–14	22–14
Number of conductors (stranded)	2 (or one AWG 12)	2 (or one AWG 12)	2 (or one AWG 12)	2 (or one AWG 12)
Torque requirements in lb-in	3.5	3.5	3.5	3.5
Solid, stranded or flexible max. size in mm ²	3.31	3.31	3.31	3.31
Control Power Requirements				
Voltage range (24 V ±10%)	21.6–26.4	21.6–26.4	21.6–26.4	21.6–26.4
Steady-state current amps	1.0	1.0	1.0	1.0
Inrush current amps	10	10	10	10
Ripple	1%	1%	1%	1%
Relays (1) Class A and C				
Voltage AC—maximum	240	240	240	240
Voltage DC—maximum	120	120	120	120
Amps—maximum	3	3	3	3
Environment				
Temperature—operating	–30 ° to 50 °C (no derating) consult factory for operation >50 °C	–30 ° to 50 °C (no derating) consult factory for operation >50 °C	–30 ° to 50 °C (no derating) consult factory for operation >50 °C	–30 ° to 50 °C (no derating) consult factory for operation >50 °C
Temperature—storage	–50 ° to 70 °C	–50 ° to 70 °C	–50 ° to 70 °C	–50 ° to 70 °C
Altitude	<2000 m—consult factory for operation >2000 m	<2000 m—consult factory for operation >2000 m	<2000 m—consult factory for operation >2000 m	<2000 m—consult factory for operation >2000 m
Humidity	<95% noncondensing	<95% noncondensing	<95% noncondensing	<95% noncondensing
Operating position	Any	Any	Any	Any
Pollution degree IEC947-1	3	3	3	3
Impulse withstand voltage IEC947-4-1	6000 V	6000 V	6000 V	6000 V

Notes

① 801+U50N3S unit does not have IEC certification.

② UL recognized component.

Soft Starters—S801+, continued

Description	S801+U42N3S	S801+U50N3S ①	S801+V36N3S	S801+V42N3S
Max. current capacity	420	500	360	420
General Information				
Bypass mechanical lifespan	10 M	10 M	10 M	10 M
Insulating voltage U_i	660 V	660 V	660 V	660 V
Ramp time range	0.5–180 seconds	0.5–180 seconds	0.5–180 seconds	0.5–180 seconds
Resistance to vibration	3 g	3 g	3 g	3 g
Resistance to shock	15 g	15 g	15 g	15 g
Electrical Information				
Operating voltage	200–600 V	200–600 V	200–600 V	200–600 V
Operating frequency	47–63 Hz	47–63 Hz	47–63 Hz	47–63 Hz
Overload setting	30–100%	30–100%	30–100%	30–100%
Trip class	5, 10, 20 and 30	5, 10, 20 and 30	5, 10, 20 and 30	5, 10, 20 and 30
Cabling Capacity (IEC 947)				
Number of conductors	1 or 2	1 or 2	2, 4 or 6	2, 4 or 6
Wire sizes	4 AWG to 500 kcmil	4 AWG to 500 kcmil	2/0 to 500 kcmil	2/0 to 500 kcmil
Type of connectors	Add-on lug kit	Add-on lug kit	Add-on lug kit	Add-on lug kit
Control Wiring (12-Pin)				
Wire sizes in AWG	22–14	22–14	22–14	22–14
Number of conductors (stranded)	2 (or one AWG 12)	2 (or one AWG 12)	2 (or one AWG 12)	2 (or one AWG 12)
Torque requirements in lb-in	3.5	3.5	3.5	3.5
Solid, stranded or flexible max. size in mm ²	3.31	3.31	3.31	3.31
Control Power Requirements				
Voltage range (24 V ±10%)	21.6–26.4	21.6–26.4	21.6–26.4	21.6–26.4
Steady-state current amps	1.0	1.0	1.4	1.4
Inrush current amps	10	10	10	10
Ripple	1%	1%	1%	1%
Relays (1) Class A and C				
Voltage AC—maximum	240	240	240	240
Voltage DC—maximum	120	120	120	120
Amps—maximum	3	3	3	3
Environment				
Temperature—operating	–30 ° to 50 °C (no derating) consult factory for operation >50 °C	–30 ° to 50 °C (no derating) consult factory for operation >50 °C	–30 ° to 50 °C (no derating) consult factory for operation >50 °C	–30 ° to 50 °C (no derating) consult factory for operation >50 °C
Temperature—storage	–50 ° to 70 °C	–50 ° to 70 °C	–50 ° to 70 °C	–50 ° to 70 °C
Altitude	<2000 m—consult factory for operation >2000 m	<2000 m—consult factory for operation >2000 m	<2000 m—consult factory for operation >2000 m	<2000 m—consult factory for operation >2000 m
Humidity	<95% noncondensing	<95% noncondensing	<95% noncondensing	<95% noncondensing
Operating position	Any	Any	Any	Any
Pollution degree IEC947-1	3	3	3	3
Impulse withstand voltage IEC947-4-1	6000 V	6000 V	6000 V	6000 V

Note

① 801+U50N3S unit does not have IEC certification.

Soft Starters—S801+, continued

Description	S801+V50N3S	S801+V65N3S	S801+V72N3S	S801+V85N3S	S801+V10N3S ^①
Max. current capacity	500	650	720	850	1000
Dimensions					
Width in inches (mm)	11.03 (280.2)	11.03 (280.2)	11.03 (280.2)	11.03 (280.2)	11.03 (280.2)
Height in inches (mm)	16.57 (420.8)	16.57 (420.8)	16.57 (420.8)	16.57 (420.8)	16.57 (420.8)
Depth in inches (mm)	7.23 (183.7)	7.23 (183.7)	7.23 (183.7)	7.23 (183.7)	7.23 (183.7)
Weight in lb (kg)	103 (46.8) with lugs 91 (41.4) without lugs	103 (46.8) with lugs 91 (41.4) without lugs	103 (46.8) with lugs 91 (41.4) without lugs	103 (46.8) with lugs 91 (41.4) without lugs	103 (46.8) with lugs 91 (41.4) without lugs
General Information					
Bypass mechanical lifespan	10 M	10 M	10 M	10 M	10 M
Insulating voltage U _i	660 V	660 V	660 V	660 V	660 V
Ramp time range	0.5–180 seconds	0.5–180 seconds	0.5–180 seconds	0.5–180 seconds	0.5–180 seconds
Resistance to vibration	3 g	3 g	3 g	3 g	3 g
Resistance to shock	15 g	15 g	15 g	15 g	15 g
Electrical Information					
Operating voltage	200–600 V	200–600 V	200–600 V	200–600 V	200–600 V
Operating frequency	47–63 Hz	47–63 Hz	47–63 Hz	47–63 Hz	47–63 Hz
Overload setting	30–100%	30–100%	30–100%	30–100%	30–100%
Trip class	5, 10, 20 and 30	5, 10, 20 and 30	5, 10, 20 and 30	5, 10, 20 and 30	5, 10, 20 and 30
Cabling Capacity (IEC 947)					
Number of conductors	2, 4 or 6	2, 4 or 6	2, 4 or 6	2, 4 or 6	2, 4 or 6
Wire sizes	2/0 to 500 kcmil	2/0 to 500 kcmil	2/0 to 500 kcmil	2/0 to 500 kcmil	2/0 to 500 kcmil
Type of connectors	Add-on lug kit	Add-on lug kit	Add-on lug kit	Add-on lug kit	Add-on lug kit
Control Wiring (12-Pin)					
Wire sizes in AWG	22–14	22–14	22–14	22–14	22–14
Number of conductors (stranded)	2 (or one AWG 12)	2 (or one AWG 12)	2 (or one AWG 12)	2 (or one AWG 12)	2 (or one AWG 12)
Torque requirements in lb-in	3.5	3.5	3.5	3.5	3.5
Solid, stranded or flexible max. size in mm ²	3.31	3.31	3.31	3.31	3.31
Control Power Requirements					
Voltage range (24 V ±10%)	21.6–26.4	21.6–26.4	21.6–26.4	21.6–26.4	21.6–26.4
Steady-state current amps	1.4	1.4	1.4	1.4	1.4
Inrush current amps	10	10	10	10	10
Ripple	1%	1%	1%	1%	1%
Relays (1) Class A and C					
Voltage AC—maximum	240	240	240	240	240
Voltage DC—maximum	120	120	120	120	120
Amps—maximum	3	3	3	3	3
Environment					
Temperature—operating	–30 ° to 50 °C (no derating) consult factory for operation >50 °C	–30 ° to 50 °C (no derating) consult factory for operation >50 °C	–30 ° to 50 °C (no derating) consult factory for operation >50 °C	–30 ° to 50 °C (no derating) consult factory for operation >50 °C	–30 ° to 50 °C (no derating) consult factory for operation >50 °C
Temperature—storage	–50 ° to 70 °C	–50 ° to 70 °C	–50 ° to 70 °C	–50 ° to 70 °C	–50 ° to 70 °C
Altitude	<2000 m—consult factory for operation >2000 m	<2000 m—consult factory for operation >2000 m	<2000 m—consult factory for operation >2000 m	<2000 m—consult factory for operation >2000 m	<2000 m—consult factory for operation >2000 m
Humidity	<95% noncondensing	<95% noncondensing	<95% noncondensing	<95% noncondensing	<95% noncondensing
Operating position	Any	Any	Any	Any	Any
Pollution degree IEC947-1	3	3	3	3	3
Impulse withstand voltage IEC947-4-1	6000 V	6000 V	6000 V	6000 V	6000 V

Note

① UL recognized component.

Wiring Diagram

Line Connected Soft Starter

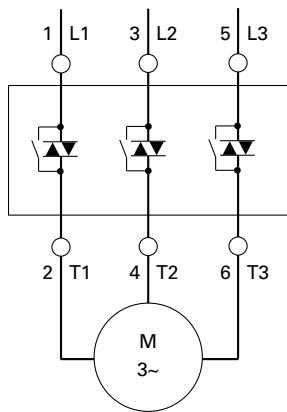

Dimensions

Approximate Dimensions in Inches (mm)

Soft Starters—S801+

Catalog Number	W	H	D	Weight in lb (kg)
S801+N37N3S	2.66 (67.6)	7.37 (187.2)	6.45 (163.9)	5.8 (2.6)
S801+N66N3S	2.66 (67.6)	7.37 (187.2)	6.45 (163.9)	5.8 (2.6)
S801+R10N3S	4.38 (111.3)	7.92 (201.1)	6.64 (168.6)	10.5 (4.8)
S801+R13N3S	4.38 (111.3)	7.92 (201.1)	6.64 (168.6)	10.5 (4.8)
S801+T18N3S	7.65 (194.4)	12.71 (322.9)	6.47 (164.4)	48 (21.8) with lugs 41 (18.6) without lugs
S801+T24N3S	7.65 (194.4)	12.71 (322.9)	6.47 (164.4)	48 (21.8) with lugs 41 (18.6) without lugs
S801+T30N3S	7.65 (194.4)	12.71 (322.9)	6.47 (164.4)	48 (21.8) with lugs 41 (18.6) without lugs
S801+U36N3S	7.73 (196.3)	12.72 (323.1)	7.16 (181.8)	48 (21.8) with lugs 41 (18.6) without lugs
S801+U42N3S	7.73 (196.3)	12.72 (323.1)	7.16 (181.8)	48 (21.8) with lugs 41 (18.6) without lugs
S801+U50N3S	7.73 (196.3)	12.72 (323.1)	7.16 (181.8)	48 (21.8) with lugs 41 (18.6) without lugs
S801+V36N3S	11.05 (280.6)	16.57 (420.8)	7.39 (187.8)	103 (46.8) with lugs 91 (41.4) without lugs
S801+V42N3S	11.05 (280.6)	16.57 (420.8)	7.39 (187.8)	103 (46.8) with lugs 91 (41.4) without lugs
S801+V50N3S	11.05 (280.6)	16.57 (420.8)	7.39 (187.8)	103 (46.8) with lugs 91 (41.4) without lugs
S801+V65N3S	11.05 (280.6)	16.57 (420.8)	7.39 (187.8)	103 (46.8) with lugs 91 (41.4) without lugs
S801+V72N3S	11.05 (280.6)	16.57 (420.8)	7.39 (187.8)	103 (46.8) with lugs 91 (41.4) without lugs
S801+V85N3S	11.05 (280.6)	16.57 (420.8)	7.39 (187.8)	103 (46.8) with lugs 91 (41.4) without lugs
S801+V10N3S	11.05 (280.6)	16.57 (420.8)	7.39 (187.8)	103 (46.8) with lugs 91 (41.4) without lugs

Also refer to dimension drawings on **Pages V6-T1-94 through V6-T1-96.**

1.2

Reduced Voltage Motor Starters

Solid-State Starters

1

Approximate Dimensions in Inches (mm)

S801+N...

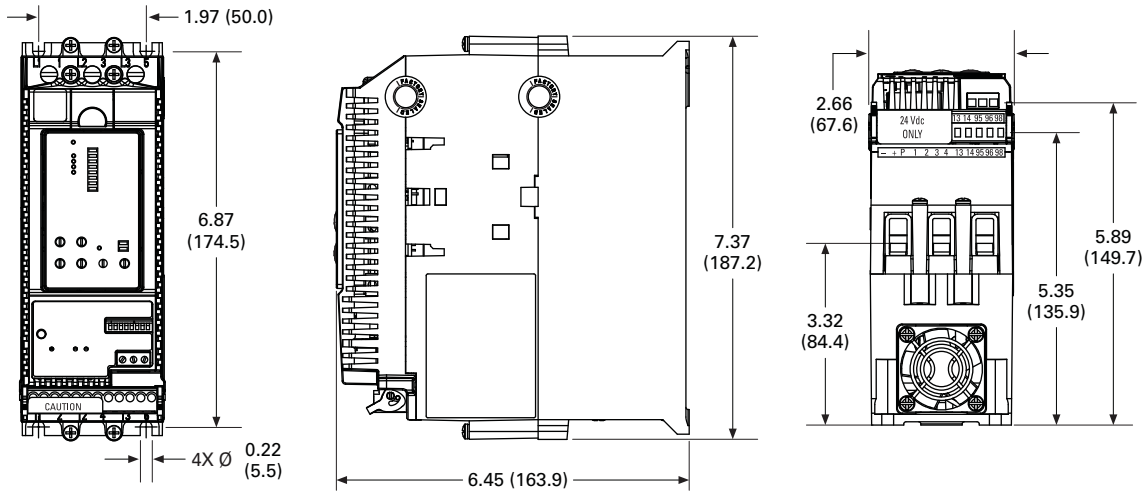

S801+R...

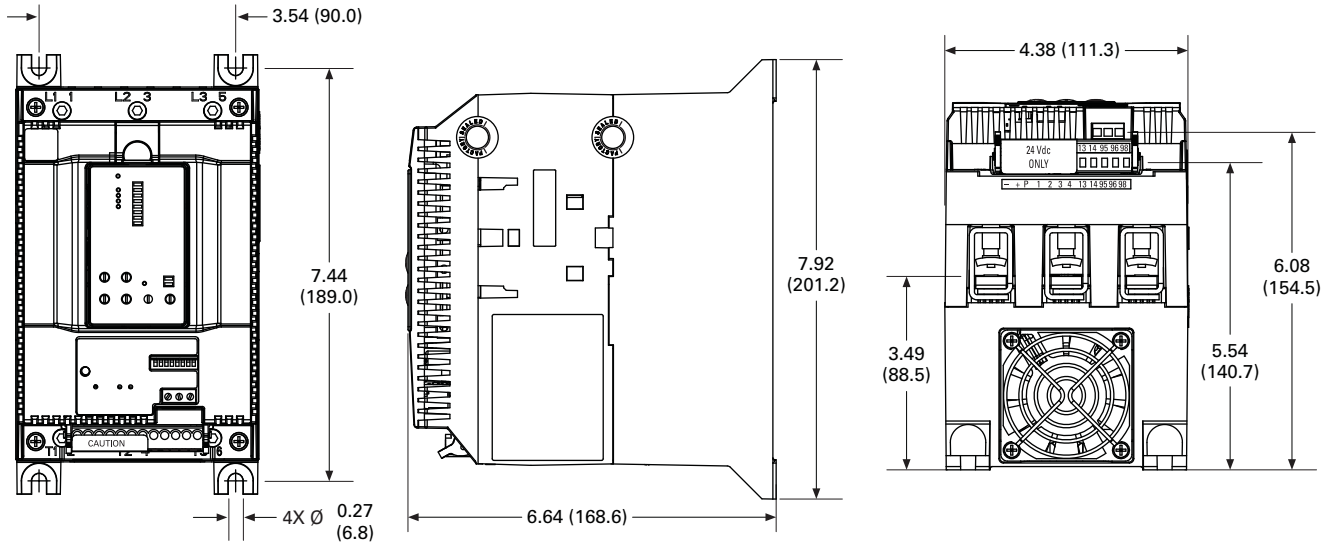

Approximate Dimensions in Inches (mm)

S801+T...

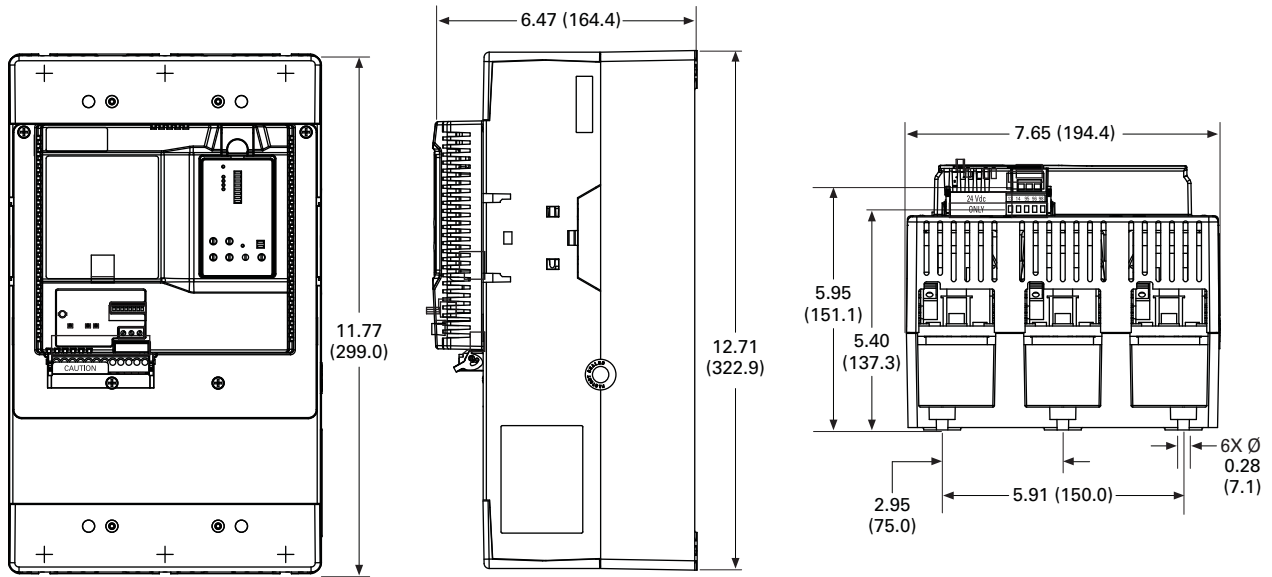

S801+U...

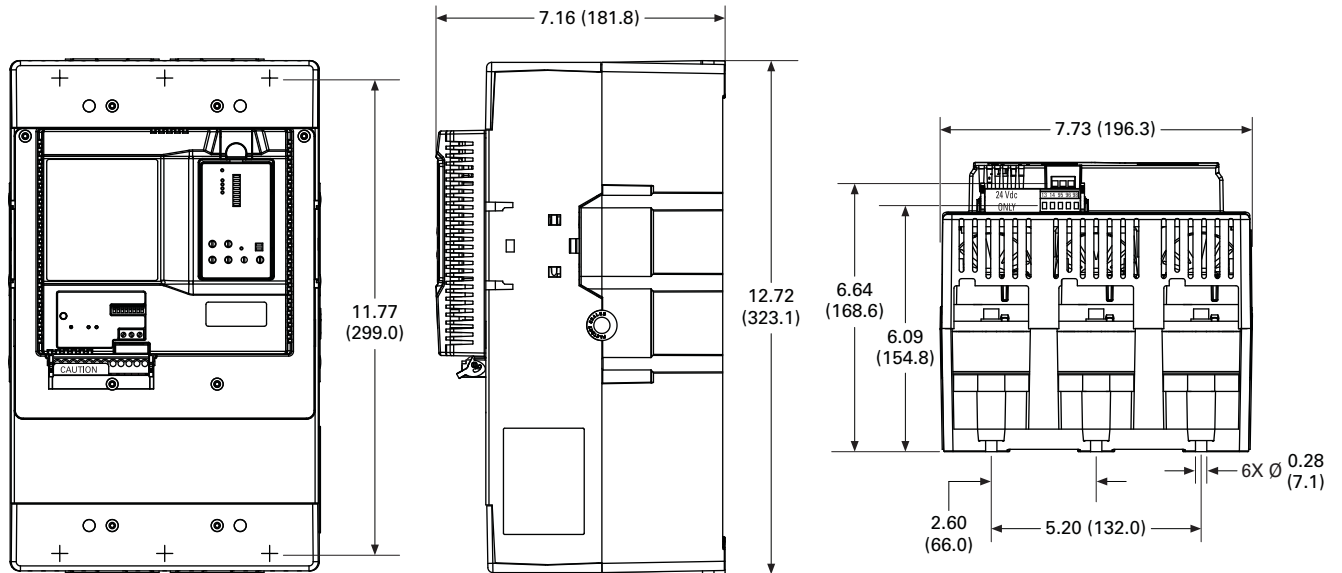

1.2

Reduced Voltage Motor Starters

Solid-State Starters

1

Approximate Dimensions in Inches (mm)

S801+V...

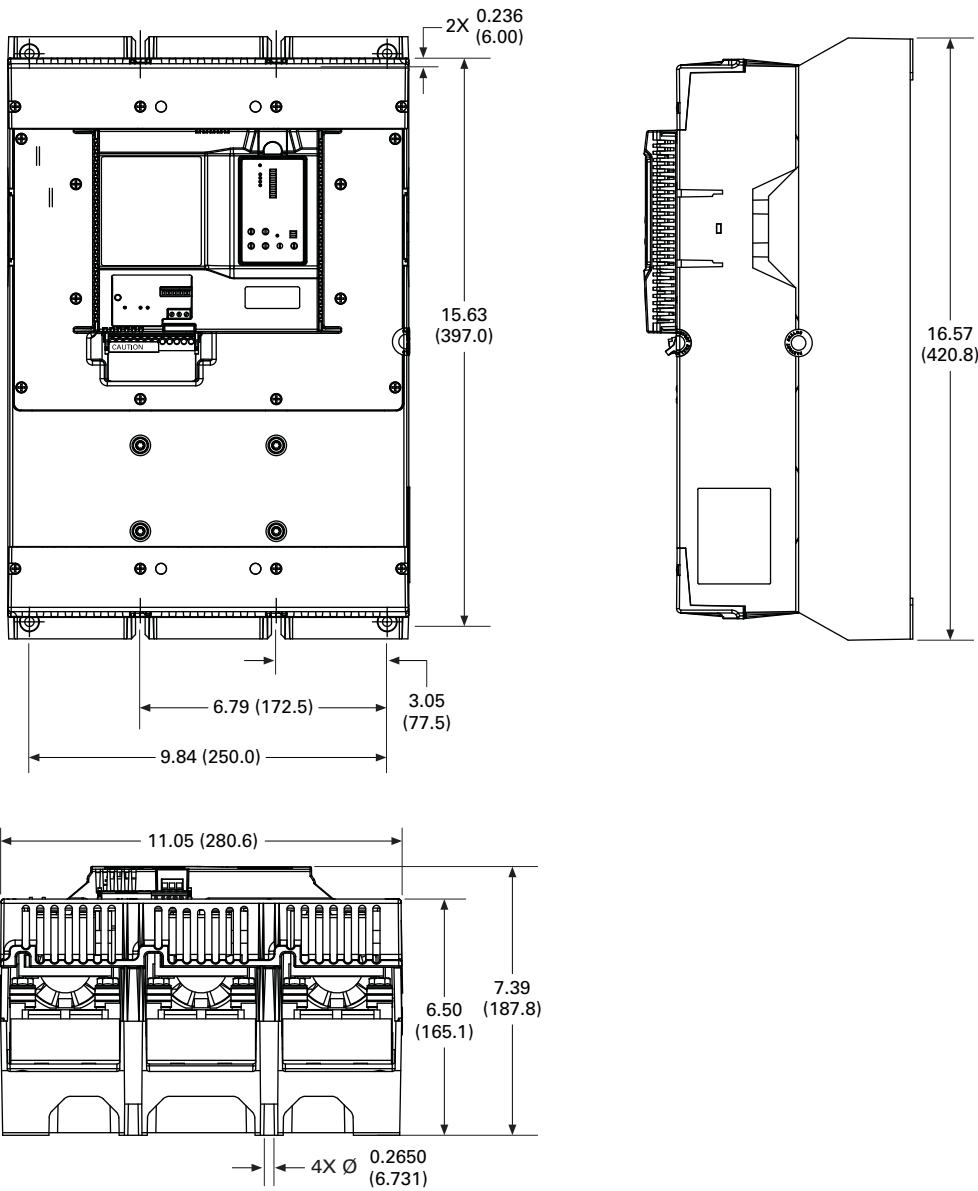

Type S811+ Soft Starters with Digital Interface Module (DIM)



Contents

Description	Page
Type S611 Soft Starters	V6-T1-43
Torque Limiters	V6-T1-59
S711 Soft Starters	V6-T1-61
Type S801+ Soft Starters	V6-T1-81
Type S811+ Soft Starters with DIM	
Communications	V6-T1-98
Operation	V6-T1-98
Features and Benefits	V6-T1-101
Standards and Certifications	V6-T1-105
Instructional Leaflets	V6-T1-105
Catalog Number Selection	V6-T1-105
Product Selection	V6-T1-106
Accessories	V6-T1-110
Options	V6-T1-111
Technical Data and Specifications	V6-T1-112
Wiring Diagrams	V6-T1-116
Dimensions	V6-T1-117

Type S811+ Soft Starters with DIM

Product Description

Eaton's S811+ offers all the popular features of the S801+ and adds new enhanced functionality with the new Digital Interface Module (DIM), communications, metering, monitoring and diagnostics capabilities.

Eaton's line of S811+ reduced voltage soft starters is very compact, multi-functional, easy to install and easy to set operating parameters. Designed to control the acceleration and deceleration of three-phase motors up to 690 V, the line is available from 11 A to 1000 A.

The S811+ is designed to be a complete package, combining the silicon controlled rectifiers (SCRs), bypass contactor and overload in one, very compact unit. The S811+ is available as a component for panel mounting, in motor control centers or in enclosed control (NEMA Type 1, 3R, 4, 4X, 7/9 and 12).

Application Description

Designed to control the acceleration and deceleration of three-phase motors, the S811+ soft starter uses SCRs to control the voltage to soft start and soft stop the motor. After the motor is started, internal run bypass contactors close, resulting in the motor running directly across-the-line. The built-in solid-state overload protects the motor from overload conditions with sophisticated algorithms that model true motor heating, resulting in better motor protection and fewer nuisance trips. Advanced protective and diagnostic features reduce downtime.

A voltage ramp start or current limit start is available. Kick start is available in either starting mode. The soft stop option allows for a ramp stop time that is longer than the coast to stop time. The pump control option in the S811+ Premium provides a smooth transition for starting and stopping a motor and eliminating the "water-hammer" effect that can damage pipes, valves and pumps.

The S811+ offers an impressive array of advanced protective features. Not only are the protective features selectable, but many offer variable settings and adjustable time delays to ride through system discrepancies. Protective features may also be set to Warning status to avoid nuisance trips.

The S811+ has an easy to use Digital Interface Module (DIM) that allows the user to configure the device and to read system parameters and monitor system values. The DIM includes an LCD display and keypad to scroll through the various menus. The DIM allows the user to modify control parameters, enable or disable protections, set communication variables, monitor system parameters such as line voltages and currents, and access the fault queue.

The DIM can be removed from the S811+ and be remote mounted. Kits are available to door mount the DIM, enabling users to safely configure, commission, monitor and troubleshoot the system at the electrical panel without opening the enclosure door. This will help eliminate the possibility of an arc flash incident.

Digital Interface Module (DIM)

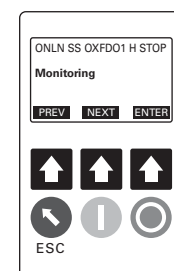

1

Communications

The S811+ is equipped with native Modbus RTU communication capabilities and may be connected to a variety of networks, including DeviceNet, Modbus TCP, EtherNet/IP and PROFIBUS using the C441 series communication modules for easy integration into any PLC or DCS system.

The modules come standard with four inputs and two relay outputs. C441 communication modules can also be used independently for standalone I/O applications.



C441 Communication Card Options

Designed for use with soft starters ...



Protocol	Catalog Number	Input Signal Type	S811+	General Purpose I/O ①	Mounting Options
Modbus RTU	C441NS	120 Vac	■	■	Standalone—DIN rail/panel mount
	C441PS	24 Vdc	■	■	Standalone—DIN rail/panel mount
DeviceNet	C441KS	120 Vac	■	■	Standalone—DIN rail/panel mount
	C441LS	24 Vdc	■	■	Standalone—DIN rail/panel mount
PROFIBUS	C441SS	120 Vac	■	■	Standalone—DIN rail/panel mount
	C441QS	24 Vdc	■	■	Standalone—DIN rail/panel mount
Modbus TCP, EtherNet/IP	C441U	120 Vac	■	■	Standalone—DIN rail/panel mount
	C441V	24 Vdc	■	■	Standalone—DIN rail/panel mount

Note: Refer to Volume 5—Motor Control and Protection, **CA08100006E**, tab 5.4 for additional details and **BR042002EN** brochure for C441 communication module accessories for overload relays and soft starters.

Recommended Power Supply	Catalog Number
85–264 Vac single-phase input, 24 Vdc output	PSG240E24RM
360–575 Vac three-phase input, 24 Vdc output	PSG240F24RM

Operation

Starting and Stopping Modes

The S811+ has a variety of starting and stopping methods to provide superior performance in the most demanding applications. The motor can be started in either voltage ramp start or current limit start mode. Kick start and soft stop are available within both starting modes. The user has the option to configure two independent start ramp profiles to accommodate variations in starting requirements.

Voltage Ramp Start

Provides a voltage ramp to the motor resulting in a constant torque increase. The most commonly used form of soft start, this start mode allows

you to set the initial torque value and the duration of the ramp to full voltage conditions. Bypass contactors close after ramp time.

- Adjustable initial torque 0–85% of locked rotor torque
- Adjustable ramp time 0.5–180 seconds (0.5–360 seconds with the S811+ Premium)

Starting Characteristics—Ramp Start

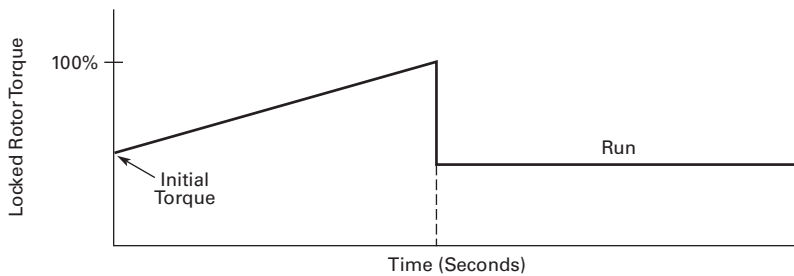

Note

① C441 standalone communication modules can be used as general purpose I/O. This allows a customer to monitor the status of any non-communicating product over the selected protocol by wiring fault or auxiliary contacts from that product to the C441 communication module on-board I/O.

Current Limit Start

Limits the maximum current available to the motor during the start phase. This mode of soft starting is used when it becomes necessary to limit the maximum starting current

due to long start times or to protect the motor. This start mode allows you to set the maximum starting current as a percentage of locked rotor current and the duration of

the current limit. Bypass contactors close after current limit time.

- Maximum current of 0–85% locked rotor current
- Adjustable ramp time 0.5–180 seconds (0.5–360 seconds with the S811+ Premium)

Starting Characteristics—Current Limit Start

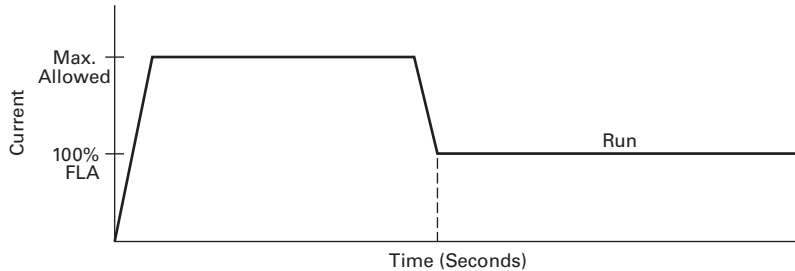

Kick Start

Selectable feature in both voltage ramp start and current limit start modes. Provides a current and torque “kick” for 0 to 2.0 seconds.

This provides greater initial current to develop additional torque to breakaway a high friction load.

- 0–85% of locked rotor torque
- 0–2.0 seconds duration

Starting Characteristics—Kick Start

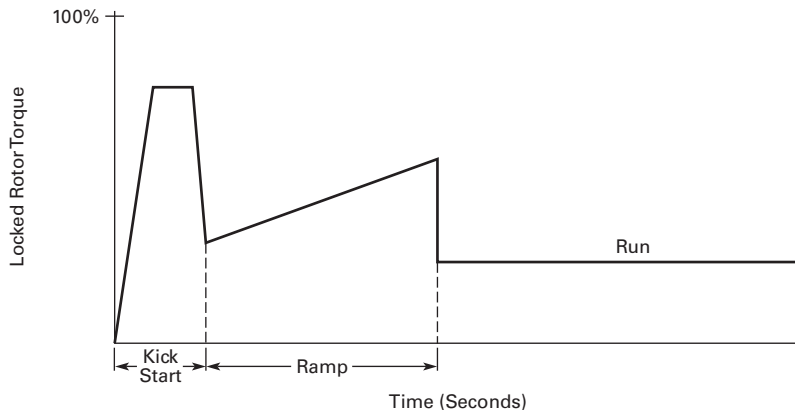

Soft Stop

Allows for a controlled stopping of a load. Used when a stop-time that is greater than the coast-to-stop

time is desired. Often used with high friction loads where a sudden stop may cause system or load damage.

- Stop time = 0–60 seconds

Starting Characteristics—Soft Stop

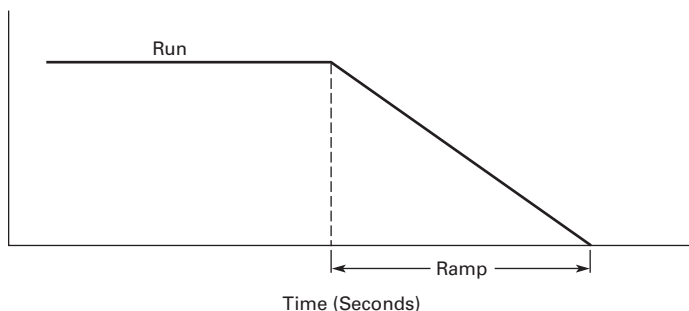

Edge and Level Sensing Control**Edge Sensing**

Edge sensing requires +24 Vdc power be momentarily applied to Control Terminal Block Pin 1 (with Terminal P at +24 Vdc) to initiate a start under all conditions. After a stop or fault occurs, the +24 Vdc must be removed, then reapplied to Terminal Pin 1 before another start can occur. This control configuration should be used when restarting of the motor after a fault or stop must be supervised manually or as a part of a control scheme. The cycling of +24 Vdc power to Terminal 1 Pin before starting is required regardless of the position of the auto reset switch on the DIM.

Level Sensing

Level sensing will enable a motor to restart after a fault is cleared without cycling +24 Vdc power to Terminal Pin 1 as long as:

- Terminal Pin P is supplied with +24 Vdc (to start from Control Terminal Block, Terminal Pin 3 must also be enabled)
- The auto reset switch on the DIM is set to enabled
- All faults have been reset

This control configuration should be used where it is desirable to restart a motor after a fault without additional manual or automatic control. An example of this condition would be on a remote pumping station where it is desirable to automatically restart a pump after a power outage without operator intervention.

Note: If the auto reset feature is used, CAUTION must be exercised to ensure that any restart occurs in a safe manner.

Features and Benefits

- Communication capabilities with various protocols
- The Digital Interface Module (DIM) provides an intuitive, easy-to-use human interface with powerful configuration capabilities to maximize system performance
- Door or device mounted DIM enables users to safely configure, commission, monitor and troubleshoot the system at the electrical panel without opening the enclosure door, eliminating the possibility of an arc flash incident
- System operating parameters can be monitored enterprise-wide through a communications network. Increase uptime by providing data for process management and preventive diagnostics
- Run internal bypass mode greatly reduces internal heating created by the greater power dissipation in the SCRs. Bypass contactor directly connects the motor to the line and improves system efficiency by reducing internal power losses
- Internal solid-state overload protection provides accurate current measurement and trip settings. Sophisticated algorithms solve a series of differential equations that model true motor heating and cooling, resulting in superior motor overload protection while minimizing nuisance trips. Advanced selectable protective features safeguard the motor and system against a variety of system faults
- Internal run bypass contactors and overload protection eliminate the need for additional devices, reducing enclosure sizes, minimizing installation and wiring time, and reducing overall assembly size and cost
- Wide range of overload FLA settings (31–100% of rated current) and a selectable trip class (5–30) offers users the flexibility to fine tune the starter to match specific application requirements
- Variable ramp times and torque control settings provide unlimited starting configurations, allowing for maximum application flexibility
- Kick-start feature enables soft starting of high friction loads
- Soft stop control for applications where an abrupt stop of the load is not acceptable
- The S811+ Premium with sophisticated pump control algorithms on both starting and stopping that minimize the pressure surges that cause water hammer. The pump control feature will maximize the life of the pump and piping systems while minimizing the downtime caused by system failure
- Six SCRs control all three motor phases, providing smooth acceleration and deceleration performance
- Soft acceleration and deceleration reduces wear on belts, gears, chains, clutches, shafts and bearings
- Reduce the peak inrush current's stress on the power system
- Manage peak starting torque to diminish mechanical system wear and damage
- 24 Vdc control voltage enhances personnel and equipment safety
- Removable, lockable control terminal block reduces maintenance costs. Also provides the opportunity for OEMs to reduce assembly and test costs by utilizing pre-assembled wire harnesses

Motor Wiring Configuration User Selectable Inline or Inside-the-Delta

Mains Motor Wiring Configuration is accomplished by simply selecting the required configuration from a menu. This feature allows adaptability from one configuration to another without any additional programming operations and reduces inventory levels by not having to stock both configurations.

Modbus Native Communications Protocol

Modbus RTU communications is now standard on all S811+ units. This allows users to quickly configure the unit for network communications using a common protocol. Adapters are available for users who prefer to use EtherNet/IP or Modbus TCP protocols.

Programmable Control Terminal Block Functionality

Four programmable terminals on the S811+ enable the user to expand functionality with options such as a second start ramp profile, externally triggered trip or warning functions, analog inputs, and others, in addition to the normal start, stop, reset, and so on, functions.

Second Start Ramp Profile Capability

A second start ramp profile may be configured for the soft starter. This profile is independent of the primary profile and retains all the parameter options such as start time and initial torques. With a signal at a terminal programmed for this feature, the second profile may be selected by a pushbutton station or a network.

Alarm-No-Trip Functionality

Some applications require the ability to effectively disable most protections with the intent of enabling the RVSS unit to control a motor under the most severe operating conditions characterized by current or voltage imbalances, high or low value deviations, or other fault conditions. This function causes the S811+ to ignore most fault trip conditions and continue operation of the application.

Digital Interface Module (DIM) Cloning

For OEMs or other users that desire to load identical parameter settings into multiple RVSS units, the DIM may be used to extract and duplicate parameter settings from one RVSS and loaded into other units, saving time, effort, and reducing chances for errors while programming.

Protective Features

All protective features can be configured, enabled or disabled with the DIM or through the communications network.

Motor Overload

The S811+ includes electronic overload protection as standard. The overload meets applicable requirements for a motor overload protective device. The overload protects the motor from over heat conditions with the use of sophisticated algorithms that model true motor heating, resulting in superior motor protection and fewer nuisance trips.

The S811+ calculates a thermal memory value based on the heat energy introduced into the motor during the start process. A 100% value represents the maximum safe internal temperature of the motor.

When the thermal memory value reaches 100%, an overload trip will occur removing power to the motor. Upon trip, the S811+ stores the calculated motor heating value and will not allow a motor re-start until the motor has a thermal memory value of less than 100%. This feature ensures the motor will not be damaged by repeated overload trip, reset and re-start cycles.

The thermal memory value can be monitored through the DIM or the communications network. The thermal memory value can be of great use in determining an impending overload trip condition. Alarms can be implemented in the process monitoring system warning of an impending trip before a trip occurs halting the process. Costly system downtime can be avoided.

The trip current is adjusted to match the specific application requirements by entering the motor nameplate full load current rating and trip class. The FLA parameter is adjustable from 32% to 100% of the unit's rated current. The overload trip class is adjustable from class 5 through class 30. The overload is ambient temperature compensated—meaning its trip characteristics will not vary with changes in ambient temperature. The overload protection can be enabled, disabled, or disabled on start.

Short Circuit

The use of a short-circuit protective device in coordination with the S811+ is required in branch motor circuits by most electrical codes. Short-circuit coordination ratings with both fuses and Eaton molded case circuit breakers are available providing customers with design flexibility. The S811+ has short-circuit coordination ratings as an open component, an enclosed starter, and in a motor control center.

External E-Stop

Emergency Stop functionality may be triggered from an external source. Removal of the 24 Vdc signal from a terminal configured for E-Stop will initiate an E-Stop action. The External E-Stop option is useful in applications where it is desirable to accomplish a motor shutdown in the event that an external condition(s) exist that will damage system components and/or product flows or operations.

External Trip

External Trip functionality may be triggered from an external source. Removal of the 24 Vdc signal from a terminal configured for External Trip will initiate an External Trip action. The External Trip option is useful in applications where it is desirable to accomplish a motor stop in the event that an external condition(s) exist that will damage system components and/or product flows or operations.

Fault Warning Functionality

Selected protection parameters may be assigned to provide a Fault Warning instead of a Fault Trip with user adjustable set points. When a Fault Warning condition is detected, the fault condition is reported via the DIM, network connection, or an auxiliary relay configured for this function. The soft starter remains in operation. At such time the fault condition no longer exists, the Fault Warning message will be extinguished.

External Warning

The S811+ will accept a Warning signal from an external source or device. In a fashion similar to the Fault Warning, the fault condition is reported via the DIM, network connection, or an auxiliary relay configured for this function. The soft starter remains in operation. At such time the fault condition no longer exists, the Fault Warning message will be extinguished.

Custom Fault/Warning Auxiliary Relays

Up to three fault and/or warning codes may be selected to operate an auxiliary relay configured to operate when any of these codes are detected. This option enables the user to provide external warnings or fault indications to increase monitoring effectiveness and to provide additional system control.

Motor Power

Motor Power can be not only be monitored, but trip levels can be adjusted to provide indications of system malfunctions or operating discrepancies. Both High and Low Power thresholds can be set to provide Fault Warning or Fault Trip functions. Additionally, fault delays times may be set to up to 60 seconds.

Analog Input

An input control terminal may be configured to accept a 0–20 mA DC signal with range scaling. This feature enables the S811+ to respond to an external device that may be monitoring a critical component or process and provides Fault Trip or Fault Warning capability to protect operating systems and processes.

Start Delay

Three start delay timers are available to enhance motor protection or to provide simple logic functions to coordinate motor control with other devices in the system. The timers will allow delays from 24 Vdc power up, receipt of a valid START command, or a delay in switch from one start ramp profile to another.

Jam

Excessive current and torque up to locked rotor levels can occur in a jam condition. The condition can result in stress and damage to the motor, load, mechanical system, and the electrical distribution system. Jam protection prevents the stress and damage from a jam during normal run. After the motor is in bypass, a current greater than 300% FLA setting will cause the starter to trip on a jam fault.

Stall

Excessive current and torque up to locked rotor levels can occur in a stall condition. The condition can lead to an overload trip and result in stress and damage to the motor, load, mechanical system, and the electrical distribution system. Stall protection prevents stress and damage to a motor that has not come up to speed during the soft start time. The S811+ will trip to protect the system in the event that the motor did not get to the rated speed in the defined soft start period. A current greater than 200% FLA at the end of the soft start period will cause the starter to trip on a stall fault.

Pole Over Temperature

High ambient temperatures, extended ramp times and high duty cycle conditions may cause the S811+ power pole conductors to reach a temperature that exceeds their thermal rating. The S811+ is equipped with sensors that monitor the temperature of the power poles. Over temperature protection occurs if the power pole's thermal capacity is exceeded. The soft starter will trip in over temperature conditions, preventing device failure.

Each power pole temperature value can be monitored through the DIM or the communications network. This feature can be of use in determining an impending over temperature trip condition.

When using a communications network, alarms can be implemented in the process monitoring system warning of an impending trip before the trip occurs, halting the process.

Phase Loss

Loss of a phase can cause a significant increase in the current drawn in the remaining two phases. Phase loss can lead to motor damage before an eventual overload trip occurs. Phase loss is typically an indication of a failure in the electrical distribution system. The S811+ will detect a phase loss and trip if any phase current drops below a preset value. The phase loss trip level is adjustable from 0% to 100% of the average of the other two phase levels with an adjustable trip delay of 0.1 to 60 seconds.

Phase Imbalance

Phase current or voltage imbalance can cause a significant increase in the current drawn in the remaining two phases. Phase imbalance can lead to motor damage before an eventual overload trip. Phase imbalance is typically an indication of a failure in the electrical distribution system or the motor. The S811+ will detect both current and voltage phase imbalances and trip if any phase becomes imbalanced as compared to the average of the other two phases.

The phase current imbalance trip level is adjustable from 0% to 100% of the average of the current in the other two phases with an adjustable trip delay of 0.1 to 60 seconds.

The phase voltage imbalance trip level is adjustable from 0% to 100% of the average of the voltage in the other two phases with an adjustable trip delay of 0.1 to 60 seconds.

Reset Mode

The S811+ can be set up for automatic or manual reset on trip. The manual reset mode requires the operator to physically press the RESET button located on the soft starter. The trip can be manually reset through the DIM or through the communications network. The trip can also be electrically reset by energizing a 24 Vdc input on the control terminal block.

The automatic reset mode allows the soft starter to be automatically reset as soon as the trip condition is no longer present. With the automatic reset mode, after the fault is no longer present, the motor will be restarted as soon as a valid start signal is present.

Phase Reversal

The S811+ can determine if the proper line phase sequence is present by default. The device will trip if the line phase sequence is something other than A-B-C. The S811+ can be configured to operate under reversed phase conditions (A-C-B).

Shorted SCR Detection

The S811+ monitors the operation of the power poles and will trip under a shorted SCR condition.

Open SCR Detection

The S811+ monitors the operation of the power poles and will trip under an open SCR condition.

Ground Fault Protection

The S811+ Premium and 690 V versions meet the IEC Ground Fault trip thresholds. Reference Application Note AP039007EN for more information.

Low Current

Low current conditions can be a result of a loss of load or a failure in the mechanical system. The S811+ has low current protection that will trip if the average rms current falls below a preset value. The low current protection can be programmed as a percent of motor FLA from 0% to 100%.

Low Voltage

Low voltage conditions can result from disturbances in the electrical power distribution system. Low voltage conditions can cause a malfunction and damage to electrical equipment. The S811+ has low voltage protection that will trip if the average rms voltage falls below a preset value. The low voltage protection can be programmed as a percent of nominal voltage from 1% to 99% with a trip delay of 0.1 to 60 seconds to accommodate short temporary voltage drops during the start process.

High Voltage

High voltage conditions can result from disturbances in the electrical power distribution system. High voltage conditions can cause malfunctions or failures of electrical equipment. The S811+ has high voltage protection that will trip if the average rms voltage is greater than a preset value. The high voltage protection can be programmed as a percent of nominal voltage from 101% to 120% with a trip delay of 0.1 to 60 seconds.

Monitoring Capabilities

The S811+ has an impressive array of system monitoring capabilities that allows users to access real time process and diagnostic data. This data can be viewed at the device with the DIM or through a communications network. Data over a communications network can provide valuable insight into the condition of the equipment and processes. Maintenance and production personnel can monitor critical operational and maintenance data from a central control station that can be located far away from the production facility. Process data can be monitored to determine system anomalies that may indicate a need for preventive maintenance or an impending failure. Adjustments made through the communications network can reduce costs by minimizing the time traveling to the location where the motor controls are located. When faults do occur, real time fault data can assist maintenance in troubleshooting and planning repair resources. Remote reset signals can be given to tripped devices without the need for manual intervention by maintenance personnel.

Average Line Current

Provides the average of the three-phase rms line currents in amps, accurate to within 2%. Current data can be used to indicate a need for maintenance. Increased currents in a fixed load application can indicate a reduction in system efficiencies and performance, signifying system maintenance is due.

Average Pole Current

Provides the average of the three-phase rms pole currents in amps, accurate to within 2%. The pole current is the current through the soft starter. The line and pole current will be identical in inline applications, and will differ in inside-the-delta applications.

Average Line Current as a % FLA

Provides the average rms line current as a percentage of the S811+ FLA setting.

Three-Phase Line Currents

Provides three rms phase line currents in amps, accurate to within 2%. Imbalances or changes in the relative phase current to one another can indicate anomalies in the motor or electrical distribution system.

Three-Phase Pole Currents

Provides three rms phase pole currents in amps, accurate to within 2%. The pole current is the current through the soft starter. The line and pole current will be identical in in-line applications, and will differ in inside-the-delta applications.

Three-Phase Line Voltages

Provides the individual rms three-phase line voltages. Imbalances or changes in the relative phase voltage to one another can indicate anomalies in the motor or electrical distribution system. Voltage can be used to monitor electrical distribution system performance. Warnings, alarms and system actions to low or high voltage conditions can be implemented.

Percent Thermal Memory

Provides the real time calculated thermal memory value. The S811+ calculates thermal memory value. A 100% value represents the maximum safe internal temperature of the motor. When the thermal memory value reaches 100%, an overload trip will occur, removing power to the motor.

The thermal memory value can be of great use in determining an impending overload trip condition. When using a communications network, alarms can be implemented in the process monitoring system warning of an impending trip before the trip occurs, halting the process. Costly system downtime can be avoided.

DC Control Voltage

Monitors level of the 24 Vdc control voltage. Fluctuations in control voltage can cause component malfunction and failure. System control voltage data can be used to implement warnings, alarms and system actions to low or high voltage conditions.

Pole Temperature

Increases in power pole temperature are caused by increases in ambient temperature, start/stop times and start duty cycles. Changes in pole temperatures represent a change in system operating conditions. Identifying unexpected operating conditions or changes can prompt maintenance and aid in process evaluation activities.

PCB Device Temperature

An increase in printed circuit board (PCB) device temperature is a strong indication of an increase in ambient temperature. High ambient temperature operation can be identified with the device temperature data. Device temperature increases can be due to undersized enclosures, failure of cooling fans or blocked venting. High operating temperatures will reduce the life of all electrical equipment in the enclosure.

Start Count

Start count data can be used to monitor system output, schedule preventative maintenance, identify system anomalies and identify changes in system operation.

Average Line Power

Provides the average of the three-phase line power in kilowatts, accurate to 5%. Power data may be used to monitor power transmitted to the load. Increased power demand may indicate degraded system components or connections. Additionally, such data is useful in determine power utilization in branch circuits consisting of multiple loads.

Power Factor

Provides the three-phase power factor value, accurate to 5%. The power factor of the circuit may be used to identify circuit conditions that may need to be corrected due to low power factor indications. Low circuit power factor can indicate improper or degraded components.

Diagnostics

Fault Queue

Current fault and a fault queue containing the last nine system faults can be read through the DIM or communications network. Fault identification can minimize troubleshooting time and cost, and prevent arc flash incidents. The fault queue can be remotely accessed through a communications network to assist in planning maintenance resources. Thirty (30) different faults can be identified by the S811+.

Control Status

The S811+ provides data that represents system conditions that can be read through the DIM or the communications network. This data identifies the status of the system and the control commands the system is requesting of the S811+. This can be used for advanced troubleshooting and system integration activities.

Breaker Status

The S811+ has provisions to read and display circuit breaker status. Eaton communicating cover control or other communicating protective device is required to take advantage of this feature.

Standards and Certifications

- IEC 60947-4-2
- EN 60947-4-2
- UL listed (NMFT-E202571) S811+N37... through S811+V85...
- UL recognized (NMFT2) S811+V10...
- CE marked
- CSA certified (3211 06)
- CSA elevator (2411 01)



Instructional Leaflets

- User manual MN03900001E
- Outline drawings:
 - S811+N...: 10-8574
 - S811+R...: 10-8575
 - S811+T...: 10-8576
 - S811+U...: 10-8857
 - S811+V...: 10-8577

Catalog Number Selection

S811+ Open Soft Starters ①

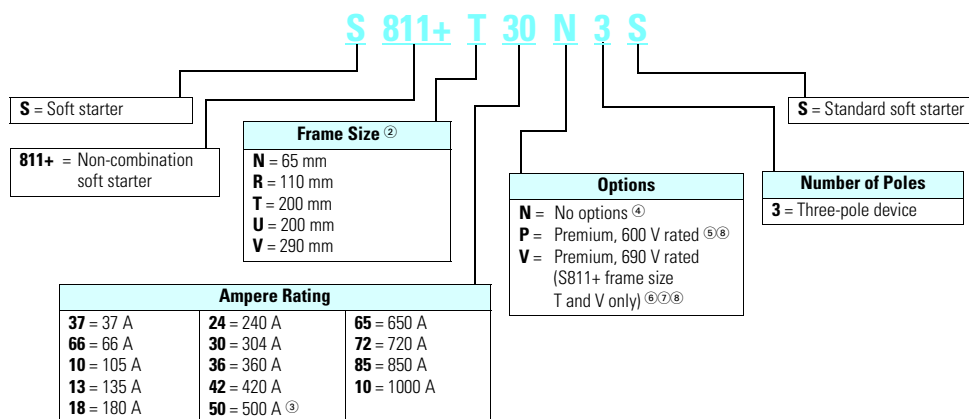

Notes

- ① All units require a 24 Vdc power supply found on catalog **Page V6-T1-110**, or equivalent.
- ② S811+T..., S811+U..., and S811+V... units require lug kits found on **Page V6-T1-110**.
- ③ S811+U50... unit does not have IEC certification.
- ④ Level/Edge Sense, Inline or Inside-the-Delta wiring configuration.
- ⑤ Level/Edge Sense, Inline or Inside-the-Delta wiring configuration, pump control and extended ramp.
- ⑥ Not available in S811+U....
- ⑦ Level/Edge Sense, Inline wiring configuration, pump control, extended ramp.
- ⑧ Ground fault protection included.

Product Selection

Standard Duty Ratings

Starting Method	Ramp Current % of FLA	Ramp Time Seconds	Starts per Hour	Ambient Temperature
Soft start	300%	30 sec.	3	50 °C
Full voltage	500%	10 sec.	3	50 °C
Wye-delta	350%	20 sec.	3	50 °C
80% RVAT	480%	20 sec.	2	50 °C
65% RVAT	390%	20 sec.	3	50 °C
50% RVAT	300%	20 sec.	4	50 °C

Motor applications and customer needs come in many different varieties. With the standard and severe duty rating tables, we have attempted to provide

guidelines on what the soft starter is capable of. If the application falls under these categories, you can use these charts. For other applications, or when a

question arises, consult with your local Eaton representative or call our Technical Resource Center.

S811+



Standard Duty—15 Second Ramp, 300% Current Limit at 50 °C, Inline Connection

Rated Current	Three-Phase Motors kW Rating (50 Hz)			hp Rating (60 Hz)				575–690 V				Catalog Number ^①
	230 V	380–400 V	440 V	200 V		230 V		460 V		1.0SF		
Frame Size N												
37	10	18.5	18.5	10	10	10	10	25	20	30	30	S811+N37N3S
66	18.5	30	37	20	15	20	20	50	40	60	50	S811+N66N3S
Frame Size R												
105	30	55	59	30	25	40	30	75	60	100	75	S811+R10N3S
135	40	63	80	40	30	50	40	100	75	125	100	S811+R13N3S
Frame Size T												
180	51	90	110	60	50	60	60	150	125	150	150	S811+T18N3S
240	75	110	147	75	60	75	75	200	150	200	200	S811+T24N3S
304	90	160	185	100	75	100	100	250	200	300	250	S811+T30N3S
Frame Size U												
360	110	185	220	125	100	150	125	300	250	350	300	S811+U36N3S
420	129	220	257	150	125	175	150	350	300	450	350	S811+U42N3S
500	150	257	300	150	150	200	150	400	350	500	450	S811+U50N3S^②
Frame Size V												
360	110	185	220	125	100	150	125	300	250	350	300	S811+V36N3S
420	129	220	257	150	125	175	150	350	300	450	350	S811+V42N3S
500	150	257	300	150	150	200	150	400	350	500	450	S811+V50N3S
650	200	355	425	250	200	250	200	500	450	600	500	S811+V65N3S
720	220	400	450	—	—	300	250	600	500	700	600	S811+V72N3S
850	257	475	500	—	—	350	300	700	600	900	700	S811+V85N3S
1000	277	525	550	—	—	400	350	800	700	900	800	S811+V10N3S

Notes

- ① Replace N3S with P3S for premium/pump option.
- ② S811+U50... rating does not have IEC certification.

Severe Duty

Severe Duty Ratings

Starting Method	Ramp Current % of FLA	Ramp Time Seconds	Starts per Hour	Ambient Temperature
Soft start	450%	30 sec.	4	50 °C
Full voltage	500%	10 sec.	10	50 °C
Wye-delta	350%	65 sec.	3	50 °C
80% RVAT	480%	25 sec.	4	50 °C
65% RVAT	390%	40 sec.	4	50 °C
50% RVAT	300%	60 sec.	4	50 °C

Severe duty ratings are defined as any combination of parameters that exceed the standard duty ratings where

the ramp time is over 30 seconds, and/or the number of starts per hour exceeds 4, and/or the current limit set is

over 300%. *Example:* 35-second ramp, 5 starts per hour, 350% current limit at 40 °C ambient.

S811+



Severe Duty—30 Second Ramp and/or 450% Current Limit at 50 °C, Inline Connection

Rated Current	Three-Phase Motors kW Rating (50 Hz)			hp Rating (60 Hz)				575–690 V				Catalog Number ^①
	230 V	380–400 V	440 V	200 V		230 V		460 V		575–690 V		
				1.0SF	1.15SF	1.0SF	1.15SF	1.0SF	1.15SF	1.0SF	1.15SF	
Frame Size N												
22	5.5	10	11	5	5	7-1/2	5	15	10	20	15	S811+N37N3S
42	11	18.5	22	10	10	15	10	30	25	40	30	S811+N66N3S
Frame Size R												
65	15	30	33	15	15	20	15	50	40	50	50	S811+R10N3S
80	22	40	45	25	20	30	25	60	50	75	60	S811+R13N3S
Frame Size T												
115	33	59	63	30	30	40	30	75	75	100	100	S811+T18N3S
150	45	80	90	50	40	50	50	100	100	150	125	S811+T24N3S
192	55	100	110	60	50	75	60	150	125	200	150	S811+T30N3S
Frame Size U												
240	75	110	147	75	60	75	75	200	150	200	200	S811+U36N3S
305	90	160	185	100	75	100	100	250	200	300	250	S811+U42N3S
365	110	185	220	125	100	150	125	300	250	350	300	S811+U50N3S^②
Frame Size V												
240	75	110	147	75	60	75	75	200	150	200	200	S811+V36N3S
305	90	160	185	100	75	100	100	250	200	300	250	S811+V42N3S
365	110	185	220	125	100	150	125	300	250	350	300	S811+V50N3S
420	129	220	257	150	125	150	150	350	300	450	350	S811+V65N3S
480	147	257	295	150	150	200	150	400	350	500	450	S811+V72N3S
525	160	280	335	150	150	200	150	450	350	500	450	S811+V85N3S
575	172	303	370	200	150	250	200	500	450	600	500	S811+V10N3S

Notes

- ① Replace N3S with P3S for premium/pump option.
- ② S811+U50... rating does not have IEC certification.

Inside-the-Delta Standard Duty Ratings

S811+



Standard Duty— 15 Second Ramp, 300% Current Limit at 40 °C, Inside-the-Delta Connection

Rated Motor Line Current	Three-Phase Motor kW Rating (50 Hz)			hp Rating (60 Hz)								Catalog Number ^①
				200 V		230 V		460 V		575 V		
	230 V	380–400 V	440 V	1.0SF	1.15SF	1.0SF	1.15SF	1.0SF	1.15SF	1.0SF	1.15SF	
Frame Size N												
65	10	18.5	18.5	15	15	15	15	40	30	50	50	S811+R37N3S
114	18.5	30	37	30	25	30	30	75	60	100	75	S811+R66N3S
Frame Size R												
182	30	55	59	50	40	60	50	125	100	150	125	S811+R10N3S
234	40	63	80	60	50	75	60	150	125	200	150	S811+R13N3S
Frame Size T												
311	51	90	110	100	75	100	100	250	200	250	250	S811+T18N3S
415	75	110	147	125	100	125	125	300	250	300	300	S811+T24N3S
526	90	160	185	150	125	150	150	400	300	400	400	S811+T30N3S
Frame Size U												
623	110	185	220	200	150	250	200	450	400	550	450	S811+U36N3S
727	129	220	257	250	200	300	250	550	450	700	550	S811+U42N3S
865	150	257	300	250	250	300	250	600	550	750	700	S811+U50N3S ^{②③}
Frame Size V												
623	110	185	220	200	150	250	200	450	400	550	450	S811+V36N3S
727	129	220	257	250	200	300	250	550	450	700	550	S811+V42N3S
865	150	257	300	250	250	300	250	600	550	750	700	S811+V50N3S
1125	200	355	425	400	300	400	300	750	700	900	750	S811+V65N3S
1246	—	—	—	—	—	—	—	—	—	—	—	S811+V72N3S
1471	—	—	—	—	—	—	—	—	—	—	—	S811+V85N3S
—	—	—	—	—	—	—	—	—	—	—	—	S811+V10N3S

Notes

- ① Replace N3S with P3S for premium/pump option.
- ② S811+U50... unit does not have IEC certification.
- ③ 15 sec. start, 300% inrush, 40 °C, 1 start every 15 minutes. If these start parameters are exceeded, please refer to S811+V50... Catalog numbers also represent P3S and V3S units.

Inside-the-Delta Severe Duty Ratings

Severe duty ratings are defined as any combination of parameters that exceed the standard duty ratings where the ramp time is over 30 seconds, and/or the number of starts per hour exceeds 4, and/or the current limit set is over 300%.

Example: 35-second ramp, 5 starts per hour 350% current limit at 40 °C ambient.

S811+



Severe Duty—30 Second Ramp and/or 450% Current Limit at 50 °C, Inside-the-Delta Connection

Rated Motor Line Current	Three-Phase Motor												Catalog Number ①
	kW Rating (50 Hz)			hp Rating (60 Hz)									
	230 V	380–400 V	440 V	200 V		230 V		460 V		575 V			
			1.0SF	1.15SF	1.0SF	1.15SF	1.0SF	1.15SF	1.0SF	1.15SF			
Frame Size N													
39	5.5	10	11	7-1/2	7-1/2	10	7-1/2	25	15	30	25	S811+N37N3S	
73	11	18.5	22	15	15	25	15	50	40	60	50	S811+N66N3S	
Frame Size R													
111	15	30	33	25	25	30	25	75	60	75	75	S811+R10N3S	
138	22	40	45	40	30	50	40	100	75	120	100	S811+R13N3S	
Frame Size T													
199	33	59	63	50	50	60	50	125	125	150	150	S811+T18N3S	
257	45	80	90	75	60	75	75	150	150	250	200	S811+T24N3S	
324	55	100	110	100	75	100	100	250	200	300	250	S811+T30N3S	
Frame Size U													
415	75	110	147	125	100	125	125	300	250	300	300	S811+U36N3S	
526	90	160	185	150	120	150	150	400	300	450	400	S811+U42N3S	
623	110	185	220	200	150	250	200	450	400	550	450	S811+U50N3S ②	
Frame Size V													
415	75	110	147	125	100	125	125	300	250	300	300	S811+V36N3S	
526	90	160	185	150	120	150	150	400	300	450	400	S811+V42N3S	
623	110	185	220	200	150	250	200	450	400	550	450	S811+V50N3S	
727	129	220	257	250	200	250	250	550	450	700	550	S811+V65N3S	
816	147	257	295	250	250	300	250	600	550	750	700	S811+V72N3S	
908	160	280	335	250	250	300	250	700	550	750	700	S811+V85N3S	
—	—	—	—	—	—	—	—	—	—	—	—	S811+V10N3S	

Notes

- ① Replace N3S with P3S for premium/pump option.
- ② S811+U50... unit does not have IEC certification.

Accessories

Lug Kits

S811+T..., S811U... and S811+V... soft starters each have different lug options based on your wiring needs. Each lug kit contains three lugs that can be mounted on either the load or line side.

Lug Kit



Lug Kits

S811+ Catalog Number	Description	Kits Required	Catalog Number
S811+T..., S811+U...	2 cable connections, 4 AWG to 1/0 cable	2	EML22
	1 cable connection, 4/0 to 500 kcmil cable		EML23
	2 cable connections, 4/0 to 500 kcmil cable		EML24
	1 cable connection, 2/0 to 300 kcmil cable		EML25
	2 cable connections, 2/0 to 300 kcmil cable		EML26
S811+V...	2 cable connections, 4/0 to 500 kcmil cable	2	EML28
	4 cable connections, 4/0 to 500 kcmil cable		EML30
	6 cable connections, 4/0 to 500 kcmil cable		EML32
	4 cable connections, 2/0 to 300 kcmil cable		EML33

Power Supplies

24 Vdc power supply that can be used with the S811+ SSRV or as a stand-alone device.

Power Supplies

Description	Catalog Number
85–264 Vac input 24 Vdc output	PSG240E
360–575 Vac input 24 Vdc output	PSG240F
600 Vac input 24 Vdc output	PSS55D

Lug Cover Kits

Replacement covers for the S811+T..., S811+U... and S811+V... soft starters are available in case of damage to the existing covers.

Lug Cover Kits

Description	Catalog Number
Lug cover S811+T..., S811+U...	EML27
Lug cover S811+V...	EML34

IP20 Kits

IP20 Kits

Description	Catalog Number
S811+N...	SS-IP20-N
S811+R...	SS-IP20-R
S811+T... and S811+U...	SS-IP20-TU
S811+V...	SS-IP20-V

Surge Suppressors

The surge suppressor can mount on either the line or load side of the soft starter. It is designed to clip the line voltage (or load side induced voltage).

Surge Suppressor



Surge Suppressors

Description	Catalog Number
600 V MOV for S811+... units	EMS39
690 V MOV for S811+... units [Ⓢ]	EMS41

Note

[Ⓢ] S811+T... only.

Mounting Plates

The mounting plates are designed to help make it easy to install or retrofit the soft starter into enclosures and MCCs. The soft starter can be mounted onto the plate prior to installation. The mounting plate is designed with tear drop mounting holes for easier installation.

Mounting Plates

Description	Catalog Number
S811+N...	EMM13N
S811+R...	EMM13R
S811+T... and S811+U...	EMM13T
S811+V...	EMM13V

Vibration Plates

The vibration plates allow the soft starter to be applied in high shock and vibration applications. The vibration plate allows vibration up to 5g and shock in up to 40g. The soft starter is mounted onto the vibration plate prior to installation in the panel.

Vibration Plates

Description	Catalog Number
S811+N...	EMM14N
S811+R...	EMM14R
S811+T... and S811+U...	EMM14T
S811+V...	EMM14V

Adapter Plates

The adapter plate allows customers to retrofit a S811+V... soft starter with the S811+U... soft starter.

Adapter Plates

Description	Catalog Number
Adapter plates	EMM13U

Control Wire Connector

Control Wire Connector

Description	Catalog Number
12-pin, 5 mm pitch connector for control wiring	EMA75

Digital Interface Module

The Digital Interface Module (DIM) is available as a replacement part.

DIM

Description	Catalog Number
Blank cover (filler)	EMA68
DIM for standard unit	EMA91
Panel mounting kit	
3 ft cable	EMA69A
5 ft cable	EMA69B
8 ft cable	EMA69C
10 ft cable	EMA69D

Options

S811+ Premium

In addition to what is already there in the S811+ standard, these devices offer pump control and extended ramp functions.

S811+ Premium

Current Range	Catalog Number
11–37	S811+N37P3S
20–66	S811+N66P3S
32–105	S811+R10P3S
42–135	S811+R13P3S
56–180	S811+T18P3S
75–240	S811+T24P3S
95–304	S811+T30P3S
112–360	S811+U36P3S
131–420	S811+U42P3S
156–500	S811+U50P3S ①
112–360	S811+V36P3S
131–420	S811+V42P3S
156–500	S811+V50P3S
203–650	S811+V65P3S
225–720	S811+V72P3S
265–850	S811+V85P3S
312–1000	S811+V10P3S

Note

① S811+U50... unit does not have IEC certification.

S811+ Premium 690 V Option

In addition to what is already there in S811+ standard, this product offers 690 V, pump control and extended ramp functions.

S811+ Premium 690 V Option

Current Range	Catalog Number
56–180	S811+T18V3S
75–240	S811+T24V3S
95–304	S811+T30 V3S
112–360	S811+V36V3S
131–420	S811+V42V3S
156–500	S811+V50 V3S
203–650	S811+V65V3S
225–720	S811+V72V3S
265–850	S811+V85V3S

Cooling Fan Kit

The EMM18 cooling fan kit mounts on either side of any frame size S811+ soft starter to provide additional printed circuit board cooling in high ambient operating temperatures.

Cooling Fan Kit

Description	Catalog Number
Fan kit	EMM18

Technical Data and Specifications

Soft Starters—S811+

Description	S811+N37...	S811+N66...	S811+R10+...	S811+R13...
Max. current capacity	37	66	105	135
FLA range	11–37	20–66	32–105	42–135
General Information				
Bypass mechanical lifespan	10M	10M	10M	10M
Insulating voltage U _i	660 V	660 V	660 V	660 V
Ramp time range	0.5–180 seconds (0.5–360 seconds S811+ Premium)	0.5–180 seconds (0.5–360 seconds S811+ Premium)	0.5–180 seconds (0.5–360 seconds S811+ Premium)	0.5–180 seconds (0.5–360 seconds S811+ Premium)
Resistance to vibration	3 g	3 g	3 g	3 g
Resistance to shock	15 g	15 g	15g	15 g
Electrical Information				
Operating voltage	200–600 V	200–600 V	200–600 V	200–600 V
Operating frequency	47–63 Hz	47–63 Hz	47–63 Hz	47–63 Hz
Overload setting	30–100%	30–100%	30–100%	30–100%
Trip class	5, 10, 20 and 30	5, 10, 20 and 30	5, 10, 20 and 30	5, 10, 20 and 30
Cabling Capacity (IEC 947)				
Number of conductors	1	1	1	1
Wire sizes	14–2	14–2	14–4/0	14–4/0
Type of connectors	Box lug	Box lug	Box lug	Box lug
Control Wiring (12-Pin)				
Wire sizes in AWG	22–14	22–14	22–14	22–14
Number of conductors (stranded)	2 (or one AWG 12)	2 (or one AWG 12)	2 (or one AWG 12)	2 (or one AWG 12)
Torque requirements in lb-in	3.5	3.5	3.5	3.5
Solid, stranded or flexible max. size in mm ²	3.31	3.31	3.31	3.31
Control Power Requirements				
Voltage range (24V ±10%)	21.6–26.4	21.6–26.4	21.6–26.4	21.6–26.4
Steady-state current amps	1.0	1.0	1.0	1.0
Inrush current amps	10	10	10	10
Ripple	1%	1%	1%	1%
Relays (1) Class A and C				
Voltage AC—maximum	240	240	240	240
Voltage DC—maximum	120	120	120	120
Amps—maximum	3	3	3	3
Environment				
Temperature—operating	–30 ° to 50 °C (no derating) consult factory for operation >50 °C	–30 ° to 50 °C (no derating) consult factory for operation >50 °C	–30 ° to 50 °C (no derating) consult factory for operation >50 °C	–30 ° to 50 °C (no derating) consult factory for operation >50 °C
Temperature—storage	–50 ° to 70 °C	–50 ° to 70 °C	–50 ° to 70 °C	–50 ° to 70 °C
Altitude	<2000 m—consult factory for operation >2000 m	<2000 m—consult factory for operation >2000 m	<2000 m—consult factory for operation >2000 m	<2000 m—consult factory for operation >2000 m
Humidity	<95% noncondensing	<95% noncondensing	<95% noncondensing	<95% noncondensing
Operating position	Any	Any	Any	Any
Pollution degree IEC947-1	3	3	3	3
Impulse withstand voltage IEC947-4-1	6000 V	6000 V	6000 V	6000 V

Soft Starters—S811+, continued

Description	S811+T18...	S811+T24...	S811+T30...	S811+U36...
Max. current capacity	180	240	304	360
FLA range	56–180	75–240	95–304	112–360
General Information				
Bypass mechanical lifespan	10M	10M	10M	10M
Insulating voltage U_i	660 V	660 V	660 V	660 V
Ramp time range	0.5–180 seconds (0.5–360 seconds S811+ Premium)	0.5–180 seconds (0.5–360 seconds S811+ Premium)	0.5–180 seconds (0.5–360 seconds S811+ Premium)	0.5–180 seconds (0.5–360 seconds S811+ Premium)
Resistance to vibration	3 g	3 g	3 g	3 g
Resistance to shock	15 g	15 g	15 g	15 g
Electrical Information				
Operating voltage	200–600 V	200–600 V	200–600 V	200–600 V
Operating frequency	47–63 Hz	47–63 Hz	47–63 Hz	47–63 Hz
Overload setting	30–100%	30–100%	30–100%	30–100%
Trip class	5, 10, 20 and 30	5, 10, 20 and 30	5, 10, 20 and 30	5, 10, 20 and 30
Cabling Capacity (IEC 947)				
Number of conductors	1 or 2	1 or 2	1 or 2	1 or 2
Wire sizes	4 AWG to 500 kcmil	4 AWG to 500 kcmil	4 AWG to 500 kcmil	4 AWG to 500 kcmil
Type of connectors	Add-on lug kit	Add-on lug kit	Add-on lug kit	Add-on lug kit
Control Wiring (12-Pin)				
Wire sizes in AWG	22–14	22–14	22–14	22–14
Number of conductors (stranded)	2 (or one AWG 12)	2 (or one AWG 12)	2 (or one AWG 12)	2 (or one AWG 12)
Torque requirements in lb-in	3.5	3.5	3.5	3.5
Solid, stranded or flexible max. size in mm ²	3.31	3.31	3.31	3.31
Control Power Requirements				
Voltage range (24V ±10%)	21.6–26.4	21.6–26.4	21.6–26.4	21.6–26.4
Steady-state current amps	1.0	1.0	1.0	1.0
Inrush current amps	10	10	10	10
Ripple	1%	1%	1%	1%
Relays (1) Class A and C				
Voltage AC—maximum	240	240	240	240
Voltage DC—maximum	120	120	120	120
Amps—maximum	3	3	3	3
Environment				
Temperature—operating	–30 ° to 50 °C (no derating) consult factory for operation >50 °C	–30 ° to 50 °C (no derating) consult factory for operation >50 °C	–30 ° to 50 °C (no derating) consult factory for operation >50 °C	–30 ° to 50 °C (no derating) consult factory for operation >50 °C
Temperature—storage	–50 ° to 70 °C	–50 ° to 70 °C	–50 ° to 70 °C	–50 ° to 70 °C
Altitude	<2000 m—consult factory for operation >2000 m	<2000 m—consult factory for operation >2000 m	<2000 m—consult factory for operation >2000 m	<2000 m—consult factory for operation >2000 m
Humidity	<95% noncondensing	<95% noncondensing	<95% noncondensing	<95% noncondensing
Operating position	Any	Any	Any	Any
Pollution degree IEC947-1	3	3	3	3
Impulse withstand voltage IEC947-4-1	6000 V	6000 V	6000 V	6000 V

Soft Starters—S811+, continued

Description	S811+U42...	S811+U50... ^①	S811+V36...	S811+V42...
Max. current capacity	420	500	360	420
FLA range	131–420	156–500	112–360	131–420
General Information				
Bypass mechanical lifespan	10M	10M	10M	10M
Insulating voltage U _i	660 V	660 V	660 V	660 V
Ramp time range	0.5–180 seconds (0.5–360 seconds S811+ Premium)	0.5–180 seconds (0.5–360 seconds S811+ Premium)	0.5–180 seconds (0.5–360 seconds S811+ Premium)	0.5–180 seconds (0.5–360 seconds S811+ Premium)
Resistance to vibration	3 g	3 g	3 g	3 g
Resistance to shock	15 g	15 g	15 g	15 g
Electrical Information				
Operating voltage	200–600 V	200–600 V	200–600 V	200–600 V
Operating frequency	47–63 Hz	47–63 Hz	47–63 Hz	47–63 Hz
Overload setting	30–100%	30–100%	30–100%	30–100%
Trip class	5, 10, 20 and 30	5, 10, 20 and 30	5, 10, 20 and 30	5, 10, 20 and 30
Cabling Capacity (IEC 947)				
Number of conductors	1 or 2	1 or 2	2, 4 or 6	2, 4 or 6
Wire sizes	4 AWG to 500 kcmil	4 AWG to 500 kcmil	2/0 to 500 kcmil	2/0 to 500 kcmil
Type of connectors	Add-on lug kit	Add-on lug kit	Add-on lug kit	Add-on lug kit
Control Wiring (12-Pin)				
Wire sizes in AWG	22–14	22–14	22–14	22–14
Number of conductors (stranded)	2 (or one AWG 12)	2 (or one AWG 12)	2 (or one AWG 12)	2 (or one AWG 12)
Torque requirements in lb-in	3.5	3.5	3.5	3.5
Solid, stranded or flexible max. size in mm ²	3.31	3.31	3.31	3.31
Control Power Requirements				
Voltage range (24V ±10%)	21.6–26.4	21.6–26.4	21.6–26.4	21.6–26.4
Steady-state current amps	1.0	1.0	1.4	1.4
Inrush current amps	10	10	10	10
Ripple	1%	1%	1%	1%
Relays (1) Class A and C				
Voltage AC—maximum	240	240	240	240
Voltage DC—maximum	120	120	120	120
Amps—maximum	3	3	3	3
Environment				
Temperature—operating	–30 ° to 50 °C (no derating) consult factory for operation >50 °C	–30 ° to 50 °C (no derating) consult factory for operation >50 °C	–30 ° to 50 °C (no derating) consult factory for operation >50 °C	–30 ° to 50 °C (no derating) consult factory for operation >50 °C
Temperature—storage	–50 ° to 70 °C	–50 ° to 70 °C	–50 ° to 70 °C	–50 ° to 70 °C
Altitude	<2000 m—consult factory for operation >2000 m	<2000 m—consult factory for operation >2000 m	<2000 m—consult factory for operation >2000 m	<2000 m—consult factory for operation >2000 m
Humidity	<95% noncondensing	<95% noncondensing	<95% noncondensing	<95% noncondensing
Operating position	Any	Any	Any	Any
Pollution degree IEC947-1	3	3	3	3
Impulse withstand voltage IEC947-4-1	6000 V	6000 V	6000 V	6000 V

Note

① S811+U50... unit does not have IEC certification.

Soft Starters—S811+, continued

Description	S811+V50...	S811+V65...	S811+V72...	S811+V85...	S811+V10... ^①
Max. current capacity	500	650	720	850	1000
FLA range	156–500	203–650	225–720	265–580	320–1000
General Information					
Bypass mechanical lifespan	10M	10M	10M	10M	10M
Insulating voltage U _i	660 V	660 V	660 V	660 V	660 V
Ramp time range	0.5–180 seconds (0.5–360 seconds S811+ Premium)	0.5–180 seconds (0.5–360 seconds S811+ Premium)	0.5–180 seconds (0.5–360 seconds S811+ Premium)	0.5–180 seconds (0.5–360 seconds S811+ Premium)	0.5–180 seconds (0.5–360 seconds S811+ Premium)
Resistance to vibration	3 g	3 g	3 g	3 g	3 g
Resistance to shock	15 g	15 g	15 g	15 g	15 g
Electrical Information					
Operating voltage	200–600 V	200–600 V	200–600 V	200–600 V	200–600 V
Operating frequency	47–63 Hz	47–63 Hz	47–63 Hz	47–63 Hz	47–63 Hz
Overload setting	30–100%	30–100%	30–100%	30–100%	30–100%
Trip class	5, 10, 20 and 30	5, 10, 20 and 30	5, 10, 20 and 30	5, 10, 20 and 30	5, 10, 20 and 30
Cabling Capacity (IEC 947)					
Number of conductors	2, 4 or 6	2, 4 or 6	2, 4 or 6	2, 4 or 6	2, 4 or 6
Wire sizes	2/0 to 500 kcmil	2/0 to 500 kcmil	2/0 to 500 kcmil	2/0 to 500 kcmil	2/0 to 500 kcmil
Type of connectors	Add-on lug kit	Add-on lug kit	Add-on lug kit	Add-on lug kit	Add-on lug kit
Control Wiring (12-Pin)					
Wire sizes in AWG	22–14	22–14	22–14	22–14	22–14
Number of conductors (stranded)	2 (or one AWG 12)	2 (or one AWG 12)	2 (or one AWG 12)	2 (or one AWG 12)	2 (or one AWG 12)
Torque requirements in lb-in	3.5	3.5	3.5	3.5	3.5
Solid, stranded or flexible max. size in mm ²	3.31	3.31	3.31	3.31	3.31
Control Power Requirements					
Voltage range (24V ±10%)	21.6–26.4	21.6–26.4	21.6–26.4	21.6–26.4	21.6–26.4
Steady-state current amps	1.4	1.4	1.4	1.4	1.4
Inrush current amps	10	10	10	10	10
Ripple	1%	1%	1%	1%	1%
Relays (1) Class A and C					
Voltage AC—maximum	240	240	240	240	240
Voltage DC—maximum	120	120	120	120	120
Amps—maximum	3	3	3	3	3
Environment					
Temperature—operating	–30 ° to 50 °C (no derating) consult factory for operation >50 °C	–30 ° to 50 °C (no derating) consult factory for operation >50 °C	–30 ° to 50 °C (no derating) consult factory for operation >50 °C	–30 ° to 50 °C (no derating) consult factory for operation >50 °C	–30 ° to 50 °C (no derating) consult factory for operation >50 °C
Temperature—storage	–50 ° to 70 °C	–50 ° to 70 °C	–50 ° to 70 °C	–50 ° to 70 °C	–50 ° to 70 °C
Altitude	<2000 m—consult factory for operation >2000 m	<2000 m—consult factory for operation >2000 m	<2000 m—consult factory for operation >2000 m	<2000 m—consult factory for operation >2000 m	<2000 m—consult factory for operation >2000 m
Humidity	<95% noncondensing	<95% noncondensing	<95% noncondensing	<95% noncondensing	<95% noncondensing
Operating position	Any	Any	Any	Any	Any
Pollution degree IEC947-1	3	3	3	3	3
Impulse withstand voltage IEC947-4-1	6000 V	6000 V	6000 V	6000 V	6000 V

Note

① UR recognized product.

1

Wiring Diagrams

Line Connected Soft Starter

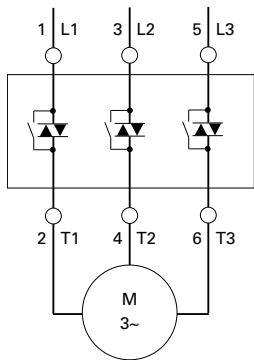

Inside-the-Delta Connected Soft Starter for a 6-Lead Motor

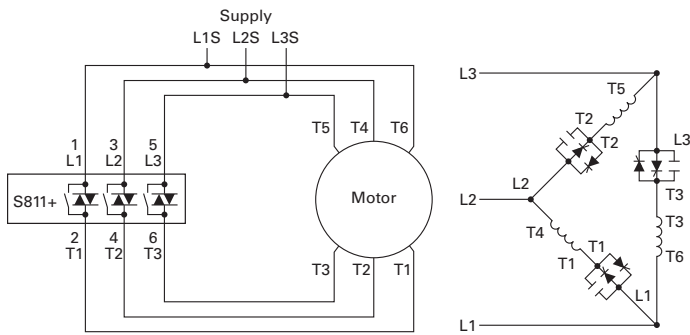

Inside-the-Delta Connected Soft Starter for a 12-Lead Low Voltage Motor

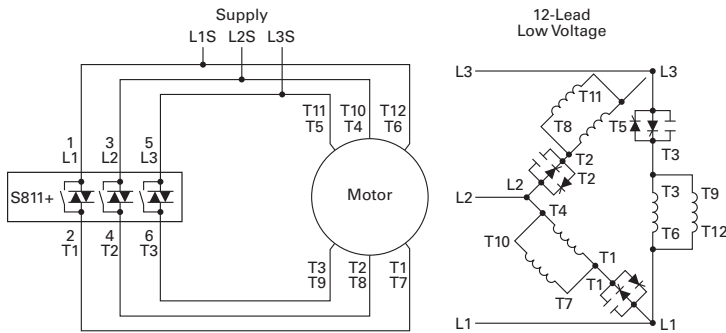

Inside-the-Delta Connected Soft Starter for a 12-Lead High Voltage Motor

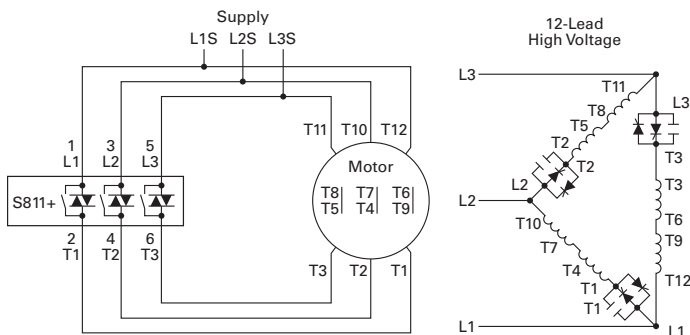

Dimensions

Approximate Dimensions in Inches (mm)

Soft Starters—S811+

Catalog Number ^①	W	H	D	Weight in lb (kg)
S811+N37N3S	2.66 (67.6)	7.37 (187.2)	6.45 (163.9)	5.8 (2.6)
S811+N66N3S	2.66 (67.6)	7.37 (187.2)	6.45 (163.9)	5.8 (2.6)
S811+R10N3S	4.38 (111.3)	7.92 (201.1)	6.64 (168.6)	10.5 (4.8)
S811+R13N3S	4.38 (111.3)	7.92 (201.1)	6.64 (168.6)	10.5 (4.8)
S811+T18N3S	7.65 (194.4)	12.71 (322.9)	6.47 (164.4)	48 (21.8) with lugs 41 (18.6) without lugs
S811+T24N3S	7.65 (194.4)	12.71 (322.9)	6.47 (164.4)	48 (21.8) with lugs 41 (18.6) without lugs
S811+T30N3S	7.65 (194.4)	12.71 (322.9)	6.47 (164.4)	48 (21.8) with lugs 41 (18.6) without lugs
S811+U36N3S	7.73 (196.3)	12.72 (323.1)	7.16 (181.8)	48 (21.8) with lugs 41 (18.6) without lugs
S811+U42N3S	7.73 (196.3)	12.72 (323.1)	7.16 (181.8)	48 (21.8) with lugs 41 (18.6) without lugs
S811+U50N3S	7.73 (196.3)	12.72 (323.1)	7.16 (181.8)	48 (21.8) with lugs 41 (18.6) without lugs
S811+V36N3S	11.05 (280.6)	16.57 (420.8)	7.39 (187.8)	103 (46.8) with lugs 91 (41.4) without lugs
S811+V42N3S	11.05 (280.6)	16.57 (420.8)	7.39 (187.8)	103 (46.8) with lugs 91 (41.4) without lugs
S811+V50N3S	11.05 (280.6)	16.57 (420.8)	7.39 (187.8)	103 (46.8) with lugs 91 (41.4) without lugs
S811+V65N3S	11.05 (280.6)	16.57 (420.8)	7.39 (187.8)	103 (46.8) with lugs 91 (41.4) without lugs
S811+V72N3S	11.05 (280.6)	16.57 (420.8)	7.39 (187.8)	103 (46.8) with lugs 91 (41.4) without lugs
S811+V85N3S	11.05 (280.6)	16.57 (420.8)	7.39 (187.8)	103 (46.8) with lugs 91 (41.4) without lugs
S811+V10N3S	11.05 (280.6)	16.57 (420.8)	7.39 (187.8)	103 (46.8) with lugs 91 (41.4) without lugs

Also refer to dimension drawings on **Pages V6-T1-118** through **V6-T1-120**.**Note**

① Dimensions of the frames stay consistent between the N3S, P3S, and V3S options.

1.2

Reduced Voltage Motor Starters

Solid-State Starters

1

Approximate Dimensions in Inches (mm)

S811+N...

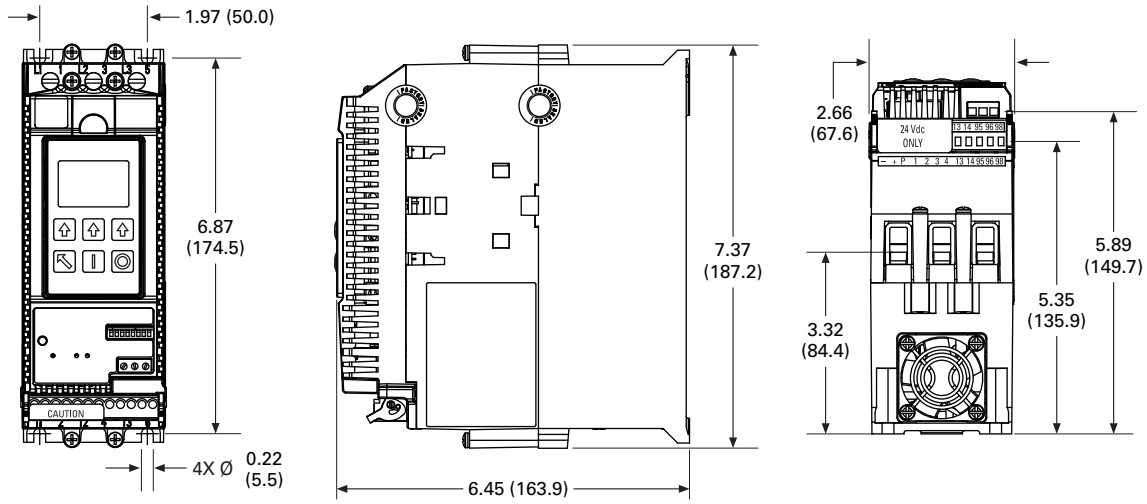

S811+R...

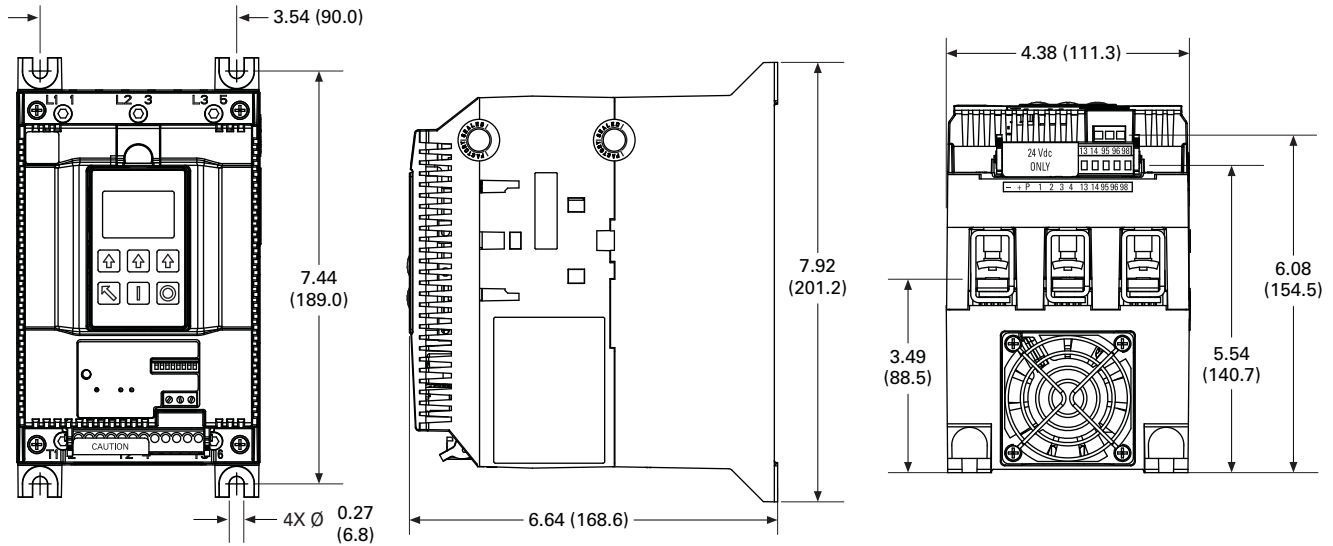

Approximate Dimensions in Inches (mm)

S811+T...

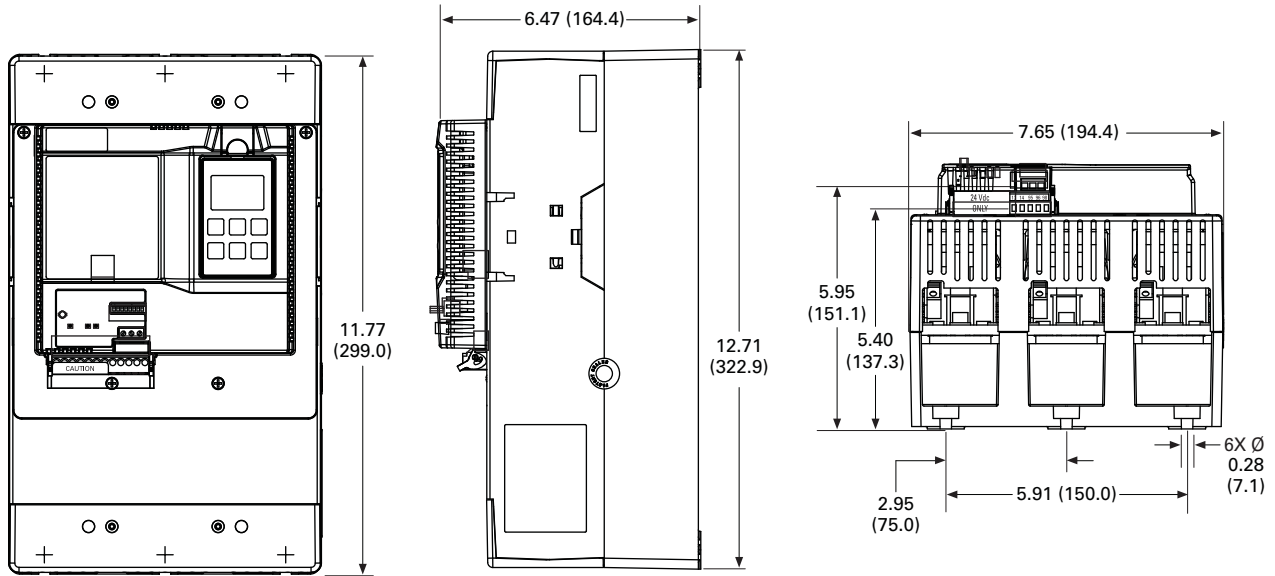

S811+U...

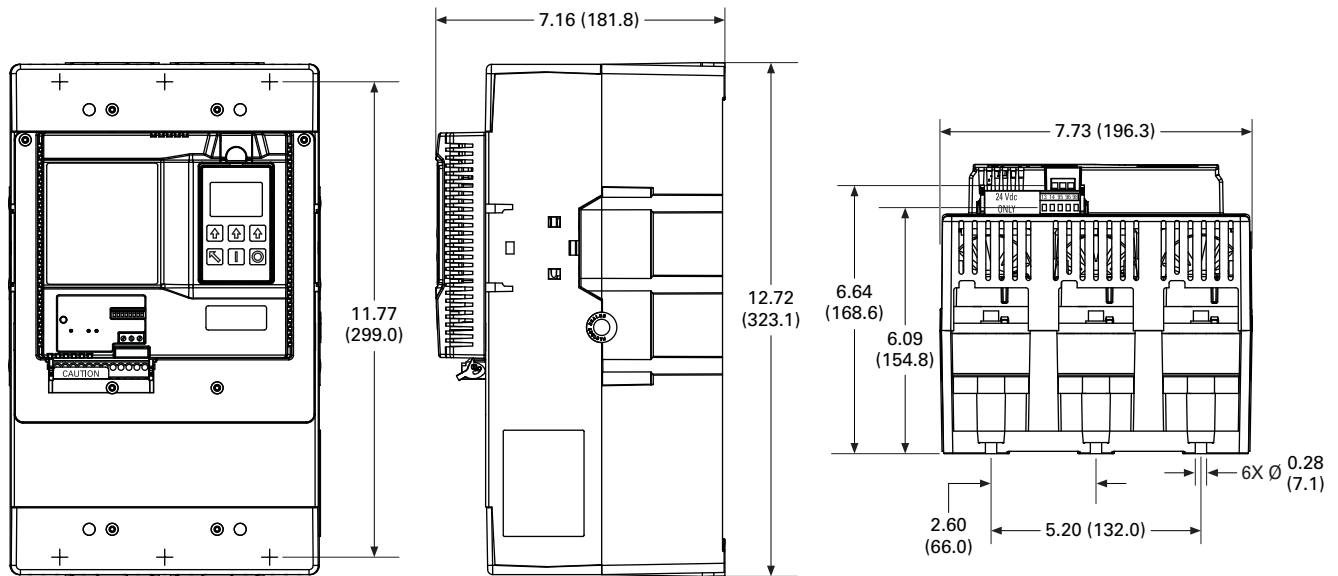

1.2

Reduced Voltage Motor Starters

Solid-State Starters

1

Approximate Dimensions in Inches (mm)

S811+V...

