

PowerXL™

DA1 Variable Frequency Drives I/O Configuration



Level 2	<p>1 – Fundamental – No previous experience necessary</p> <p>2 – Basic – Basic knowledge recommended</p> <p>3 – Advanced – Reasonable knowledge required</p> <p>4 – Expert – Good experience recommended</p>
---------	--

Content

1	General	5
2	Hardware	6
2.1	Designation of the control terminals and technical data	6
2.2	Connections	7
2.2.1	Terminal blocks for the control signals	7
2.2.2	Wiring example for the inputs	7
2.2.3	Relay outputs	7
2.2.4	STO (Safe Torque Off)	8
2.3	I/O extension with option modules	9
2.3.1	Integration of option modules into devices of the series DA1	9
2.3.2	Designation of the control terminals and technical data	10
2.3.3	LEDs	10
3	Configuration	11
3.1	Inputs	12
3.1.1	Digital inputs	12
3.1.2	Additional terminal functions in menu 9	16
3.1.3	Displaying input signals	17
3.1.4	Configuration of the analog inputs	18
3.2	Relay outputs	21
3.2.1	Selection of the functionality	21
3.2.2	User defined extension of the functionality selection	23
3.3	Static outputs	24
3.3.1	Selection of the functionality	24
3.3.2	User defined extension of the functionality selection	25
3.3.3	Configuration of the analog outputs	26

Danger! - Dangerous electrical voltage!

- Disconnect the power supply of the device.
- Ensure that devices cannot be accidentally restarted.
- Verify isolation from the supply.
- Cover or enclose any adjacent live components.
- Follow the engineering instructions (AWA/IL) for the device concerned.
- Only suitably qualified personnel in accordance with EN 50110-1/-2 (VDE 0105 Part 100) may work on this device/system.
- Before installation and before touching the device ensure that you are free of electrostatic charge.
- The functional earth (FE, PES) must be connected to the protective earth (PE) or the potential equalization. The system installer is responsible for implementing this connection.
- Connecting cables and signal lines should be installed so that inductive or capacitive interference does not impair the automatic control functions.
- Suitable safety hardware and software measures should be implemented for the I/O interface so that an open circuit on the signal side does not result in undefined states.
- Deviations of the mains voltage from the rated value must not exceed the tolerance limits given in the specification, otherwise this may cause malfunction and/or dangerous operation.
- Emergency stop devices complying with IEC/EN 60204-1 must be effective in all operating modes. Unlatching of the emergency-stop devices must not cause a restart.
- Devices that are designed for mounting in housings or control cabinets must only be operated and controlled after they have been properly installed and with the housing closed.
- Wherever faults may cause injury or material damage, external measures must be implemented to ensure a safe operating state in the event of a fault or malfunction (e.g. by means of separate limit switches, mechanical interlocks etc.).
- Frequency inverters may have hot surfaces during and immediately after operation.
- Removal of the required covers, improper installation or incorrect operation of motor or frequency inverter may destroy the device and may lead to serious injury or damage.
- The applicable national safety regulations and accident prevention recommendations must be applied to all work carried on live frequency inverters.
- The electrical installation must be carried out in accordance with the relevant electrical regulations (e. g. with regard to cable cross sections, fuses, PE).
- Transport, installation, commissioning and maintenance work must be carried out only by qualified personnel (IEC 60364, HD 384 and national occupational safety regulations).
- Installations containing frequency inverters must be provided with additional monitoring and protective devices in accordance with the applicable safety regulations. Modifications to the frequency inverters using the operating software are permitted.
- All covers and doors must be kept closed during operation.
- To reduce the hazards for people or equipment, the user must include in the machine design measures that restrict the consequences of a malfunction or failure of the frequency inverter (increased motor speed or sudden standstill of motor). These measures include:
 - Other independent devices for monitoring safety related variables (speed, travel, end positions etc.).
 - Electrical or non-electrical system-wide measures (electrical or mechanical interlocks).
 - Never touch live parts or cable connections of the frequency inverter after it has been disconnected from the power supply. Due to the charge in the capacitors, these parts may still be alive after disconnection. Consider appropriate warning signs.

Disclaimer

The information, recommendations, descriptions, and safety notations in this document are based on Eaton's experience and judgment and may not cover all contingencies. If further information is required, an Eaton sales office should be consulted. Sale of the product shown in this literature is subject to the terms and conditions outlined in the applicable Terms and Conditions for Sale of Eaton or other contractual agreement between Eaton and the purchaser. THERE ARE NO UNDERSTANDINGS, AGREEMENTS, WARRANTIES, EXPRESSED OR IMPLIED, INCLUDING WARRANTIES OF FITNESS FOR A PARTICULAR PURPOSE OR MERCHANTABILITY, OTHER THAN THOSE SPECIFICALLY SET OUT IN ANY EXISTING CONTRACT BETWEEN THE PARTIES. ANY SUCH CONTRACT STATES THE ENTIRE OBLIGATION OF EATON. THE CONTENTS OF THIS DOCUMENT SHALL NOT BECOME PART OF OR MODIFY ANY CONTRACT BETWEEN THE PARTIES. As far as applicable mandatory law allows so, in no event will Eaton be responsible to the purchaser or user in contract, in tort (including negligence), strict liability, or otherwise for any special, indirect, incidental, or consequential damage or loss whatsoever, including but not limited to damage or loss of use of equipment, plant or power system, cost of capital, loss of power, additional expenses in the use of existing power facilities, or claims against the purchaser or user by its customers resulting from the use of the information, recommendations, and descriptions contained herein. The information contained in this manual is subject to change without notice.

1 General

Devices of the series **PowerXL™ DA1** can be configured by parameterization to comply with the demands of the application. Not only internal variables like ramp times or speed are changed. It is also possible to modify the assignment of functions to control terminals. This possibility is universal inside the DA1 series and does not depend on the power rating.

This Application Note describes:

- the existing input and output terminals
- the possibility to extend the number of I/Os
- the technical data
- the assignment of functions to terminals
- the configuration of the I/Os

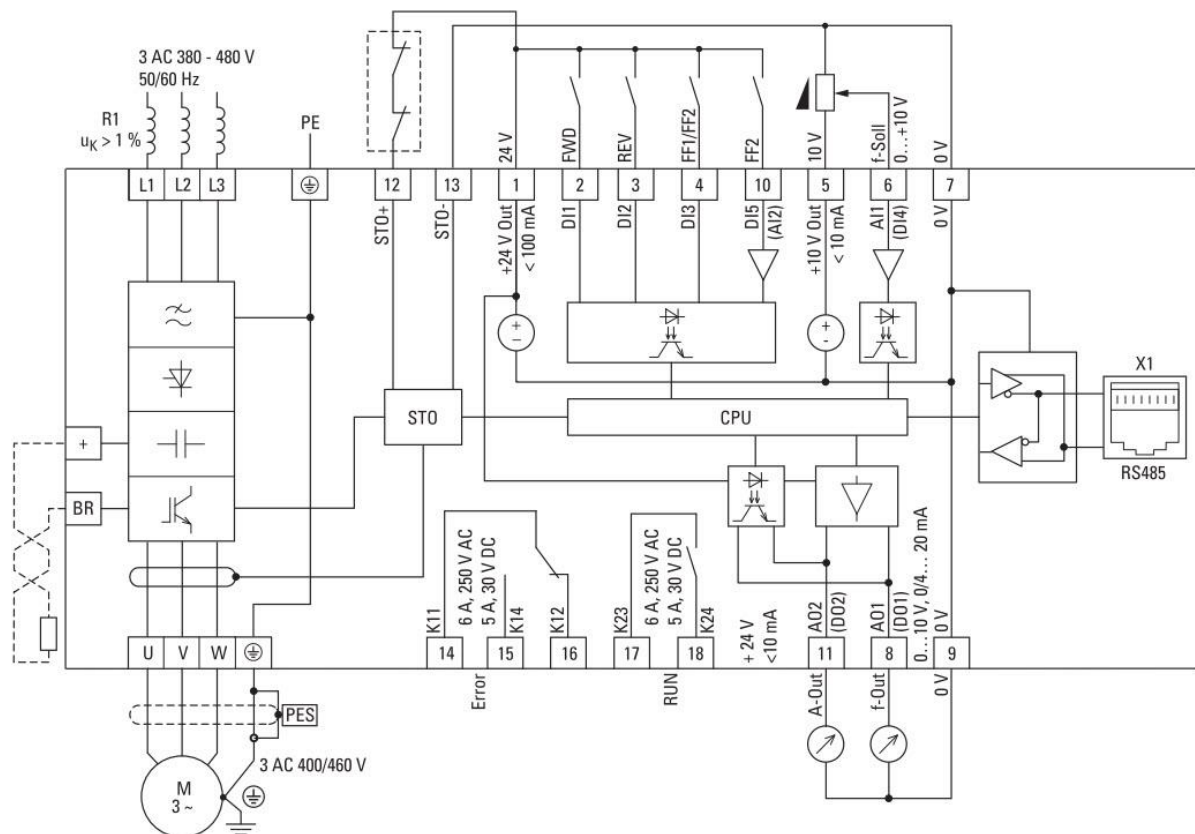

Wiring diagram of a variable frequency drive DA1 with default settings

2 Hardware

2.1 Designation of the control terminals and technical data

	Designation	Function	Default	
Basic unit DA1	1 (+24 V)	Control voltage for the digital inputs	100 mA max. Signal common: 0 V (terminals 7 and 9)	-
	2 (DI1)	Digital input 1	8 ... 30 V = High, $R_i > 6 \text{ k}\Omega$	FWD
	3 (DI2)	Digital input 2	8 ... 30 V = High, $R_i > 6 \text{ k}\Omega$	REV
	4 (DI3)	Digital input 3	8 ... 30 V = High, $R_i > 6 \text{ k}\Omega$	Select AI1REF / f-fix
	5 (+10 V)	Reference voltage	10 mA max. Signal common: 0 V (terminals 7 and 9)	-
	6 (AI1 / DI4)	Analog input 1 or digital input 4	analog: 0 ... 10 V, $R_i > 72 \text{ k}\Omega$ 0/4 ... 20 mA, $R_B = 500 \Omega$ digital: 8...30 V = High, $R_i > 72 \text{ k}\Omega$	AI1REF (analog, 0 ... 10 V)
	7 (0 V)	Signal common for all digital and analog inputs and outputs, together with terminal 9		-
	8 (AO1 / DO1)	Analog output 1 or digital output 1	analog: 0 ... 10 V, 20 mA max 0/4 ... 20 mA, 10 V max digital: 0 / 24 V, 20 mA max	Output frequency (analog, 0 ... 10 V)
	9 (0 V)	Signal common for all digital and analog inputs and outputs, together with terminal 7		-
	10 (AI2 / DI5)	Analog input 2 or digital input 5	analog: 0 ... 10 V, $R_i > 72 \text{ k}\Omega$ 0/4 ... 20 mA, $R_B = 500 \Omega$ digital: 8...30 V = High, $R_i > 72 \text{ k}\Omega$	Select f-Fix Bit0 (digital)
	11 (AO2/DO2)	Analog output 2 or digital output 2	analog: 0 ... 10 V, 20 mA max 0/4 ... 20 mA, 10 V max digital: 0 / 24 V, 20 mA max	Output current (analog, 0 ... 10 V)
	12 (STO+)	Safe Torque Off +	Enable = + 18 ... 30 V	STO+
	13 (STO-)	Safe Torque Off -	Signal common for STO+	STO-
	14 (K11)	Relay 1 common	250 V, 6 A AC / 30 V, 5 A DC	READY, ready for operation
	15 (K14)	Relay 1 NO		
	16 (K12)	Relay 1 NC		
	17 (K23)	Relay 2 NO	250 V, 6 A AC / 30 V, 5 A DC	RUN, device enabled
	18 (K24)			

All signals at the input and output terminals, except the relay contacts and STO, have the same signal common (terminals 7 and 9). The terminals 6, 8, 10 and 11 can be used as digital I/O as well as analog I/O. The respective function depends on the selection (see chapter 3ff).

2.2 Connections

2.2.1 Terminal blocks for the control signals

The terminal blocks for the control signals are pluggable

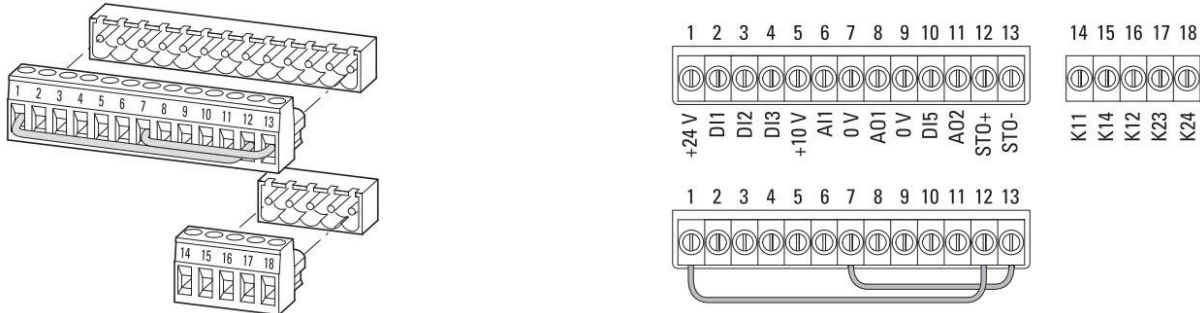

2.2.2 Wiring example for the inputs

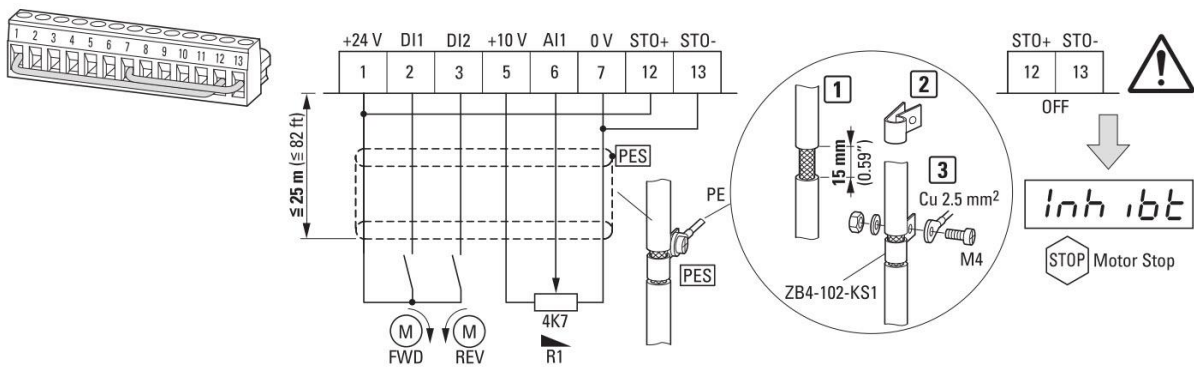

2.2.3 Relay outputs

Depending on the kind of load, we recommend the use of protection circuitry for the relay outputs.

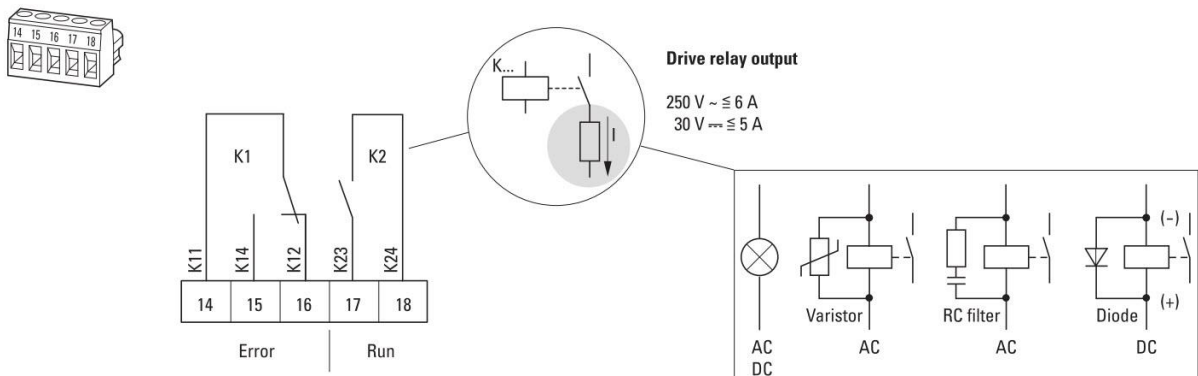

2.2.4 STO (Safe Torque Off)

A signal between the terminals 12 and 13 is always necessary to operate the variable frequency drive. Without this signal, the device cannot be operated and the display shows *l n h i b t* . In case the STO function is not used, the following terminals must be jumpered to operate the device:

- terminal 12 (STO+) with terminal 1 (+24 V)
- terminal 13 (STO-) with terminal 7 (0 V)

When the STO function is used, an external safety relay is necessary. The wiring has to be done with a shielded cable.

Connection examples:

- left: use of the internal control voltage
- right: external control voltage

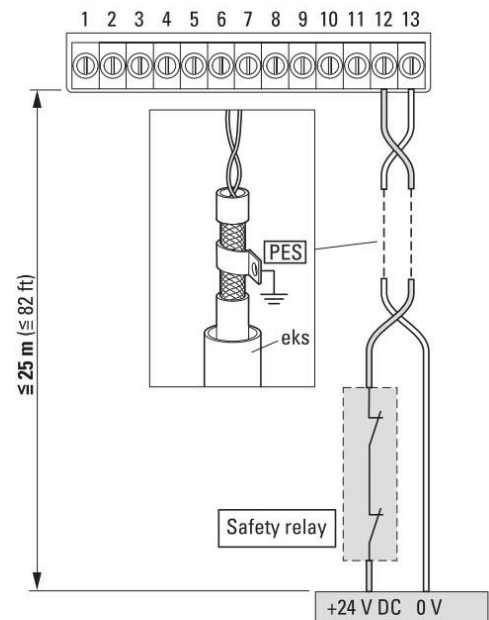
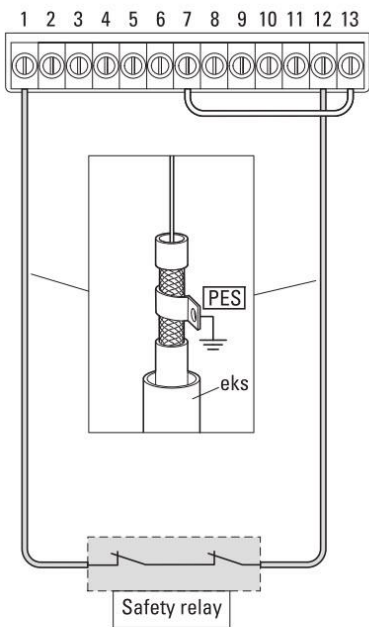

2.3 I/O extension with option modules

The variable frequency drives of the series DA1 have one slot to carry an option module. To extend the number of I/Os the modules DXA-EXT-3DI1RO or DXA-EXT-3RO can be used alternatively.

- DXA-EXT-3DI1RO 3 digital inputs, 1 relay output (NO)
- DXA-EXT-3RO 3 relay outputs (NO)

2.3.1 Integration of option modules into devices of the series DA1

The option modules are the same for all frame sizes. They are plugged into the respective slot and secured with two screws.

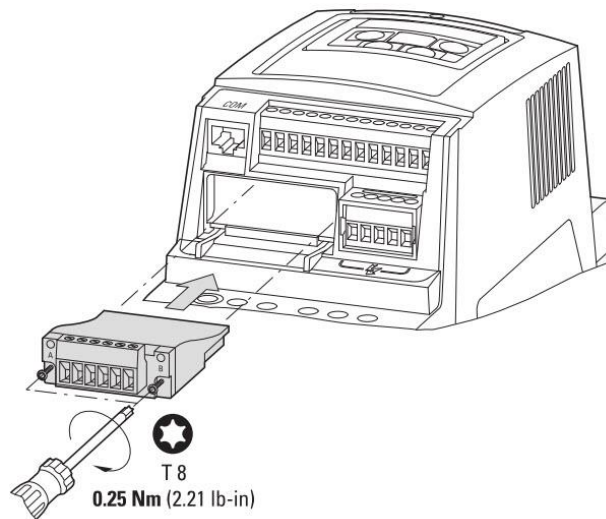

Mounting into devices of the frame sizes FS2 and FS3

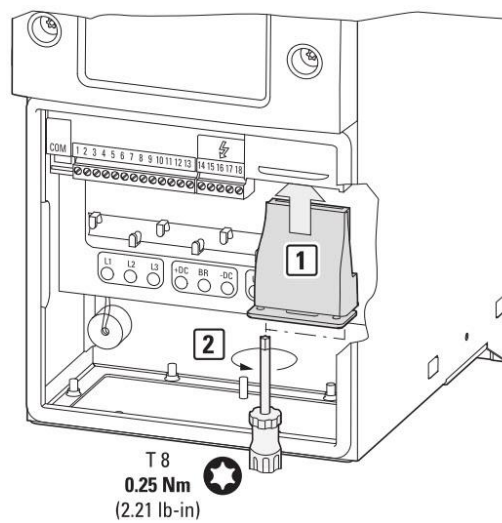

Mounting into devices of the frame sizes FS4 up to FS8

2.3.2 Designation of the control terminals and technical data

		Designation	Function	Default
DXA-EXT-3DI1RO	1 (DI6)	Digital input 6	8 ... 30 V = High, Ri > 6 kΩ	-
	2 (DI7)	Digital input 7	8 ... 30 V = High, Ri > 6 kΩ	
	3 (DI8)	Digital input 8	8 ... 30 V = High, Ri > 6 kΩ	
	4 (free)	not used		
	5 (K33) 6 (K34)	Relay 3 (NO)	250 V, 6 A AC / 30 V, 5 A DC	READY, DA1 ready for operation
DXA-EXT-3RO	1 (K33)	Relay 3 (NO)	250 V, 6 A AC / 30 V, 5 A DC	READY, DA1 ready for operation
	2 (K34)			
	3 (K43)	Relay 4 (NO)	250 V, 6 A AC / 30 V, 5 A DC	Fault
	4 (K44)			
	5 (K53) 6 (K54)	Relay 5 (NO)	250 V, 6 A AC / 30 V, 5 A DC	RUN, enabled (FWD/REV)

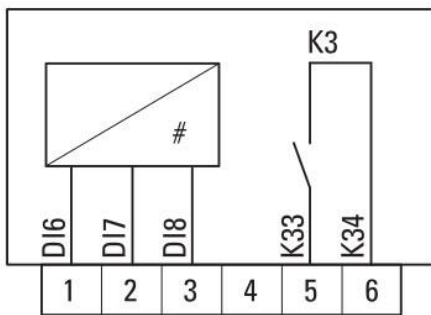

DXA-EXT-3DI1RO

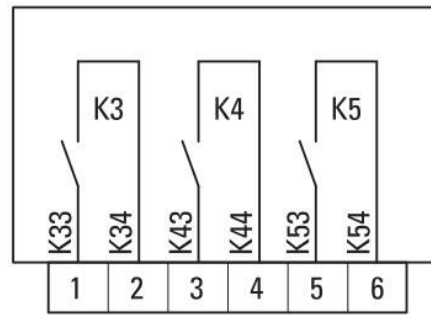

DXA-EXT-3RO

The signal common for the digital inputs DI6 ... DI8 of the option module DXA-EXT-3DI1RO is 0 V (terminals 7 and 9) of the basic device DA1.

Depending on the kind of load, we recommend the use of protection circuitry for the relay outputs (see 2.2.3).

By default, no function is assigned to the inputs DI6 ... DI8. This is done by the user in menu 9. Please note: P1-13 = 0 has to be selected to set up a user specific configuration.

2.3.3 LEDs

LED „A“ lights green	module OK
LED „A“ flashes green	no communication with the basic unit
LED „A“ OFF	Supply voltage missing
LED „B“	not used

3 Configuration

The table gives an overview, how to determine the function of the single I/Os and which kind of configuration possibilities exist. More details see below.

	Designation	Selection / setting of				
		Function	Format (signal range)	Scaling (gain)	Offset	Hysteresis
Basic device DA1	1 (+24 V)	fixed	-	-	-	-
	2 (DI1)	P1-12 / P1-13	-	-	-	-
	3 (DI2)		-	-	-	-
	4 (DI3)		-	-	-	-
	5 (+10 V)		fixed	-	-	-
	6 (AI1 / DI4)	P1-12 / P1-13	P2-30	P2-31	P2-32	-
	7 (0 V)	fixed	-	-	-	-
	8 (AO1 / DO1)	P2-11 / P9-33	P2-12	P6-26	P6-27	P2-16 / P2-17 / P6-04
	9 (0 V)	fixed	-	-	-	-
	10 (AI2 / DI5)	P1-12 / P1-13	P2-33	P2-34	P2-35	-
	11 (AO2/DO2)	P2-13 / P9-34	P2-14	-	-	P2-19 / P2-20 / P6-04
	12 (STO+)	fixed	-	-	-	-
	13 (STO-)		-	-	-	-
	14 (K11)	P2-15 / P9-35	-	-	-	P2-16 / P2-17 / P6-04
	15 (K14)		-	-	-	-
	16 (K12)		-	-	-	-
	17 (K23)	P2-18 / P9-36	-	-	-	P2-19 / P2-20 / P6-04
	18 (K24)		-	-	-	-
DXA-EXT-3DI1RO	1 (DI6)	Menu 9	-	-	-	-
	2 (DI7)		-	-	-	-
	3 (DI8)		-	-	-	-
	4 (frei)	-				
	5 (K33)	Menu 9 / P9-41	-	-	-	-
	6 (K34)		-	-	-	-
DXA-EXT-3RO	1 (K33)	Menu 9 / P9-41	-	-	-	-
	2 (K34)		-	-	-	-
	3 (K43)	Menu 9 / P9-41	-	-	-	-
	4 (K44)		-	-	-	-
	5 (K53)	Menu 9 / P9-41	-	-	-	-
	6 (K54)		-	-	-	-

Hint:

The terminal function of the basic device DA1 can be selected out of predefined combinations with parameters P1-12 and P1-13. Furthermore a user definition in menu 9 is possible. In this case → P1-13 = 0.

3.1 Inputs

The determination of the input functions is done with parameter “DI Config Select” (P1-13). There are 20 predefined combinations, which cover the majority of applications. Furthermore the user can define his specific setting in menu 9. In this case → P1-13 = 0.

The available terminal combinations in parameter P1-13 depend on the selection of the “Local ProcessData Source” (P1-12). The information given below refer to terminal mode (P1-12 = 0) only. The possible terminal combinations for settings different from P1-12 = 0 can be found in chapter 3 “Control terminals” of the parameter manual MN040Z0006ZEN.

3.1.1 Digital inputs

PNU	Parameter	Name	Range	Default
423.0	P1-13	DI Config Select	0 ... 21	11

P1-12 = 0: Terminal control					
P1-13	DI1 (Terminal 2)	DI2 (Terminal 3)	DI3 (Terminal 4)	DI4/AI1 (Terminal 6)	DI5/AI2 (Terminal 10)
0	user defined	user defined	user defined	user defined	user defined
1	START	DIR	Select AI1 REF / f-Fix	AI1 REF	Select f-Fix Bit0
2	START	DIR	Select f-Fix Bit0	Select f-Fix Bit1	Select f-Fix Bit2
3	START	DIR	Select AI1 REF / f-Fix1	AI1 REF	AI2 Torque REF
4	START	DIR	Select AI1 REF / f-Fix1	AI1 REF	Select t-dec1 / t-dec2
5	START	DIR	Select AI1 REF / AI2 REF	AI1 REF	AI2 REF
6	START	DIR	Select AI1 REF / f-Fix1	AI1 REF	EXTFLT
7	START	DIR	Select f-Fix Bit0	Select f-Fix Bit1	EXTFLT
8	START	DIR	Select f-Fix Bit0	Select f-Fix Bit1	Select t-dec1 / t-dec2
9	START	DIR	Select f-Fix Bit0	Select f-Fix Bit1	Select AI1 REF / f-Fix
10	START	DIR	UP	DOWN	Select DIG REF / f-Fix1
11	FWD	REV	Select AI1 REF / f-Fix	AI1 REF	Select f-Fix Bit0
12	FWD	REV	Select f-Fix Bit0	Select f-Fix Bit1	Select f-Fix Bit2
13	FWD	REV	Select AI1 REF / f-Fix1	AI1 REF	AI2 Torque REF
14	FWD	REV	Select AI1 REF / f-Fix1	AI1 REF	Select t-dec1 / t-dec2
15	FWD	REV	Select AI1 REF / AI2 REF	AI1 REF	AI2 REF
16	FWD	REV	Select AI1 REF / f-Fix1	AI1 REF	EXTFLT
17	FWD	REV	Select f-Fix Bit0	Select f-Fix Bit1	EXTFLT
18	FWD	REV	Select f-Fix Bit0	Select f-Fix Bit1	Select t-dec1 / t-dec2
19	FWD	REV	Select f-Fix Bit0	Select f-Fix Bit1	Select AI1 REF / f-Fix
20	FWD	REV	UP	DOWN	Select REF / f-Fix1
21	Pulse FWD (NO)	Pulse STOP (NC)	Pulse REV (NO)	AI1 REF	Select AI1 REF / f-Fix1

For the terminal functions the abbreviations below are used (Values in brackets: parameter numbers for manual configuration by the user):

Abbreviation	Function
AI1 REF (P9-10 ... P9-17)	Analog input AI1 (terminal 6) is used as speed reference input. P2-30: Format (voltage input / current input ...) P2-31: Scaling P2-32: Offset
AI2 REF (P9-10 ... P9-17)	Analog input AI2 (terminal 10) is used as speed reference input. P2-33: Format (voltage input / current input ...) P2-34: Scaling P2-35: Offset
AI2 Torque REF (P9-40)	Analog input AI2 (terminal 10) is used as torque reference input. P2-33: Format (voltage input / current input ...) P2-34: Scaling P2-35: Offset

Abbreviation	Function
DIR (P9-06)	Used for the selection of the sense of rotation in connection with the START command. Low = cw (FWD) High = ccw (REV) ATTENTION: in case of a wire break the drive reverses in case REV is selected! Alternative: use configuration with FWD/REV.
DOWN (P9-29)	“Reduce speed” command, when a digital reference is selected (P1-12 = 1 or 2). Used in combination with the command UP.
ENA (P9-01)	Enable variable frequency drive. To start the drive an additional start signal (START, FWD, REV) is necessary. When removing ENA, the motor coasts to stop.
EXTFLT (P9-08)	External fault. Enables the inclusion of an external signal into the fault messages of the variable frequency drive. During operation a High signal must be applied to the terminal. A Low signal leads to a trip with the message “E-Err iP”.
FWD (P9-03)	START with a clockwise rotating field (FWD = Forward). When applying a High signal to the respective terminal, the drive accelerates with the predefined ramp. Removing the signal leads to a stop. The stop behavior depends on the setting of P1-05 “Stop Mode”. At standstill the variable frequency drive is disabled. In applications with two directions, counter clockwise rotation is selected with REV. FWD and REV are logically connected (XOR). Applying both signals at the same time leads to a Quick Stop with the ramp defined with P2-25.
INV (P9-04)	Inversion of the sense of rotation. During the change of direction the predefined ramps are active. Low = no inversion, High = Inversion
Pulse FWD (NO) Pulse REV (NO) Pulse STOP (NC) (P9-01, P9-03, P9-04, P9-05, P9-07)	Pulse control. The control of the drive is done with pulses, similar to a control of reversing contactors. To run the drive, the signal “PULSE STOP” must always be applied to the terminal. In case of a Low signal, the drive cannot be started, respectively the drive ramps to standstill. To start, only a pulse of the signal “PULSE FWD” or “PULSE REV” is necessary. The signal doesn’t need to be applied constantly during operation. To stop the drive, a short interruption of the signal “PULSE STOP” is sufficient. To use this function → P9-05 = 1
REV (P9-04)	START with a counter clockwise rotating field (REV = Reverse). When applying a High signal to the respective terminal, the drive accelerates with the predefined ramp. Removing the signal leads to a stop. The stop behavior depends on the setting of P1-05 “Stop Mode”. At standstill the variable frequency drive is disabled. In applications with two directions, clockwise rotation is selected with FWD. FWD and REV are logically connected (XOR). Applying both signals at the same time leads to a Quick Stop with the ramp defined with P2-25.
Select AI1 REF / AI2 REF (P9-18, P9-21, P9-22)	Selection between the analog references AI1 (at terminal 6) and AI2 (at terminal 10). Low = AI1, High = AI2
Select AI1 REF / f-Fix (P9-18)	Selection between the analog speed reference at analog input AI1 (terminal 6) and a fixed frequency. The fixed frequency itself is selected with the commands “Select f-Fix Bit0 ... 2”. Low = analog reference, High = Fixed frequency

Abbreviation	Function																																				
Select AI1 REF / f-Fix1 (P9-18, P9-21, P9-22)	Selection between the analog speed reference at analog input AI1 (terminal 6) and the fixed frequency 1 (f-Fix1), set with P2-01. Low = analog reference, High = f-Fix1																																				
Select BUS REF / AI2 REF (P9-18, P9-21, P9-22)	Selection between references. Low = reference from a field bus or a master drive (P1-12 = 5), High = AI2																																				
Select BUS REF / f-Fix (P9-18, P9-19, P9-20, P9-21, P9-22)	Selection between references. Low = reference from a field bus or a master drive (P1-12 = 5), High = Fixed frequency The fixed frequency itself is selected with the commands "Select f-Fix Bit0 ... 2".																																				
Select BUS REF / f-Fix1 (P9-18, P9-21, P9-22)	Selection between references. Low = reference from a field bus or a master drive (P1-12 = 5), High = f-Fix1, set with P2-01																																				
Select DIG REF / AI2 REF (P9-18, P9-21, P9-22)	Selection between a digital reference, set with a keypad or via the commands UP and DOWN and the analog reference AI2 REF (terminal 10) Low: digital reference, High: AI2 REF																																				
Select DIG REF / f-Fix (P9-18, P9-19, P9-20, P9-21, P9-22)	Selection between a digital reference, set with a keypad or via the commands UP and DOWN and a fixed frequency. The fixed frequency itself is selected with the commands "Select f-Fix Bit0 ... 2". Low = digital reference, High = fixed frequency																																				
Select DIG REF / f-Fix1 (P9-18, P9-21, P9-22)	Selection between a digital reference, set with a keypad or via the commands UP and DOWN and f-Fix1, set with P2-01 Low = digital reference, High = f-Fix1																																				
Select f-Fix Bit 0 Select f-Fix Bit 1 Select f-Fix Bit 2 (P9-21, P9-22, P9-23)	Selection of the fixed frequency with digital commands. The fixed frequencies f-Fix1 ... f-Fix8 are defined with P2-01 ... P2-08. <table border="1" data-bbox="544 1211 1391 1547"> <thead> <tr> <th></th> <th>Bit 2</th> <th>Bit 1</th> <th>Bit 0</th> </tr> </thead> <tbody> <tr> <td>f-Fix 1 (P2-01)</td> <td>Low</td> <td>Low</td> <td>Low</td> </tr> <tr> <td>f-Fix 2 (P2-02)</td> <td>Low</td> <td>Low</td> <td>High</td> </tr> <tr> <td>f-Fix 3 (P2-03)</td> <td>Low</td> <td>High</td> <td>Low</td> </tr> <tr> <td>f-Fix 4 (P2-04)</td> <td>Low</td> <td>High</td> <td>High</td> </tr> <tr> <td>f-Fix 5 (P2-05)</td> <td>High</td> <td>Low</td> <td>Low</td> </tr> <tr> <td>f-Fix 6 (P2-06)</td> <td>High</td> <td>Low</td> <td>High</td> </tr> <tr> <td>f-Fix 7 (P2-07)</td> <td>High</td> <td>High</td> <td>Low</td> </tr> <tr> <td>f-Fix 8 (P2-08)</td> <td>High</td> <td>High</td> <td>High</td> </tr> </tbody> </table>		Bit 2	Bit 1	Bit 0	f-Fix 1 (P2-01)	Low	Low	Low	f-Fix 2 (P2-02)	Low	Low	High	f-Fix 3 (P2-03)	Low	High	Low	f-Fix 4 (P2-04)	Low	High	High	f-Fix 5 (P2-05)	High	Low	Low	f-Fix 6 (P2-06)	High	Low	High	f-Fix 7 (P2-07)	High	High	Low	f-Fix 8 (P2-08)	High	High	High
	Bit 2	Bit 1	Bit 0																																		
f-Fix 1 (P2-01)	Low	Low	Low																																		
f-Fix 2 (P2-02)	Low	Low	High																																		
f-Fix 3 (P2-03)	Low	High	Low																																		
f-Fix 4 (P2-04)	Low	High	High																																		
f-Fix 5 (P2-05)	High	Low	Low																																		
f-Fix 6 (P2-06)	High	Low	High																																		
f-Fix 7 (P2-07)	High	High	Low																																		
f-Fix 8 (P2-08)	High	High	High																																		
Select PID REF / AI2 REF (P9-18, P9-21, P9-22)	Selection between references. Low = reference from the output of the PID controller, High = AI2																																				
Select PID REF / f-Fix (P9-18, P9-19, P9-20, P9-21, P9-22)	Selection between references. Low = reference from the output of the PID controller, High = AI2 The fixed frequency itself is selected with the commands "Select f-Fix Bit0 ... 2".																																				
Select PID REF / f-Fix1 (P9-18, P9-21, P9-22)	Selection between references. Low = reference from the output of the PID controller, High = f-Fix1, set with P2-01																																				
Select Quick-Dec (P9-02)	In case a High signal is applied to both inputs at the same time, a Quick Stop is performed , using the ramp set with P2-25.																																				

Abbreviation	Function
Select t-dec1 / t-dec2 (P9-26)	Selection between deceleration ramp 1 „t-dec“, set with P1-04 and t-dec2“ (P8-11) Low = „t-dec“, High = t-dec2
START (P9-03, P9-04)	Starts the drive. When applying a High signal to the respective terminal, the drive accelerates with the predefined ramp. Removing the signal leads to a stop. The stop behavior depends on the setting of P1-05 “Stop Mode”. At standstill the variable frequency drive is disabled. In applications with two directions the commands DIR respectively REV are used.
UP (P9-28)	“Increase speed” command, when a digital reference is selected (P1-12 = 1 or 2). Used in combination with the command DOWN.

3.1.2 Additional terminal functions in menu 9

Beside a selection of predefined sets of terminal configurations there is a possibility to create an individual one inside menu 9. This offers more flexibility as well as additional functions. Depending on the required number of inputs and outputs, they have to be extended by using option modules (see chapter 2.3.x).

Additional terminal functions with an individual configuration (P1-13 = 0, definition inside menu 9):

Abbreviation	Function																																				
ENA FWD (P9-30)	Enable clockwise rotating field (FWD) Logic 0 = An operation with clockwise rotating field is not possible. If the motor turns already, when the signal changes from logic 1 to logic 0, the drive stops with the quick stop ramp set with P2-25. Logic 1: An operation with clockwise rotating field is possible.																																				
ENA REV (P9-31)	Enable counter clockwise rotating field (REV) Logic 0 = An operation with counter clockwise rotating field is not possible. If the motor turns already, when the signal changes from logic 1 to logic 0, the drive stops with the quick stop ramp set with P2-25. Logic 1: An operation with counter clockwise rotating field is possible.																																				
Force REV (P9-06)	Force operation with counter clockwise rotating field This signal (logic = 1) forces the drive to run with counter clockwise rotating field. It is irrelevant, if the FWD or the REV command is applied. Without this signal (logic = 0) the sense of rotation is determined by FWD and REV commands.																																				
Local/Remote (P9-09)	This parameter is only effective with P1-12 > 0. It enables the change-over between the command channel defined by P1-12 and the sources selected with P9-01 ... P9-07 Logic 0 = Command channel according P1-12 Logic 1 = The drive is controlled by the sources defined with P9-01 ... P9-07																																				
RESET (P9-07)	A rising edge of this signal (from logic 0 to 1) resets existing fault messages.																																				
Select Speed Bit 0 Select Speed Bit 1 Select Speed Bit 2 (P9-18, P9-19, P9-20)	The signals at the terminals (defined by P9-18 ... P9-20) determine the selection of the actual speed reference value, defined by P9-10 ... P9-17. <table border="1" data-bbox="544 1704 1386 2038"> <thead> <tr> <th></th> <th>Bit 2</th> <th>Bit 1</th> <th>Bit 0</th> </tr> </thead> <tbody> <tr> <td>Speed 1 (P9-10)</td> <td>Low</td> <td>Low</td> <td>Low</td> </tr> <tr> <td>Speed 2 (P9-11)</td> <td>Low</td> <td>Low</td> <td>High</td> </tr> <tr> <td>Speed 3 (P9-12)</td> <td>Low</td> <td>High</td> <td>Low</td> </tr> <tr> <td>Speed 4 (P9-13)</td> <td>Low</td> <td>High</td> <td>High</td> </tr> <tr> <td>Speed 5 (P9-14)</td> <td>High</td> <td>Low</td> <td>Low</td> </tr> <tr> <td>Speed 6 (P9-15)</td> <td>High</td> <td>Low</td> <td>High</td> </tr> <tr> <td>Speed 7 (P9-16)</td> <td>High</td> <td>High</td> <td>Low</td> </tr> <tr> <td>Speed 8 (P9-17)</td> <td>High</td> <td>High</td> <td>High</td> </tr> </tbody> </table>		Bit 2	Bit 1	Bit 0	Speed 1 (P9-10)	Low	Low	Low	Speed 2 (P9-11)	Low	Low	High	Speed 3 (P9-12)	Low	High	Low	Speed 4 (P9-13)	Low	High	High	Speed 5 (P9-14)	High	Low	Low	Speed 6 (P9-15)	High	Low	High	Speed 7 (P9-16)	High	High	Low	Speed 8 (P9-17)	High	High	High
	Bit 2	Bit 1	Bit 0																																		
Speed 1 (P9-10)	Low	Low	Low																																		
Speed 2 (P9-11)	Low	Low	High																																		
Speed 3 (P9-12)	Low	High	Low																																		
Speed 4 (P9-13)	Low	High	High																																		
Speed 5 (P9-14)	High	Low	Low																																		
Speed 6 (P9-15)	High	Low	High																																		
Speed 7 (P9-16)	High	High	Low																																		
Speed 8 (P9-17)	High	High	High																																		

Abbreviation	Function															
Select t-acc Bit 0 Select t-acc Bit 1 (P9-24, P9-25)	Selection of alternative acceleration ramps. Condition → P8-13 = 0. Otherwise the selection of the ramps is speed dependent. See also AP0040031EN „Use of multiple ramps“. <table border="1" data-bbox="545 405 1201 591"> <thead> <tr> <th></th> <th>Bit 1</th> <th>Bit 0</th> </tr> </thead> <tbody> <tr> <td>t-acc (P1-03)</td> <td>Low</td> <td>Low</td> </tr> <tr> <td>t-acc 2 (P8-01)</td> <td>Low</td> <td>High</td> </tr> <tr> <td>t-acc 3 (P8-03)</td> <td>High</td> <td>Low</td> </tr> <tr> <td>t-acc 4 (P8-05)</td> <td>High</td> <td>High</td> </tr> </tbody> </table>		Bit 1	Bit 0	t-acc (P1-03)	Low	Low	t-acc 2 (P8-01)	Low	High	t-acc 3 (P8-03)	High	Low	t-acc 4 (P8-05)	High	High
	Bit 1	Bit 0														
t-acc (P1-03)	Low	Low														
t-acc 2 (P8-01)	Low	High														
t-acc 3 (P8-03)	High	Low														
t-acc 4 (P8-05)	High	High														
Select t-dec Bit 0 Select t-dec Bit 1 (P9-26, P9-27)	Selection of alternative deceleration ramps. Condition → P8-13 = 0. Otherwise the selection of the ramps is speed dependent. See also AP0040031EN „Use of multiple ramps“. <table border="1" data-bbox="545 734 1201 920"> <thead> <tr> <th></th> <th>Bit 1</th> <th>Bit 0</th> </tr> </thead> <tbody> <tr> <td>t-dec (P1-04)</td> <td>Low</td> <td>Low</td> </tr> <tr> <td>t-dec 2 (P8-11)</td> <td>Low</td> <td>High</td> </tr> <tr> <td>t-dec 3 (P8-09)</td> <td>High</td> <td>Low</td> </tr> <tr> <td>t-dec 4 (P8-07)</td> <td>High</td> <td>High</td> </tr> </tbody> </table>		Bit 1	Bit 0	t-dec (P1-04)	Low	Low	t-dec 2 (P8-11)	Low	High	t-dec 3 (P8-09)	High	Low	t-dec 4 (P8-07)	High	High
	Bit 1	Bit 0														
t-dec (P1-04)	Low	Low														
t-dec 2 (P8-11)	Low	High														
t-dec 3 (P8-09)	High	Low														
t-dec 4 (P8-07)	High	High														

3.1.3 Displaying input signals

The status of the inputs can be displayed by selecting the respective parameters.

PNU	Parameter	Name	Range	Default
560.0	P0-01	Analog Input1	0.0 ... 100 % input signal	-
560.1	P0-02	Analog Input2	0.0 ... 100 % input signal	-
550.0 ... 550.7	P0-03	DI1 Status	0 / 1	-

The values, displayed with P0-01 and P0-02, take also potential scaling factors and offset into account. Example for AI1: $P0-01 = (\text{Signal at AI1 [\%]} - P2-32) \cdot P2-31$

The display on the keypad can be used to see the status of the digital inputs located on the basic unit DA1 (DI1 ... DI5) with P0-03. It starts with DI1 on the left hand side of the display. \square = Low signal, $|$ = High signal at the respective input terminal.

When using the parameter software DrivesConnect also the status of the inputs DI6 ... DI8 located on the option module DXA-EXT-3DI1RO is displayed.

Voltages between 8 and 30 V are identified as High signal. If an input is configured as analog input, its status is displayed in P0-03 with \square with voltage levels up to 8 V, above this with $|$.

When the terminals 6 and/or 10 are configured as digital input, the Parameters P0-01 respectively P0-02 show $\square\square$ when a Low signal is applied and $| \square \square$ when a High signal is applied.

3.1.4 Configuration of the analog inputs

Depending on which terminal configuration is selected with P1-13, up to two analog inputs are available. Both inputs can be adapted to the format (voltage or current) of the analog input signal.

It is also possible to take a scaling factor and an offset into account.

- Signal range: Selection of the kind of signal at the analog inputs. The maximum value of the signal corresponds to the maximum speed / frequency set with P0-01.
- Gain: With the gain the analog inputs can be scaled. It applies to the value at terminal 6 (AI1) respectively terminal 10 (AI2) as well as to possible offsets.
- Offset: Offset of the analog input. 100 % corresponds to the maximum speed / frequency set with P1-01.

ATTENTION: the offset is subtracted from the value at terminal 6 respectively terminal 10. Means: positive values result in a reduction, negative ones in an increase.

3.1.4.1 Analog input 1

PNU	Parameter	Name	Range	Default
260.0	P2-30	AI1 Signal Range	0: 0 ... 10 V (<i>U 0-10</i>) 1: 10 ... 0 V (<i>U 10-0</i>) 2 : bipolar 0 ... 10 V (<i>- 10- 10</i>) 3: 0 ... 20 mA (<i>I 0-20</i>) 4: t 4 ... 20 mA (trip in case of wire break) (<i>t 4-20</i>) 5: r 4 ... 20 mA (ramps to f-Fix8 (P2-08) in case of wire break) (<i>r 4-20</i>) 6: t 20 ... 4 mA (trip in case of wire break) (<i>t 20-4</i>) 7: r 20 ... 4 mA (ramps to f-Fix8 (P2-08) in case of wire break) (<i>r 20-4</i>)	0
261.0	P2-31	AI1 Gain	0.0 ... 500.0 %	100.0 %
262.0	P2-32	AI1 Offset	-500.0 % ... + 500.0 %	0.0 %

3.1.4.2 Analog input 2

PNU	Parameter	Name	Range	Default
260.1	P2-33	AI2 Signal Bereich	0: 0 ... 10 V (<i>U 0-10</i>) 1: 10 ... 0 V (<i>U 10-0</i>) 2: Thermistor (<i>Ptc-th</i>) 3: 0 ... 20 mA (<i>A 0-20</i>) 4: t 4 ... 20 mA (trip in case of wire break) (<i>t 4-20</i>) 5: r 4 ... 20 mA (ramps to f-Fix8 (P2-08) in case of wire break) (<i>r 4-20</i>) 6: t 20 ... 4 mA (trip in case of wire break) (<i>t 20-4</i>) 7: r 20 ... 4 mA (ramps to f-Fix8 (P2-08) in case of wire break) (<i>r 20-4</i>)	0
261.1	P2-34	AI2 Gain	0.0 ... 500.0 %	100.0 %
262.1	P2-35	AI2 Offset	-500.0 % ... + 500.0 %	0.0 %

Analog input AI2 can be configured in a way, that a thermistor for motor protection can be connected.

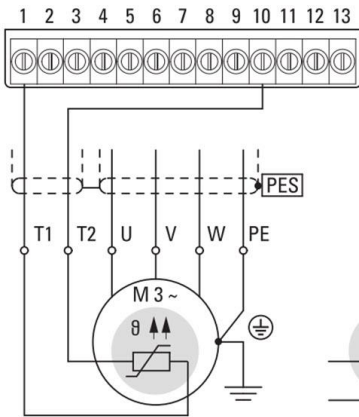

Parameter P1-13 has to be set in a way, that the function „External Fault“ (EXTFLT) is assigned to terminal 10 (DI5 / AI2). During proper operation, a High signal is applied to terminal 10. In case of fault the temperature contact must open respectively the resistance of the thermistor has to increase. DA1 trips at a resistance of $\geq 2.5 \text{ k}\Omega$, Reset can be performed at values $\leq 1.9 \text{ k}\Omega$.

ATTENTION: Variable frequency drives of the series DA1 are designed according IEC / EN 61800-5-1, which requires double isolation between mains circuits and circuits with low voltage. Inside the drive power part and control part are separated accordingly. In case temperature sensors inside the motor are connected to DA1, the sensors have to be double isolated against the motor windings, not to weaken the overall insulation system!

3.1.4.3 Example for the configuration of an analog input

A speed reference, coming from an external device (4 ... 20 mA), is applied to analog input 1 (terminal 6) of a variable frequency drive DA1. With references below 8 mA the drive shall stand still and it shall reach its max. speed with a signal of 15 mA. In case of a wire break inside the reference circuit, the drive shall trip.

Trip in case of wire break:

„AI1 Signal Range“ (P2-30) = 4 (trip in case of wire break) (~~4-20~~)

Scaling factor „AI1 Gain“ (P2-31):

Under normal operating conditions (4 mA = standstill, 20 mA = 100 % speed) the current range corresponds to 16 mA (20 mA – 4 mA). In this example the range is 7 mA only (15 mA – 8 mA).

$$P2-31 = \frac{20 \text{ mA} - 4 \text{ mA}}{15 \text{ mA} - 8 \text{ mA}} \cdot 100 \% = \frac{16 \text{ mA}}{7 \text{ mA}} \cdot 100 \% = 228.6 \%$$

„AI1 Offset“ (P2-32)

The motor shall start to turn at 8 mA of the reference signal. 8 mA normally correspond to 25 % speed reference when using a signal of 4 ... 20 mA. Therefore the offset must be set to 25 %. The sign of the offset is positive, because the offset is subtracted from the input signal.

$$\text{Speed reference, displayed with P0-01} = (\text{Signal at AI1 [\%]} - P2-32) \cdot P2-31$$

The value doesn't drop below zero and is limited in the upper range by P1-01 „f-max“.

3.2 Relay outputs

3.2.1 Selection of the functionality

The functionality of the relays, located on the basic device, can be selected with parameters P2-15 and P2-18. When using the option DXA-EXT-3DI1RO or DXA-EXT-3RO the functionality of the relays is defined by default.

With the settings P2-15 / P2-18 = 2 or 3 the relay indicates, if the motor is at standstill respectively if the motor speed corresponds to the reference value. To prevent a “chatter” of the relay in case of small deviations, one can define a band around the actual speed value with “RO1 n-Hysteresis” (P6-04). If the speed signal is inside the band, it is defined as “speed = zero” respectively “speed = speed reference”.

For the settings P2-15 / P2-18 = 4 ... 7 thresholds for upper and lower limits (Hysteresis) can be defined with parameters P2-16 / P2-17 for RO1 and P2-19 / P2-20 for RO2.

PNU	Parameter	Name	Range	Default
451.0	P2-15	RO1 Function	0: RUN, enable (FWD/REV) 1: READY, DA1 ready for operation 2: Speed = speed reference value 3: Speed > Speed Zero 4: Speed; ON: \geq P2-16 / OFF: < P2-17 5: Motor current; ON: \geq P2-16 / OFF: < P2-17 6: Motor torque; ON: \geq P2-16 / OFF: < P2-17 7: Analog input AI2; ON: \geq P2-16 / OFF: < P2-17 13: STO (Safe Torque OFF) Status Extension of the functionality by a function block \rightarrow P9-35 = 1	1
452.0	P2-16	RO1 Upper Limit	0.0 ... 200.0 %	100.0 %
453.0	P2-17	RO1 Lower Limit	0.0 ... 200.0 %	0.0 %

PNU	Parameter	Name	Range	Default
451.1	P2-18	RO2 Function	0: RUN, enable (FWD/REV) 1: READY, DA1 ready for operation 2: Speed = speed reference value 3: Speed > Speed Zero 4: Speed; ON: \geq P2-19 / OFF: < P2-20 5: Motor current; ON: \geq P2-19 / OFF: < P2-20 6: Motor torque; ON: \geq P2-19 / OFF: < P2-20 7: Analog input AI2; ON: \geq P2-19 / OFF: < P2-20 8: Hoist brake control. (Enables the operating mode for hoists). ON: output frequency \geq P2-07 with START (FWD/REV) command present. OFF: output frequency \leq P2-08 with no START (FWD/REV) command active. 13: STO (Safe Torque OFF) Status Extension of the functionality by a function block \rightarrow P9-36 = 1	0
452.1	P2-19	RO2 Upper Limit	0.0 ... 200.0 %	100.0 %
453.1	P2-20	RO2 Lower Limit	0.0 ... 200.0 %	0.0 %
459.0	P6-04	RO1 n-Hysteresis	0.0 ... 25.0 %	0.3 %
		RO3 Function	fixed: READY, DA1 ready for operation Extension of the functionality by a function block \rightarrow P9-41 = 1	
		RO4 Function	Fixed: Fault Extension of the functionality by a function block \rightarrow P9-41 = 1	
		RO5 Function	Fixed: RUN, enabled (FWD/REV) Extension of the functionality by a function block \rightarrow P9-41 = 1	

3.2.2 User defined extension of the functionality selection

The functionality of the devices DA1 can be adapted and extended by using the function block editor. Parameters P9-35, P9-36 and P9-41 define, if the functionality of the relays is according to the selection with the parameters P2-15 / P2-18, respectively correspond to the factory settings for RO3 ... RO5, or if they are activated by a user defined function block.

PNU	Parameter	Name	Range	Default
497.0	P9-35	RO1 Function Extension	Selection of further functionalities for RO1 0: Function of Relay Output 1 is determined by P2-15 1: User defined output from function block	0
497.1	P9-36	RO2 Function Extension	Selection of further functionalities for RO2 0: Function of Relay Output 2 is determined by P2-18 1: User defined output from function block	0
497.4	P9-41	RO5 Function Extension	Selection of further functionalities for RO3 ... RO5 0: Factory settings active 1: user defined output from function block	0

3.3 Static outputs

3.3.1 Selection of the functionality

The static outputs of the variable frequency drives DA1 can be used as analog as well as digital ones. The changeover between the two modes of operation is done automatically according to the selection of the functionality with P2-11 for ADO1 respectively P2-13 for ADO2.

With the settings P2-11 / P2-13 = 2 or 3 the output indicates, if the motor is at standstill respectively if the motor speed corresponds to the reference value. To prevent a “chatter” of the relay in case of small deviations, one can define a band around the actual speed value with “RO1 n-Hysteresis” (P6-04). If the speed signal is inside the band, it is defined as “speed = zero” respectively “speed = speed reference”.

For the settings P2-11 / P2-13 = 4 ... 7 thresholds for upper and lower limits (Hysteresis) can be defined with parameters P2-16 / P2-17 for ADO1 and P2-19 / P2-20 for ADO2.

PNU	Parameter	Name	Range	Default
468.0	P2-11	ADO1 Function & Mode	P2-11 = 0...7: digital output 0: RUN, enable (FWD/REV) 1: READY, DA1 ready for operation 2: Speed: speed reference value 3: Speed > Speed Zero 4: Speed; ON: \geq P2-16 / OFF: $<$ P2-17 5: Motor current; ON: \geq P2-16 / OFF: $<$ P2-17 6: Motor torque; ON: \geq P2-16 / OFF: $<$ P2-17 7: Analog input AI2; ON: \geq P2-16 / OFF: $<$ P2-17 P2-11 = 8...11: analog output 8: Output frequency (0... 100 % f-max (P1-01)) 9: Motor current (0...200 % Motor rated current (P1-08)) 10: Motor torque (0...200 % Motor rated torque) 11: Motor power (0...200 % Motor rated power) Extension of the functionality by a function block \rightarrow P9-33 = 1	8
452.0	P2-16	RO1 Upper Limit	0.0 ... 200.0 %	100.0 %
453.0	P2-17	RO1 Lower Limit	0.0 ... 200.0 %	0.0 %

PNU	Parameter	Name	Range	Default
468.1	P2-13	ADO2 Function & Mode	<p>P2-13 = 0...7: digital output</p> <p>0: RUN, enable (FWD/REV) 1: READY, DA1 ready for operation 2: Speed: speed reference value 3: Speed > Speed Zero 4: Speed; ON: \geq P2-19 / OFF: < P2-20 5: Motor current; ON: \geq P2-19 / OFF: < P2-20 6: Motor torque; ON: \geq P2-19 / OFF: < P2-20 7: Analog input AI2; ON: > P2-19 / OFF: < P2-20</p> <p>P2-13 = 8...11: analog output</p> <p>8: Output frequency (0... 100 % f-max (P1-01)) 9: Motor current (0...200 % Motor rated current (P1-08)) 10: Motor torque (0...200 % Motor rated torque) 11: Motor power (0...200 % Motor rated power)</p> <p>Extension of the functionality by a function block \rightarrow P9-34 = 1</p>	9
452.1	P2-19	RO2 Upper Limit	0.0 ... 200.0 %	100.0 %
453.1	P2-20	RO2 Lower Limit	0.0 ... 200.0 %	0.0 %
459.0	P6-04	RO1 n-Hysteresis	0.0 ... 25.0 %	0.3 %

3.3.2 User defined extension of the functionality selection

The functionality of the devices DA1 can be adapted and extended by using the function block editor. Parameters P9-33 and P9-34 define, if the functionality of the static outputs is according to the selection with the parameters P2-15 / P2-18, respectively correspond to the factory settings for RO3 ... RO5, or if they are activated by a user defined function block.

PNU	Parameter	Name	Range	Default
499.0	P9-33	ADO1 Function & Mode Extension	<p>Selection of further functionalities for ADO1</p> <p>0: Function of ADO 1 is determined by P2-11 1: User defined digital output (0 V / 24 V) from function block 2: User defined analog output from function block</p>	0
499.1	P9-34	ADO2 Function & Mode Extension	<p>Selection of further functionalities for ADO2</p> <p>0: Function of ADO2 is determined by P2-13 1: User defined digital output (0 V / 24 V) from function block 2: User defined analog output from function block</p>	0

3.3.3 Configuration of the analog outputs

When a static output is defined as analog output (selected with P2-11 respectively P2-13 = 8 ... 11), the output signal can be adapted to the requirements of the application.

	Output ADO1 (Terminal 8)	Output ADO2(Terminal 11)
Signal range	P2-12	P2-14
Scaling	P6-26	-
Offset	P6-27	-

- Signal range: Selection of the kind of signal at the analog outputs (voltage or current)

At ADO1 it is also possible to take a scaling factor and an offset into account.

- Gain: With the gain the analog output can be scaled. It applies to the signal itself as well as to possible offsets.
- Offset: Offset of the analog output. 100 % corresponds to the maximum of the signal selected with P2-12

ATTENTION: the offset is subtracted from signal. Means: positive values result in a reduction, negative ones in an increase.

3.3.3.1 Analog output 1

PNU	Parameter	Name	Range	Default
273.0	P2-12	AO1 SignalFormat	0: 0 ... 10 V (U 0-10) 1: 10 ... 0 V (U 10-0) 2: 0 ... 20 mA (A 0-20) 3: 20 ... 0 mA (A 20-0) 4: 4 ... 20 mA (A 4-20) 5: 20 ... 4 mA (A 20-4)	0
274.0	P6-26	AO1 Scale	0.0 ... 500.0 %	100.0 %
275.0	P6-27	AO1 Offset	-500.0 % ... + 500.0 %	0.0 %

$$\text{Signal at terminal 8} = (\text{Signal selected with P2-11 [\%]} - \text{P6-27}) \cdot \text{P6-26}$$

The value doesn't drop below zero and is limited to 10 V respectively 20 mA.

3.3.3.2 Analogausgang 2

PNU	Parameter	Name	Range	Default
273.1	P2-14	AO2 SignalFormat	0: 0 ... 10 V (U 0-10) 1: 10 ... 0 V (U 10-0) 2: 0 ... 20 mA (A 0-20) 3: 20 ... 0 mA (A 20-0) 4: 4 ... 20 mA (A 4-20) 5: 20 ... 4 mA (A 20-4)	0