

Data Sheet | Item Number: 891-8285/116-201

pre-assembled connecting cable; B2ca; Socket/open-ended; 5-pole; Cod. I; H05Z1Z1-F
5G 1.5 mm²; 2 m; 1,50 mm²; blue

<https://www.wago.com/891-8285/116-201>

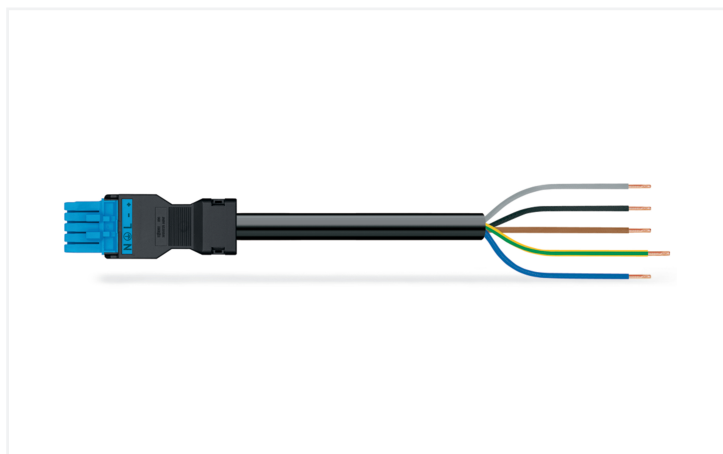

Color: ■ blue

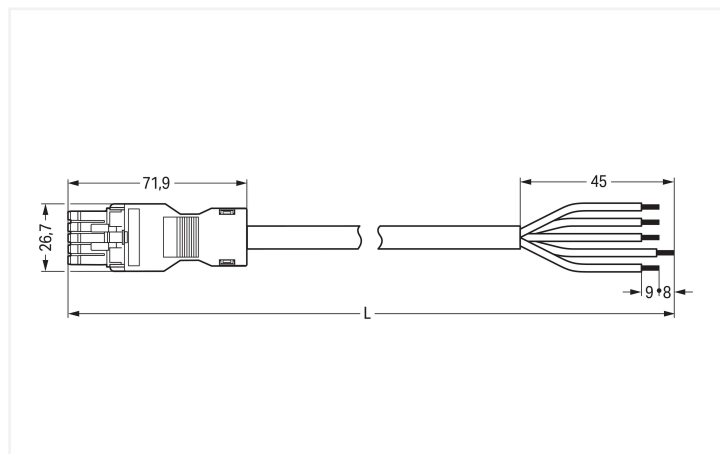

Dimensions in mm

Cable assembly WINSTA® MINI with protection against mismatching

The WINSTA® MINI cable assembly with protection against mismatching is the pluggable solution for your application in control cabinets, for lighting connections or on PCBs. Whether on PCBs, in control cabinets or for connecting lights – pluggable installation connectors from WAGO allow you to establish connections according to many different requirements in seconds. The coding options reduce installation errors, allowing fast, secure wiring of all components. The pluggable installation connector offers protection against contact with tools or wires if they are smaller than 1 mm in accordance with protection type IP40. WINSTA® MINI pluggable installation connectors with I coding in blue are primarily suitable for intelligent, for instance for the dimming function of DALI lights. If only limited space is available, our smallest pluggable connection system, WINSTA® MINI, consistently displays its advantages. It saves space, and, with Push-in CAGE CLAMP® spring pressure connection technology, it also saves time, since the connection is low-maintenance and requires no screw connections. Scrupulous compliance with fire protection regulations is a crucial issue for building installation. Especially in sensitive areas, the fire class must meet extensive requirements. This product complies with the requirements of fire class B2. The cable assembly is free of halogen. This eliminates the addition of environmental pollutants during production. It also increases the fire class, since halogen-free materials do not easily ignite.

Fast, error-free assembly thanks to cable assemblies from WAGO

The cable assembly is equipped with a socket and a free end. WINSTA® is the pluggable connection system that is perfectly tailored to the strict requirements of electrical installation. It offers fast, secure and, above all, error-free installation of components and cables. Choose quality and durability – with fire class B2 from WAGO makes the installation of electrical components noticeably easier.

- pluggable installation connectors with protection against mismatching
- compact design for conductors with a cross-section up to 1.5 mm²
- with I coding for use in building automation (lighting control)
- custom-engineered solutions
- fast, secure installation

Notes

General safety information

1. Only to be used by a qualified electrician or by a person electrically instructed for the task (EIP per DIN VDE 0105-100).
2. Do not install while energized or under load.
3. Use only for its intended purpose.
4. Observe applicable national regulations, standards and directives.
5. Observe the technical specifications of the products.
6. Ensure correct polarity assignment.
7. Do not use damaged or contaminated components.
8. Observe conductor types, conductor cross-sections, strip lengths and cable diameters.
9. Insert conductors up to the stop.
10. Use only with locking lever and strain relief.
11. Use original accessories only.

To be sold only with installation instructions!

Note

Cables with a different fire class can be found in the eShop.

Electrical data

Ratings per	IEC/EN 60664-1		
Overvoltage category	III	III	II
Pollution degree	3	2	2
Nominal voltage	400 V	-	-
Rated impulse withstand voltage	6 kV	-	-
Rated current	16 A	-	-

General information

Note on contact resistance	approx. 1 mΩ of contact resistance approx. 0.25 mΩ contact transition plug/ socket
----------------------------	--

Connection Data

Total number of potentials	5
Conductor preparation	ultrasonically tip-bonded

Connection 1

Strip length	9 mm / 0.35 inches
Pole number	5
Wire cross-section	1.5 mm ²
Strip length (outer insulation)	45 mm
Connection type	Socket - free end

Physical data

Pin spacing	4.4 mm / 0.173 inches
Width	26.7 mm / 1.051 inches
Height	15.8 mm / 0.622 inches
Total length	2 m

Mechanical data

Use	DALI, Lighting Management
Coding	I
Variable coding	No
Marking	N ⊕ L - +
Potential marking	N ⊕ L - +
Mating force of a plug-in connection	approx. 20 ... 70 N (depending on pole number)
Retention force of a plug-in connection	when locked: > 80N
Unmating force of a plug-in connection	when unlocked: approx. 20 ... 70 N (depending on pole number)
Number of mating cycles	200, without resistive load
Connection type	Socket - free end
Type of pre-assembled cable	Connecting cable
Cable type	H05Z1Z1-F 5G1.5
Protection type	IP40

Plug-in connection

Mismating protection	Yes
Note on mismating protection	All <i>WINSTA</i> ® components are 100% protected against mismating when: a.) plugging different numbers of poles b.) plugging while rotated 180 c.) plugging while laterally staggered d.) plugging one pole
Locking lever	Can be retrofitted
Locking of plug-in connection	Locking lever
Note on locking system	All connectors for mounted installations (snap-in versions for lighting fixtures or devices, all types of PCB and distribution connectors) are factory-equipped with locking levers to ensure plugs and sockets are securely locked. Additional locking levers are only required for flying leads (plug/socket).

Material data

Note (material data)	Information on material specifications can be found here
Color	blue
Insulation material (main housing)	Polyamide (PA66)
Fire class per EN 50575	B2 _{ca}
Contact material	Copper or copper alloy; surface-treated
Contact Plating	Tin
Fire load	0.272 MJ
Connector color	blue
Strain relief color	black
Sheathed cable color	black
Printing color of sheathed cable	white
Halogen-free	Yes
Silicon-free	Yes
Sheath material	Halogen-free
Rubber cable	No
Weight	330.6 g
Copper weight of the raw cable	0.072 kg/m

Environmental requirements

Processing temperature	-5 ... +40 °C
Continuous operating temperature	-35 ... +85 °C
Note on continuous operating temperature	Cable for temperatures ≤ 70 °C (including halogen-free) Insulating parts for temperatures ≤ 105 °C

Commercial data

PU (SPU)	1 pcs
Packaging type	unpacked
Country of origin	PL
GTIN	4066966898781
Customs tariff number	85444290900

Product Classification

UNSPSC	26121629
ETIM 10.0	EC002587
ECCN	NO US CLASSIFICATION

Environmental Product Compliance

RoHS Compliance Status	Compliant, No Exemption
------------------------	-------------------------

Downloads

Environmental Product Compliance

Compliance Search

Environmental Product
Compliance
891-8285/116-201



1 Compatible Products

1.1 Required Accessories

1.1.1 Locking system

1.1.1.1 Locking system



Item No.: 890-111

Locking lever; for flying leads; for tool operation; black



Item No.: 890-131

Locking lever; for flying leads; for tool operation; white



Item No.: 890-101

Locking lever; for manual operation; black



Item No.: 890-121

Locking lever; for manual operation; white

1.2 Optional Accessories

1.2.1 Cover

1.2.1.1 Cover



Item No.: 897-2003

Protective cap; Type2; for sockets and plugs; PVC; red

1.2.2 Installation

1.2.2.1 Mounting accessories



Item No.: 890-310

Mounting carrier; 2- to 5-pole; for flying leads; black



Item No.: 890-311

Mounting carrier; 2- to 5-pole; for flying leads; white