

Wilo-DrainLift WS 40/50

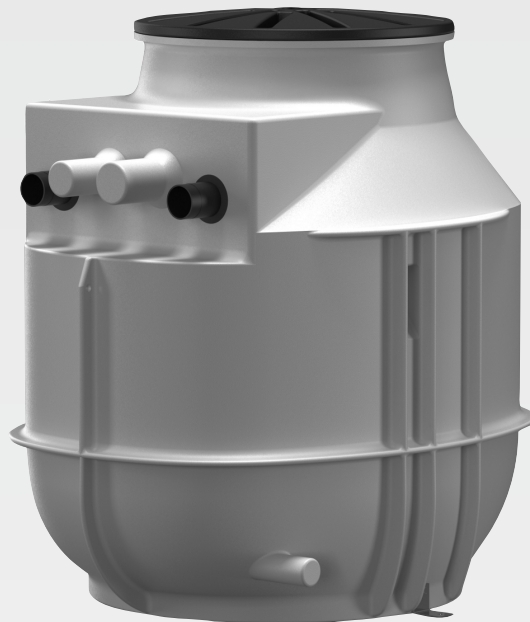

en Installation and operating instructions



DrainLift WS 40/50
<https://qr.wilo.com/752>

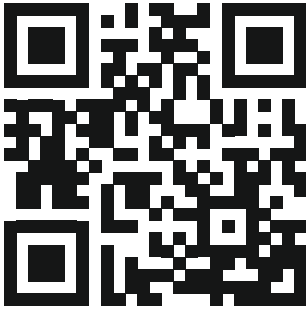

Rexa MINI3-S
<http://qr.wilo.com/413>



Rexa FIT-S
<http://qr.wilo.com/414>



Rexa UNI
<http://qr.wilo.com/796>

Table of contents

1 General information	4	8.4 Clean and disinfect	29
1.1 About these instructions	4	8.5 Pump removal.....	30
1.2 Copyright	4	9 Maintenance and repair	30
1.3 Subject to change	4	10 Spare parts	31
1.4 Exclusion from warranty and liability.....	4	11 Faults, causes and remedies	31
2 Safety	4	12 Disposal	31
2.1 Identification of safety instructions.....	4	12.1 Protective clothing	31
2.2 Personnel qualifications.....	6		
2.3 Electrical connection	6		
2.4 Monitoring devices	6		
2.5 Explosive atmosphere in the collection reservoir	6		
2.6 Transport.....	7		
2.7 Use of lifting equipment	7		
2.8 Installing/dismantling.....	8		
2.9 During operation	8		
2.10 Maintenance tasks.....	8		
2.11 Operator responsibilities.....	8		
3 Application/use	8		
3.1 Intended use	9		
3.2 Improper use.....	9		
4 Product description	9		
4.1 Construction.....	10		
4.2 Technical data	10		
4.3 Pump chamber extension	10		
4.4 Materials	10		
4.5 Type key	10		
4.6 Scope of delivery.....	10		
4.7 Accessories	11		
5 Transportation and storage	11		
5.1 Delivery.....	11		
5.2 Transport.....	11		
5.3 Transport with lifting accessories	11		
5.4 Storage	12		
6 Installation and electrical connection	12		
6.1 Personnel qualifications.....	12		
6.2 Installation types.....	12		
6.3 Operator responsibilities.....	12		
6.4 Installation – building installation (above ground).....	13		
6.5 Installation – ground installation (under ground).....	22		
6.6 Electrical connection	26		
7 Commissioning	26		
7.1 Personnel qualifications.....	27		
7.2 Operator responsibilities.....	27		
7.3 Operation	27		
7.4 Test run	27		
7.5 Operation	28		
7.6 During operation	28		
8 Shut-down/dismantling	28		
8.1 Personnel qualifications.....	28		
8.2 Operator responsibilities.....	28		
8.3 Shut-down.....	29		

1 General information

1.1 About these instructions

These instructions form part of the product. Compliance with the instructions is essential for correct handling and use:

- Read the instructions carefully before all activities.
- Keep the instructions in an accessible place at all times.
- Observe all product specifications.
- Observe the markings on the product.

The language of the original operating instructions is German. All other languages of these instructions are translations of the original operating instructions.

1.2 Copyright

WILO SE © 2023

Reproduction, distribution and utilisation of this document in addition to communication of its contents to others without express authorisation is prohibited. Offenders will be held liable for payment of damages. All rights reserved.

1.3 Subject to change

Wilo shall reserve the right to change the listed data without notice and shall not be liable for technical inaccuracies and/or omissions. The illustrations used may differ from the original and are intended as an exemplary representation of the product.

1.4 Exclusion from warranty and liability

Wilo shall specifically not assume any warranty or liability in the following cases:

- Inadequate configuration due to inadequate or incorrect instructions by the operator or the client
- Non-compliance with these instructions
- Improper use
- Incorrect storage or transport
- Incorrect installation or dismantling
- Insufficient maintenance
- Unauthorised repairs
- Inadequate construction site
- Chemical, electrical or electrochemical influences
- Wear

2 Safety

This section contains basic information about the individual stages in the life cycle of the pump. Failure to observe this information leads to:

- Danger to persons
- Danger to the environment
- Property damage
- Loss of claims for damages

2.1 Identification of safety instructions

These installation and operating instructions set out safety instructions for preventing personal injury and damage to property. These safety instructions are shown differently:

- Safety instructions relating to personal injury start with a signal word, are **preceded by a corresponding symbol** and are shaded in grey.



DANGER

Type and source of the danger!

Consequences of the danger and instructions for avoidance.

- Safety instructions relating to property damage start with a signal word and are displayed **without** a symbol.

CAUTION

Type and source of the danger!

Consequences or information.

Signal words

- **DANGER!**
Failure to observe the safety instructions will result in serious injuries or death!
- **WARNING!**
Failure to follow the instructions can lead to (serious) injuries!
- **CAUTION!**
Failure to follow the instructions can lead to property damage and a possible total loss.
- **NOTICE!**
Useful information on handling the product

Symbols

These instructions use the following symbols:



Danger caused by electric voltages



Danger of explosion



Personal protective equipment: wear a safety helmet



Personal protective equipment: wear safety footwear



Personal protective equipment: Wear protective gloves



Personal protective equipment: Wear safety glasses



Personal protective equipment: Wear face mask



General command symbol – follow instructions



Useful information

Markups

- ✓ Prerequisite
- 1. Work step/list
 - ⇒ Notice/instructions
 - ▶ Result

Identifying cross references

The name of the section or table is in inverted commas [“ ”]. The page number follows in square brackets [].

2.2 Personnel qualifications

- Personnel have been instructed on locally applicable regulations governing accident prevention.
- Personnel have read and understood the installation and operating instructions.
- Installation/dismantling work: trained specialist in plant technology for sanitary facilities
Fixation and buoyancy safeguards, connection of plastic pipes
- Ground installation (underground): trained specialist in underground and pipeline construction
Excavate and prepare the pit, backfill the pit, buoyancy safeguards, connection of plastic pipes.
- Electrical work: qualified electrician
Person with appropriate technical training, knowledge and experience who can identify and prevent electrical hazards.
- Maintenance work: skilled person (trained specialist in plant technology for sanitary facilities)
Hazards caused by sewage, basic knowledge of lifting units, requirements of EN 12056
- Lifting work: trained specialist for the operation of lifting devices
Lifting equipment, lifting gear, attachment points

Children and persons with limited abilities

- Persons under the age of 16: Use of this product is prohibited.
- Persons under the age of 18: Supervise them during use of the product (supervisor)!
- Persons with limited physical, sensory or mental capacities: Use of this product is prohibited!

2.3 Electrical connection

- Establish the electrical connection according to the instructions for the devices used.
- Earth all electrical devices according to local regulations!

2.4 Monitoring devices

The pump chamber is used to collect sewage. In the event of a fault in the system, the sewage can become backed up to the inlet. In serious cases, the pump chamber can overflow.

The installation of a high water alarm is recommended to ensure operational reliability. For increased safety, the high water alarm should be reported via GSM or fieldbus.

2.5 Explosive atmosphere in the collection reservoir

Sewage containing faeces can lead to gas accumulations in the tank. These gas accumulations can escape into the operating space and create an explosive atmosphere as a result of incorrect installation or maintenance work. This atmosphere can ignite and

lead to an explosion. In order to prevent an explosive atmosphere, observe the following points:

- Tank must be undamaged (no cracks, leaks, porous material)! Take any defective lifting units out of operation.
- Connect all connections for inlet, discharge line and venting line in accordance with regulations and tightly!
- Guide the venting line over the roof.
- When opening the tank (e.g. during maintenance work), ensure appropriate exchange of air!

2.6 Transport

- Locally applicable laws and regulations on work safety and accident prevention must be complied with.
- Demarcate and cordon off the working area.
- Keep unauthorised persons away from the working area.
- Transport the pump chamber on a pallet.
- Set down the pump chamber vertically.
To avoid damage to the pipework and pipe adaptors, keep the pump chamber vertical during transport.
- Secure the pump chamber against slipping and falling over.
When lashing, make sure that the plastic parts do not deform.
- Remove loose components from the product.

2.7 Use of lifting equipment

If lifting equipment (lifting device, crane, chain hoist ...) is used, observe the following points:

- Wear a safety helmet according to EN 397!
- Comply with local regulations on the use of lifting equipment.
- The technically correct use of the lifting equipment is the operator's responsibility!
- **Lifting gear**
 - Use legally specified and approved lifting gear.
 - Select lifting gear based on the attachment point.
 - Attach lifting gear to the attachment point according to local regulations.
- **Lifting equipment**
 - Check its functions properly before use!
 - Sufficient bearing capacity.
 - Ensure stability during use.
- **Lifting operation**
 - Do not jam the product when lifting and lowering it.
 - Do not exceed the max. permissible bearing capacity!
 - If necessary (e.g. blocked view), assign a second person to coordinate.
 - No one should stand under suspended loads!
 - Do not move loads over workplaces where persons are present!

2.8 Installing/dismantling

- Locally applicable laws and regulations on work safety and accident prevention must be complied with.
- Demarcate and cordon off the working area.
- Keep unauthorised persons away from the working area.
- Remove objects lying around from the work area.
- If the weather conditions mean it is no longer possible to work safely, stop work.
- Close the inlet and pressure pipe.
- Work must always be carried out by two persons.
- Toxic or asphyxiating gases may build up in enclosed spaces or buildings. Observe protective measures in accordance with work regulations, e.g. carry a gas detector with you.

2.9 During operation

- Open all gate valves in the inlet and pressure pipe!
- The maximum intake must be lower than the maximum output of the system.
- Do not open the inspection openings!
- Ensure chamber ventilation!

2.10 Maintenance tasks

- Close the inlet and pressure pipe.
- Only carry out maintenance tasks described in these installation and operating instructions.
- Only original parts of the manufacturer may be used. The use of any non-original parts releases the manufacturer from any liability.
- Collect any leakage of fluid and operating fluid immediately and dispose of it according to the locally applicable guidelines.

Installed pumps and accessories

- Disconnect devices from the mains supply and secure against being switched on again without authorisation.
- Carry out maintenance work according to the instructions of the products.

2.11 Operator responsibilities

- Provide installation and operating instructions in a language which the personnel can understand.
- Make sure that the personnel have received the required training for the specified work.
- Provide protective equipment. Ensure that the protective equipment is worn by personnel.
- Ensure that safety and information signs mounted on the device are always legible.
- Train the personnel on how the system operates.
- Demarcate and cordon off the working area.

3 Application/use

3.1 Intended use

CAUTION

Overpressure in the tank can cause the tank to burst!

Observe the following points to prevent overpressure in the tank:

- The maximum positive suction head of the lowest inlet is 5 m (16.5 ft).
- The maximum inlet volume is smaller than the maximum volume flow at the duty point!

Application

- As a lifting unit within buildings (above ground installation).
- As a pump chamber outside buildings (concealed floor installation).
- For backflow resistant drainage of
 - Drainage points below the backflow level
 - Drainage points that cannot be drained via the natural downward slope.

Fluid

For collection and pumping of the following in commercial areas:

- Sewage containing faeces

NOTICE! Install grease traps upstream of the pump chamber if pumping greasy sewage!

Sewage pumping according to 12050

- DIN EN 12050-1:
 - DrainLift WS 40E/D with Rexa PRO-S ...
- EN 12050-1:
 - DrainLift WS 40E/D with Rexa MINI3-S ...
 - DrainLift WS 40E/D with Rexa FIT-S ...
 - DrainLift WS 50E/D with Rexa UNI ...

3.2 Improper use



DANGER

Explosion due to use of explosive fluids!

Use of highly flammable and explosive fluids (gasoline, kerosene, etc.) in their pure form is prohibited. There is a risk of fatal injury due to explosion!

Do **not** use the following fluids:

- Sewage from drainage objects that are located above the backflow level and can be drained by natural fall.
- Debris, ash, rubbish, glass, sand, plaster, cement, lime, mortar, fibrous materials, textiles, paper towels, wet-wipes (e.g. fleece cloths, moist toilet paper wipes), nappies, cardboard, coarse paper, synthetic resins, tar, kitchen waste, grease, oil
- Slaughterhouse waste, disposal of slaughtered animals and animal waste (liquid manure etc.)
- Toxic, aggressive and corrosive fluids, such as heavy metals, biocides, pesticides, acids, bases, salts, swimming-pool water
- Cleaning agents, disinfectants, dishwashing or laundry detergents in excess amounts, and such that have a disproportionately high degree of foam formation
- Drinking water

Intended use also includes compliance with this manual. Any other use is regarded as non-compliant with intended use.

4 Product description

4.1 Construction

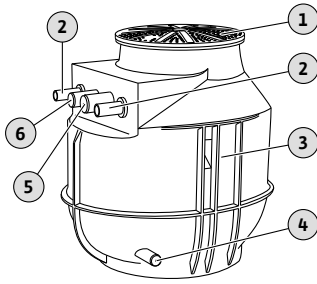

Fig. 1: Structure

Plastic chamber with pipework, for connecting one or two pumps. Suitable for ground installation or building installation.

1	Chamber cover
2	Pressure pipe connection
3	Pump chamber
4	Drain pipe/diaphragm hand pump connection
5	Venting line connection
6	Cable pipe connection

Chamber

Pump chamber with optimised geometry for deposit-free operation. Chamber component with finning for high inherent stability and anti-buoyancy. The inlets are freely configurable. Two lifting eyes are integrated for attaching the lifting accessory. The upward curved pump chamber cover can be walked on and can be loaded with max. 200 kg. For the building installation, the pump chamber is equipped with a floor fixation.

Pipework

- Discharge pipe with flange connection on the pump side
- Gate valve
- Surface coupling
- Non-return ball valve (integrated in the surface coupling)
- Vessel volume: 255 l/67 US.liq.gal. (WS...E)/400 l/105 US.liq.gal. (WS...D)
- Maximum pressure in the discharge line: 6 bar (87 psi)
- Pressure connection: R 1½ (WS 40), R 2 (WS 50)
- Inlet connection: DN 100/150/200
- Ventilation connection: 75 mm (3 in)
- Cable pipe for ground installation: 63 mm (2.5 in)
- Threaded cable glands for building installation:
 - WS 40E .../WS 50E ...: 1x M25 + 2x M16
 - WS 40D .../WS 50D ...: 2x M25 + 2x M16
- Fluid temperature: 3 ... 40 °C (37 ... 104 °F)
- Max. ambient temperature: 3 ... 40 °C (37 ... 104 °F)
- Max. groundwater level: 500 mm (20 in)

4.2 Technical data

4.3 Pump chamber extension

	DrainLift WS 40E ... DrainLift WS 50E ...	DrainLift WS 40D ... DrainLift WS 50D ...
Pump chamber extension height	300 mm (12 in)	300 mm (12 in)
Pump chamber total height	1342 mm (53 in)	1342 mm (53 in)
Max. vessel volume	325 l (86 US.liq.gal)	470 l (124 US.liq.gal)
Max. groundwater level	1000 mm (39 in)	500 mm (20 in)

4.4 Materials

- Pump chamber: PE
- Pipework: 1.4404 (AISI 316L)
- Surface coupling: PUR
- Non-return valve: PUR
- Gate valve: Red brass

4.5 Type key

Example:	DrainLift WS 40E
DrainLift	Product family
WS	Pump chamber
40	Size
E	Chamber design: <ul style="list-style-type: none"> • E = single pump chamber • D = double pump chamber

4.6 Scope of delivery

- Plastic chamber with installed pipework
 - Pipework with gate valve and surface coupling with integrated non-return valve
- Chamber cover with gasket

4.7 Accessories

- HT double socket 50 mm (2 in) for evacuation connection
- Inlet set with hole saw 124 mm (5 in) and gasket DN 100
- Floor fixation
- Installation and operating instructions
- Pump chamber extension
- Clamp bolting
- Gate valve
- Inlet set (gasket and hole saw)
- Diaphragm hand pump
- Switchgear
- Float switch
- Level sensor
- Zener barrier
- Ex cut-off relay
- Alarm switchgear
- Flash light
- Horn

5 Transportation and storage

5.1 Delivery

- After receiving the shipment, check it immediately for defects (damage, completeness).
- Defects must be noted on the freight documentation.
- Defects must be notified to the transport company or the manufacturer on the day of receipt of shipment.
- Subsequently notified defects can no longer be asserted.

5.2 Transport

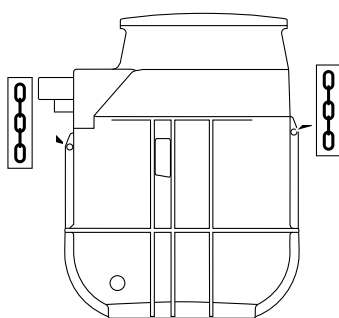

Fig. 2: Slings points

- Wear protective equipment! Observe the work regulations.
 - Protective gloves: 4X42C (uvex C500 wet)
 - Safety shoes: Protection class S1 (uvex 1 sport S1)
- Transport the pump chamber on a pallet.
- Set down the pump chamber vertically.

To avoid damage to the pipework and pipe adaptors, keep the pump chamber vertical during transport.
- Secure the pump chamber against slipping and falling over.

When lashing, make sure that the plastic parts do not deform.
- Close any openings, ensuring they are sealed watertight.
- Remove loose accessories from the pump chamber and pack them separately.

NOTICE! Thoroughly clean used pump chambers before shipping and disinfect them!

5.3 Transport with lifting accessories

If lifting accessories (lifting equipment, crane, chain hoist ...) are used, observe the following points:

- Wear a safety helmet according to EN 397!
- Comply with local regulations on the use of lifting equipment.
- The technically correct use of the lifting accessory is the operator's responsibility!
- **Lifting slings**
 - Use legally specified and approved lifting slings.
 - Select lifting slings based on the slinging point.
 - Attach lifting slings to the slinging point according to local regulations.
- **Lifting accessories**
 - Check it functions properly before use!
 - Sufficient bearing capacity.
 - Ensure stability during use.
- **Lifting operation**
 - Do not jam the product when lifting and lowering it.
 - Do not exceed the max. permissible bearing capacity!
 - If necessary (e.g. blocked view), assign a second person to coordinate.
 - No one should stand under suspended loads!
 - Do not move loads over workplaces where persons are present!

5.4 Storage



DANGER

Danger of death from fluids hazardous to health!

Danger of bacterial infection!

- Disinfect the pump chamber after draining and before removal!
- Observe the specifications of the factory regulations!

- Drain the pump chamber completely.
- Place the pump chamber on a firm surface. Check the stability.
- Secure the pump chamber against falling over and slipping!
- Storage conditions:
 - Maximum: -15 ... 60 °C (5 ... 140 °F), max. humidity: 90 %, non-condensing.
 - Recommended: 5 ... 25 °C (41 ... 77 °F), relative humidity: 40 ... 50 %.
- Close all openings, ensuring they are sealed watertight.
- Do not store the pump chamber in spaces where welding work is carried out. The resulting gases or radiation can corrode the plastic parts.
- Protect the pump chamber from direct exposure to sunlight. Extreme heat can cause the plastic parts to deform!

If pumps or signal transmitters are installed, please also observe the following points:

- Seal the ends of the connection cables against water ingress.
- Coil up connection cables and attach in the pump chamber.
- Observe information on the max. storage temperature of the pumps and signal transmitters.
- Store the switchgear according to the manufacturer's instructions.

6 Installation and electrical connection

6.1 Personnel qualifications

- Installation/dismantling work: trained specialist in plant technology for sanitary facilities
Fixation and buoyancy safeguards, connection of plastic pipes
- Ground installation (underground): trained specialist in underground and pipeline construction
Excavate and prepare the pit, backfill the pit, buoyancy safeguards, connection of plastic pipes.
- Lifting work: trained specialist for the operation of lifting devices
Lifting equipment, lifting gear, attachment points
- Personnel have been instructed on locally applicable regulations governing accident prevention.
- Personnel have read and understood the installation and operating instructions.

6.2 Installation types

- Installation (above ground) inside buildings
- Ground installation (below ground) outside buildings

6.3 Operator responsibilities

- Observe locally applicable accident prevention and safety regulations.
- Observe all regulations for working with heavy loads and under suspended loads.
- Provide protective equipment. Ensure that the protective equipment is worn by personnel.
- Observe local sewage technology regulations for the operation of sewage systems.
- Structural components and foundations must be of sufficient stability in order to allow the device to be fixed in a secure and functional manner. The operator is responsible for the provision and suitability of the structural component/foundation!
- Demarcate the working area.
- Keep unauthorised persons away from the working area.
- Ensure free access to the installation location.
- Horizontal and flat installation surface!
- Carry out the installation work according to locally applicable regulations.
- If the weather conditions (e.g. ice formation, strong wind) mean it is no longer possible to work safely, stop work.
- Check that the available consulting documents (installation plans, installation location, inflow conditions) are complete and accurate.
- Lay and prepare the pipes according to the consulting documents.

6.4 Installation – building installation (above ground)



DANGER

Danger due to fluids hazardous to health during installation!

Danger of bacterial infection!

- Clean and disinfect installation location.
- Wipe up drips immediately.
- Observe the specifications of the factory regulations!
- If contact with fluids that are hazardous to health is possible, wear the following protective equipment:
 - sealed safety glasses
 - mouth protection
 - safety gloves



DANGER

Risk of fatal injury due to dangerous lone working practices!

Work in chambers and narrow rooms as well as work involving risk of falling are dangerous work. Such work may not be carried out autonomously!

- Only carry out work with another person!



NOTICE

Installation of the pump chamber inside buildings

Observe EN 12056 and local regulations during installation!

- Wear protective equipment! Observe the work regulations.
 - Protective gloves: 4X42C (uvex C500 wet)
 - Safety shoes: Protection class S1 (uvex 1 sport S1)
- Prepare the installation site:
 - Clean, free of coarse solids
 - Dry
 - Frost-free
 - Well lit
- Ensure operating space has sufficient ventilation.
- If toxic or asphyxiating gases accumulate, leave the workplace immediately!
- Ensure a clearance area of min. 60 cm (2 ft) around the unit.
- In the event of an accident: Provide pump sump in the operating space, min. dimensions: 500x500x500 mm (20x20x20 in). Select pump accordingly. Ensure that manual drainage is possible.
- All connection cables must be laid properly. The connection cables must not pose any risk (i.e. tripping, damage during operation). Check whether the cable cross-section and the cable length are sufficient for the selected installation type.
- Installation of switchgear: Observe information in the manufacturer's instructions (IP class, overflow-proof, potentially explosive atmospheres)!

6.4.1 Note on fixation material

The lifting unit can be installed on various constructions (concrete, steel construction etc.). Select the fixation material which is suitable for the relevant construction. For correct installation, observe the following instructions for the fixation material:

- Avoid tearing or chipping of the construction surface, **observe the minimum edge distances.**
- Ensure tight and secure installation, **adhere to the prescribed borehole depth.**
- Drilling dust impairs holding strength, **always blow out or vacuum out the borehole.**
- Only use components (e.g. screws, anchors, mortar cartridges) which are in perfect condition.

6.4.2 Note on pipework

The pipework is subjected to different pressures during operation. Pressure peaks can also occur (e.g. when closing the swing check valve) which may be several times higher than the pump pressure, depending on the operating conditions. These different pressures put a

strain on the piping and the pipe adaptors. In order to ensure safe and faultless operation, the piping and pipe adaptors must be checked based on the following parameters and designed according to the requirements:

- On-site pipes are self-supporting.
No tensile or compressive forces may act on the lifting unit.
- Pressure resistance of pipework and pipe adaptors
- Tensile strength of the pipe adaptors (= longitudinal force fit connection)
- Connect the pipes free of stress and oscillations.
- Provide a gate valve in the inlet and the discharge line on-site!

6.4.3 Work steps

The pump chamber is installed in the following steps:

- Preparatory tasks.
- Install the pump chamber.
- Connect the pressure pipe.
- Connect the inlet.
- Connect the vent.
- Connect the emergency drain.
- Install the pump.
- Install the level control device.
- Lay the connection cable.
- Fit the chamber cover.

6.4.4 Preparatory tasks

- Unpack the pump chamber.
- Remove the securing mechanisms.
- Check the scope of delivery.
- Prepare the installation location:
 - Horizontal and flat installation surface!
 - Space for an additional clearance area of at least 60 cm (2 ft) provided!
 - Fixation with dowels possible.
 - Clean, free of coarse solids
 - Dry
 - Frost-free
 - Well lit
- Keep accessories available for later use:
 - Chamber cover
 - Y-piece
 - The pump chambers WS 40 ... D and WS 50 ... D have separate pipework for each pump. They therefore also have two discharge ports.
 - NOTICE! Y-piece to be provided on-site!**
 - Switchgear
 - Level control

6.4.5 Install the pump chamber

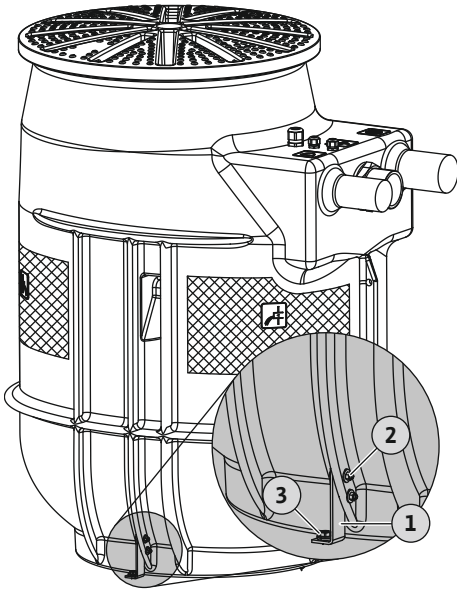

Fig. 3: Install the pump chamber

1	Mounting bracket (2 pieces)
2	Fixation for mounting bracket: <ul style="list-style-type: none"> • 4x M5x25 hexagon head screw • 4x M5 hexagon nut • 8x washers
3	Floor fixation: <ul style="list-style-type: none"> • 2x SXRL 10x80FUS long-shaft dowel • 2x 7 mm hexagon head screw

Install pump chamber so as to protect against buoyancy and twisting. Anchor the lifting unit to the floor for this.

- ✓ Preparatory tasks have been completed.
- ✓ Installation location prepared according to consulting documents.
- ✓ Enclosed fixation material: Observe the information on the building ground! If necessary, provide suitable fixation material for the floor fixation on-site.
- ✓ SW8 and SW13 wrench

1. Place the pump chamber at the installation site and align it with the on-site pipework.
NOTICE! The pump chamber must be vertical!
2. Mount the mounting brackets on the chamber ribs (Item 2).
3. Mark the boreholes.
4. Place the pump chamber to one side.
5. Drill and clean the boreholes.
6. Insert wall plugs (Item 3)
7. Align the pump chamber with the boreholes.
8. Attach the pump chamber to the floor (Item 3).
 - ▶ Pump chamber installed so as to protect against buoyancy and twisting.
 - ▶ Next step: Connect the pressure pipe.

6.4.6 Connecting the pressure pipe

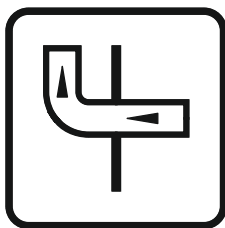
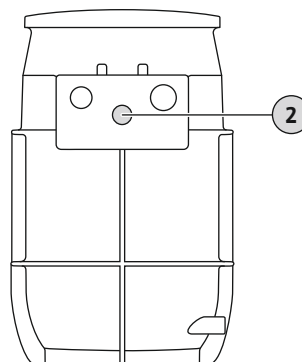

Fig. 4: Labelling on the pump chamber

DrainLift WS 40E/50E



DrainLift WS 40D/50D

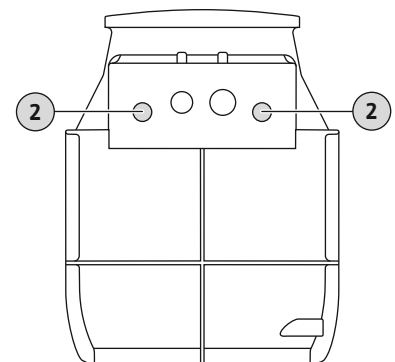

Fig. 5: Discharge port

2	Discharge port
---	----------------

Observe the following information when connecting the pressure pipe:

- Flow rate in the pressure pipe: 0.7 m/s (2.3 ft/s) to 2.3 m/s (7.5 ft/s)!
- Reducing the pipe diameter is not permitted!
- All connections must be completely tight!
- Lay the pressure pipe so that it is protected from frost.
- Install the gate valve.

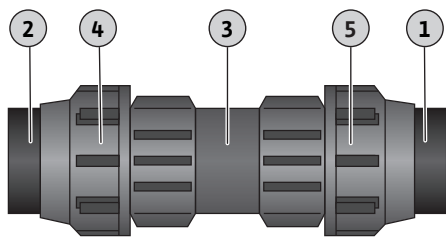

Fig. 6: Connecting the pressure pipe

1	Pump chamber discharge outlet
2	Discharge line, on-site
3	Clamp bolting, fixed part
4	Clamp bolting, clamp ring
5	Clamp bolting with female thread 2½"

- ✓ Pump chamber installed properly.
 - ✓ Pressure pipe installed correctly to the discharge port according to consulting documents.
 - ✓ Installation material DrainLift WS 40E/WS 50E: 1x clamp bolting or threaded fitting, to be provided on-site.
 - ✓ Installation material DrainLift WS 40D/WS 50D: 2x clamp bolting or threaded fittings and Y-piece, to be provided on-site
1. Loosen the clamp ring, do not unscrew.
 2. Screw the clamp bolting onto the discharge outlet.
 3. Insert the discharge line into the clamp bolting as far as it will go.
 4. Tighten the union nut and clamp ring firmly.
 5. Tighten the clamp ring firmly.
 - ▶ Pressure pipe connected.
 - ▶ Next step: Connect the inlet.

6.4.7 Connect the inlet

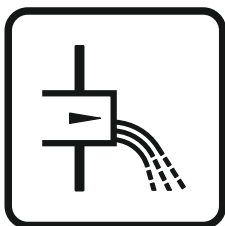

Fig. 7: Labelling on the pump chamber

The inlet can be in the areas indicated for the chamber wall, as desired.

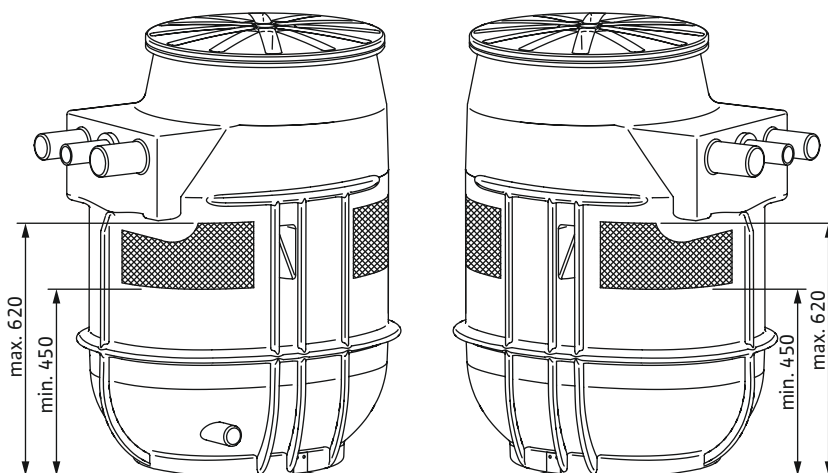

Fig. 8: Inlet areas

Note the following when connecting the inlet:

- Connect the inlet within the marked areas. If the inlet is outside the marked areas, the following problems can occur:
 - The connection leaks.
 - Statics of the pump chamber are affected.
 - Backflow into the inlet pipe.
- Avoid an inlet surge and air intake into the pump chamber. Lay the inlet properly.

CAUTION! Inlet surges or air intake into the pump chamber can cause the level control device to malfunction!
- Lay the inlet pipe with a slope to the pump chamber so that it can drain automatically.
- All connections must be completely tight!
- Install gate valve in the inlet!

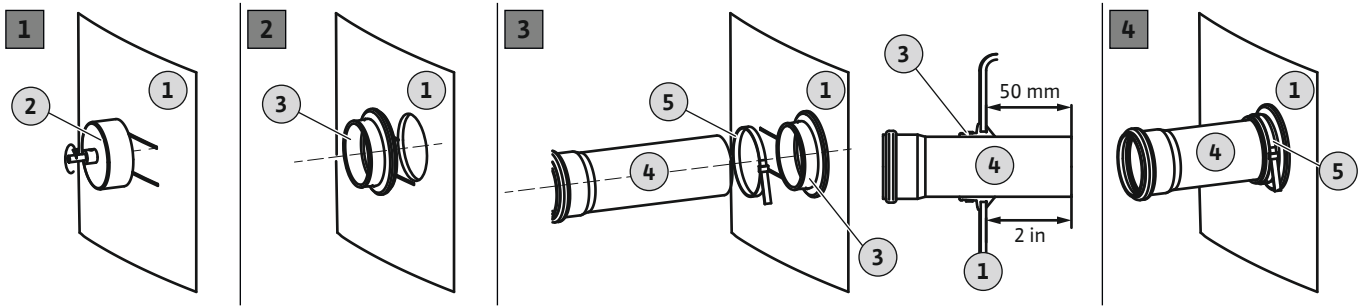

Fig. 9: Connecting the inlet

1	Tank wall
2	Hole saw for drill
3	Inlet seal
4	Inlet pipe
5	Pipe clamp

- ✓ Pump chamber installed properly.
 - ✓ Inlet pipe installed properly up to the pump chamber and according to consulting documents.
 - ✓ Installation materials provided:
 - 1x hole saw
 - 1x drill
 - 1x inlet seal
 - 1x pipe clamp
1. Mark the inlet point on the pump chamber.
 2. Use the supplied hole saw to cut the hole for the inlet into the pump chamber wall. When drilling holes on the pump chamber, observe the following points:
 - Observe the dimensions of the inlet surfaces. **CAUTION! The drilled hole must be completely within the marked inlet surfaces!**
 - Max. speed of the drill: 200 rpm.
 - Check the hole diameter: DN 100 = 124 mm (5 in). **NOTICE! Drill the connection carefully. Impermeability of the connection depends on the quality of the drilled hole!**
 - Make sure the excess material in the drill bit is removed completely! If the excess material removal rate decreases, the material will heat up too quickly and melt.
 - ⇒ Stop the drilling process, allow the material to cool down and clean the hole saw!
 - ⇒ Reduce the speed of the drill.
 - ⇒ Vary the feed pressure when drilling.
 3. Deburr and smooth the cut surface.
 4. Insert the inlet seal into the hole.
 5. Push the pipe clamp onto the inlet seal.
 6. Coat the inner surface of the inlet seal with lubricant.
 7. Push the inlet pipe into the inlet seal. Push the inlet pipe 50 mm (2 in) into the pump chamber.
 8. Connect the inlet seal and pipe firmly to the pipe clamp. **Tightening torque: 5 Nm (3.7 ft·lb).**
 - ▶ Inlet connected.
 - ▶ Next step: Connect the vent.

6.4.8 Connecting the vent

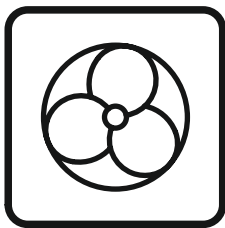
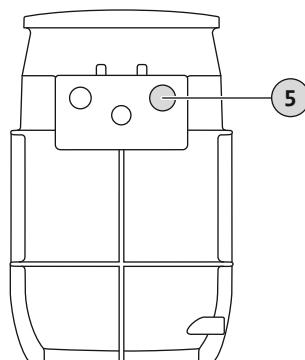

Fig. 10: Labelling on the pump chamber

The connection of a venting line is a specified requirement. Observe the following points when connecting the venting line:

- Guide the venting line over the roof.
- All connections must be completely tight.

DrainLift WS 40E/50E



DrainLift WS 40D/50D

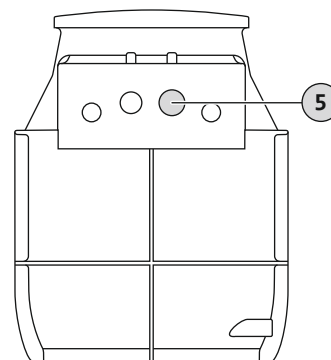

Fig. 11: Venting connection

5 Venting line connection

- ✓ Pump chamber is installed properly.
 - ✓ On-site venting line professionally installed.
 - ✓ HT sleeve socket available
1. Open the venting connection piece: Sawing edge approx. 25 mm.
 2. Deburr and smooth the sawing edge.
 3. Place the HT sleeve socket onto the venting connection piece.
 4. Insert the on-site venting pipe into the HT sleeve socket.
 - ▶ Venting installed.
 - ▶ Next step: Connect the emergency drain.

6.4.9 Connect the emergency drain



NOTICE

Do not connect inlet to the emergency drain!

The pump chamber is pumped out via the emergency drain in the event of an accident. Provide for the emergency drain. The pump chamber cannot be drained in case of emergency otherwise!

- Do not connect inlets to the emergency drain!

In case of maintenance work or pump malfunction, the pump chamber can be emptied via the emergency drain. It is recommended to install a diaphragm hand pump for this purpose.

CAUTION! If the pumps malfunction, there is backflow into the inlet and the pump chamber can burst! Shut off the inlet and drain the pump chamber.

DrainLift WS 40E/50E

DrainLift WS 40D/50D

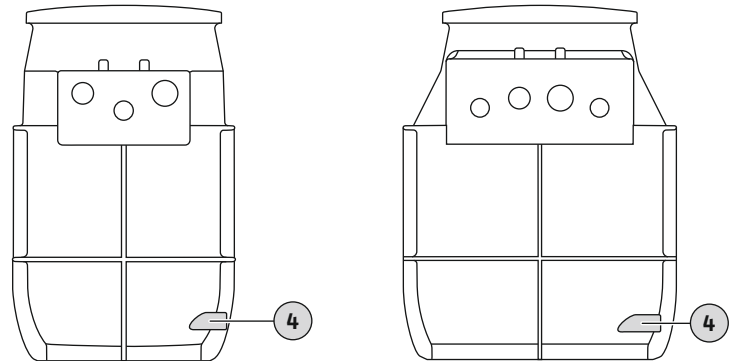

Fig. 12: Emergency drain connection

4	Emergency drain connection
---	----------------------------

Observe the following points when installing a diaphragm hand pump:

- Select an installation height which is optimal for operation.
- Connect the diaphragm hand pump to the emergency drain (lowest point, almost complete drain possible).
- A hole saw 30 mm (1.3 in) is required to open the drain connection.
- Connect the pressure pipe downstream of the gate valve on the pressure side. Alternatively, the connection can be made via a pipe loop directly to the sewer.
- All connections must be completely tight!
- Observe the installation and operating instructions for the diaphragm hand pump!

6.4.10 Install the pump

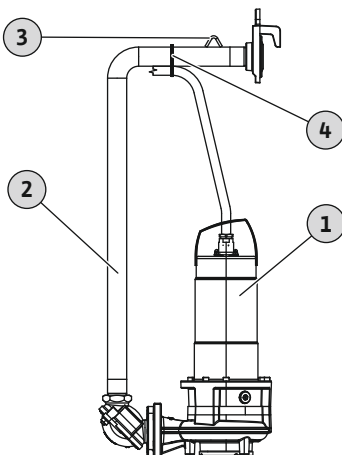

Fig. 13: Install the pump

1	Pump
2	Discharge pipe
3	Sliding point
4	Cable tie

✓ On-site piping connected.

1. Pump any existing water out of the pump chamber.
2. Remove coarse contaminants in the pump chamber.
3. Uncouple the discharge pipe from the surface coupling and lift it out of the pump chamber.
4. Screw the discharge pipe to the pump with the enclosed installation material.
5. Attach the connection cable to the horizontal part of the discharge pipe using the cable tie supplied. Run the cable from the pump to the cable tie with slight tension and with no slack.
6. Attach the hoisting chain to the discharge pipe at the slinging point.
7. Attach the hoisting chain to the lifting accessory.
8. Lower the pump and discharge pipe into the chamber.

CAUTION! If the pump and discharge pipe are drained, do not bump into and get stuck on the chamber fittings. Depending on the pump type, turn the pump 90° when draining.
9. Couple the discharge pipe into the surface coupling.
10. Disconnect the hoisting chain from the lifting accessory and hang it on the chain hook in the pump chamber.
 - ▶ Pump installed. Next step: Install the level control device.

6.4.11 Install the level control device

The level can be measured in the following ways:

- Level sensor
- Float switch

NOTICE! The switchgear must have the correct inputs for the selected signal transmitters!

6.4.11.1 Float switch

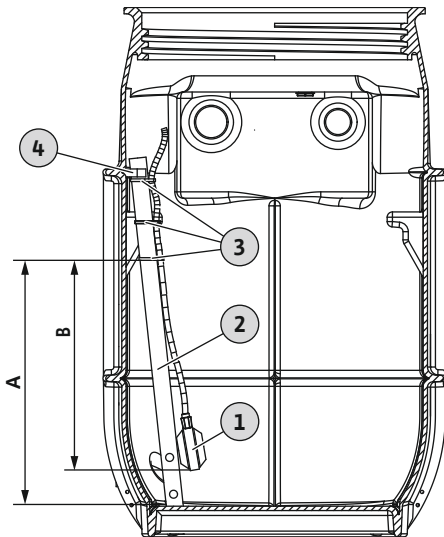

Fig. 14: Float switch installation

1	Float switch
2	Retaining pipe
3	Cable tie
4	Pipe clamp to fix the retaining pipe

- ✓ Do not install the floater directly in the inlet.
- ✓ Floater has sufficient freedom of movement.
- ✓ Floater does not bump against the pump chamber.

1. Click the retaining pipe out of the pipe clamp and remove it from the pump chamber.
2. Float switch attached to the retaining pipe with three cable ties. Observe the cable length and mounting height!
3. Reinstall the retaining pipe in the pump chamber and clip it into the pipe clamp.

DrainLift	Attachment point Cable tie (A)*	Cable length Floater (B)*
WS 40 ...	460 mm (18 in)	380 mm (15 in)
WS 50 ...	460 mm (18 in)	380 mm (15 in)

* The values refer to an inlet floor of 450 mm (17.5 in). The value can be adjusted if the inlet is higher.

NOTICE! For increased operational reliability, install a separate float switch for high water detection! In order to prevent a backflow in the inlet pipe, set the high water alarm at the height of the inlet floor.

6.4.11.2 Level sensor

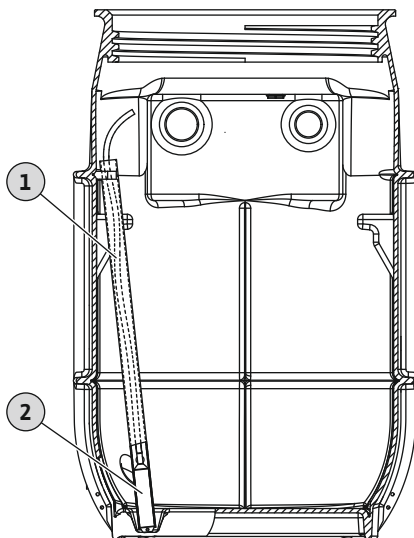

Fig. 15: Level sensor installation

1	Retaining pipe
2	Level sensor

- ✓ To prevent backflow in the inlet pipe, set the switching point "Pump ON" approx. 50 mm (2.5 in) below the inlet floor.
- ✓ Lower part of the level sensor is permanently immersed.

1. Insert the level sensor into the retaining pipe.
2. Adjust the switching points in the switchgear.

DrainLift	Pump ON*	Pump OFF	High water alarm*
WS 40 ...	0.4 m (16 in)	0.2 m (8 in)	0.45 m (18 in)
WS 50 ...	0.4 m (16 in)	0.2 m (8 in)	0.45 m (18 in)

* The values refer to an inlet floor of 450 mm (17.5 in). The value can be adjusted if the inlet is higher.

NOTICE! For increased operational reliability, install a separate float switch for high water detection! In order to prevent a backflow in the inlet pipe, set the high water alarm at the height of the inlet floor.

6.4.12 Lay the connection cable

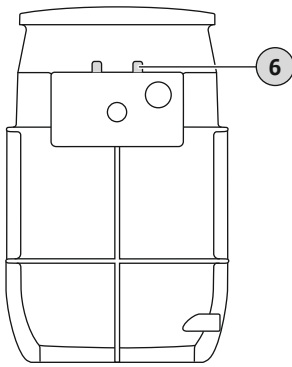

Fig. 16: Cable bushings

6.4.13 Fit the chamber cover

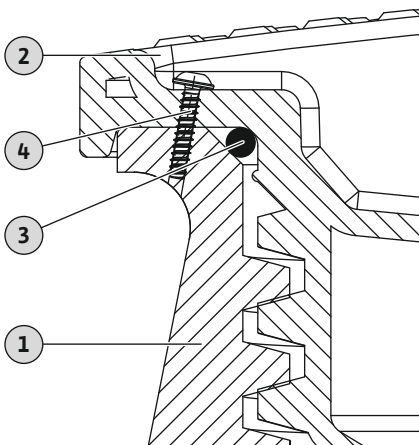

Fig. 17: Install and secure the chamber cover



WARNING

Risk of explosion due to escaping gases!

An explosive atmosphere can form within the pump chamber. If the explosive atmosphere spreads into the operating space, there is a risk of explosion!

- Seal all openings (cable entry, chamber cover etc.) airtight!
- Ensure regular air exchange in the operating space.
- Have a gas measurement carried out by an expert.

6

Cable bushings for installation in buildings:

- WS ... E: 1x M25 + 2x M16
- WS ... D: 2x M25 + 2x M16

- Route the connection cable to the outside via the cable bushings. Alternatively, the connection cables can also be routed to the outside via the connection for the cable pipe.
- Do not damage the connection cable (squeeze, bend etc.)!
- To prevent the connection cables from hanging individually in the pump chamber, tie the connection cables together with cable ties.
- Secure the connection cable on the chain hook for strain relief.
NOTICE! To be able to lift the pump out of the chamber (e.g. for maintenance), make sure that the connection cables are sufficiently long.
- Lay the connection cable according to the local regulations up to the switchgear or the socket.



WARNING

Risk of explosion due to escaping gases!

An explosive atmosphere can form within the pump chamber. If the explosive atmosphere spreads into the operating space, there is a risk of explosion!

- Seal all openings (cable entry, chamber cover etc.) airtight!
- Ensure regular air exchange in the operating space.
- Have a gas measurement carried out by an expert.

- The chamber cover can be secured against unauthorised opening.
- The chamber cover can be walked on.
The maximum load of the chamber cover is 200 kg (441 lb).

1	Pump chamber
2	Chamber cover
3	Gasket
4	Safety screw

- ✓ Pump chamber connected to the pipework.
- ✓ Connection cable led to the outside.
- ✓ Pump installation checked.

1. Push the gasket over the thread until it is in contact with the chamber cover in the curve.
2. Place the chamber cover onto the chamber opening and screw it in.
WARNING! If the chamber cover is screwed in, make sure that the gasket is fitted correctly. The gasket must not slip into the threads. If the gasket slips into a thread, it will be destroyed. The chamber cover is not sealed. Gases and pumped fluid can escape.
3. Drill a 3 mm hole at the intended location in the chamber cover. Drill a hole through the cover and the pump chamber.
4. Screw in the enclosed screw.

6.5 Installation – ground installation (under ground)

- ▶ Chamber cover fitted and secured.
- ▶ Make the electrical connection.



DANGER

Danger due to fluids hazardous to health during installation!

Danger of bacterial infection!

- Clean and disinfect installation location.
- Wipe up drips immediately.
- Observe the specifications of the factory regulations!
- If contact with fluids that are hazardous to health is possible, wear the following protective equipment:
 - sealed safety glasses
 - mouth protection
 - safety gloves



DANGER

Risk of fatal injury due to dangerous lone working practices!

Work in chambers and narrow rooms as well as work involving risk of falling are dangerous work. Such work may not be carried out autonomously!

- Only carry out work with another person!



WARNING

Suspended loads!

Danger of (serious) injuries caused by falling parts.

- Standing under suspended loads is prohibited!
- Do not move loads over workplaces where persons are present!

CAUTION

Buoyancy due to high ground water level!

Elevated groundwater can cause the pump chamber to float up.

- Observe information on the maximum permissible groundwater level.
-

CAUTION

Malfunction due to frost!

Frost can cause malfunctions and damage.

- Pay attention to local frost depths.
 - If the unit or discharge outlet are in the freezing zone, take the unit out of operation during freezing periods.
-



NOTICE

Installation of the pump chamber outside buildings

Observe EN 1610 and local regulations during ground installation!

- Wear protective equipment! Observe the work regulations.
 - Protective gloves: 4X42C (uvex C500 wet)
 - Safety shoes: Protection class S1 (uvex 1 sport S1)

- Safety helmet: EN 397 Conforms to standards, protection against lateral deformation (uvex pheos)
(When using lifting equipment)
- Pay attention to local frost depths.
- If toxic or asphyxiating gases accumulate, leave the workplace immediately!
- Install lifting equipment: even surface, clean, firm base. Warehouse and installation location must be easily accessible.
- Attach the chain or wire rope to the attachment points with a shackle. Only use lifting gear that has been technically approved.
- Do not stay within the swivel range of the hoisting gear.
- Provide threading strip for the installation of the connection cables.
- Installation of switchgear: Observe information in the manufacturer's instructions (IP class, overflow-proof, potentially explosive atmospheres)!

6.5.1 Work steps

The pump chamber is installed in the following steps:

- Preparatory tasks.
- Dig a pit and install pump chamber.
- Connect the pressure pipe. See building installation "Connecting the pressure pipe [▶ 15]"
- Connect the inlet. See building installation "Connect the inlet [▶ 16]"
- Connect the vent. See building installation "Connecting the vent [▶ 18]"
- Connect the cable pipe.
- Fit the pump chamber extension.
- Install the pump. See building installation "Install the pump [▶ 19]"
- Install the level control device. See building installation "Install the level control device [▶ 19]"
- Lay the connection cable.
- Backfill the pit.
- Fit the chamber cover. See building installation "Fit the chamber cover [▶ 21]"

6.5.2 Preparatory tasks

- Unpack the pump chamber.
- Remove the securing mechanisms.
- Check the scope of delivery.
- Select installation site:
 - Outside buildings.
 - Pay attention to local frost depths.
 - Not in the immediate vicinity of living and sleeping areas.
 - Do not install in peaty soil. **CAUTION! Peaty soil destroys the tank!**
 - Sufficient space available: Pit depth and diameter.
 - Ground water level
The pump chamber is anti-buoyant up to a max. ground water level of 500 mm (above the bottom edge of the chamber base).
- Keep accessories available for later use:
 - Chamber cover
 - Y-piece
The pump chambers WS 40 ... D and WS 50 ... D have separate pipework for each pump. They therefore also have two discharge ports.
NOTICE! Y-piece to be provided on-site!
 - Pump chamber extension (for height adjustment)
 - Switchgear
 - Level control



NOTICE

Ground installation (sub-surface installation): Comply with local regulations!

Civil engineering works are subject to strict local specifications. Observe the following points:

- Work may only be carried out by a trained specialist in underground and pipeline construction!
 - Dig, prepare and backfill the pit
 - Buoyancy safeguards
 - Connection of plastic pipes
- Observe local regulations for earthworks!
 - Slope angle
 - Pit lining ...
- Consider frost depths!

Install pump chamber so that it is anti-buoyant and does not twist. Dig out the pit, taking the following points into account:

- Min. pit depth: Chamber height + underlay + levelling layer + height of chamber cover
When using the chamber extension: Pit depth + 300 mm (12 in)
 - Min. pit diameter at the bottom: Chamber diameter + 2 m (6.5 ft)
 - Planned positions for inlet, pressure and venting line fit.
 - Pump out ground water.
Observe max. ground water level!
 - ✓ Preparatory tasks completed.
 - ✓ Pit dimensions specified.
 - ✓ Groundwater lowering system installed.
 - ✓ Filling material for underlay: load-bearing mineral mixture
 - ✓ Filling material for levelling layer and for backfilling: Sand/gravel, without sharp-edged components, non-cohesive, grain size 0 ... 32 mm)
1. Dig a pit.
 2. Professionally place and compact the underlay according to local specifications (Dpr 97 %).
 3. Professionally place the levelling layer according to the local specifications and level it.
 4. Insert the pump chamber into the pit.
 5. Align the pump chamber with the on-site piping.
 6. Vibrate the pump chamber evenly into the levelling layer.
NOTICE! Vibrate the chamber base and base ribs completely into the levelling layer!
 7. Check the position of the pump chamber and correct if necessary:
 - ⇒ Pump chamber should be vertical!
 - ⇒ Chamber cover flat to surface level!
 8. To fix the pump chamber, professionally backfill the pit in layers up to below the inlet areas. Comply with local regulations! Compress the individual layers properly (Dpr. 97 %).
 - ⇒ **NOTICE! Backfill and compact by hand at the pump chamber (blade, hand rammer)!**
 - ▶ Pump chamber installed.
 - ▶ Next step: Lay, prepare and connect on-site pipework to the pump chamber.

6.5.4 Connect the cable pipe

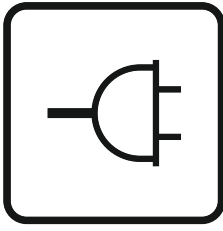
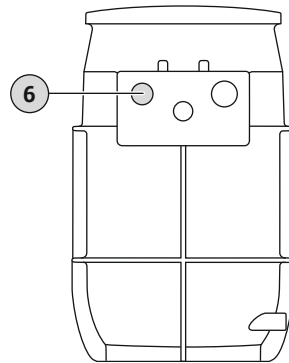

Fig. 18: Labelling on the pump chamber

The electrical connection cables are routed to the outside via a separate cable pipe. Observe the following points when connecting the cable pipe:

- Before connecting the cable pipe, pull in the threading strip.
- All connections must be completely tight.

DrainLift WS 40E/50E



DrainLift WS 40D/50D

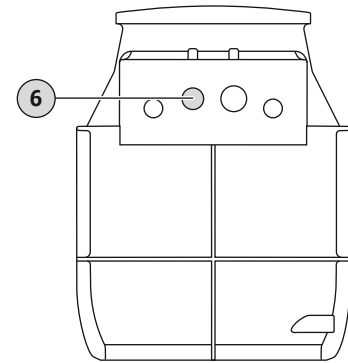

Fig. 19: Cable pipe connection

6	Cable pipe connection
---	-----------------------

- ✓ Pump chamber is installed properly.
 - ✓ On-site cable pipe is laid properly.
 - ✓ Retractable tape available in the on-site cable pipe.
 - ✓ HT sleeve socket available
1. Open the connection piece for the cable pipe: Sawing edge approx. 25 mm.
 2. Deburr and smooth the sawing edge.
 3. Put the HT sleeve socket on the connection port.
 4. Pull the retractable tape into the pump chamber.
 5. Insert the on-site cable pipe into the HT sleeve socket.
 - ▶ Cable pipe installed.
 - ▶ Next step: Install the pump chamber extension (if necessary).

6.5.5 Fit the pump chamber extension

The pump chamber extension can be used to compensate for a height difference of 300 mm (12 in) between the chamber opening and the surface edge.

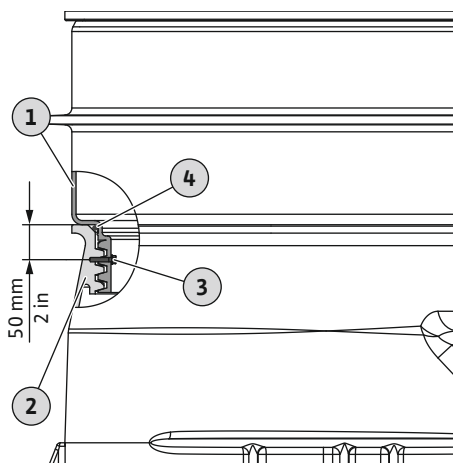

Fig. 20: Fit the pump chamber extension

1	Pump chamber extension
2	Pump chamber
3	Fastening screw
4	O-ring

- ✓ Height difference of 300 mm (12 in).
 - ✓ Pump chamber extension available.
 - ✓ Installation material included in the scope of delivery:
 - Fastening screw
 - Gasket (O-ring)
1. Push the gasket (O-ring) over the thread of the pump chamber extension up to the stop.
 2. Screw the pump chamber extension onto the pump chamber.
 3. Lock the pump chamber extension with the enclosed screw:
 - ⇒ Drill a 3 mm hole approx. 50 mm (2 in) from the top of the pump chamber.
 - ⇒ Screw in the enclosed wood screw as far as it will go.
 - ▶ Pump chamber extension installed.
 - ▶ Next step: Backfill the pit.

6.5.6 Lay the connection cable

- Attach the connection cable to the retractable tape and lead it through the cable pipe to the outside.
- Do not damage the connection cable (squeeze, bend etc.)!

6.5.7 Backfill the pit

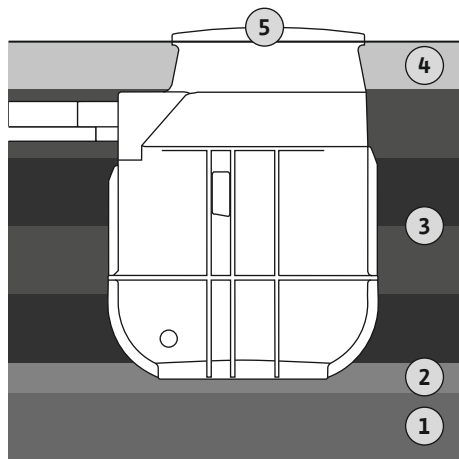

Fig. 21: Backfill the pit

- Do not leave the connection cable hanging individually in the pump chamber!
 - Tie the connection cable together with cable ties.
 - Secure the connection cable on the chain hook for strain relief.
 - **NOTICE! To be able to lift the pump out of the chamber (e.g. for maintenance), make sure that the connection cables are sufficiently long.**
- Lay the connection cable to the mains connection according to local specifications.

Observe the following points when backfilling the pit:

- Backfill the pit according to local specifications and guidelines!
- Make sure that the pump chamber is in a consistent and vertical position.
- Secure pump chamber against buoyancy. If necessary, fill the pump chamber with water.
- The details of the filling material are minimum requirements. Observe local guidelines.
- Carry out backfilling and compaction on the piping in accordance with local specifications and guidelines.

1	Underlay
2	Levelling layer
3	Compression layers
4	Substructure to the surface level
5	Chamber cover

- ✓ The pit is backfilled up to the inlet areas at the chamber.
 - ✓ Pump chamber is vertical.
 - ✓ All pipe adaptors are connected and sealed.
 - ✓ Pump chamber extension installed if necessary.
 - ✓ Filling material for backfilling: Sand/gravel, without sharp-edged components, non-cohesive, grain size 0 ... 32 mm)
1. Professionally backfill the pit and in layers at the same height up to the chamber neck. Comply with local regulations! Compress the individual layers properly (Dpr. 97 %).
 - ⇒ **NOTICE! Backfill and compress the pump chamber and pump chamber extension by hand (vane, hand rammer)!**
 2. Restore surface level with a substructure according to local regulations.
 - ⇒ **NOTICE! If the surrounding grown soil consists of cohesive material, the substructure can be made with this material. Max. grain size: 20 mm!**
 - ▶ The pit is backfilled.
 - ▶ Next step: Install the chamber cover.

6.6 Electrical connection



DANGER

Risk of fatal injury due to electrical current!

Improper conduct when carrying out electrical work can lead to death due to electric shock!

- Electrical work must be carried out by a qualified electrician!
- Observe local regulations!



NOTICE

Take note of additional literature!

To ensure proper use, additionally read and observe the manufacturer instructions.

- Earth the pump chamber in accordance with local regulations.
- Establish potential equalisation in accordance with local regulations.
- Carry out the electrical connection of the individual components according to the specifications in the respective installation and operating instructions.
- Install the mains connection and switchgear so that they are overflow-proof.

7 Commissioning

CAUTION

Damage in the pump chamber!

Coarse contaminants can cause damage to the pump chamber.

- Remove coarse contaminants from the pump chamber before commissioning.



NOTICE

Observe additional documentation

- Carry out the commissioning measures in accordance with the installation and operating instructions for the overall system.
- Observe the installation and operating instructions for the connected products (sensors and pumps) as well as the system documentation.

7.1 Personnel qualifications

- Operation/control: Operating personnel, instructed in the functioning of the complete system

7.2 Operator responsibilities

- Provide all installation and operating instructions at the pump chamber or at a designated place.
- Provide all installation and operating instructions in the personnel's language.
- Make sure that the installation and operating instructions have been read and understood by all personnel.
- All on-site safety devices are switched on and function properly.
- The pump chamber and the installed pump are suitable for use under the specified operating conditions.

7.3 Operation

Pump chamber with pump with fitted float switch

The individual pumps are directly controlled by the fitted float switch. After the plug has been inserted into the socket, the respective pump is now ready for operation and works in automatic mode.

It is recommended to equip the respective socket with an additional switch. This allows the system to be switched conveniently.

Pump chamber with pump, switchgear and separate level control

CAUTION

Malfunction due to incorrect operation of the switchgear!

When the plug is inserted, the switchgear starts in the last operating mode that was set.

- In order to be familiar with the operation of the switchgear, read the installation and operating instructions for the switchgear.

The unit is operated by the switchgear. For information on the operation of the switchgear and its individual displays, consult the installation and operating instructions for the switchgear.

7.4 Test run

Perform a test run before putting the pumping station into operation. A test run checks the proper functioning of the pumping station. If necessary, the switching points and the follow-up time of the pump must be adjusted.

- ✓ Pump chamber installed properly.
- 1. Remove the chamber cover.
- 2. Activate the unit:
 - ⇒ Unit **without** switchgear: Insert plug into socket.
 - ⇒ Unit **with** switchgear: Activate switchgear at the main switch. Select automatic mode.
- 3. Open the shut-off valve in the **discharge line**.

⇒ **NOTICE! The shut-off valve in the inlet remains closed!**

4. Fill the pump chamber with water via the chamber opening.
 - ⇒ **NOTICE! Do not hold water jet directly above the float switch!**
5. Pump is switched on and off using the level control.
 - ⇒ Carry out at least two complete pumping procedures of all pumps when conducting a test run.
 - ⇒ With double-pumping stations: The pump must be replaced after each pumping operation.
 - ⇒ Fill the pressure pipe completely with water to check the duty point. Repeat the test run until the pressure pipe is completely full.
6. **Building installation:** Check connections for impermeability.
 - ⇒ Only when all connections are tight may the pumping station be operated.
7. Fit the chamber cover and secure it against unauthorised opening.
 - ▶ Test run completed.
 - ▶ Pumping station **is put into operation:** Keep gate valve open in the **pressure pipe.**
 - ▶ Pumping station **remains in standby mode:** Close the gate valve in the **pressure pipe.**

7.5 Operation

The pumping station operates in automatic mode by default and is switched on and off using the integrated level control device.

- ✓ Commissioning has been carried out.
- ✓ Test run has been completed successfully.
- ✓ The operation and functioning of the pumping station are known.
- ✓ Pressure pipe completely filled with water.

1. Activate the pumping station:
 - ⇒ Unit **without** switchgear: Insert plug into socket.
 - ⇒ Unit **with** switchgear: Activate switchgear at the main switch. Select automatic mode.
2. Open the gate valve in the inlet and pressure pipe.
 - ▶ The pumping station operates in automatic mode and the pump is controlled depending on the level.

7.6 During operation

- Open the gate valve in the inlet and discharge line!
- The maximum inflow is less than the maximum output of the unit.
- Do not remove the chamber cover!
- Ensure venting of the pump chamber!
- If the outside temperature remains below 0 °C for a prolonged period of time, there is a risk of frost in the pump chamber if the water exchange is insufficient:
 - Provide insulation measures above the chamber cover.
 - Decommission the pump chamber.

8 Shut-down/dismantling

8.1 Personnel qualifications

- Electrical work: qualified electrician
Person with appropriate technical training, knowledge and experience who can identify and prevent electrical hazards.
- Installation/dismantling work: trained specialist in plant technology for sanitary facilities
Fixation and buoyancy safeguards, connection of plastic pipes
- Ground installation (underground): trained specialist in underground and pipeline construction
Excavate and prepare the pit, backfill the pit, buoyancy safeguards, connection of plastic pipes.
- Lifting work: trained specialist for the operation of lifting devices
Lifting equipment, lifting gear, attachment points

8.2 Operator responsibilities

- Observe locally applicable accident prevention and safety regulations of professional and trade associations.

- Provide the necessary protective equipment and make sure that the personnel wears it.
- Ensure enclosed spaces have sufficient ventilation.
- Take immediate countermeasures if there is a build-up of toxic or suffocating gases!
- When working in enclosed spaces, a second person must be present for safety reasons.
- When using lifting equipment, observe all regulations for working with and under suspended loads!

8.3 Shut-down

1. Close the gate valve in the inlet pipe.
2. Switch the switchgear to standby mode.
3. Drain the pump chamber.
Activate the pump in manual mode and drain the pump chamber.
4. Close the gate valve in the pressure pipe.
5. Pump out the remaining pumped fluid via emergency draining.
6. Switch off the pumping station:
 - ⇒ Unit **without** switchgear: Pull the plug out of the socket.
 - ⇒ Unit **with** switchgear: Switch off switchgear at the main switch.
 - ⇒ **NOTICE! Secure the unit against unauthorised reactivation!**
 - ▶ Pumping station decommissioned.

If the pumping station is out of operation for an extended period, carry out a “test run” check at regular intervals (quarterly).

8.4 Clean and disinfect

- Wear protective equipment! Observe the work regulations.
 - Safety shoes: Protection class S1 (uvex 1 sport S1)
 - Breathing protection: Half mask 3M series 6000 with filter 6055 A2
 - Protective gloves: 4X42C + Type A (uvex protector chemical NK2725B)
 - Safety goggles: uvex skyguard NT
 - Use of disinfectants:
 - Use strictly according to the manufacturer’s instructions!
 - Wear protective equipment according to the manufacturer’s instructions!
 - Dispose of rinsing water in accordance with the local regulations, e.g. feed it into the sewer!
 - ✓ Pumping station decommissioned.
1. Remove the chamber cover.
 2. Activate the unit:
 - ⇒ Unit **without** switchgear: Insert plug into socket.
 - ⇒ Unit **with** switchgear: Activate switchgear at the main switch.
 3. Open the gate valve in the pressure pipe.
 4. Spray the pump chamber from the inside via the chamber opening using clean water from top to bottom.
 5. Disinfect the pumping station.
 6. Drain the pump chamber.
 - ⇒ Unit **with** switchgear: Activate the pump in manual mode and drain the pump chamber.
 7. Repeat steps 4 to 6 until the pump chamber, pump and level control device are cleaned.
 8. Close the gate valve in the pressure pipe.
 9. Pump out the remaining pumped fluid via emergency draining.
 10. Decommission the pumping station.
 11. Allow the pumping station to dry out.
 12. Fit the chamber cover.
 - ▶ Pumping station disinfected. The individual components can now be removed.

8.5 Pump removal

**DANGER****Danger due to fluids which are hazardous to health!**

Danger of bacterial infection!

- Disinfect the pump after removal!
- Observe the specifications of the work regulations!

**DANGER****Risk of fatal injury due to electrical current!**

Improper conduct when carrying out electrical work can lead to death due to electric shock!

- Electrical work must be carried out by a qualified electrician!
- Observe local regulations!

**DANGER****Risk of fatal injury due to dangerous lone working practices!**

Work in chambers and narrow rooms as well as work involving risk of falling are dangerous work. Such work may not be carried out autonomously!

- Only carry out work with another person!

Wear the following protective equipment while performing the work:

- Safety shoes: Protection class S1 (uvex 1 sport S1)
- Protective gloves: 4X42C (uvex C500 wet)
- Safety helmet: EN 397 Conforms to standards, protection against lateral deformation (uvex pheos)
(When using lifting equipment)

If contact with hazardous fluid occurs during work, wear the following additional protective equipment:

- Safety goggles: uvex skyguard NT
 - Labelling frame: W 166 34 F CE
 - Labelling disc: 0-0.0* W1 FKN CE
- Breathing protection: Half mask 3M series 6000 with filter 6055 A2

The protective equipment specified is the minimum requirement. Observe the specifications of the work regulations!

* Protection level according to EN 170 not relevant for this work.

The pump can be removed from the pump chamber for maintenance work on the pump.

- ✓ Pumping station decommissioned.
 - ✓ Pumping station incl. all components disinfected.
 - ✓ Protective equipment used.
 - ✓ Working area cordoned off.
1. Remove the chamber cover.
 2. Attach the hoisting chain to the lifting accessory.
 3. Uncouple the pump with discharge line at the surface coupling.
 4. Remove the pump.
 - ⇒ **NOTICE! Attach a drawing wire to the connection cable of the pump. Pull the drawing wire into the chamber when removing the pump.**
 5. Fit the chamber cover.
 - ▶ Pump removed.

9	Maintenance and repair	<p>Pump chamber</p> <ul style="list-style-type: none"> • Chamber cover gasket Replace every time the chamber cover is removed. • Surface coupling Check the pumps are working correctly each time they are removed. <p>Pump</p> <ul style="list-style-type: none"> • Carry out maintenance work according to the manufacturer's instructions in the installation and operating instructions. <p>Switchgear</p> <ul style="list-style-type: none"> • Carry out maintenance work according to the manufacturer's instructions in the installation and operating instructions. <p>Level control</p> <ul style="list-style-type: none"> • Carry out maintenance work according to the manufacturer's instructions in the installation and operating instructions.
10	Spare parts	Spare parts are ordered via customer service. To avoid return queries and incorrect orders, the serial or article number must always be supplied. Subject to change without prior notice!
11	Faults, causes and remedies	If faults occur, observe the installation and operating instructions of the individual components.
12	Disposal	
12.1	Protective clothing	Used protective clothing must be disposed off in accordance with the locally applicable guidelines.









wilo



Local contact at
www.wilo.com/contact

Pioneering for You

WILO SE
Wilopark 1
44263 Dortmund
Germany
T +49 (0)231 4102-0
T +49 (0)231 4102-7363
wilo@wilo.com
www.wilo.com