

Data Sheet | Item Number: 713-1415/117-000/997-409

THR male header, 2-row; 0.8 x 0.8 mm solder pin; straight; 100% protected against mismatching; in tape-and-reel packaging; Pin spacing 3.5 mm; 30-pole; black

<https://www.wago.com/713-1415/117-000/997-409>



Color: ■ black

Similar to illustration

Similar to illustration

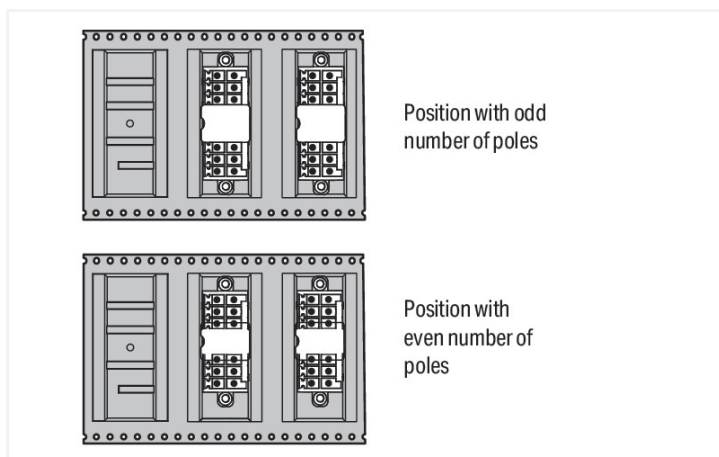
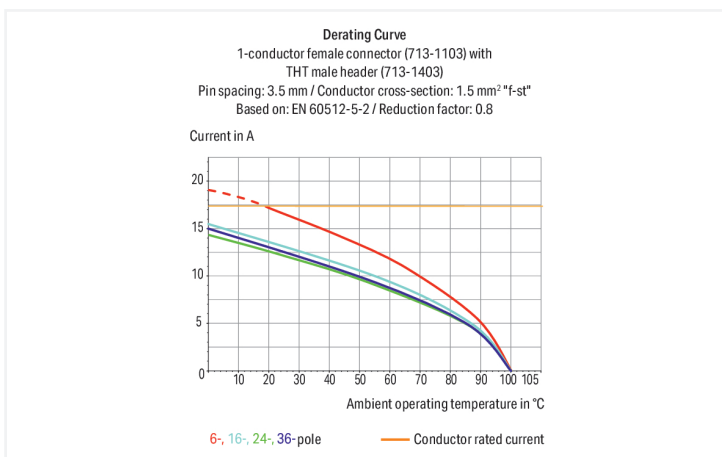

Dimensions in mm
 Pin position in tape-and-reel packaging

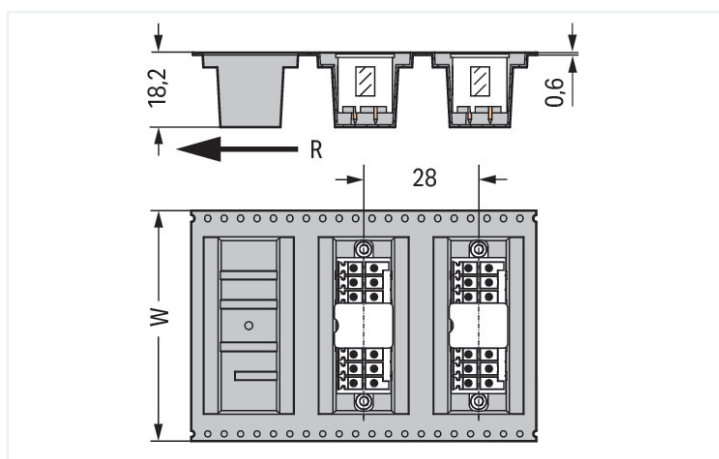
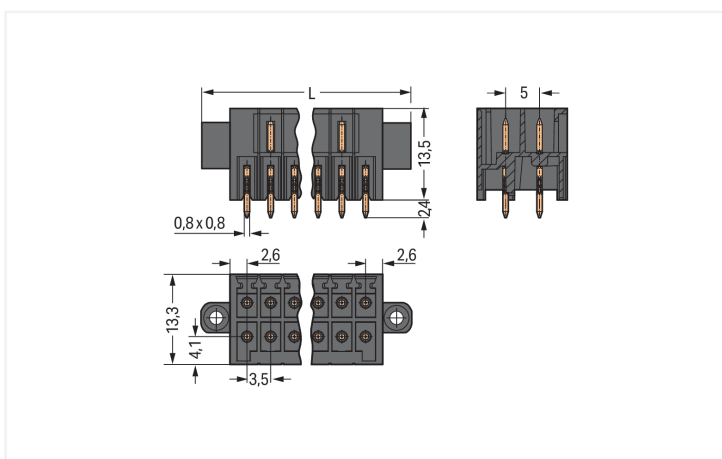

Male connector, 713 Series, black

This male connector (item number 713-1415/117-000/997-409) is designed for fault-free electrical installations. The dimensions are (62.6 x 15.9 x 13.3) mm (width x height x depth).

The contact surface is coated with tin. The pcb connector is designed for THR soldering.

Notes	
Safety Information	The MCS – MULTI CONNECTION SYSTEM includes connectors without breaking capacity in accordance with DIN EN 61984. When used as intended, these connectors must not be connected/disconnected when live or under load. When used as intended, these connectors must not be connected/disconnected when live or under load. The circuit design should ensure header pins, which can be touched, are not live when unmated.
Variants:	Other pole numbers Other solder pin lengths Gold-plated or partially gold-plated contact surfaces Other versions (or variants) can be requested from WAGO Sales or configured at https://configurator.wago.com/ .

Electrical data

Ratings per	IEC/EN 60664-1			Approvals per	UL 1059		
Overvoltage category	III	III	II	Use group	B	C	D
Pollution degree	3	2	2	Rated voltage	150 V	50 V	-
Nominal voltage	80 V	160 V	250 V	Rated current	10 A	10 A	-
Rated impulse withstand voltage	2.5 kV	2.5 kV	2.5 kV				
Rated current	10 A	10 A	10 A				

Approvals per	CSA		
Use group	B	C	D
Rated voltage	150 V	-	-
Rated current	12 A	-	-

Connection Data

Total number of potentials	30	Connection 1	
Number of connection types	1	Pole number	30
Number of levels	2		

Physical data

Pin spacing	3.5 mm / 0.138 inches
Width	62.6 mm / 2.465 inches
Height	15.9 mm / 0.626 inches
Height from the surface	13.5 mm / 0.531 inches
Depth	13.3 mm / 0.524 inches
Solder pin length	2.4 mm
Solder pin dimensions	0.8 x 0.8 mm
Plated through-hole diameter (THR)	1.3 (+0.1) mm
Reel diameter of tape-and-reel packaging	330 mm
Tape width	88 mm

Mechanical data

Variable coding	Yes
Anti-rotation protection	Yes

Plug-in connection

Contact type (pluggable connector)	Male connector/plug
Connector (connection type)	for PCB
Mismating protection	Yes
Mating direction to the PCB	90 °
Locking of plug-in connection	Threaded flange

PCB contact

PCB contact	THR
Solder pin arrangement	over the entire male connector (in-line)
Number of solder pins per potential	1

Material data

Note (material data)	Information on material specifications can be found here
Color	black
Material group	I
Insulation material (main housing)	Polyphthalamide (PPA GF)
Flammability class per UL94	V0
Contact material	Electrolytic copper (E _{Cu})
Contact Plating	Tin
Fire load	0 MJ
Weight	8.1 g
MSL per J-STD 020D	1

Environmental requirements

Limit temperature range	-60 ... +100 °C
Processing temperature	-35 ... +60 °C

Environmental Testing

Test specification: Railway applications – Rolling stock – Electronic equipment	DIN EN 50155 (VDE 0115-200):2022-06
Test procedure: Railway applications – Rolling stock equipment – Vibration and shock tests	DIN EN 61373 (VDE 0115-0106):2011-04
Spectrum/Mounting location	Service life test, Category 1, Class A/B
Functional test with noise-like oscillations	Test passed according to Section 8 of the standard
Frequency	f ₁ = 5 Hz to f ₂ = 150 Hz
Acceleration	0.101g (highest test level used for all axes)
Test duration per axis	10 min.
Test directions	X, Y and Z axes
Monitoring of contact faults and interruptions	Passed
Voltage drop measurement before and after each axis	Passed
Simulated service life test through increased levels of noise-like oscillations	Test passed according to Section 9 of the standard
Frequency	f ₁ = 5 Hz to f ₂ = 150 Hz
Acceleration	0.572g (highest test level used for all axes)
Test duration per axis	5 h

Environmental Testing

Test directions	X, Y and Z axes
Extended testing: Monitoring of contact faults and interruptions	Passed
Extended testing: Voltage drop measurement before and after each axis	Passed
Shock test	Test passed according to Section 10 of the standard
Shock pulse form	Half sine
Acceleration	5g (highest test level used for all axes)
Shock duration	30 ms
Number of shocks (per axis)	3 pos. und 3 neg.
Test directions	X, Y and Z axes
Extended testing: Monitoring of contact faults and interruptions	Passed
Extended testing: Voltage drop measurement before and after each axis	Passed
Vibration and shock stress for rolling stock equipment	Passed

Commercial data

PU (SPU)	120 pcs
Packaging type	Bag
Country of origin	DE
GTIN	4050821308935
Customs tariff number	85366930000

Product Classification

UNSPSC	39121409
eCl@ss 10.0	27-44-04-02
eCl@ss 9.0	27-44-04-02
ETIM 9.0	EC002637
ETIM 10.0	EC002637
ECCN	NO US CLASSIFICATION

Environmental Product Compliance

RoHS Compliance Status	Compliant,With Exemption
RoHS Exemption	6(c)
SCIP notification number (Austria)	1b6e920c-00b4-48d6-a20a-f82a76a805d8
SCIP notification number (Belgium)	bbae1a5b-1de2-4918-ae52-0e51c0390d0e
SCIP notification number (Bulgaria)	0563fb83-26d1-4547-b996-669af98ca1c6
SCIP notification number (Czech Republic)	dbd18eac-2454-4dac-a99c-2288d0dbabc5
SCIP notification number (Denmark)	7dad3867-58cf-403c-a655-90b98eb059d8
SCIP notification number (Finland)	b7639f97-532f-47e5-a49b-19a319ae3008
SCIP notification number (France)	9facc453-f8a9-478f-a738-fcf1b122b8bd
SCIP notification number (Germany)	968768f9-0671-49a7-8077-cb65bb389c34
SCIP notification number (Hungary)	1637d858-201d-4fe6-9300-7f4d5c0f3f2c
SCIP notification number (Italy)	a243aeb7-e0f5-4793-9907-92fa1935fbc6
SCIP notification number (Netherlands)	0fb72d69-5884-4dcf-93e3-ed8dd2a538c5
SCIP notification number (Poland)	e5772fac-ff62-4abc-b51a-1fc75904498e
SCIP notification number (Romania)	d6c3d716-db79-4e13-b383-faa9bf1828c4
SCIP notification number (Sweden)	6976cae3-97c2-4092-acc7-4e6e9631e050

Approvals / Certificates

General approvals



Approval	Standard	Certificate Name
CB DEKRA Certification B.V.	IEC 61984	NL-102427
CSA CSA Group	C22.2	2315087
KEMA/KEUR DEKRA Certification B.V.	EN 61984	71-126089

Declarations of conformity and manufacturer's declarations



Approval	Standard	Certificate Name
Railway WAGO GmbH & Co. KG	-	Z00004424.000

Downloads

Environmental Product Compliance

Compliance Search
↓

Documentation

Additional Information			
Technical Section	03.04.2019	pdf 2027.26 KB	↓
		pdf 535.32 KB	↓

CAD/CAE-Data

CAD data
↓

PCB Design
↓
↓

1 Compatible Products

1.1 System counterpart

1.1.1 Female connector/socket



Item No.: 713-1115/107-000

1-conductor female connector, 2-row; CA-GE CLAMP®; 1.5 mm²; Pin spacing 3.5 mm; 30-pole; 100% protected against mismatching; Screw flange; black

1.2 Optional Accessories

1.2.1 Coding

1.2.1.1 Coding



Item No.: [714-101](#)
Coding key; orange

Installation Notes

Coding

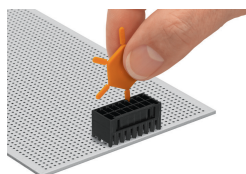

Coding a male header by inserting a coding pin.