

# Pressure reducing valves



## 539 series

01188/17 GB

replaces dp 01188/10 GB



### Function

Pressure reducing valves are installed in residential plumbing systems to reduce and stabilise inlet pressure from the water mains supply which is generally too high and variable for domestic systems to function properly.

Conforms to standards NF 079 doc.4 - EN 1567.



### Product range

Code 539250 Pressure reducing valve \_\_\_\_\_ size 3/4" F

### Technical specifications

#### Materials

Body: dezincification resistant alloy **CR** CB752S  
 Nipples: dezincification resistant alloy **CR** CW602N  
 Cover: PA66G38  
 Obturator: dezincification resistant alloy **CR** CW602N  
 Moving parts: dezincification resistant alloy **CR** CB752S  
 Spring: steel EN 10270-1 DH (C98)  
 Seat: stainless steel AISI 303  
 Diaphragm: NBR  
 Hydraulic seals: NBR

#### Performance

Medium: water  
 Max. upstream pressure: 25 bar  
 Downstream pressure setting range: 1-5,5 bar  
 Factory setting: 3 bar  
 Max. working temperature: 80°C

#### Connections:

- Main connections: please refer to the dimensions table
- Double pressure gauge connection: 1/4" F (ISO 228-1)

### Dimensions

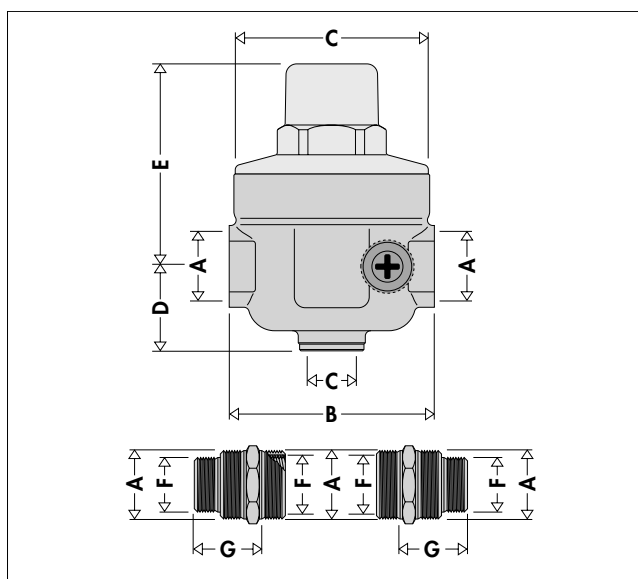

Code	A	B	C	D	E	F	G	Mass (kg)
539250	3/4"	77	75	31,5	75,5	1/2"	25,5	0,880

## Section

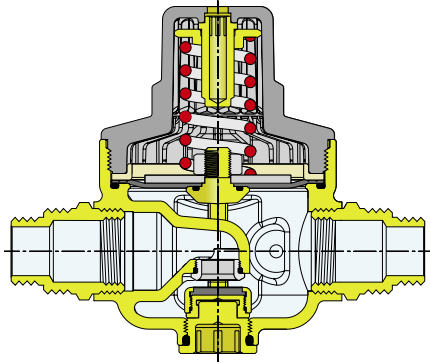

## Hydraulic characteristics

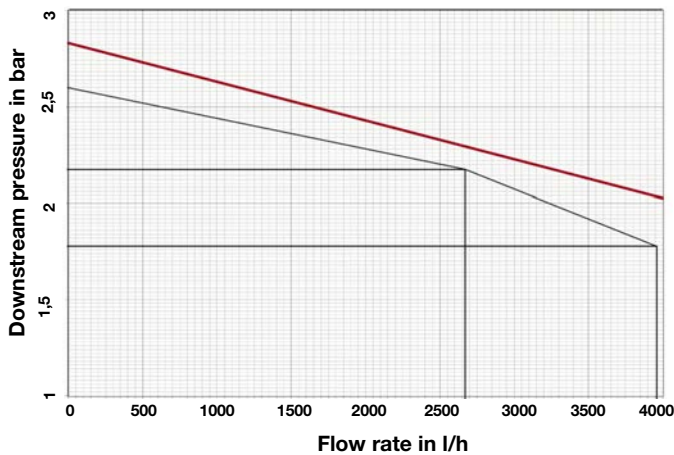

The black curve meets the requirements of standard NF. The red curve represents the progress of the downstream pressure, as the flow rate varies.

## Installation

1. Turn all the taps on before installing the pressure reducing valve, to flush the system and expel any air remaining in the pipes.
2. Install the shut-off valves upstream and downstream to facilitate maintenance procedures.
3. The pressure reducing valve may be installed with either vertical or horizontal pipes. However, it must not be installed upside down.

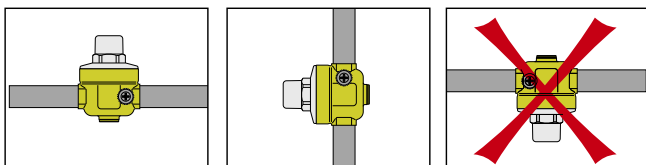

4. Close the downstream shut-off valve.
5. Calibrate it by turning the screw on top of the plastic casing using a 5 mm hexagonal key. Clockwise to increase the pressure setting and anticlockwise to decrease it.
6. Read the desired value off the pressure gauge. 539 series pressure reducing valves are factory set to 3 bar.

## Installation recommendations

### Cavitation diagram

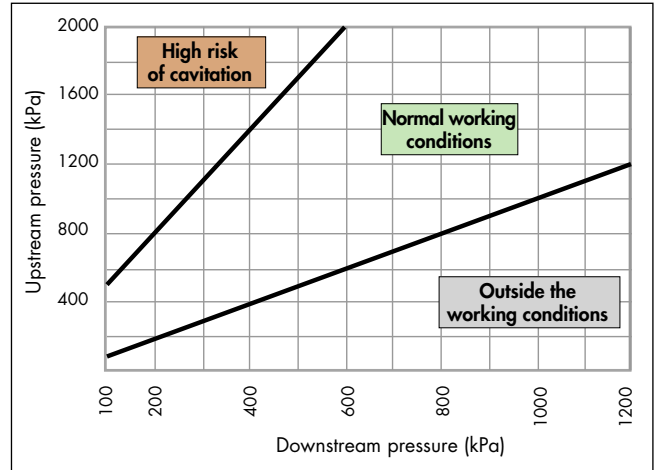

In order to minimise the risk of cavitation inside the reducing valve, which could cause malfunctioning with the risk of erosion in the region of the seal, vibration and noise, it is strongly recommended that you refer to the working conditions specified in the diagram. Owing to multiple factors and variable conditions that have been experimented, such as: system pressure, temperature, presence of air, flow rate and speed, which could affect the behaviour of the reducing valve; it is advisable for the ratio between the upstream pressure and the downstream pressure to be kept ideally within a value of 2:1 and not in excess of 3:1 (for instance, upstream pressure 10 bar, downstream pressure 5 bar, pressure ratio =  $10/5 = 2:1$ ). In such conditions, the risk of possible cavitation is reduced to a minimum, nevertheless this does not completely exclude the possible effects due to the other numerous factors present inside the system during operation. If the pressure ratio exceeds the limit specified, the design pressure of the system or the use of a first-stage reducing valve should be considered (for instance, first-stage pressure reducing valve from 16 to 8 bar and then second stage from 8 to 4 bar). The piping upstream and downstream of the pressure reducing valve must be bracketed according to the manufacturer's instructions, local specifications, in order to avoid creating and transmitting vibrations and/or noise in the installation.

### Installation below ground

Installing pressure reducing valves below ground is not recommended, for four reasons:

- there is a risk of the reducing valve being damaged by frost
- inspection and maintenance operations are difficult
- reading the pressure gauge is difficult
- impurities may enter the device through the holes designed for the release of the volumetric compression present in the casing.

### Water hammer

This is one of the main causes of faults in pressure reducing valves. It is best to fit special devices to absorb water hammer when installing pressure reducers in at-risk systems.



Sizing software is available on  
[www.caleffi.com](http://www.caleffi.com),  
 Apple Store and Google play.

## SPECIFICATION SUMMARY

### Code 539250

Pressure reducing valves. Threaded connections 3/4" F. Dezincification resistant alloy body and obturator. Brass moving parts. Stainless steel seat. Steel spring. NBR diaphragm. NBR hydraulic seals. Medium: water. Maximum working temperature: 80°C. Maximum upstream pressure: 25 bar. Downstream pressure setting range: 1–5,5 bar. Factory setting: 3 bar. Double pressure gauge connection. Fitted with two female-male fittings.

We reserve the right to make changes and improvements to the products and related data in this publication, at any time and without prior notice.