

# Productinformatieblad

Specificaties



## System M - WCD - Dubbele USB-poort - 2.4A 16A - Antraciet

MEG2366-0414

EAN Code: 4042811217631

**Prijs: 124,60 EUR**

### Hoofd

|                           |                                    |
|---------------------------|------------------------------------|
| range                     | Merten                             |
| product name              | System m-inzetstukken              |
| product or component type | USB-lader + wandcontactdoosuitgang |

### Complementair

|                                       |   |
|---------------------------------------|---|
| product presentatie                   | Mechanisme met bevestigingsframe en afdekplaat  |
| montage apparaat                      | Verzonken   |
| nummerstekkerbus                      | 1   |
| configuratie polen stopcontact        | 2P + E  |
| standaard stopcontact                 | Schuko  |
| afdekkingstype                        | Met rolluik   |
| nominale stroom                       | 16 A  |
| Type USB-voeding                      | USB type A + A  |
| geïntegreerd aansluitingstype         | 1 wandcontactdoosuitgang 250 V AC, maximale belastingsstroom: 16 A<br>2 USB-poort 5 V DC, maximale belastingsstroom: 2,4 A  |
| input vermogen                        | 12 W  |
| montagesteun                          | CEE60 inbouwdoos  |
| positie geaarde kabelschoen           | Rechte 0° positie   |
| bevestigingsmethode                   | Met schroeven en klauwen  |
| kleurtint                             | Antraciet (RAL 7024)  |
| oppervlakte afwerking                 | Mat   |
| oppervlaktebehandeling                | Geverfd   |
| type of packing                       | Doos  |
| ambient air temperature for storage   | -20...60 °C   |
| type bescherming                      | Automatische herstart na aardlek of stroomuitval<br>Acculaadbescherming<br>Thermische beveiliging<br>1 externe zekering<br>Tegen kortsluitingen<br>Automatische overbelastingsbeveiliging |
| ambient air temperature for operation | -5...35 °C  |
| levensduur in cycli                   | 30000 cycles  |
| connections - terminals               | Schroefloze aansluitklemmen   |
| aantal aansluitklemmen                | 3   |

De weergegeven prijs is de adviesprijs in euro excl. BTW. Deze kan onderhevig zijn aan korting. Neem contact op met uw lokale distributeur of detailhandel voor de daadwerkelijke prijs

|                            |  |
|----------------------------|--|
| number of cables           | 2  |
| capaciteit klemaansluiting | 1.5...2.5 mm <sup>2</sup> voor stijf kabel(s)<br>1.5...2.5 mm <sup>2</sup> voor gestrengd kabel(s) |
| materiaal                  | Thermoplast<br>PC (polycarbonaat): behuizing   |
| wire stripping length      | 11 mm  |
| height                     | 71 mm  |
| width                      | 71 mm  |
| depth                      | 44 mm  |
| inbouwdiepte               | 32 mm  |
| net weight                 | 0,092 kg   |
| standards                  | IEC 60884-1<br>NEN-EN 50198-2<br>EN/IEC 60950<br>DIN VDE 0620-1                                    |
| product certifications     | VDE<br>CB<br>KEMA-KEUR<br>NEMKO<br>SEMKO<br>FIMKO  |
| IK-beschermingsgraad       | IK04   |
| IP-beschermingsgraad       | IP20   |

## Omgeving

|                      |                                   |
|----------------------|-----------------------------------|
| milieu-eigenschappen | Binnengebruik<br>Normale omgeving |
|----------------------|-----------------------------------|

## Verpakkingseenheid

|                              |           |
|------------------------------|-----------|
| Unit Type of Package 1       | PCE       |
| Number of Units in Package 1 | 1         |
| Package 1 Height             | 6,700 cm  |
| Package 1 Width              | 7,600 cm  |
| Package 1 Length             | 7,800 cm  |
| Package 1 Weight             | 116,000 g |
| Unit Type of Package 2       | CAR       |
| Number of Units in Package 2 | 80        |
| Package 2 Height             | 31,000 cm |
| Package 2 Width              | 33,600 cm |
| Package 2 Length             | 40,900 cm |
| Package 2 Weight             | 9,776 kg  |

## Environmental Data

Schneider Electric wil tegen 2050 de Net Zero-status hebben bereikt via partnerschappen in de toeleveringsketen, materialen met een lagere impact en circulariteit via onze doorlopende campagne "Use Better, Use Longer, Use Again" om de levensduur van producten en de recycleerbaarheid te verlengen.

[Uitleg van Environmental Data](#) >

[Hoe evalueren we de duurzaamheid van producten?](#) >

### Use Better

|  <b>Materialen en verpakking</b> |                                      |
|---|--------------------------------------|
| Pakket met gerecycleerd karton  | Nee                                  |
| Verpakkingen zonder kunststof   | Nee                                  |
| EU-richtlijn RoHS   | Voldoet niet                         |
| SCIP-nummer   | 877db2a3-bca0-49d1-8140-447880b153d6 |
| REACH-regelgeving   | <a href="#">REACH-verklaring</a>     |

### Use Again

|  <b>Herverpakken en herfabriceren</b> |   |
|---|---|
| Terugname   | No  |
| WEEE Label  |  Het product moet op markten van de Europese Unie worden afgevoerd volgens specifieke afvalinzamelingsregels en mag nooit in een gewone vuilnisbak terechtkomen. |

## Technical Illustration

### Wiring diagram

---

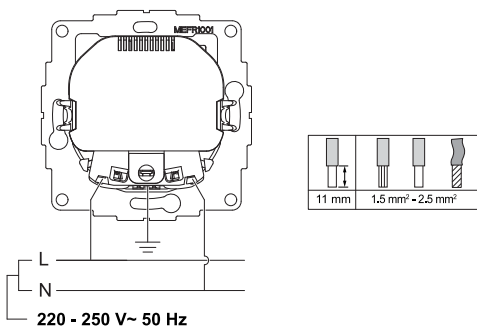

#### **⚠ ⚠ DANGER**

##### **HAZARD OF ELECTRIC SHOCK, EXPLOSION OR ARC FLASH**

The product must be installed and connected by a qualified electrician.

A qualified electrician must demonstrate an in-depth knowledge of:

- Construction of electrical installations in buildings in accordance with IEC 60364
- Additional safety standards, local connection rules, and building regulations
- Standardized tools and measuring equipment

**Failure to follow these instructions will result in death or serious injury.**

Image of product / Alternate images

Alternative

---

