

Anti-thermosiphon check valve



510 series



01045/10 GB



Function

The anti-thermosiphon check valve prevents the natural circulation of water in systems where ambient temperature adjustment is carried out by a thermostat connected to the pump.

The anti-thermosiphon check valve allows water to reach the heat emitters only when the pump is running: when the pump is not running, the check valve is activated and the system remains separate from the heat generator.

The check valve function can be overridden using the corresponding knob and the valve can be used with straight or angled connections by moving the relevant cap.

Product range

510 series Anti-thermosiphon check valve

sizes 3/4"-1 1/4"

Technical specifications

Materials

Body:	brass EN 12165 CW617N
Check valve:	PSU
Check valve spring:	stainless steel
Check valve seal:	EPDM
Cap seal:	EPDM
Control knob:	ABS
Control knob seal:	PTFE
Control stem seals:	EPDM

Performance

Medium:	water, glycol solutions
Max. percentage of glycol:	30%
Max. working pressure:	10 bar
Min. opening pressure for check valve:	0,02 bar
Working temperature range:	5-110°C
Connections:	3/4"-1 1/4" F

Dimensions

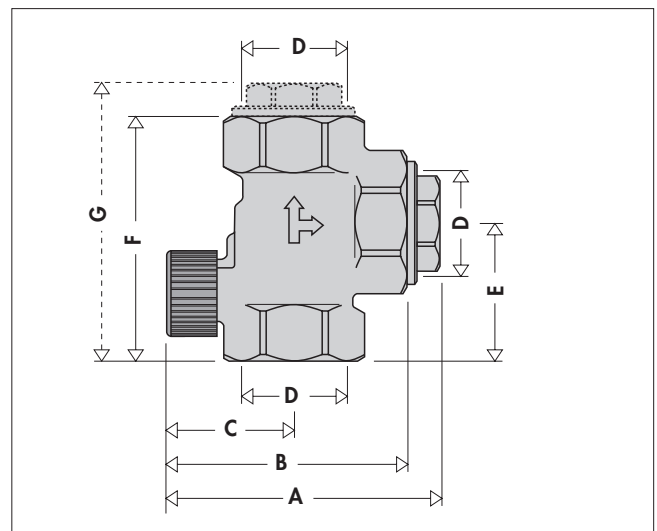

Code	D	A	B	C	E	F	G	Mass (kg)
510500	3/4"	87	77	43	45	82	92	0,65
510600	1"	87	77	43	45	82	92	0,53
510700	1 1/4"	103	91	48	52	93	105	0,82

Operating principle

The anti-thermosiphon check valve body houses a special hydraulically-shaped check obturator (1). During normal circulation of the medium (while the pump is running), the obturator is pushed against the counter-acting spring inside it, so as to open the channel to allow the medium to flow through. When the pump stops running and the flow of medium stops, the obturator is pushed in the opposite direction, against the seal seat (2), in order to prevent medium backflow. In this way, the obturator completely shuts off the flow of medium through the special contoured seal (3). Knob (4) can be used to deactivate obturator intervention, by turning the control stem (5) by 180° to keep the channel always open.

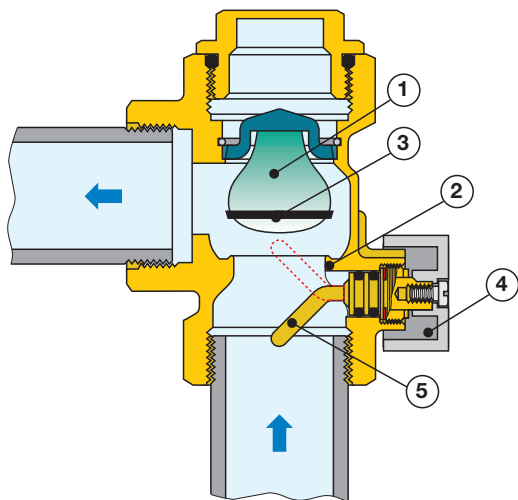

Knob positions

In "normal" position, the valve is in its operating condition, with the check valve active and an opening pressure of 0,02 bar.

In "open" position, the valve overrides its check function.

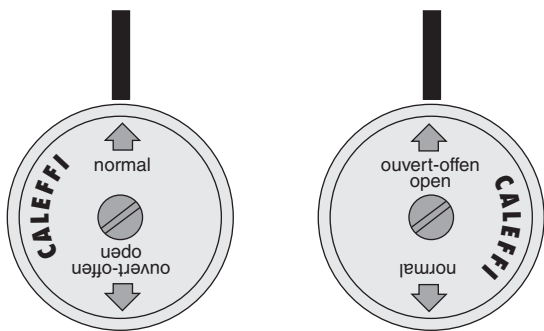

Construction details

Silent operation

Thanks to the ogival hydraulic shape of the obturator, the anti-thermosiphon check valve guarantees silent operation.

Quick operation

The seal positioned on the obturator and the counter-acting spring located inside the obturator ensure there are no delays in closure and guarantee an watertight seal, even when slight back pressure is applied.

Non-sensitivity to impurities

The sliding parts, thanks to a special coupling, are not sensitive to the small impurities in the water, or to the deposits which can form as a result of prolonged periods of inactivity.

Hydraulic characteristics

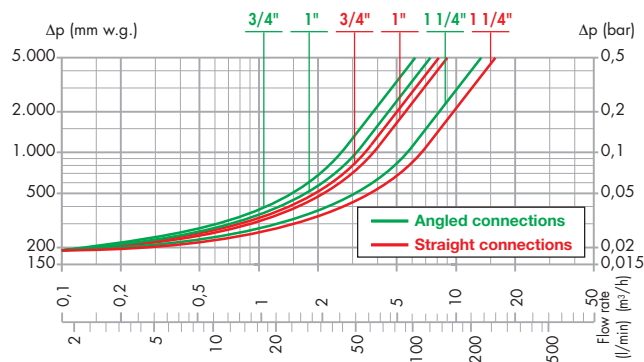

Installation

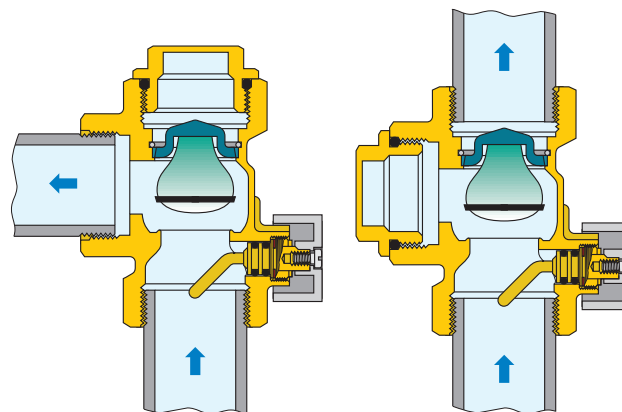

The valve should be installed in accordance with the flow direction indicated by the arrow on the valve body. The valve can be used with straight or angled connections, by moving the third way sealing cap. The valve should be installed with the check valve axis vertically, in accordance with one of the two diagrams provided.

SPECIFICATION SUMMARY

510 series

Anti-thermosiphon check valve. Threaded connections 3/4" F (from 3/4" to 1 1/4"). Brass body. PSU check valve. Stainless steel spring. EPDM seals. PTFE control knob seal. ABS control knob. Medium water, glycol solutions. Maximum percentage of glycol 30%. Working temperature range 5-110°C. Maximum working pressure 10 bar. Minimum opening pressure for check valve 0,02 bar. Angled or straight layout depending on cap position. Check valve override option.

We reserve the right to change our products and their relevant technical data, contained in this publication, at any time and without prior notice.



CALEFFI S.p.A. · S.R.229, N.25 · 28010 Fontaneto d'Agogna (NO) · Italy · Tel. +39 0322 8491 · Fax +39 0322 863723 · www.caleffi.com · info@caleffi.com ·