

Data Sheet | Item Number: 280-613/281-411

Component terminal block; 2-conductor; with diode 1N4007; anode, right side; for DIN-rail 35 x 15 and 35 x 7.5; 2.5 mm²; CAGE CLAMP®; 2,50 mm²; gray

<https://www.wago.com/280-613/281-411>

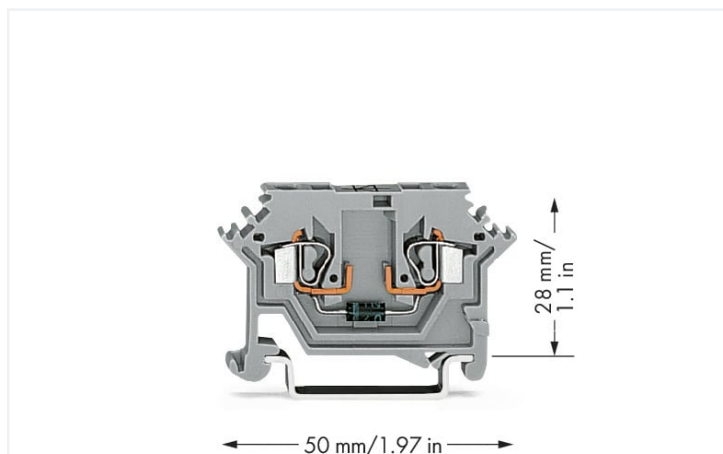

Color: ■ gray

Similar to illustration

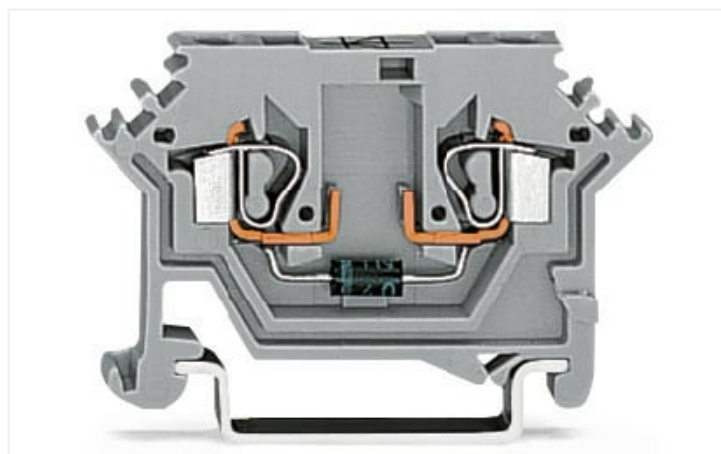

Similar to illustration

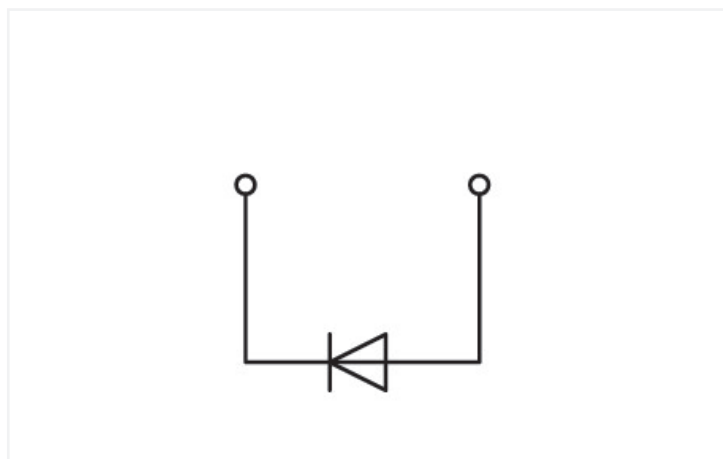

Electrical data

| Ratings per | IEC/EN 60947-7-1 | | |
|----------------------|------------------|-----|----|
| Overvoltage category | III | III | II |
| Pollution degree | 3 | 2 | 2 |
| Nominal voltage | - | - | - |
| Rated surge voltage | - | - | - |
| Rated current | - | - | - |

General information

| | |
|-----------------|--------|
| Nominal voltage | 250 V |
| Reverse voltage | 1000 V |

Connection data

| | |
|----------------------------|---|
| Connection points | 2 |
| Total number of potentials | 1 |
| Number of levels | 1 |

Connection 1

| | |
|---------------------------------|--------------------|
| Connection technology | CAGE CLAMP® |
| Actuation type | Operating tool |
| Connectable conductor materials | Copper Aluminum |

Connection 1

Connectable conductor materials (note)

Terminating Aluminum Conductors

WAGO spring clamp terminal blocks are suitable for solid aluminum conductors up to 4 mm²/12 AWG if WAGO "Alu-Plus" Contact Paste [249-130](https://www.wago.com/249-130) is used for termination.

"Alu-Plus" Contact Paste Advantages:

- Automatically destroys the oxide film during clamping.
- Prevents fresh oxidation at the clamping point.
- Prevents electrolytic corrosion between aluminum and copper conductors (in the same terminal block).
- Provides long-term protection against corrosion.

Using terminal blocks with CAGE CLAMP® Spring Pressure Connection Technology, **aluminum conductors must first be cleaned with a blade** and then immediately be inserted into the clamping units filled with "Alu-Plus" Contact Paste.

It is also possible to apply WAGO "Alu-Plus" **additionally** on the whole surface of the aluminum conductor before termination.

Please note that the nominal currents must be adapted to the reduced conductivity of the aluminum conductors::

2.5 mm² = 16 A

4 mm² = 22 A

| | |
|-------------------------|--|
| Solid conductor | 0.08 ... 2.5 mm ² / 28 ... 14 AWG |
| Fine-stranded conductor | 0.08 ... 2.5 mm ² / 28 ... 14 AWG |
| Strip length | 8 ... 9 mm / 0.31 ... 0.35 inches |
| Wiring direction | Front-entry wiring |

Physical data

| | |
|-----------------------------------|----------------------|
| Width | 5 mm / 0.197 inches |
| Height | 50 mm / 1.969 inches |
| Depth from upper-edge of DIN-rail | 28 mm / 1.102 inches |

Mechanical data

| | |
|---------------|-----------------|
| Design | horizontal type |
| Mounting type | DIN-35 rail |
| Marking level | Side marking |

Material data

| | |
|-----------------------------|--|
| Note (material data) | Information on material specifications can be found here |
| Color | gray |
| Material group | I |
| Insulation material | Polyamide (PA66) |
| Flammability class per UL94 | V0 |
| Fire load | 0.167 MJ |
| Weight | 5.2 g |

Environmental requirements

| | |
|----------------------------------|-----------------|
| Processing temperature | -35 ... +85 °C |
| Continuous operating temperature | -60 ... +105 °C |

Commercial data

| | |
|-----------------------|----------------------------------|
| Product Group | 1 (Rail Mounted Terminal Blocks) |
| eCl@ss 10.0 | 27-14-11-27 |
| eCl@ss 9.0 | 27-14-11-27 |
| ETIM 8.0 | EC000903 |
| ETIM 7.0 | EC000903 |
| PU (SPU) | 100 (10) pcs |
| Packaging type | Box |
| Country of origin | DE |
| GTIN | 4045454194680 |
| Customs tariff number | 85369010000 |

Environmental Product Compliance

| | |
|---|--|
| CAS-No. | 7439-92-1 79-94-7 |
| REACH Candidate List Substance | 2,2',6,6'-tetrabromo-4,4'-isopropylidenediphenol Lead |
| RoHS Compliance Status | Compliant,With Exemption |
| RoHS Exemption | 7(a) 7(c)-I |
| SCIP notification number (Austria) | 087740d4-1d9f-47d8-b811-e42e41c9a402 |
| SCIP notification number (Belgium) | b2837fe0-480b-42d4-ac2d-33fa9f5410c0 |
| SCIP notification number (Bulgaria) | 5ee28953-ec1f-4120-b376-2461696e91c7 |
| SCIP notification number (Czech Republic) | f66118eb-12b2-4192-b2ce-c91c0c5128fd |
| SCIP notification number (Denmark) | 4356335d-f5a7-4e2f-a6da-9fef8ae51529 |
| SCIP notification number (Finland) | 3b740a49-f433-4581-a35d-26ba9ec2bbd5 |
| SCIP notification number (France) | 19cf2d16-fe7b-41e6-bdbe-95bcb58b6dd5 |
| SCIP notification number (Germany) | 74ef6921-a087-40de-bac0-18fc184c93f7 |
| SCIP notification number (Hungary) | 9d41a367-1c64-48ca-89ff-2a70d6fb5efc |
| SCIP notification number (Italy) | 7785d605-cfef-4b28-8cd8-57c17d81e240 |
| SCIP notification number (Netherlands) | 581485a7-ae6b-4808-be00-ef2aa414d21d |
| SCIP notification number (Poland) | bc6b8b31-8c47-45aa-94ad-c259c7dd95d1 |
| SCIP notification number (Romania) | b7d2eb69-e55b-4250-acda-9db98de3b22e |
| SCIP notification number (Sweden) | a6399e95-819a-4e57-930c-2966f27ecb73 |

Approvals / Certificates

General approvals



| Approval | Standard | Certificate Name |
|---------------------------------|----------|------------------|
| CCA DEKRA Certification B.V. | EN 60947 | 2157201.01 |

Declarations of conformity and manufacturer's declarations

| Approval | Standard | Certificate Name |
|---|----------|------------------|
| EU-Declaration of Confor- mity WAGO GmbH & Co. KG | - | - |
| UK-Declaration of Confor- mity WAGO GmbH & Co. KG | - | - |

Approvals for marine applications



| Approval | Standard | Certificate Name |
|---|----------|------------------|
| ABS American Bureau of Ship- ping | EN 60947 | 20-HG1941090-PDA |
| DNV GL Det Norske Veritas, Ger- manischer Lloyd | - | TAE00001V2 |

Downloads

Environmental Product Compliance

| Compliance Search |
|--|
| Environmental Product Compliance 280-613/281-411 |

Documentation

| Additional Information |
|-------------------------------------|
| Technical Section pdf 2240.62 KB |

CAD/CAE-Data

| CAD data |
|---------------------------------|
| 2D/3D Models 280-613/281-411 |

| CAE data |
|--------------------------------------|
| EPLAN Data Portal 280-613/281-411 |
| WSCAD Universe 280-613/281-411 |
| ZUKEN Portal 280-613/281-411 |

1 Compatible Products

1.1 Required Accessories

1.1.1 End plate

1.1.1.1 End plate



Item No.: 280-330
End and intermediate plate; 2.5 mm thick;
gray

Item No.: 280-331
End and intermediate plate; 2.5 mm thick;
orange

Item No.: 280-338
Separator plate; 2 mm thick; oversized;
gray

Item No.: 280-328
Separator plate; 2 mm thick; oversized;
orange

1.2 Optional Accessories

1.2.1 DIN-rail

1.2.1.1 Mounting accessories



Item No.: 210-196

Aluminum carrier rail; 35 x 8.2 mm; 1.6 mm thick; 2 m long; unslotted; similar to EN 60715; silver-colored



Item No.: 210-198

Copper carrier rail; 35 x 15 mm; 2.3 mm thick; 2 m long; unslotted; according to EN 60715; copper-colored



Item No.: 210-508

Steel carrier rail; 35 x 15 mm; 1.5 mm thick; 2 m long; slotted; galvanized; similar to EN 60715; silver-colored



Item No.: 210-197

Steel carrier rail; 35 x 15 mm; 1.5 mm thick; 2 m long; slotted; similar to EN 60715; silver-colored



Item No.: 210-506

Steel carrier rail; 35 x 15 mm; 1.5 mm thick; 2 m long; unslotted; galvanized; similar to EN 60715; silver-colored



Item No.: 210-114

Steel carrier rail; 35 x 15 mm; 1.5 mm thick; 2 m long; unslotted; similar to EN 60715; silver-colored



Item No.: 210-118

Steel carrier rail; 35 x 15 mm; 2.3 mm thick; 2 m long; unslotted; according to EN 60715; silver-colored



Item No.: 210-115

Steel carrier rail; 35 x 7.5 mm; 1 mm thick; 2 m long; slotted; according to EN 60715; "Hole width 18 mm; silver-colored



Item No.: 210-112

Steel carrier rail; 35 x 7.5 mm; 1 mm thick; 2 m long; slotted; according to EN 60715; "Hole width 25 mm; silver-colored



Item No.: 210-504

Steel carrier rail; 35 x 7.5 mm; 1 mm thick; 2 m long; slotted; galvanized; according to EN 60715; silver-colored



Item No.: 210-113

Steel carrier rail; 35 x 7.5 mm; 1 mm thick; 2 m long; unslotted; according to EN 60715; silver-colored



Item No.: 210-505

Steel carrier rail; 35 x 7.5 mm; 1 mm thick; 2 m long; unslotted; galvanized; according to EN 60715; silver-colored

1.2.2 Ferrule

1.2.2.1 Ferrule



Item No.: 216-301

Ferrule; Sleeve for 0.25 mm² / AWG 24; insulated; electro-tin plated; yellow



Item No.: 216-302

Ferrule; Sleeve for 0.34 mm² / 22 AWG; insulated; electro-tin plated; light turquoise



Item No.: 216-201

Ferrule; Sleeve for 0.5 mm² / 20 AWG; insulated; electro-tin plated; white



Item No.: 216-101

Ferrule; Sleeve for 0.5 mm² / AWG 22; un-insulated; electro-tin plated; silver-colored



Item No.: 216-202

Ferrule; Sleeve for 0.75 mm² / 18 AWG; insulated; electro-tin plated; gray



Item No.: 216-102

Ferrule; Sleeve for 0.75 mm² / AWG 20; un-insulated; electro-tin plated; silver-colored



Item No.: 216-203

Ferrule; Sleeve for 1 mm² / AWG 18; insulated; electro-tin plated; red



Item No.: 216-103

Ferrule; Sleeve for 1 mm² / AWG 18; un-insulated; electro-tin plated



Item No.: 216-204

Ferrule; Sleeve for 1.5 mm² / AWG 16; un-insulated; electro-tin plated; black



Item No.: 216-104

Ferrule; Sleeve for 1.5 mm² / AWG 16; un-insulated; electro-tin plated; silver-colored

1.2.3 Installation

1.2.3.1 Cover



Item No.: 709-153

Cover; Type 1; suitable for cover carrier, type 1; 1 m long; transparent

1.2.3.2 Cover carrier



Item No.: 709-167
 Cover carrier; Type 1; incl. fixing/retaining screws and knurled nut; suitable for 279 to 282 and 880 Series rail-mounted terminal blocks; suitable for 264 Series miniature rail-mounted terminal blocks; suitable for 270 Series sensor and actuator terminal blocks; gray

1.2.3.3 Mounting accessories



Item No.: 209-106
 Mounting carrier; for isolated mounting on DIN 35 rails; gray



Item No.: 249-116
 Screwless end stop; 6 mm wide; for DIN-rail 35 x 15 and 35 x 7.5; gray

1.2.4 Insulation stop

1.2.4.1 Insulation stop



Item No.: 280-470
 Insulation stop; 0.08 - 0.2 mm² "s" (0.14 mm² "f-st"); 5 pieces/strip; white



Item No.: 280-471
 Insulation stop; 0.25 - 0.5 mm²; 5 pieces/strip; light gray



Item No.: 280-472
 Insulation stop; 0.75 - 1 mm²; 5 pieces/strip; black

1.2.5 Jumper

1.2.5.1 Jumper



Item No.: 280-490
 Jumper; 10-way; insulated; gray



Item No.: 280-482
 Jumper; 2-way; insulated; gray



Item No.: 280-492
 Jumper; 2-way; insulated; gray



Item No.: 280-483
 Jumper; 3-way; insulated; gray



Item No.: 280-484
 Jumper; 4-way; insulated; gray



Item No.: 280-485
 Jumper; 5-way; insulated; gray



Item No.: 709-110
 Wire commoning chain; 2.5 mm²; insulated; black



Item No.: 709-111
 Wire commoning chain; 2.5 mm²; insulated; black



Item No.: 709-112
 Wire commoning chain; 2.5 mm²; insulated; black



Item No.: 210-103
 Wire commoning chain; insulated; black



Item No.: 210-123
 Wire commoning chain; insulated; blue

1.2.6 Marking

1.2.6.1 Marker



Item No.: 793-5501
 WMB marking card; as card; for terminal block width 5 - 17.5 mm; stretchable 5 - 5.2 mm; plain; snap-on type; white



Item No.: 793-501
 WMB marking card; as card; not stretchable; plain; snap-on type; white



Item No.: 2009-115
 WMB-inline; for Smart Printer; 1500 pieces on roll; stretchable 5 - 5.2 mm; plain; snap-on type; white

1.2.7 Protective warning marker

1.2.7.1 Cover



Item No.: 280-415

Protective warning marker; for 5 terminal blocks; with high-voltage symbol, black; yellow

1.2.8 Test and measurement

1.2.8.1 Testing accessories



Item No.: 249-142

L-type end module; modular; with rigid contact pin; End module; 1,50 mm²; gray



Item No.: 249-143

L-type spacer module; modular; e.g., bridging commoned terminal blocks; gray



Item No.: 249-141

L-type test plug module; modular; with spring-loaded contact pin; Center module; 1,50 mm²; gray

1.2.9 Tool

1.2.9.1 Operating tool



Item No.: 210-658

Operating tool; Blade: 3.5 x 0.5 mm; with a partially insulated shaft; angled; short; multicoloured



Item No.: 210-720

Operating tool; Blade: 3.5 x 0.5 mm; with a partially insulated shaft; multicoloured



Item No.: 210-657

Operating tool; Blade: 3.5 x 0.5 mm; with a partially insulated shaft; short; multicoloured

Installation Notes

Commoning

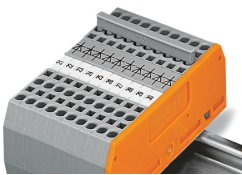

Commoning using comb-style jumper bars:

Push comb-style jumper bars down until fully inserted.

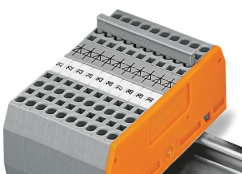

These diode terminal blocks have been specially developed for custom diode circuits, such as lamp test and collective fault signal circuits.



Open diode gates can be created using the following terminal blocks:
280-613/281-410 or 280-613/281-411