



Force H3X Energy Storage System

User Manual

(FH3X-3.6K/5K/6K/8K-HY-1P-5/10/15/20)

Information Version: 1.14
5PMPA08-20002

Legal Information

Copyright©2025 Pylon Technologies Co., Ltd. All rights reserved.

Any reproduction or distribution of this manual or any part of this manual, or any uploading of this manual to a third party website, in any form by any means, without the prior written consent of Pylon Technologies Co., Ltd., is prohibited.

Disclaimer

The manual contains instructions for the use of the product. All the pictures and charts in this manual are for description and explanation only. Pylon Technologies Co., Ltd. reserves the right to change the information in the manual which is subject to change without further notice.

Please read this manual carefully before using the product and keep this manual for further reference. Failure to use the product in accordance with the manual may result in serious injuries, property damages and may void the warranty, for which Pylon Technologies Co., Ltd. shall not be liable.

Pylon Technologies Co., Ltd. makes no representations or warranties express or implied, with respect to all the information in this manual.

In the event of any conflicts between this manual and the applicable law, the latter prevails.

The final interpretation of this manual belongs to Pylon Technologies Co., Ltd.

About this Manual

Purpose

This manual describes the Force H3X (Hereinafter referred to as FH3X) energy storage system from Pylontech in terms of its overview, installation, commissioning, maintenance, etc. Please read this manual before installing the battery and follow the instructions carefully during installation. In case of any confusion, please contact Pylontech immediately for advice and clarification (Contact information can be found on the back cover of the manual).

Product Model

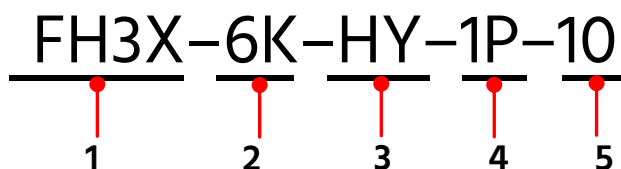

Model Identifier

The following are the system model naming rules, taking FH3X-6K-HY-1P-10 as an example:



No.	Meaning	Explanation
1	Product series name	FH3X Series
2	Grid-connected power	Several kinds of power level (kW): 3.6, 5, 6, 8
3	Machine type	HY: Hybrid
4	Grid type	1P: Single-phase
5	System capacity (5/10/15/20)	Single battery module capacity (kWh): 5.12. The system contains 1~4 battery modules with 4 system capacity (kWh): 5.12, 10.24, 15.36, 20.48

Explanation of Symbols

Symbol	Description
	Danger: Indicates a hazard with a high level of risk which, if not avoided, will result in death or serious injury.
	Warning: Indicates a hazard with a medium level of risk which, if not avoided, could result in death or serious injury.
	Caution: Indicates a hazard with a low level of risk which, if not avoided, could result in minor or moderate injury.

NOTICE	<p>Notice: Indicates a potentially hazardous situation which, if not avoided, could result in equipment damage, data loss, performance deterioration, or unanticipated results.</p> <p>NOTICE is used to address practices not related to personal injury.</p>
 NOTE	<p>Note: Indicates additional information, emphasized contents, or important points helping you use the product better.</p>

Abbreviations

Abbreviation	Designation
Pylontech	Pylon Technologies Co., Ltd.
AC	Alternating Current
DC	Direct Current
QC	Quality Control
BMS	Battery Management System
BMU	Battery Management Unit
PCS	Power Conversion System
SOC	State of Charge
SOH	Battery State of Health, in percent
UPS	Uninterruptible Power Supply
BESS	Battery Energy Storage System
ESS	Energy Storage System
EMS	Energy Management System
PMU	Power Management Unit
CMU	Control Management Unit
SPD	Surge Protecting Device
EU	European Union
DOD	Depth of Discharge
LEMS	Local Energy Management System
MCU	Microcontroller Unit

Contents







Legal Information	I
About this Manual	II
Purpose	II
Product Model.....	II
Explanation of Symbols.....	II
Abbreviations	III
Contents	IV
1 Safety	1
1.1 Label Description	1
1.2 Personal Requirements	2
1.3 General Safety	2
2 System Introduction	5
2.1 System Overview	5
2.1.1 Brief Introduction.....	5
2.1.2 Product Model.....	5
2.1.3 Applicable Grid Type.....	5
2.2 Component Description.....	6
2.2.1 Power Controller	6
2.2.2 Battery Module.....	9
3 Installation	11
3.1 Checking Before the Installation.....	11
3.2 Preparing Tools and Instruments.....	13
3.3 Selecting the Installation Sites	14
3.3.1 Working Environment Requirements.....	14
3.3.2 Installation Space Requirements	15
3.3.3 Installation Foundation Requirements.....	15
3.4 System Installation	16
3.4.1 Mounting the Battery Base	16
3.4.2 Installing the Battery Module onto the Base.....	18
3.4.3 Installing the Power Controller onto the Battery Module.....	19

3.4.4	Installing the Metal Brackets for the System	22
3.4.5	Installing the Anti-Toppling Brackets for the System	24
4	Cable Connection.....	27
4.1	Safety Instructions	27
4.2	Preparing Cables.....	28
4.3	System Diagram	29
4.3.1	Electrical Wiring Diagram.....	29
4.3.2	Standard Wiring Diagram.....	29
4.3.3	Australia Wiring Diagram.....	30
4.4	Grounding Connection.....	30
4.5	AC Connector Assembly and Connection.....	33
4.5.1	AC Connector Type A Assembly and Connection.....	33
4.5.2	AC Connector Type B Assembly and Connection.....	37
4.5.3	AC Switch Types	39
4.5.4	EPS Load Information	40
4.6	PV Connector Assembly and Connection	41
4.6.1	PV Connector Assembly.....	41
4.6.2	PV Connector Connection.....	42
4.7	EPO Connection	43
4.8	Heat Pump Connection.....	44
4.9	CT Connection	45
4.10	DRM (Only DRM0 is Available).....	46
4.11	Communication Connector Assembly and Connection	48
4.11.1	Communication Connector Assembly.....	48
4.11.2	Communication Connector Connection.....	51
5	Commissioning.....	52
5.1	System Turning On.....	52
5.2	Energy Management.....	54
5.2.1	WI-FI Information.....	54
5.2.2	App Download.....	55
5.2.3	Working Mode.....	56
5.2.4	Commissioning.....	57
5.2.5	Charge/Discharge Time Control	59

5.3	LED Introduction and Debug.....	61
6	Maintenance	64
6.1	System Turning Off.....	64
6.2	System Maintenance	66
6.3	Troubleshooting.....	67
6.4	Replacement of Main Components among the BESS.....	71
6.4.1	Replacement of Battery Module.....	71
6.4.2	Replacement of Power Controller	74
7	Expansion Services	75
8	Shipment and Storage.....	76
8.1	Shipment.....	76
8.2	Storage	76
9	Warranty Services and Repair	77
10	Disposal	78
11	Technical Specifications	79
11.1	System Specifications.....	79
11.2	Battery Specifications	83

1 Safety

1.1 Label Description

Icon	Meaning	Icon	Meaning
	Read the manual before installing and operating the product.		Do not connect the positive and negative reversely.
	General warning label indicating potential hazards.		Keep away from flame or ignition sources.
	Warning: electric shock.		Keep away from children.
	Warning: flammable materials.		Label for Waste Electrical and Electronic Equipment (WEEE) Directive (2012/19/EU).
	Warning: Do not touch the enclosure of the operating product.		The system meets the requirements of the applicable EU directives.
	Recycle label.		The certificate label for Safety by TÜV SÜD.
	Do not touch any inner live parts until 5 minutes after disconnection from all external power supplies!		The Regulatory Compliance Mark (RCM) is a trade mark owned by the electrical regulator (Regulatory Authorities (RAs)) and Australian Communications Media Authority (ACMA).

1.2 Personal Requirements

Qualified personnel must have the following skills:

- Training in the installation and commissioning of the electrical system, as well as the dealing with hazards.
- Knowledge of the manual and other related documents.
- Knowledge of the local regulations and directives.

1.3 General Safety

Declaration

This system is only operated by authorized personnel. Read all safety instructions carefully prior to any work and follow these instructions at all times when working with the system.

Incorrect operation or work may cause:

- Injury or death to the operator or a third party.
- Damage to the system hardware and other properties belonging to the operator or a third party.

General Requirements

DANGER

Danger: Batteries deliver electric power, resulting in burns or a fire hazard when short circuit or incorrect installment occurs.

DANGER

Danger: Lethal voltages are present in the battery terminals and cables. Severe injuries or death may occur if you touch the cables and terminals.

WARNING

Warning: Do not open or deform the battery module, otherwise the product will be out of warranty scope.

WARNING

Warning: Whenever operating the battery system, wear suitable personal protective equipment (PPE) such as rubber gloves, rubber boots and goggles.

 **WARNING**

Warning: For battery installation, the installer shall refer to NFPA70 or similar local installation standard for operation.

 **WARNING**

Warning: Pulling out the connectors while the system is working could lead to battery system damage or personal injury. Do not pull out the connectors while system is in operation.

 **CAUTION**

Caution: Improper settings or maintenance can permanently damage the battery.

 **CAUTION**

Caution: Battery needs to be recharged within 12 hours, after fully discharged.

 **WARNING**

Warning: To reduce the risk of fire, over-current protective devices (OCPD) are required for circuits connected to the FH3X system. The DC OCPD shall be installed per local requirements. All photovoltaic source and output circuit conductors shall have isolators that comply with the NEC Article 690, Part II.

 **CAUTION**

Caution: Risk of electric shock, do not remove cover. There is no user serviceable parts inside, refer servicing to qualified and accredited service technicians

 **CAUTION**

Caution: The PV array supplies a DC voltage when they are exposed to sunlight.

 **CAUTION**

Caution: The surface temperature of the inverter can reach up to 60 °C. To avoid risk of burns, do not touch the surface of the FH3X system while it's operating. Inverter must be installed out of the reach of children.

 **CAUTION**

Caution: PV module used with FH3X system must have an IEC 61730 Class A rating.

 **WARNING**

Warning: Operations below must be accomplished by licensed technician or Pylontech authorized person.

 **WARNING**

Warning: The BACK-UP terminal of FH3X system is not allowed to connect to the grid.

 **WARNING**

Warning: No user-serviceable parts inside. Internal maintenance is not authorized; servicing must be performed only by a Pylontech-authorized representative.

2 System Introduction

2.1 System Overview

2.1.1 Brief Introduction

The FH3X product are designed with advanced modular design concept. It integrates photovoltaic, inverter, energy storage as a whole, without additional switch box, junction box and other equipment. The all-in-one power controller is directly connected to the stacked battery modules form a complete light storage integrated system solutions for customers, which provides the greatest choice for the application of the energy storage system and the convenience of installation.

2.1.2 Product Model

Model Identifier

The following are the system model naming rules, taking FH3X-6K-HY-1P-10 as an example:

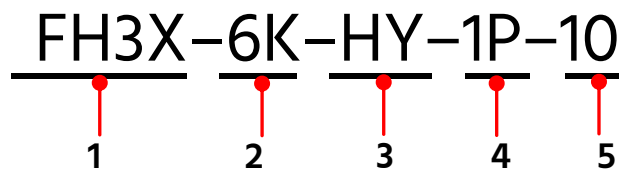

No.	Meaning	Explanation
1	Product series name	FH3X Series
2	Grid-connected power	Several kinds of power level (kW): 3.6, 5, 6, 8
3	Machine type	HY: Hybrid
4	Grid type	1P: Single-phase
5	System capacity (5/10/15/20)	Single battery module capacity (kWh): 5.12. The system has 1/2/3/4 battery modules, with a system capacity of 5.12/10.24/15.36/20.48 kWh, and the corresponding values are 5/10/15/20.

2.1.3 Applicable Grid Type

The applicable grid types of the FH3X series are TN-S, TN-C, TN-C-S.

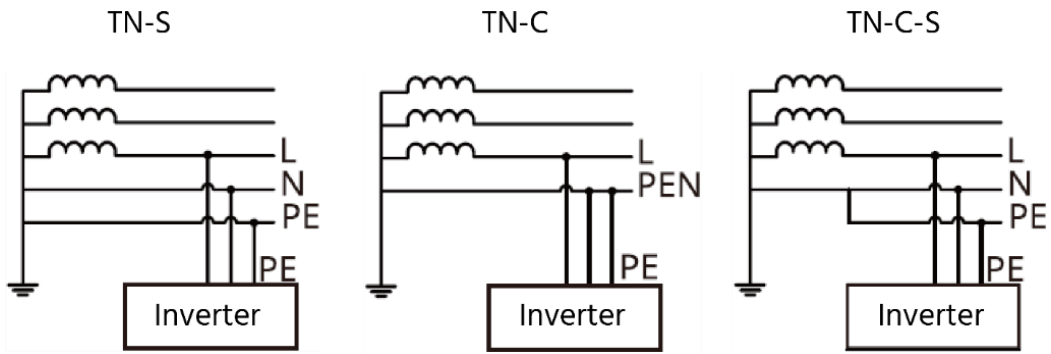

For different country or area, the color of L、N、PE may be different.

L	N	PE
Red/black/brown	Blue	Green & yellow

2.2 Component Description

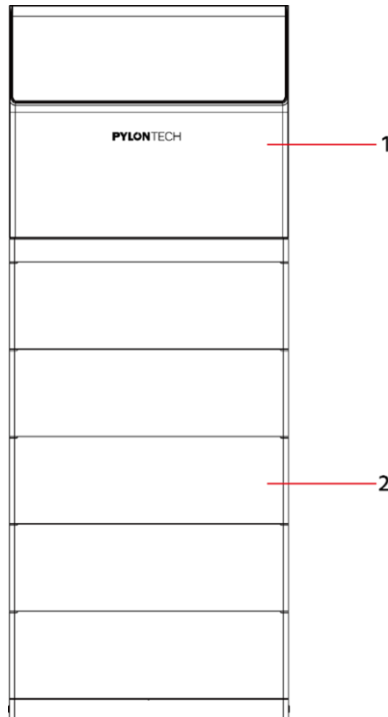

NOTE: The quantity of the battery modules is based on your practical system.

No.	Name	Description
1	Power controller	(>>> see <i>Section 2.2.1 Power Controller</i>)
2	Battery module	(>>> see <i>Section 2.2.2 Battery Module</i>)

2.2.1 Power Controller

Front View

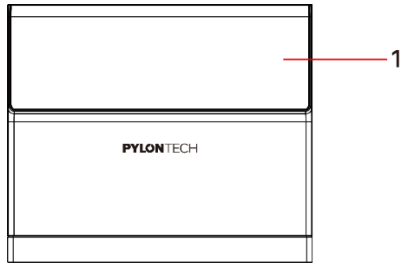

No.	Name	Description
1	LED Display	(>>> see <i>Section 5.3 LED Introduction and Debug</i>)

Left side view

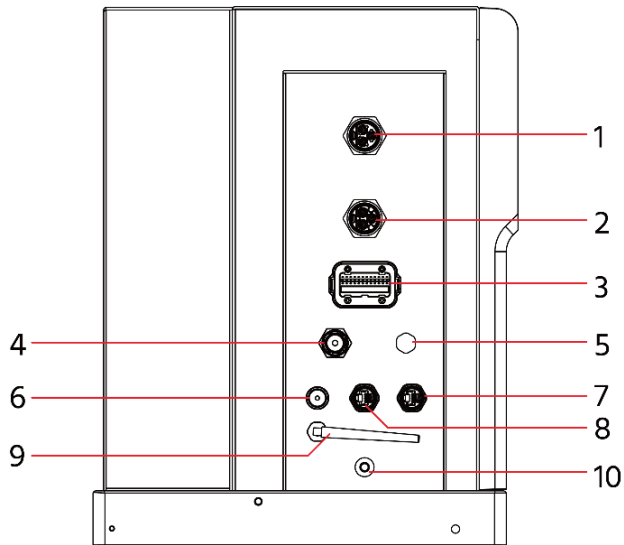

No.	Name	Description										
1	AC GRID terminal	AC terminal for connection to the utility grid										
2	BACK-UP terminal	AC terminal for Backup loads										
3	COM terminal	Connector for meter/CT, or other equipment, or parallel interface For details of the terminal pins, see <i>Section 4.11.1 Communication Connector Assembly</i> .										
4	CONTROL	<p>Connector for relay control of parallel connection and external heat pump on/off Rated voltage: 230V; Rated current: 2A Heat pump signal cable:</p> <table border="1"> <tbody> <tr> <td>PIN1</td> <td>PUMP+</td> <td rowspan="2">Control heat pump start-up</td> </tr> <tr> <td>PIN2</td> <td>PUMP-</td> </tr> <tr> <td>PIN3</td> <td>Outrelay+</td> <td rowspan="2">Control EPS switchover</td> </tr> <tr> <td>PIN4</td> <td>Outrelay-</td> </tr> </tbody> </table>	PIN1	PUMP+	Control heat pump start-up	PIN2	PUMP-	PIN3	Outrelay+	Control EPS switchover	PIN4	Outrelay-
PIN1	PUMP+	Control heat pump start-up										
PIN2	PUMP-											
PIN3	Outrelay+	Control EPS switchover										
PIN4	Outrelay-											

No.	Name	Description
5	Ventilation valve	-
6	START	1. Black-start: Short press the button for 1 second to switch on the system via the battery. 2. Light on: When the system is switched on, long press for 2-3 seconds can light up the screen.
7	LAN terminal	Connector for network
8	EMS	Connector for EMS communication and commissioning
9	WIFI	WiFi antenna
10	Ground point	Connector for grounding cable.

Right side view

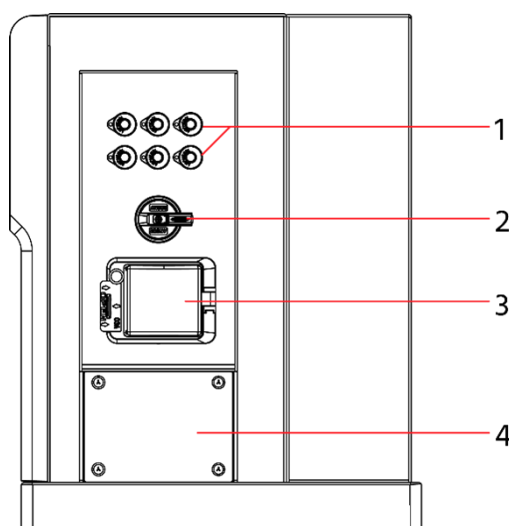

No.	Name	Description									
1	PV terminals	Positive and negative DC input connectors Can be removed by the PV Terminal Removal Tool (see in the packing list >>> see Section 3.1 Checking Before the Installation).									
2	PV SWITCH	Isolating switch for PV It is recommended to additionally lock the switch for maintenance shutdowns. PV switch specifications: <table border="1" data-bbox="641 1872 1406 2045"> <thead> <tr> <th>No</th> <th>Parameters</th> <th>Value</th> </tr> </thead> <tbody> <tr> <td>1</td> <td>Rated insulation voltage</td> <td>1.5kV</td> </tr> <tr> <td>2</td> <td>Rated impulse withstand voltage</td> <td>8KV</td> </tr> </tbody> </table>	No	Parameters	Value	1	Rated insulation voltage	1.5kV	2	Rated impulse withstand voltage	8KV
No	Parameters	Value									
1	Rated insulation voltage	1.5kV									
2	Rated impulse withstand voltage	8KV									

No.	Name	Description																		
		<table border="1"> <tr> <td>3</td> <td>Suitability for isolation</td> <td>Yes</td> </tr> <tr> <td>4</td> <td>Rated operational current</td> <td>32A</td> </tr> <tr> <td>5</td> <td>Utilization category and/or PV utilization category</td> <td>DC-PV2</td> </tr> <tr> <td>6</td> <td>Rated short-time withstand current (Icw)</td> <td>1.5KA (1S)</td> </tr> <tr> <td>7</td> <td>Rated short-circuit making capacity (Icm)</td> <td>2KA</td> </tr> <tr> <td>8</td> <td>Rated breaking capacity</td> <td>8KA</td> </tr> </table>	3	Suitability for isolation	Yes	4	Rated operational current	32A	5	Utilization category and/or PV utilization category	DC-PV2	6	Rated short-time withstand current (Icw)	1.5KA (1S)	7	Rated short-circuit making capacity (Icm)	2KA	8	Rated breaking capacity	8KA
3	Suitability for isolation	Yes																		
4	Rated operational current	32A																		
5	Utilization category and/or PV utilization category	DC-PV2																		
6	Rated short-time withstand current (Icw)	1.5KA (1S)																		
7	Rated short-circuit making capacity (Icm)	2KA																		
8	Rated breaking capacity	8KA																		
3	BAT SWITCH	<p>Battery switch for battery connection</p> <p>It is recommended to additionally lock the switch to prevent accidental contact by personnel.</p> <p>Bat switch specifications:</p> <table border="1"> <thead> <tr> <th>No</th> <th>Parameters</th> <th>Value</th> </tr> </thead> <tbody> <tr> <td>1</td> <td>Rated insulation voltage</td> <td>1200V</td> </tr> <tr> <td>2</td> <td>Rated impulse withstand voltage</td> <td>6KV</td> </tr> <tr> <td>3</td> <td>Suitability for isolation</td> <td>Yes</td> </tr> <tr> <td>4</td> <td>Rated operational current</td> <td>63A</td> </tr> <tr> <td>5</td> <td>Rated breaking capacity</td> <td>6KA</td> </tr> </tbody> </table>	No	Parameters	Value	1	Rated insulation voltage	1200V	2	Rated impulse withstand voltage	6KV	3	Suitability for isolation	Yes	4	Rated operational current	63A	5	Rated breaking capacity	6KA
No	Parameters	Value																		
1	Rated insulation voltage	1200V																		
2	Rated impulse withstand voltage	6KV																		
3	Suitability for isolation	Yes																		
4	Rated operational current	63A																		
5	Rated breaking capacity	6KA																		
4	FUSE CASE	Battery main circuit fuse(ASTN A226010-80A)																		

2.2.2 Battery Module

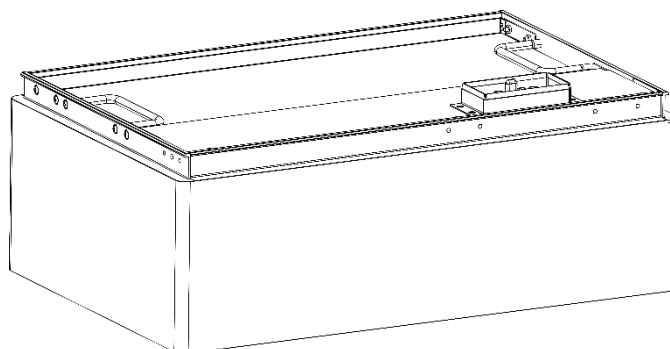

The FH10050 battery module, which first appeared in the release of another Pylontech battery system ForceH3. The FH3X energy storage system is upgraded based on the ForceH3 system, sharing one battery module, which is a key feature of the FH3X energy storage system. A single battery module is rated at 102.4V/50Ah, and multiple battery modules are stacked and used in

series.

3 Installation

3.1 Checking Before the Installation

Checking the Outer Packing and Deliverables

- After receiving the product, check the outer packing for damage, such as holes, cracks, deformation and so on. If any damage is found, contact the local retailer as soon as possible.
- After unpacking the product, check that the deliverables are complete. If any item is missing or damaged, contact the local retailer as soon as possible.

Packing List

Box 1-Power Controller

Item	Name	Specification	Set
A	Power Controller	/	1
B	Base	/	1
C	Anti-toppling bracket	86*70*22	2
D	Lifting Handle	M8*113	2
E	Footrest	/	4
F	1 Battery metal bracket left	235.1*25.7*25.7	1
	1 Battery metal bracket right	235.1*25.7*25.7	1
	2 Battery metal bracket left	403.3*25.7*25.7	1
	2 Battery metal bracket right	403.3*25.7*25.7	1
	3 Battery metal bracket left	571.5*25.7*25.7	1
	3 Battery metal bracket right	571.5*25.7*25.7	1
G	Multi-function Terminal	90*60.2*Diameter 48	1
H	CT	/	1
I	AC Back-up Connector Type A or AC Back-up Connector Type B	/	1
J	AC Grid Connector Type A or AC Grid Connector Type B	/	1
K	PV Connector Negative	58*Diameter 21.7	3
L	PV Connector Positive	59.5*Diameter 21.7	3
M	Heat Pump Connector	48*Diameter 20.5	1
N	RJ45 Connector	43.9*Diameter 29.2	2
O	Documents	Quick Installation Instructions and Warranty Card	2
P	Ground Screws	M6*16	1
Q	Screws	M4*8	12
R	Expansion bolts	M8*60	6

S	Step Screws	M4*22	2
T	Hex Wrench	/	1
U	AC Unlocking Tool	/	1
V	PV Terminal Removal Tool	/	1





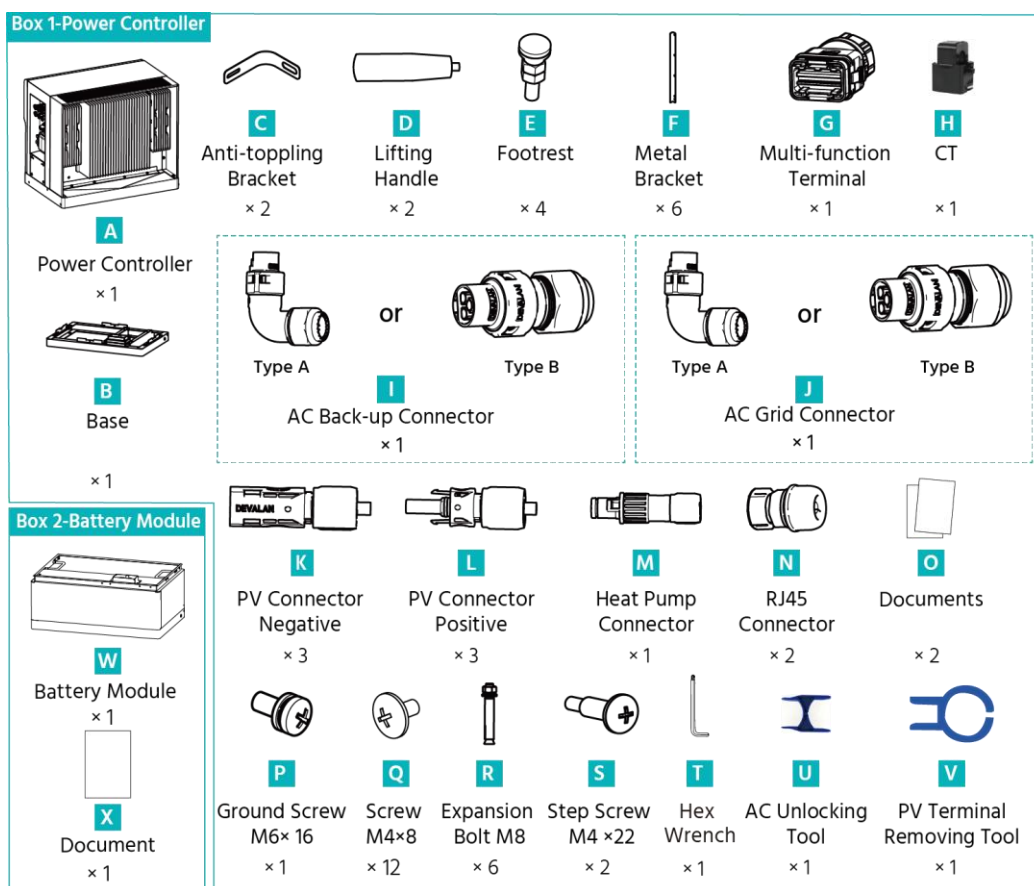

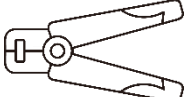
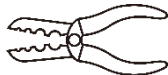
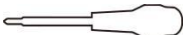
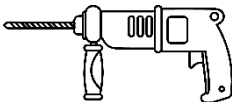

Box 2-Battery Module

Item	Name	Specification	Set
W	Battery Module	/	1
X	Document	Warranty Card	1

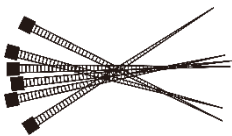

3.2 Preparing Tools and Instruments

Tools and Instruments

Type	Tools and Instruments		
Installation			
	Wire Cutter	Crimping Plier	Wire Stripper
			
	Screwdriver	Hammer Drill	1000VDC Multimeter
			
	Adjustable Wrench	Socket Wrench Set	Cable Ties
Personal protective equipment (PPE)			
	Insulated Gloves	Safety Goggles	Safety Shoes
			
	Anti-arc Flash Suit		

NOTE: Use properly insulated tools to prevent accidental electric shock or short circuits. If insulated tools are not available, cover the entire exposed metal surfaces with available insulated alternatives, except their tips, with electrical tape.

3.3 Selecting the Installation Sites

3.3.1 Working Environment Requirements

Cleaning

 **DANGER**

Danger: Before installation and system power on, the dust and iron scurf must be removed to keep a clean environment.

The system cannot be installed in desert area without an enclosure to prevent from sand.

 **DANGER**

Danger: Battery module has active DC power at terminals all the time. Be careful to handle the modules.

 **CAUTION**

Caution: The IP rating of the system is IP65. But please avoid frost or direct sunlight. Out of the working temperature range will cause the battery system high / low temperature alarm or protection which will further lead to the cycle life reduction. According to the environment requirements, a cooling system or heating system should be installed when necessary.

Fire-extinguisher System

 **DANGER**

Danger: The fire-extinguisher system must be equipped for safety purpose. The fire system needs to be checked regularly to ensure a normal working status. Regarding to the using and maintenance requirements, please follow local fire equipment guidance.

FH3X is not equipped with a fire alarm system, please prepare a sound-light alarm in the system installation area. Minimum loudness of 85 dB(A) in accordance with DIN EN 14604, measured at a distance of 3 m, but not more than 110 dB(A). The frequency is limited to a maximum of 3.5 kHz.

Grounding System

 **DANGER**

Danger: Before the system installation, ensure that the grounding point of the base is stable and reliable. If the system is installed in an independent equipment cabin (e.g. container), the grounding of the cabin must be stable and reliable.

The resistance of the grounding system must be $\leq 100 \text{ m}\Omega$.

Clearance

Minimum clearance to heat source shall be more than 2 meters.

Minimum clearance to the walls shall be more than 0.04 meters.

Minimum clearance between battery strings shall be more than 0.3 meters.

3.3.2 Installation Space Requirements

WARNING

Warning: FH3X system must not be immersed in water.

The FH3X system can be installed indoors or outdoors. FH3X system must not be immersed in water. The battery base cannot be exposed to rain or other water sources.

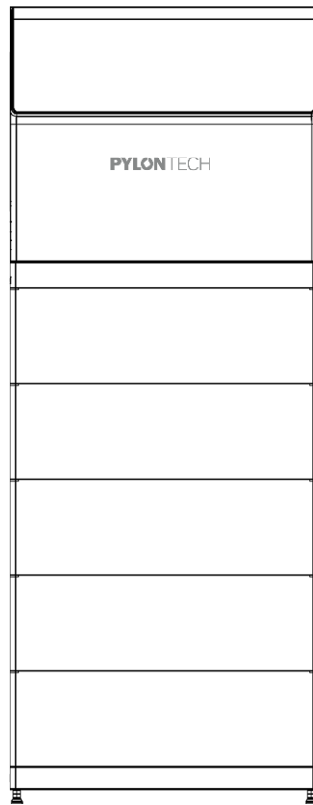

3.3.3 Installation Foundation Requirements

The support surface should have sufficient load-bearing capacity to support a minimum weight of 300 kg.

The system must be installed on a fixed and flat support surface. It is recommended that the system be installed on a cement surface.

3.4 System Installation



Danger: The system is a high voltage DC system, operated by qualified and authorized person only.

3.4.1 Mounting the Battery Base

Approach 1: When the system cannot be mounted with wall brackets, in order to ensure that the system does not fall over, the base must to be fixed to the support surface with 4 pcs M8×60 expansion bolts.

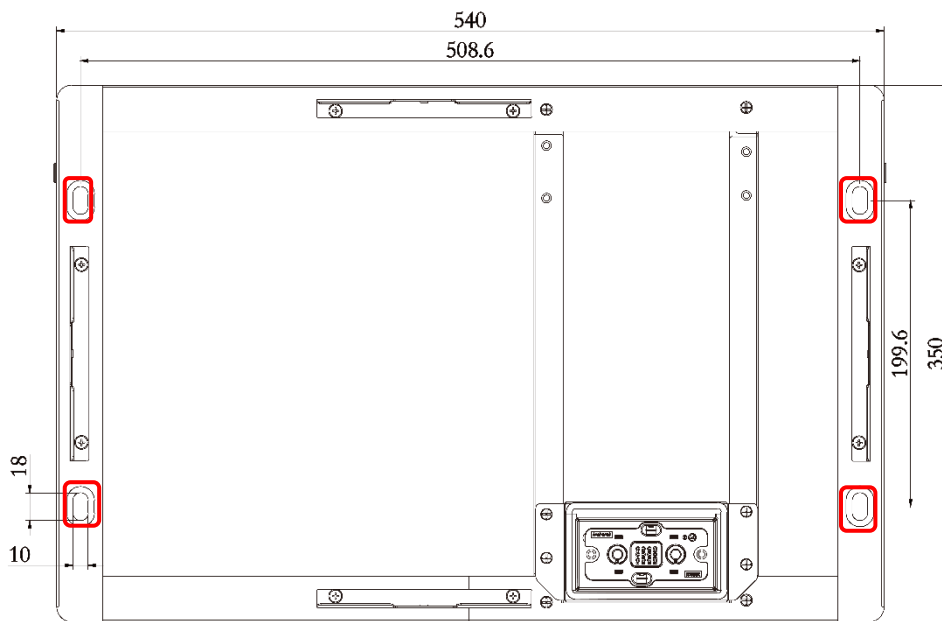

Battery rack base holes' (circled in red) bitmap (unit: mm)

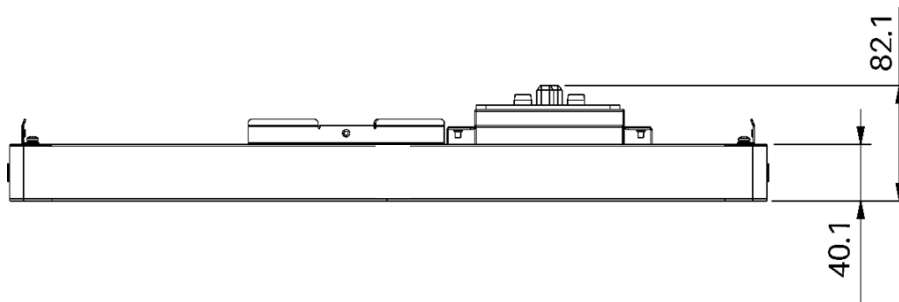

Battery rack base bitmap (unit: mm)

Approach 2: If the ground of installation area is uneven, install the base feet which can be adjusted at the four corners to ensure that the system is in a horizontal position with an additional leveling instrument.

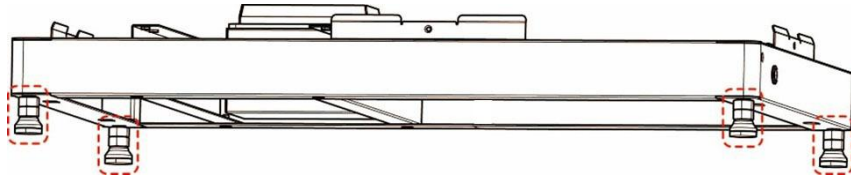

3.4.2 Installing the Battery Module onto the Base

WARNING

Warning: Single battery module is 39 kg. The battery module should be handled by at least 2 people if there're no handling tools.

1. Lift the two handles on the battery module as below, making sure the battery not tilting to one side.
2. Adjust to keep the connector of the battery (circled in red) align with the connector of the base (circled in red). Slowly put down the battery, fitting it properly onto the base. It is important to ensure that the module is installed vertically, to prevent misalignment of the connectors.
3. Continue to install the left battery modules one by one onto the existing battery.

NOTE: Maximum 7 battery modules are allowed to be installed in one system.

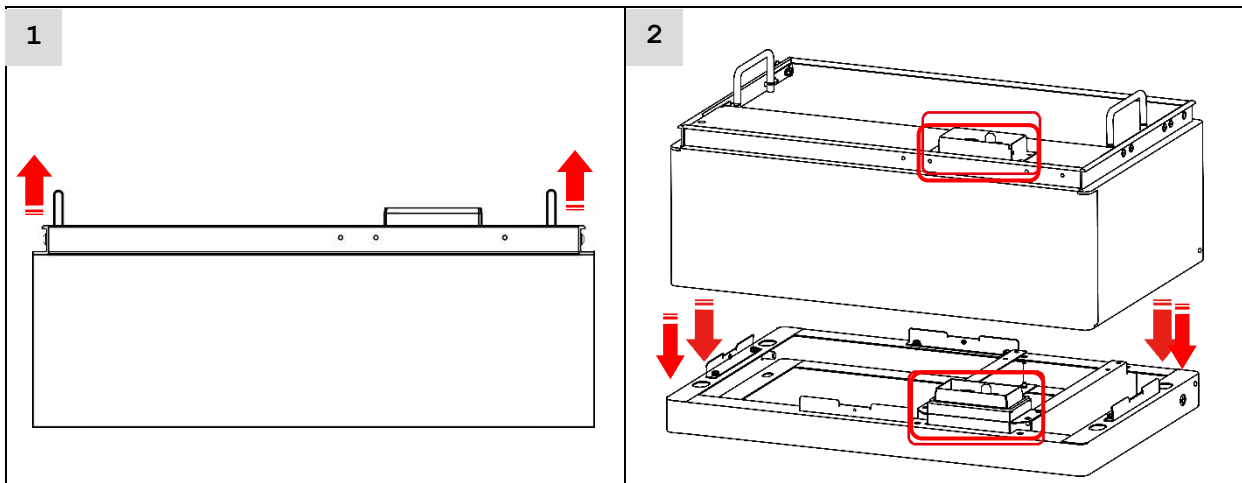

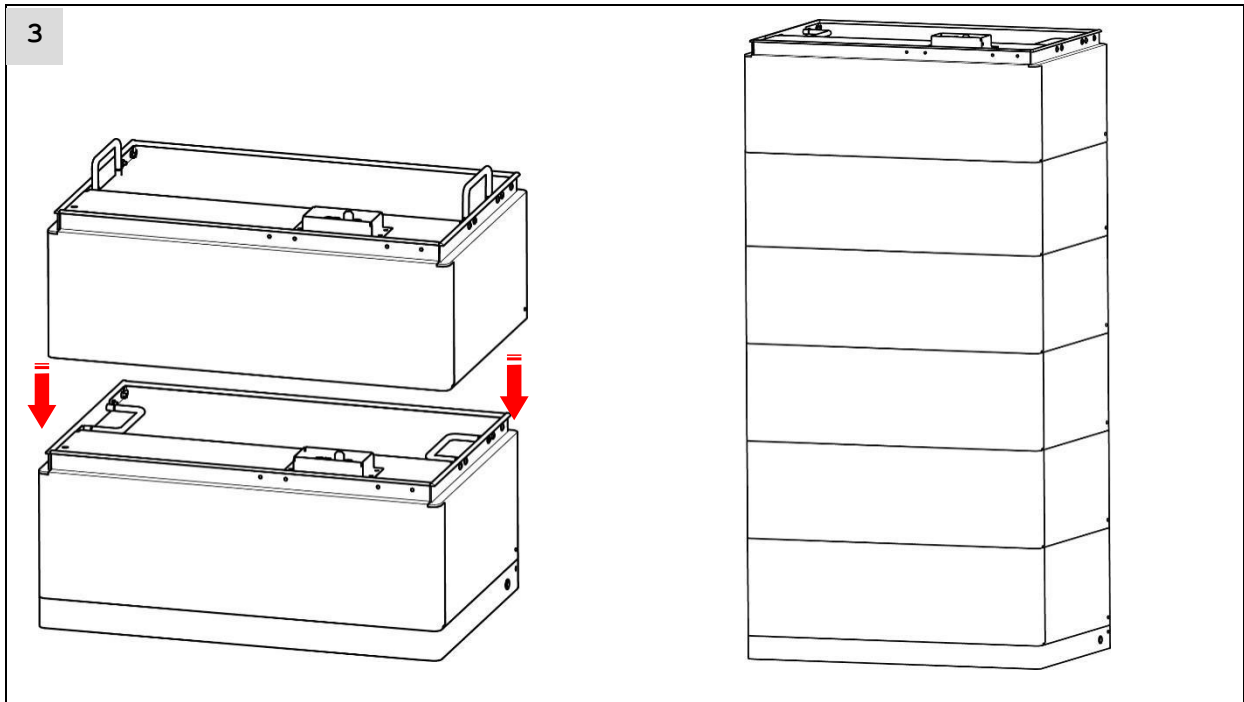

3.4.3 Installing the Power Controller onto the Battery Module

⚠ DANGER

Danger: When battery is connected together with the base, the internal socket still has high voltage DC power from serial connected battery modules.

1. Insert the 2 lifting handles into the holes on the left and right sides of the controller. Tighten the 2 lifting handles until they are immovable and the handles are securely connected.

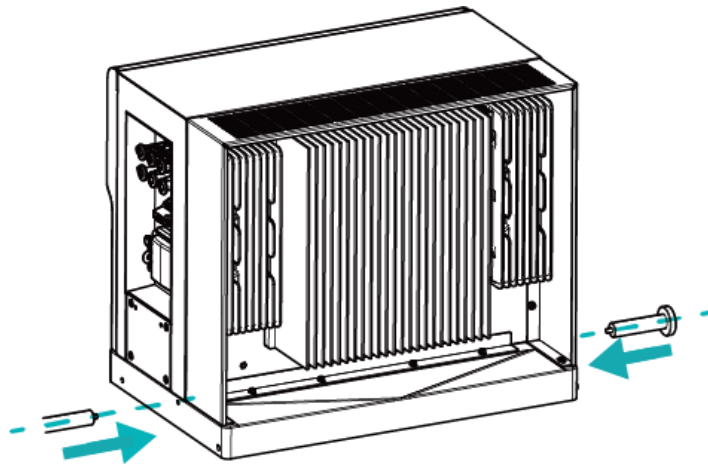

2. Place one hand on the top edge of the controller and one hand on the lift handle to slowly lift up the controller by 2 people.
3. Adjust to make the connector of the controller align with the connector of the battery module. Slowly put down the controller, fitting it properly onto the battery module.

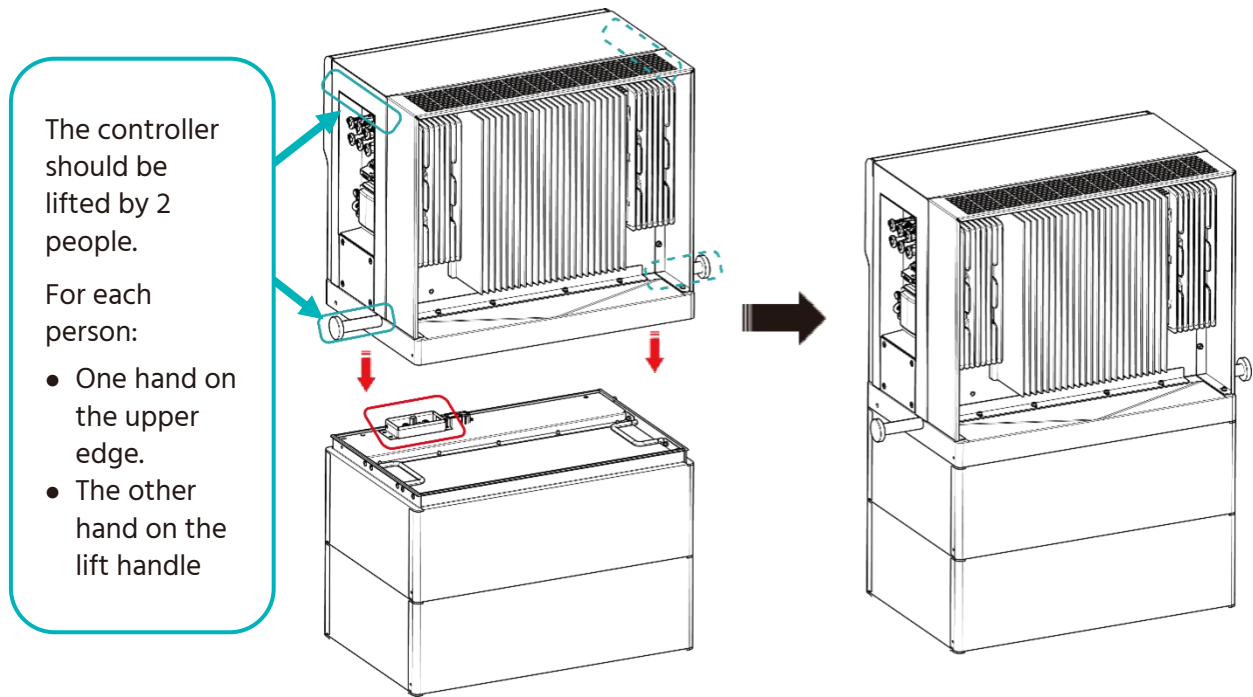

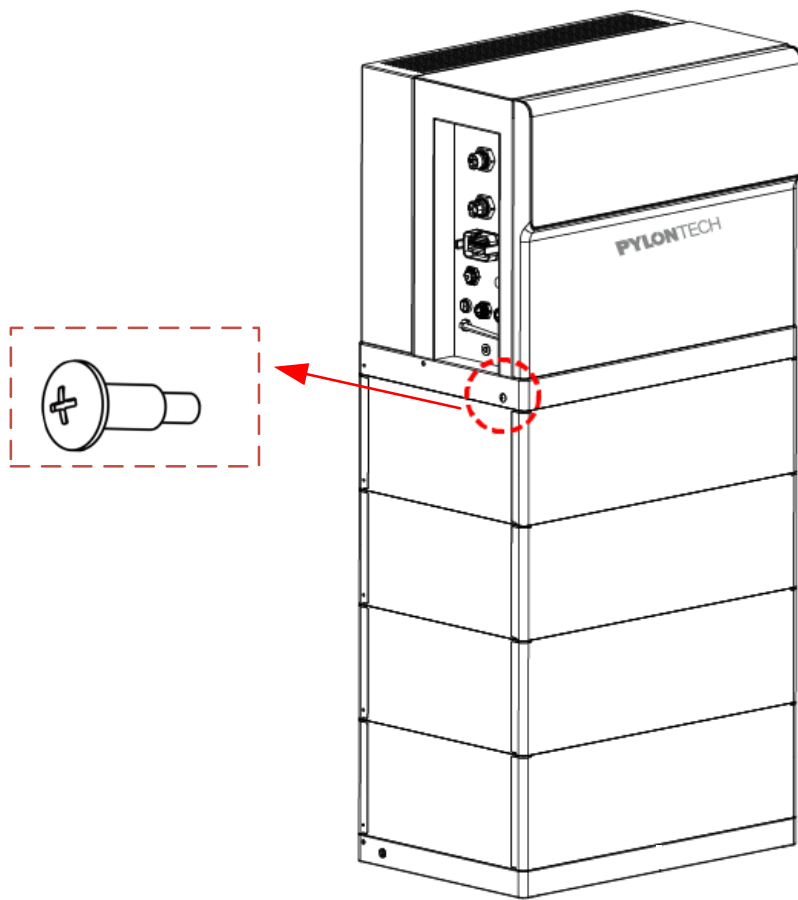

3.4.4 Installing the Metal Brackets for the System

There are 3 sizes of metal brackets in the package of the controller (6 pcs in total).

2pcs (for 1 module); 2pcs (for 2 modules); 2pcs (for 3 modules).

Fix these metal brackets at both back sides of the battery modules (see the figure below).

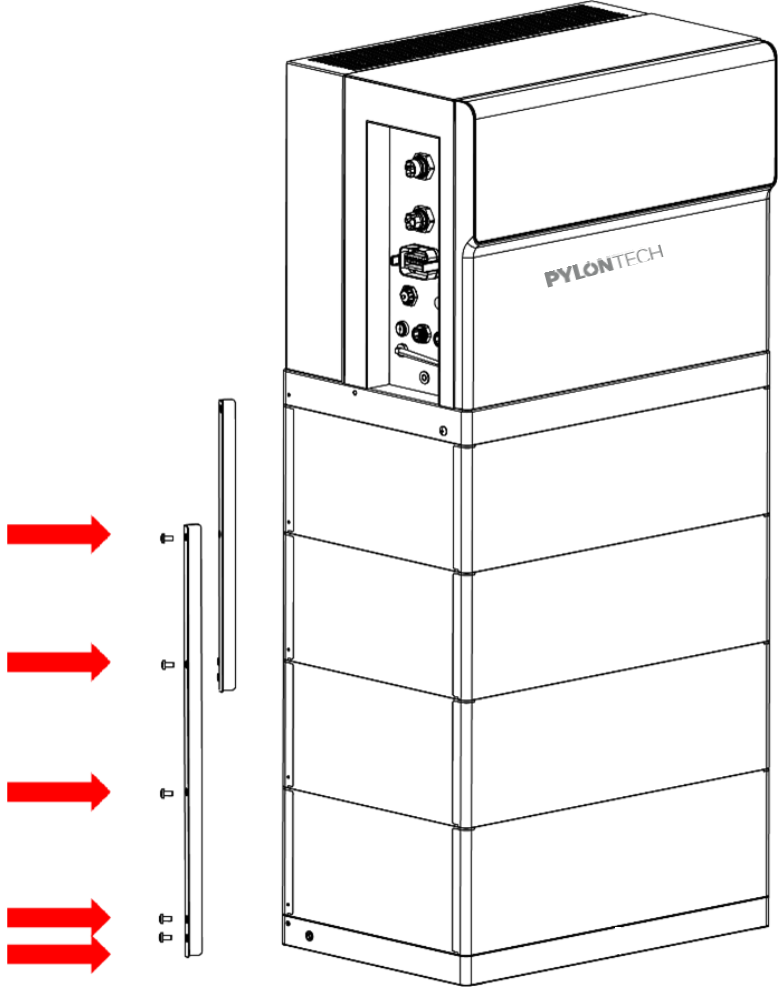

Please follow the illustrations below to install the metal brackets for your practical system.

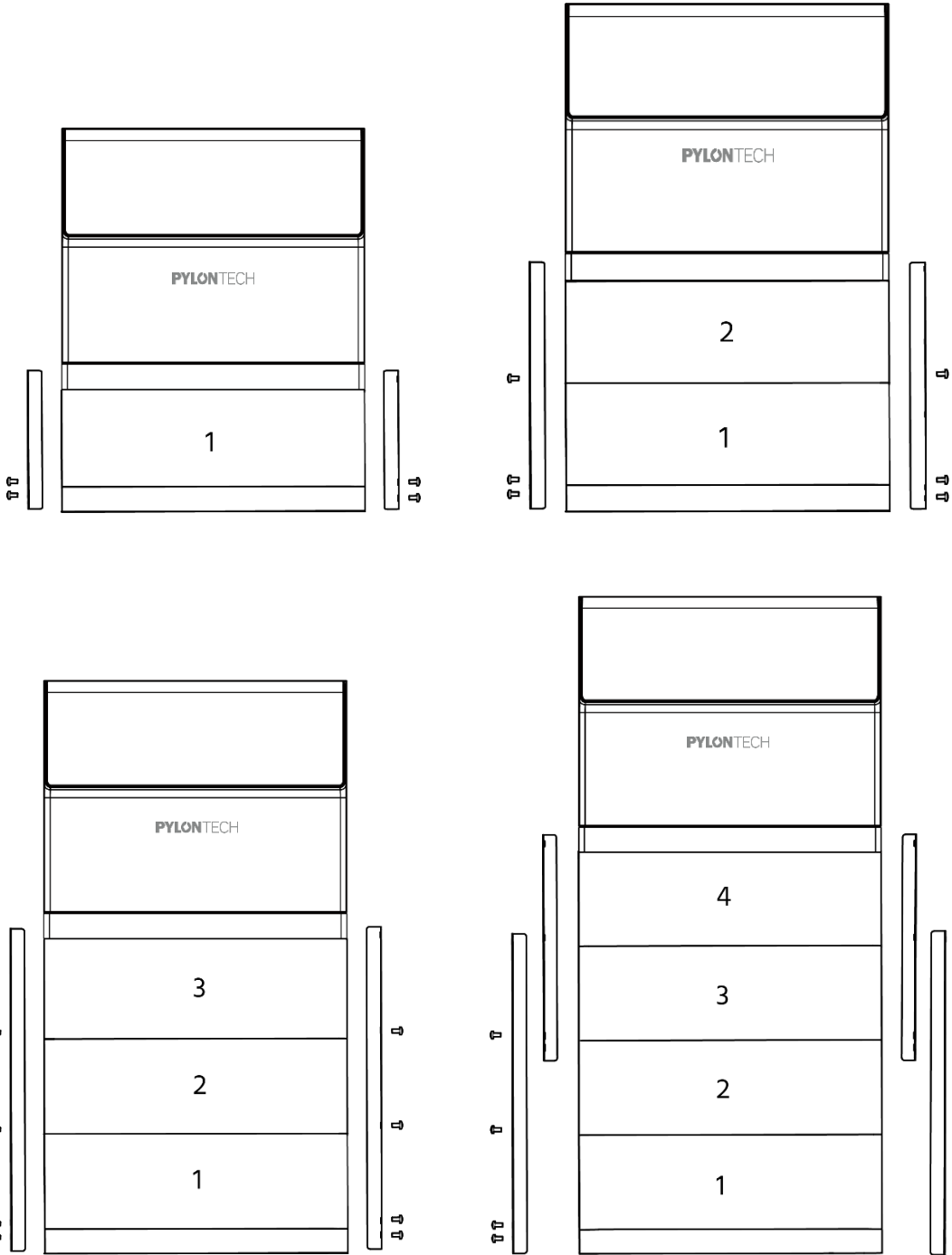

3.4.5 Installing the Anti-Toppling Brackets for the System

Force H3 system is equipped with two anti-toppling brackets as follows.

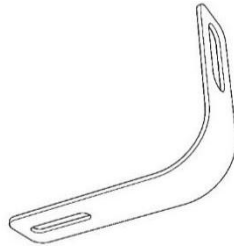

Such brackets act as an alternative of ground mounting of the battery system. Customers can choose either of the following methods for the system installation:

- Ground mounting with 4 x M8 expansion bolts to the support surface (see *Section 3.4.1 Mounting the Battery Base*).
- Bracket mounting with 2 x M8 expansion bolts to the wall (Battery system still needs to be placed on the support surface for supporting the overall weight.)

As long as the installation area meets the requirement of the installation site (see *Section 3.3 Selecting the Installation Sites*), in either case the installation stability is guaranteed.

The detailed installation process with such brackets are as follows:

1. Put the base along the wall and reserve 42-62 mm distance between back of the base and the wall.

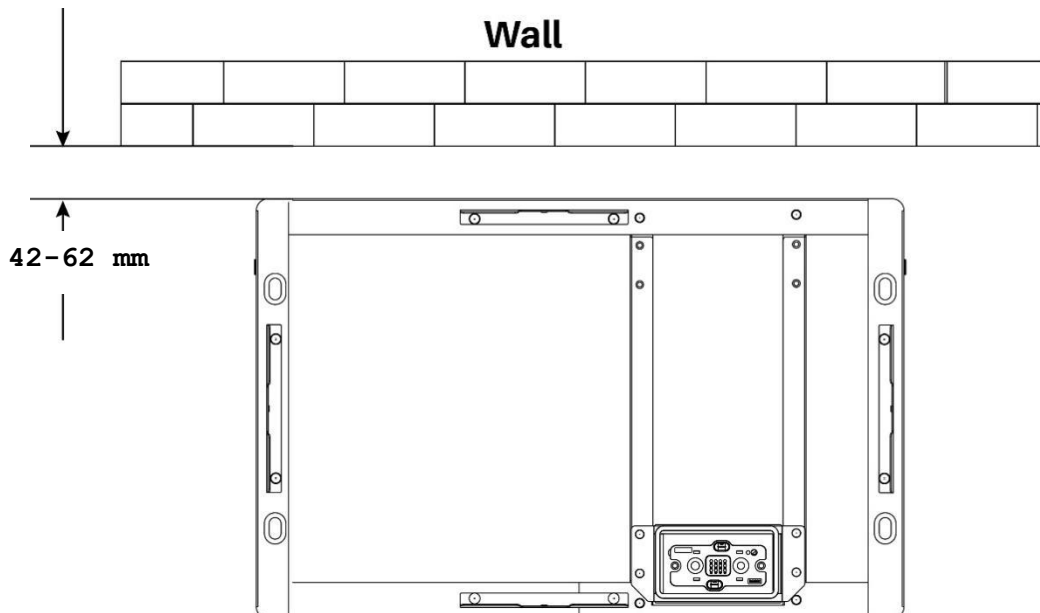

2. Follow the steps described above correctly to install all the battery modules, controller and brackets, seeing *Section 3.4.2 Installing the Battery Module onto the Base*, *3.4.3 Installing the Power Controller onto the Battery Module* and *3.4.4 Installing the Metal Brackets for the System*.

NOTE: When installing the metal brackets at the back side, always remain the two connecting points between brackets and controller unscrewed shown as below.

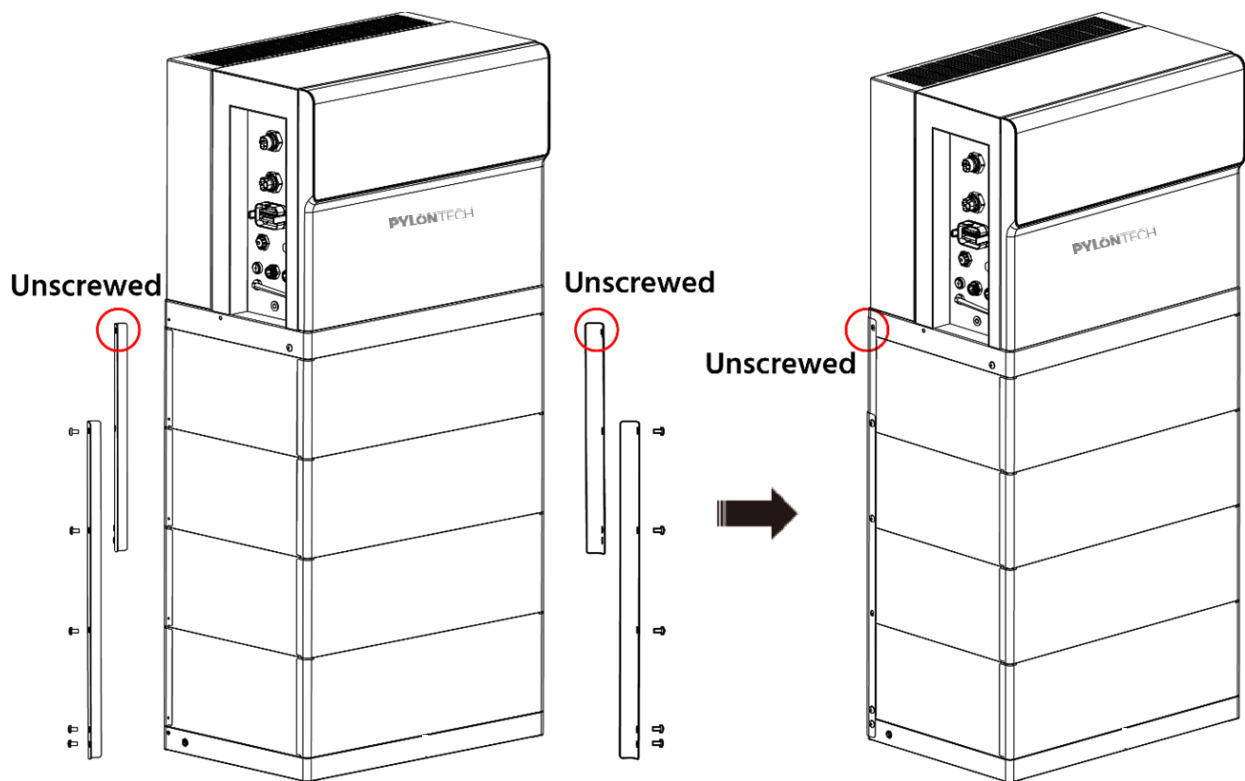

3. Follow the illustrations below, firstly fit the anti-toppling brackets on back sides of the controller, then use M4 screws to fix.

REMEMBER to fit the brackets on both sides of controller, same with following steps:

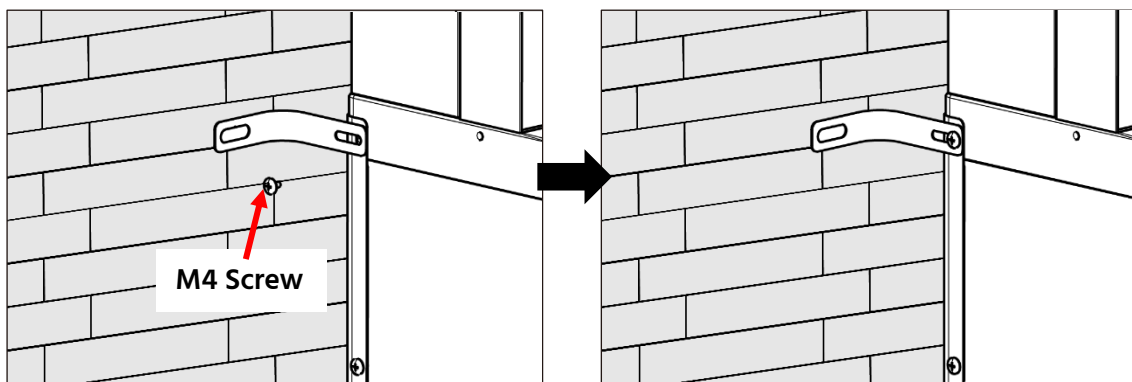

4. Mark the central points of the slotted holes at both sides on the wall.
5. Dismantle the brackets on both sides. Aligning the central points, drill two holes (≥ 60 mm depth) in the wall with a hammer drill, and clean the holes.

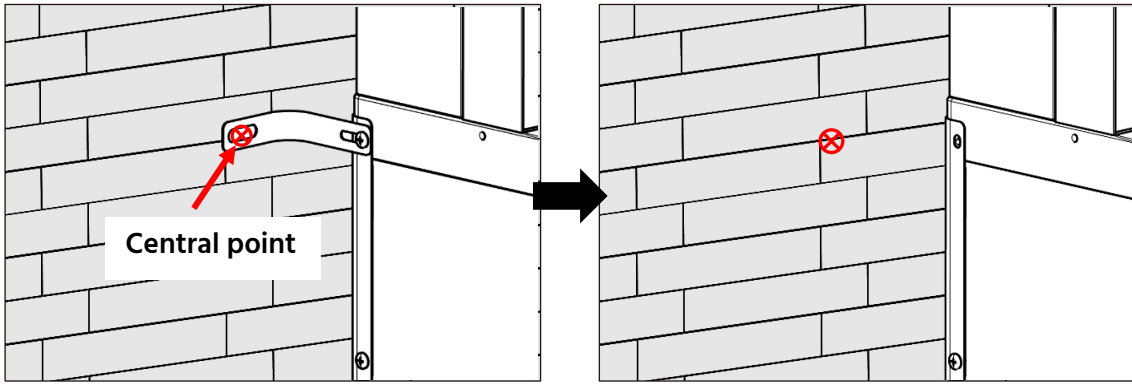

6. Embed the two M8 expansion bolts into the holes respectively.

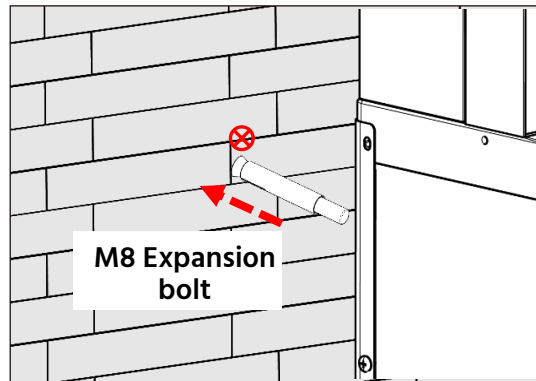

7. Fit the brackets across the M8 expansion bolts on both sides, then fix the brackets on the controller with M4 screws (tightening torque: 1.7~2.2 N·m).

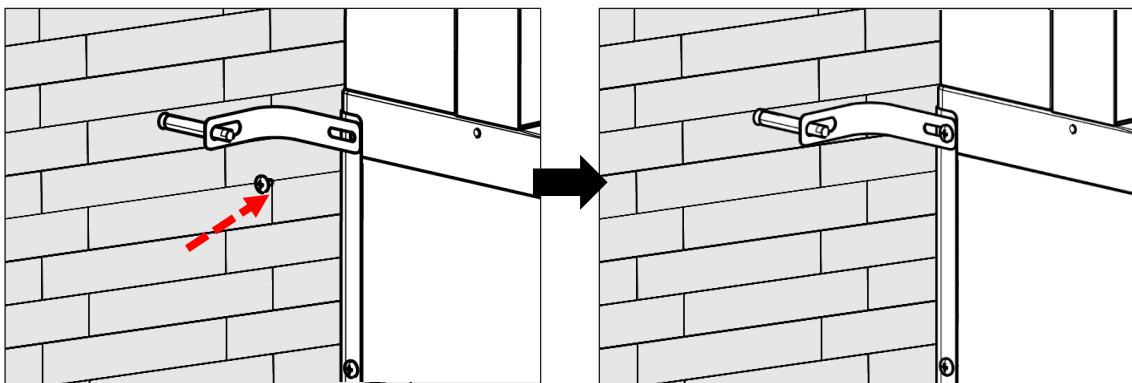

8. Fix the M8 nut (a) across the 8 mm flat gasket (c) and spring washer (b) with a torque of 12~13 N·m. Repeat this step for the other bracket.

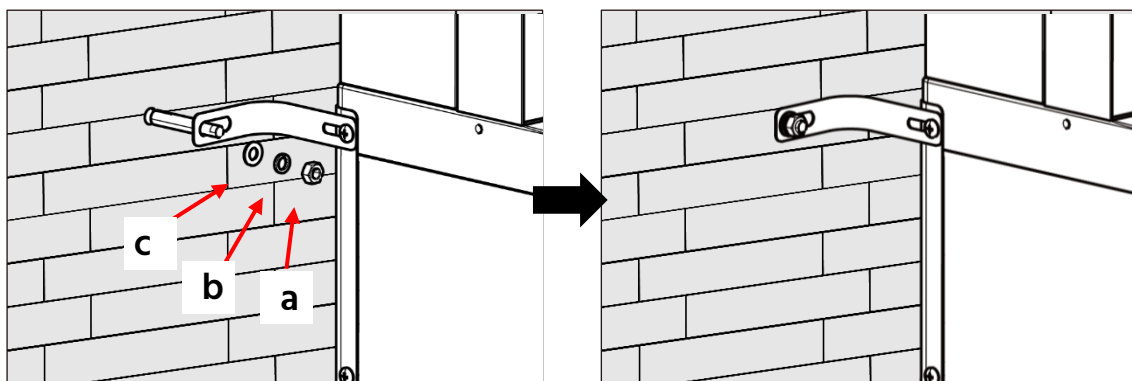

4 Cable Connection

4.1 Safety Instructions

- Measure the frequency and voltage of grid connection and make sure they follow the system's grid connection specifications.
- An external circuit-breaker on the AC side is strongly recommended (>>> see *Section 4.5.3 AC Switch Types*).
- Reliability of all ground connections must be tested and valid.
- Before commissioning, disconnect the FH3X and the circuit-breaker, and prevent accidental reconnection.

CAUTION

Caution: Wrong communication cables connection will cause the energy storage system failure.

4.2 Preparing Cables

Cable specification requirements

Item	Type	Conductor Cross-section	Cable Outer Diameter
AC cable	Outdoor copper cable	<ul style="list-style-type: none"> • 3.6K: 10 mm² • 5K: 10 mm² • 6K: 10 mm² • 8K: 10~16 mm² 	13~17.5 mm
BACK-UP cable	Outdoor copper cable	<ul style="list-style-type: none"> • 3.6K: 10 mm² • 5K: 10 mm² • 6K: 10 mm² • 8K: 10 mm² 	13~17.5 mm
DC cable	Standard outdoor PV cable PV1-F Model recommended	4~6 mm ²	5~8 mm
Communication cable		0.2 mm ²	4.5~6.5 mm
Grounding cable	Outdoor copper cable	<ul style="list-style-type: none"> • 3.6K: 4~6 mm² • 5K: 10 mm² • 6K: 10 mm² • 8K: 10~16 mm² 	-
External cable to heat pump		0.5 mm ²	4.5~7.0 mm

4.3 System Diagram

4.3.1 Electrical Wiring Diagram

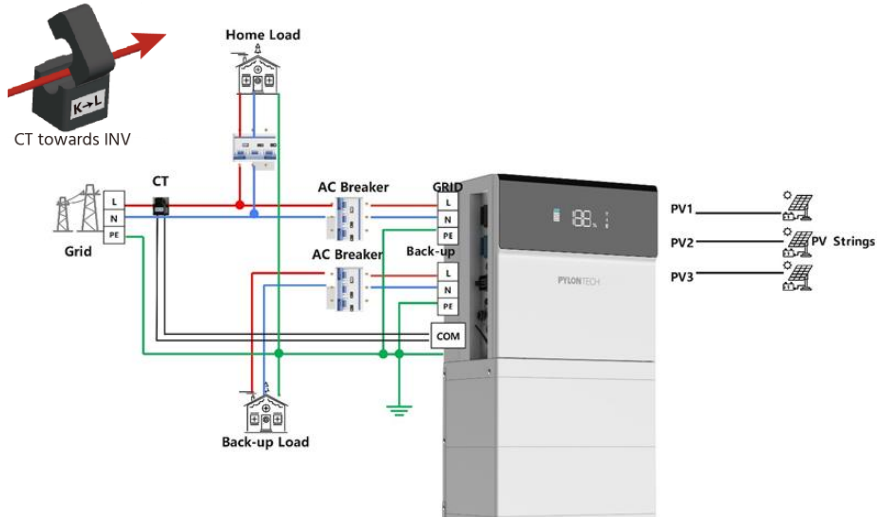

4.3.2 Standard Wiring Diagram

For countries without specific wiring requirements, please complete the installation according to this wiring diagram; otherwise BACK-UP function will not work. Please select enable of the N_PE relay in the app.

Note: Ensure reliable grounding for both the grid and the backup.

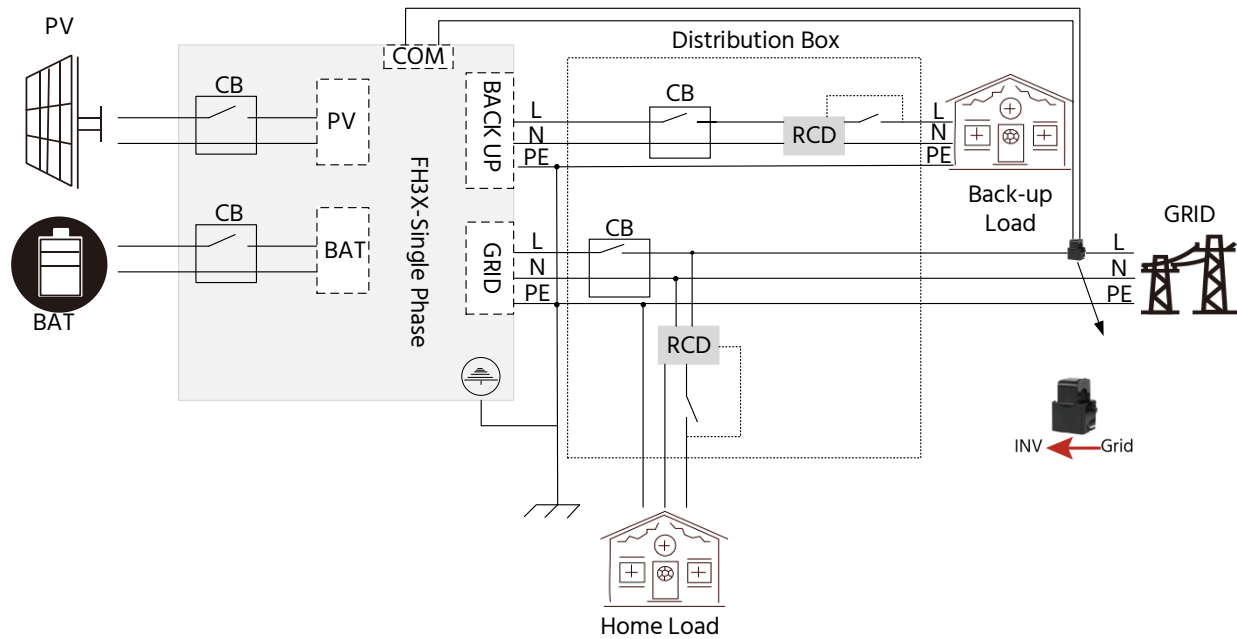

4.3.3 Australia Wiring Diagram

For Australia, New Zealand and South Africa, where the Neutral bar and PE cable of grid and back-up are connected together in the distribution box, please complete the installation according to this wiring diagram; otherwise BACK-UP function will not work. Please select disable of the N_PE relay in the app.

When the inverter safety is applied under AS/NZS 4777, the MEN (Multiple Earthed Neutral) function is available. The external wiring must be carried out by a licensed electrician in accordance with local regulations

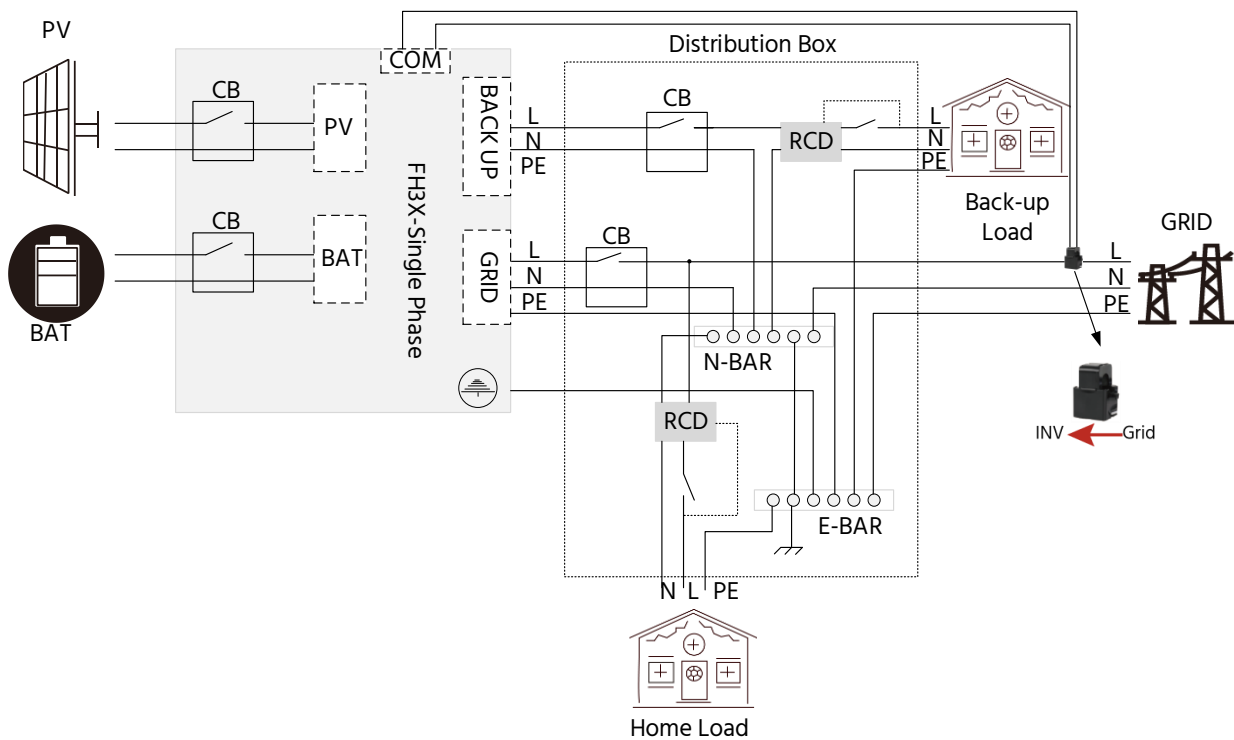

4.4 Grounding Connection

Procedure

1. Prepare the cable and OT/DT terminal.

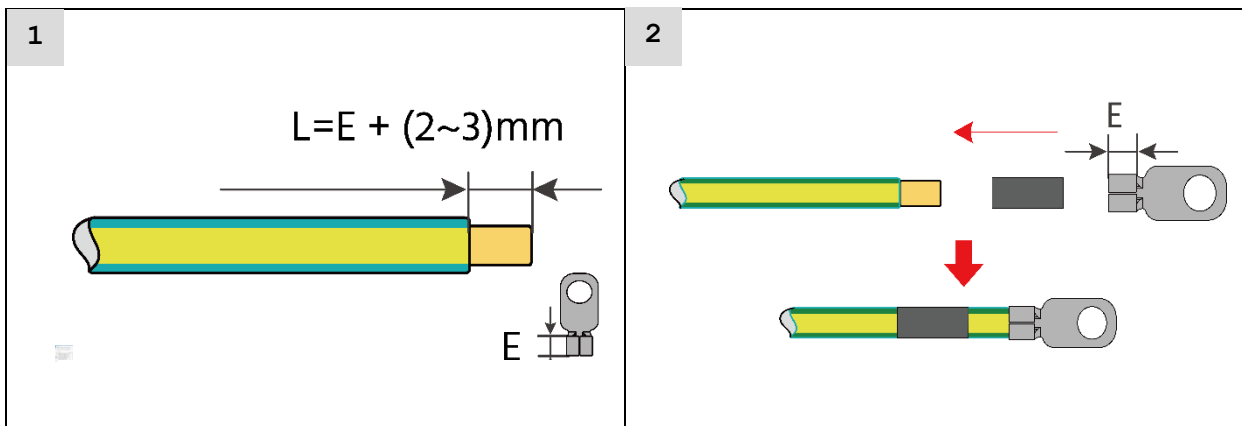

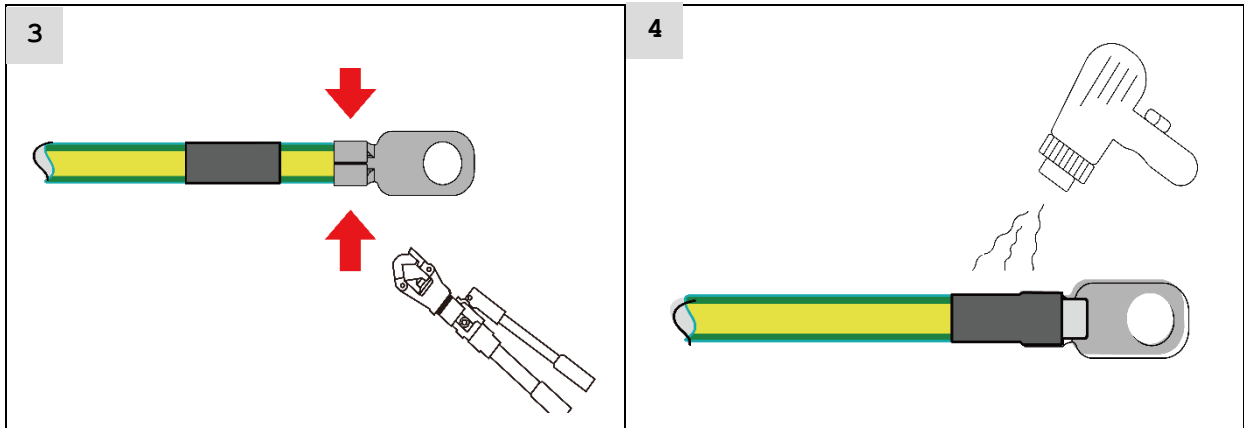

NOTE: After being crimped, the OT terminal must wrap the wires completely, and the wires must contact the OT terminal closely. When using a heat gun, protect the device from being scorched.

2. Use the ground screw (see in the packing list >>> see *Section 3.1 Checking Before the Installation*) and fix the grounding wire to the chassis grounding point with a screwdriver

⚠ WARNING

Warning: The system has 3 grounding points as follows. Any one of these grounding points can be used for grounding.

The Grounding cable must meet the following requirements:

- For 3.6K: 4~6 mm²(the same area as AC Cable)
- For 5K and 6K: ≥ 10 mm²
- For 8K: 10~16 mm²(the same area as AC Cable)

The cable shall be copper with yellow-green color.

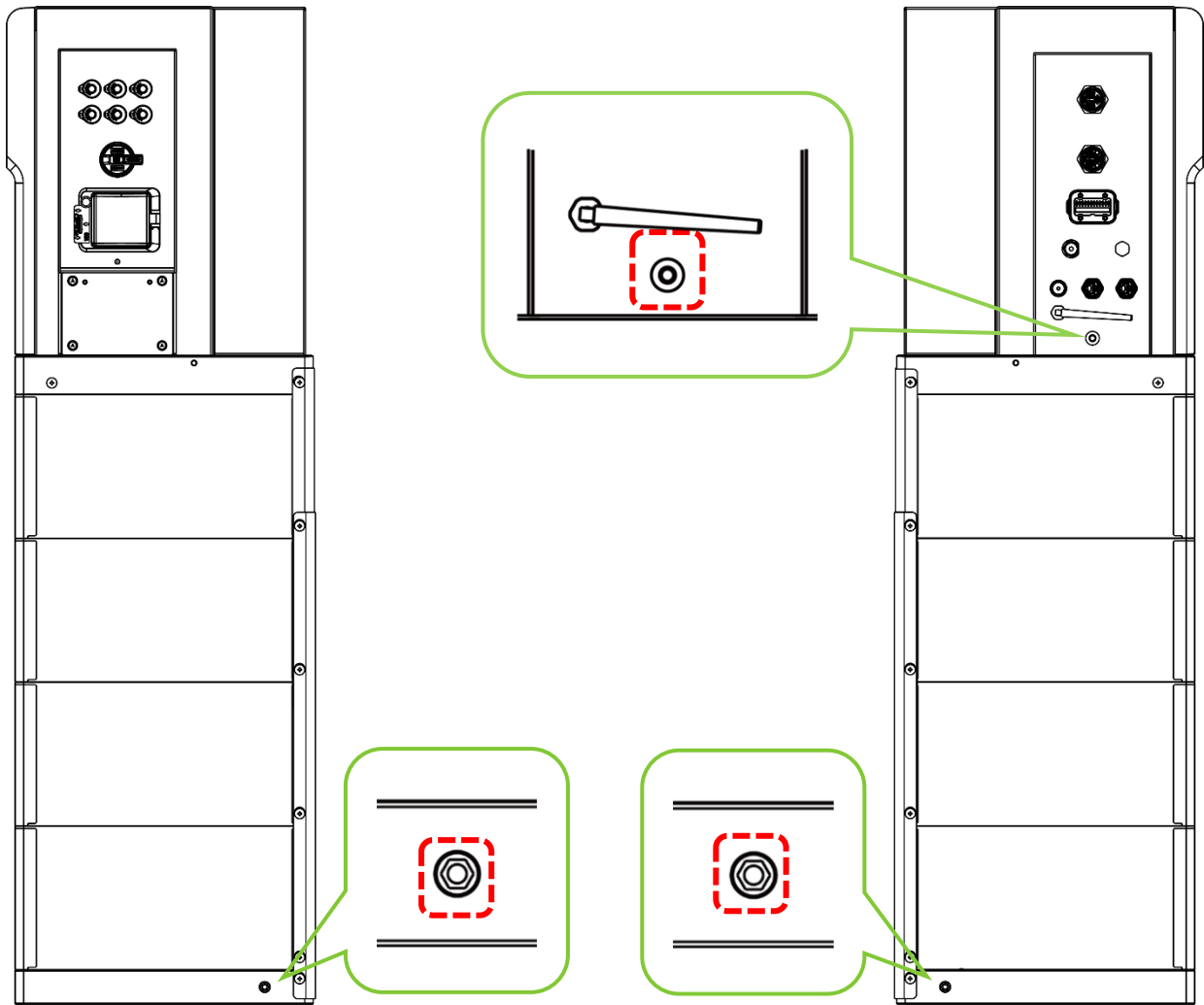

3. Apply paint to the grounding point to ensure corrosion resistance.
4. Verify that the ground connection meets local requirements. Ensure that the metal brackets and anti-toppling brackets are securely fastened to the system (screws are fully tightened).

4.5 AC Connector Assembly and Connection

There are two AC terminals on the power controller with similar assembly steps.

- The AC GRID terminal: connect to the grid.
- BACK-UP terminal: connect to the critical load circuit.

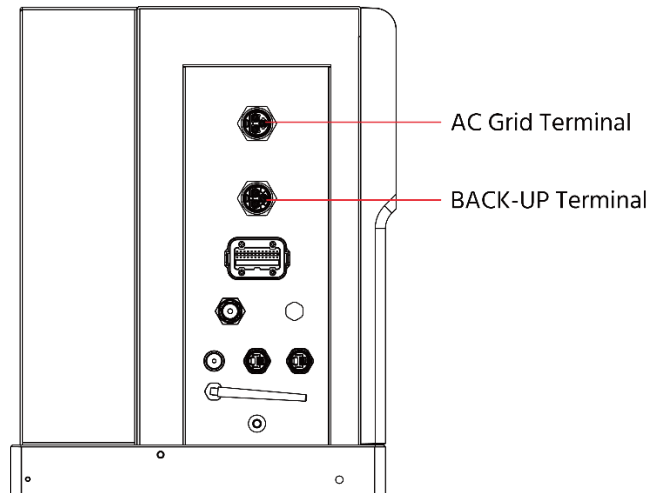

4.5.1 AC Connector Type A Assembly and Connection

4.5.1.1 AC Connector Assembly

Procedure

1. Insert the following tool into the hole of the cable gland and remove the terminal plug.



2. Unscrew the swivel nut from the connector.

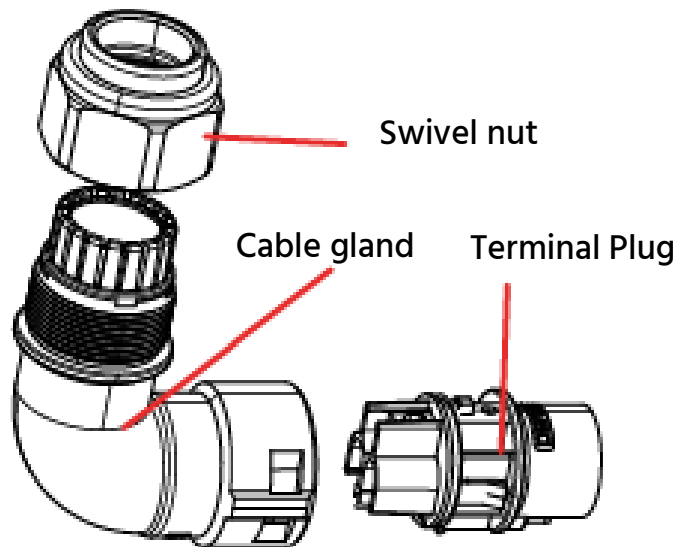

3. Thread the AC cable through the cable gland.
4. Strip 85 mm or 87 mm of the cable jacket and 10 mm of the wire insulation.

NOTE: The color of the cable cores in the figure is for reference only, and cables or cable cores selected must meet local standards. When using a multi-core multi-strand copper wire cable, connect the AC wire head to the cord end terminal (hand-tight). In case of single-strand copper wire, skip this step.

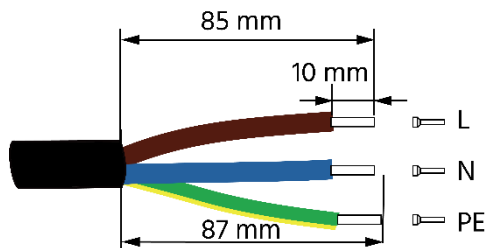

NOTE:

When crimping terminals for three wires, the front side needs to be pre-bent to allow the wires to pass through the connector.

5. Loosen the screws in the terminal plug with the L-shaped screwdriver.

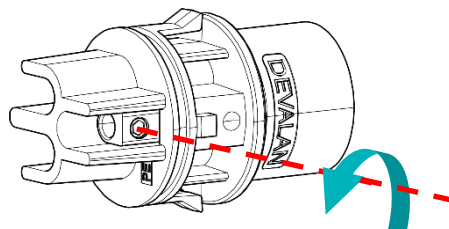

6. Plug the wires to the terminal plug according to the labels on the plug and tighten the screws in the terminal plug with the L-shaped screwdriver. Ensure that the wires are securely in place by slightly pulling outwards.

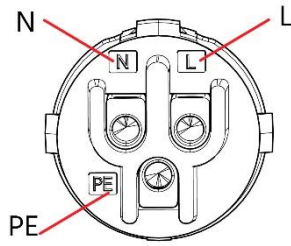

NOTICE

Notice: Observe the assignment. Do not connect any phase line to the "PE" terminal or the PE wire to the "N" terminal. Otherwise, unrecoverable damage to the system may follow.

7. Push the terminal plug into the cable gland until there is an audible click.
8. Tighten the swivel nut to the housing with appropriate torque.

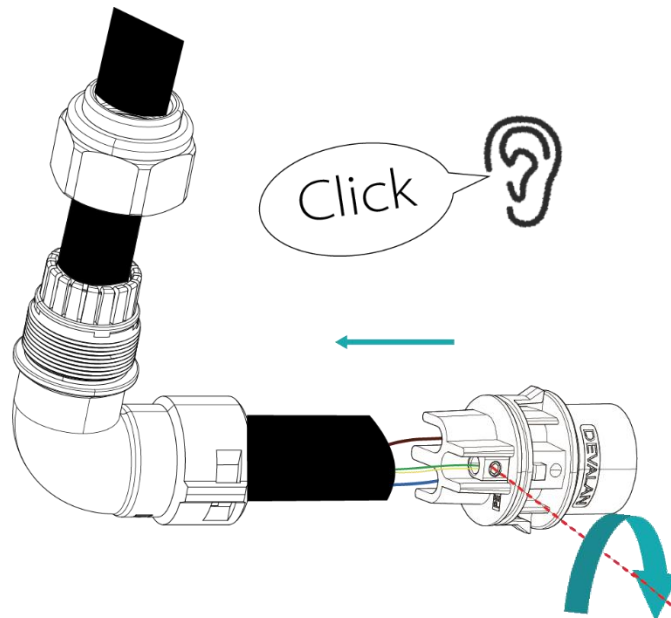

4.5.1.2 AC Connector Connection

Procedure

1. Insert the following tool or a small screwdriver into the waterproof lid to remove it from the AC terminal.



2. Insert the connector into the AC terminal until there is an audible sound.

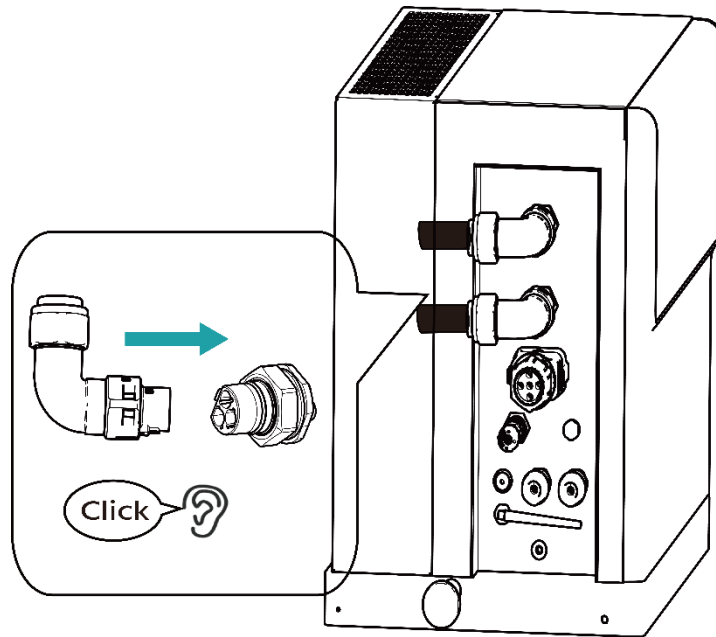

4.5.2 AC Connector Type B Assembly and Connection

4.5.2.1 AC Connector Assembly

Procedure

1. Insert the following tool into the hole of the cable gland and remove the terminal plug.



2. Unscrew the swivel nut from the connector.

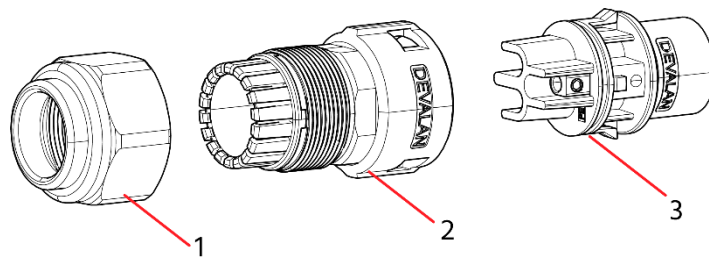

1. Swivel nut 2. Cable gland 3. Terminal plug

3. Thread the AC cable through the cable gland.
4. Strip 20 mm ~ 30 mm of the cable jacket and 12 mm of the wire insulation.

NOTE: The color of the cable cores in the figure is for reference only, and cables or cable cores selected must meet local standards. When using a multi-core multi-strand copper wire cable, connect the AC wire head to the cord end terminal (hand-tight). In case of single-strand copper wire, skip this step.

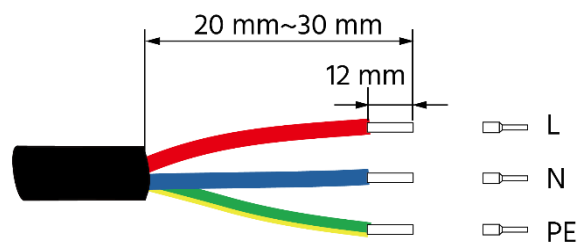

5. Loosen the screws in the terminal plug with the L-shaped screwdriver.

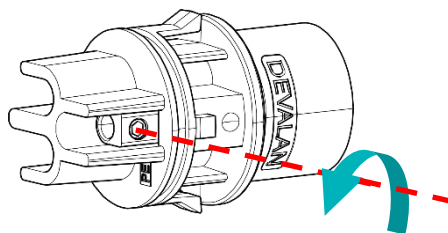

6. Plug the wires to the terminal plug according to the labels on the plug and tighten the screws in the terminal plug with the L-shaped screwdriver. Ensure that the wires are securely in place

by slightly pulling outwards.

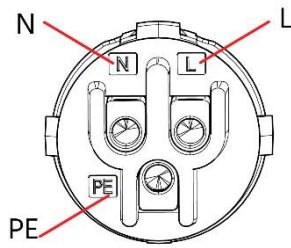

NOTICE

Notice: Observe the assignment. Do not connect any phase line to the “PE” terminal or the PE wire to the “N” terminal. Otherwise, unrecoverable damage to the system may follow.

7. Push the terminal plug into the cable gland until there is an audible click.
8. Tighten the swivel nut to the housing with appropriate torque.

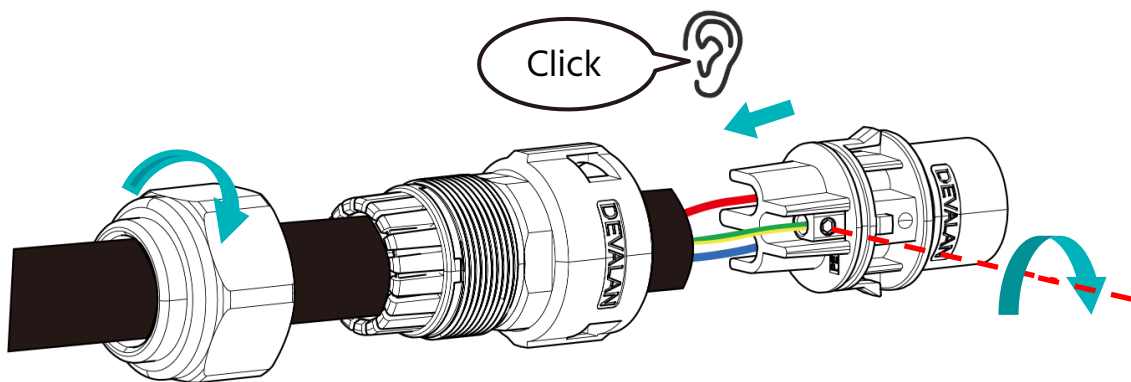

4.5.2.2 AC Connector Connection

Procedure

1. Insert the following tool or a small screwdriver into the waterproof lid to remove it from the AC terminal.



2. Insert the connector into the AC terminal until there is an audible sound.

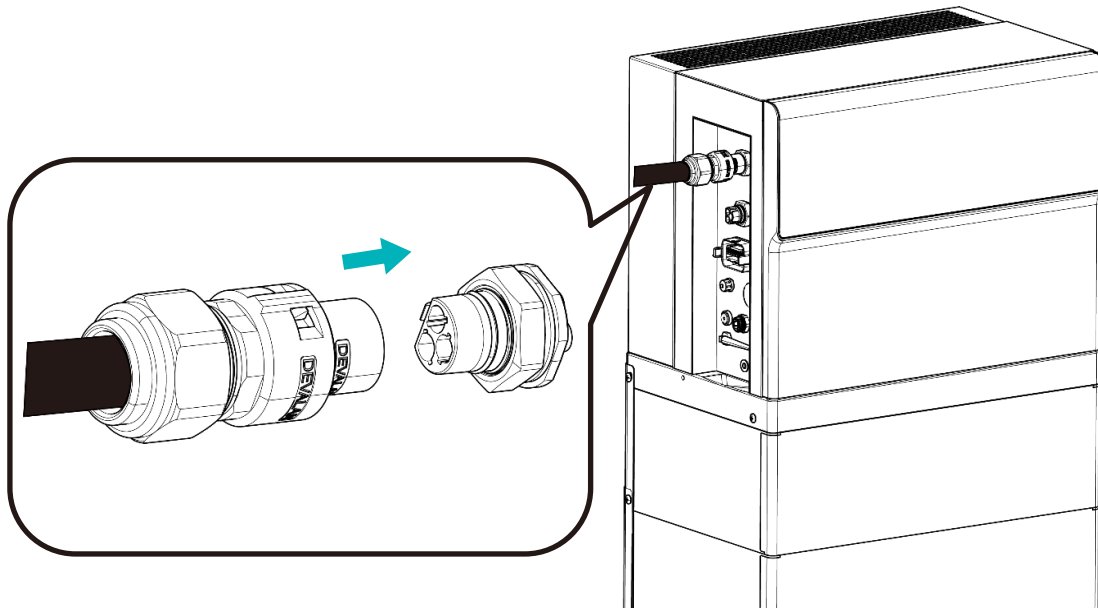

4.5.3 AC Switch Types

Please install an individual 2-stage miniature circuit breaker according to the following specifications.

System Model	AC Terminal Type	Maximum Current (A)	AC Breaker Rated Current (A)
FH3X-3.6K-HY-1P	Grid	23.5	50/230V AC
	Back-up	15.7	
FH3X-5K-HY-1P	Grid	32.6	
	Back-up	21.7	
FH3X-6K-HY-1P	Grid	39.1	63/230V AC
	Back-up	26.1	
FH3X-8K-HY-1P	Grid	52.2	
	Back-up	34.8	

Recommended circuit breaker specifications

Breaker	Rated Parameter	Number of Pole Pairs	I _{cc}	I _{cp}	Breaking Characteristic
1	50A / 230V AC	2	10KA	6KA	Type C
2	63A / 230V AC	2	10KA	6KA	

Recommended leakage current protection device

In the system installation, it is recommended to add leakage current protection device at the grid access and load output, generally 30mA (type B) RCD can meet the requirement.

4.5.4 EPS Load Information

Ensure that the start power does not exceed the EPS peak power of the inverter.

Type of Load	Maximum Single Load Capacity	
Resistive load	Rated power	Dryer, water dispenser, disinfection cabinet, toaster, oven, incandescent lamp, garment steamer, curling iron, computer, home phone, stereo system, monitor, television, projector, heater, bathroom heater, fan, small charger, LED light
Inductive load	0.3*Rated power	Fixed-frequency air conditioners, fixed-frequency refrigerators
	0.5*Rated power	Vacuum cleaner, washing machine, inverter air conditioner, water pump, garage door opener, treadmill, electric lawn mower, inverter refrigerator, electric cloth dryer, electric drill, microwave oven

Note: Refer to the nominal start power of the equipment for the actual start power.

Recommended load on the back-up side

Suitable	Not Suitable
Refrigerators and freezers	Critical Medical Devices
Fans	Air conditioners & heaters
Small, occasional use, plug-in appliances e.g., microwaves, kettles, toasters	Ovens & cooktops
TVs, radios, telephones	Home theatres and Projectors
Computers, tablets, routers	Hot water systems
Mobile phone or small-device chargers	Spas, saunas, pool pumps

Household tank water pumps	Battery chargers & corded Power tools
Low-energy LED or CCFL lighting	Incandescent or high-power lighting

4.6 PV Connector Assembly and Connection

4.6.1 PV Connector Assembly

NOTES:

- All PV modules of the connected strings must have the same orientation and tilt angle.
- Before commissioning and connecting the PV arrays, the PV switch MUST be open.
- It is mandatory to use the DC connectors within package for the connection of PV arrays.
- The polarity of the PV arrays MUST be compatible to the DC connectors of power controller.
- The DC input voltage and DC input current of the PV array MUST never exceed the maximum input allowance of the power controller.
- Each PV string needs to be grounded.

Procedure

1. Strip off the insulation from each DC cable.

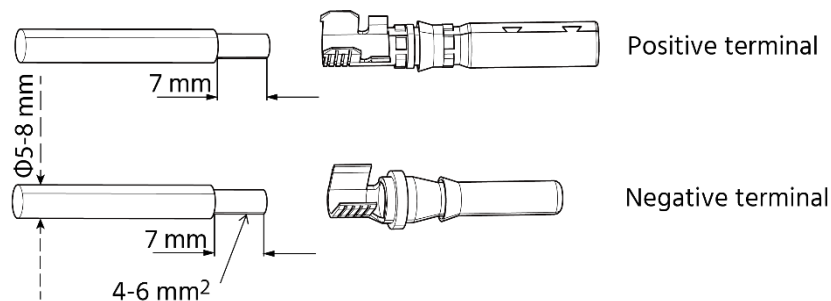

2. Assemble the cable ends with the crimping plier.

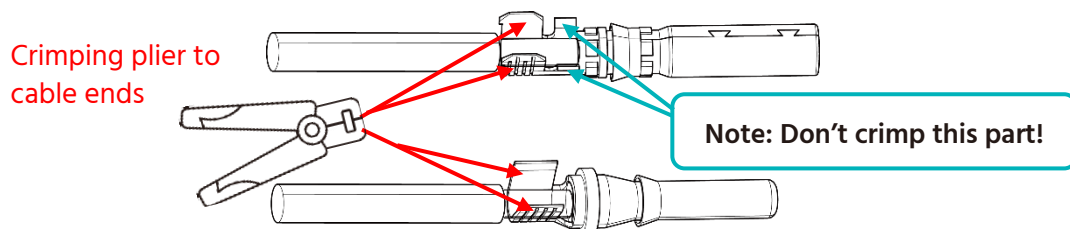

3. Thread the cable through cable gland and insert the crimp contact into the insulator until it snaps into place. Ensure that the cables are securely in place by slightly pulling outwards. Tighten the cable gland and insulator (tightening torque 2.6-2.9 N·m).

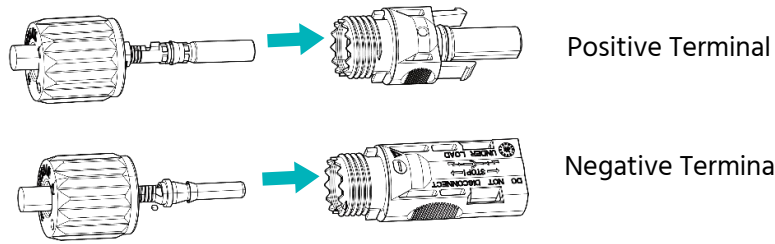

NOTE: Please check for polarity correctness. If the PV polarity is reversed, the system will be in a fault or alarm state and will not operate normally.

4.6.2 PV Connector Connection

1. Check the polarities of the PV strings. And check the open-circuit voltage is less than power controller input limit 600V.

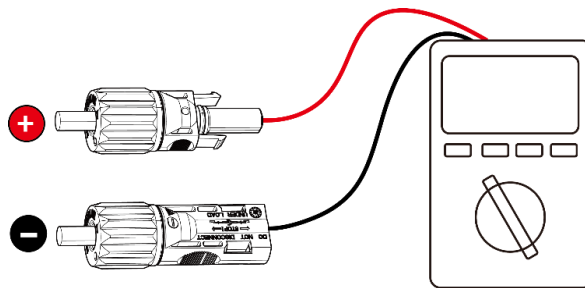

2. Remove the waterproof caps from PV terminals.

NOTE: If there is an unused terminal, please seal it with the cap.

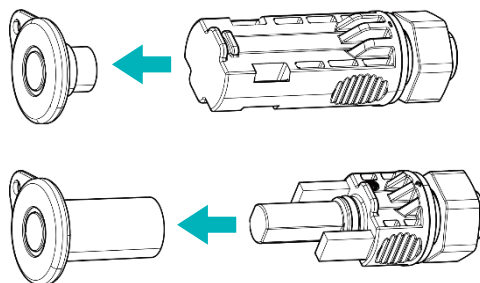

3. Insert the connectors into the terminal until there is an audible click.

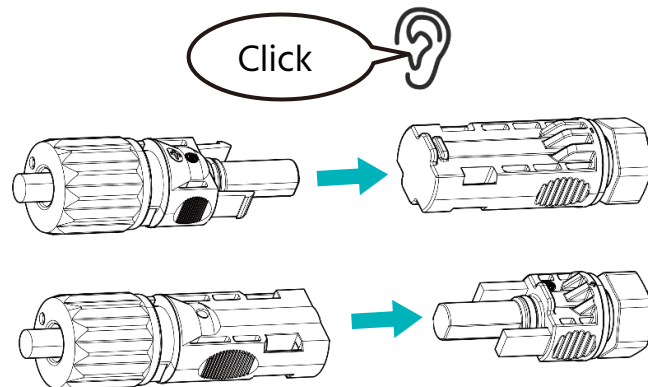

NOTE: The PV terminal can be removed by the following PV Terminal Removal Tool (see in the packing list >>> see *Section 3.1 Checking Before the Installation*)



4.7 EPO Connection

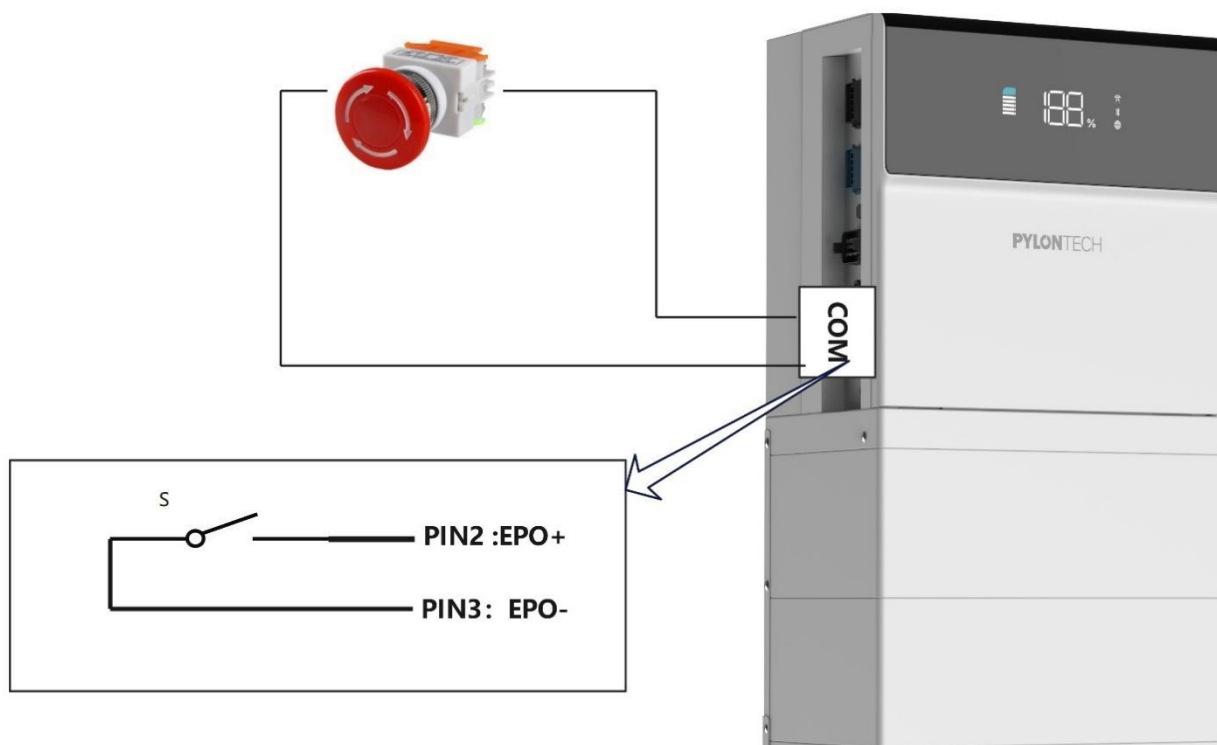

(PIN2 and PIN3 in the COM communication port are EPO function port pins. Connect PIN2 and PIN3 externally to a normally closed switch for short circuiting)

EPO (Emergency Power Off) function is a special feature of FH3X products, it can be used to switch off the inverter's full power through the external switch button, for safety operation in emergency situations.

This function is not enabled by default, if customers need to use it, they can enable EPO on the APP. When EPO is enabled, a normally closed switch must be connected to short EPO+ and EPO- signals, in case of emergency, the customer will open this normally closed switch to disconnect EPO+/EPO- signals, and the inverter will quickly cut off all the power components and stop working when it receives the disconnecting signal.

NOTES:

- When PV and Grid are not available and only battery power is supplied, the whole system will power down and shut down when the EPO switch is disconnected.
- When the EPO enable is on, the system will not work if the EPO+/EPO- signals are not shorted.

4.8 Heat Pump Connection

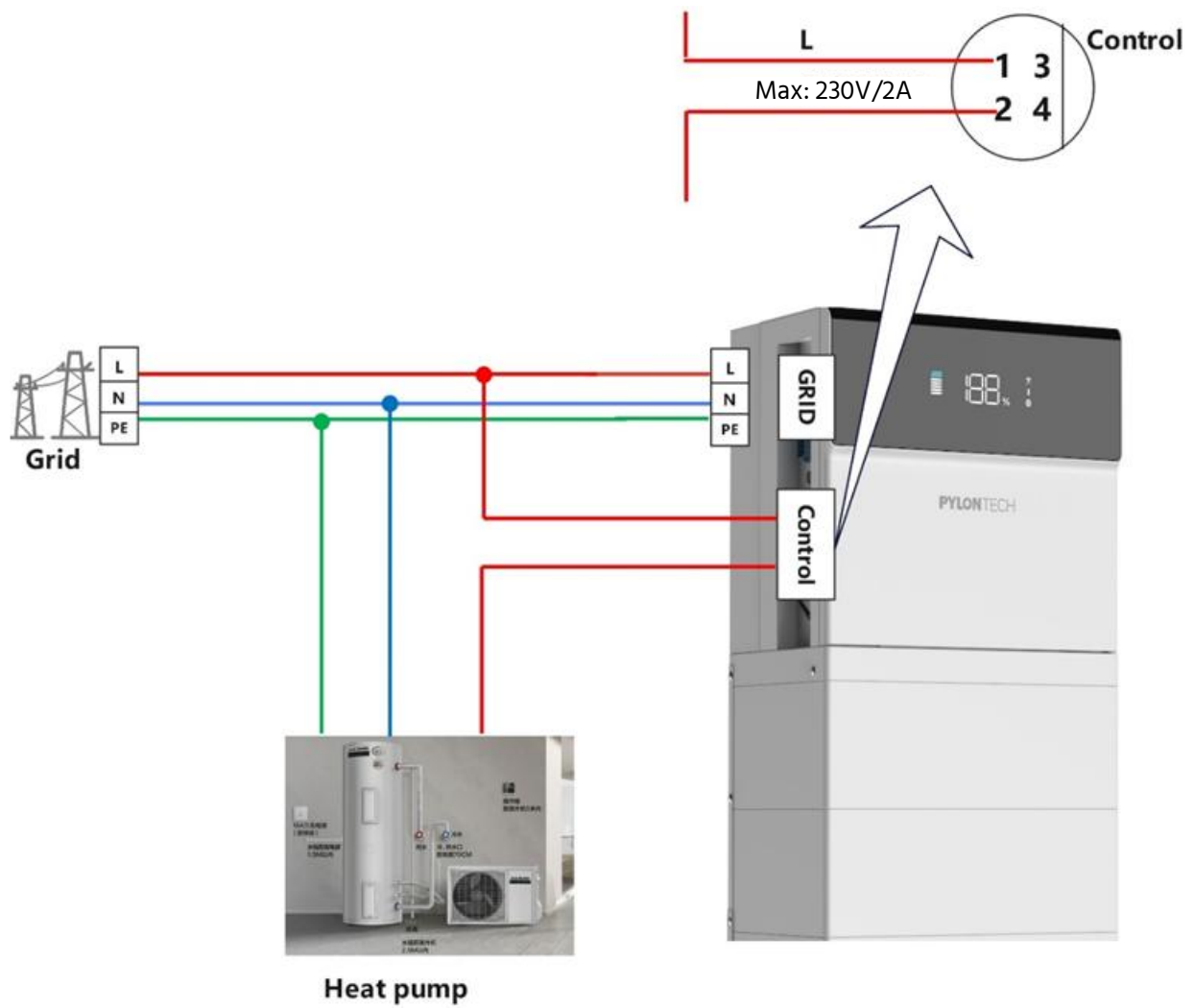

Users can use the heat pump shortcut button on the app to switch on and off the heat pump in their home.

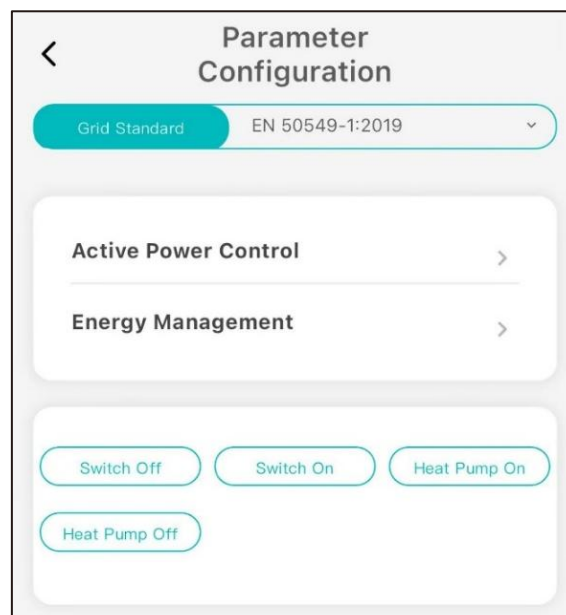

Heat Pump Signal Cable:

PIN1	PUMP+	Control heat pump start-up
PIN2	PUMP-	
PIN3	Outrelay+	Control EPS switchover
PIN4	Outrelay-	

4.9 CT Connection

How to connect CT only to the Multi-function terminal (without a meter)

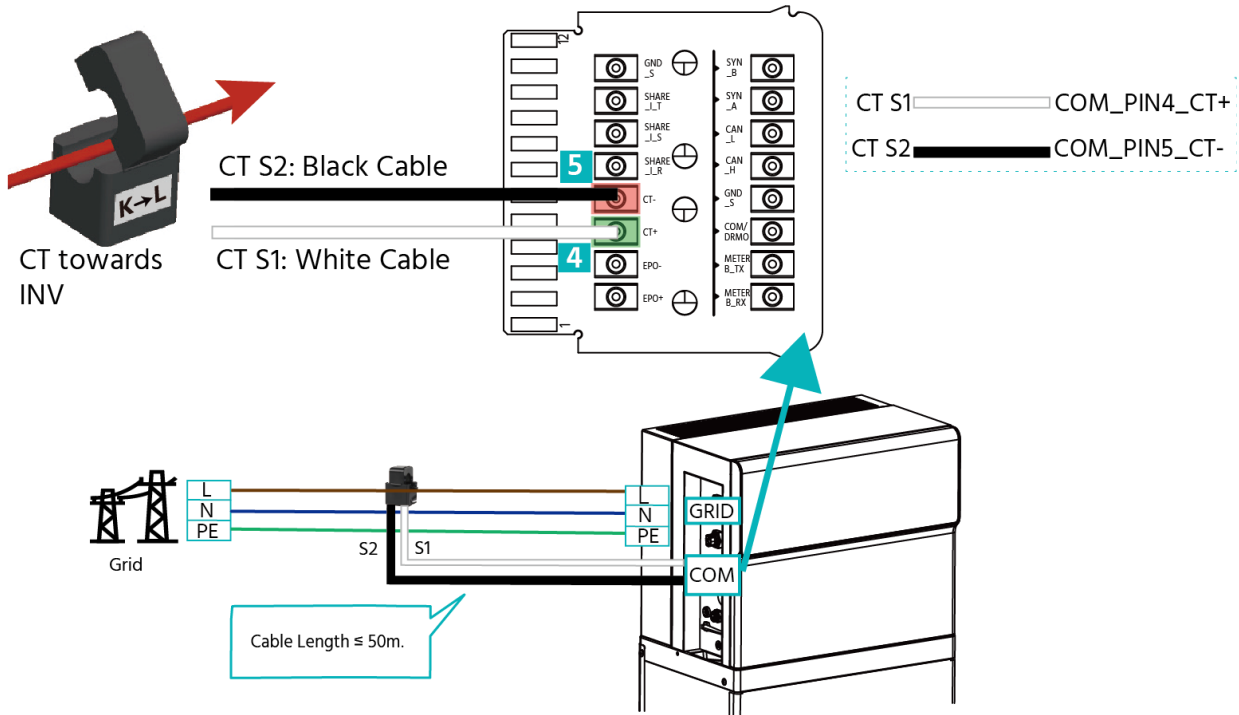

How to connect Meter to the Multi-function terminal (CT need to connect to the Meter)

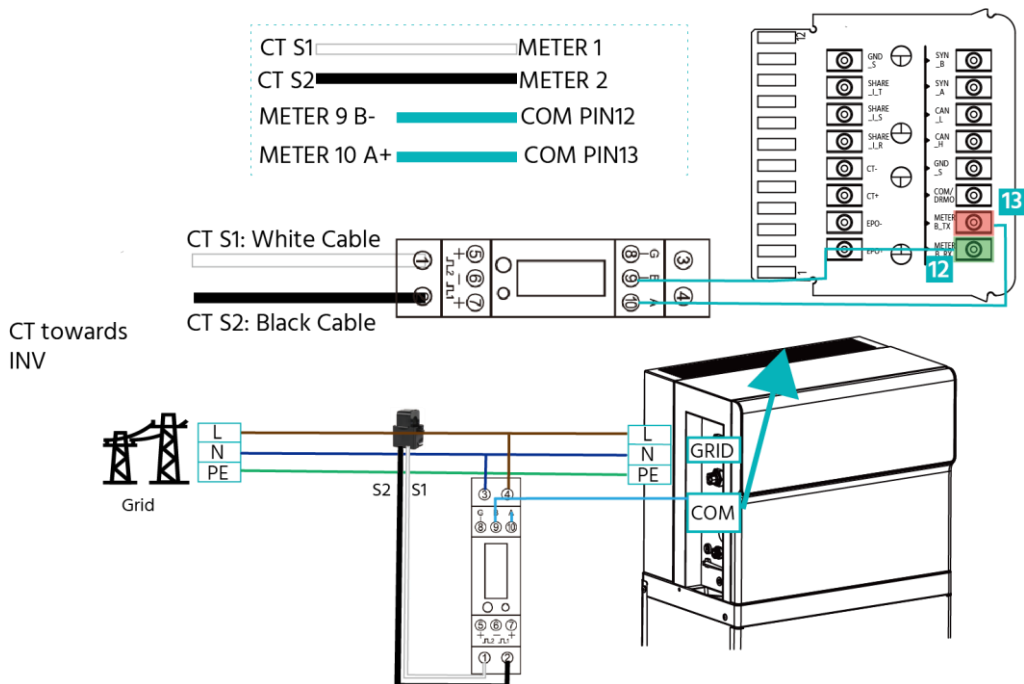

 NOTE:

- The maximum distance between CT and system is 50m.
- The color of the cable cores in the figure is for reference only, and cables or cable cores selected must meet local standards.
- Meter-3 connected to N-cable, meter-4 connected to L-cable; Please make sure meter connection is correct. Reverse connection may cause contact hazards.

4.10 DRM (Only DRM0 is Available)

In Australia and New Zealand, the inverter supports the demand response modes as specified in the standard AS/NZS 4777.

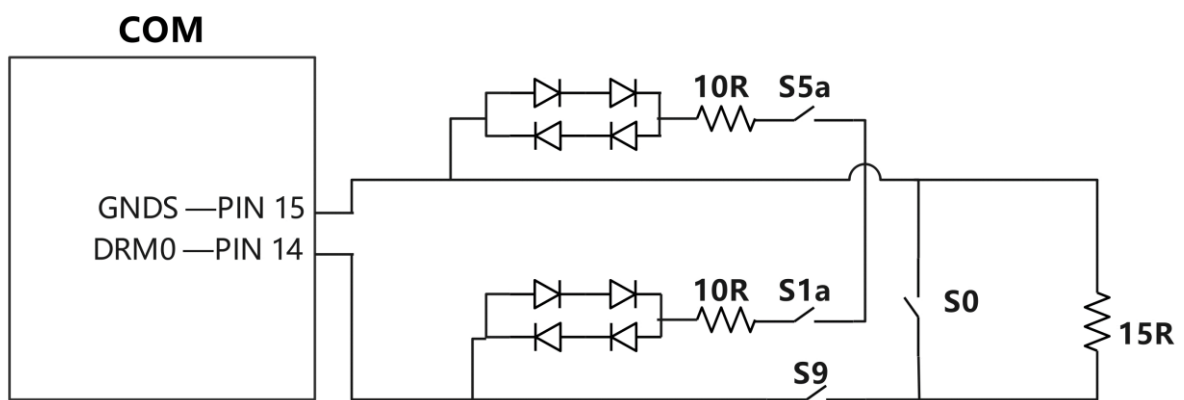

Function	Interface	Definition
DRM 0	Communication terminals pin 14 DRM0, pin 15 GNDS	By closing S9 and closing S0, the inverter disconnects the AC output; Closing S9 and disconnecting S0, the inverter resumes grid connection

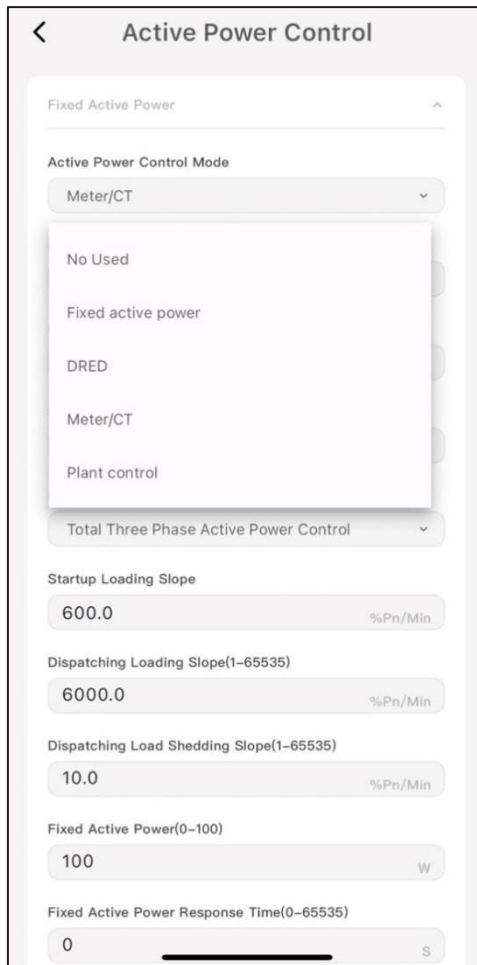

When DRM enable is turned on, connect the DRED (Demand Response Enabling Device) to the DRM0 interface on the inverter communication terminal to control DRM0.

4.11 Communication Connector Assembly and Connection

4.11.1 Communication Connector Assembly

1. Unscrew the swivel nut from the COM connector.
2. Press on the upper and lower parts as shown in the following figure to take out the terminal plug.

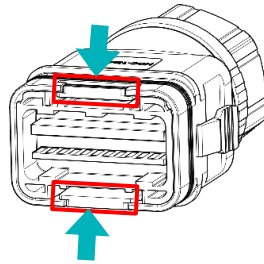

3. Remove the sealing rubber gasket and take out the rubber plugs from it.
4. Thread the cable through the swivel nut.
5. Insert the cable into the hole and get it stuck in the sealing rubber gasket.
6. Thread the cable of appropriate length through housing.

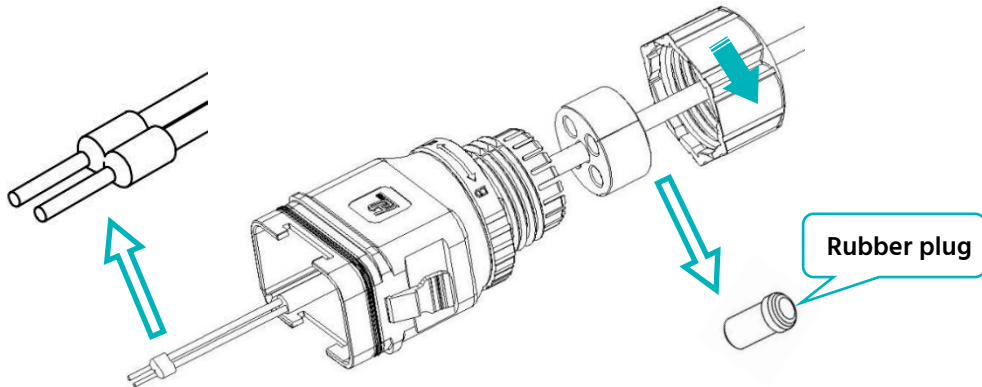

7. Strip the cable jacket and wire insulation according to the following dimensions.

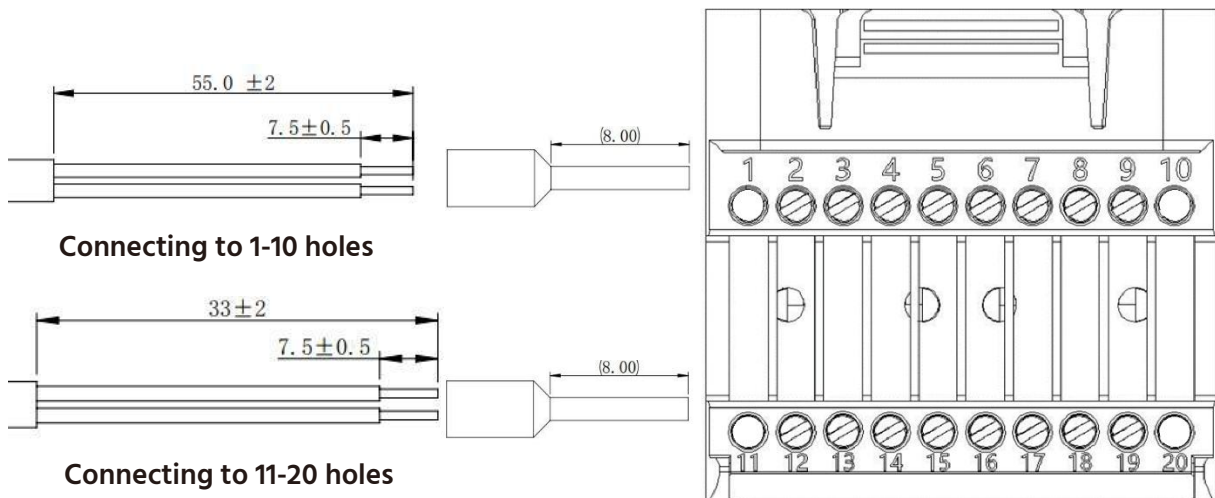

8. Fix all the wires to the terminal plug according to the following pin definition figure and tighten to a torque of 1.2+/-0.1 N·m with a slotted screwdriver. Ensure that the wires are securely in place by slightly pulling outwards.

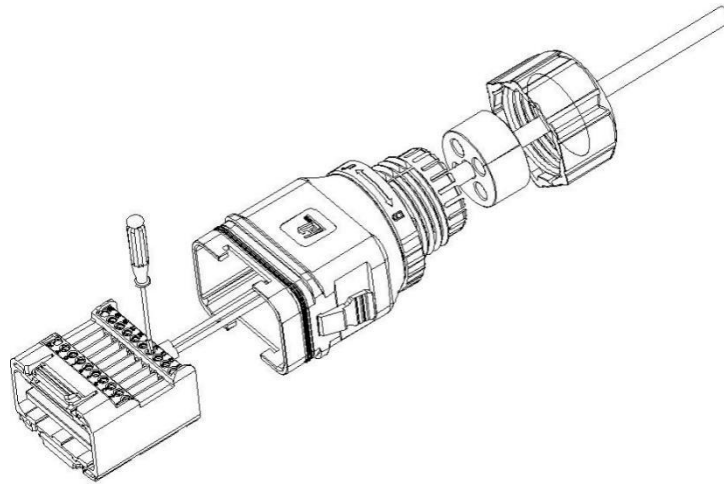

Pin definition

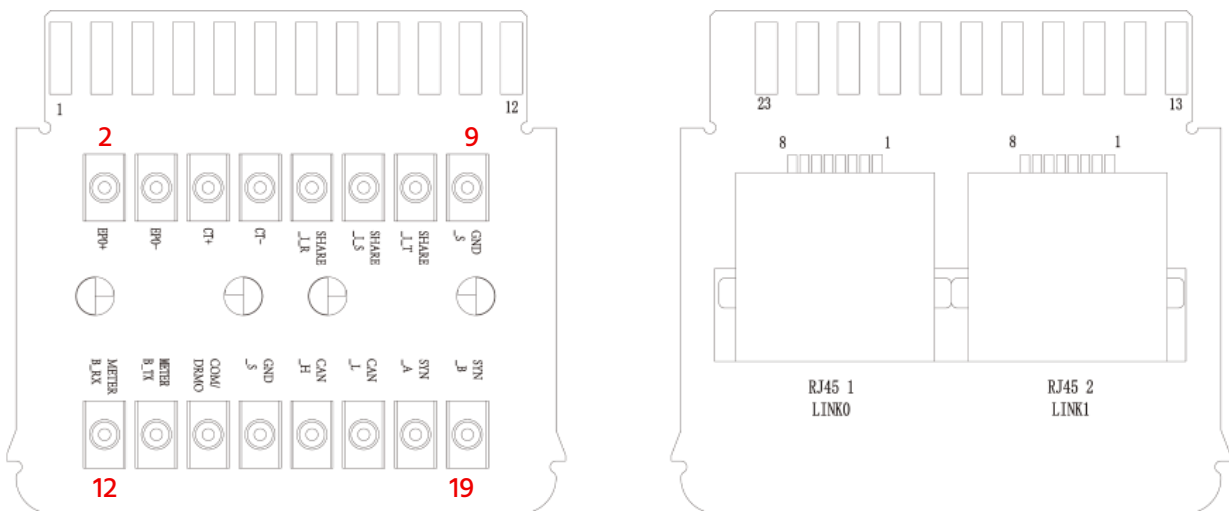

Note: For CT, S1:White, S2:Black

S1 connected to PIN4_CT+, S2 connected to PIN5_CT-

CT towards to inverter.

If meter is needed, the communication is by PIN12 and PIN13.

PIN12 connected to meter 9 B-, PIN13 connected to meter 10 A+.

Pin	Definition	Description
Pin 2	EPO+	Emergency stop button signal, to be short-circuited via external switch, for manual quick stop in case of emergency
Pin 3	EPO-	
Pin 4	CT+	For communication connection to CT
Pin 5	CT-	
Pin 6	SHARE_I_R	For parallel connection

Pin	Definition	Description
Pin 7	SHARE_I_S	
Pin 8	SHARE_I_T	
Pin 9	GNDS	
Pin 12	METER B_RX	For communication connection to meter (1P/3P)
Pin 13	METER B_TX	
Pin 14	DRM0	For AS4777 standard (Only DRM0 is available)
Pin 15	GNDS	
RJ45-1	LINK0	For parallel connection
RJ45-2	LINK1	For parallel connection

9. Push the terminal plug into the housing until there is an audible click.
10. Install back the rubber gasket into the housing and Insert the rubber plugs in the empty holes of the rubber gasket.
11. Fasten the swivel nut to the housing with a torque of 2.5+/-0.1 N·m.

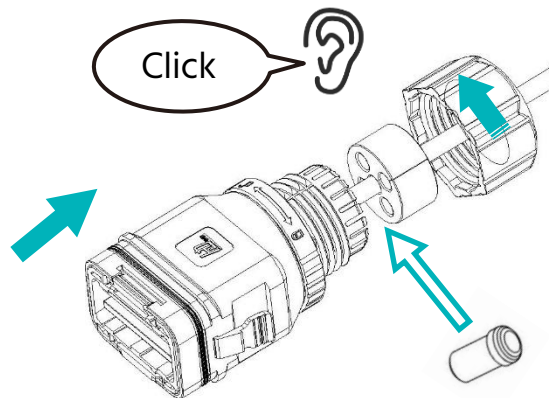

4.11.2 Communication Connector Connection

Procedure

1. Remove the waterproof lid from the communication terminal.
2. Insert the connector into the terminal until there is an audible sound.

Note: The inverter has not been tested to AS/NZS 4777.2:2020 for multiple inverter combinations and/or multiple phase inverter combinations, so combinations should not be used or external devices should be used in accordance with the requirements of AS/NZS 4777.1.

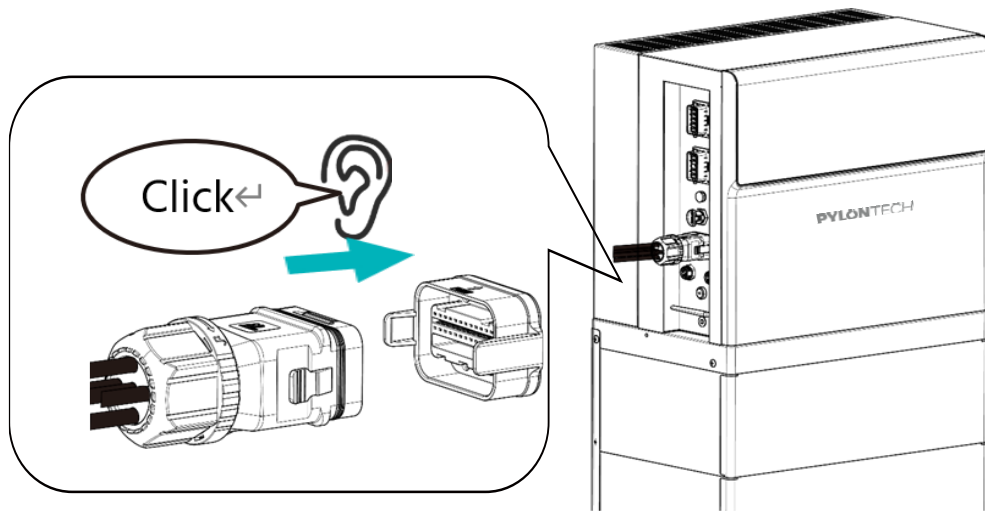

5 Commissioning

5.1 System Turning On

Safety Check Before Power ON

Please check the following before switching on any power supply connected to the FH3X system and switching on the PV switch of the power controller:

Grid:

- Grid voltage: check that the grid voltage at the point of connection to the FH3X system complies with the permissible range of the FH3X system (L-N: 172.5-264.5 Vac).
- Grid connector and wire assembly: Check that the wires on the AC side are assembled correctly and that the AC connector is mounted correctly and securely. Check that the AC connectors are securely plugged into the AC terminals.

Backup:

- Back-up connector and wire assembly: Check that the wires are correctly assembled on the load side, and check that the back-up connector is securely inserted into the back-up terminals.

PV:

- PV connectors: Check that the PV connectors are properly installed on the terminals.
- DC Voltage: Check that the maximum open circuit voltage of the PV array complies with the permissible range.
- DC Polarity: Check that the wires from the DC voltage source are connected to the terminals with the correct polarity.
- Ground resistance: Check that the ground resistance of the PV string is greater than 1 M Ω using a multimeter.

Overall:

- Cables: Check that all cables are securely connected. Check that the connections are valid and that the insulation is not damaged.
- Grounding: Use a multimeter to check all grounding and check that all exposed metal parts of the system are properly grounded.

Procedure

1. Turn on the battery switch at the right side of the power controller.

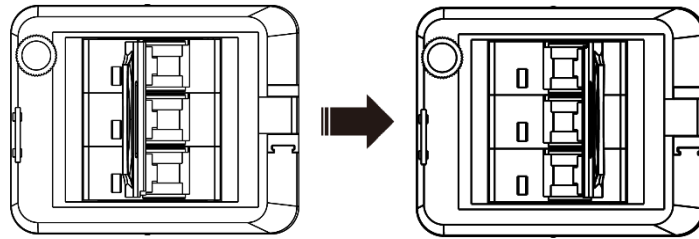

2. Turn on the AC switch between the FH3X and the power grid.
3. Turn on the PV switch at the right side of the power controller.

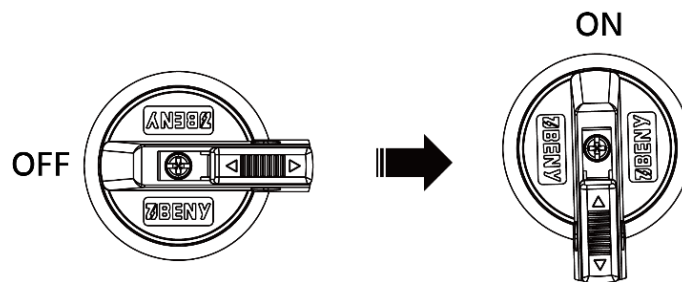

4. (Optional) Turn on the DC switch between the FH3X and the PV string if there is any.
5. Observe the LEDs to check the system operating status.

The detailed description of LED can be found in *Section 5.3 LED Introduction and Debug*.

If the system has to be powered on without PV and Grid, you can first turn on the battery switch and then press the start button on power controller for 1 seconds.

5.2 Energy Management

5.2.1 WI-FI Information

Manufacturer: Pylon Technologies Co., Ltd.

Address: Plant 8, No.505 Kunkai Road, JinXi Town, 215324 Kunshan City, Jiangsu Province, PEOPLE'S REPUBLIC OF CHINA

Basic Information of Wi-Fi	
Wi-Fi	IEEE802.11b/g/n/ax @2.4GHz
Wi-Fi frequency range	2412~2472MHz
WIFI maximum transmission power	18.63dBm
Bluetooth frequency range	2402~2480MHz
Bluetooth maximum transmission power	6.94dBm
Type of antenna	2.4G IPEX-SMA Antenna

5.2.2 App Download

The FH3X system must be operated by Pylon Cloud, to meet the needs of different user groups, FH3X provides two distinct applications for distributor/installer and end-user.

- For distributors/installers: PylontechPro
- For end-users: Pylontech

NOTE: The FH3X system should be online and the plant need to be established. If the system is not be networked, the warranty will be shortened to 5 years (normally 10 years with network).

Please search **PylontechPro** (for distributors/installers) or **Pylontech** (for end-users) in the App Store or GooglePlay to download it.



Scan the following QR code to obtain the SOP for PylontechPro/ Pylontech.



PylontechPro



Pylontech

For more details of APP usage, see the PylontechPro/ Pylontech user manual.

NOTE: The APP is continuously undergoing iterative updates.

5.2.3 Working Mode

Intelligent Dynamic Mode(P0)

This is the AI mode. The system will automatically train for 30 days, after it is first installed and powered on. During these days, real-time local electricity prices, weather and sunlight conditions (for PV) will be recorded, and continuously sample battery parameters and load usage. After 30 days of training, the dynamic mode will be mature enough.

In Intelligent dynamic mode, the system will automatically calculate when to buy, sell or store electricity to minimize costs and maximize revenue.

Self-Consumption Mode(P1)

This is the default mode and is designed to maximize the use of PV energy.

In self-consumption mode, the PV energy is prioritized as Load > Battery > Grid, which means that the energy generated by the PV is prioritized for supply to the local load, the excess energy is used to charge the battery, and the remaining energy is fed into the grid or will be limited (depending on the 'Power to grid').

If the PV energy is insufficient, the battery will discharge to meet the load demand.

If it is still insufficient, the load will draw power from the grid to meet the demand.

Backup Mode(P2)

In this mode, PV energy is prioritized as Load > Battery > Grid, i.e. the energy generated by the PV is prioritized for local loads, the excess energy is then supplied to the charging the battery, and the remainder of the energy fed into the grid (may be limited depending on the 'Meter Limiting Power').

If the PV energy is insufficient, the batteries will draw power from the grid for fully charging and the grid will supply the loads at the same time.

Feed in Priority Mode(P3)

In this mode, the system can get some revenue from grid connection and it is recommended to select this mode when the grid feed in revenue is high.

The priority of PV energy is Load > Grid > Battery, i.e. the energy generated by the PV is prioritized to supply the backup loads, the excess energy is fed into the grid for revenue, and the remaining energy is used to charge the battery.

When the PV energy is limited and cannot meet the demand of 'Power to grid', the battery will discharge to meet the feed-in power demand in order to maximize revenue.

Full Off-Grid Mode(P4)

In this mode, the system will disconnect the grid connection.

The priority of PV energy is Load > Battery, i.e. when there is enough PV energy, the energy is supplied to the load first, and the remaining energy is used to charge the battery.

If the PV energy cannot satisfy the load, the battery discharges to supply the load until the 'Discharge Limited SOC for off-grid' is reached.

5.2.4 Commissioning

In the 'PylontechPro' App, during the commissioning, you can find how to:

- Selecting Region settings for power quality response modes and grid protection
- Adjusting power quality response mode setpoints
- Adjusting grid protection settings setpoints
- Inverter firmware version

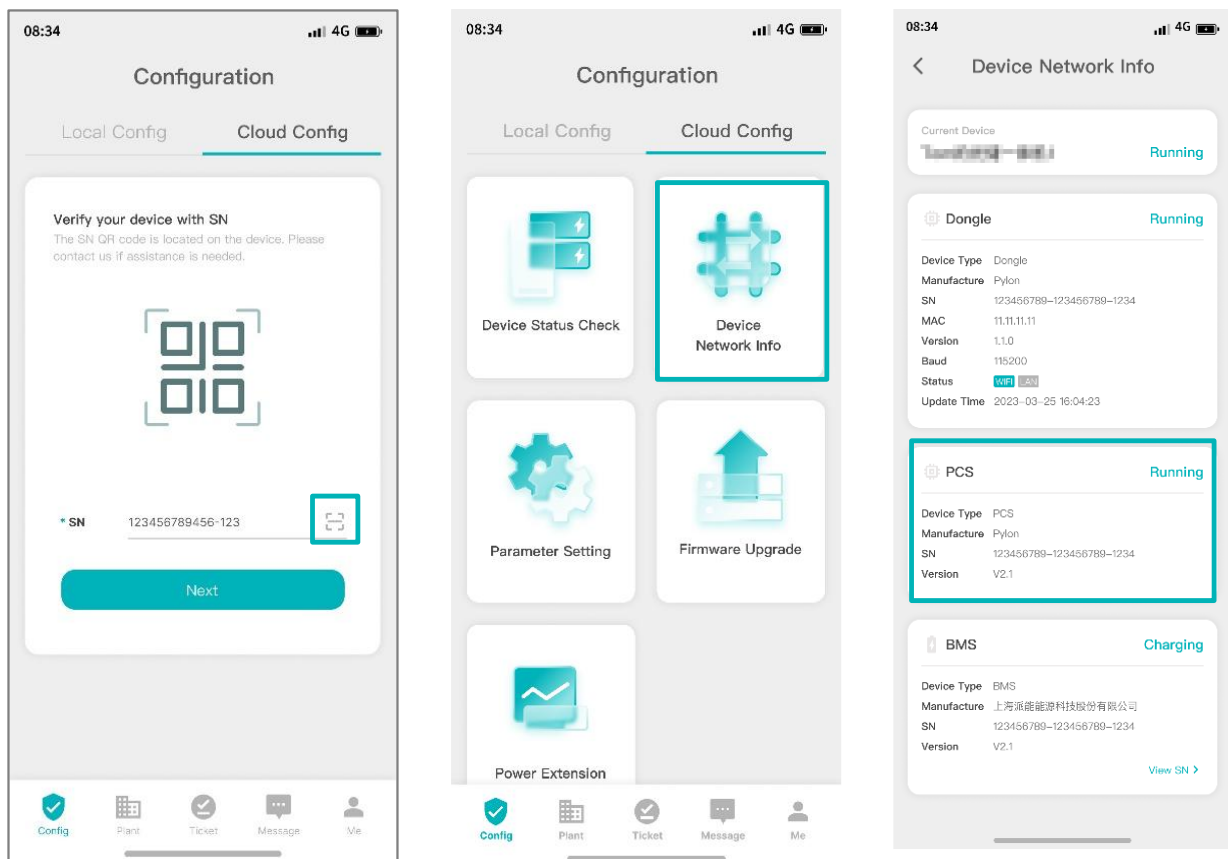

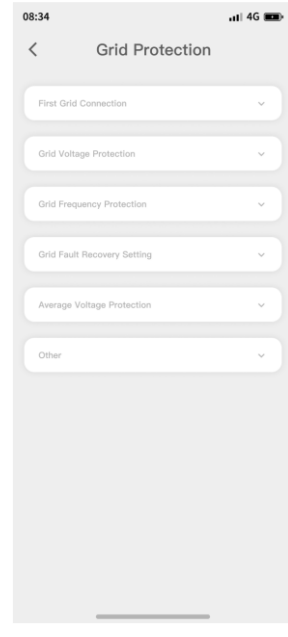
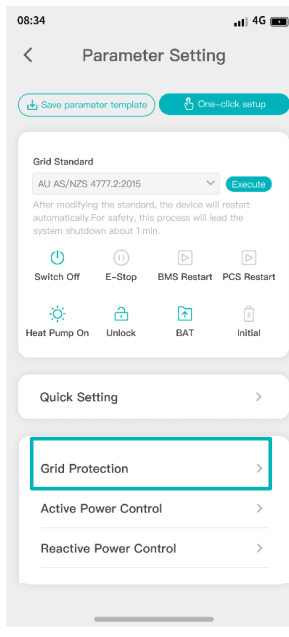
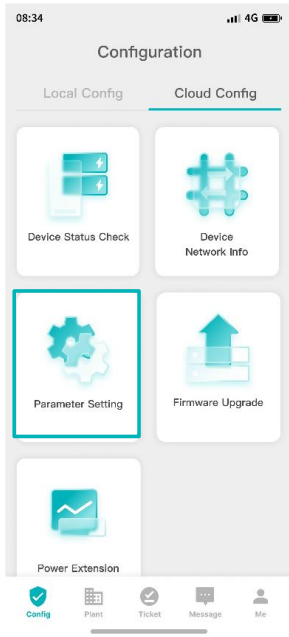
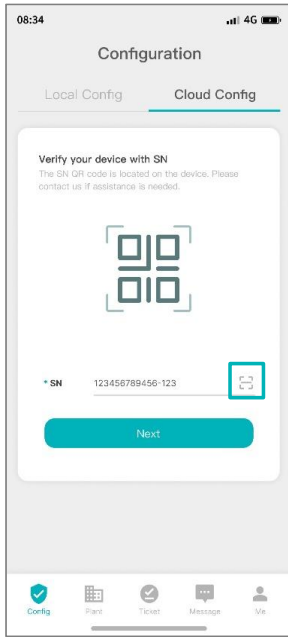

5.2.5 Charge/Discharge Time Control

The screenshot shows the 'Energy Management' app interface. At the top, there is a back arrow and the title 'Energy Management'. Below this is a dropdown menu for 'Energy Configuration'. The main section is titled 'Charge/Discharge Time Control' and contains several settings:

- Time Period:** A dropdown menu set to 'Charge/discharge time set 1'.
- Start Time:** A time picker set to '00:00'.
- End Time:** A time picker set to '15:00'.
- Charge/Discharge Power:** A numeric input field set to '100.0' with a '%Pn' label.
- Charge/Discharge Mode:** A dropdown menu set to 'Charge'.
- Repetition Time:** A dropdown menu set to 'Sunday, Monday, Tuesday, Wednesday, Th...'.
- State:** A dropdown menu set to 'Open'.

A blue 'Save' button is located at the bottom right of the screen.

In the charge/discharge time control, four time periods can be set respectively, and each time period can be assigned according to the mode selection.

If the time control is open:

In the charge period, if the PV energy is sufficient, the PV energy is prioritized as Battery > Load > Grid (if the feeder is allowed); if the PV energy is insufficient to charge the battery and meet the home load, the insufficient electricity will be taken from the grid.

In the discharge period, if the PV energy is sufficient, battery will not charge to the load; if the PV energy is insufficient, battery will discharge at the setting power until the 'Discharge limited SOC'.

No.	Item	Setting Range
1	Start time	0-24 hours
2	End time	0-24 hours
3	Charge/Discharge power	0-100%
4	Mode	Charge/Discharge

5	Repetition time	Any combination from Monday to Sunday
6	State	Open/Closed.

NOTE: The time control only lower priority than Intelligent dynamic mode.

5.3 LED Introduction and Debug

When the system is switched on, you can observe that the system LED display is illuminated for 60 seconds. Subsequently, each time you want to view the display, you can do so by pressing the start button for 2 seconds. In addition, the LED is automatically illuminated whenever the system changes operating mode or fails. The LEDs are explained as follows.

First startup of a single-string system

All the lights are on for 4 seconds (two-color lights are on for 2 seconds + 2 seconds), indicating the self-test. And then it enters the self-test and lights up for 30 seconds. (Each startup).

First startup of a multiple-string system

All lights of each string are on for 4 seconds, (dual-color lights are on for 2 seconds + 2 seconds), and then digital displays 'A-', indicating the address. Until the address allocation is successful, it displays A * (1~6) each specific address 4s, and then enters the self-test and lights up for 30 seconds. (Each startup)



Self-test

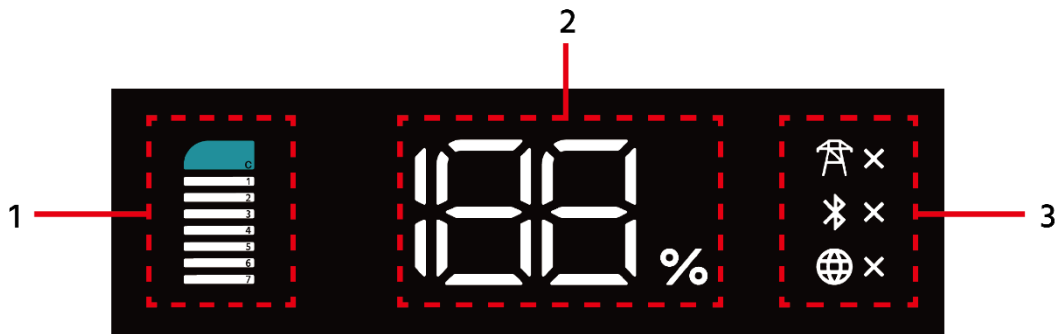

Indicating the power controller is in power-on self-test state. At this time the system has no output. Digital displays '--', and white color is always on.

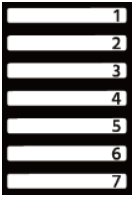

No.	Name	Description
1	Overall system status	Displayed according to the actual situation.
2	Digital display	Priority displays P* mode, 4 seconds, and then alternately displays (if there is a relevant state) E*/F*/L*/SOC/each 2s. (If the E/F/L fault is not triggered, it will not be displayed.)
3	Special symbols	Displayed according to the actual situation.

Here is the detail description of the LED light.

Icon	Description	Color
	Constant light: Resolve the specific problem in conjunction with the digital screen. A safety related, high level fault has occurred in the system including but is not limited to: power controller-side failure, storage-side failure, interlock due to master-slave failure, emergency stop, battery communication loss, not including off-grid.	Orange
	Flashing: analyze the specific problem in conjunction with the digital screen, indicating that protection has occurred in the system section. It stops working.	Orange
	Flashing: The system upgrade is in progress	1s/1s
	Flashing: working in maintenance mode, without battery.	Blue 0.5s/0.5s
	Constant light: in normal operation.	Blue
	Constant light: charging, displaying the number of connected modules.	White
	Flashing: discharging, displaying the number of connected modules.	White 1s/1s
	Flashing: standby (current to be determined), displaying the number of connected modules.	White 1.5s/0.5s
	Flashing: only serial number 7 battery module blinks, indicating sleeping mode.	White 1s/1s
	Constant light: energy storage controller related faults and unrecoverable protection, such as system voltage, current, all access to the battery module to participate in the display. If a single cell related fault, the corresponding module changes.	Orange
	Flashing: Energy storage controller related protection, such as system voltage, current, all access to the battery module to participate in the display. If single cell related protection, the corresponding module changes.	Orange 1s/1s
	SOC display, range 1~100%	White
	Information Display	White
	A*: Address	

	P*: Mode [see the definition of human-machine interaction].	
	P0: Intelligent dynamic mode	
	P1: Self-consumption mode	
	P2: Backup mode	
	P3: Feed in priority mode	
	P4: Full Off-Grid mode	
	P5: Charge/Discharge time control	
	P6: After-sales maintenance mode	
	Others reserved.	
	E*: 【Definition based on power controller failure mode】	
	F*: 【Based on the system failure mode definition】	
	L*: 【Based on the battery failure mode definition】	
	Solid: AC Grid connected and in On-Grid mode.	white
	Flash: AC Grid connected and in the Off-Grid mode.	White 3s/3s
	Solid: AC Grid disconnected.	White 1s/1s
	Solid: Bluetooth device is connected.	White
	Flash: Bluetooth device is not connected.	White 1s/1s
	Solid: Internet is connected.	White
	Flash: Internet is configured but offline.	White 3s/3s
	Flash: Internet is not configured.	White 1s/1s

6 Maintenance

6.1 System Turning Off

DANGER

Danger: When any failure occurs or there is a need for service, the battery storage system must be powered off at first.

Precondition

Before performing any internal operations on the FH3X system, disconnect the system from all voltage sources as described in this manual.

Procedure

These steps must be performed in the order described.

1. Turn off the device by using the parameter modification in the App or Website
Switch off the device by using the “switch off” button in the app or website.
2. Disconnect the breakers on the load and grid sides
3. Disconnect the breakers on the load, grid and PV (if any) sides.
4. Set the PV switch of the controller to the “OFF” position
5. Turn off the battery switch. At this time, there is remaining power in the controller capacitor.
Waiting for 5 minutes until the controller is completely de-energized before operation.

CAUTION

Caution: When replacing batteries, ensure that the new battery and the old battery are of the same type.

Before replacing the battery module for service, make sure to charge the new and the old battery modules both to 100% SOC separately. Otherwise the system needs long time to do balance for this replaced battery module and the SOH of battery may be reduced greatly.

NOTE:

It is recommended to additionally lock the PV switch for maintenance shutdowns.

PV switch type: BYSS.1-32/T

The procedure of lock the PV switch is as follows.

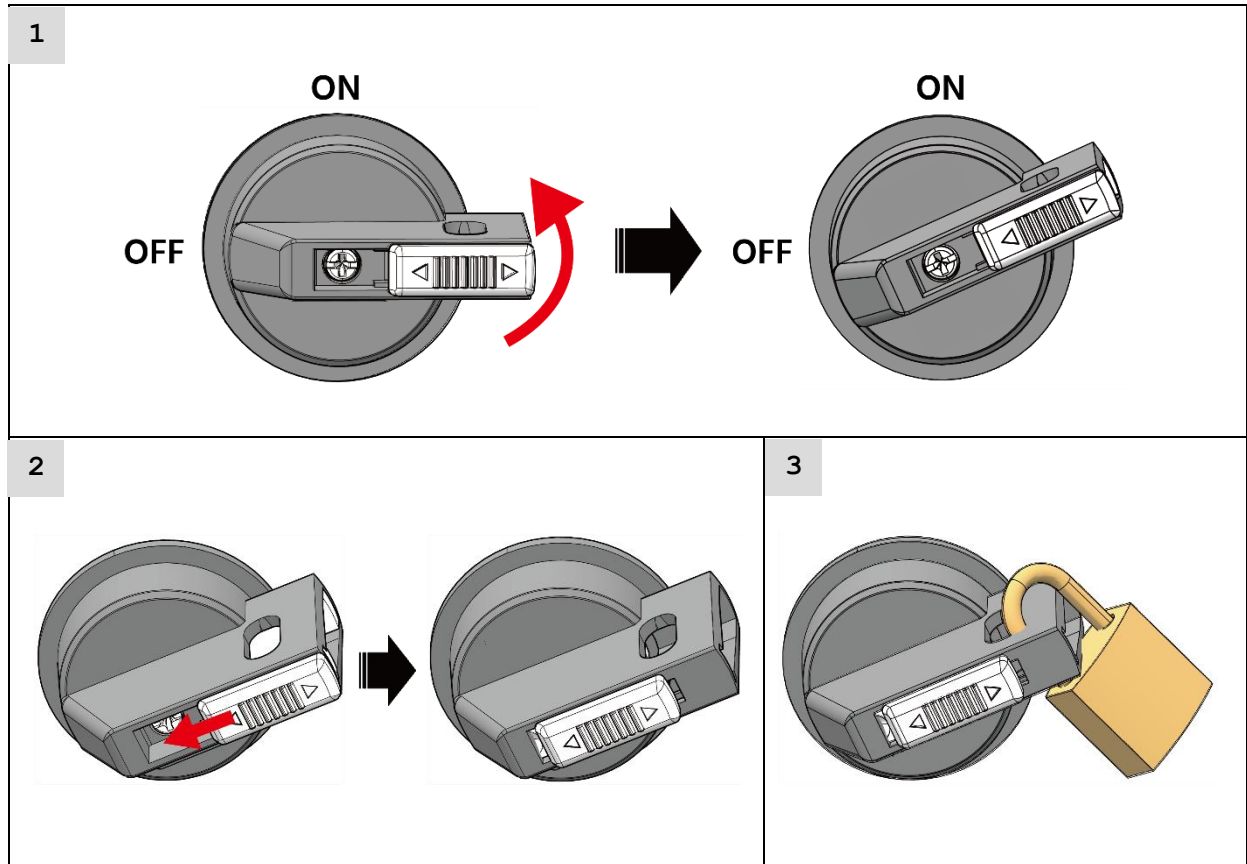

It is recommended to additionally lock the battery switch to prevent accidental contact by personnel as follow.

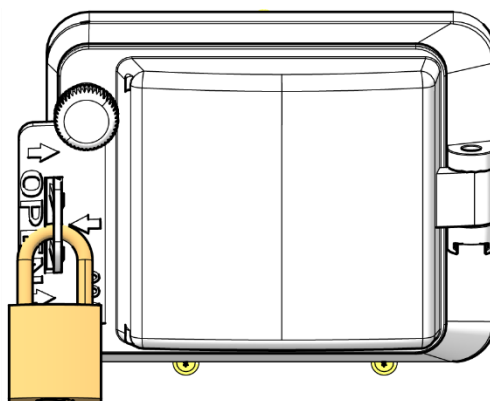

The lock is not in the FH3X packing box. Please prepare it yourself

6.2 System Maintenance

 **DANGER**

Danger: The maintenance of system must be done by qualified and authorized person only.

 **DANGER**

Danger: The power must be turned off prior to any maintenance of the system.

 **DANGER**

Danger: Do not maintain the battery while it is short-circuited and on fire, the battery may explode, spatter and release toxic gases.

Do not disassemble or damage the battery. A broken battery may leak electrolyte, which is corrosive and has a toxic odor, so take care to avoid contact with skin and eyes.

Voltage Inspection

Check the voltage of battery system through the monitor system. Check if the system is abnormal voltage. For example: Single cell's voltage is abnormally high or low.

SOC Inspection

Check the SOC of battery system through the monitor system. Check if the battery string is abnormal SOC.

Cable Inspection

Visual inspect all the cables of system. Check if the cables are broken, aging, or getting loose.

Output Relay Inspection

Under low load condition (low current), switch the output relay to OFF and ON to hear the clicking sound, which means this relay can be turned off and on normally.

Environment Inspection

Check the installation environment such as dust, water, insect etc. Ensure that it is suitable for IP65 battery system.

It is recommended that the system be maintained at least every six months.

6.3 Troubleshooting

DANGER

Danger: This system is a high voltage DC system, operated by qualified and authorized person only.

DANGER

Danger: Before checking the failure, ensure to check that all the cables connection and the BESS system can be turned on normally.

The following fault codes are displayed on the LED display on the power controller.

No	Fault Code	Problem	Possible Reason	Solution
1	L0	Overheating	The system charges and discharges the battery with high power for a long time	Reduce the load or stop charging and discharging the battery, and use the energy storage system reasonably.
			Abnormal heat dissipation of the system	The system should be installed in a space of at least 30 mm from the wall. If the system is installed indoors, ensure that the installation environment is well ventilated and avoid significant indoor temperature rise by 3°C while the system is running,
			Direct sunlight on the energy storage system or fire source, heat source around the energy storage system.	Avoid direct sunlight where the energy storage system is installed, and ensure that the installation area is far away from fire and heat sources.
			Battery system false alarm	Restart the system to confirm whether the fault persists.
2	L1	Under-temperature	System ambient temperature is too low	External physical heating of the energy storage system
			Battery system false alarm	Restart the system to confirm that the fault persists
3	L2	Overvoltage	Battery system false alarm	Restart the system to reconfirm
			The charging current control accuracy of the	Contact the manufacturer for confirmation

No	Fault Code	Problem	Possible Reason	Solution
			controller is abnormal	
			Battery module damaged	Contact the manufacturer for confirmation
4	L3	Undervoltage	Off-grid operation, excessive standby time after discharge cut-off	Set the cut-off SOC reasonably, and recharge the battery in time after discharging.
			Batteries left in place too long	Recharge the battery on time when it is left in place without use.
			Battery system false alarm	Restart the system to reconfirm.
			Battery module damaged	Contact the manufacturer for confirmation.
5	L4	Sleep	Grid-connected operation, battery failure resulting in severe battery undervoltage	Contact the manufacturer for any unrecoverable faults in the system operation.
			Off-grid operation, controller control circuit failure resulting in severe battery over-discharge	Contact the manufacturer for confirmation.
6	L5	Charge overcurrent	Battery system false alarm	Restart the system to reconfirm.
			The current control accuracy of the controller is abnormal	Contact the manufacturer for confirmation.
7	L6	Discharge overcurrent	Load overrun	Set the load appropriately..
			Low number of batteries	Configure the number of battery modules appropriately.
			The current control accuracy of the controller is abnormal	Contact the manufacturer for confirmation.
			Battery system false alarm	Restart the system to reconfirm.
8	F2	Other routine failures that can be recovered	False alarms or communication abnormalities	Wait for recovery or restart, and contact the manufacturer for confirmation if the fault cannot be solved.

No	Fault Code	Problem	Possible Reason	Solution
9	F3	System Failures	False alarm or abnormal self-test	Restart and reconfirm, and contact the manufacturer for confirmation if the fault cannot be solved.
10	F4	Critical Failures	The battery cell is damaged.	Please contact the manufacturer to change the battery.
11	FF	WIFI collector communication failure	Abnormal communication between storage system and collector	Restart and reconfirm, and contact the manufacturer for confirmation if the fault cannot be solved.
12	FG	Earth Fault	Earth fault detected	Fault information will be pushed as notifications on the 'Pylontech Pro' and 'Pylontech' app. Please contact the manufacturer for confirmation if the fault cannot be solved.
13	E0	PV overvoltage protection	Mismatch between PV input and device parameters	Please make sure that the input parameters of PV meet the requirements of equipment parameters.
			False alarm of energy storage system	Restart the system to reconfirm.
			Abnormal PV detection of energy storage system	Contact the manufacturer for confirmation.
14	E1	Battery voltage overrun	The number of batteries exceeds the upper limit of equipment support.	Confirm the equipment specifications and the maximum number of batteries to be connected, and reasonably configure the number of batteries.
15	E2	Battery not connected	Battery not installed in energy storage system	The whole energy storage system must be used together with batteries, otherwise the system itself does not meet the IP rating.
			Abnormal system detection	There are actually batteries, but the reported batteries are not connected. Contact the manufacturer for confirmation.
16	E3	AC overvoltage/undervoltage protection	Wrong choice of grid standards	Ensure that the power grid standard is correct.
			Grid instability, unusual fluctuations	Ensure that the power grid is available and stable.
			Others	Contact the manufacturer to confirm.

No	Fault Code	Problem	Possible Reason	Solution
17	E4	AC over-frequency and under-frequency protection	Wrong choice of grid standards	Ensure that the grid standard is selected correctly.
			Grid instability, unusual fluctuations	Ensure that the power grid is available and stable.
			Others	Contact the manufacturer to confirm.
18	E5	Controller over-temperature protection	Long time high power operation of the system	Reduce the load
			Abnormal heat dissipation of the system	Ensure that there is room for heat dissipation in the controller heat sink, and the installation environment is well ventilated as much as possible.
			Direct sunlight on the energy storage system or fire source or heat source around the energy storage system.	Avoid direct sunlight on the installation location of the energy storage system, and ensure that the installation area of the system is far away from fire and heat sources.
			False alarms	Restart the system to confirm whether the fault persists.

More alarm information can be checked in the App PylontechPro/Pylontech.

Once a certain failure is detected following the trouble shooting procedure, turn off the system (>>> see *Section 6.1 System Turning Off*) first before replacement so as to avoid further over discharge to the system due to the self-consumption.

6.4 Replacement of Main Components among the BESS

DANGER

Danger: This system is a high voltage DC system, operated by qualified and authorized person only.

6.4.1 Replacement of Battery Module

Procedure

1. Charge existing module to full (SOC 100%). Ensure that new battery module is 100% SOC as well.
2. Follow the procedure of turning off the system (>>>see *Section 6.1 System Turning Off*) and ensure that the system has been completely shut down.
3. Disconnect the AC cables, DC cable, communication cable and grounding cable.
4. Dismantle the anti-toppling brackets.

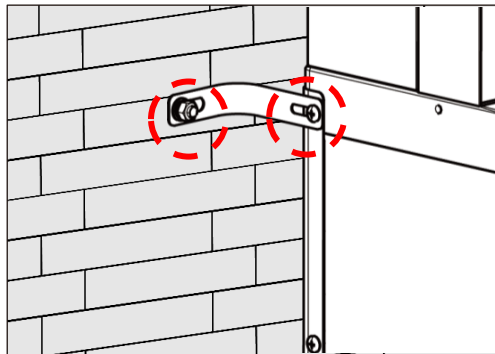

5. Dismantle the metal brackets at both back sides of the battery modules (see the figure below).

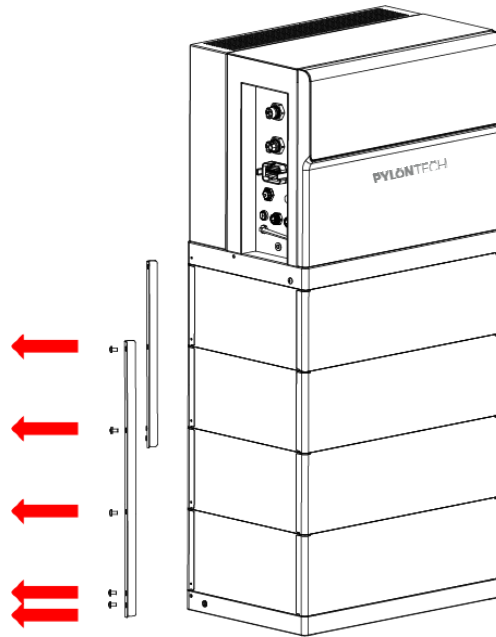

6. Dismantle 2 M4 screws on both sides of the power controller base.

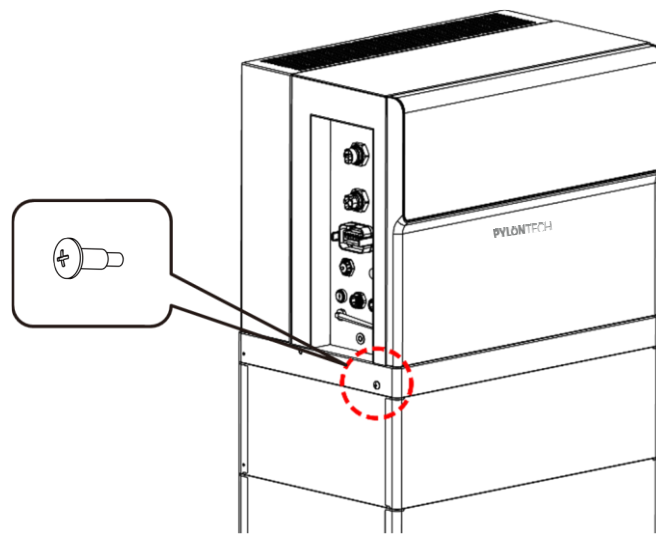

7. Remove the power controller and each battery module one by one.

⚠ DANGER

Danger: When battery is connected together with the base, the internal socket still has high voltage DC power from serial connected battery modules.

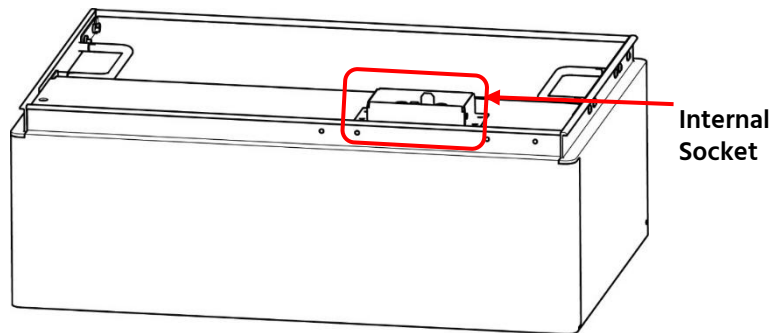

⚠ WARNING

Warning: Single battery module weights 39 kg. If there are no handling tools, at least more than 2 people are needed to handle with it.

NOTE: Before replacing the new battery module, please compare the production dates of the old and new batteries. The production date of the old battery module can be found on the label affixed to the battery casing, while the production date of the new battery module can be found on the label on the packaging. Please ensure that the time interval between the two dates is within one year.

8. Pile up the new battery module. And install back the battery modules and power controller.
9. Fix back the 2 M4 screws on the power controller base. And install back the metal brackets and anti-toppling brackets.
10. Install back grounding cable, communication cable, DC cables and AC cables.
11. Turn on the system (>>> see *Section 5.1 System Turning On*).

6.4.2 Replacement of Power Controller

Procedure

1. Follow the procedure of turning off the system (>>> see *Section 6.1 System Turning Off*) and ensure that the system has been completely shut down.
2. Disconnect the AC cables, DC cable, communication cable and grounding cable.
3. Dismantle the anti-toppling brackets (>>> see *Section 6.4.1 Replacement of Battery Module*).
4. Dismantle the metal brackets at both back sides of the battery modules (>>> see *Section 6.4.1 Replacement of Battery Module*).
5. Dismantle 2 M4 screws on both sides of the power controller base (>>> see *Section 6.4.1 Replacement of Battery Module*).
6. Remove the power controller.
7. Pile up the new power controller.
8. Fix back the 2 screws on the power controller base. And install back the metal brackets and anti-toppling brackets.
9. Install back grounding cable, communication cable, DC cable, and AC cables.
10. Turn on the system (>>> see *Section 5.1 System Turning On*).

7 Expansion Services

FH3X series products support system power expansion, the power of the system can be expanded to the maximum power supported by the system.

For the system of which power is 3.6kw, 5kw or 6kw, it can be upgraded to a maximum of 8kw through the paid service (for the 3.6kw system, you can choose to upgrade to 5kw, 6kw, and the other is also the same).

This is a great feature for first time installations where you choose a lower power device, and then later on, if your household power needs increase or you want to increase the power of your device for other reasons. For details on how to implement this, please contact your local dealer or email service@pylontech.com.cn.

8 Shipment and Storage

8.1 Shipment

The battery module and the power controller of FH3X system are shipped separately, due to its flexible installation configuration, customers are free to choose the power controller and the number of battery modules. Then simple stack and assemble to complete the system installation.

Before shipment, single module is pre-charged to about 100% SOC, or according to customer requirements. After delivered on-site, the remaining battery capacity is determined by the storage time and condition.

- The battery modules should meet the UN38.3 certificate standard.
- In particular, local rules and policies (e.g. ADR: European Agreement concerning the International Carriage of Dangerous Goods by Road) for the product transportation shall be complied with. For more details, please enquiry the Safety Data Sheet (SDS) from Pylontech: service@pylontech.com.cn.

8.2 Storage

It is not recommended to leave the battery unused for a long time. If it needs to be stored for a long time indeed, please follow the suggestions:

- When the system is installed and in the normal operation stage, such as plans to go out for a long time or not used, it is suggested to charge the battery to more than 90% SOC. disconnect all the power supply switch of the system to maintain a complete power-off state, the system is expected to be available to maintain self-consumption for 6 months.
- The system storage temperature is -20 ~ 60 °C, recommended storage temperature 10 ~ 45 °C, humidity <65%;
- Do not separate the battery from the power controller for separate storage, and the system does not meet the IP65 protection rating when separated;
- After the system is separated or before installation, it is necessary to keep the battery and controller each placed in the original packing carton and resealed;
- If there is a situation where the battery is self-draining, the maximum time should not exceed 6 months. Ensure to replenish the battery and activate the battery (several cycles of charging and discharging). If it needs to be stored again, it is required to charge the battery again to save. It is recommended to maintain the battery by charging and discharging it at least every 6 months to avoid leaving it for too long.

CAUTION

Caution: If you do not follow the above instructions for long term storage of the system, the cycle life will decrease heavily.

9 Warranty Services and Repair

- In the process of system operation, there are various faults that cause the system can not be used, or there are frequent alarms that affect or do not affect the use of the system, you can feedback your problem through the work order in APP.
- In the process of system installation and operation, if you want to increase the battery module or if the battery module is faulty and needs to be replaced, please ensure that capacity of the new module is the same as that of the module being used. Normal new modules are fully charged, so you can first fully charge the running modules in the system before installing new ones to use together.
- In addition to the APP work order feedback, Any questions, problems or needs in the process of your use of ideas, you can also communicate with the dealer or contact experts from Pylontech: service@pylontech.com.cn
- In the product warranty time and warranty scope, if the product has quality problems, you can apply for warranty service. If the product meets the warranty conditions, it will be replaced or repaired for you.

10 Disposal

In case a battery (normal condition or damaged) needs disposal or needs recycling, it shall follow the local recycling regulations to process, and use the best available techniques to achieve a relevant recycling efficiency.

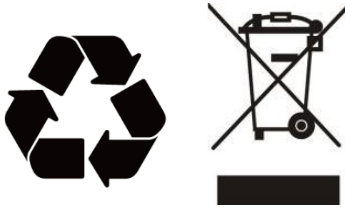

11 Technical Specifications

11.1 System Specifications

Specifications	FH3X-3.6K/5K/6K/8K-HY-1P-5/10/15/20			
Controller	FH3X-3.6K-HY-1P	FH3X-5K-HY-1P	FH3X-6K-HY-1P	FH3X-8K-HY-1P
Battery module	FH10050			
Number of battery modules	1/2/3/4			
System nominal capacity (kWh)	5.12/10.24/15.36/20.48			
System nominal power (kW)	3.6	5	6	8
DC (PV side)				
Maximum power (kW)	5.7	8	9.6	12.8
Maximum input voltage (V DC)	600			
Start up voltage (V DC)	80			
Mppt voltage range (V DC)	80~550			
Mppt full load voltage range (V DC)	190~520			
Number of mppt	2		3	
Number of PV strings per mppt	1			
Maximum current (A)	16/16		16/16/16	
Short circuit current per mppt (A)	25/25		25/25/25	
Max. inverter backfeed current to the array (A)	0			
Surge protection	Type II			
DC (Battery side)				
Maximum continuous charge/discharge current (A)	40/40			
The maximum charging power of the single-phase model with one battery (kW)	2.5			
The maximum discharging power of the single-phase model with one battery (kW)	2.5			
The maximum charging power of the	8			

Specifications	FH3X-3.6K/5K/6K/8K-HY-1P-5/10/15/20			
single-phase model with more than one battery (kW)				
The maximum discharging power of the single-phase model with more than one battery (kW)	3.6	5	6	8
AC (Grid side)				
Nominal grid voltage	1/N/PE a.c. 230 V			
Nominal grid frequency (Hz)	50/60			
Max. (rated) continuous current to grid (A)	15.7	21.7	26.1	34.8
Nominal active power to grid (W)	3600	5000	6000	8000
Max. (rated) apparent power to grid (VA)	3600	5000	6000	8000
Max.(rated) continuous current from Grid	23.5	32.6	39.1	52.2
Nominal active power from grid (W)	5400	7500	9000	12000
Max. (rated) apparent power from grid (VA)	5400	7500	9000	12000
Maximum output fault current (peak and duration)	94A@43ms			
inrush current (peak and duration)	46A@278us			
Power factor range	-0.8~+0.8			
THDi	<3%			
AC (Back-up)				
Nominal voltage	1/N/PE a.c. 230±1% V			
Max. (rated) continuous current (A)	15.7	21.7	26.1	34.8
Nominal output Frequency (Hz)	50/60			
Max. (rated) apparent power (VA)	3600	5000	6000	8000
Peak off-grid power (60s)/estimate (VA)	4320	6000	7200	9600
Power factor range	-0.8~+0.8			
ON/Off-grid Switching time (ms)	10			
THDv	<3%			

Specifications	FH3X-3.6K/5K/6K/8K-HY-1P-5/10/15/20
Efficiency	
Maximum efficiency	98%
European Efficiency	97.5%
Protection	
Anti-islanding protection*	Yes, frequency shift
AFCI	Yes
AFCI Type	F-I-AFPE-1-2-1 (For FH3X-8K-HY-1P) F-I-AFPE-1-2/1-2 (For FH3X-6K-HY-1P, FH3X-5K-HY-1P, FH3X-3.6K-HY-1P)
Reconnection method	Automatic reconnection
Insulation resistor detection	Yes
Residual current monitoring unit	Yes
Output over current protection	Yes
Output short protection	Yes
Output overvoltage protection	Yes
PV switch	Yes
DC reverse polarity protection	Yes
PV overvoltage protection	Yes
General Data	
Dimensions (W/H/D, mm)	540*665/835/1005/1175*350 (Height corresponds to 1~4 battery modules)
Weight (kg)	77/116/155/194 (Weight corresponding to 1~4 battery modules)
Operating temperature range (°C)**	-10~55
System working humidity range	0~100%
System working altitude (m)***	2000
Common noise level (1 meter) (dB)	< 30
Maximum parallel****	6
Protective class	I
Overvoltage category	DC II (PV) /AC III (Grid, Back up)
Inverter topology	Non-isolated
Ingress protection	IP65

Specifications	FH3X-3.6K/5K/6K/8K-HY-1P-5/10/15/20
System salt spray level	C5M
Cooling	Natural Cooling
Communication Portal	WIFI、WLAN、Bluetooth
Display	LED
EPO	Installed
Standard Compliance	UN38.3/IEC61000-6/VDE-AR-E-2510-50/IEC62619/IEC60730-1/ISO13849/IEC62109-1/IEC62109-2/IEC62040-1

*: Anti-islanding protection uses active methods, automatically enabled by grid standard.

** : When the ambient temperature exceeds 45°C, the PCS will reduce the power.

***:When the altitude exceeds 2000m, the PCS will degrade the power.

****: External device/s is/are needed when paralleling. (The inverter has not been tested to AS/NZS 4777.2:2020 for multiple inverter combinations and/or multiple phase inverter combinations)

11.2 Battery Specifications

Specifications	Values			
Cell Technology	Li-ion (LFP)			
Battery Module Capacity (kWh)	5.12			
Battery Module Voltage (VDC)	102.4			
Battery Module Capacity (Ah)	50			
Maximum continuous charge/discharge current (A)	50/50			
Battery Cell Voltage (VDC)	3.2			
Battery Cell Capacity (Ah)	50			
Dimension (W x D x H, mm)	540 × 350 × 170			
Weight (kg)	39			
Operation Temperature (°C)	-10 ~ 55			
Storage Temperature (°C)	-20 ~ 60			
Recommended Storage Temperature (°C)	10 ~ 45			
Battery Short Circuit Rating	4500 Amps / 1 milliseconds			
Transfer Certificate	UN38.3			
Model	FH3X-3.6K/5K/6K/8K-HY-1P-5	FH3X-3.6K/5K/6K/8K-HY-1P-10	FH3X-3.6K/5K/6K/8K-HY-1P-15	FH3X-3.6K/5K/6K/8K-HY-1P-20
Battery System Energy (kWh)	5.12	10.24	15.36	20.48
Nominal Battery System Voltage (VDC)	102.4	204.8	307.2	409.6
Battery Module Quantity (pc)	1	2	3	4
Battery System Charge Upper Voltage (VDC)	113.6	227.2	340.8	454.4
Battery System Discharge Lower Voltage (VDC)	92.8	185.6	278.4	371.2
Depth of Discharge (%)	100			

The actual discharge capacity varies depending on factors such as the current and temperature.



PylontechPro



Pylontech



Pylon Technologies Co., Ltd.

No.300, Miaoqiao Road, Kangqiao Town

Pudong New Area, Shanghai 201315, China

T +86-21-51317699

E service@pylontech.com.cn

W www.pylontech.com.cn