

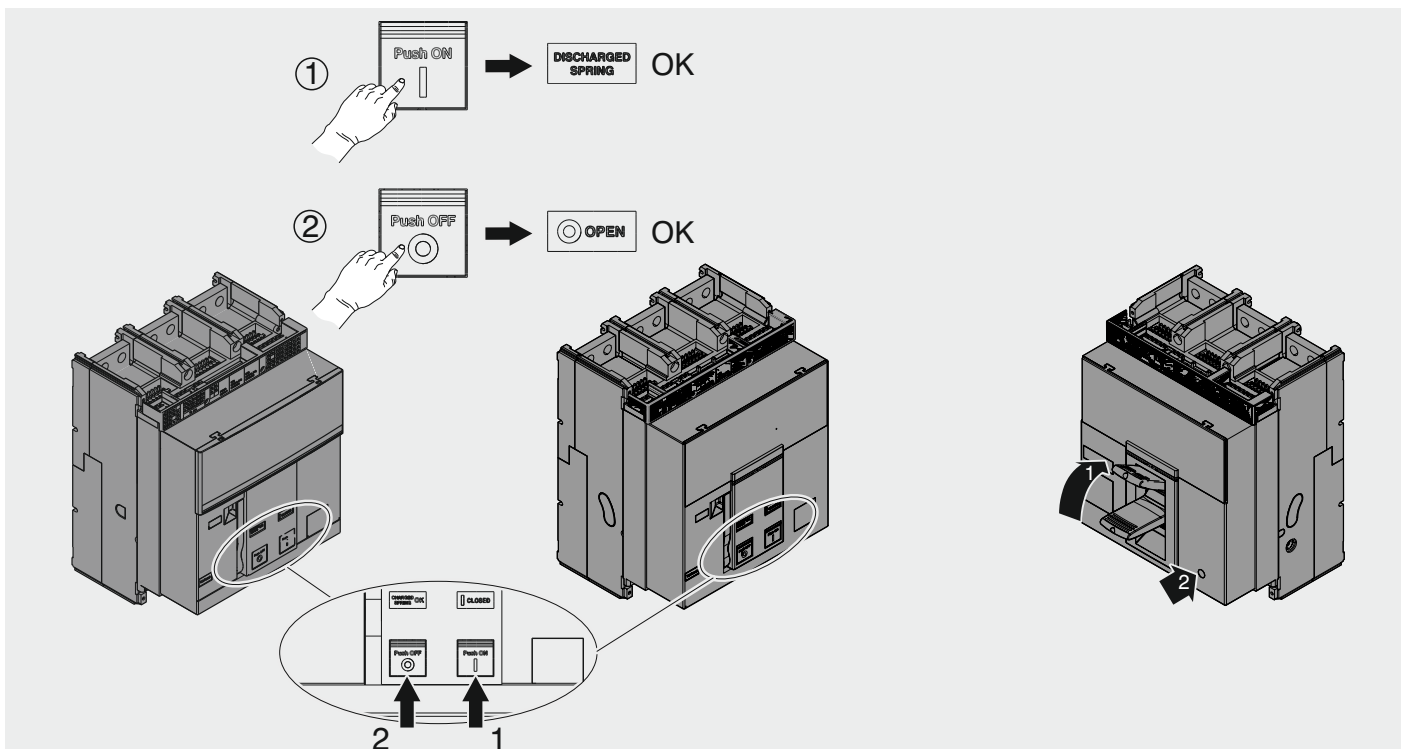

SACE Emax 2 - Tmax XT

Interblocco meccanico MI tipo A - E1.2 - XT7M - XT7
Mechanical interlock MI type A - E1.2 - XT7M - XT7
Mechanische Verriegelung MI typ A - E1.2 - XT7M - XT7
Verrouillage mécanique MI type A - E1.2 - XT7M - XT7
Enclavamiento mecánico MI tipo A - E1.2 - XT7M - XT7
机械式联锁 MI 类型 A - E1.2 - XT7M - XT7

E1.2 - XT7M - XT7



ATTENZIONE! Dove è indicato il simbolo  la lubrificazione deve essere effettuata con grasso tipo mobilgrease 28, disponibile anche nel greasing kit ABB (1SDA076082R1).

WARNING! Lubricate where indicated by the  symbol using grease of the mobilgrease 28 type, also available in the ABB greasing kit (1SDA076082R1).



ACHTUNG! Wo das Symbol  angegeben ist, muss die Schmierung mit Fett der Sorte Mobilgrease 28 ausgeführt werden, das auch im ABB Greasing Kit verfügbar ist (1SDA076082R1).

ATTENTION! Là où est indiqué le symbole  la lubrification doit être effectuée avec de la graisse type mobilgrease 28, disponible aussi dans le Kit greasing d'ABB (1SDA076082R1).

¡ATENCIÓN! Donde está indicado el símbolo  la lubricación se deberá efectuar con grasa tipo mobilgrease 28, disponible también en el greasing kit ABB (1SDA076082R1).









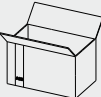

WD = Estraibile, Withdrawable, Ausfahrbar, Débrochable, Extraíble, 抽出式 1SDA073896R1

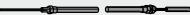









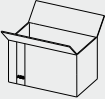

























WM = Montaggio a parete, Wall mounting, Wandanbau, Montage sur paroi, Montaje en la pared, 固定式墙面安装 1SDA073894R1

FM = Montaggio a pavimento, Floor mounting, Fußbodenanbau, Montage sur sol, Montaje en el suelo, 固定式地面安装 1SDA073893R1

INTERLOCK HARDWARE = Orizzontale, Horizontal, Horizontalen, Horizontaux, Horizontales, 水平 1SDA073881R1

Verticale, Vertical, Vertikalen, Verticaux, Verticales, 垂直 1SDA073885R1

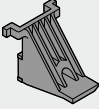
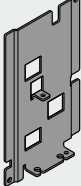
1x 	Group 1	INTERLOCK HARDWARE
1A		2
1B		2
1C	 M4x10	2
1D		8
1E		8
1F	 Ø _{int} 6	4
1G	 M4	2
1H	 M5	4
1I	 M6	4
1L		2

2x 		Group 3 / Group 4	WD	WM	FM		WM	FM
2A		  M4x12		2	2			
2B		  M4x10		2	6	2S		1
2C		  M4x30		2	2			
2D		  M5x25			4			
2E		 M4		2	4			1
2E1		 M4		2	4	2S1		
2F		 M5			4			
2G		 Ø _{int} 5			4			
2H		 Ø _{int} 4		2	2	2T	1	1
2I				2	2			
2J				1	1			
2K			2	2	2	2U	1	1
2L		  M5x8	2					
2M		  M4x16	1					
2N		 Ø _{int} 4	1			2V	1	
2O			1					
2P			1			2W	1	1
2Q			1			2X	1	1
2R			1			2Y	1	1
						2Z	1	1

1

F

Foratura piano di appoggio per passaggio cavi
 Mounting surface drilling for cable
 Bohrung Auflagefläche für Kabel
 Perçage plan d'appui pour le câble
 Taladrado de la superficie de apoyo para el cable
 电缆安装表面钻孔

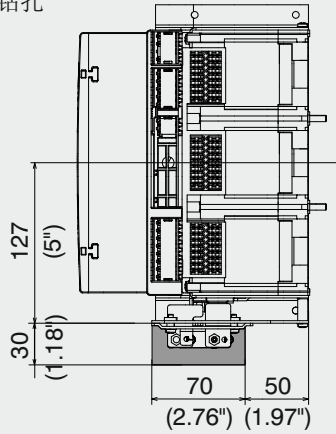

2

W

Foratura piano di appoggio per passaggio cavi
 Mounting surface drilling for cable
 Bohrung Auflagefläche für Kabel
 Perçage plan d'appui pour le câble
 Taladrado de la superficie de apoyo para el cable
 电缆安装表面钻孔

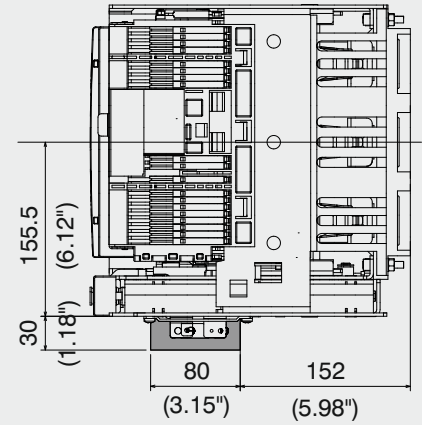

3

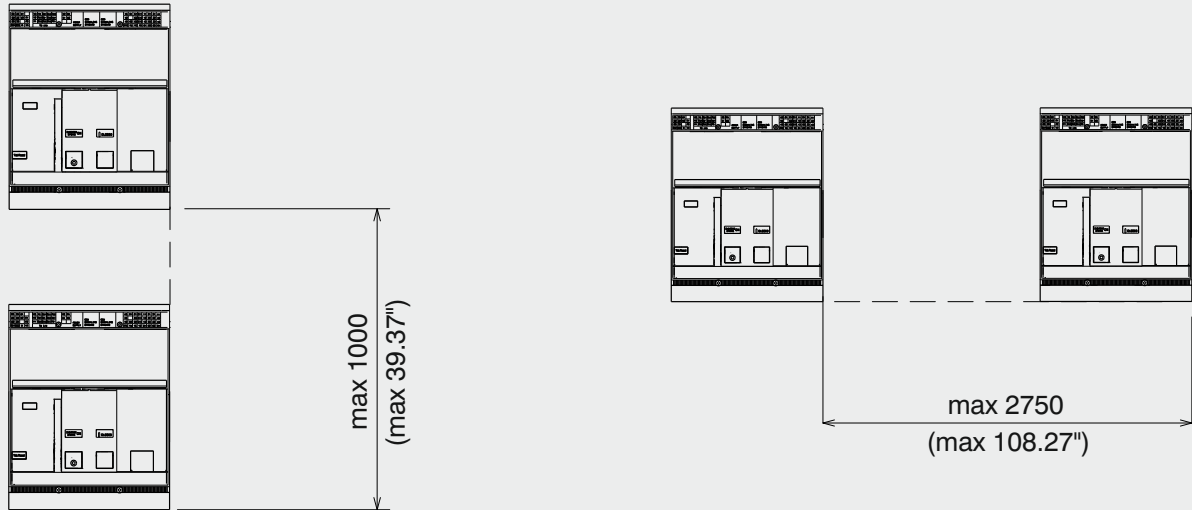

4

W

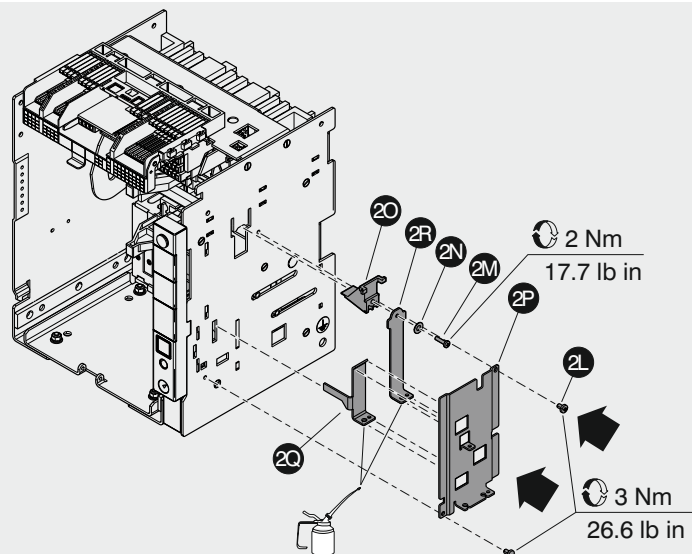

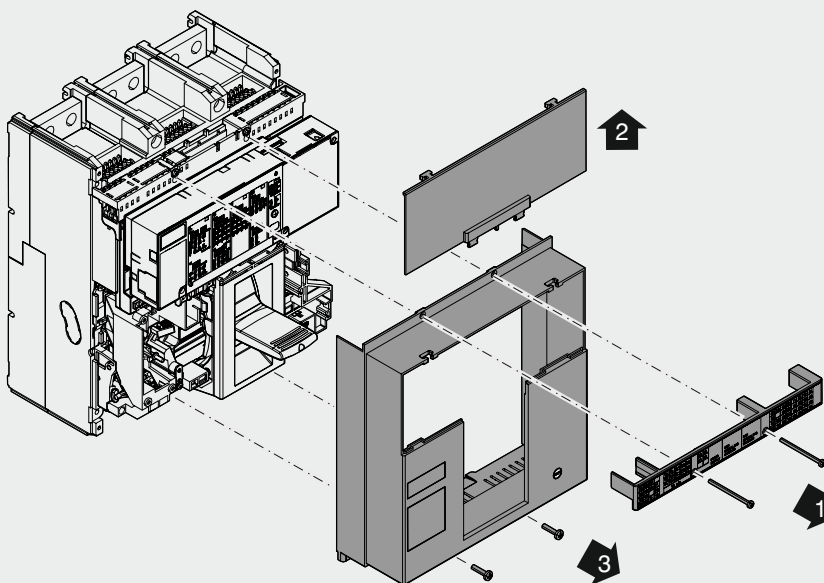
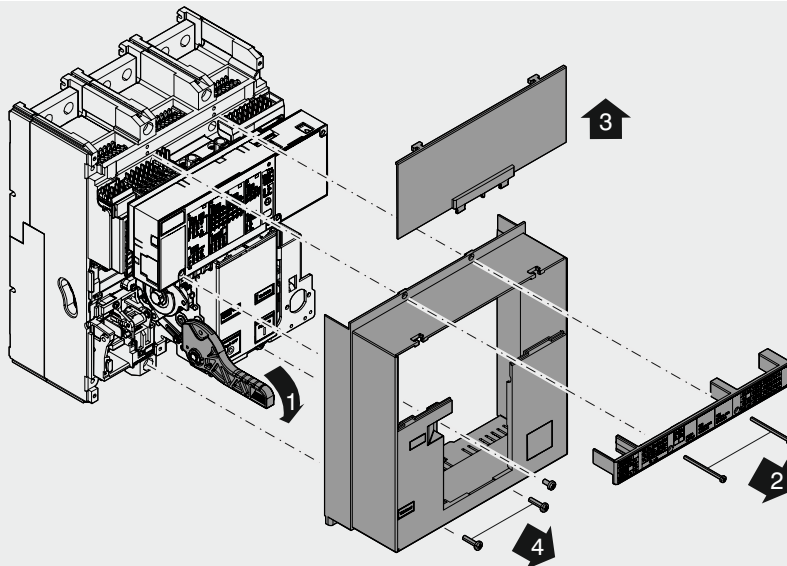
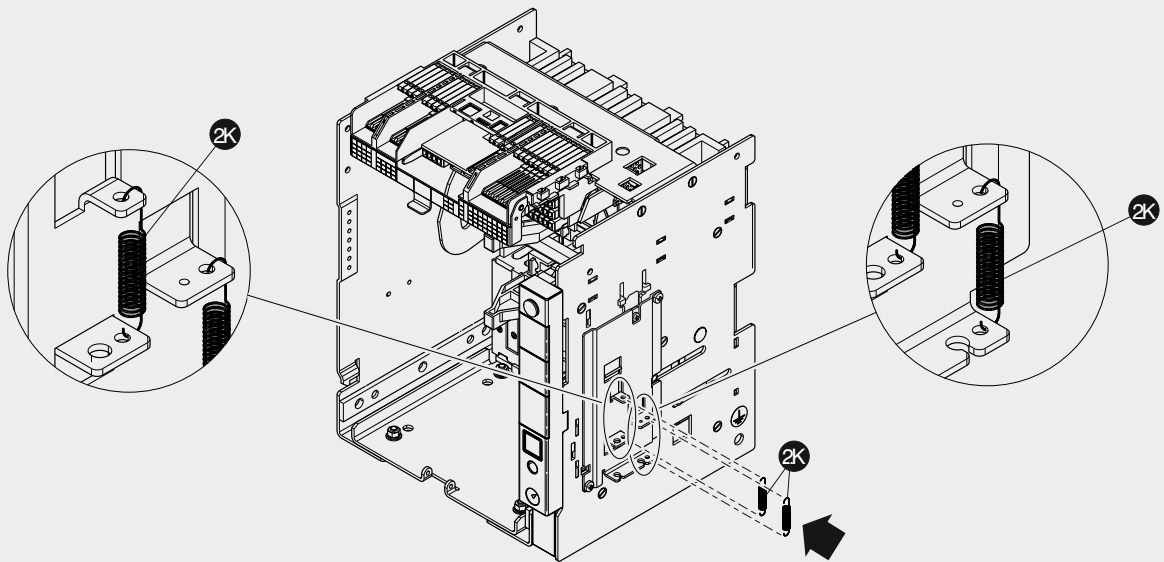

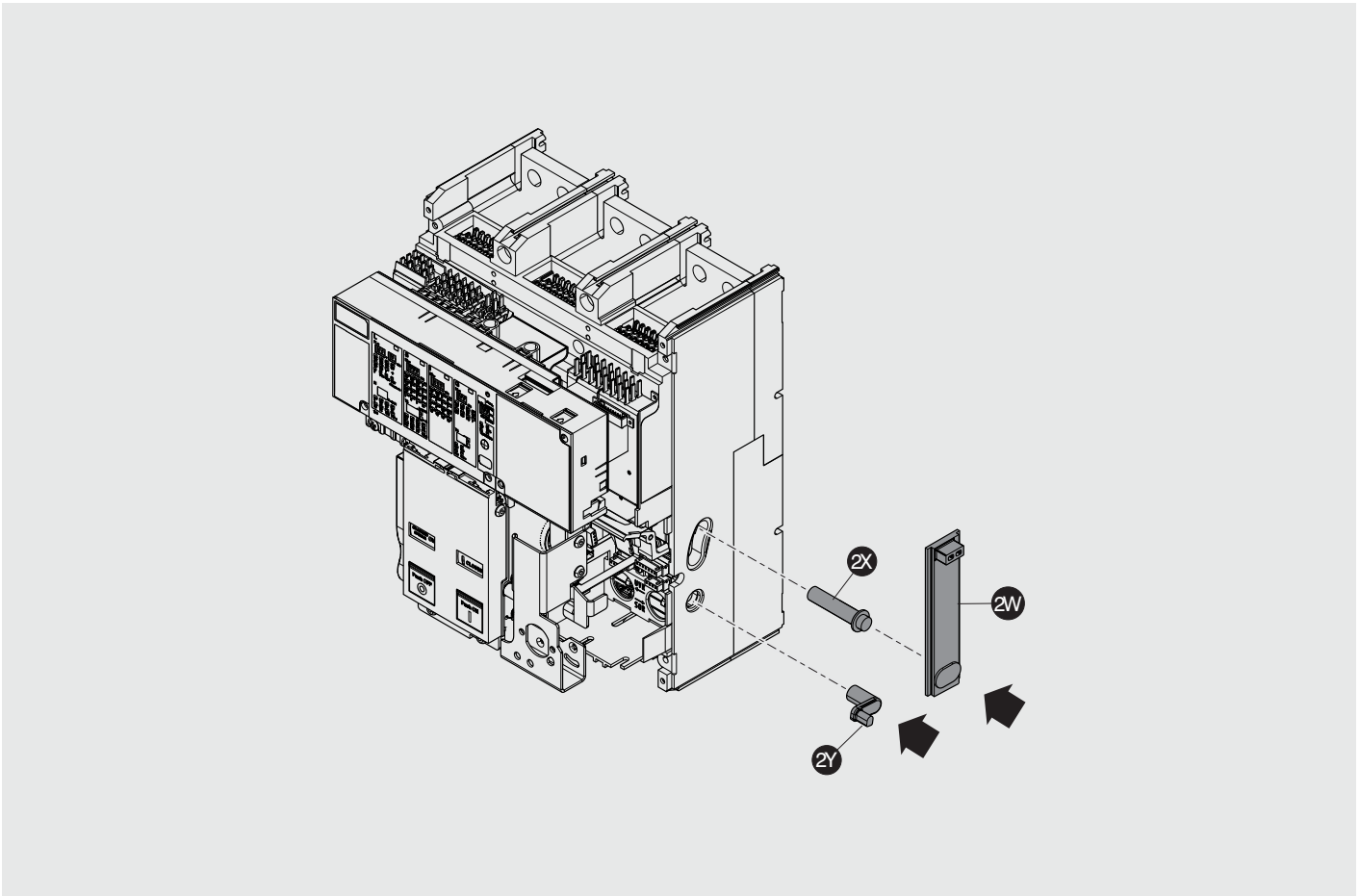
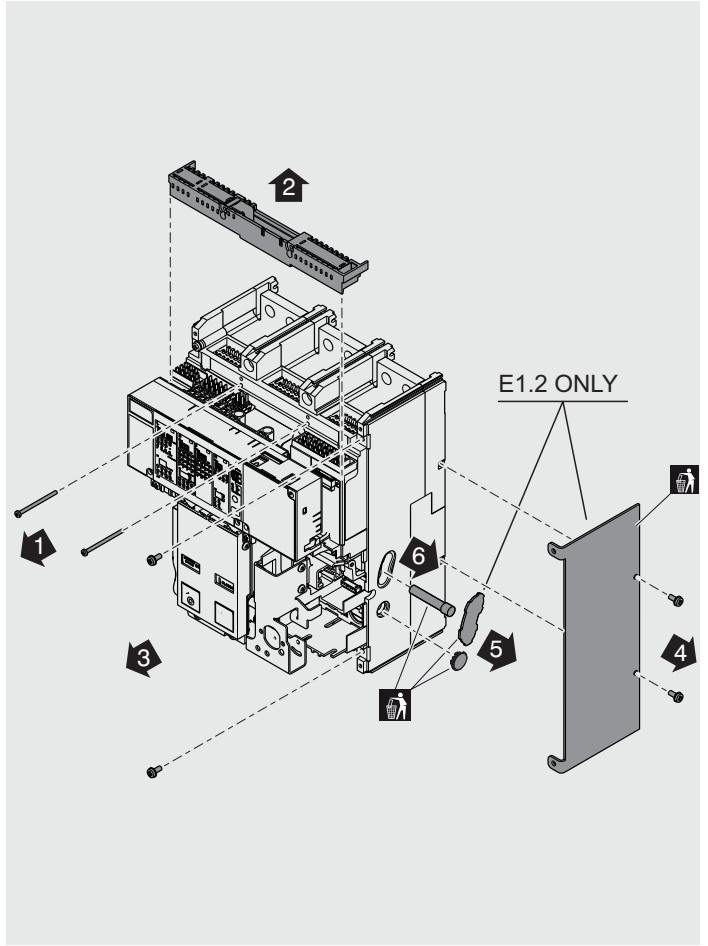
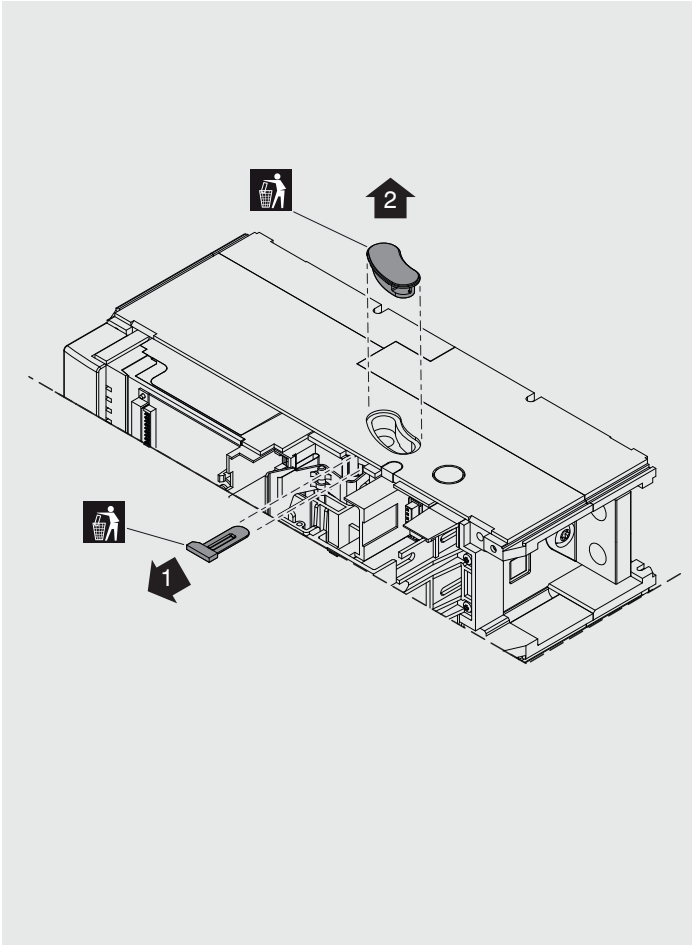

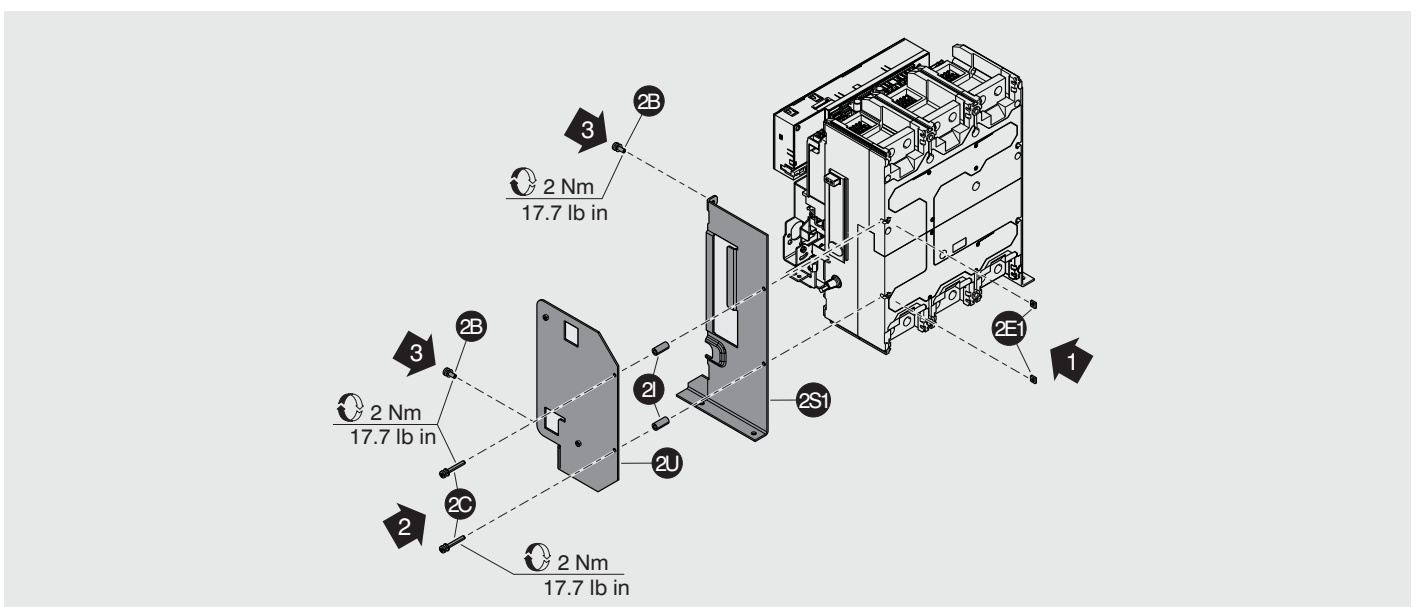
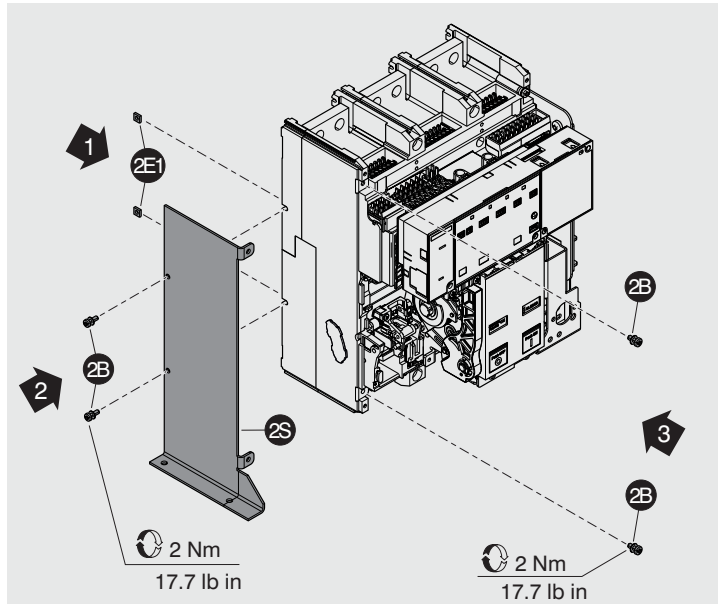
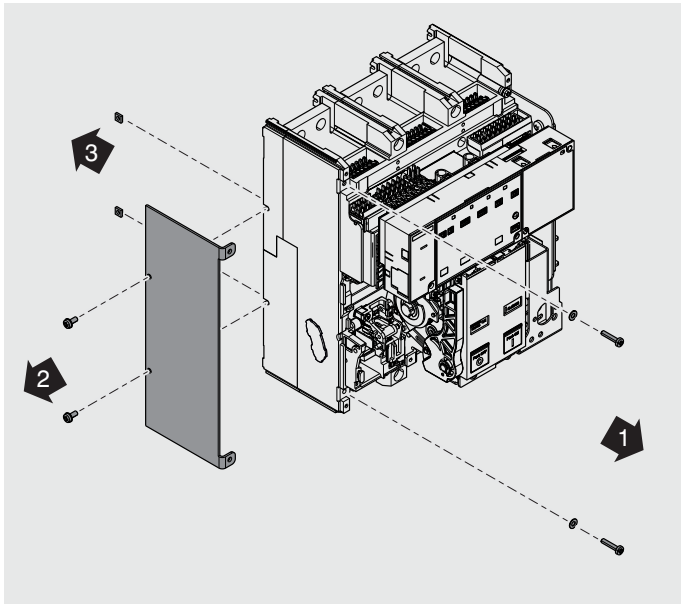
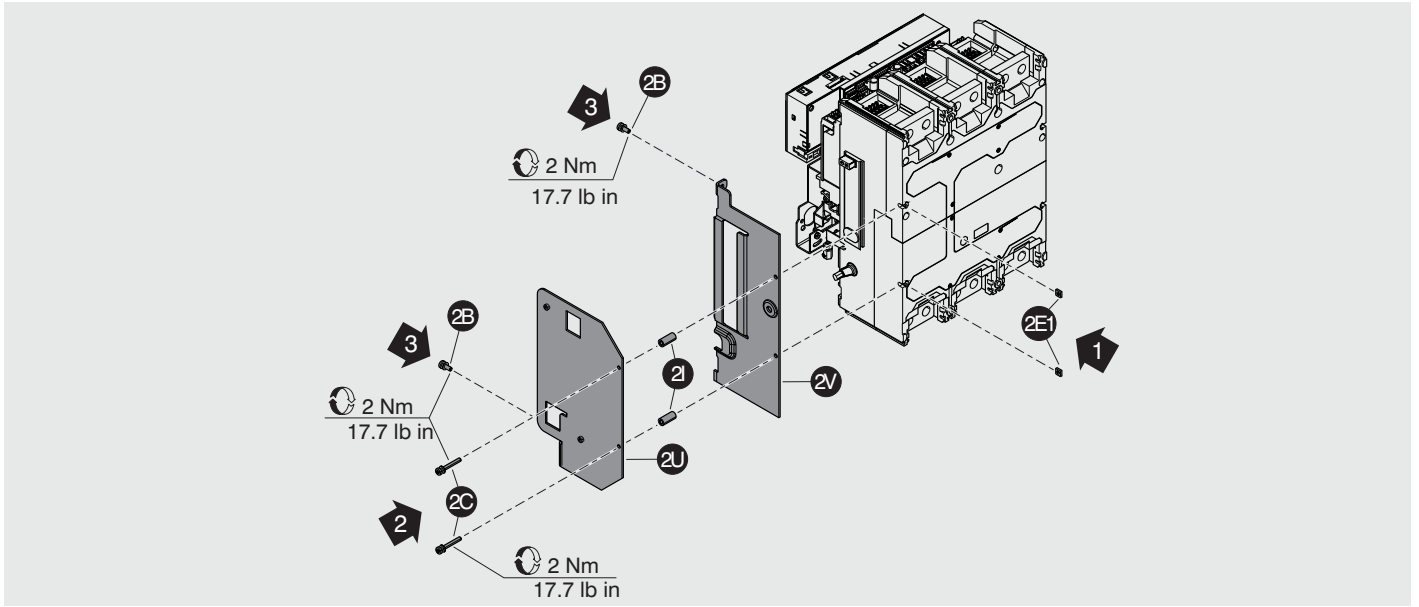

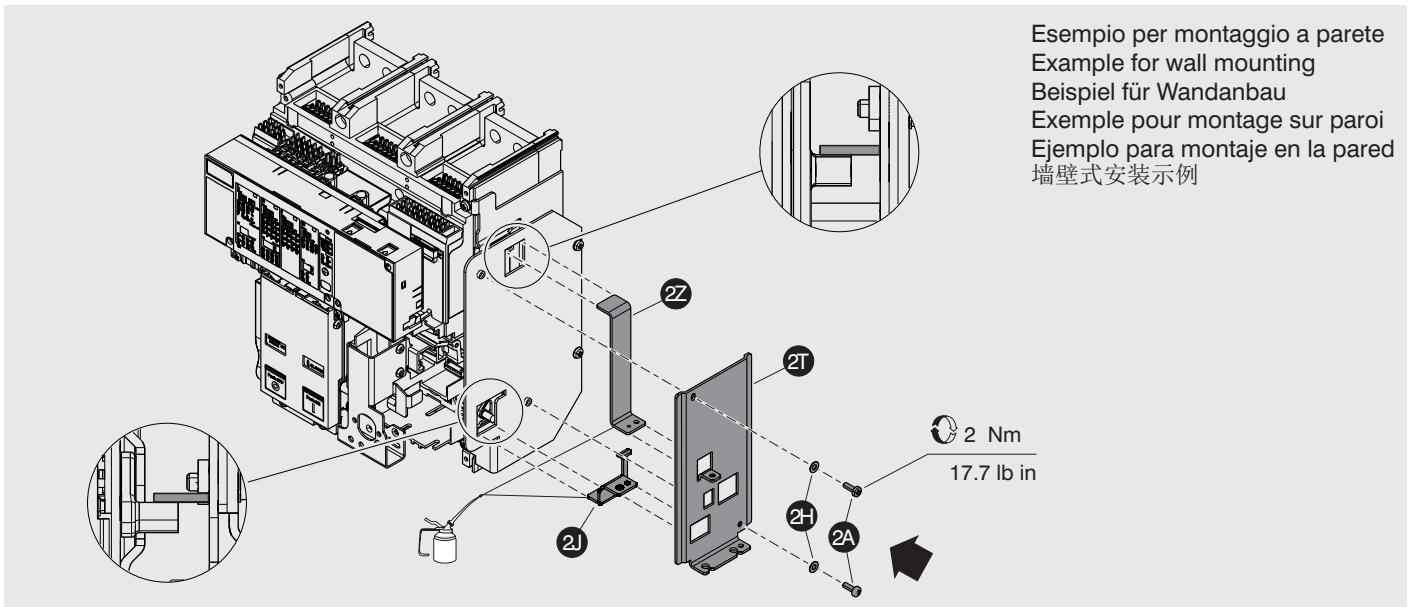

Esempio per montaggio a parete
 Example for wall mounting
 Beispiel für Wandanbau
 Exemple pour montage sur paroi
 Ejemplo para montaje en la pared
 墙壁式安装示例

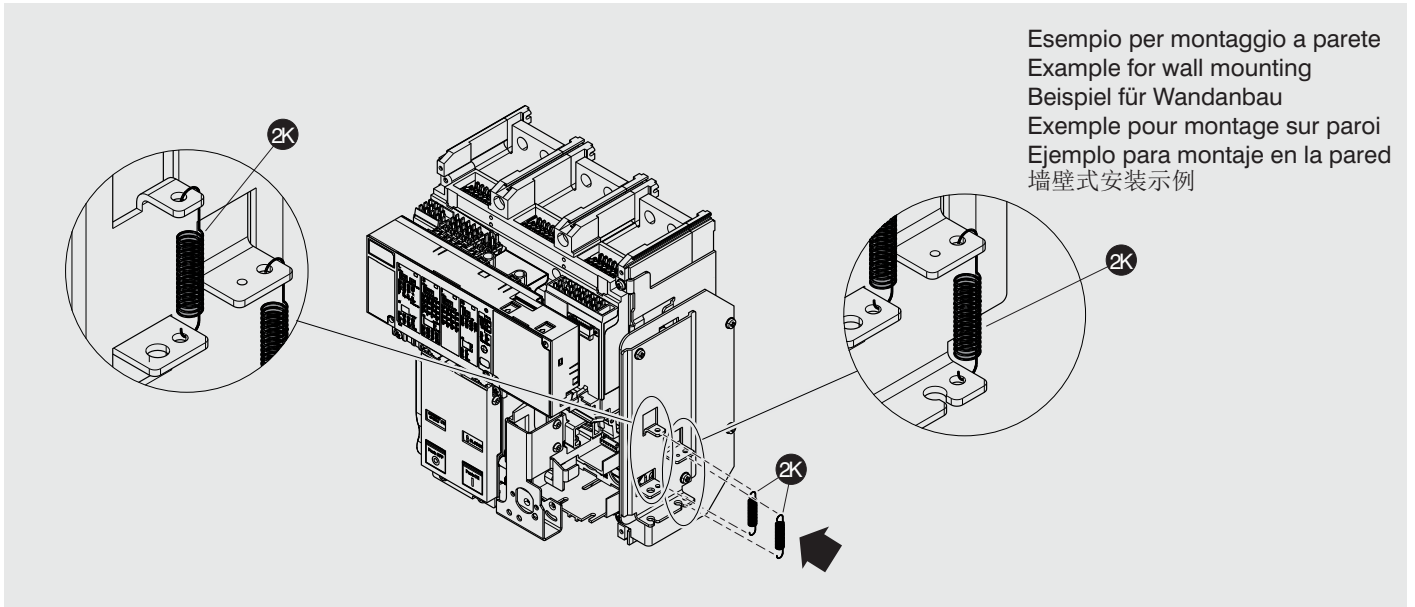

Esempio per montaggio a parete
 Example for wall mounting
 Beispiel für Wandanbau
 Exemple pour montage sur paroi
 Ejemplo para montaje en la pared
 墙壁式安装示例

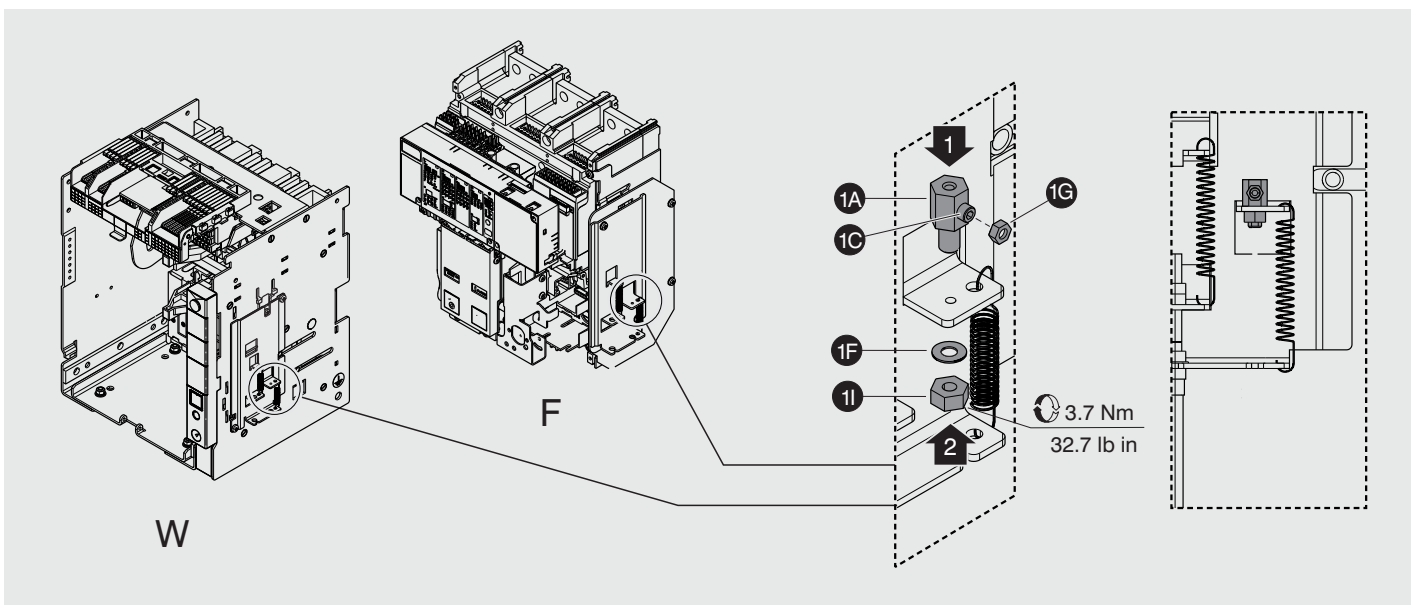

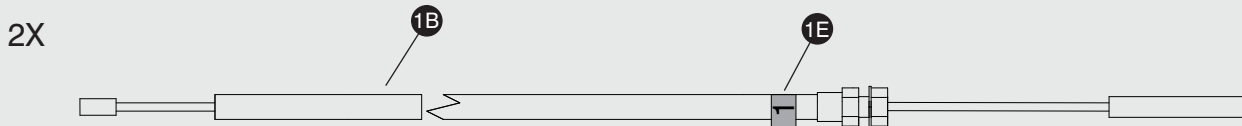

19

- Inserire i cavi nelle fascette come da schema sottostante.

- Nel fissare i cavi flessibili agli interruttori ridurre al minimo il numero delle curve (somma curve max 360°);
Le curve devono avere raggio min 70mm (min 2.76").

- Insert cables into the cable ties as shown in the diagram below.

- When attaching flexible cables to circuit-breakers, reduce the number of curves as much as possible (maximum sum of curves 360°);
The curves must have radius min 70mm (min 2.76").

- Die Kabel in die Kabelbinder einstecken, wie es im folgenden Schaltplan zu sehen ist.

- Bei der Befestigung der flexiblen Kabel an den Schaltgeräten die Anzahl von Kurven auf ein Minimum beschränken (Summer der Kurven max. 360°); Kurven müssen minimalen Radius 70mm (min 2.76").

- Passer les câbles dans les colliers comme dans le schéma ci-dessous.

- Lorsqu'on fixe les câbles flexibles sur les disjoncteurs, réduire au minimum le nombre de coudes (somme des coudes 360° maxi);
Courbes doivent avoir un rayon 70mm minimum (min 2.76").

- Introducir los cables en las bridas como se ve en el diagrama aquí abajo.

- Al fijar los cables flexibles a los interruptores, reducir al mínimo el número de codos (suma de codos máx. 360°);
Las curvas deben tener 70 mm de radio mínimo (min 2.76").

如下图所示，将电缆插入扎线带。

- 当连接柔性电缆至断路器时，应减少曲线数量（曲线总弧度最大 360°）。
曲线必须具有最小半径70 mm（min 2.76"）。

CB2

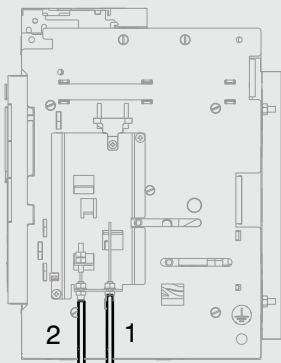

HORIZONTAL

- Posizionare i cavi sotto CB/parti fisse collegandoli al quadro mediante le fascette.
- Route cables below CB/fixe parts and fasten them to switchgear with cable ties.
- Die Kabel unten dem Leistungsschalter/den Festeilen positionieren und sie mittels Kabelbindern an der Schaltanlage anschließen.
- Positionner les câbles dessous le Disjoncteur/parties fixes en le branchant au tableau à l'aide de colliers.
- Posicionar los cables por debajo interruptor/partes fijas conectándolos al cuadro mediante las bridas.
- 将电缆布设在CB/固定部件下方，并使用扎线带将其固定在开关柜上。

CB1

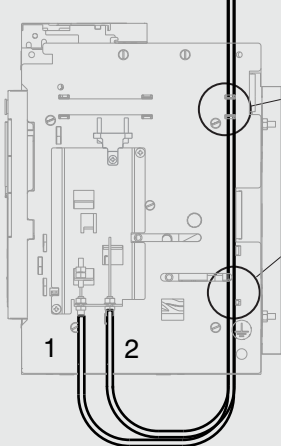

OK!

1D

CB1

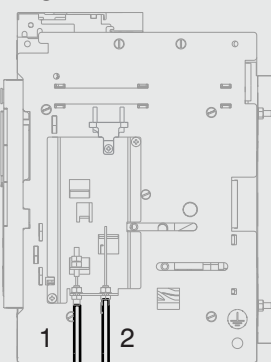

CB2

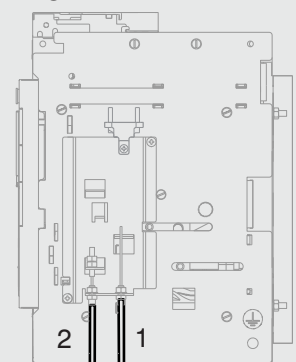

OK!

1D

2X

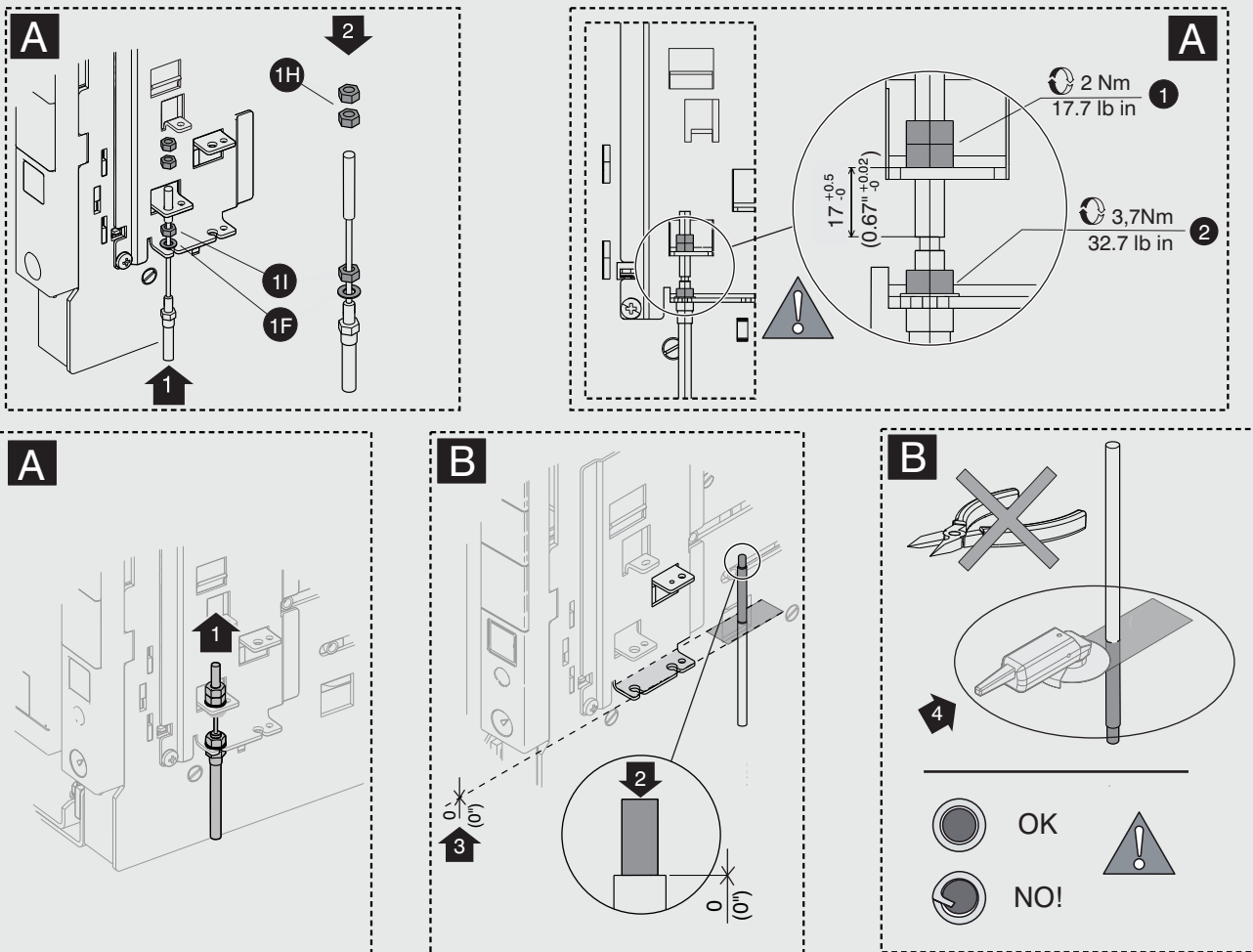
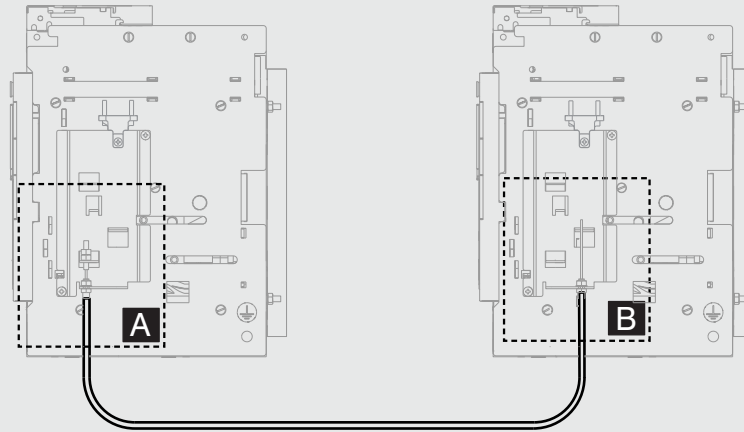

- Tirare il cavo nella guaina come indicato dalla freccia 1 (A) fino a che il puntale dalla parte opposta (B) va in battuta sulla guaina come indicato dalla freccia 2 e segnare il cavo per il taglio, in corrispondenza del piano indicato dalla freccia 3 e tagliare come mostrato dalla freccia 4.

- Pull cable into sheath as shown by arrow 1 until tip from opposite side comes up against the sheath as shown by arrow 2. Mark cable for cutting on a level with the plane indicated by arrow 3, then cut as shown by arrow 4.

- Das Kabel wie von Pfeil 1 angegeben in der Hülle ziehen, bis die Spitze von der Gegenseite her zum Anschlag auf der Hülle gelangt, wie es von Pfeil 2 angegeben wird, und das Kabel auf der Höhe der Ebene, die von Pfeil 3 angezeigt wird, zum Schneiden vorbereiten und wie von Pfeil 4 gezeigt durchschneiden.

- Tirer le câble dans la gaine comme indiqué par la flèche 1 jusqu'à ce que l'embout de la partie opposée aille en butée comme indiqué par la flèche 2 et marquer le câble pour la coupe, au niveau du plan indiqué par la flèche 3 et couper comme montré par la flèche 4.

- Tirar del cable en la funda como indica la flecha 1 hasta que la punta de la parte opuesta toque con la funda como indica la flecha 2; marcar el cable para el corte, en correspondencia con el plano indicado por la flecha 3; cortar como muestra la flecha 4.

- 如箭头1所示，将电缆拉入屏蔽层，直到另一侧端部倚靠到屏蔽层，如箭头2所示。在电缆上标记用于在水平面上切割使用箭头3所示的平面，随后根据箭头4所示进行切割。

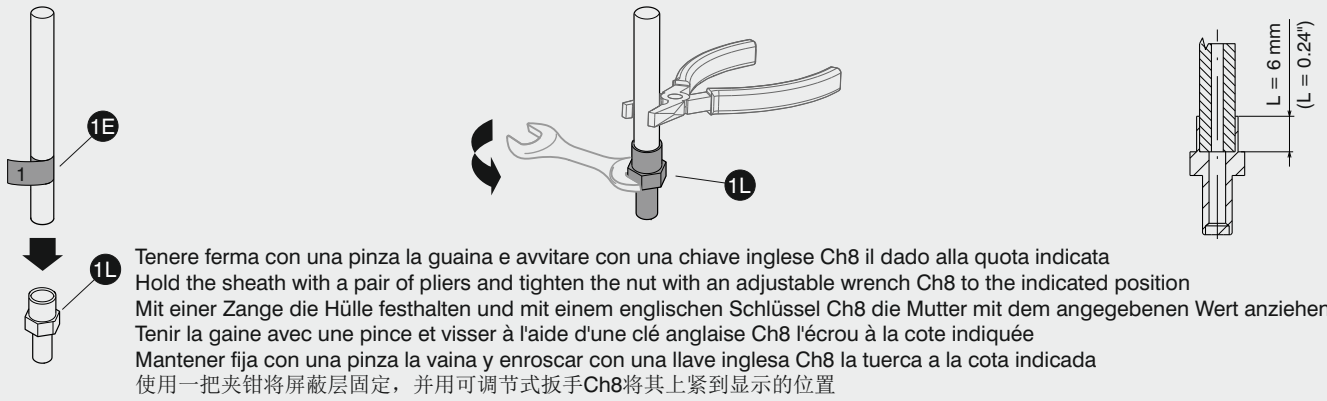

Tenere ferma con una pinza la guaina e avvitare con una chiave inglese Ch8 il dado alla quota indicata
 Hold the sheath with a pair of pliers and tighten the nut with an adjustable wrench Ch8 to the indicated position
 Mit einer Zange die Hülle festhalten und mit einem englischen Schlüssel Ch8 die Mutter mit dem angegebenen Wert anziehen
 Tenir la gaine avec une pince et visser à l'aide d'une clé anglaise Ch8 l'écrou à la cote indiquée
 Mantener fija con una pinza la vaina y enroscar con una llave inglesa Ch8 la tuerca a la cota indicada
 使用一把夹钳将屏蔽层固定，并用可调节式扳手Ch8将其上紧到显示的位置

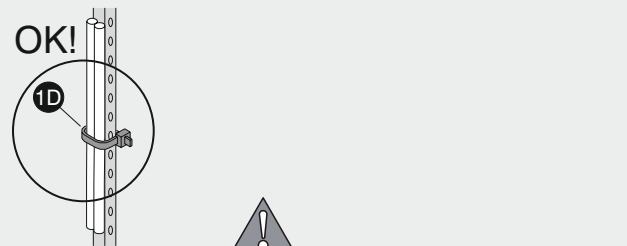
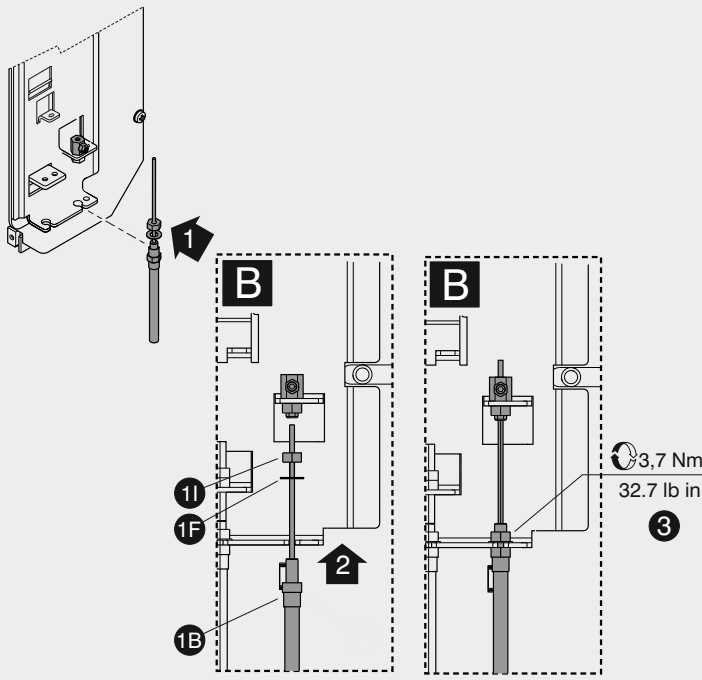

ATTENZIONE: Stringere le fascette per assicurarsi che la forma dei cavi non possa essere modificata dopo la regolazione.

WARNING: Tighten the bands to make sure that the shape of the cables can not be changed after adjusting.

HINWEISE: Ziehen Sie die Schellen fest, um sicherzustellen, dass die Form der Kabel nach der Einstellung nicht verändert werden kann.

REMARQUES: Serrez les collier de serrage pour vous assurer que la forme des câbles ne peut pas être changée après le réglage.

NOTAS: Apriete los abrazaderas para asegurarse de que la forma de los cables no se puede cambiar después de la regulación.

警告：紧固束带，确保完成调节后电缆形态不会出现变化。

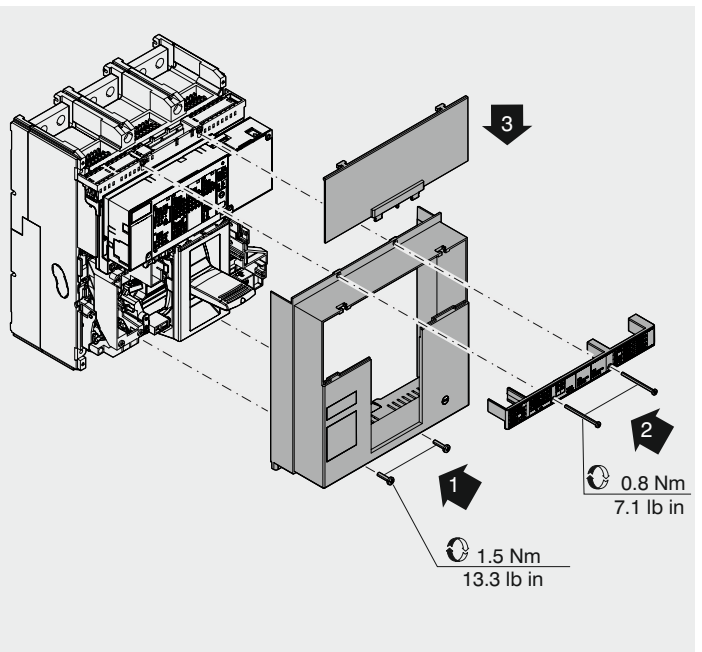
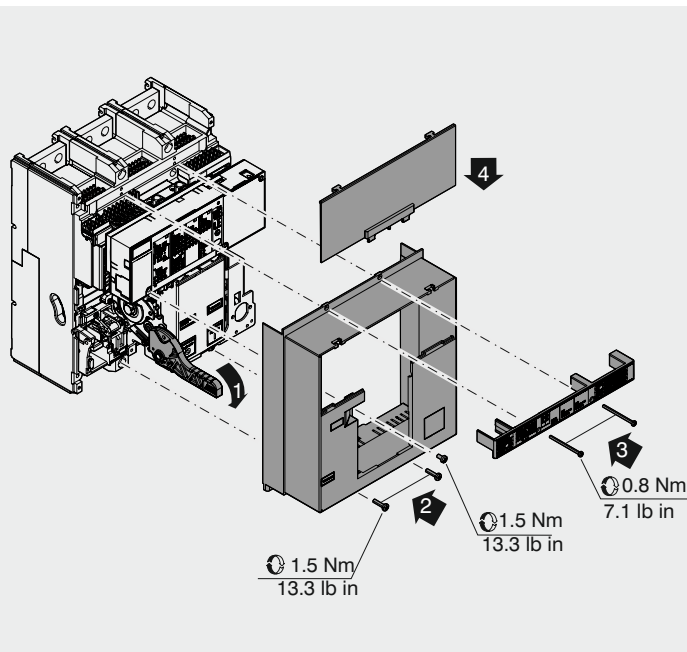

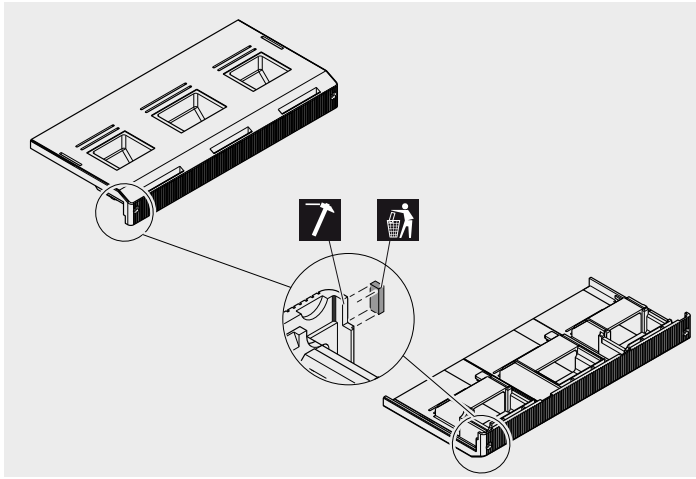
**REGOLAZIONE:**

N.B. Nelle regolazioni quando si agisce sui dadi non far ruotare su sé stessi i puntali dei cavi

- 1 Inserire le parti mobili nelle parti fisse (se estraibili)
- 2 Chiudere l'interruttore "CB1"
- 3.1 Tirare il cavo "Y2" dell'interruttore chiuso verso l'alto fino a portare il tirante "Y4" dell'interruttore aperto in leggera battuta sul piano "Y3"
- 3.2 Bloccare il grano "Y1" (1.5 Nm / 13.3 lb in) e chiudere il relativo controdado "Y5" (1.5 Nm / 13.3 lb in)
- 4 Aprire l'interruttore "CB1"
- 5 Chiudere l'interruttore "CB2" e ripetere i punti 3.1 e 3.2
- 6 Aprire l'interruttore "CB2"
- 7 Eseguire alcune manovre di chiusura e apertura, quindi verificare la battuta dei tiranti "Y4" sul piano "Y3"
- 8 Aprire l'interruttore chiuso

ADJUSTMENT:

N.B. During adjustments, when tightening or loosening the nuts do not allow the tips of the cables to rotate on themselves

- 1 Fit moving parts into fixed parts (if withdrawable)
- 2 Close circuit-breaker "CB1"
- 3.1 Pull cable "Y2" of the closed circuit-breaker upwards until the tie rod "Y4" of the open circuit-breaker touches slightly against the surface "Y3"
- 3.2 Lock the grub screw M4 "Y1" (1.5 Nm / 13.3 lb in) and close the corresponding lock nut (1.5 Nm / 13.3 lb in)
- 4 Open circuit-breaker "CB1"
- 5 Close circuit-breaker "CB2" and repeat steps 3.1 e 3.2
- 6 Open circuit breaker "CB2"
- 7 Perform a few opening and closing operations, than check that the tie rods "Y4" are touching against the surface "Y3"
- 8 Open closed circuit-breaker

EINSTELLUNG:

Anm.: Bei den Einstellungen, wenn man die Muttern dreht, die Klemmen der Kabel nicht auf sich selbst drehen lassen

- 1 Die beweglichen Teile in die festen Teile (sofern ausziehbar) einfahren
- 2 Den Leistungsschalter "CB1" einschalten
- 3.1 Das Kabel "Y2" des eingeschalteten Leistungsschalters nach oben ziehen, bis der Zuganker "Y4" des ausgeschalteten Leistungsschalters in leichten Anschlag auf der Fläche "Y3" gebracht wird
- 3.2 Die Madenschraube M4 "Y1" (1.5 Nm / 13.3 lb in) blockieren und die entsprechende Gegenmutter (1.5 Nm / 13.3 lb in) schließen
- 4 Den Leistungsschalter "CB1" ausschalten
- 5 Den Leistungsschalter "CB2" einschalten und die Punkte 3.1 und 3.2 wiederholen
- 6 Den Leistungsschalter "CB2" ausschalten
- 7 Ein paar Ein- und Ausschaltungen ausführen, dann den Anschlag der Zuganker "Y4" auf der Fläche "Y3" prüfen
- 8 Den eingeschalteten Leistungsschalter öffnen

RÉGLAGE:

N.B. Dans les réglages, lors de l'action sur les écrous, ne pas faire tourner sur eux-mêmes les embouts des câbles

- 1 Introduire les parties mobiles dans les parties fixes (si débrochables)
- 2 Fermer le disjoncteur "CB1"
- 3.1 Tirer le câble "Y2" du disjoncteur fermé vers le haut jusqu'à mettre le tirant "Y4" du disjoncteur ouvert légèrement en butée contre le plan "Y3"
- 3.2 Bloquer la vis sans tête M4 "Y1" (1.5 Nm / 13.3 lb in) et serrer le contre-écrou (1.5 Nm / 13.3 lb in)
- 4 Ouvrir le disjoncteur "CB1"
- 5 Fermer le disjoncteur "CB2" et répéter les points 3.1 et 3.2
- 6 Ouvrir le disjoncteur "CB2"
- 7 Effectuer quelques manœuvres de fermeture et d'ouverture, puis vérifier la butée des tirants "Y4" sur le plan "Y3"
- 8 Ouvrir le disjoncteur fermé

REGULACIÓN:

NOTA: En las regulaciones cuando se opera con las tuercas no hacer girar sobre sí mismos los terminales de los cables

- 1 Introducir las partes móviles en las partes fijas (si son extraíbles)
- 2 Cerrar el interruptor "CB1"
- 3.1 Tirar del cable "Y2" del interruptor cerrado hacia arriba hasta llevar el tirante "Y4" del interruptor abierto apenas tocando sobre la superficie "Y3"
- 3.2 Bloquear el pasador M4 "Y1" (1.5 Nm / 13.3 lb in) y ajustar la correspondiente contratuerca (1.5 Nm / 13.3 lb in)
- 4 Abrir el interruptor "CB1"
- 5 Cerrar el interruptor "CB2" y repetir los puntos 3.1 y 3.2
- 6 Abrir el interruptor "CB2"
- 7 Efectuar algunas maniobras de cierre y apertura, luego verificar que los tirantes "Y4" hagan tope sobre la superficie "Y3"
- 8 Abrir el interruptor cerrado

调节:

备注 在调节过程中, 当紧固或松开螺母无法使电缆端子自行旋转时

- 1 件移动部件安装到固定部件 (如可抽出)
- 2 将断路器闭合 "CB1"
- 3.1 向上拉动已闭合断路器的电缆 "Y2" 直到已断开的断路器横拉杆 "Y4" 略微触碰到表面 "Y3"
- 3.2 将沉头螺钉 M4 "Y1" (1.5 Nm / 13.3 lb in) 锁止并闭合相应的锁紧螺母 (1.5 Nm / 13.3 lb in)
- 4 断开断路器 "CB1"
- 5 闭合断路器 "CB2" 并重复操作步骤 3.1 和 3.2
- 6 断开断路器 "CB2"
- 7 执行若干断开和闭合操作, 随后检查横拉杆 "Y4" 是否触碰到表面 "Y3"
- 8 断开已闭合的断路器

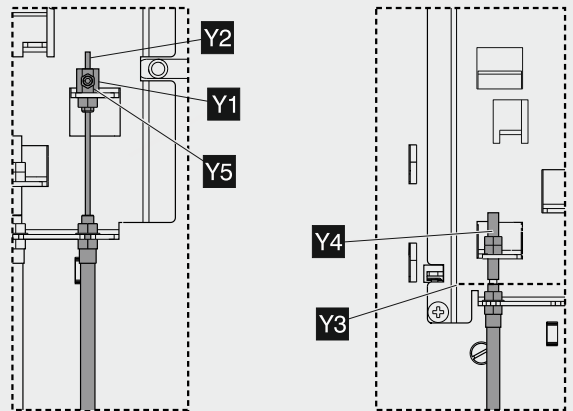

CONTROLLO MECCANICO:

Riarmare le molle dei comandi degli interruttori ed eseguire le seguenti operazioni:

- 1- Chiudere l'interruttore "CB1" e controllare che l'interruttore "CB2" non possa essere chiuso.
Riarmare le molle del comando dell'interruttore "CB1"
verificando che lo stesso resti in chiuso, quindi aprire l'interruttore "CB1".
- 2- Chiudere l'interruttore "CB2" e controllare che l'interruttore "CB1" non possa essere chiuso.
Riarmare le molle del comando dell'interruttore "CB2"
verificando che lo stesso resti in chiuso, quindi aprire l'interruttore "CB2".
- 3- Ripetere il test per tre volte. Al termine dei test verificare le regolazioni e il bloccaggio dei tiranti.

MECHANICAL CHECK:

Reset the springs of the operating mechanisms of the circuit-breakers and perform the following operations:

- 1- Close circuit-breaker "CB1" and make sure that circuit-breaker "CB2" cannot be closed.
Reset the springs of circuit-breaker "CB1" operating mechanism,
checking that the circuit-breaker remains closed, then open circuit-breaker "CB1".
- 2- Close circuit-breaker "CB2" and make sure that circuit-breaker "CB1" cannot be closed.
Reset the springs of circuit-breaker "CB2" checking that the
circuit-breaker remains closed, then open circuit-breaker "CB2".
- 3- Repeat the test three times. When the tests are completed check the adjustments and the locking of the tie rods.

MECHANISCHE KONTROLLE:

Die Federn der Antriebe der Leistungsschalter rückstellen und die folgenden Vorgänge ausführen:

- 1- Den Leistungsschalter "CB1" einschalten und sicherstellen, dass der Leistungsschalter "CB2" nicht eingeschaltet werden kann.
Die Federn des Antriebs von Leistungsschalter "CB1" rückstellen und sicherstellen, dass er eingeschaltet bleibt,
dann den Leistungsschalter "CB1" ausschalten.
- 2- Den Leistungsschalter "CB2" einschalten und sicherstellen, dass der Leistungsschalter "CB1" nicht eingeschaltet werden kann.
Die Federn des Antriebs von Leistungsschalter "CB2" rückstellen und sicherstellen,
dass er eingeschaltet bleibt, dann den Leistungsschalter "CB2" ausschalten.
- 3- Den Test drei Mal wiederholen. Am Ende des Tests die Einstellungen und den festen Sitz der Zuganker sicherstellen.

CONTROLE MÉCANIQUE:

Réarmer les ressorts des commandes des disjoncteurs et effectuer les opérations suivantes:

- 1- Fermer le disjoncteur "CB1" et contrôler que le disjoncteur "CB2" ne puisse pas être fermé.
Réarmer les ressorts de la commande du disjoncteur "CB1"
en vérifiant que celui-ci reste en fermé, puis ouvrir le disjoncteur "CB1".
- 2- Fermer le disjoncteur "CB2" et contrôler que le disjoncteur "CB1" ne puisse pas être fermé.
Réarmer les ressorts de la commande du disjoncteur "CB2"
en vérifiant que celui-ci reste en fermé, puis ouvrir le disjoncteur "CB2".
- 3- Répéter le test trois fois. A la fin des tests vérifier les réglages et le blocage des tirants.

CONTROL MECÁNICO:

Rearmar los resortes de los mandos de los interruptores y efectuar las siguientes operaciones:

- 1- Cerrar el interruptor "CB1" y controlar que no pueda cerrarse el interruptor "CB2".
Rearmar los resortes del mando del interruptor "CB1"
verificando que el mismo quede cerrado, luego abrir el interruptor "CB1".
- 2- Cerrar el interruptor "CB2" y controlar que no pueda cerrarse el interruptor "CB1".
Rearmar los resortes del mando del interruptor "CB2"
verificando que el mismo quede cerrado, luego abrir el interruptor "CB2".
- 3- Repetir el test tres veces. Al finalizar las pruebas verificar las regulaciones y el bloqueo de los tirantes.

机械性能检查:

重置断路器操作机构的弹簧, 并进行以下操作:

- 1- 闭合断路器 "CB1" 并确保断路器 "CB2" 无法闭合。重置断路器 "CB1" 操作机构的弹簧, 检查断路器是否保持闭合, 然后开启断路器 "CB1"
- 2- 闭合断路器 "CB2" 并确保断路器 "CB1" 无法闭合。重置断路器 "CB2" 操作机构的弹簧, 检查断路器是否保持闭合, 然后开启断路器 "CB2"
- 3- 重复测试三次。当测试完成后, 检查调节设置和横拉杆的锁止情况。

Eseguire le operazioni di manutenzione della figura 31 secondo le modalità indicate nella figura 30
Perform maintenance operations of figure 31 according to the procedures indicated in the figure 30
Die Wartungsvorgänge nach den Modalitäten ausführen der Abb. 31 und die in der Abb. 30
Exécuter les opérations de maintenance des la figure 31 selon les modalités indiquées dans la figure 30
Efectuar las tareas de mantenimiento de las figuras 31 siguiendo las modalidades indicadas en las figuras 30
按照图 31 中的说明进行如图 30 所示的定期维护





ATTENZIONE: gli interblocchi non possono essere verificati nelle posizioni Test o Estratto
WARNING: the interlocks cannot be tested in the Test or Disconnected positions
ACHTUNG: Die Verriegelungen können in der Test- oder Außenstellung nicht geprüft werden
ATTENTION: les verrouillages ne peuvent pas être vérifiés dans les positions Test ou Débrouché
ATENCIÓN: los enclavamientos no pueden ser controlados en las posiciones Prueba o Extraído
警告 在测试或断开位置时 无法测试联锁机构的有效性

Attività	Frequenza	Azioni di manutenzione
Funzionalità	Un anno o 20% della vita meccanica o 20% della vita elettrica	Vedi paragrafo: Controllo Meccanico
Controllo di serraggio		Vedi foglio kit
Lubrificazione		Applicare dove è presente  nel foglio kit e dove mostrato nelle figure seguenti
Cavi	- Tre anni o 50% della vita meccanica or 50% della vita elettrica dell'interruttore di taglia maggiore coinvolto nell'interblocco - Dopo un intervento a seguito di corto circuito	Consigliata la sostituzione

Activity	Frequency	Maintenance Action
Functionality	One year or 20% of mechanical life or 20% of electrical life	See paragraph: Mechanical check
Tightening check		See kit sheet
Lubrification		To be applied where  is present in the kit sheet and where shown in the figure below
Cables	- Three years or 50% of mechanical life or 50% of electrical life of the higher frame breaker involved in the interblock - After a trip due to a short-circuit	Replacement is suggested

Tätigkeit	Frequenz	Wartungsvorgänge
Funktionen	Ein Jahr oder 20% der mechanischen Lebensdauer oder 20% der elektrischen Lebensdauer	Siehe Abschnitt: Mechanische Kontrolle
Kontrolle des Anzugsmoments		Siehe das Blatt von Bausatz
Schmierung		Anzuwenden dort, wo es  im Bausatzblatt angegeben ist und wo es in der Abbildung unten dargestellt ist.
Kabel	- Drei Jahre oder 50% der mechanischen Lebensdauer oder 50% der elektrischen Lebensdauer des größten Leistungsschalters, der mit der Verriegelung verbunden ist - Nach einem Eingriff infolge eines Kurzschlusses	Der Austausch ist zu empfehlen

Activité	Frequence	Actions de maintenance
Fonctionnalités	Un an ou 20% de l'endurance mécanique ou 20% de l'endurance électrique	Voir paragraphe: Contrôle mécanique
Contrôle de serrage		Voir la fiche kit
Lubrification		Appliquer aux endroits  indiqués sur la fiche du kit et aux endroits indiqués sur la figure ci-dessous.
Câbles	- Trois ans ou 50% de l'endurance mécanique ou 50% de l'endurance électrique du disjoncteur de taille supérieure impliqué dans le verrouillage - Après une intervention à la suite d'un court-circuit	Le remplacement est conseillé

Actividad	Frecuencia	Acciones de mantenimiento
Funcionalidades	Un año o 20% de la vida mecánica o 20% de la vida eléctrica	Véase el apartado: Control mecánico
Control de apriete		Véase la hoja kit
Lubrificación		Se aplica donde esté  presente en la hoja del kit y donde se muestra en la figura a continuación.
Cables	- Tres años o 50% de la vida mecánica o 50% de la vida eléctrica del interruptor de mayor tamaño implicado en el enclavamiento - Después de una actuación por cortocircuito	Aconsejada la sustitución

活动	频率	维护操作
设备功能性	1年或 20%的机械寿命或 20%的电气寿命	参见段落：机械检查
检查密封性		查看套件表
润滑性		适用于套件表中所示位置  以及下图所示位置。
电缆	- 三年或50%的机械寿命或50%的电气寿命或最大的断路器联锁 - 短路引起的一次脱扣之后	建议更换

