

Motorized switch fuses OSM_ Installation and operating instructions

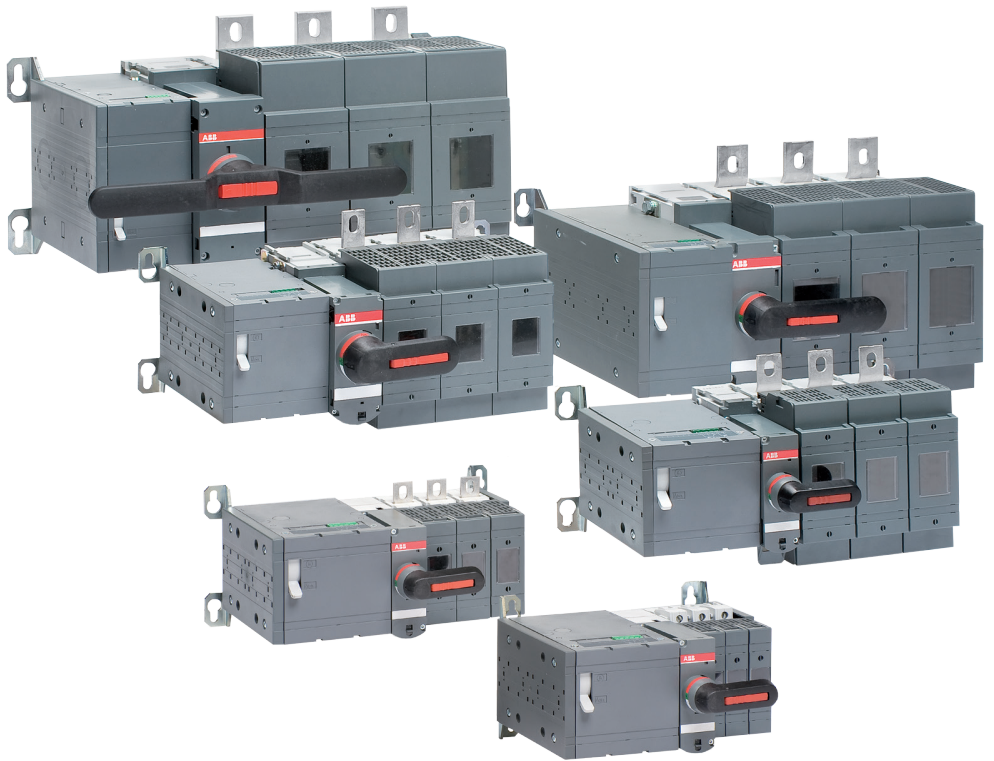



Contents

- 1. Introduction..... 4
- 1.1 Use of symbols..... 4
- 1.2 Explanations of abbreviations and terms 4
- 2. Product overview 5
- 3. Quick start 6
- 3.1 Operating the motorized switch fuse electrically; remote control 6
- 3.1.1 Locking electrical control..... 6
- 3.2 Operating the motorized switch fuse manually; local operation..... 7
- 4. Installation..... 8
- 4.1 Mounting the motorized switch fuse 8
- 4.2 Dimensional drawings..... 10
- 4.3 Mounting positions 14
- 4.4 Labelling 14
- 5. Connecting 15
- 5.1 Control circuit 15
- 6. Operating..... 16
- 6.1 Electrical operation 16
- 6.1.1 Impulse control 17
- 6.1.2 Continuous control 18
- 6.2 Manual operation using the handle 18
- 6.3 Locking 19
- 6.3.1 Locking the electrical operation 19
- 6.3.2 Locking the manual operation 20
- 7. Technical data..... 22
- 8. Accessories 23
- 8.1 Fuse links..... 23
- 8.2 Terminal clamp sets 25
- 8.3 Terminal shrouds..... 26
- 8.4 Auxiliary contacts 27
- 8.4.1 Mounting of auxiliary contacts..... 27
- 8.4.2 Mounting of Test auxiliary contacts 27
- 8.5 Neutral links 30
- 8.6 Fuse monitors 32
- 8.7 Blown fuse indicators 33
- 8.8 Handle and spare fuse storage..... 36
- 9. UL standard switches 37

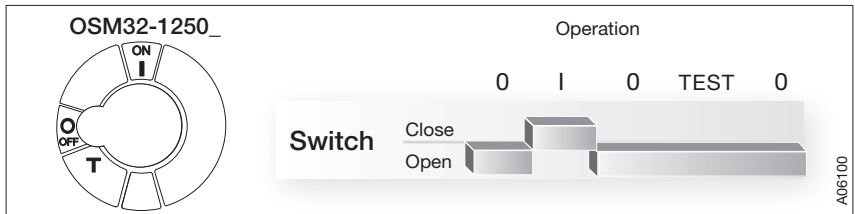

1. Introduction

This manual describes the installation and the basic operation of the motorized switch fuses, types OSM_. The instructive part is followed by a section on available accessories.

1.1 Use of symbols



Hazardous voltage: warns about a situation where a hazardous voltage may cause physical injury to a person or damage to equipment.



General warning: warns about a situation where something other than electrical equipment may cause physical injury to a person or damage to equipment.



Caution: provides important information or warns about a situation that may have a detrimental effect on equipment.



Information: provides important information about the equipment.

1.2 Explanations of abbreviations and terms

OSM_:	Motorized switch fuse, the type name
OME_:	Motor operator, the type name
OS_:	Switch fuse, the type name
OSM_N3:	Motorized switch fuse with a neutral link integrated into the mechanism, the type name
DIN, BS, J and L types:	Different types of fuse links, accessories
OZXB_ and OZXA_:	Terminal clamp sets, the type name, accessories
OSS_ and OTS_:	Terminal shrouds, the type name, accessories
OA_:	Auxiliary contacts, the type name, accessories
OXN_:	Neutral links (detachable), the type name, accessories
OSGD_ and OSZX3/4:	Blown fuse indicators (DPMM), the type name, accessories
OFS_:	Fuse monitors, the type name, accessories
OFMZX_:	Crimp terminals for mounting the fuse monitors, the type name, accessories
OTVS_:	Mounting accessory for handle and spare fuse storing, the type name, accessories

2. Product overview

Motorized switch fuses (type OSM_) are suitable for remote control. You can operate the motorized switch fuses either electrically by using the motor operator or manually by using the handle. The operation, either electrical or manual, can be chosen by the selector switch "Motor/Manual" on the motor operator. Motorized switch fuses consist of the switch fuse and the motor operator.

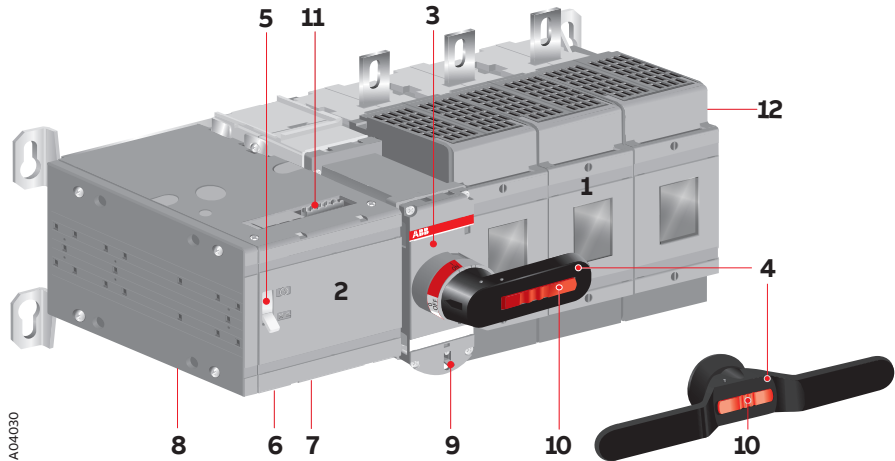

Figure 2.1 Motorized switch fuse (type OSM)

- 1 Switch fuse
- 2 Motor operator
- 3 Switch panel, the operating mechanism
- 4 Handle for manual operation, double grip handle in sizes OSM1250_
- 5 Motor/Manual selection
- 6 Terminals for motor operator voltage supply
- 7 Terminals for push-buttons
- 8 Fuse (F1) of motor operator
- 9 Locking latch for releasing the handle and locking electrical operation
- 10 Locking clip for locking manual operation
- 11 Terminals for locking state information
- 12 Place for auxiliary contacts

3.2 Operating the motorized switch fuse manually; local operation

To operate the motorized switch fuse manually:

1. Turn the Motor/Manual selector to the Manual (Man.) position to enable manual operation and to prevent electrical operation.
2. Attach the handle to the switch panel. You can attach the handle in both positions (I or 0).

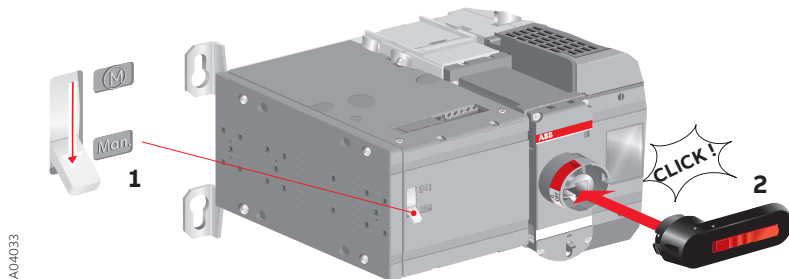

Figure 3.3 Operating the motorized switch fuse manually

To disable the manual (and at the same time also electrical) operation, lift up the locking clip to position 0 and attach the padlock to the handle.

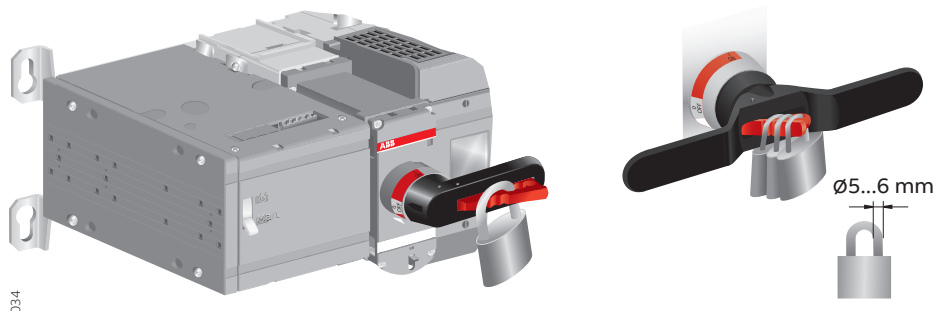

Figure 3.4 Locking the manual operation

4. Installation

4.1 Mounting the motorized switch fuse



Use protection against direct contact.

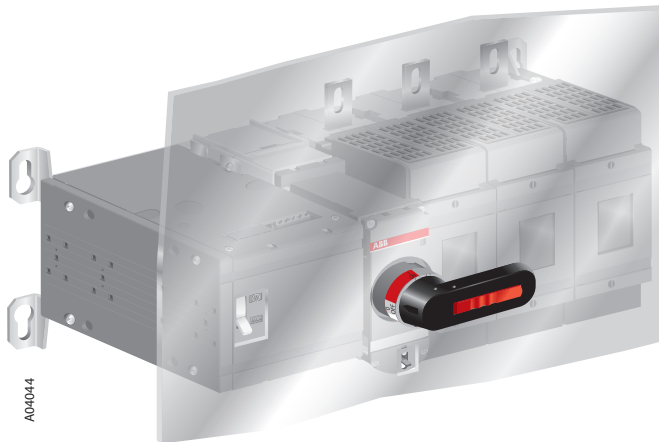
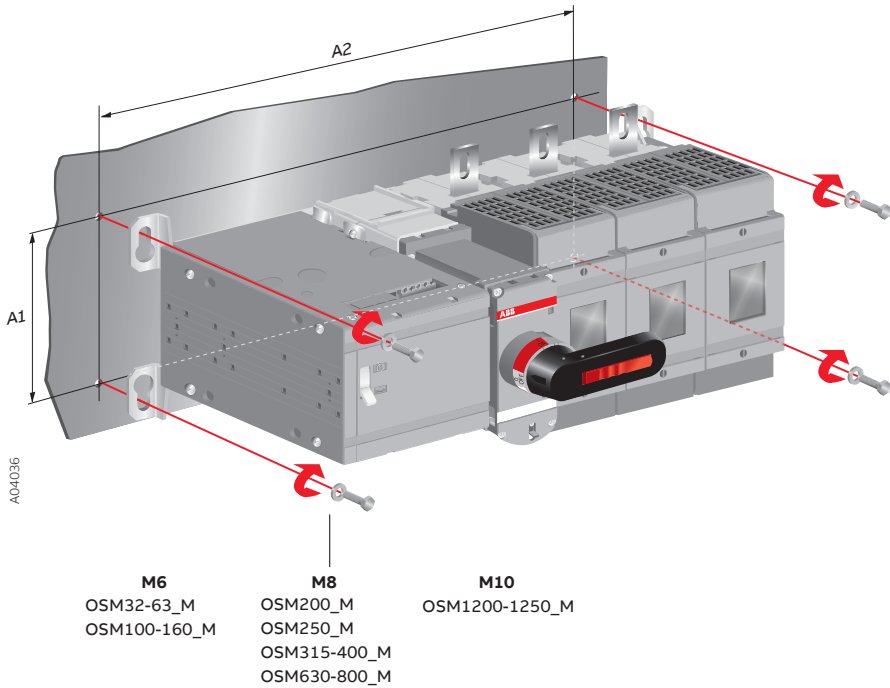

Figure 4.1 An example of using protection against direct contact



OSM32-63_M		
	D3/B3/F3	D4/B4/F4
A1	122	122
A2	187,5	211

OSM100-160_M		
	D3/B3/F3	D4/B4/F4
A1	122	122
A2	272	307

OSM200_M		
	D3/B3	D4/B4
A1	118	118
A2	301,5	345

OSM250_M		
	D3/B3	D4/B4
A1	118	118
A2	332	386

OSM315-400_M		
	D3/B3	D4/B4
A1	136	136
A2	382	446

OSM630-800_M		
	D3/B3	D4/B4
A1	180	180
A2	465,5	553,5

OSM1250_M		
	D3/B3	D4/B4

Figure 4.2 Motorized switch fuses, drilling hole distances / screw-mounting, [mm]

4.2 Dimensional drawings

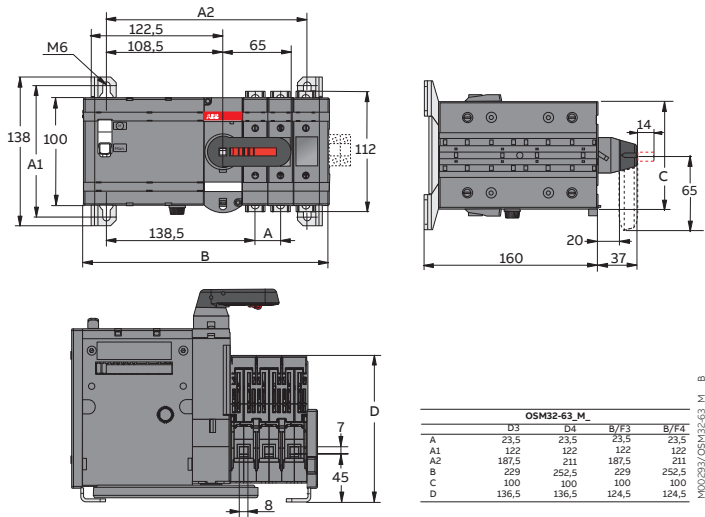

Figure 4.3 OSM32-63_M_

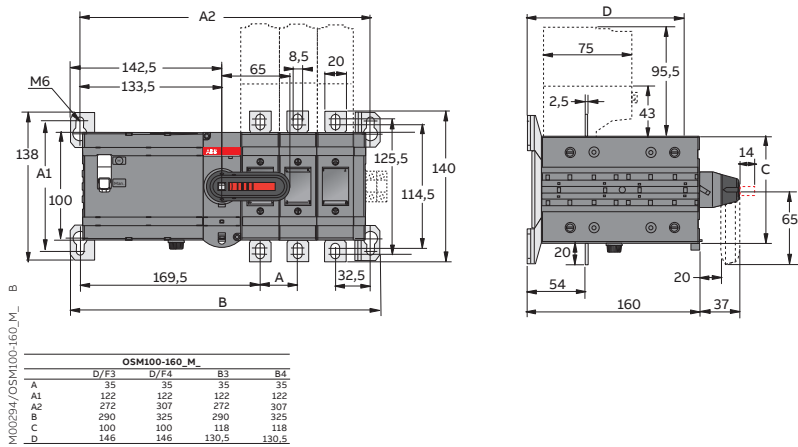

Figure 4.4 OSM100-160_M_

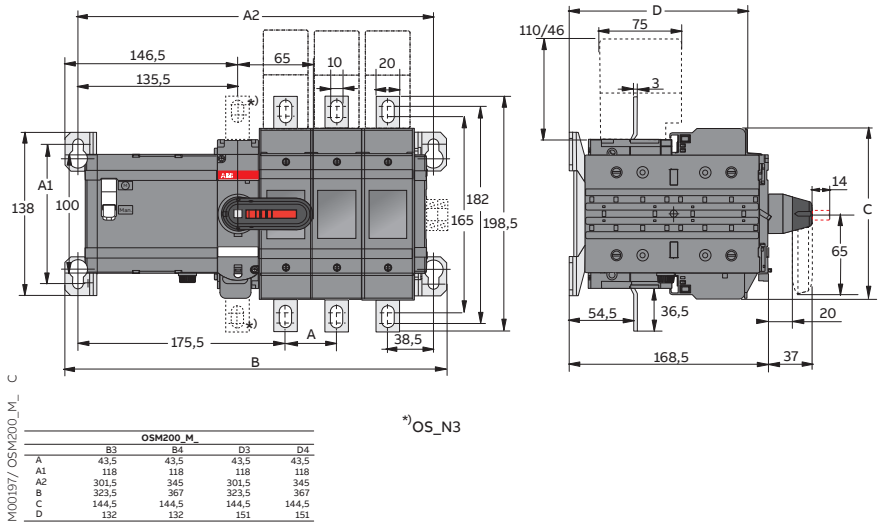

Figure 4.5 OSM200_M_

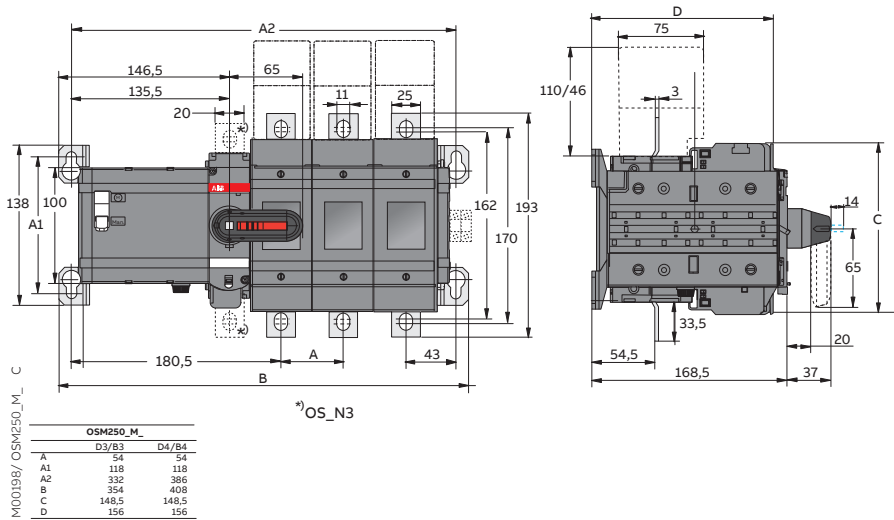

Figure 4.6 OSM250_M_

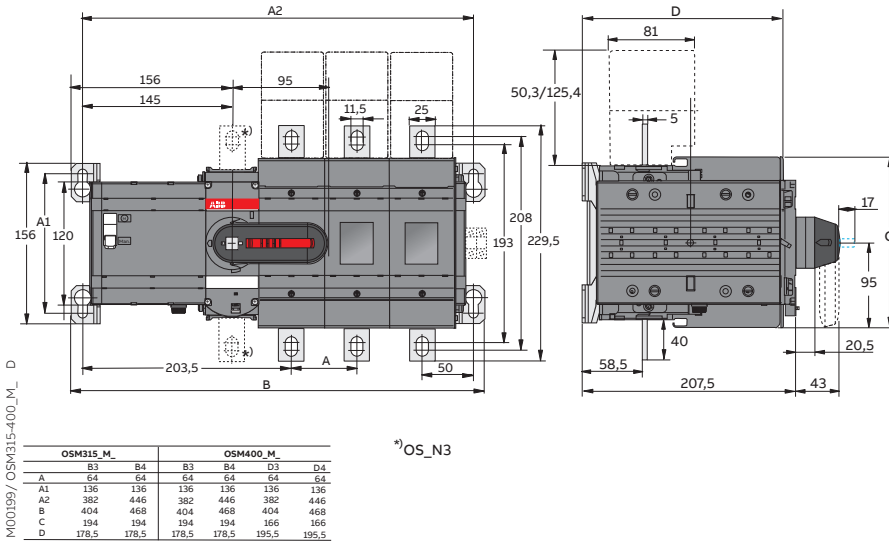

Figure 4.7 OSM315-400_M_

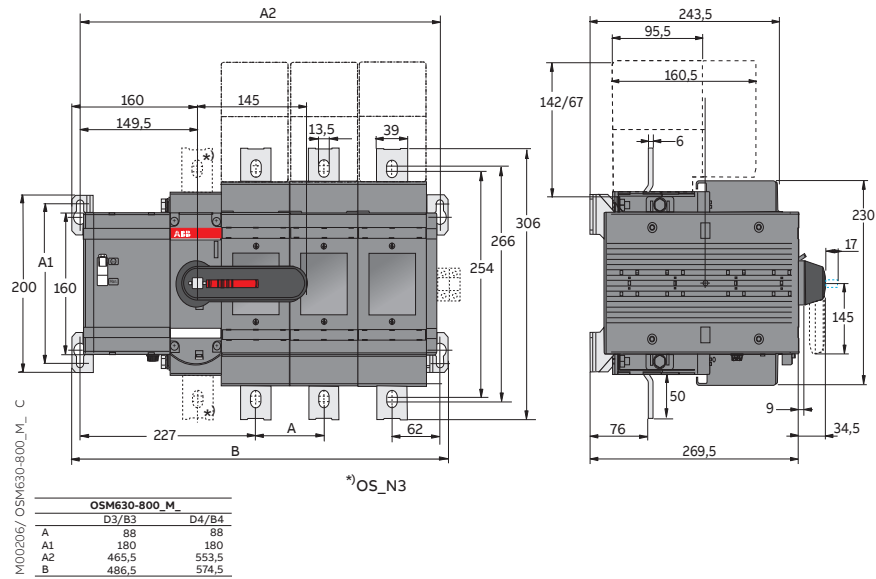

Figure 4.8 OSM630-800_M_

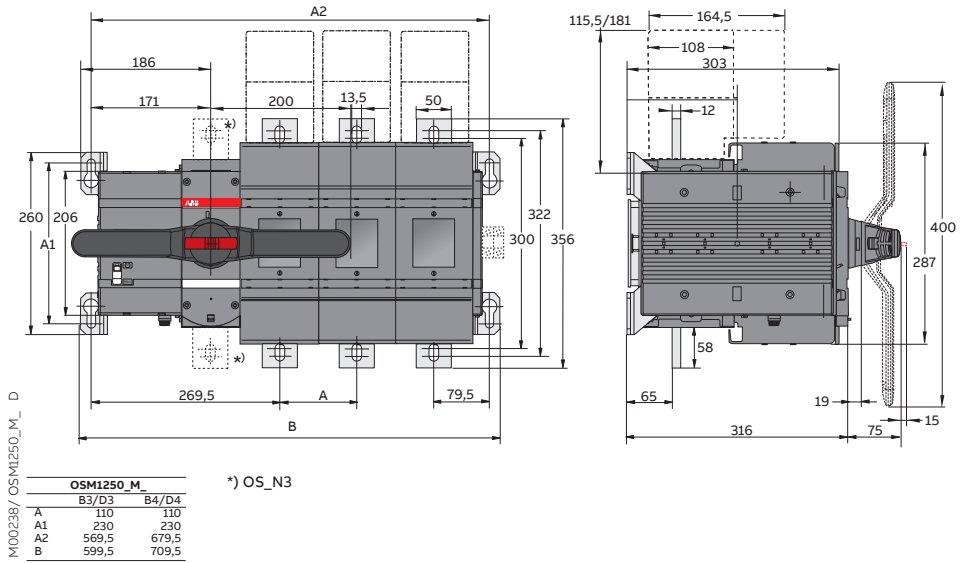

Figure 4.9 OSM1250_M_

4.3 Mounting positions

The recommended mounting positions for motorized switch fuses are horizontal, wall mounted or table mounted.

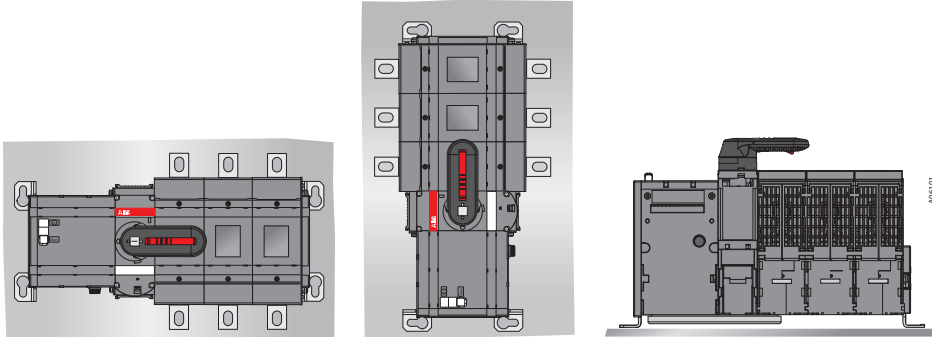

Figure 4.10 Mounting positions



Do not install the motorized switch fuses in any other position than those described above.

4.4 Labelling

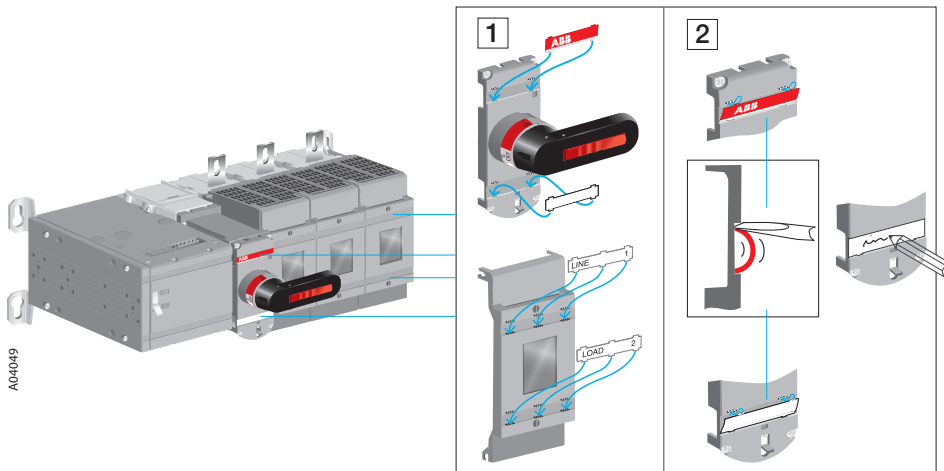

Figure 4.11 Labelling of the motorized switch fuses

5. Connecting



Only an authorised electrician may perform the electrical installation and maintenance of motorized switch fuses. Do not attempt any installation or maintenance actions when a motorized switch fuse is connected to the electrical mains. Before starting work, make sure that the switch fuse is de-energised.

5.1 Control circuit

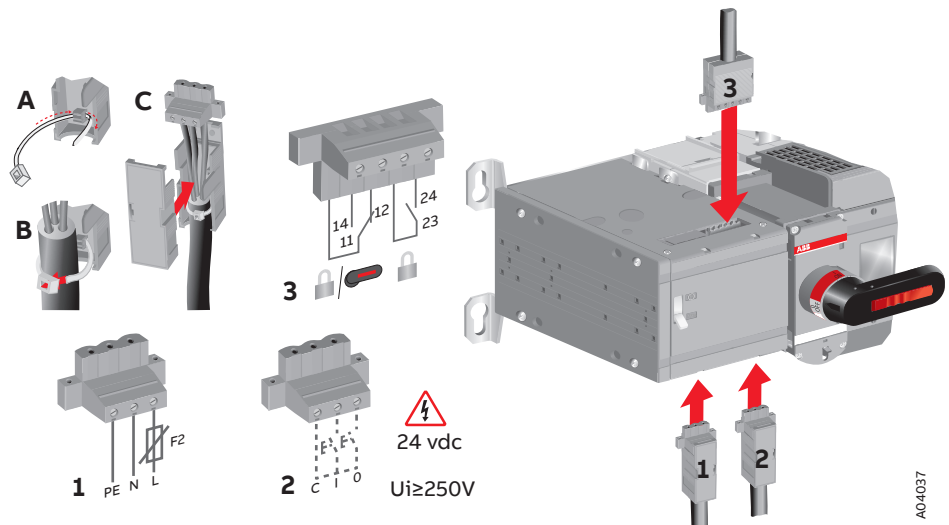

Figure 5.1 Motorized switch fuse terminals

1. Terminal for motor operator voltage supply
2. Control terminal for push buttons or selector switch
3. Terminal for state information of locking



Do not couple power for the control terminal. See the correct terminal for the power supply in Figure 5.1



The control voltage (output C = 24Vdc) on the control terminal is non-isolated, see box 2 in Figure 5.1



When relay outputs are used with inductive loads (such as relays, contactors and motors), they must be protected from voltage spikes using varistors, RC-protectors (AC current) or DC current diodes (DC current).

6. Operating



Never open any covers on the product, if the voltage is connected. There may be still dangerous external control voltages inside the motorized switch fuse even if the voltage is turned off.



Never handle control cables when the voltage of the motorized switch fuse or external control circuits are connected.



Exercise sufficient caution when handling the unit.

6.1 Electrical operation

The motorized switch fuses are available for remote control.

To control the motorized switch fuse electrically:

1. Release the handle from the switch panel by pressing down the locking latch under the switch panel and pulling the handle off, see Figure 6.1.

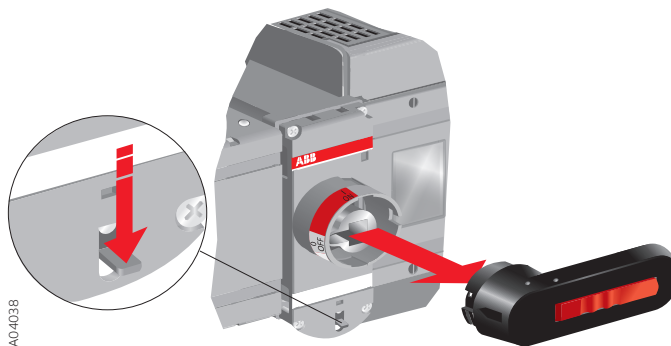

Figure 6.1 Releasing the handle



Electrical operation is disabled if the handle is attached to the switch panel.

- Turn the Motor/Manual selection switch to the Motor (M) position, see Figure 6.2.

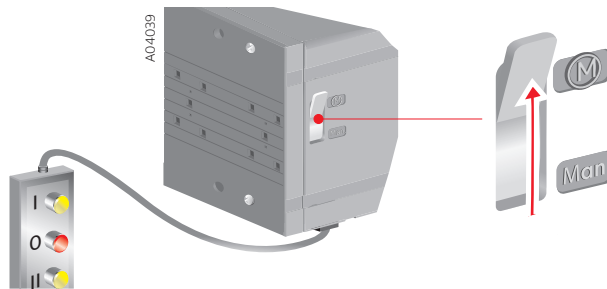

Figure 6.2 Motor/Manual selection switch in the Motor (M) position

- Operate the motorized switch fuse with the push-buttons or selector switch via impulse control or continuous control.



The motor operator is protected from overloading by a fuse (F1) under the motor operator. Only use the same type of fuse that is described on the label close to the fuse.

6.1.1 Impulse control

When using impulse control, the switch fuse is controlled by electric impulses. When you press the control button, the switch fuse is driven to the corresponding position (I or 0). The control impulse must last more than 100 ms to take effect. A new command cannot be given until the switch fuse has reached the position of the previous command. Figure 6.3 shows the operation of the switch fuse with impulse control.



If a new command is given before the switch has reached the position of the previous command, the fuse (F1) may operate.

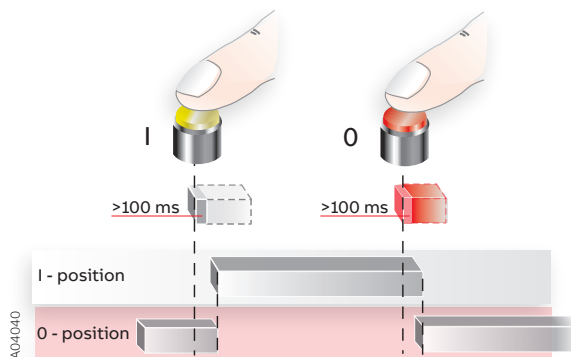

Figure 6.3 Impulse control

6.1.2 Continuous control

When using continuous control, the control command is supplied to the switch continuously. When you press the control button, the switch fuse is driven to the corresponding position (I or 0). The position will change only when the new command is given. Figure 6.4 shows the operation of the switch fuse with continuous control.



The continuous control command can be given with push buttons, cam switches or with relays incorporated in PLC equipment or with other suitable contacts.

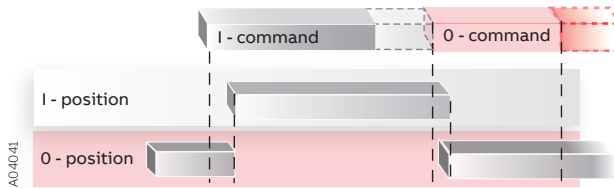

Figure 6.4 Continuous control

6.2 Manual operation using the handle

You can operate the motorized switch fuse manually by using the handle that is included in the delivery.

To control the motorized switch fuse manually:

1. Turn the Motor/Manual selector to the Manual (Man.) position, see Figure 6.5. The motor operator is switched off and electrical operation is prevented.

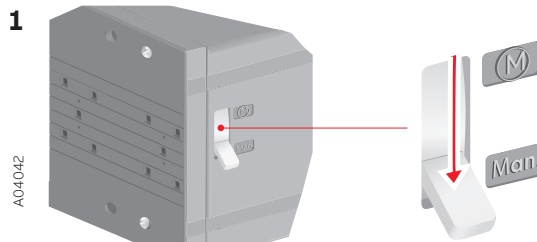

Figure 6.5 Motor/Manual selection in the Man. position

- Attach the handle by pressing it to the switch panel until it clicks into place, see Figure 6.6. You can attach the handle in both positions (I or 0).

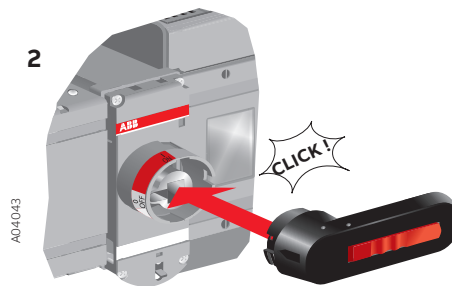

Figure 6.6 Attaching the handle

- Operate the motorized switch fuse by turning the handle to the required position (I or 0).



Electrical operation is prevented when the handle is attached to the switch panel.

6.3 Locking

You can lock the motorized switch fuse to a specific position.

6.3.1 Locking the electrical operation

To disable electrical operation, lock the locking latch with a padlock. After the locking latch has been locked, the switch fuse cannot be operated electrically. You can lock the electrical operation to both positions (I or 0).

To lock electrical operation:

- Pull up the locking latch under the switch panel.
- Place the padlock under the latch, see Figure 6.7.

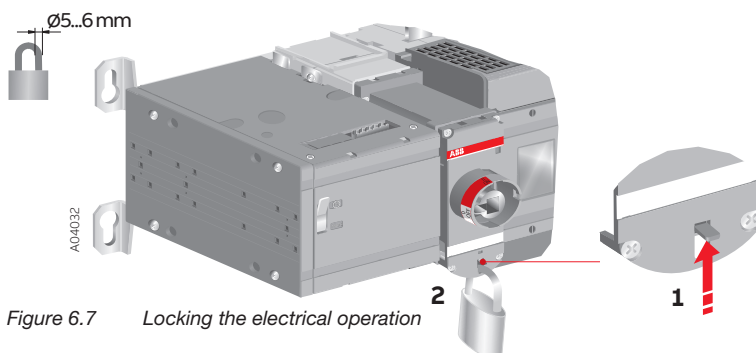

Figure 6.7 Locking the electrical operation



You cannot attach the handle when electrical operation is locked.

6.3.2 Locking the manual operation

By default, manual operation can only be locked to position 0. Locking to position I is optional and possible only with modifications to the switch panel.

To lock manual operation:

1. Turn the handle to the required position.
2. Pull out the clip from the handle and place the padlock on the handle; see Figure 6.8

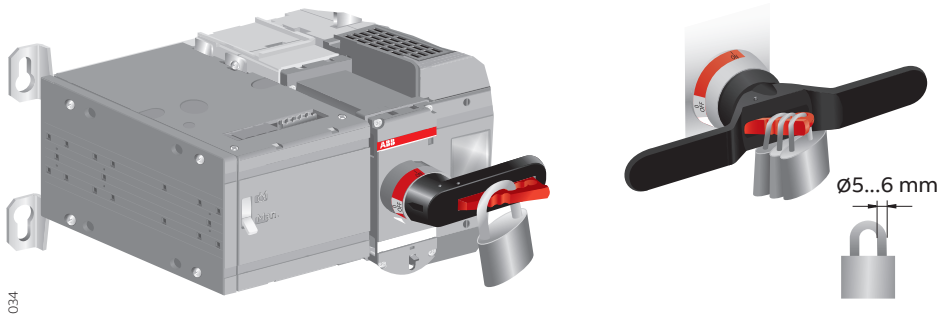

Figure 6.8 Locking the manual operation



The handle cannot be removed when padlocked to position 0.

The following chart shows the locking state information (the voltage on motor operator supply needed)*).

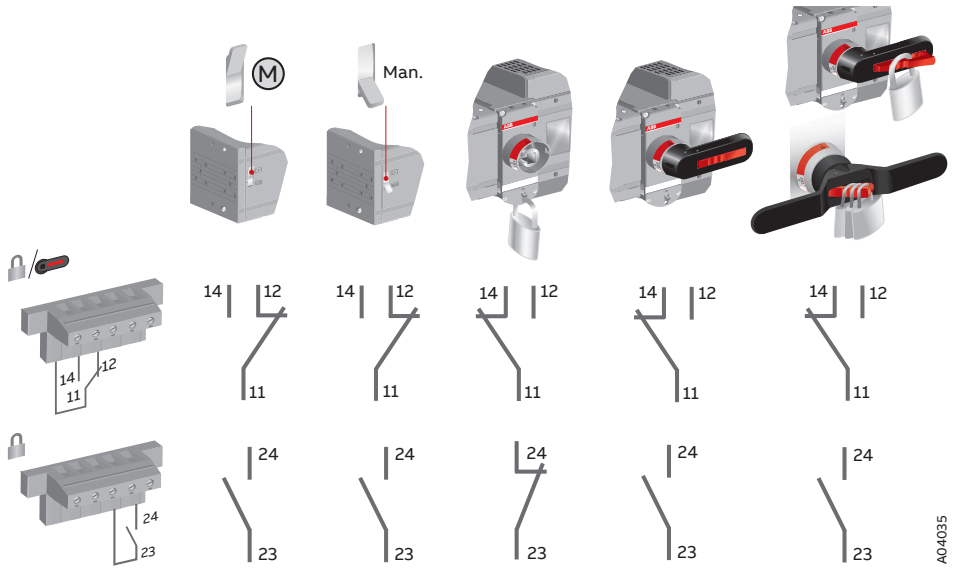

Figure 6.9 Locking state information

7. Technical data

7.1 Motor operator

Motor operator, control circuit	Value	Cabling
Rated operational voltage U [V]	220-240 Vac, 50-60 Hz	
Operating voltage range	0,85... 1,1 x U	
Operating angle	90° 0-I, I-0	
Operating time	See Table 7-2	
Protection degree	IP 20, front panel	
Rated impulse withstand voltage U _{imp}	4 kV	
Voltage supply	PE N L	1,5 -2,5 mm ²
F2		
Cable of the push-buttons (no SELV)	C 1 0	1,5 -2,5 mm ²
Maximum cable length	100 m	
State information of locking (no SELV)		
Handle attached or motor operator locked	11-12-14 (C/O)	1,5 -2,5 mm ²
Locking motor operator	23-24 (NO)	1,5 -2,5 mm ²
Operating temperature	-25... +55 °C	
Transportation and storage temperature	-40... +70 °C	
Altitude	Max. 2000 m	

Table 7.1 General technical data of motor operators

Type	Voltage U _e [V]	Nominal current ^{a)} I _n [A]	Current inrush ^{a)} [A]	Operating time ^{a)} I-0, 0-I, [s]
OSM32-63_	220-240Vac	0,3	1,5	0,5 - 1,0
OSM100-160_	220-240Vac	0,3	1,5	0,5 - 1,0
OSM200-250_	220-240Vac	0,3	1,5	0,5 - 1,0
OSM315-400_	220-240Vac	0,5	2,5	0,5 - 1,2
OSM600-800_	220-240Vac	0,9	4,0	0,5 - 1,5
OSM1200-1250_	220-240Vac	1,4	10,0	0,8 - 2,0

^{a)} Under nominal conditions

Table 7.2 Specified technical data of motor operators

7.2 State information

Measurement	Value
Handle attached or motor operator locked	11-12-14 (C/O): 5A, AC-1 / 250V
Locking motor operator	23-24 (NO): 5A, AC-1 / 250V
SCPD	Max. MCB C2A

Table 7.3 State information

8. Accessories

8.1 Fuse links

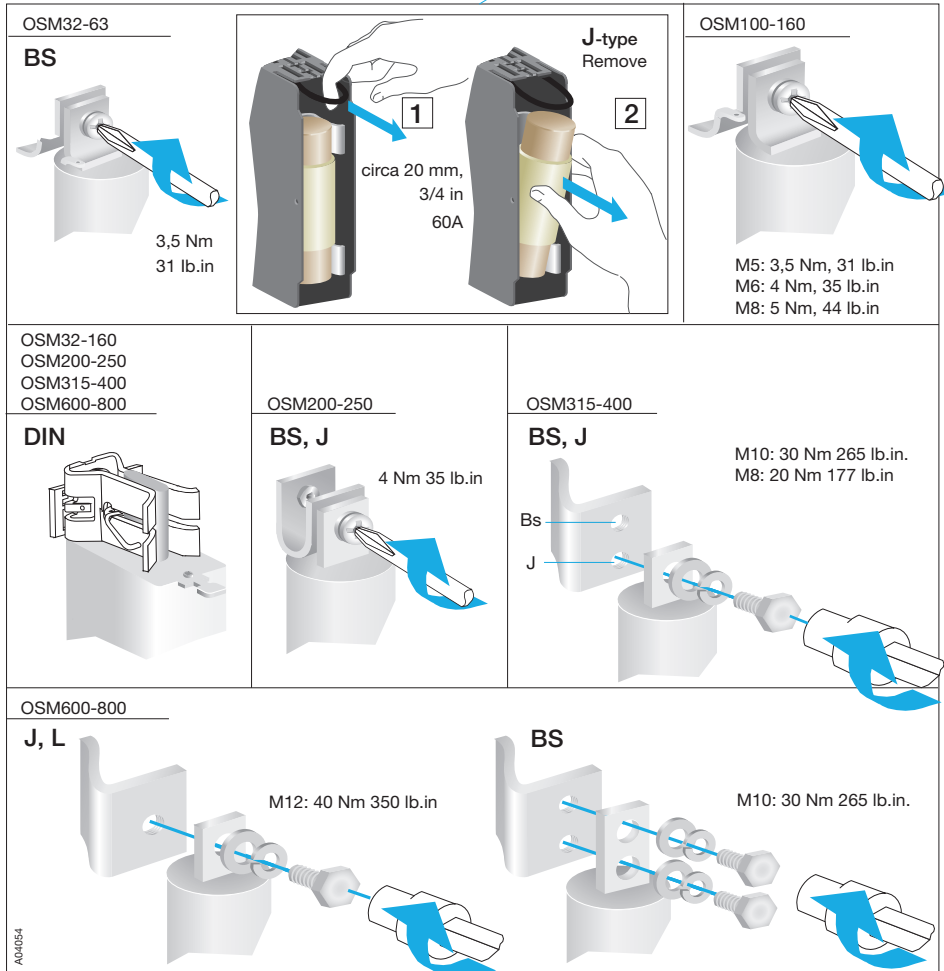
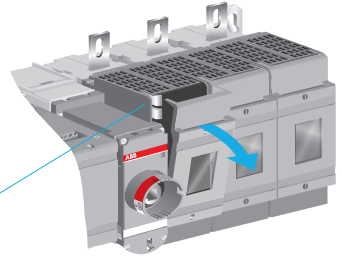

Figure 8.1 Mounting of the different type of fuse links for OSM32-800

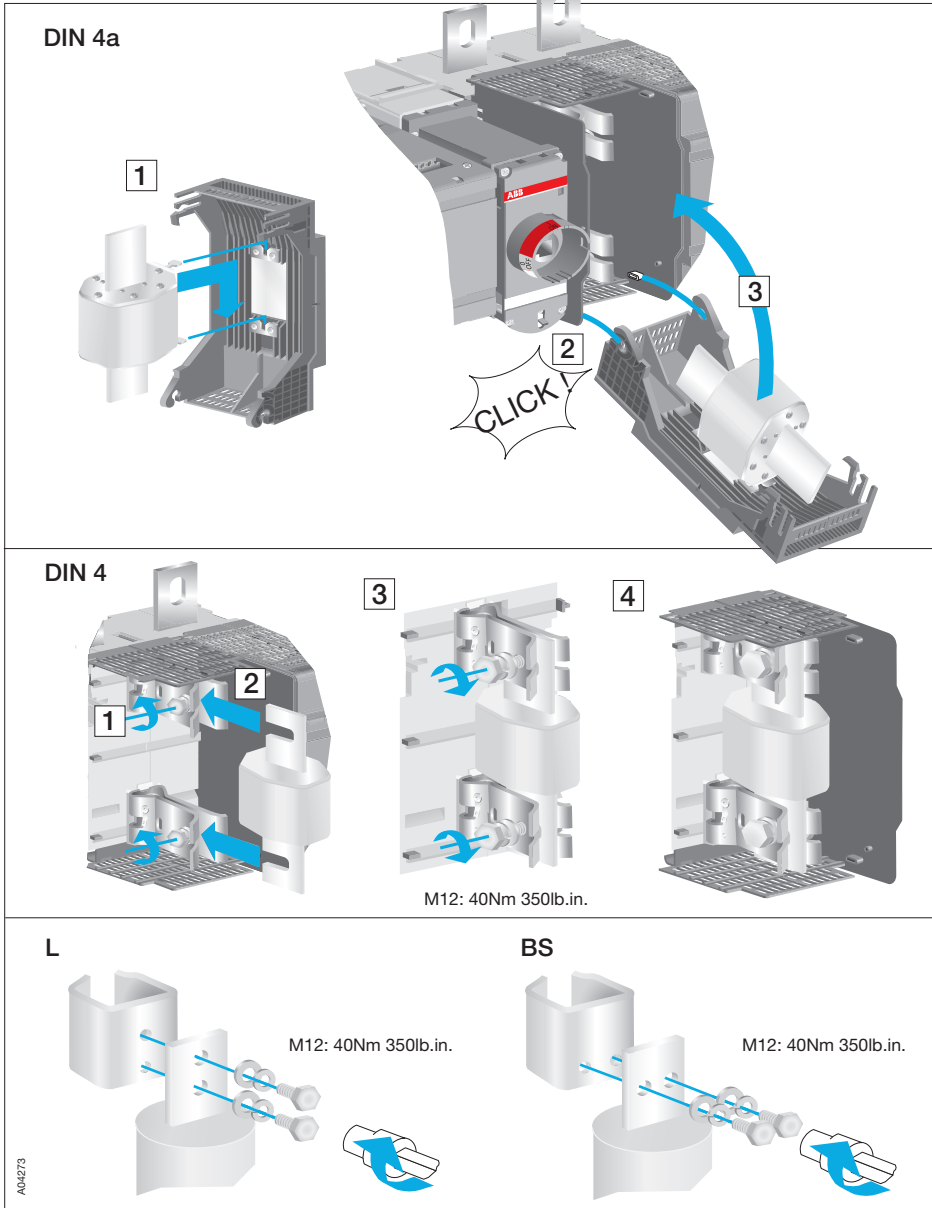

Figure 8.2 Mounting of the different type of fuse links for OSM1250

8.2 Terminal clamp sets

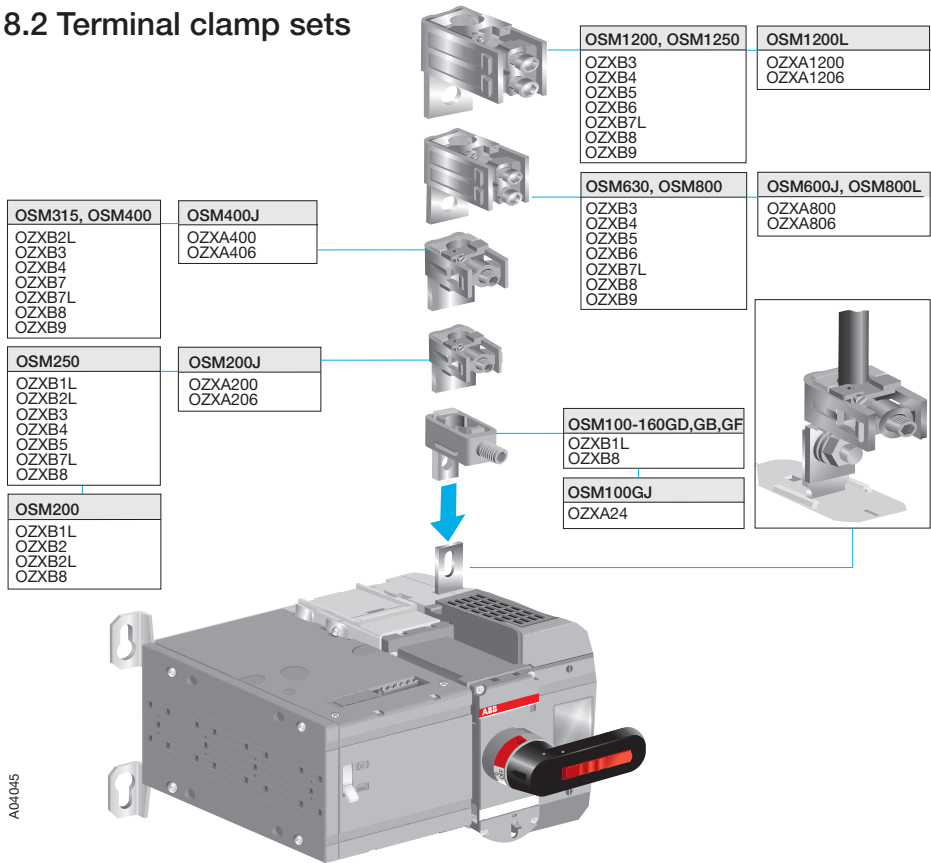

Figure 8.3 Mounting of the terminal clamp sets, types OZXB_ and OZXA_

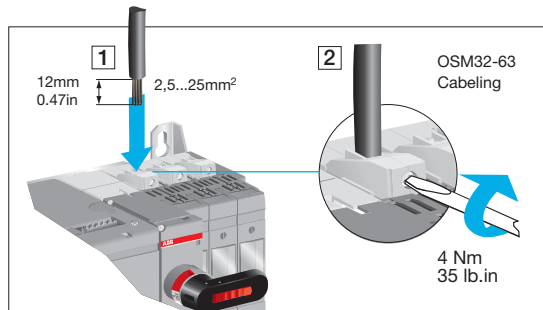

Figure 8.4 Protected tunnel terminals in OSM32-63

8.3 Terminal shrouds

		M	M
OSM100-160_	M8	15...22Nm	133...195 LB.IN
OSM200_	M8	15...22Nm	133...195 LB.IN
OSM250_	M10	30...44Nm	266...390 LB.IN.
OSM315-400_	M10	30...44Nm	266...390 LB.IN.
OSM600-800_	M12	50...75Nm	433...664 LB.IN.
OSM1250_	M12	50...75Nm	443...664 LB.IN.

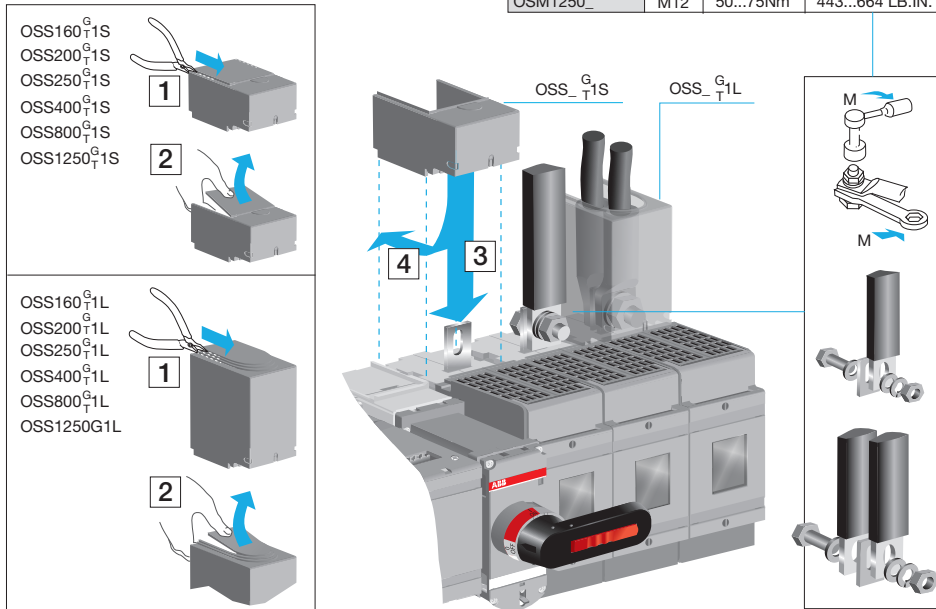

Figure 8.5 Mounting of the terminal shrouds (type OSS_) to the motorized switch fuses

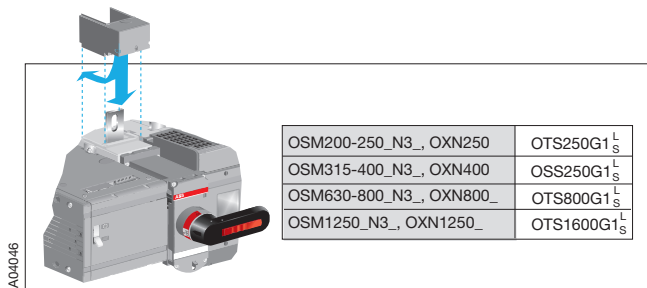
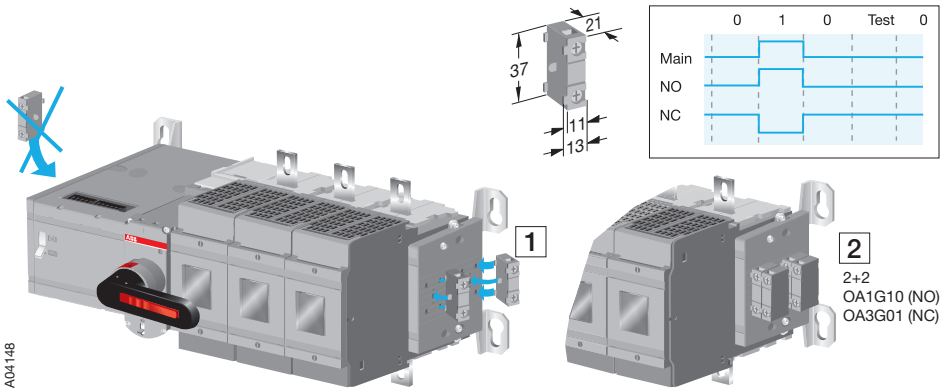

Figure 8.6 Mounting of the terminal shrouds (types OSS_ and OTS_) to the neutral link in the mechanism, when the motorized switch fuse, type OSM_N3 (neutral link integrated into the mechanism) is used or when the neutral link OXN_ (optional) is used

8.4 Auxiliary contacts

8.4.1 Mounting of auxiliary contacts



A04148

Figure 8.7 Mounting of auxiliary contacts, type OA_ on the right side of the switch fuse

8.4.2 Mounting of Test auxiliary contacts

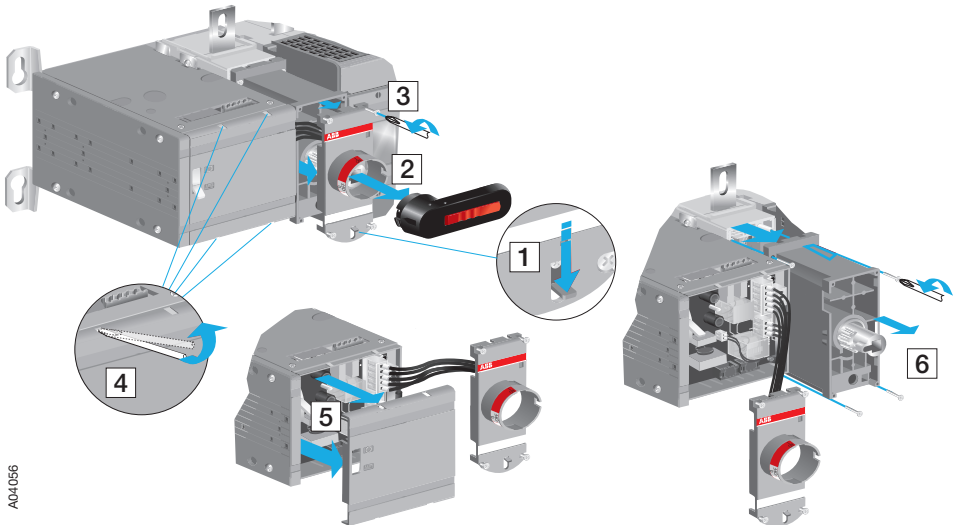

A04056

Figure 8.8 Optional extra; Test auxiliary contacts can be mounted on the switch mechanism, first remove the covers as shown in the figure



Never open any covers on the product, if the voltage is connected. There may be dangerous external control voltages inside the motorized switch fuse even if the voltage is turned off.

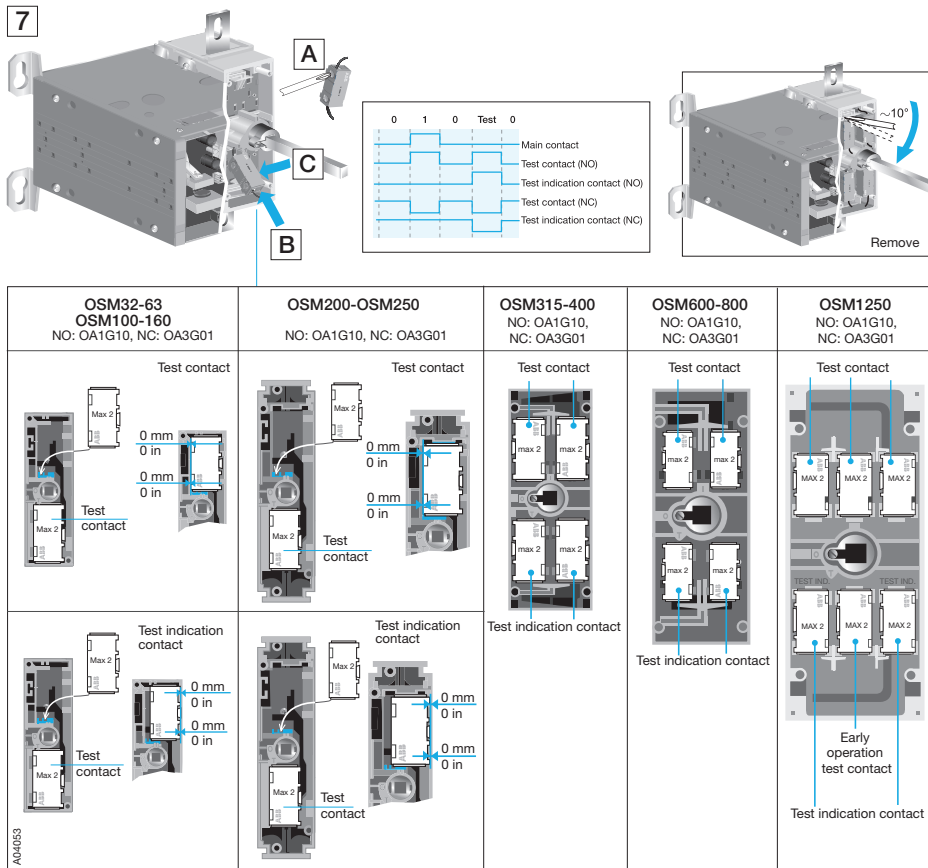

Figure 8.9 Mounting of the Test auxiliary contacts, type OA_ on the switch mechanism

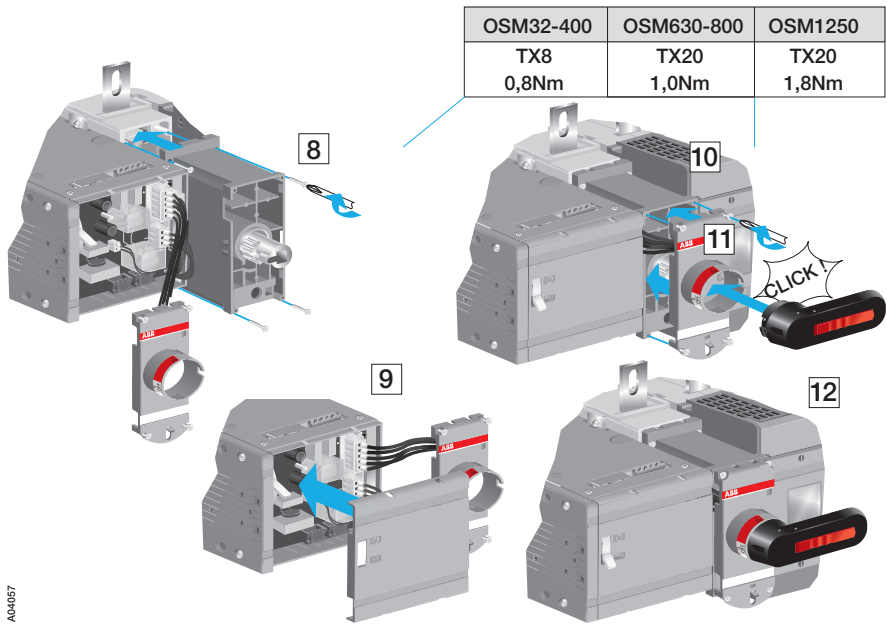
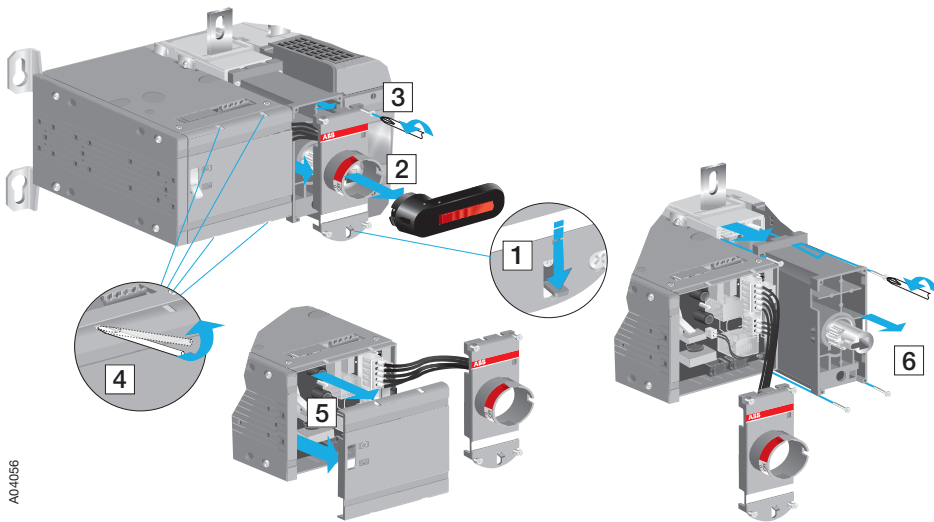

Figure 8.10 Closing the covers after the mounting of the Test auxiliary contacts on the switch mechanism

8.5 Neutral links



AO4056

Figure 8.11 Remove the covers as shown in the figure for the mounting of the neutral links



Never open any covers on the product, if the voltage is connected. There may be dangerous external control voltages inside the motorized switch fuse even if the voltage is turned off.

OSM200-250_N3_

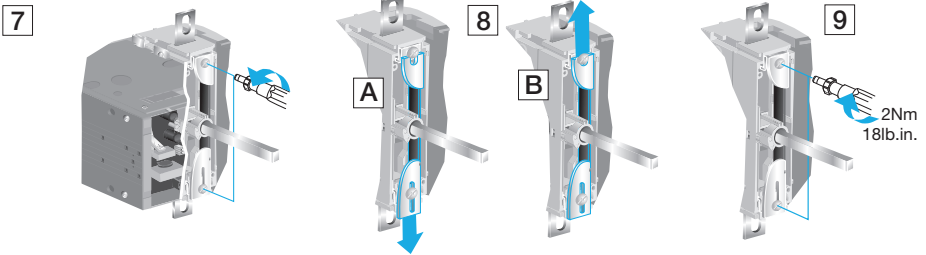

OSM315-1250_N3_

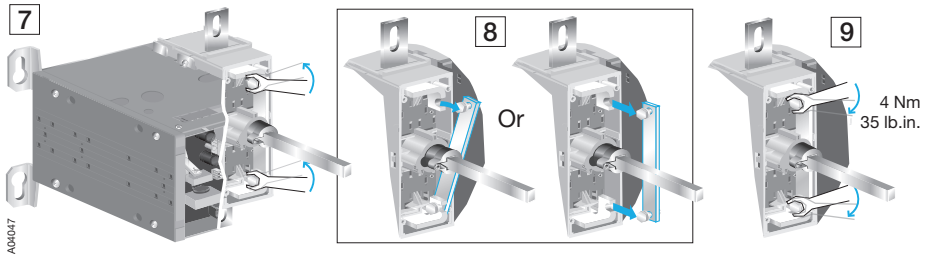

Figure 8.12 Mounting of the detachable neutral links

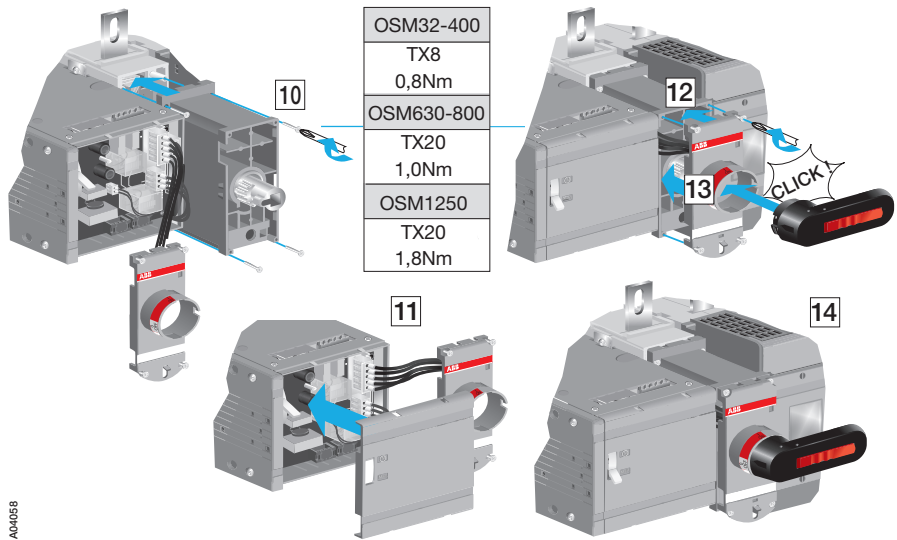

Figure 8.13 Closing the covers after the mounting of the neutral links

8.6 Fuse monitors

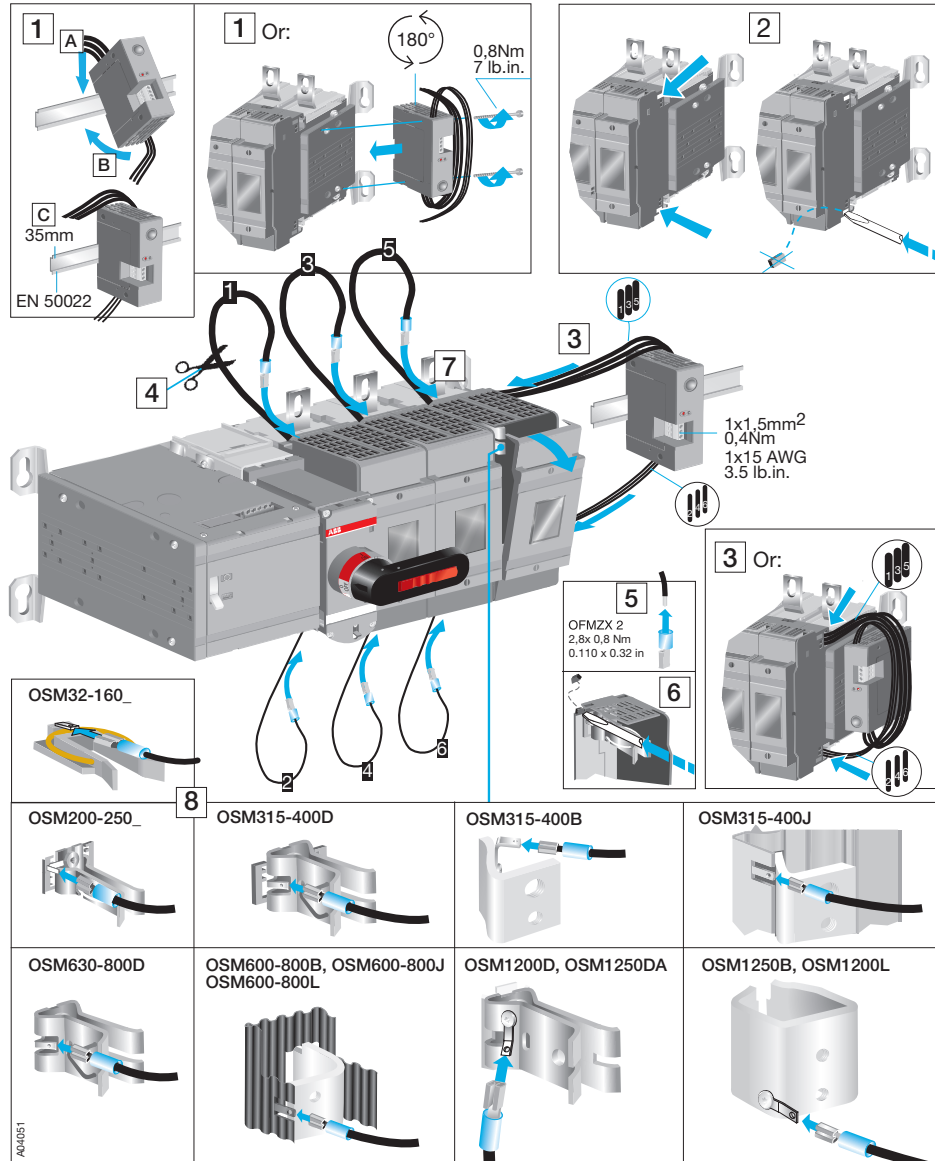

Table 8.14 Mounting of the fuse monitor, type OFS. Mounting options; DIN-rail mounting or mounting on the side switch fuse

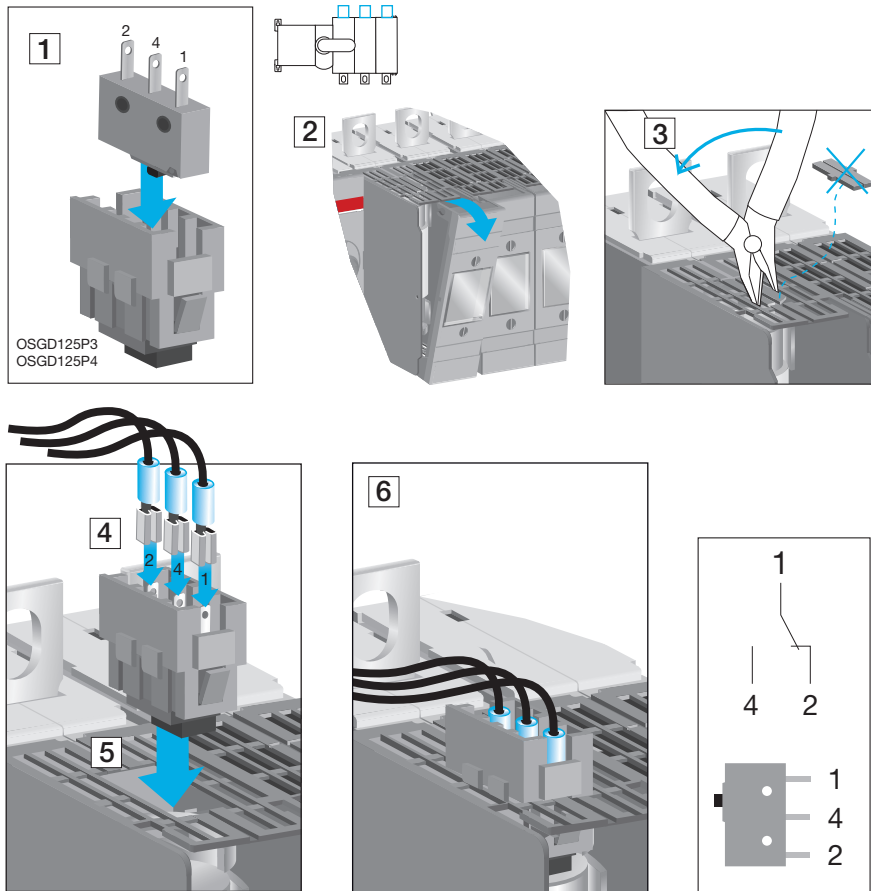

Figure 8.16 Mounting of the blown fuse indicator (DPMM) on OSM125GF_ type OSGD_ , striker type fuse is needed

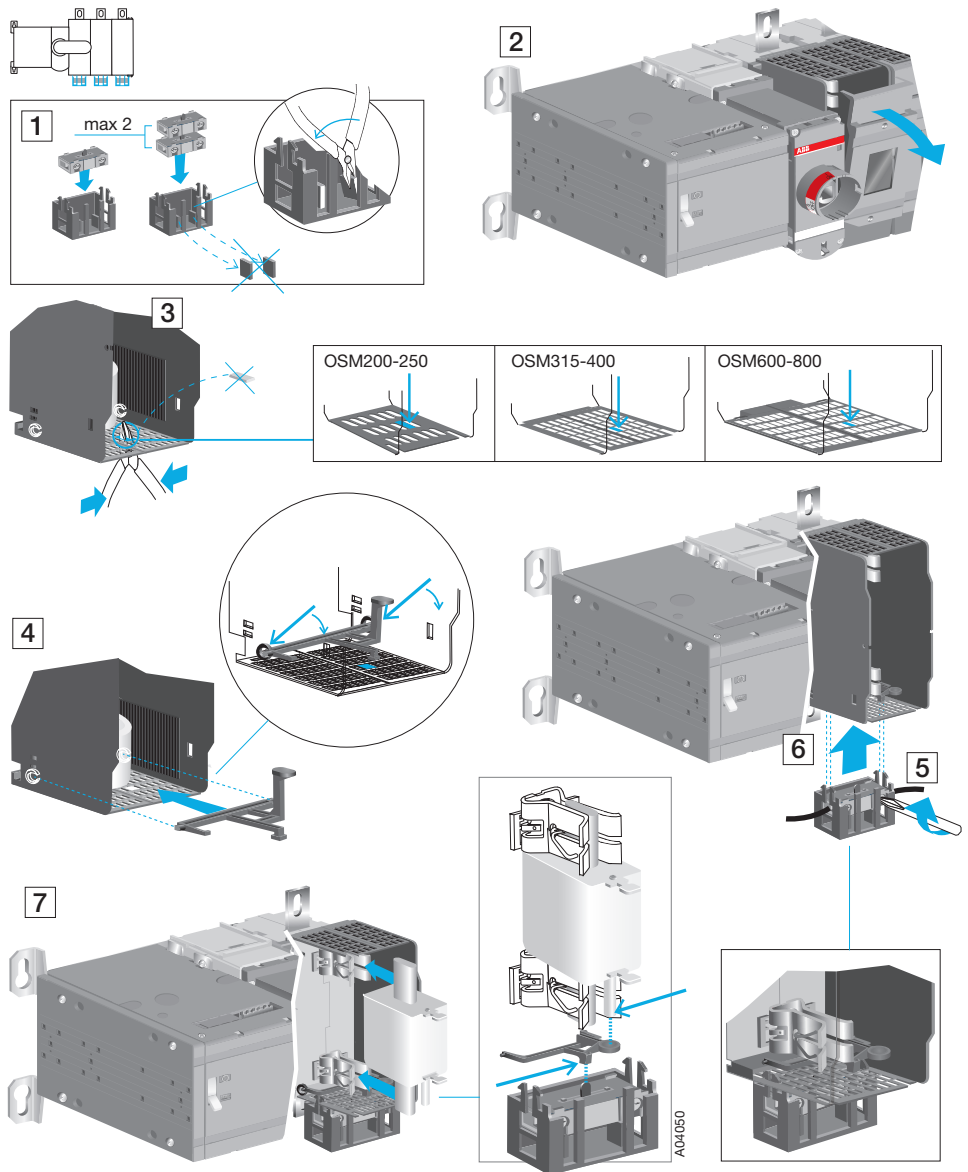
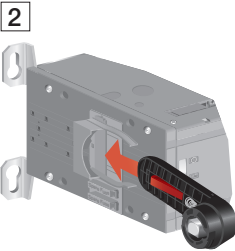
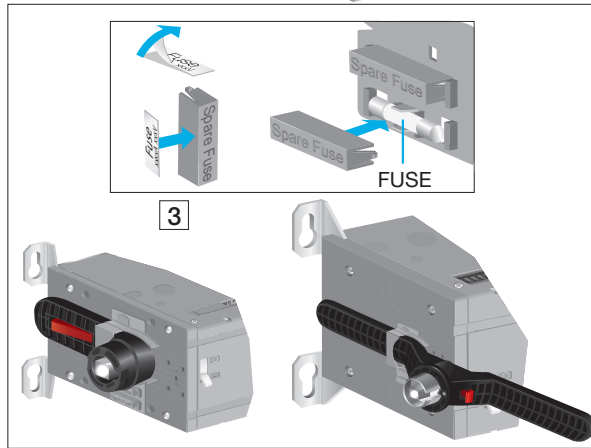
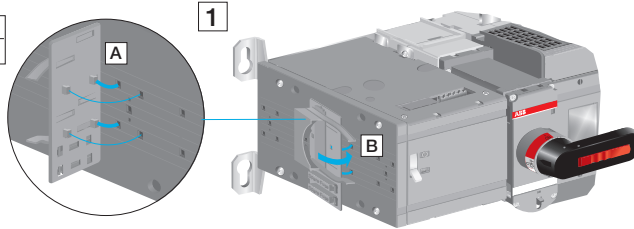
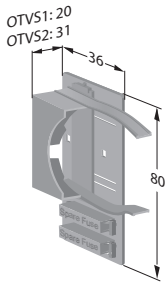

Figure 8.17 Mounting of the blown fuse indicator (DPMM) on OSM250-1250, type OSZX3/4, striker type fuse is needed

8.8 Handle and spare fuse storage

OTVS1	OSM32-250
OTVS2	OSM315-1250



OTVS0	OSM32-250
-------	-----------

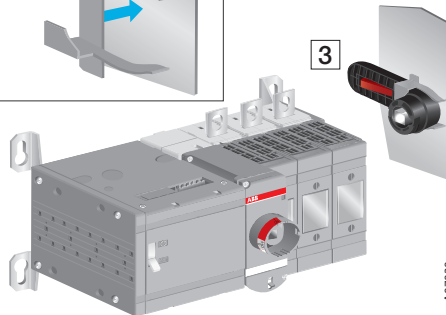
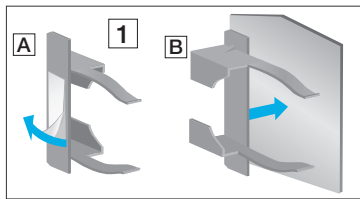
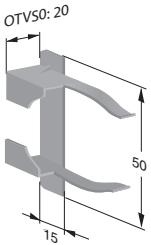

A07030

Figure 8.18 Handle and spare fuses can be stored on the motorized switch-fuse by mounting the accessory OTVS_

9. UL standard switches

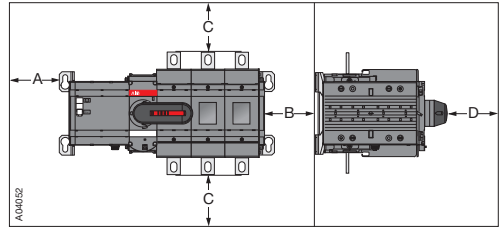

	Current	Height	Width	Depth
OSM60GJ	60 A	250 mm/10 in	250 mm/10 in	250 mm/10 in
OSM100GJ	100 A	300 mm/12 in	350 mm/14 in	250 mm/10 in
OSM200J_	200 A	600 mm/24 in	400 mm/16 in	250 mm/10 in
OSM400J_	400 A	610 mm/24 in	508 mm/20 in	300 mm/12 in
OSM600J_	600 A	914 mm/36 in	610 mm/24 in	350 mm/14 in
OSM800L_	800 A	700 mm/28 in	900 mm/36 in	400 mm/16 in
OSM1200L_	1200 A	1200mm/48 in	750 mm/30 in	508 mm/20 in

OSM60-OSM100GJ, OSM200-OSM600J_ , OSM1200L_		
A	B	D
0	13 mm/0.5 in	13 mm/0.5 in

OSM60GJ	
Cable size	
AWG	C
14-8	38 mm/1.5 in
6	51 mm/2 in
4	100 mm/4 in

OSM100GJ	
Cable size	
AWG	C
14-8	38 mm/1.5 in
6	51 mm/2 in
4-1	100 mm/4 in
1/0	125 mm/5 in
2/0	150 mm/6 in

OSM200J			
Cable size		Cable size	
AWG	C	MCM	C
4-3	100 mm/4 in	250	200 mm/8 in
2	100 mm/4 in	300	250 mm/10 in
1	100 mm/4 in		
1/0	125 mm/5 in		
2/0	150 mm/6 in		
3/0-4/0	175 mm/7 in		

OSM400J_			
Cable size		Cable size	
AWG	C	MCM	C
4-3	100 mm/4 in	250	250 mm/8 in
2	100 mm/4 in	300	250 mm/10 in
1	100 mm/4 in	400	330 mm/13 in
1/0	125 mm/5 in	500	356 mm/14 in
2/0	150 mm/6 in	600	381 mm/15 in
3/0-4/0	175 mm/7 in		

OSM600J_ , OSM800L_			
Cable size		Cable size	
AWG	C	MCM	C
2	100 mm/4 in	250	200 mm/8 in
1	100 mm/4 in	300	250 mm/10 in
1/0	125 mm/5 in	350	300 mm/12 in
2/0	150 mm/6 in	400	330 mm/13 in
3/0-4/0	175 mm/7 in	500	356 mm/14 in
		600	381 mm/15 in

OSM1250L_			
Cable size		Cable size	
AWG	C	MCM	C
2	100 mm/4 in	250	200 mm/8 in
1	100 mm/4 in	300	250 mm/10 in
1/0	125 mm/5 in	350	300 mm/12 in
2/0	150 mm/6 in	400	330 mm/13 in
3/0-4/0	175 mm/7 in	500	356 mm/14 in
		600	381 mm/15 in

Figure 9.1 Clearances per UL 98, minimum enclosure size or equivalent volume



The technical data and dimensions are valid at the time of printing. We reserve the right to subsequent alterations.



BG	Внимание! Опасно напрежение! Да се монтира само от лице с електротехническа квалификация.
CN	警告！电压危险！只能由专业电工进行安装。
CZ	Varování! Nebezpečné napětí! Montáž smí provádět výhradně elektrotechnik!
DA	Advarsel! Farlig elektrisk spænding! Installation må kun foretages af personer med elektroteknisk ekspertise.
DE	Warnung! Gefährliche Spannung! Installation nur durch elektrotechnische Fachkraft.
EL	Προειδοποίηση! Υψηλή τάση! Η εγκατάσταση πρέπει να γίνεται μόνο από εξειδικευμένους ηλεκτροτεχνικούς.
EN	Warning! Hazardous voltage! Installation by person with electrotechnical expertise only.
ES	¡Advertencia! ¡Tensión peligrosa! La instalación deberá ser realizada únicamente por electricistas especializados.
ET	Hoiatus! Ohtlik pinge. Paigaldada võib ainult elektrotehnika-alane ekspert.
FI	Varoitus! Vaarallinen jännite! Asennuksen voi tehdä vain sähköalan ammattihenkilö.
FR	Avertissement! Tension électrique dangereuse! Installation uniquement par des personnes qualifiées en électrotechnique.
HR	Upozorenje! Opasan napon! Postavljati smije samo elektrotehnički stručnjak.
HU	Figyelmeztetés! Vesélyes feszültség! Csak elektrotechnikai tapasztalattal rendelkező szakember helyezheti üzembe.
IE	Rabhadh! Voltas guaiseach! Ba chóir do dhuine ag a bhfuil saineolas leictreicniúil, agus an té sin amháin, é seo a shuiteáil.
IT	Avvertenza! Tensione pericolosa! Fare installare solo da un elettricista qualificato.
LV	Demesio! Pavojinga įtampa! Dirbti leidžiama tik elektrotechniko patirties turintiems asmenims.
LT	Uzmanību! Bīstami - elektrība! Montāžas darbus drīkst veikt tikai personas, kurām ir atbilstošas elektrotehniskās zināšanas.
MT	Twissija! Vultaġġ perikoluż! Għandu jigi installat biss minn persuna b'kompetenza elettroteknika.
NL	Waarschuwing! Gevaarlijke spanning! Mag alleen geïnstalleerd worden door een deskundige elektrotechnicus.
NO	Advarsel! Farlig spenning! Montering skal kun utføres av kvalifiserte personer med elektrokompetanse.
PL	Ostrzeżenie! Niebezpieczne napięcie! Instalacji może dokonać wyłącznie osoba z fachową wiedzą w dziedzinie elektrotechniki.
PT	Aviso! Tensão perigosa! A instalação só deve ser realizada por um electricista especializado.
RO	Avertizare! Tensiune periculoasă! Instalarea trebuie efectuată numai de către o persoană cu experiență în electrotehnică.
RU	Осторожно! Опасное напряжение! Монтаж должен выполняться только специалистом-электриком.
SE	Varning! Farlig spänning! Installation får endast utföras av en elektriker.
SK	Varovanie! Nebezpečné napätie! Montáž môže vykonávať iba skúsený elektrotechnik.

For more information please contact:

ABB Oy
Muottitie 2A 65320 Vaasa, Finland
www.abb.com/lowvoltage

Power and productivity
for a better world™

