

# Data Sheet | Item Number: 232-147/039-000

THT female header; straight; Pin spacing 5 mm; 17-pole; Locking lever; 0.6 x 1.0 mm solder pin; gray

<https://www.wago.com/232-147/039-000>



Color: ■ gray

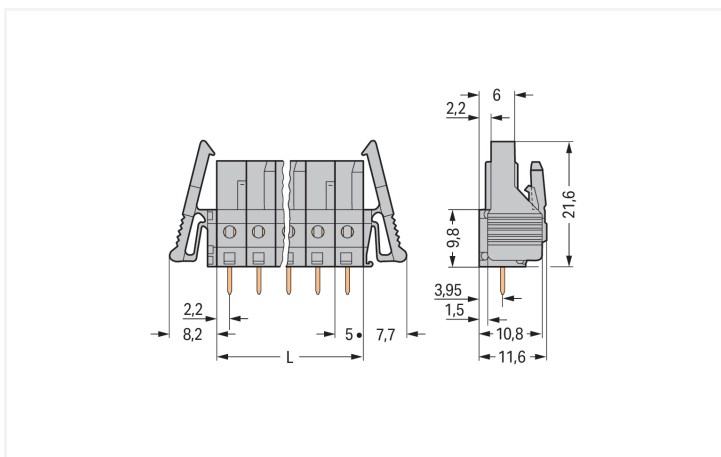

Dimensions in mm

L = pole no. x pin spacing 2- to 3-pole female connectors – one latch only

Female connector, 232 Series, gray

Our female connector (item number 232-147/039-000) is designed for seamless electrical installations. The item's dimensions are (100.9 x 26.6 x 11.6) mm (width x height x depth).

The contact surface is coated with tin. THT is used to solder the pcb connector.

## Notes

## Safety Information

The MCS – MULTI CONNECTION SYSTEM includes connectors without breaking capacity in accordance with DIN EN 61984. When used as intended, these connectors must not be connected/disconnected when live or under load. When used as intended, these connectors must not be connected/disconnected when live or under load. The circuit design should ensure header pins, which can be touched, are not live when unmated.

## Variants:

Other pole numbers  
3.8 mm pin projection for male headers with straight solder pins  
Gold-plated or partially gold-plated contact surfaces  
Other versions (or variants) can be requested from WAGO Sales or configured at <https://configurator.wago.com/>.

## Electrical data

Ratings per	IEC/EN 60664-1		
	III	III	II
Overtoltage category	III	III	II
Pollution degree	3	2	2
Nominal voltage	320 V	320 V	630 V
Rated impulse withstand voltage	4 kV	4 kV	4 kV
Rated current	12 A	12 A	12 A

Approvals per	UL 1059		
	B	C	D
Use group	B	C	D
Rated voltage	300 V	-	300 V
Rated current	16 A	-	10 A

## Ratings

Approvals per	UL 1977		
Rated voltage	600 V		
Rated current	15 A		

## Approvals per

Approvals per	CSA		
	B	C	D
Use group	B	C	D
Rated voltage	300 V	-	300 V
Rated current	15 A	-	10 A

## Connection Data

Clamping units	17
Total number of potentials	17
Number of connection types	1
Number of levels	1

## Connection 1

Pole number	17
-------------	----

## Physical data

Pin spacing	5 mm / 0.197 inches
Width	100.9 mm / 3.972 inches
Height	26.6 mm / 1.047 inches
Height from the surface	21.6 mm / 0.85 inches
Depth	11.6 mm / 0.457 inches
Solder pin length	5 mm
Solder pin dimensions	0.6 x 1 mm
Drilled hole diameter with tolerance	1.3 <sup>(+0.1)</sup> mm

## Mechanical data

Variable coding	Yes
Anti-rotation protection	Yes

### Plug-in connection

Contact type (pluggable connector)	Female connector/socket
Connector (connection type)	for PCB
Mismating protection	No
Mating direction to the PCB	90 °
Locking of plug-in connection	Locking lever

### PCB contact

PCB contact	THT
Solder pin arrangement	over the entire female connector (in-line)
Number of solder pins per potential	1

### Material data

Note (material data)	<a href="#">Information on material specifications can be found here</a>
Color	gray
Material group	I
Insulation material (main housing)	Polyamide (PA66)
Flammability class per UL94	V0
Contact material	Copper alloy
Contact Plating	Tin
Fire load	0.285 MJ
Weight	16.6 g

### Environmental requirements

Limit temperature range	-60 ... +100 °C
Processing temperature	-35 ... +60 °C

### Environmental Testing

Test specification: Railway applications – Rolling stock – Electronic equipment	DIN EN 50155 (VDE 0115-200):2022-06
Test procedure: Railway applications – Rolling stock equipment – Vibration and shock tests	DIN EN 61373 (VDE 0115-0106):2011-04
Spectrum/Mounting location	Service life test, Category 1, Class A/B
Functional test with noise-like oscillations	Test passed according to Section 8 of the standard
Frequency	$f_1 = 5 \text{ Hz}$ to $f_2 = 150 \text{ Hz}$
Acceleration	0.101g (highest test level used for all axes)
Test duration per axis	10 min.
Test directions	X, Y and Z axes
Monitoring of contact faults and interruptions	Passed
Voltage drop measurement before and after each axis	Passed
Simulated service life test through increased levels of noise-like oscillations	Test passed according to Section 9 of the standard
Frequency	$f_1 = 5 \text{ Hz}$ to $f_2 = 150 \text{ Hz}$
Acceleration	0.572g (highest test level used for all axes)
Test duration per axis	5 h
Test directions	X, Y and Z axes
Extended testing: Monitoring of contact faults and interruptions	Passed
Extended testing: Voltage drop measurement before and after each axis	Passed
Shock test	Test passed according to Section 10 of the standard

**Environmental Testing**

Shock pulse form	Half sine
Acceleration	5g (highest test level used for all axes)
Shock duration	30 ms
Number of shocks (per axis)	3 pos. und 3 neg.
Test directions	X, Y and Z axes
Extended testing: Monitoring of contact faults and interruptions	Passed
Extended testing: Voltage drop measurement before and after each axis	Passed
Vibration and shock stress for rolling stock equipment	Passed

**Commercial data**

PU (SPU)	10 pcs
Packaging type	Box
Country of origin	DE
GTIN	4055143678889
Customs tariff number	85366990990

**Product Classification**

UNSPSC	39121409
eCl@ss 10.0	27-44-04-02
eCl@ss 9.0	27-44-04-02
ETIM 9.0	EC002637
ETIM 10.0	EC002637
ECCN	NO US CLASSIFICATION

**Environmental Product Compliance**

RoHS Compliance Status	Compliant, No Exemption
------------------------	-------------------------

**Approvals / Certificates**

**General approvals**



Approval	Standard	Certificate Name
CSA CSA Group	C22.2	1466354

**Declarations of conformity and manufacturer's declarations**



Approval	Standard	Certificate Name
Railway WAGO GmbH & Co. KG	-	Railway Ready

**Approvals for marine applications**



Approval	Standard	Certificate Name
BV Bureau Veritas S.A.	IEC 60998	11915/E0 BV

## Downloads

### Environmental Product Compliance

#### Compliance Search

Environmental Product  
Compliance  
232-147/039-000



## Documentation

#### Additional Information

Technical Section

03.04.2019

pdf

2027.26 KB



## CAD/CAE-Data

#### CAD data

2D/3D Models  
232-147/039-000



#### CAE data

ZUKEN Portal  
232-147/039-000



## PCB Design

Symbol and Footprint  
via SamacSys  
232-147/039-000



Symbol and Footprint  
via Ultra Librarian  
232-147/039-000



## 1 Compatible Products

### 1.1 System counterpart

#### 1.1.1 Male connector/plug



##### Item No.: 231-617

1-conductor male connector; CAGE  
CLAMP®; 2.5 mm<sup>2</sup>; Pin spacing 5 mm; 17-  
pole; gray

### 1.2 Optional Accessories

#### 1.2.1 Test and measurement

##### 1.2.1.1 Testing accessories



##### Item No.: 231-661

Test plugs for female connectors; for 5  
mm and 5.08 mm pin spacing; 2,50 mm<sup>2</sup>;  
light gray

Subject to changes. Please also observe the further product documentation!

Current addresses can be found at: [www.wago.com](http://www.wago.com)