

Features

- Mechanical connector for Otao Linear luminaires to build continuous line, 1pce per pack.

Product Overview

Product name	OTAO LINEAR FAST CONNECTOR
Technology	LED (3 SDCM)
Housing	Steel
Mount	Ceiling recessed mounting, Ceiling surface mounting, Wall surface mounted, Suspended
General application	Office, Education
ETIM Class	EC002557
E-number FI	4170606
Colour Variation Initial (SDCM)	N/A
Photobiological Risk Group	Not applicable
Housing colour	Nickel
Product EAN number	5410288418209
Warranty	5 years

OTAO LINEAR FAST CONNECTOR 0041820

Technical drawings

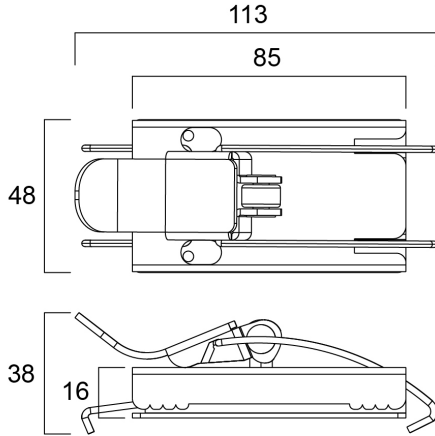

Data table

GENERAL DATA

Product name	OTAO LINEAR FAST CONNECTOR
Technology	LED (3 SDCM)
Type of accessory	Connector
Housing	Steel
Mount	Ceiling recessed mounting, Ceiling surface mounting, Wall surface mounted, Suspended
General application	Office, Education
Operating temperature range (°C)	5°C...+50°C
ETIM Class	EC002557
E-number FI	4170606
Warranty	5 years

OPTICAL DATA

Colour Variation Initial (SDCM)	N/A
Photobiological Risk Group	Not applicable

OTAO LINEAR FAST CONNECTOR 0041820

ELECTRICAL DATA

Control gear required	No
-----------------------	----

PHYSICAL DATA

Housing colour	Nickel
----------------	--------

Weight (kg)	0.2
-------------	-----

PACKAGING

Product EAN number	5410288418209
--------------------	---------------

Packaging single length / height (cm)	13.7
---------------------------------------	------

Packaging single width (cm)	4.8
-----------------------------	-----

Packaging single depth (cm)	3.7
-----------------------------	-----

DUN14 (inner)	15410288418206
---------------	----------------

Units per outer package	50
-------------------------	----

Packaging outer length / height (cm)	29.5
--------------------------------------	------

Packaging outer width (cm)	20.5
----------------------------	------

Packaging outer depth (cm)	26.0
----------------------------	------

SAFETY DATA

Glow Wire Test (°C)	650
---------------------	-----

Optimal operating condition (°C)	5-50
----------------------------------	------

Special purpose lamp	No
----------------------	----

Dry applications use only	No
---------------------------	----

Suitable for household illumination	No
-------------------------------------	----