

Walraven RapidStrut® Rail Connector 90° G2 (BUP1000)

(H2804)

to make Strut rail fabrications

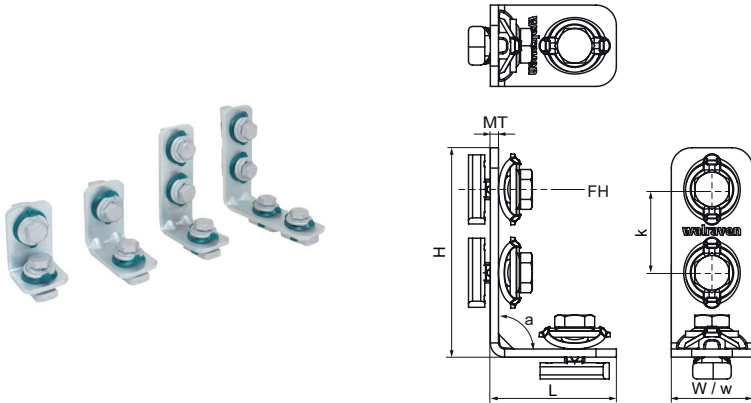

Features & benefits

- connector with pre-assembled Walraven RapidStrut® Slide nut(s)
- to make fabrication with Walraven RapidStrut® Rail
- ready-to-use pre-assembled for a quick fixing, and retains assembly in place before final tightening
- 'Direct Twist' technology for easy and secure installation
- visual guide to check the position of the slide nut
- material: metal parts made of steel 1.0332; spring(s) made of POM (polyoxymethylene), green
- product is part of the Walraven UltraProtect® 1000 system
- suitable for in- and outdoor applications
- stands min. 1,000 hours salt spray test (max. 5% red rust) according to ISO 9227

Product Number	For Rail Type	Angle	Total Height	Total Width	Total Length	Material Thickness	Width	Fixing Hole	Heart To Heart Distance	Torque Moment For Installation	Maximum Allowed Load Faz	Maximum Allowed Load Fax
Reference Letter		a	H	W	L	MT	w	FH	k	T_{inst}	$F_{a,z}$	$F_{a,x}$
Unit description		°	mm	mm	mm	mm	mm	mm	mm	Nm	N	N
665885102	41x21, 41x41, 41x51, 41x62, 41x82	90	72.75	40	52.75	4.00	40	13.8	41	40	4,000	2,270
665885202	41x21, 41x41, 41x51, 41x62, 41x82	90	72.75	40	72.75	4.00	40	13.8	41	40	4,000	2,270
665885203	41x21, 41x41, 41x51, 41x62, 41x82	90	113.75	40	72.75	4.00	40	13.8	41	40	4,000	2,270
665885205	41x21, 41x41, 41x51, 41x62, 41x82	90	113.75	40	113.75	4.00	40	13.8	41	40	4,500	4,700