

GUIDE

CONTACTORS AND OVERLOAD RELAYS



ABB is a pioneering technology leader in electrification products, robotics and motion, and industrial automation, serving customers in utilities, industry, transport and infrastructure globally.

Continuing a history of innovation spanning more than 130 years, ABB today is writing the future of industrial digitalization with two clear value propositions: bringing electricity from any power plant to any plug and automating industries from natural resources to finished products.

GENERAL INDEX

Click on one of the boxes to access the corresponding chapter.

STANDARDS AND APPROVALS

GENERAL PRODUCT OVERVIEW CONTACTORS

LOAD TYPES

SELECTION CRITERIA

INSTALLATION AND DE-INSTALLATION

INSTALLATION AND COMMISSIONING FOR CONTACTORS

GENERAL PRODUCT OVERVIEW OVERLOAD RELAYS

SELECTION CRITERIA

INSTALLATION AND COMMISSIONING FOR OVERLOAD RELAYS

GLOSSARY

FOREWORD

ABB offers a wide range of contactors, and we realize that with all the standards, rules, listings and codes, the what, when, where, why and how of contactors can get complicated. The following information is provided to aid in the proper use of ABB contactors and all their capabilities.

This guide is written as a general guide for people working with contactor applications as well as for those who are simply interested in learning more about the products, standards and applications. All these are relevant for European (based on IEC) and North American applications (UL / CSA).

The guide is neither a complete technical guide nor a manual for all types of ABB's contactor solution. It is a complement to the catalog, data sheets and brochures available for our products and will provide a general overview of what to consider when working with contactors.

More information on contactors as well as other ABB products are available at:

<https://new.abb.com/low-voltage/products/motor-protection>

All the information provided in this guide is only general and each individual application must be handled as a specific case. Be sure to always follow all national and local installation regulations/codes for your specific application.

SAFETY AND WARNINGS

This symbol in conjunction with the signal word "DANGER" indicates an imminent electrical hazard. Failure to observe the related safety note may cause personnel injury or death or equipment damage.



This symbol in conjunction with the signal word "WARNING" indicates a potentially dangerous situation. Failure to observe the related safety note may cause personnel injury or death or equipment damage.



This symbol indicates a safety note: "ATTENTION! Hazardous voltage!"
Installation by a certified service engineer only."



This symbol in conjunction with the signal word "NOTE" indicates operator tips, particularly useful or important information for the use of the product. This symbol and wording do not indicate a dangerous situation.



This symbol indicates a compulsory action: "Reading the instruction manual/booklet before starting work or before operating equipment or machinery."



Recycle.



Do not dispose of this in ordinary trash.

AF CONTACTOR RANGE

The simplest way to get the control and performance of the customers need. ABB's contactor range offers exceptional reliability and performance in a brilliant space-saving design. Use it for motor starting applications up to 750 A 400 V AC-3, or for power switching up to 2850 A 690 V AC-1.



OPTIMIZED LOGISTICS

Cut your costs

With its contactor and motor protection range, ABB has managed to reduce the number of contactor coils to just four. The total number of product variants has been reduced by up to 90%. This simplifies customers' logistics while cutting storage and administration costs.



CONTINUOUS OPERATION

Secure uptime

Prevent stoppages caused by voltage fluctuations. The AF contactor ensures distinct operation in unstable networks and signifies a major advance in motor control and power switching. Voltage sags, dips or surges pose no threat. The AF contactor secures your uptime.



SPEED UP YOUR PROJECTS

Simplify design

Use the same part number in Europe, Asia and North America, as one contactor coil now handles 100 V – 250 V AC / DC, 50 / 60 Hz. By reducing contactor coil energy consumption by up to 80%, panels can be built smaller and transformers more compact.

01



STANDARDS AND APPROVALS

- 1/2 European Directives for contactors**
- 1/2 CE Marking**
- 1/3 Standards in North America**
- 1/3 CCC (China Compulsory Certification)**
- 1/3 Other local approvals based on IEC standards**
- 1/4 Marine approvals**
- 1/4 Potentially explosive atmospheres**
- 1/7 Applied standards**

STANDARDS AND APPROVALS

All ABB low-voltage devices are developed and manufactured according to the rules set out by the International Electrotechnical Commission (IEC). The IEC issues publications that act as a basis for the world market. The applicable standard is the IEC / EN 60947 series for Europe and UL 60947 for North America. All devices are built according to this standard, and in most countries they are not subject to any other tests besides those under the manufacturer's responsibility. In some countries, the law requires additional certification.

European Directives for contactors

The guarantee of free movement of goods within the European Community means that any regulatory differences between member states have been eliminated. The European directives set up common rules that are included in the legislation of each state, and contradictory regulations are abolished.

- Low Voltage Directive 2014/35/EU
Concerns electrical equipment from 50 to 1000 V AC and from 75 to 1500 V DC.
- Machinery Directive 2006/42/EC
Safety specifications of machines and equipment on complete machines
- Electromagnetic Compatibility Directive 2014/30/EC
Applies to all devices able to create electromagnetic disturbance.
- RoHS Directive 2011/65/EU inc. 2015/863/EU
Restriction of the use of Certain Hazardous Substances in Electronic and Electrical Equipment
- WEEE Directive 2012/19/EU
Directive of the European Parliament and of the Council of 4 July 2012 on waste electrical and electronic equipment (Waste Electrical and Electronic Equipment Directive)

CE Marking

When a product is verified according to its applicable EN standard, the product is presumed to fulfill all applicable directives, e.g. the "Low Voltage Directive 2014/35/EU", and it is allowed to apply the CE marking on the product.

For contactors, the CE marking does not cover the "Machinery Directive, Directive 2006/42/EC", which concerns the machine and requires a special verification of the installation. The AF contactor is an electrical device. It is instead covered by the low voltage directive.

The CE marking is not a quality label – it is proof of conformity to the European directives concerning the product. This is a self-declaration from the manufacturer.

Standards in North America

Specifications for US and Canadian markets are quite similar, but differ significantly from IEC standards and European specifications.

- **USA** - UL Underwriters Laboratories Inc.
- **Canada** - CSA Canadian Standards Association

There are different types of UL certification, including UL listed and UL component recognition. The UL Listing means that UL has tested representative samples of the product and determined that it meets UL's requirements. UL's component recognition service, however, only covers the evaluation of components or materials intended for use in a complete product or system.



- **Listed Product**

A product that has been produced under UL's listing and follow-up service program in accordance with the terms of UL's service agreement and that bears the UL listing mark as the manufacturer's declaration that the product complies with UL's requirements.

- **Recognized Component**

A part or subassembly covered under UL's recognition service and intended for factory installation in listed (or other) products. Recognized components are incomplete in certain construction features or restricted in performance capabilities and are not intended for separate installation in the field – they are intended for use as components of incomplete equipment submitted for investigation by UL. Final acceptance of the component in the complete equipment is dependent upon its installation and use in accordance with all applicable use conditions and ratings noted in the component report issued by UL, in the guide information and in the individual client's Recognized Component information page.

The combined UL signs for the USA and Canada are recognized by the authorities of both countries.

ABB contactors with UL certification are UL listed. Most ABB contactors can also be cULus-listed, meaning that they are UL listed to US and Canadian safety standards. All the requirements of both UL and CSA are covered by cULus, so the product is then suitable for use in the US and in Canada.

CCC (China Compulsory Certification)

The China Compulsory Certification (CCC) is a certification system valid in the People's Republic of China, it is mandatory to have the product approved and labelled with a CCC mark to be allowed on the Chinese market.

The CCC applies to both imported and Chinese products. The products requiring certification may only be imported into China, sold in China or used in business activities in China after CCC certification of the product has been applied for and granted. The Chinese GB/T14048.4 standard is based on the IEC-standard IEC 60947-4-1.

Other local approvals based on IEC standards

In addition to IEC and UL standards, many countries have their own local certifications. Some examples of the major ones besides the already mentioned CSA and CCC are listed below:

- **UKCA** – The **UK Conformity Assessment** is the product marking system intended to replace CE marking for the UK market (England, Wales and Scotland)
- **C MIM** – The CMIM MARKING for the safety conformity of industrial products and toys in Morocco
- **EAC** – The **Eurasian Conformity** mark for Russia, Belarus, Armenia, Kazakhstan, Kyrgyzstan, etc. RCM – the Regulatory Compliance Mark for Australia and New Zealand
- **NOM** – The **Norma Oficial Mexicana**
- **KC** – The **Korea Certification** mark

STANDARDS AND APPROVALS

Marine approvals

For contactors used on board ships, maritime insurance companies sometimes require different marine certificates of approval. Some examples include: DNV GL (Det Norske Veritas together with Germanischer Lloyd), BV (Bureau Veritas), LR (Lloyds Register EMEA) which are based on the IEC standard, or ABS (the American Bureau of Shipping) which is based on UL standards or on some other independent certification organization. Typically, marine approvals have special requirements regarding shock, vibrations and humidity.

Potentially explosive atmospheres

Explosive atmospheres occur when flammable gases, mist, vapors or dust are mixed with air. This creates the risk of an explosion. The amount of a substance needed to create an explosive atmosphere depends on the substance in question. The area where this possibility exists is defined as a potentially explosive atmosphere. These atmospheres can be found throughout industries, from chemical, pharmaceutical and food, to power, mining and wood processing. The areas may also be known as "hazardous areas" or "hazardous locations."

International IECEx System

The IECEx System (<http://www.iecex.com/>) from the International Electrotechnical Commission, is a voluntary certification system that verifies compliance with IEC standards related to safety in explosive atmospheres. The IECEx System covers four main areas:

- Certification of service facilities
- IECEx equipment certification
- Ex marking conformity
- Certification of Personnel Competencies

IECEx Conformity Mark System

In order for equipment to receive a conformity "Ex" marking under the IECEx System, it must first receive a certificate of conformity. To obtain a certificate of conformity, there must be:

- An accepted IECEx Quality Assessment Report (QAR)
- An accepted IECEx Test Report for type testing (ExTR)

Products with the IECEx conformity mark have received the IECEx Certificate of Conformity, which confirms the product has the appropriate protection for use in explosive atmospheres and that it has been manufactured under a system subject to ongoing surveillance by certification bodies. The marking also indicates that the product can be supplied to the market without the need for additional testing. The exception is the increased safety (EX e) motor protection type, which must always be tested with the drive it is used with.

European Directives referred to ATEX

Commonly referred to as ATEX (from the French "ATmosphères EXplosibles") this European directive is a combination of two EU directives: The Worker Protection Directive 1999/92/EC and the Product Directive 2014/34/EU. This provides guidelines like the IECEx system with a few exceptions and without the certification of service facilities and certification of personnel competencies. Compliance with the "Essential Health and Safety Requirements" described in the directives is mandatory within the European Union countries. The easiest way to show compliance is to follow harmonized standards.

Potentially explosive atmosphere groups, zones, categories and devices

Within industries, all potentially explosive atmospheres are required to have an area classification referred to as the zone system. The zone system is used all over the world and nowadays also accepted as an alternative system in North America.

The authorities normally determine the area, but it can also be performed by a third party, a notified body or other expert. It is the owner's responsibility to ensure that the classification of their site is performed before suitable products can be selected and installed at the location.

Globally, a zone system is used to classify potentially explosive areas. The Worker Protection Directive 1999/EC and the international standards IEC / EN 60079-10-x define these zones. In all cases, zone classification for potentially explosive atmospheres, zones, categories and devices are the responsibility of the owner of the site where the potentially explosive atmosphere exists.

There are 6 zones:

- **Zone 0 (for gas) and 20 (for dust)**, where there is a continuous presence of an explosive atmosphere.
- **Zone 1 (for gas) and 21 (for dust)**, where there is an occasional occurrence of a potentially explosive atmosphere.
- **Zone 2 (for gas) and 22 (for dust)**, where potentially explosive atmospheres can occur by accident, not during normal operation.

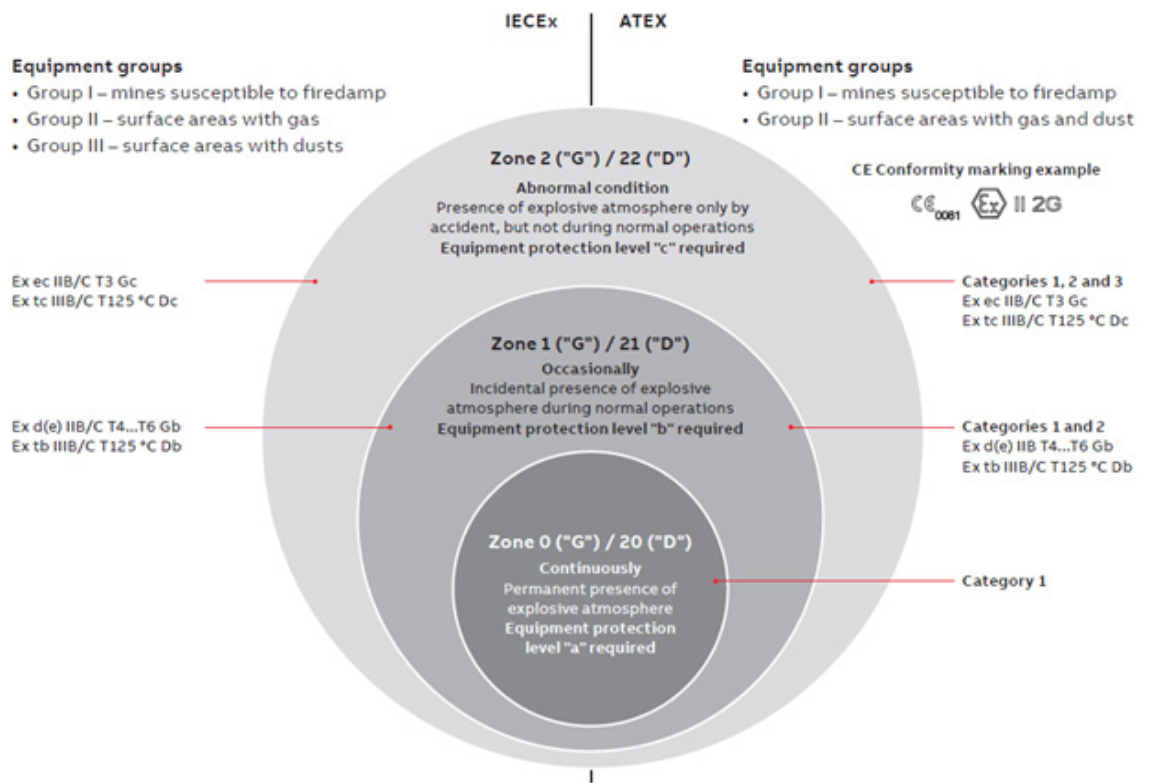

Potentially explosive atmosphere groups, zones, categories and devices. "G" = Gas; "D" = Dust

Equipment categories

Equipment categories are used in the ATEX directive. The category indicates which safety level must be used in each zone. In zone 0/20, category 1 devices must be used; in zone 1/21, category 2 devices; and in zone 2/22, category 3 devices. Classification into categories is particularly important, because all the inspection, maintenance and repair duties of the end user will depend on the category of the product/equipment, not on the zone where it is installed.

Equipment protection levels (EPL)

The latest revisions to the IEC and EN standards include the concept of "equipment protection levels" (EPLs), which identify products according to the ignition risk they might cause. The EPL also considers the potential consequences of an explosion. For zone 0/20, the equipment protection level required would be "a"; for zone 1/21, it would be "b"; and for zone 2/22, the level would be "c".

STANDARDS AND APPROVALS

SELECT THE DEVICE TYPE ACCORDING TO THE ZONE AND CATEGORY/EPL

Standard IEC 60079-0 EN 60079-0		Zone according to IEC 60079-10-x EN 60079-10-x		ATEX Directive 2014/34/EU (previously 94/9/EC)	
Group	EPL	Protection level	Zones	Equipment group	Equipment category
I (Mines)	Ma	Very high	The zone classification is not used in mines	I (Mines)	M1
	Mb	High			M2
II (Gas)	Ga	Very high	0		1G
	Gb	High	1		2G
	Gc	Enhanced	2		3G
III (Dust)	Da	Very high	20	II (Surface)	1D
	Db	High	21		2D
	Dc	Enhanced	22		3D

Overload relays in potentially explosive atmospheres

Overload relays are authorized under device group II, category (2) in the "G" area (areas with potentially explosive gas, steam, smoke or air mixtures) and additionally for the "D" area (areas with combustible dust).
BVS 15 ATEX F 004



II (2) G IECEx BVS 17.0070
II (2) D [Ex]

Overload relays are not suitable for installation and/or operation in potentially explosive areas. It is intended to protect a motor which is installed in the potentially explosive atmosphere. When using the devices in potentially explosive areas, preventive measures must be taken, e. g. operation within a suitable enclosure.

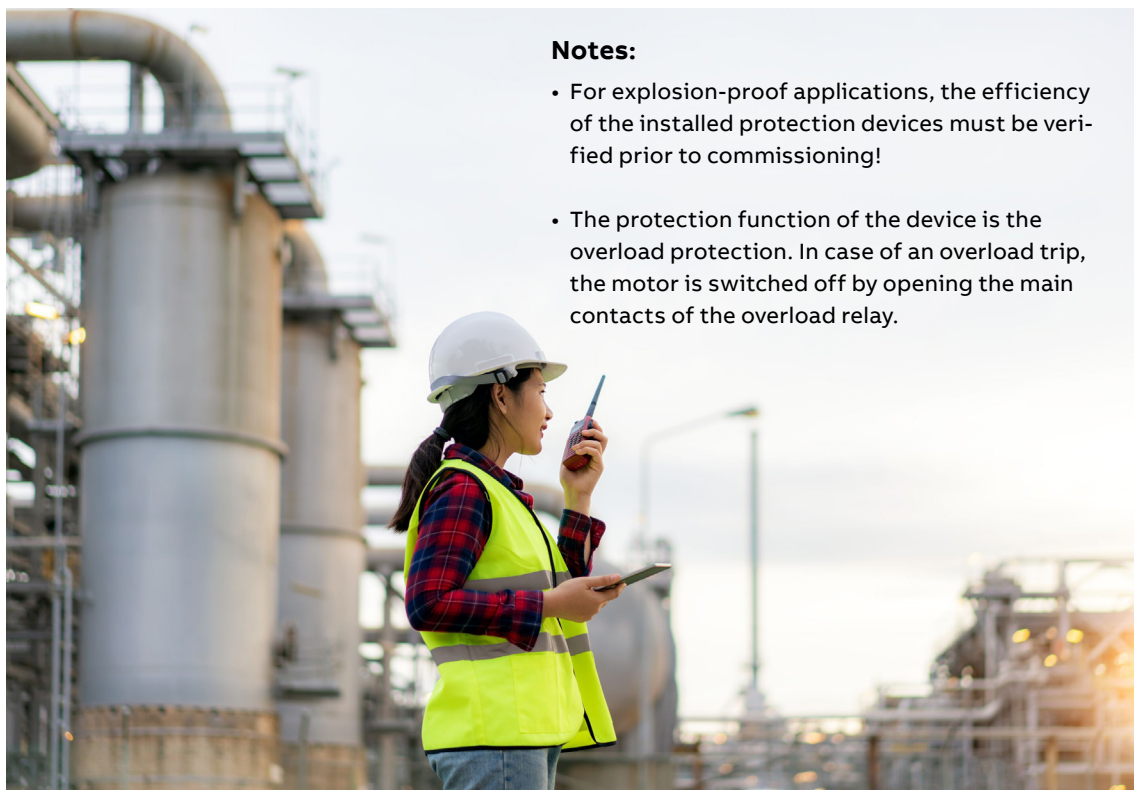

Notes:

- For explosion-proof applications, the efficiency of the installed protection devices must be verified prior to commissioning!
- The protection function of the device is the overload protection. In case of an overload trip, the motor is switched off by opening the main contacts of the overload relay.

Applied standards

The following standards are used or partly used for ABB's contactors.

		Title
International	IEC 60947-1	Low-voltage switchgear and controlgear – Part 1: General rules
	IEC 60947-4-1	Low-voltage switchgear and controlgear – Part 4-1: Contactors and motor starters – Electromechanical contactors and motor starters
	IEC 60947-5-1	Low-voltage switchgear and controlgear – Part 5-1: Control circuit devices and switching elements – Electromechanical control circuit devices
	IEC 60947-5-4	Low-voltage switchgear and controlgear – Part 5-4: Control circuit devices and switching elements. Method of assessing the performance of low-energy contacts. Special tests
	IEC 60947-6-1	Low-voltage switchgear and controlgear – Part 6: Multiple function equipment – Section 1: Automatic transfer switching equipment
	IEC 60204-1	Electrical equipment of industrial machines – Part 1: General requirements
	IEC 60715	Dimensions of low-voltage switchgear and controlgear. Standardized mounting on rails for mechanical support of electrical devices in switchgear and controlgear installations
European standards	EN 50 005	Low-voltage switchgear and controlgear for industrial use – Terminal marking and distinctive number: General rules (Annex L of IEC 60947-1)
	EN 50 011	Low-voltage switchgear and controlgear for industrial use – Terminal marking, distinctive number and distinctive letter for particular contactor relays (Annex M of IEC 60947-5-1)
	EN 60947-1	Low-voltage switchgear and controlgear – Part 1: General rules
	EN 60947-4-1	Low-voltage switchgear and controlgear – Part 4-1: Contactors and motor starters – Electromechanical contactors and motor starters
	EN 60947-5-1	Low-voltage switchgear and controlgear – Part 5-1: Control circuit devices and switching elements – Electromechanical control circuit devices
	EN 60947-5-4	Control circuit devices and switching elements. Method of assessing the performance of low-energy contacts. Special tests
	EN 60947-6-1	Low-voltage switchgear and controlgear – Part 6: Multiple function equipment – Section 1: Automatic transfer switching equipment
	EN 60204-1	Electrical equipment of industrial machines – Part 1: General requirements
	EN 60 715	Dimensions of low-voltage switchgear and controlgear. Standardized mounting on rails for mechanical support of electrical devices in switchgear and controlgear installations
Standards for North America	UL 60947-4-1 (formerly UL 508)	Low-voltage switchgear and controlgear – Part 4-1: Contactors and motor starters – Electromechanical contactors and motor starters
	UL 60947-4-1A	2nd Ed. – Low-voltage switchgear and controlgear – Part 4-1: Contactors and motor starters – Electromechanical contactors and motor starters
	UL 60947-5-1	Low-voltage switchgear and controlgear – Part 5-1: Control circuit devices and switching elements – Electromechanical control circuit devices
Standards for Canada	CSA C22.2 No.60947-1 (formerly CSA C22.2 No.14)	Low-voltage switchgear and controlgear – Part 1: General rules
	CSA C22.2 No.60947-4-1 (formerly CSA C22.2 No.14)	Low-voltage switchgear and controlgear – Part 4-1: Contactors and motor starters – Electromechanical contactors and motor starters
Standards for China	GB/T14048.1	Low-voltage switchgear and controlgear – Part 1: General rules
	GB/T14048.4	Low-voltage switchgear and controlgear – Part 4-1: Contactors and motor starters – Electromechanical contactors and motor starters
	GB/T14048.5	Low-voltage switchgear and controlgear – Part 5-1: Control circuit devices and switching element – Electromechanical control circuit devices

STANDARDS AND APPROVALS

National Standards

European countries' national standards reproduce the corresponding EN... standards. Codification is created by the addition of a prefix to EN numbering. For instance:

- France NF EN...
- Germany DIN EN...
- Great Britain BS EN...
- Italy CEI EN...
- Sweden SS EN...

The following standards are used or partly used for ABB's overload relays.

		Title
International and European standards	IEC / EN 60947-1	Low-voltage switchgear and controlgear – Part 1: General rules
	IEC / EN 60947-4-1	Low-voltage switchgear and controlgear – Part 4-1: Contactors and motor starters – Electromechanical contactors and motor starters
	IEC / EN 60947-5-1	Low-voltage switchgear and controlgear – Part 5-1: Control circuit devices and switching elements – Electromechanical control circuit devices
Standards for North America	UL 60947-4-1 (formerly UL 508)	Low-voltage switchgear and controlgear – Part 4-1: Contactors and motor starters – Electromechanical contactors and motor starters
	UL 60947-4-1A	2nd Ed. - Low-Voltage Switchgear and Controlgear – Part 4-1: Contactors and motor starters – Electromechanical contactors and motor starters
	UL 60947-5-1	Low-voltage switchgear and controlgear – Part 5-1: Control circuit devices and switching elements – Electromechanical control circuit devices
Standards for Canada	CSA C22.2 No.60947-1 (formerly CSA C22.2 No.14)	Low-voltage switchgear and controlgear – Part 1: General rules
	CSA C22.2 No.60947-4-1 (formerly CSA C22.2 No.14)	Low-voltage switchgear and controlgear – Part 4-1: Contactors and motor starters – Electromechanical contactors and motor starters
Standards for China	GB/T14048.1	Low-voltage switchgear and controlgear - Part 1: General rules
	GB/T14048.4	Low-voltage switchgear and controlgear – Part 4-1: Contactors and motor starters – Electromechanical contactors and motor starters
	GB/T14048.5	Low-voltage switchgear and controlgear – Part 5-1: Control circuit devices and switching element – Electromechanical control circuit devices
Standards for ATEX	IEC / EN 60079-0	Explosive atmospheres – Part 0: Equipment - General requirements
	IEC / EN 60079-1	Explosive atmospheres – Part 1: Equipment protection by flameproof enclosures "d"
	IEC / EN 60079-7	Explosive atmospheres – Part 7: Equipment protection by increased safety "e"
	IEC / EN 60079-14	Explosive atmospheres – Part 14: Electrical installations design, selection and erection
	IEC / EN 60079-31	Explosive atmospheres - Part 31: Equipment dust ignition protection by enclosure "t"

NOTES

A large rectangular area filled with a grid of small, evenly spaced dotted lines, intended for handwritten notes. The grid covers most of the page below the title.

02

The background features a subtle grid pattern that is more pronounced on the right side. A color gradient is applied across the page, starting with a light, almost white tone at the top, transitioning through soft pinks and oranges on the left, and ending in a deep blue on the right. The overall aesthetic is clean and modern.

GENERAL PRODUCT OVERVIEW CONTACTORS

2/2 Basic function

2/10 Terms and ratings

2/11 Product range

GENERAL PRODUCT OVERVIEW CONTACTORS

Basic function

Contactors are electromagnetically operated switches. The functional principle can be described as follows: when control power flows through the magnet coil of a contactor, the resulting magnetic field attracts the mechanical contact carrier. By interruption of the coil control circuit, the mechanical contact carrier returns to the starting position.

ABB contactors are provided in either three or four power pole configurations with a variety of accessories, including auxiliary contacts, easy connecting links (between products), interlocks, and bus bars. Contactors are primarily used for controlling single and three-phase motors and switching power circuits.

The ABB contactors belong to the class of air-break contactors. If coil power is removed, an arc is created as the contacts open. Air-break contactors extinguish the arc by having a sufficient distance separating the contacts.

Contactors are approved according to IEC / EN 60947-4-1, IEC / EN 60947-5-1. and contactor relays are approved according to IEC / EN 60947-5-1. The basic function is realized with the following sub functions:

Contactors together with CA4, CAT4 or CAL4 accessories:

- mechanically contact elements
- mirror contacts

Contactors relays together with CA4 or CAL4 accessories:

- mechanically contact elements

Below some examples:

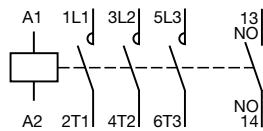

3-pole contactor

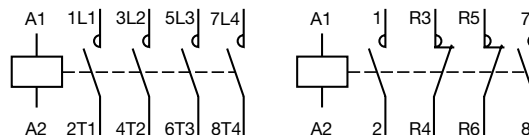

4-pole contactor 4N.O. or 2 NO + 2N.C

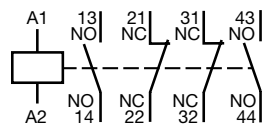

4-pole contactor relay (e.g. NF..22E)

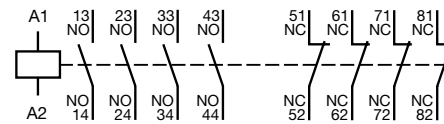

8-pole contactor relay (e.g. NF..44E)

Note: More details about mechanically linked contacts and mirror contacts look in to chapter: [Mechanically linked contacts or mirror contacts](#)

GENERAL PRODUCT OVERVIEW CONTACTORS

Structure of AF09 up to AF96

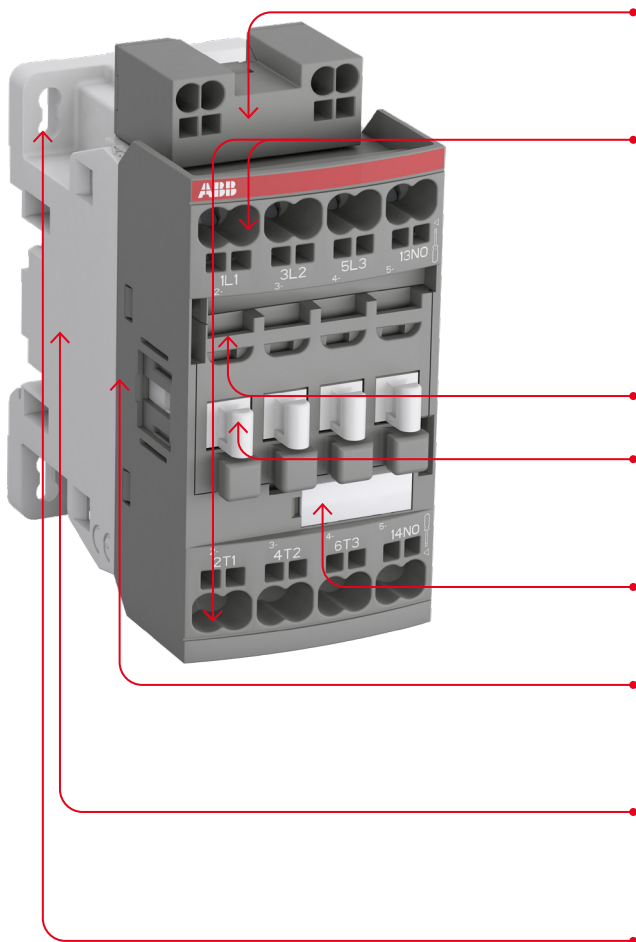

Coil terminals block

Can be pre-wired prior to installation and easily rotated from top (standard) to bottom.

Main pole terminals

Allow the connection of up to two conductors with different cross-sections for the main.

AF09 up to AF38 are available as screw terminals or push-in spring terminals.

AF40 up to AF96 are available as screw terminals.

Contacts for front-mounted coil terminal

Contact carrier

Linked to the coil positioning open or close, and leads the front-mounted accessories.

Function markers

Included as standard and available as an accessory.

Contact carrier for side

Linked to the coil positioning open or close, and leads the side-mounted accessories.

DIN mounting

Allows mounting of the device on DIN rails 35 × 7.5 mm, 35 × 15 mm or 75 mm.

Mounting hole pattern

GENERAL PRODUCT OVERVIEW CONTACTORS

Structure of AF116 up to AF146

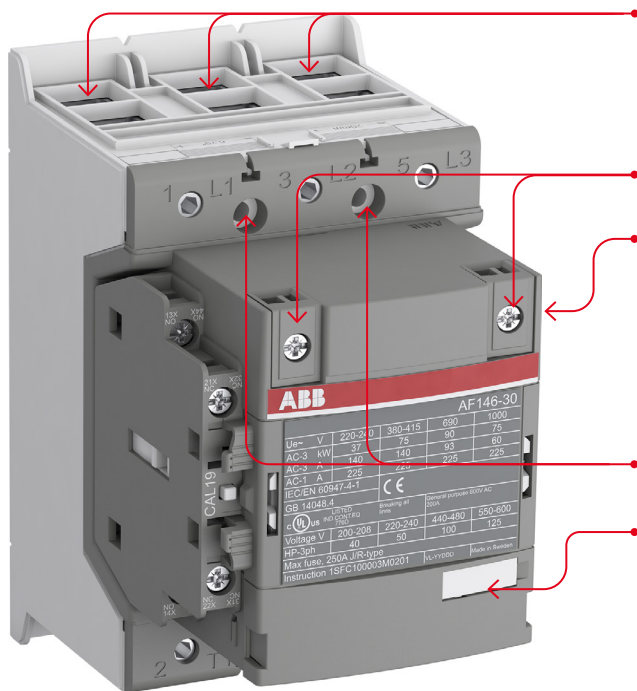

Power terminals

Main terminals of AF116 ... AF146 contactors are at the back of the contactors to facilitate your bus bar connections. AF116 up to AF145 are available as screw terminals or with screw.

Coil control terminals

2 side mounted auxiliary contact blocks

AF116 ... AF2850 contactors can take up to two side mounted auxiliary contact blocks without adding to its width. Coil connection terminals, mechanical and electrical interlocks and electronic timers are easily connected through the snap-to-connect function.

Mounting hole pattern

Function markers included as standard (available as an accessory)

ABB AF146-30

U _e - V	220-240	380-415	690	1000
AC-3 - kW	37	75	90	75
AC-3 - A	140	140	93	80
AC-1 - A	225	225	225	225

TEC/EN 60947-4-1
GB 19846.4
Voltage V
200-208 220-240 440-480 550-600
IP-30h
Max fuse: 250A UR500ps
Instruction ISFC100203M0201

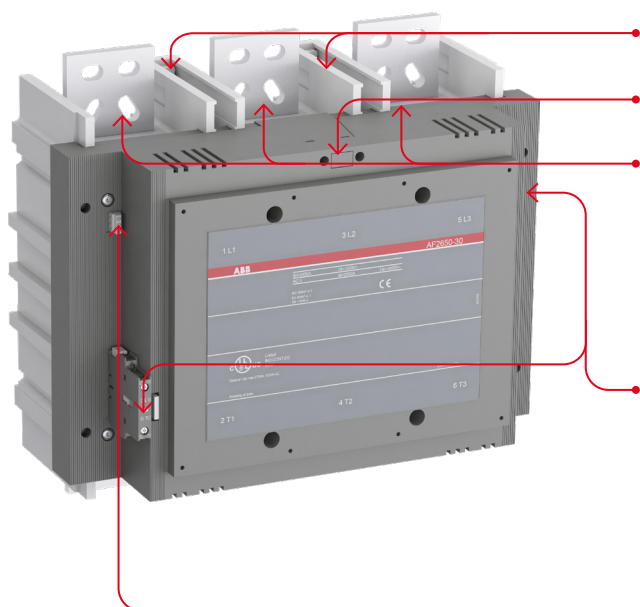
Structure of the AF146-B and AF190 up to AF2650**Mounting hole pattern****Coil control terminals****Power terminals**

Main terminals of AF116 ... AF2850 contactors are at the contactors' back to facilitate bus bar connections. It also allows easy contact inspection and maintenance from AF400 and above. AF146-B and AF190 up to A2850 are available as screw connection with connection rails.

2 side mounted auxiliary contact blocks

AF116 ... AF2850 contactors can take up to 2 side mounted auxiliary contact blocks without adding to its width. Coil connection terminals, mechanical and electrical interlocks and electronic timers are easily connected through the snap-to-connect function.

Built-in PLC interface

For control with 24 V DC \geq 10 mA PLC output. The built-in PLC interface operates the 100 up to 250 V AC / DC or 250 up to 500 V AC / DC AF contactor coil. Available for AF contactors from 55 kW – 400 V / 75 hp up to 560 kW – 400 V / 900 hp 480 V and up to 2850 A AC-1 / General use. Dedicated coil code from AF116 up to AF370 and standard feature from AF400 up to AF2850.

GENERAL PRODUCT OVERVIEW CONTACTORS

AF technology



Reliable in all networks

The electronic system within the AF contactor continuously monitors the current and voltage applied to the coil. The contactor is safely operated in an always optimized condition and hum-free.

AF coil

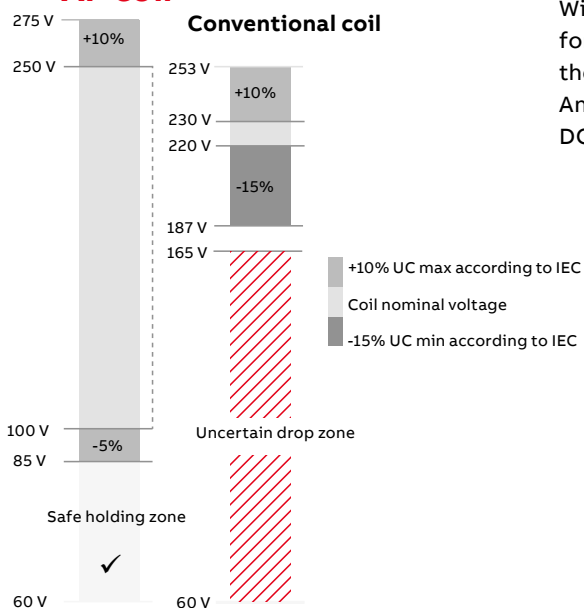

Wide control voltage range

With conventional contactor technology, different contactors are needed for different network voltages. Thanks to the wide operating range of the AF contactor, it can operate equally well in Europe as in Asia or North America. The core coil of the AF contactor range covers 100-250 V AC / DC, 50 / 60 Hz.

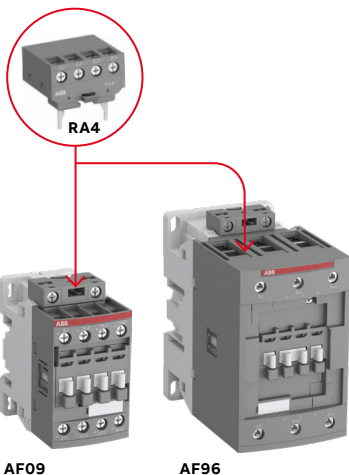

AF contactor <100 A coil interface for PLC

Coil interfaces are offered to operate all contactor with very low PLC output signals. They allow a galvanic isolation between the PLC circuit and the contactor coil circuit.

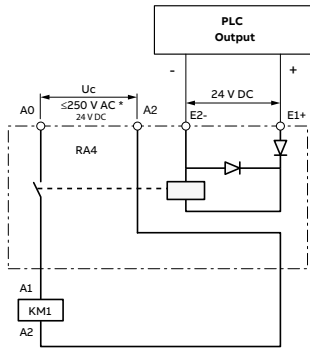

For control with 24 V DC ≥ 20 mA PLC output. RA4 interface relay can be used for rated control circuit voltages U_c 24 ... 250 V 50/60 Hz and 24 V DC with the standard AF contactors up to 45 kW - 400 V / 60 hp - 480 V and with NF contactor relays.

AF contactor >100 A general operating

AF Contactors >100 A are fitted with an electronic coil interface. For a given coil, this interface allows the contactor to accept a very wide voltage range. The contactor can also be controlled by separate logic control signals from for instance a PLC. The selection of the control method is done with switch S1. Control by switching voltage on A1 and A2 requires the switch in position B while control with logic signals requires the switch in position A.

Control by switching voltage on A1 and A2 (switch S1 in position B default factory setting)

The operation of AF contactors is the same as with conventional contactors: by applying and removing voltage on A1 and A2.

Control with logic control signals (switch S1 in position A)

The use of the logic control signals also requires a steady voltage on terminals A1 and A2 within the operational limits. The minimum pulse length for opening and closing is 7 msec. The function of the logic control signals will no longer be guaranteed when the logic on A1 and A2 is removed. The logic control signals operate with 24 V DC and consist of two control signals (ON and OFF_N) and a common reference (COM). To close the contactor, it is sufficient to have a control pulse at ON and to open its removal of voltage from OFF_N.

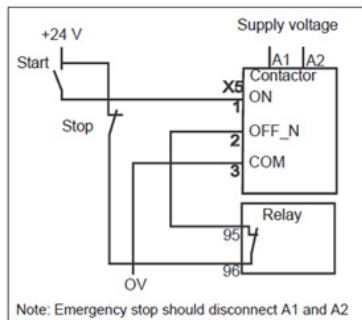

When used with switches the wiring can be done according to diagram above.

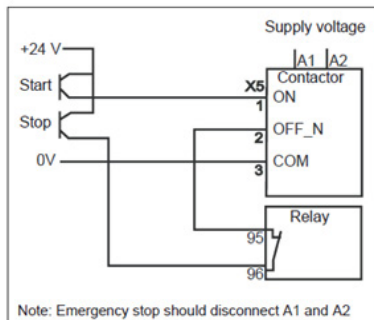

When used with transistor outputs the wiring can be done according to diagram above.

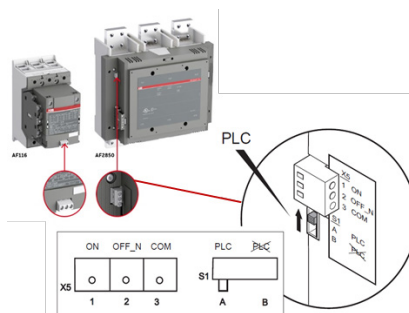
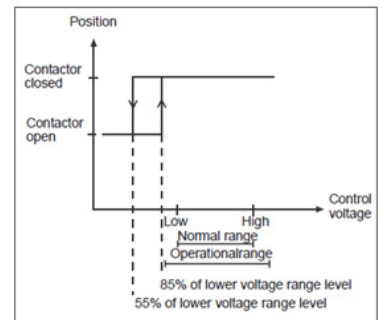

GENERAL PRODUCT OVERVIEW CONTACTORS

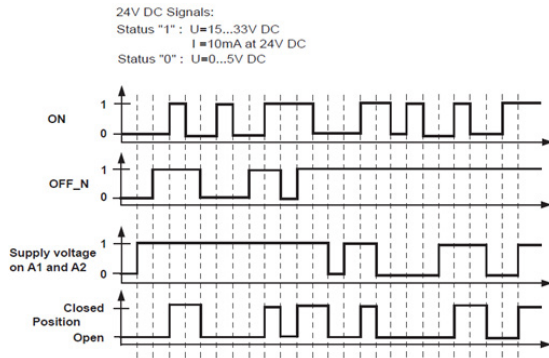

For control with 24 V DC ≥ 10 mA PLC output. The built-in PLC interface operates the 100 ... 250 V AC / DC or 250 ... 500 V AC / DC AF contactor coil. Available for AF contactors from 55 kW - 400 V / 75 hp up to 560 kW - 400 V / 900 hp 480 V and up to 2850 A AC-1 / General use. Dedicated coil code from AF116 up to AF370 and standard feature from AF400 up to AF2850.

The functions are described with the following diagram. "1" means 24 V DC between the control signal and COM, "0" means no voltage between the control signal and COM. The function is made so that ON and OFF_N can be connected in parallel for a common ON/OFF signal. In addition to these signals, the function limits for the supply voltage are still valid (closing at 77% and opening at 55%), which is indicated in the diagram by high and low voltage.

Protective separation

"Protective separation" or "Safe isolation" of circuits is ensured when a single failure does not result in a voltage from one circuit to another. Errors to be considered are, e.g. a bent solder pin, a bent or dissolved conductive part, a broken winding wire, the breakage of a partition within a device or a failed screw.

Protective separation between circuits within equipment is achieved by complying with the basic requirements set out in the regulation IEC / EN 60947-1, Annex N.

The main basic requirements are:

- Double or reinforced insulation
- Protective shield
- Combination of double or reinforced insulation and protective shielding

During the entire expected lifetime, the insulation must be resistant to aging. No safe separation will be required for circuits without safety extra-low voltage or without functional extra-low voltage.

The term protective separation is often closely linked in conjunction with functional extra-low voltage and protective extra-low voltage. The protective separation should reliably prevent the passage of a dangerous voltage to a safe separate voltage (i.e. to a safety extra-low voltage, which is connected or applied in the same device). In case the different voltages are operated on the current paths of a contactor, a "safe separation" must exist!

Mechanically linked contacts or mirror contacts

Mechanically linked contacts according to IEC / EN 60947-5-1 Annex L

Definitions of mechanically linked elements acc. to IEC 60947-5-1, Annex L. The combination of "n" Make auxiliary contact element(s) and "m" Break auxiliary contact element(s) is designed in such a way that they cannot be in the closed position simultaneously. One control circuit device may have more than one group of mechanically linked contact elements.

All ABB contactor relays (with at least one NC contact) have been tested in accordance with IEC 60947-5-1 and have had positively driven contact elements in the basic unit or in the basic unit in conjunction with auxiliary switches since the product was introduced.

Mirror contacts according to the IEC / EN 60947-4-1 Annex F

Definitions of mirror contact acc. to IEC 60947-4-1, Annex F 2.1. Normally closed auxiliary contact (N.C.) which cannot be in the closed position simultaneously with the normally open (N.O.) main contact.

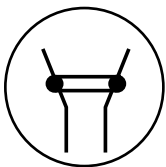

Electromagnetic compatibility

The definition for the AF... contactors that comply with IEC / EN 60947-1 and IEC / EN 60947-4-1 standards, are:

- Environment A: "Mainly relates to low-voltage non-public or industrial networks/locations/installations (EN 50082-2 article 4) including highly disturbing sources".
- Environment B: "Mainly relates to low-voltage public networks (EN 50082-1 article 5) such as residential, commercial and light industrial locations/installations. Highly disturbing sources such as arc welders are not covered by this environment".

Notice for AF09...AF2650 contactors:

- AF09 ... AF38 contactors and NF contactor relays (produced since week 08-2013), AF40 ... AF96 contactors have been Designed for environment B.
- AF09 ... AF38-...-12 contactors and NF..E-12 contactor relays (48...130 V 50/60 Hz-DC), AF116 ... AF2650 contactors: these products have been designed for environment A. The use of this product in environment B may cause unwanted electromagnetic disturbances in which case the user may be required to take adequate mitigation measures.

Note: for 48...130 V 50/60 Hz-DC in environment B, AF09Z ... AF38Z-...-22 contactor or NFZ..E-22 contactor relays can be selected.

SEMI F47 compliance

SEMI F47-0706 defines the voltage sag immunity required for semiconductor processing, metrology and automated test equipment, and on subsystems and components which are used in the construction of semiconductor processing equipment, including but not limited to:

- Power supplies
- Generators
- Robots and factory interface
- Chillers, pumps, blowers
- AC operated contactors and contactor relays

GENERAL PRODUCT OVERVIEW CONTACTORS

Terms and ratings

Circuits	<p>Auxiliary circuit All the conductive parts of a contactor designed to be inserted in a different circuit from the main circuit and the contactor control circuits.</p> <p>Control circuit All the conductive parts of a contactor (other than the main circuit and the auxiliary circuit) used to control the contactor's closing operation or opening operation or both</p> <p>Main circuit All the conductive parts of a contactor designed to be inserted in the circuit that it controls</p>
Coil operating range	Expressed as a multiple of the rated control circuit voltage U_c for the lower and upper limits.
Cycle time	<p>This is the sum of the current flow time and the no-current time for the given cycle.</p> <p>Electrical durability Number of on-load operating cycles that the contactor is able to carry out. It depends on the operational current, the operational voltage, and the utilization category.</p> <p>Mechanical durability Number of no-current operating cycles that a contactor is able to carry out</p>
Endurance / durability	<p>Electrical endurance The number of on-load operating cycles (i.e. with the current on the main contacts) a contactor can achieve, varies depending on the utilization category.</p> <p>Mechanical endurance The number of off-loading operating cycles (i.e. without current on the main contacts) a contactor can achieve.</p>
Load factor	Ratio of the on-load operating time to the total cycle time $\times 100$ (%).
Inching	Energizing a motor once or repeatedly for short periods to obtain small movements of the driven mechanism.
Intermittent duty	Duty in which the main contacts of a contactor remain closed for periods of time insufficient to allow the contactor to reach thermal equilibrium, the current-carrying periods being separated by off-load periods of sufficient duration to restore equality of temperature with the cooling medium.
Rated breaking capacity; Rated making capacity	Value of RMS current a contactor can break or make at a fixed voltage value, within the conditions specified by the standards, depending on the utilization category.
Rated control circuit voltage U_c	Control voltage value for which the control circuit of the unit is sized.
Rated insulation voltage U_i	Voltage value which designates the unit and to which dielectric tests clearance, and creepage distances refer.
Rated impulse withstand voltage U_{imp}	The highest peak value of an impulse voltage of prescribed form 1.2/50, which does not cause breakdown under specified test conditions.
Rated operating current I_e	Current value stated by the manufacturer and considering the rated operating voltage U_e , the rated frequency, the rated duty, the utilization category, the electrical contact life and the type of protective enclosure.
Rated operating voltage U_e	Voltage value to which utilization characteristics of the contactor refer, i.e. phase to phase voltage in 3-phase circuits.
Conventional thermal current I_{th}	Value of current the contactor can withstand with poles in closed position, in free air for an eight-hour period of duty without the temperature rise of its various parts exceeding the limits specified by the standards.
Making and breaking current	Current at contactor closing or opening.
Resistance to shocks	Requirements applicable that instance to vehicles, crane operation or switchgear slide-in module systems. At the quoted permissible "g" values, contactors must not undergo a change in switching state and overload relays must not trip.
Resistance to vibration	Requirements applicable to all the vehicles, vessels and other similar transport systems. At the quoted amplitude and vibration frequency values, the unit must be capable of achieving the required duty.
Times	<p>Closing time Time between energization of the coil and the moment the contacts of the first current path to be closed actually close.</p> <p>Opening time Time between de-energization of the coil until the moment when the contacts of the last current path to be opened are open.</p> <p>Minimal operation time Shortest control duration to ensure complete closing or opening of a contactor.</p> <p>Short time current permissible Value of current which the contactor can withstand in closed position for a short time period and within specified conditions.</p> <p>Time constant Ratio of inductance to the resistance: $L/R = \text{mH}/\text{Ohm} = \text{msec}$.</p> <p>Cycle duration Total time of the on-load + off-load period.</p>

Product range

Contactors for motor control and power switching AF

ABB's range of AF contactors is the industry benchmark. The integrated electronically controlled coil offers multiple benefits over conventional alternatives, and together with ABB's wide product range provides optimal configuration every time.

AF contactors are available as 3-pole contactors from 9 A up to 1060 A AC-3 or up to 2850 A AC-1, with AC / DC wide operational voltage range coils.

AF contactors are also available as 4-pole contactors from 25 A up to 525 A AC-1, with AC operational voltage coils, DC operational voltage range coils or AC / DC wide operational voltage range coils.



GENERAL PRODUCT OVERVIEW CONTACTORS

General overview motor protection and control

3-POLE CONTACTORS

CONTACTORS



IEC (1) AC-3 Rated operational power	$\theta \leq 60^\circ\text{C}$ (2), 400 V	4	5.5	7.5	11	15	18.5	18.5	22	30	37	45	55	75	75
UL/CSA 3-phase motor rating	480 V	5	7.5	10	15	20	25	30	40	50	60	60	75	100	100
AC / DC Control supply		AF09	AF12	AF16	AF26	AF30	AF38	AF40	AF52	AF65	AF80	AF96	AF116	AF140	AF146
AC Control supply		AF09	AF12	AF16	AF26	AF30	AF38	AF40	AF52	AF65	AF80	AF96	AF116	AF140	AF146
DC Control supply		AF09	AF12	AF16	AF26	AF30	AF38	AF40	AF52	AF65	AF80	AF96	AF116	AF140	AF146
IEC AC-3 Rated operational current	$\theta \leq 60^\circ\text{C}$ (2), 400 V	9	12	18	26	32	38	40	53	65	80	96	116	140	146
AC-1 Rated operational current	$\theta \leq 40^\circ\text{C}$, 690 V	25	28	30	45	50	50	70	100	105	125	130	160	200	225
UL/CSA General use rating	600 V	25	28	30	45	50	50	60	80	90	105	115	160	200	200
NEMA NEMA Size		00	0	—	1	—	—	2	—	—	3	—	—	4	—

1) 1000 V IEC ratings available for AF80, AF96 and AF146 ... AF2650 contactors.
 2) $\theta \leq 55^\circ\text{C}$ for mini contactors and AF400 ... AF2650 contactors.

MAIN ACCESSORIES

Auxiliary contact blocks	Front mounting	CA4-10 (1 x N.O.) CA4-01 (1 x N.C.)				
	Side mounting	CAL4-11 (1 x N.O. + 1 x N.C.)				CAL19-11 (1 x N.O. + 1 x N.C.)
Timers	Electronic	TEF4-ON TEF4-OFF				
Interlocking units (3)	Mechanical	VM4	VM96-4		VM19 (for same size contactors)	
	Mechanical / Electrical	VEM4				
Connection sets	For reversing contactors	BER16-4	BER38-4	BER65-4	BER96-4	BER140-4
Surge suppressors	Varistor (AC/DC)	Built-in surge protection				
	RC type (AC)					
	Transil diode (DC)					

3) See available reversing contactors VB6, VB7 and VAS09 ... VAS16.

OVERLOAD RELAYS

Thermal relays	Class 10 (Class 10A for TF140, TA200DU)	TF42 (0.10...38 A)		TF65 (22...67 A)	TF96 (40...96 A)	TF140DU (66...142 A) $\theta \leq 55^\circ\text{C}$
Electronic relays	Class 10E, 20E, 30E	EF19 (0.10...18.9 A)	EF19 (0.10...18.9 A) EF45 (9...45 A)	EF65 (20...70 A)	EF96 (20...100 A)	EF146 (54...150 A)
Accessories (for single mounting)	Thermal relays	DB42		DB65 (only for TF65)	DB96	
	Electronic relays	DB19EF	DB45EF		DB96	



90	110	132	160	200	200	250	315	400	—	475	560	—	—	—
125	150	200	250	300	350	400	500	600	—	800	900	—	—	—
AF190	AF205	AF265	AF305	AF370	AF400	AF460	AF580	AF750	AF1250	AF1350	AF1650	AF2050	AF2650	AF2850
AF190	AF205	AF265	AF305	AF370	AF400	AF460	AF580	AF750	AF1250	AF1350	AF1650	AF2050	AF2650	AF2850
AF190	AF205	AF265	AF305	AF370	AF400	AF460	AF580	AF750	AF1250	AF1350	AF1650	AF2050	AF2650	AF2850
190	205	265	305	370	400	460	580	750	—	860	1060	—	—	—
275	350	400	500	600	600	700	800	1050	1260	1350	1650	2050	2650	2850
250	300	350	400	520	550	650	750	900	1210	1350	1650	2100	2700	2850
—	—	5	—	—	—	6	—	7	—	—	8	—	—	—

CAL18-11 (1 x N.O. + 1 x N.C.)

VM750H
VM750V

VM1650H

BER205-4

BER370-4

BEM460-30

BEM750-30

TA200DU (66...200 A)
 $\theta \leq 55^\circ\text{C}$

EF205
(63...210 A)
DB200

EF370 (115...380 A)

EF460
(150...500 A)

EF750
(250...800 A)







EF1250DU
(350...1250 A)

More information about ABB contactors is easily accessible at ABB's Download Center (<https://library.abb.com>). All Categories > Products > Low Voltage Products and Systems > Control Product > Contactors

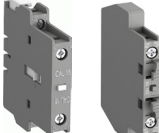
GENERAL PRODUCT OVERVIEW CONTACTORS

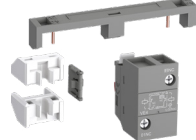
Accessories

Since contactors combine the functions of multiple components, they are offered with many of the same types of accessories. Thus, the contactors can be extended with auxiliary contacts, which can be connected either on the side or – especially space-saving – on the front. Also, an electronic timer is available, and mechanical and electrical interlock sets complement the product range. Compact starter combinations can be easily and quickly built with the aid of separately available direct adapters.

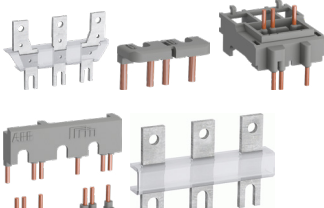
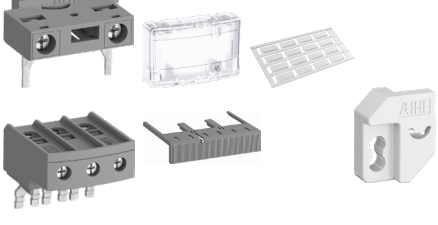
Auxiliary contact blocks for AF09 ... AF96 NF	Auxiliary contact blocks CA4, CC4, CAT4, CAL Auxiliary contact blocks with push-in spring terminals CA4..K, CAL4..K Auxiliary contact blocks for demanding industrial environments CE5	
Auxiliary contact blocks for AF116 ... AF2850	CAL19: AF116...AF370 CAL18: AF400...AF2850 CEL19: AF116...AF370 CEL18: AF400...AF2850	
Electronic timers	Electronic timers TEF4 Electronic timers with spring terminals TEF4-S	
Interlocks	Mechanical interlock units VM Mechanical and electrical interlock sets VEM4, VEM4K	
Impulse contact blocks	Impulse contact block CB5	
Interface relays	Interface relays RA4	
Mechanical latching units	Mechanical latching unit WA4	
Connections	Terminal enlargements LW Terminal extension LX Connection sockets LL Terminal connecting strips and shorting bars LY, LP, LH, LF, LG Connection accessories for starting solutions BEA Connection sets for reversing contactors BER, BEM Connection sets for star-delta starter BEY, BED Phase-to-phase connection BEP, BES	
Other accessories	Additional coil terminal blocks LDC4, LDC4K Protective covers BX4 Function markers BA Mounting piece BP Additional terminal blocks LD38 Terminal shrouds LT	

Main accessory fitting details for AF09 ... AF96 3-pole contactors

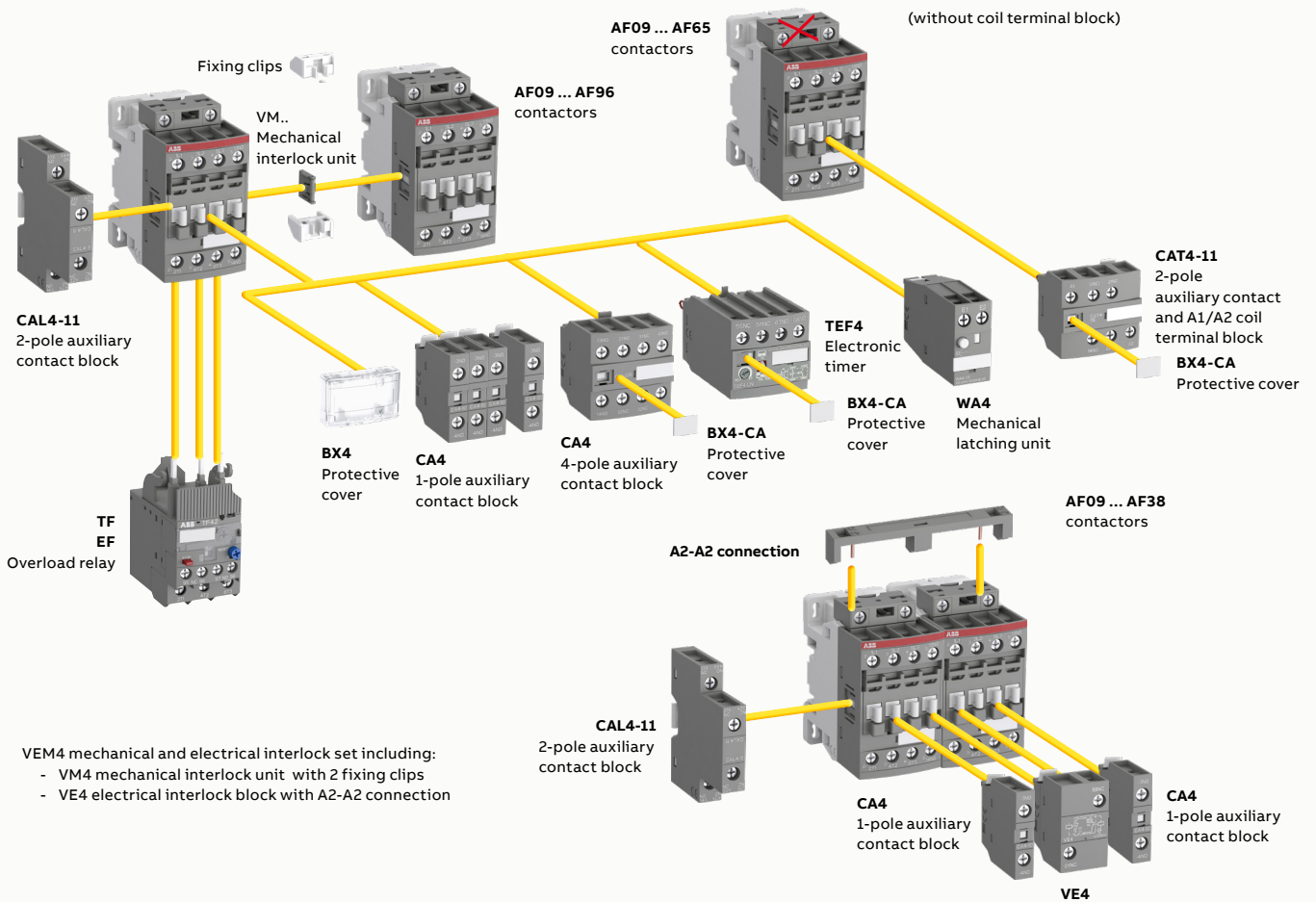

MAIN ACCESSORY FITTING DETAILS

Many configurations of accessories are possible depending on whether they are front-mounted or side-mounted.

Contactor types	Main poles	Built-in auxiliary contacts	Front-mounted accessories					Side-mounted accessories				
			Auxiliary contact blocks			Electronic timer	Mechanical latching unit	Electrical and mechanical interlock set (between 2 contactors)	Auxiliary contact blocks 2-pole CAL4-11			
			1-pole CA4	2-pole CAT4-11	4-pole CA4	TEF4	WA4 ⁽²⁾	VEM4	Left side	Right side		
AF09(Z) ... AF38(Z)⁽¹⁾												
AF09 ... AF16	3	0	0	1	4 max.	or 1	or 1	or 1	or 1	-	+ 1	-
AF09 ... AF16	3	0	1	0	2 max.	or 1	-	or 1	or 1	-	+ 1	+ 1
AF26 ... AF38	3	0	0	0	3 max.	-	-	-	-	+ 1 ⁽³⁾	+ 1	or 1
AF09Z ... AF38Z 24 V DC designed for PLC - coil 30⁽¹⁾												
AF09Z ... AF16Z	3	0	0	1	4 max.	-	or 1	or 1	-	- ⁽³⁾	or 1	+ 1
AF09Z ... AF16Z	3	0	1	0	2 max.	-	-	or 1	-	- ⁽³⁾	+ 1	or 1
AF26Z ... AF38Z	3	0	0	0	-	-	-	1	-	-	+ 1	+ 1
AF40 ... AF96												
AF40 ... AF65	3	0	0	0	4 max.	or 1	or 1	or 1	or 1	-	+ 1	+ 1
AF80, AF96	3	0	0	0	4 max.	-	or 1	or 1	or 1	-	+ 1	+ 1

1) Including add-on and built-in contacts : 4 N.C. auxiliary contacts max. on positions 1, 2, 3, 4 and 3 N.C. auxiliary contacts max. on positions 1 ±30°, 5.

2) Use WA4 for AF09...AF65 and WA4-96 for AF80, AF96.

Accept 1-pole CA4 auxiliary contacts (1 block on each side of the mechanical latch) in respect to the total number of built-in or additional N.C. auxiliary contacts. For WA4 accessory use with contactor coil 30, please consult your ABB local sales organization.

3) VEM4 not suitable for AF..Z contactors with DC control voltages 12...20 V DC (coil 20) and 24 V DC (coil 30). Use VM4 side-mounted mechanical interlock unit.

GENERAL PRODUCT OVERVIEW CONTACTORS

Main accessory fitting details for AF09..K ... AF38..K 3-pole contactors – with push-in spring terminals

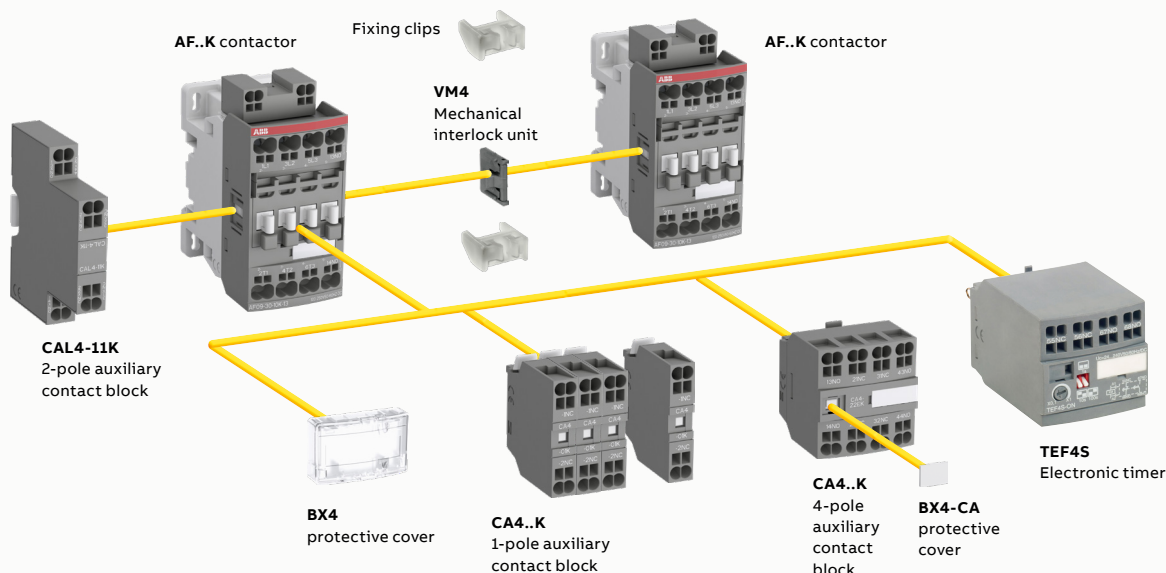

MAIN ACCESSORY FITTING DETAILS

Many configurations of accessories are possible depending on whether they are front-mounted or side-mounted.

Contactor types	Main poles	Built-in auxiliary contacts	Front-mounted accessories				Side-mounted accessories	
			Auxiliary contact blocks		Electronic timer	Mechanical interlock unit (between 2 contactors)	Auxiliary contact blocks 2-pole CAL4-11K	
			1-pole CA4..K	4-pole CA4..K	TEF4S	VM4	Left side	Right side
AF09(Z)..K ... AF38(Z)..K ⁽¹⁾								
AF09..K ... AF16..K	3	0 0 1	4 max.	or 1	or 1	-	+	1 -
AF09..K ... AF16..K	3	0 1 0	2 max.	-	or 1	-	+	1 +1
AF26..K ... AF38..K	3	0 0 0	4 max.	or 1	or 1	+1	+	1 or 1
AF09Z..K ... AF38Z..K 24 V DC designed for PLC - coil 30 ⁽¹⁾								
AF09Z..K ... AF16Z..K	3	0 0 1	4 max.	or 1	or 1	+1	or	1 +1
AF09Z..K ... AF16Z..K	3	0 1 0	2 max.	-	or 1	+1	+	1 or 1
AF26Z..K ... AF38Z..K	3	0 0 0			1	-	+	1 +1

1) Including add-on and built-in contacts: 4 N.C. auxiliary contacts max. on positions 1, 2, 3, 4 and 3 N.C. auxiliary contacts max. on positions 1 ±30°, 5.

Main accessory fitting details for NF 4-pole contactor relays

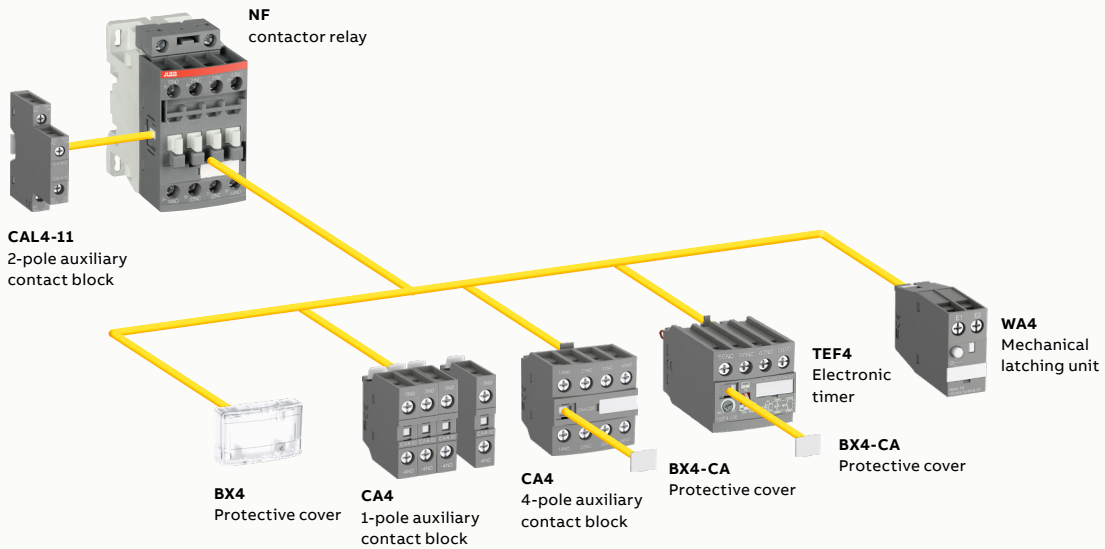

MAIN ACCESSORY FITTING DETAILS

Many configurations of accessories are possible depending on whether they are front-mounted or side-mounted.

Contactor types	Main poles	Built-in auxiliary contacts	Front-mounted accessories				Side-mounted accessories				
			Auxiliary contact blocks		Electronic timer	Mechanical interlock unit (between 2 contactors)	Auxiliary contact blocks 2-pole CAL4-11K				
			1-pole CA4..K	4-pole CA4..K	TEF4S	VM4	Left side	Right side			
AF09(Z)..K ... AF38(Z)..K ⁽¹⁾											
AF09..K... AF16..K	3	0	0	1	4 max.	or 1	-	+	1	-	
AF09..K... AF16..K	3	0	1	0	2 max.	-	or 1	-	+	1	+ 1
AF26..K... AF38..K	3	0	0	0	4 max.	or 1	or 1	+ 1	+	1	or 1
AF09Z..K ... AF38Z..K 24 V DC designed for PLC - coil 30 ⁽¹⁾											
AF09Z..K... AF16Z..K	3	0	0	1	4 max.	or 1	or 1	+ 1	or	1	+ 1
AF09Z..K... AF16Z..K	3	0	1	0	2 max.	-	or 1	+ 1	+	1	or 1
AF26Z..K... AF38Z..K	3	0	0	0			1	-	+	1	+ 1

1) Including add-on and built-in contacts: 4 N.C. auxiliary contacts max. on positions 1, 2, 3, 4 and 3 N.C. auxiliary contacts max. on positions 1 ±30°, 5.

GENERAL PRODUCT OVERVIEW CONTACTORS

Main accessory fitting details for NF..K 4-pole contactor relays – with push-in terminals

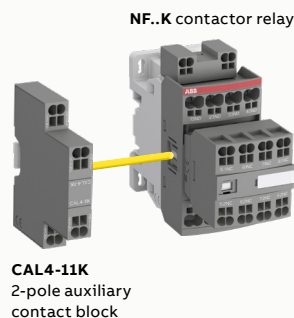
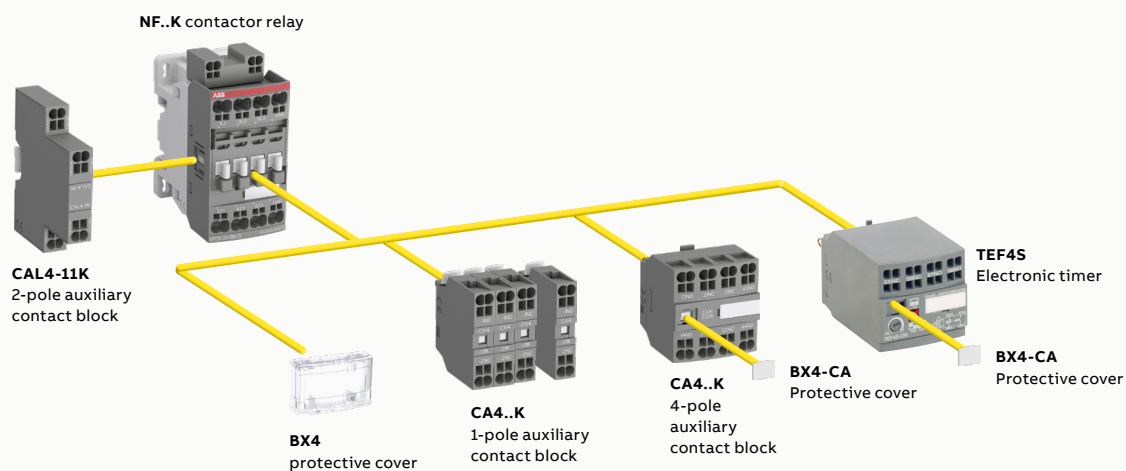

MAIN ACCESSORY FITTING DETAILS

Many configurations of accessories are possible depending on whether they are front-mounted or side-mounted.

Contactor relay types	Main poles	Front-mounted accessories			Side-mounted accessories		
		Auxiliary contact blocks		Electronic timer	Auxiliary contact blocks		
		1-pole CA4..K	4-pole CA4..K	TEF4S	Left side	Right side	
NF(Z)							
NF	2 2 EK ⁽¹⁾	4 max.	or 1	or 1	+	1	-
	3 1 EK ⁽¹⁾	2 max.	-	or 1	+	1	+ 1
	4 0 EK ⁽²⁾						
NF	4 4 EK	-	-	-	+	1	-
	5 3 EK						
	6 2 EK						
	7 1 EK						
	8 0 EK						
NFZ 24 V DC designed for PLC - coil 30							
NFZ	2 2 EK ⁽¹⁾	4 max.	or 1	or 1	or	1	+ 1
	3 1 EK ⁽¹⁾	2 max.	-	or 1	+	1	
	4 0 EK ⁽²⁾			1	+	1	+ 1
NFZ	4 4 EK	-	-	-	-	-	-
	5 3 EK						
	6 2 EK						
	7 1 EK						
	8 0 EK						

1) Including add-on contacts: 3 N.C. max. on positions 1, 2, 3, 4 and 2 N.C. max. on positions 1 ±30°, 5.

2) Including add-on contacts: 4 N.C. max. on positions 1, 2, 3, 4 and 3 N.C. max. on positions 1 ±30°, 5.

Main accessory fitting details for AF116 ... AF370 3-pole contactors

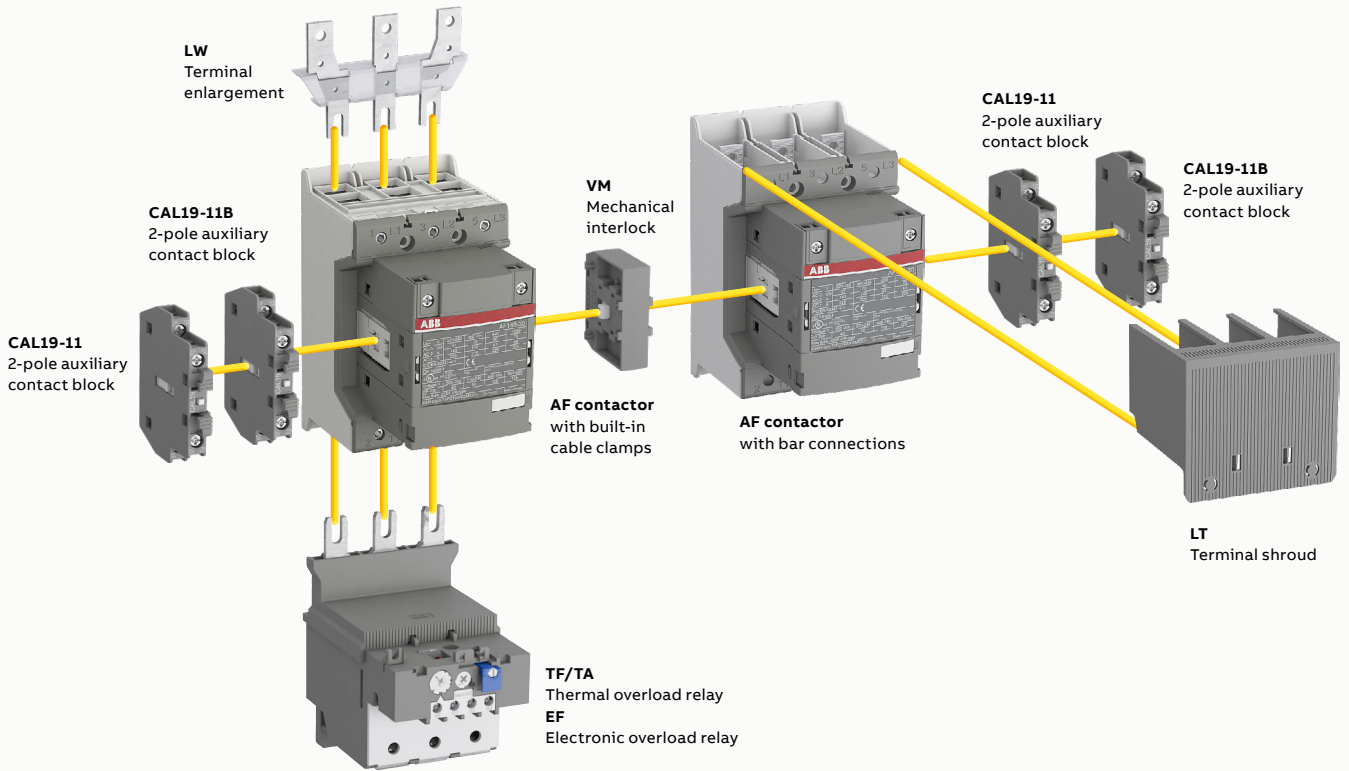

MAIN ACCESSORY FITTING DETAILS

Contactor types	Main poles	Available auxiliary contacts	Side-mounted accessories		Mechanical interlock units (between two contactors)
			Auxiliary contact blocks		
			CAL19-11 ⁽³⁾	CAL19-11B	
AF116 ... AF370	3	0 0 0	▶ 2 × CAL19-11	+ 2 × CAL19-11B	–
AF116 ... AF370	3	0 0 0	▶ 2 × CAL19-11 ⁽¹⁾	+ 2 × CAL19-11B ⁽¹⁾	+ VM... ⁽²⁾

1) Total number of auxiliary contact blocks for the two contactors.

2) Interlock type, according to the contactor ratings (see the accessories section).

3) The CEL19 auxiliary contact blocks can replace the CAL19-11 and CAL19-11B. However, no auxiliary contact block can be mounted outside the CEL19.



GENERAL PRODUCT OVERVIEW CONTACTORS

Main accessory fitting details for AF400 ... AF2850 3-pole contactors

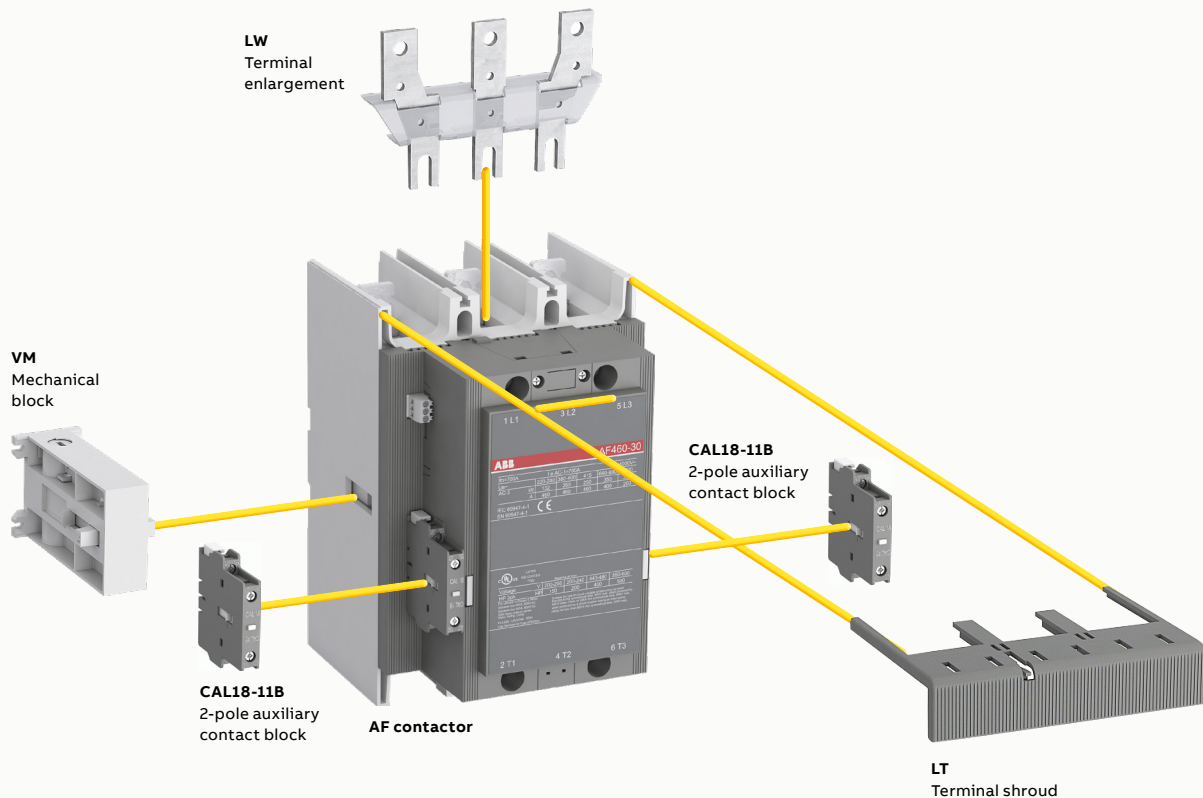
Main accessories (other accessories available)

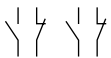

MAIN ACCESSORY FITTING DETAILS

Contactor types	Main poles	Available auxiliary contacts	Side-mounted accessories Auxiliary contact blocks	Mechanical interlock units (between two contactors)			
			 CAL18-11	 CAL18-11B ⁽³⁾			
CONTACTORS + AUXILIARY CONTACT BLOCKS							
AF400 ... AF2850	3	0	1	1	1 × CAL18-11	+ 2 × CAL18-11B	–
CONTACTORS WITH MECHANICAL INTERLOCKING + AUXILIARY CONTACT BLOCKS							
AF400 ... AF2850	3	0	1	1	2 × CAL18-11 ⁽¹⁾	+ 4 × CAL18-11B ⁽¹⁾	+ VM...H ⁽²⁾

1) Total number of auxiliary contact blocks for the two contactors.

2) Interlock type, according to the contactor ratings (see the accessories section).

3) The CEL18-... auxiliary contact blocks can replace the CAL18-11 and CAL18-11B. However, no auxiliary contact block can be mounted outside the CEL18-...

Mounting instructions for accessories for AF09 ... AF96

Auxiliary contacts

The auxiliary contact blocks are used for the operation of auxiliary circuits for standard industrial environments. Auxiliary contacts are available in various versions as normally open contacts or normally closed contacts. From the designation of the auxiliary contact, it can be seen whether it acts as an NC or NO contact. Types of auxiliary contact blocks for front mounting:

- 1 or 4-pole block, with instantaneous N.O., N.C. contacts [CA4, CA4-K]
- 1-pole block, with N.O. leading contact or N.C. lagging contact [CC4]
- 2-pole block, with instantaneous N.O. + N.C. contacts and A1 / A2 coil terminal connection on front face [CAT4]
- 1-pole block, instantaneous with N.O. contact or N.C. contact, available in 2 IP degrees
 - with built-in microswitch IP40, degree of protection (IP20 on terminals) [CE5-D]
 - with built-in microswitch IP67, degree of protection (IP20 on terminals) [CE5-W]

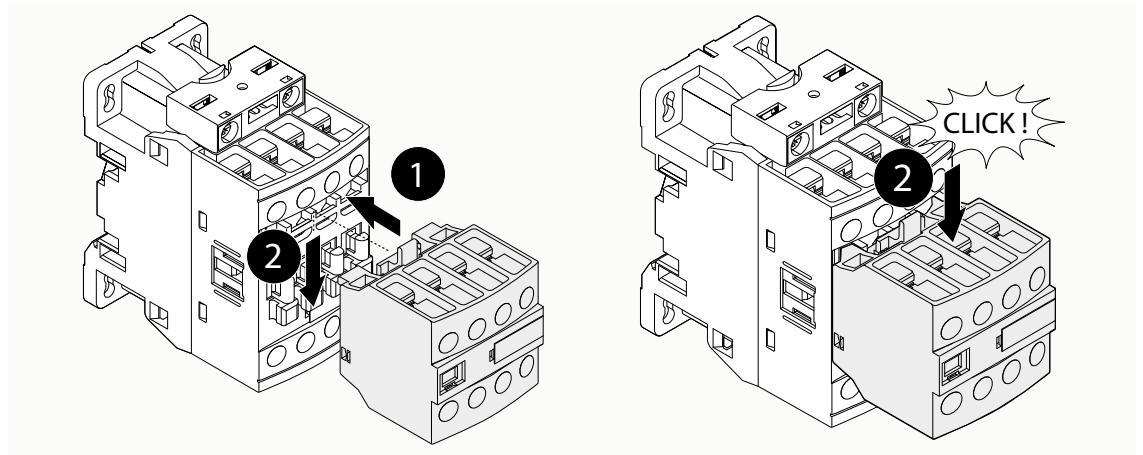

Select the 4-pole auxiliary contact blocks CA4-..E, CA4-..M, CA4-..U or CA4-..N type, according to the contactor or contactor relay type for compliance with the standard requirements.

Types of auxiliary contact blocks for side mounting:

- 2-pole block, with instantaneous N.O. + N.C. contacts [CAL4, CAL4-K, CAL18]
- 1-pole block, with built-in microswitch IP67 degree of protection (IP20 on terminals). Instantaneous N.O. or N.C. contact [CEL]

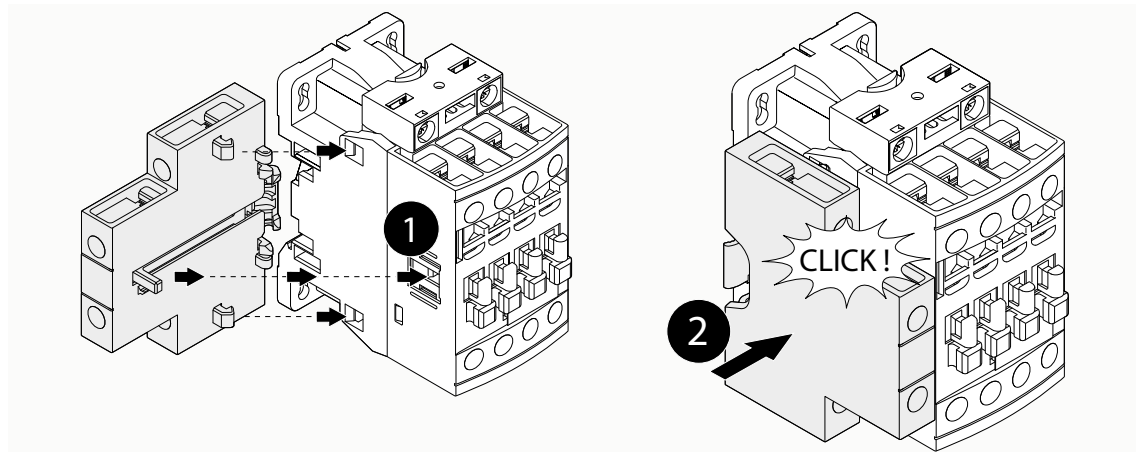

For clipping onto the right- and/or left-hand side of the contactors. The auxiliary contact blocks are equipped with screw-type connecting terminals delivered open, protected against accidental direct contact and bearing the corresponding function marking.

GENERAL PRODUCT OVERVIEW CONTACTORS

Electronic timers TEF4

This front-mounted electronic timers are used for realizing timing function and are available in ON-delay and OFF-delay versions. A mechanical indicator allows us to show the state of the contactor. TEF4 electronic timers are supplied by a direct plug-in parallel connection to the coil suppress terminals. A1 - A2 of the contactor or contactor relay. A varistor is integrated on the timer to offer built-in protection against surges in the contactor coil.

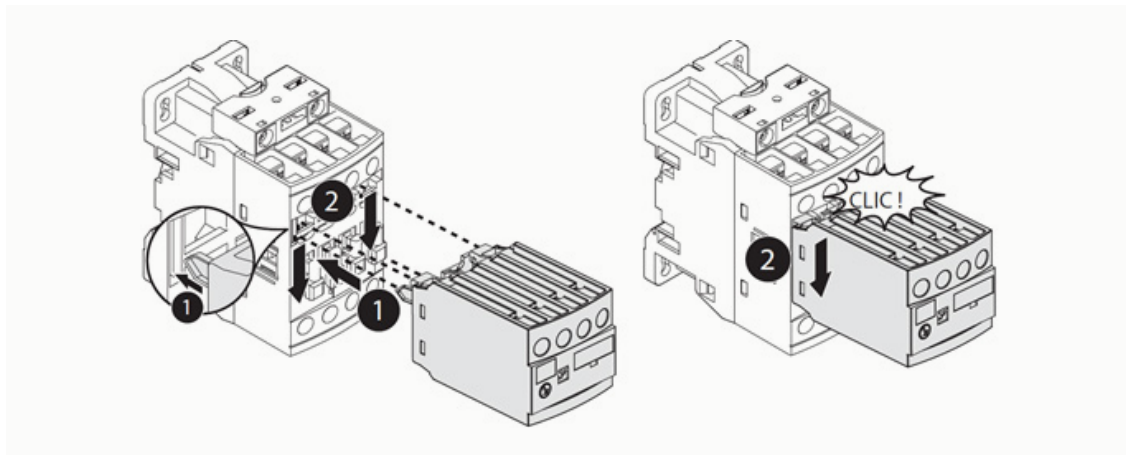

Interlock units

Mechanical interlock units VM4 and VM96-4

The VM mechanical interlock units are designed for the interlocking of two AF contactors. When mounted between two contactors, the VM mechanical interlock unit prevents one of the contactors from closing as long as the other contactor is closed. The mechanical interlock units VM4 and VM96-4 include two fixing clips (BB4).

Mechanical and electrical interlock sets VEM4

VEM4 mechanical and electrical interlock set for the interlocking of two AF contactors. VEM4 set includes a mechanical interlock unit VM4 with 2 fixing clips (BB4) and a VE4 electrical interlock block with A2-A2 connection. Fixing the electrical interlock block to the contactor front face connects the two built-in N.C. interlocking contacts with the two coils. VE4 block must be used with the A2-A2 connection to correspond to the electrical connection diagram.

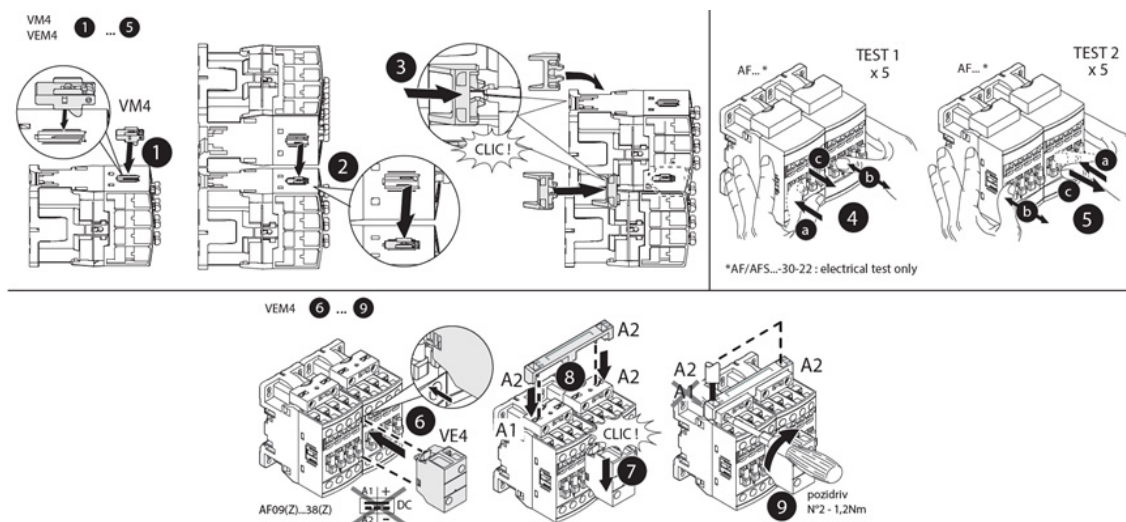

Impulse contact block CB5

Impulse contact blocks are designed for use in enclosures, in association with an adjustable mechanical pushbutton. Two types are available:

- CB5-10: N.O. contact with a black actuator ("ON" function)
- CB5-01: N.C. contact with a light grey actuator ("OFF" function).

These blocks are equipped with two connecting leads 0.5 mm² with end, approximately 18 cm long. Mounting: clipped onto the front face of the contactors, like the front mounting auxiliary contacts (chapter 2.3.2.4).

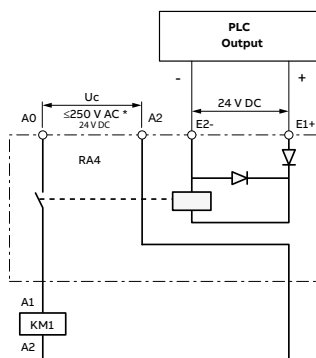

Interface relay RA4

The RA4 interface relay is designed to receive 24 V DC signals delivered by PLCs or other sources with a low output power and to restore them with sufficient power to operate the coils of the relevant AF09 ... AF96 contactors or the NF contactor relays. The RA4 interface relay is made up of a miniature electromechanical relay equipped with an N.O. contact and with a low consumption 24 V DC coil.

The interface relay coil is controlled by the PLC while the N.O. contact ensures switching of the power contactor.

Coil switching gives rise to overvoltages that have adverse effects on the electronic devices, insulators and, more generally, on component lifetime. The RA4 is protected from surge thanks to the built-in surge protection of AF09 ... AF96. Furthermore, the RA4 is protected against relay pole reversal by a diode inserted between the E1 and E2 input terminals.

Connection

The E1+ and E2- input terminals must be connected, according to their polarity, to the PLC output. The RA4 is equipped with two terminal pads for connection to the A1 and A2 terminals of the contactor coil. This coil is supplied between the A0 and A2 terminals of the RA4.

Mounting

Remove the coil terminal block from the contactor and clip the interface relay without any screwing operation.

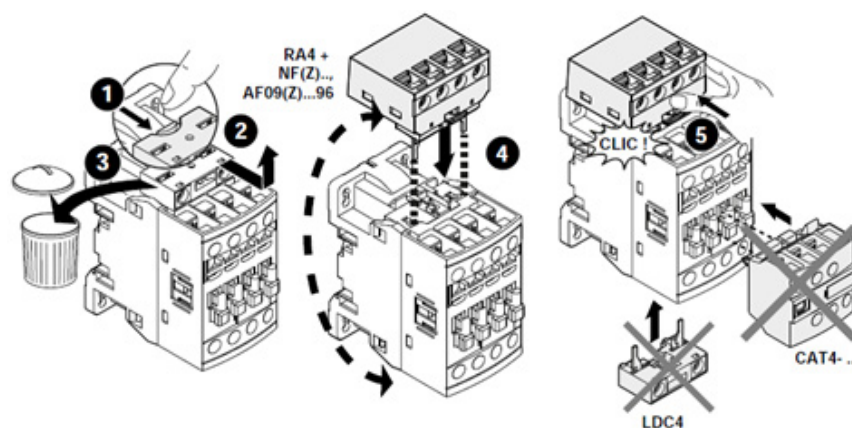

GENERAL PRODUCT OVERVIEW CONTACTORS

Mechanical latching WM4

The WA4 mechanical latching unit for AF09 ... AF96 contactors and NF contactor relays ensures that the contactor or contactor relay remains switched on a voltage failure. Standard contactors can be easily converted to compact latched contactors. The WA4 block contains a mechanical latching device with electromagnetic impulse unlatching (AC or DC) or manual unlatching.

Operation

After closing, the contactor continues to be held in the closed position by the latching mechanism should the supply voltage fail at the contactor coil terminals.

Contactor opening can be controlled:

- electrically by an impulse (AC or DC) on the WA4 block coil (the coil is not designed to be permanently energized)
- manually by pressing the pushbutton on the front face of the WA4 block

Mounting

The WA4 block is clipped onto the front face of the 1-stack contactor where it takes up two slots in the central position. The two other slots may accept CA4 single-pole auxiliary contacts (1 block on each side of the mechanical latch).

Additional CAL4 can be fitted on the side of the contactor with respect to the total number of built-in or additional N.O. and N.C. auxiliary contacts as described in the accessory fitting details part of each contactor type.

Connecting links with manual motor starters BEA

The BEA insulated 3-pole connecting links are used to connect AF09 ... AF65 contactors with the MS116 or MS132 or MS165 manual motor starters. The BEA insulated 3-pole connecting links ensure the electrical and mechanical connection between the contactor and the associated manual motor starter. BPR65-4 35 mm rail hooks used with BEA65-4 connecting link, allow direct mounting on two rails 35 mm of MS165 manual motor starters with AF40 ... AF65 contactors (for AF<100A BEA bus links are used for connection between contactor and breaker).

Connection sets for reversing contactors BER and BEM

The BER and BEM connection sets are used to connect the main poles of two 3-pole contactors mounted side by side. The BER connection sets are made up of one upstream and one downstream connection. The BEM connection sets are made up of three upstream and three downstream connections. BER and BEM connection sets are insulated and made of solid copper bars.

Phase-to-phase connections BEP and BES

The BEP and BES connection sets are used to connect phase-to-phase the main poles of two contactors mounted side by side; 4-pole contactors will then operate as source reversing contactors. The BEP connection sets are made up of one upstream or downstream connections. The BES connection sets are made up of three upstream or downstream connections. BEP and BES connection sets are insulated and made of solid copper bars.

Mounting instructions for accessories for AF116 ... AF370

Types of auxiliary contact blocks for side mounting:

- 2-pole block, with instantaneous N.O. + N.C. contacts [CEL19-11]
- 1-pole block, with instantaneous N.O. [CEL19-10] or N.C. [CEL19-01] contacts

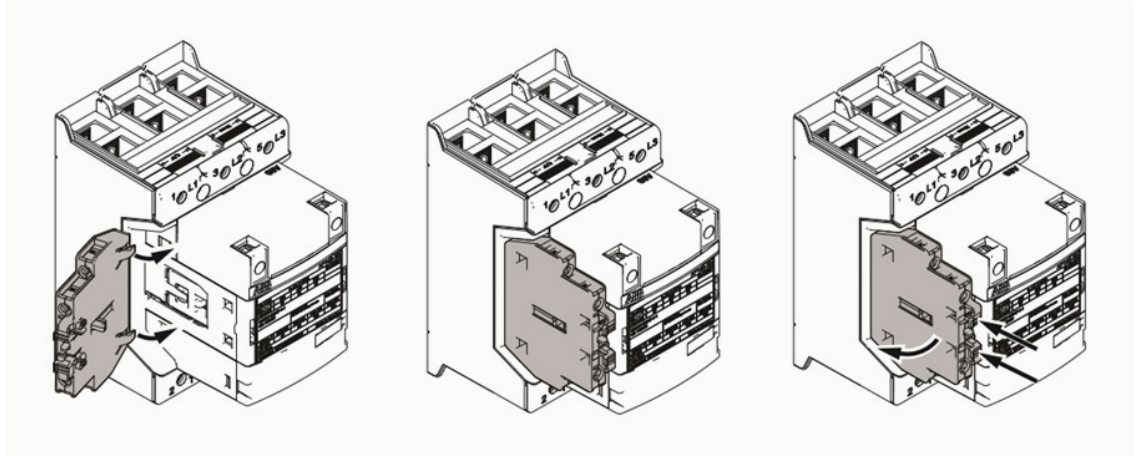

For clipping onto the right- and/or left-hand side of the contactors. The auxiliary contact blocks are equipped with screw-type connecting terminals delivered open, protected against accidental direct contact and bear the corresponding function marking.

Mechanical interlock units VM19

The VM mechanical interlock units are designed for the interlocking of two AF contactors. When mounted between two contactors, the VM mechanical interlock unit prevents one of the contactors from closing as long as the other contactor is closed.

MECHANICAL INTERLOCK UNITS FOR TWO CONTACTORS MOUNTED SIDE BY SIDE

AF116 ... AF146 AF190, AF205 AF265 ... AF370	VM19
AF116 ... AF146 and AF190, AF205	VM140/190
AF190, AF205 and AF265 ... AF370	VM205/265
AF265 ... AF370 and AF400 ... AF460	VM370/400

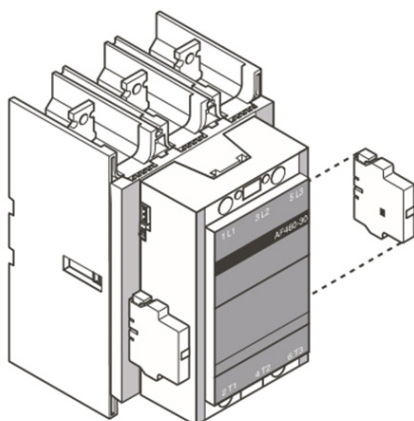

Mounting instructions for accessories for AF400 ... AF2850

Types of auxiliary contact blocks for side mounting:

- 2-pole block, with instantaneous N.O. + N.C. contacts [CAL18-11]

For clipping onto the right- and/or left-hand side of the contactors. The auxiliary contact blocks are equipped with screw-type connecting terminals delivered open, protected against accidental direct contact and bear the corresponding function marking.

GENERAL PRODUCT OVERVIEW CONTACTORS

Mechanical interlock units VM...

The VM mechanical interlock units are designed for interlocking two AF contactors. When mounted between two contactors, the VM mechanical interlock unit prevents one of the contactors from closing as long as the other contactor is closed.

MECHANICAL INTERLOCK UNITS VM...

Mechanical interlock units for two contactors mounted side by side

AF265 ... AF370 and AF400 ... AF460	VM370/400
AF400 ... AF1250	VM750H (PN.. mounting plate to be ordered separately)
AF1350 ... AF2650	VM1650H (Plate included)

Mechanical interlock units for two contactors mounted one above the other

AF400 ... AF1250	VM750V (Additional plate, not supplied)
------------------	---

Connections for AF116 ... 2850

Terminal enlargements LW

Enlargement pieces designed to increase the width of the contactor terminal pads to allow larger connections to be mounted.

Terminal extension LX

Extension pieces designed to extend the main terminals of contactors for combined mounting of contactors and connection sets.

Connection sockets LL

Connection socket can be used to replace built-in cable clamps in AF116 ... AF146.

Connection module LD146

The connection module can be fixed on AF116 ... AF146 delivered with bar terminals.

Terminal connecting strips and shorting bars LY, LP, LH, LF, and LG

Parallel and series connection of 3-pole contactors:

- To obtain a star point (3 parallel-connected poles)
- To connect poles in parallel and thus increase the AC load passing through the flow path made up of the parallel-connected poles: LP, LY, LH, LF, LG. The relevant cable cross-sectional area may limit the maximum permissible current.
- To connect poles in series and thus increase the DC voltage controlled by the poles: LP, LY (only LY16-4 and LY38-4 splittable strips).



03

The background features a subtle grid pattern that becomes more pronounced towards the right side. A color gradient is applied across the bottom half of the page, transitioning from a bright red on the left to a deep blue on the right, with a white-to-light blue gradient in the upper portion.

LOAD TYPES

- 3/2 General use and heaters**
- 3/2 Motors**
- 3/6 Hermetic refrigerant compressor motors**
- 3/11 DC switching applications**
- 3/12 Lamps and lighting loads**
- 3/13 Capacitors**
- 3/14 Overview of load types for contactors**

LOAD TYPES

ABB contactors are not only limited to one application, as they can be used for controlling different types of loads, such as motors, heaters, lights and so on. The table below shows the main ratings for ABB contactors.

Alternating current main ratings	Direct current main ratings
AC-1: Non-inductive or slightly inductive loads, resistance furnace	DC-1: Non-inductive or slightly inductive loads, resistance furnaces
AC-3: Squirrel-cage motors: starting, switching off motors during running, reversing	DC-3: Shunt motors: starting, plugging, inching, dynamic breaking of DC motors
AC-3e: Squirrel-cage motors with higher locked rotor current: starting, switching off motors during running, reversing	DC-5, Series motors: starting, plugging, inching, dynamic breaking of DC motors
AC-5a: Electric discharge lamps (ballast)	DC-12: Control of resistive loads and static loads with opto-coupler isolation
AC-5b: Incandescent lamps	DC-13: Control of DC electromagnets
AC-6a: Transformers	DC-PV3: Carrying full current and switching ON and OFF PV circuit(s) at low current
AC-6b: Capacitor bank switching	
AC-15: Control of electromagnetic loads (>72 VA)	
AC-14: Control of weak electromagnetic loads (≤ 72 VA)	

General use and heaters

The harmonized utilization category AC-1 covers general and resistive type loads. This includes non-inductive or slightly inductive loads, as well as resistance furnaces and heaters. Additional ratings, such as "Resistance Air Heating" and "CSA Electrical Heating Control", which require additional electrical cycling, can be performed to further validate control devices for use in heating applications. However, the general use of the AC-1 rating is sufficient for most heating applications.

Motors

Due to their high inrush peaks, locked rotor currents and high potential for overheating, motor loads represent one of the most demanding types of load. The figures below show an overview of an across-the-line motor start. Starting current is a characteristic of the motor. Starting time is a function of load torque, inertia and motor torque and is influenced by the motor technology. As the starting current ratio ($6-10 \times I_e$) is higher than the rated operational current I_e , an excessively long starting or breaking period can cause an overload (temperature rise) in the motor. This can create electromechanical stresses or damage the motor's insulation if it is not properly protected.

There are many different manufacturers on the market, selling at various prices. Not all motors have the same performance and quality as ABB motors. High efficiency enables significant savings in energy costs during the motors' normal endurance. In the standard for rotating electrical machines, IEC 60034-30, four different efficiency classes have been defined. The classes are called IE1, IE2, IE3 and IE4, where motors belonging to IE4 are the most efficient ones. See the graph below. A low level of noise is also a priority today, as well as the ability to withstand demanding environments. There are also other parameters that differ. The design of the rotor affects the starting current and torque and there can be very significant variation between different manufacturers for the same power rating.

Different diagrams with the different currents at the start of a motor

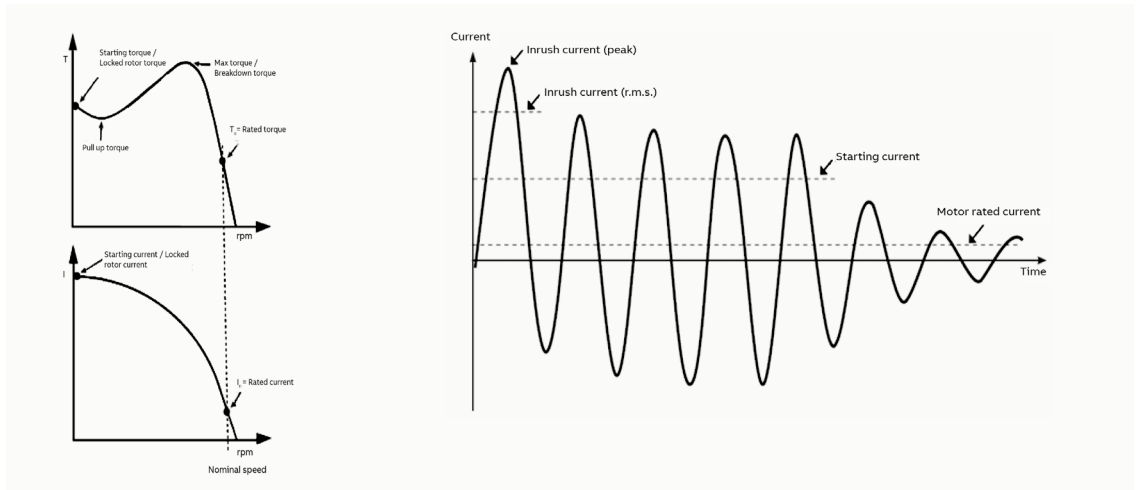

About motors

Modern electric motors are available in many different forms, such as single-phase motors, three-phase motors, brake motors, synchronous motors, asynchronous motors, special customized motors, two-speed motors, three-speed motors, and so on, all with their own performance and characteristics. For each type of motor, there are many different mounting arrangements, for example, foot mounting, flange mounting or combined foot and flange mounting.

The cooling method can also differ a great deal, from the simplest motor with free self-circulation of air to a more complex motor with totally enclosed air-water cooling with an interchangeable cassette type of cooler.

To ensure a long life for the motor, it is important to select it with the correct degree of protection when operating under heavy-duty conditions in a severe environment.

The letters IP (International Protection) state the degree of protection followed by two digits, the first of which indicates the degree of protection against contact and penetration of solid objects, whereas the second states the motor's degree of protection against water.

The end of the motor is defined in the IEC standard as follows:

- The D-end is normally the drive end of the motor
- The N-end is normally the non-drive end of the motor

Interior view of a motor with all components

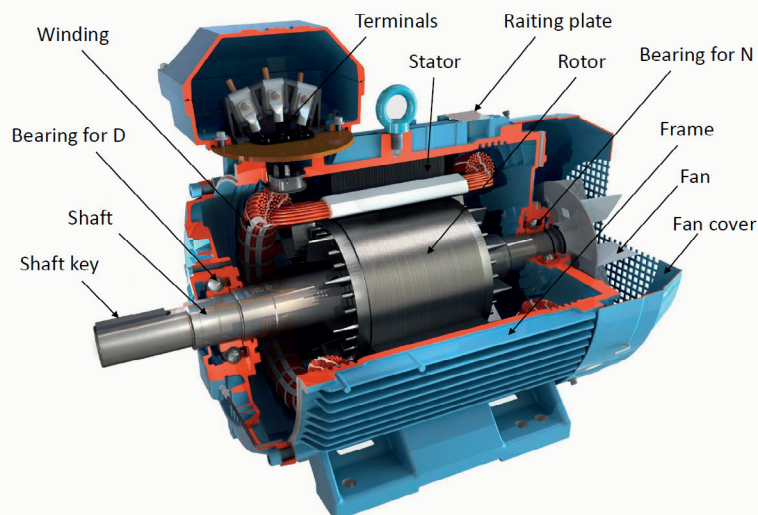

LOAD TYPES

Squirrel cage motors

The squirrel cage motor is the most common type on the market. It is relatively cheap and maintenance costs are usually low. There are many different manufacturers represented on the market, selling at various prices. Not all motors have the same performance and quality as motors from ABB.

The starting current of motors is a characteristic of the motor. The starting time is a function of load torque, inertia, and motor torque and is influenced by the motor technology. As the starting current ($6-8 \times I_e$) is always much higher than the rated operational current: an excessively long starting or braking period will cause an overload (temperature rise) in the motor. This could cause electromechanical stresses or damage the motor's isolation.

The lifetime of an electric motor is linked to temperature stress. As a rough guide, the lifetime of the winding isolation reduces by half each time the temperature exceeds 10 °C. Even slight temperature increases can decrease the lifetime of an electric motor significantly.

International motor efficiency standards and regulations

International motor efficiency standards and regulations

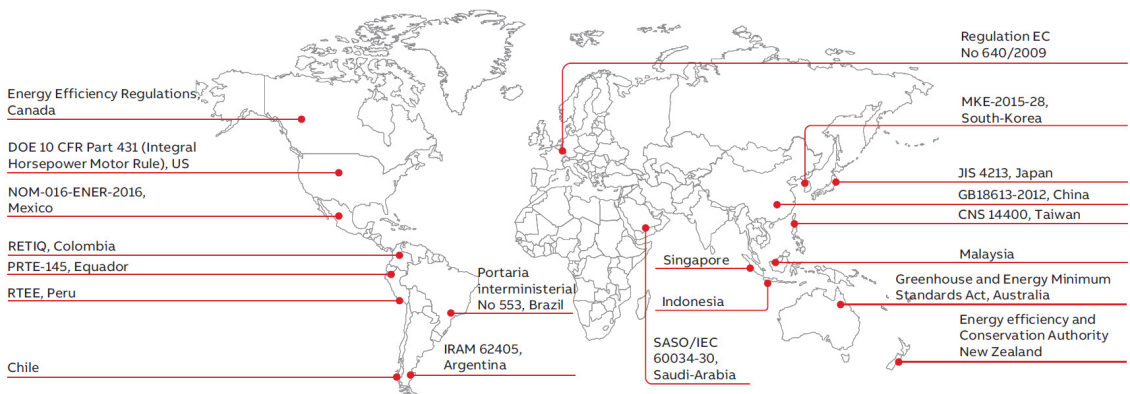

Since the validation of IEC 60034-30:2008 and its refined version IEC 60034-30-1:2014, a worldwide energy efficiency classification system has existed for low voltage three-phase asynchronous motors. These international standards have been created to enable and increase harmonization in efficiency regulations around the world and to also cover motors for explosive atmospheres.

IEC 60034-30-1:2014 defines International Efficiency (IE) classes for single-speed, three-phase, 50 Hz and 60 Hz induction motors. The efficiency levels defined in IEC 60034-30-1 are based on the test method specified in IEC 60034-2-1:2014. Both standards are part of an effort to unify motor testing procedures with CSA390-10 and IEEE 112 standards as well as efficiency and product labeling (IE) requirements to enable motor purchasers worldwide to easily recognize premium efficiency products.

To promote transparency in the market, IEC 60034-30-1 states that both the efficiency class and efficiency value must be shown on the motor rating plate and in product documentation. The documentation must clearly indicate the efficiency testing method used as different methods can produce differing results.

Minimum energy performance standards

While the IEC as an international standardization organization sets guidelines for motor testing and efficiency classes, the organization does not regulate efficiency levels in countries. The biggest drivers for mandatory Minimum Energy Performance Standard (MEPS) levels for electric motors are global climate change, government targets to curb CO₂ emissions and rising electricity demand, especially in developing countries. The whole value chain, from manufacturer to end user, must be aware of the legislation in order to meet local requirements, to save energy and reduce the carbon footprint.

Harmonized global standards and the increasing adoption of MEPS around the world are good news for all of us. However, it is important to remember that harmonization is an ongoing process. Even though MEPS are already in effect in several regions and countries, they are evolving and differ in terms of scope and requirements. At the same time, more countries are planning to adopt their own MEPS regulations. A view of existing and future MEPS regulations worldwide can be seen on the world map above.

Efficiency classes of line-operated AC motors IEC 60034-30-1

It is important to know which engine types are exempt from the new efficiency regulations. IEC 60034-30-1 defines four International Efficiency (IE) classes for single speed electric motors that are rated as designed for operation on sinusoidal voltage:

- IE4 = Super premium efficiency
- IE3 = Premium efficiency
- IE2 = High efficiency
- IE1 = Standard efficiency

Overview of the nominal efficiency limits defined in IEC 60034-30-1.
Note: A detailed overview of the nominal efficiency limits defined in IEC 60034-30-1 can be found in chapter 9. Appendix.

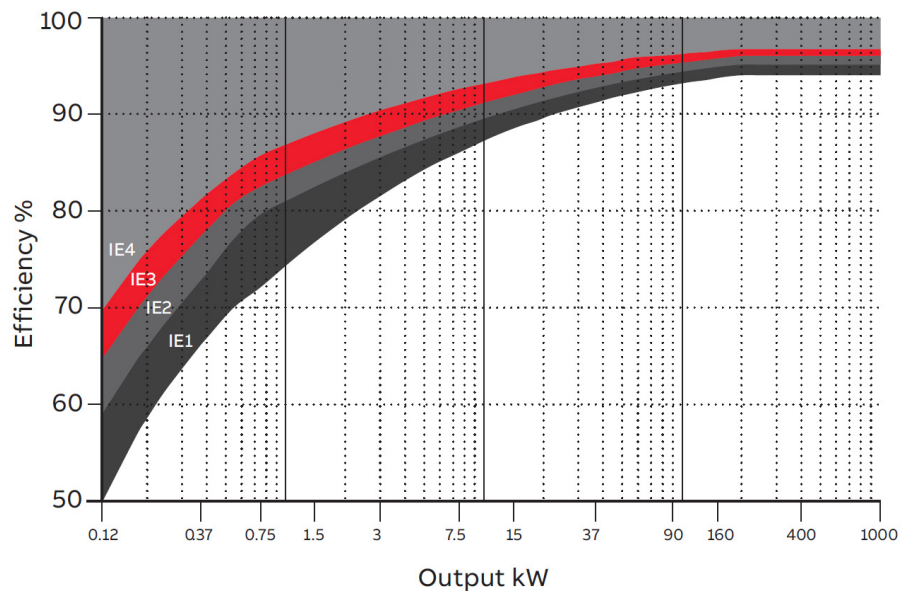

LOAD TYPES

IEC 60034-30-1 covers the power range from 0.12 kW up to 1000 kW. Most of the different technical constructions of electric motors are covered if they are rated for direct-on-line operation. The coverage of the standard includes the recommendation and exclusions below:

IE3/IE4 motor requirements and recommendation	IE3/IE4 motor exclusion
<ul style="list-style-type: none"> • Voltage range for low voltage motors up to 1000 V • Mains frequency of 50 and 60 Hz • Number of poles: 2, 4, 6, 8 • Degree of protection: all • Operating mode: S1 (continuous load), as well as electric motors designed for other operating modes, but which can still be operated continuously at rated power – Motors with two switchable rated voltages (as long as the magnetic flux is the same at both voltages) • Temperature range: -20 °C to +60 °C • Installation altitude: up to 4,000 m above sea level 	<ul style="list-style-type: none"> • Motors for one speed with 10 or more poles, as well as motors designed for several speeds • Motors with mechanical commutators (e.g. DC motors) • Motors that are fully integrated into a machine and cannot be tested independently • Motors with integrated frequency inverters (compact drives) • Submersible motors that are especially designed to be operated completely immersed in liquids • Explosion-proof motors and brake motors

Note: Additional exclusions are also provided by the European MEPS (EC 640/2009).

What distinguishes an IE3/IE4 motor from less efficient motors?

IE3/IE4 motors can achieve higher efficiency thanks to innovative design and the use of better conducting material. The higher efficiency design ultimately shows a lower rated motor current for any given kW rating. However, during the motor’s starting phase, there may be an increase in inrush and starting current. The increased inrush and starting current can in some cases affect the selection of the starter components as well as the short-circuit protection device.

If a motor is directly connected to the power line, the current drawn (which is mostly reactive) will be very high during start-up. The curve in the following graph shows a typical starting RMS current curve for an IE3/IE4 motor in a direct-on-line connection. In general, the motor draws current in three steps:

- After starting, during the first 10 msec to 15 msec: 'I_{peak}', an inrush current with a very high peak current. This high peak current is much higher than for IE1/IE2 motors. This is a result of the higher locked rotor apparent power and the locked rotor current reaching the higher efficiency class according to IEC 60034-30-1.
- Between the inrush and 0.5 s to 10 s, the important step starts (depending on rated power and inertia), there is a locked rotor current 'I_{lrc}'. This current remains constant as long as the rotor starts revolving. Its duration depends on the motor’s load and design.
- Typically, after 0.5 s to 10 s, the rotor reaches its final speed. The current stabilizes to reach the motor’s rated current 'I_n' at full load.

Diagram with the current at the start-up of an IE3/IE4 motor

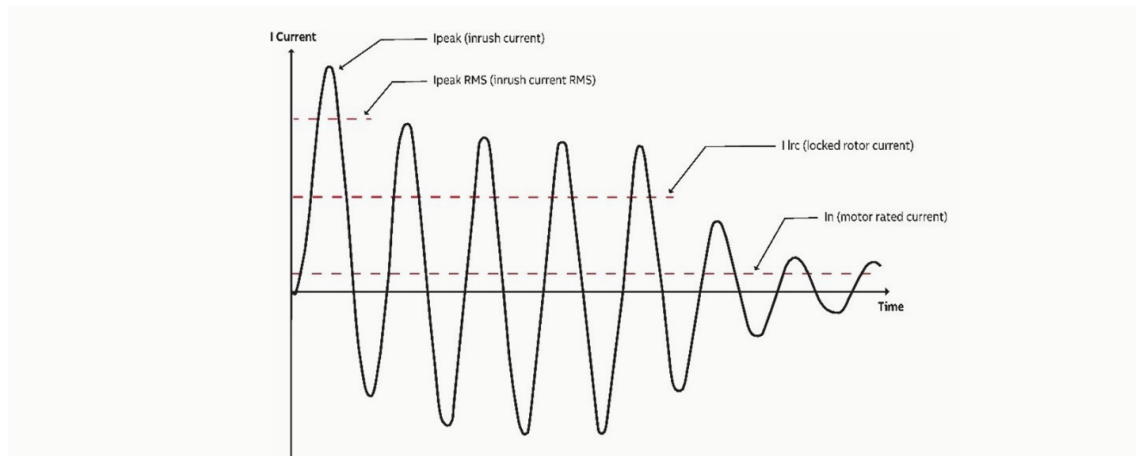

The tests and analyses clearly show that high-efficiency motors IE3/IE4 NE/HE, may in general draw a higher starting current than IE3/IE4 N/H motors. Once the IE3/IE4 motor reaches full speed, the rated motor current is lower compared to IE2 motors for the same load conditions, because of its higher efficiency (therefore saving more energy).

Diagram with the current at the start-up of a IE3 motor

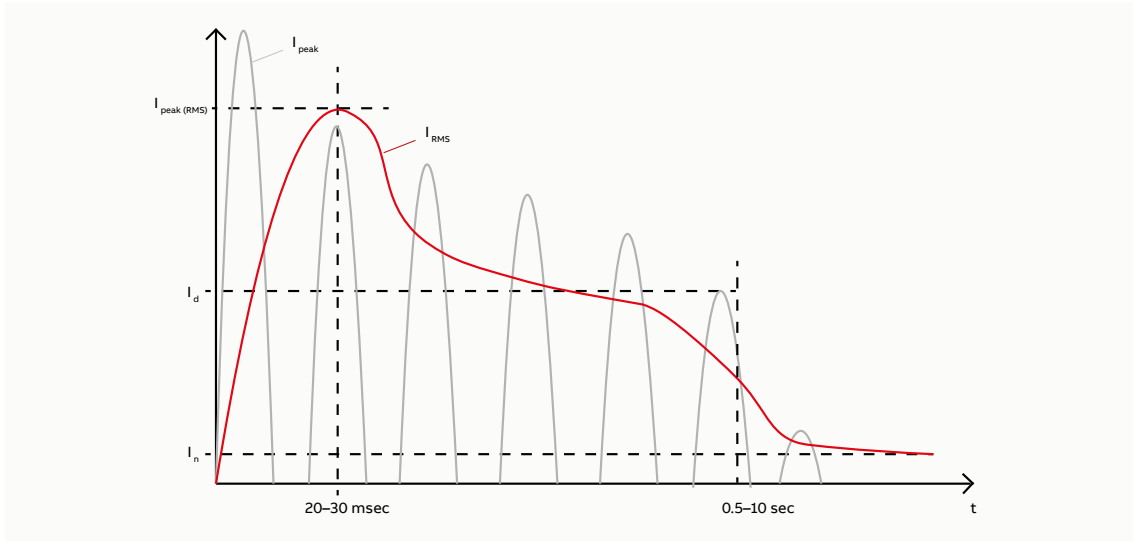

The tests and analyses clearly show that high-efficiency motors IE3/IE4 NE/HE, in general, may draw a higher starting current than IE3/IE4 N/H motors. Once the IE3/IE4 motor reaches full speed, the rated motor current is lower compared to IE2 motors for the same load conditions, because of its higher efficiency (therefore saving more energy).

Diagram with the difference in current for IE3/IE2 motors

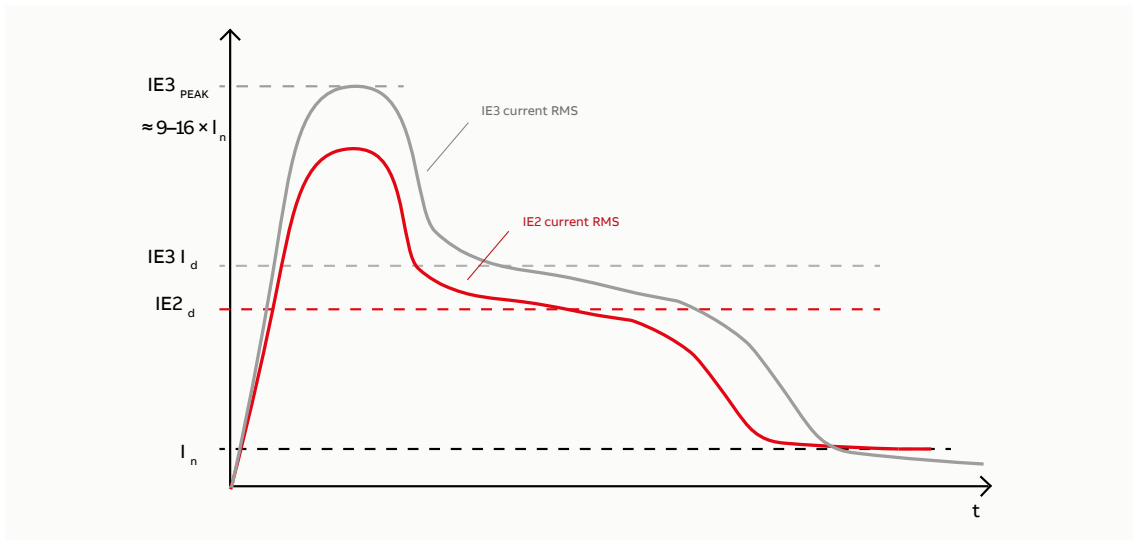

LOAD TYPES

Rating plate of a motor

The rating plate details on a motor provide the user with information relating to the motor's construction and performance characteristics. On the rating plate, it is necessary to indicate the IE code and nominal efficiency of the motor at full load 100%, 3/4 load 75% and 1/2 load 50%, as required by IEC 60034-30-1. Here is an example of a rating plate:

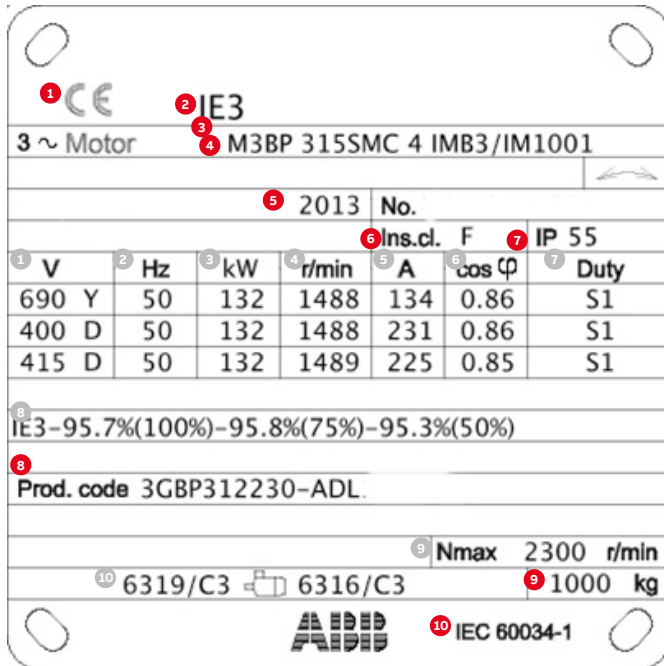

Basic information

- 1 Certification label
- 2 Efficiency Code – IE
- 3 Number of phases
- 4 ABB motor type
- 5 Manufacturing date
- 6 Insulation class
- 7 Degree of protection
- 8 Product code
- 9 Motor weight
- 10 IEC Standard

In-/output information

- 1 Rated operating voltage
- 2 Frequency
- 3 Motor rated power
- 4 Full load speed
- 5 Rated operating current
- 6 Power factor
- 7 Service factor
- 8 Partial load efficiencies
- 9 Rotation speed
- 10 Drive end bearing type and amount of grease (where applicable) and non-drive end bearing type and amount of grease (where applicable)

Voltage

Three-phase single speed motors can normally be connected for two different voltage levels. The three stator windings are connected in star (Y) or delta (D). If the rating plate on a squirrel cage motor indicates voltages for both the star and delta connection, it is possible to use the motor for both 230 V AC, and 400 V AC, for example.

The winding is delta connected at 230 V AC and if the main voltage is 400 V AC the star connection is used. When changing the main voltage, it is important to remember that for the same power rating the rated motor current will change depending on the voltage level. The method for connecting the motor to the terminal blocks for star or delta connection is shown in the picture below.

Voltage connection at the motor

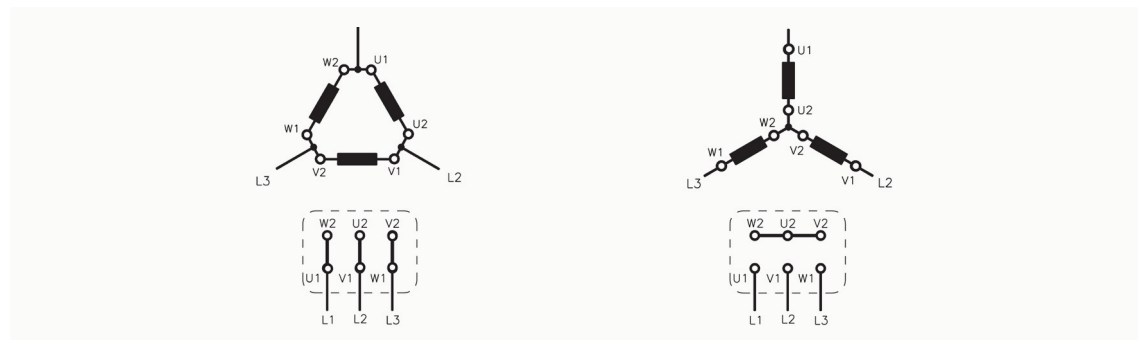

Current

The rated current of the motor, which can be found on the motor nameplate, is the current used by the motor when fully loaded and while up at full speed. An unloaded motor will use far less current and an overloaded motor will use more current. During direct-on-line start, the current used by the motor is far higher than the rated current though.

Usually between six to eight times the rated current (for IE2 motors), but it can be more than 10 times the rated current. This can be clearly seen in a speed-current diagram for the motor. As the motor accelerates, the current will drop and when reaching the rated speed, the current will have dropped to the rated current.

Diagram of the current vs. speed

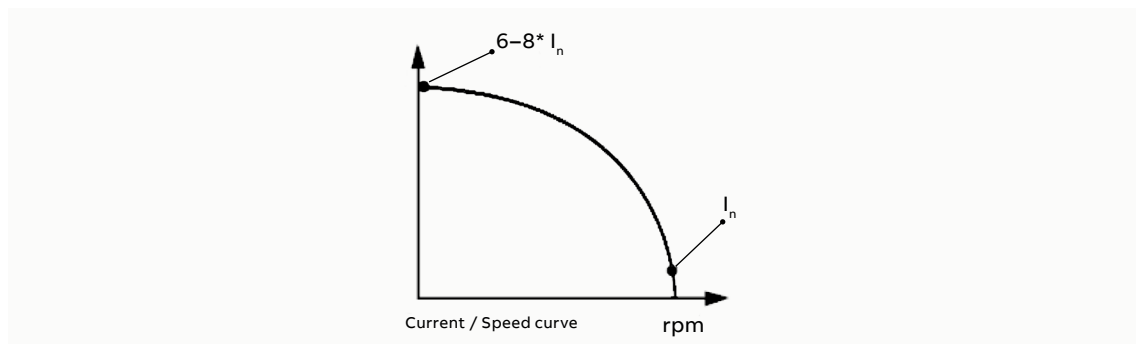

The required increase in efficiency of IE3 motors is usually achieved by lower-rated currents of the motors. In the small power ranges, the required increase in efficiency is greater, so that the deviation of the rated current is greater there. The higher the power, the lower the deviation of the rated currents compared to IE1 / IE2 motors.

Increasing starting current conditions

The starting current conditions (ratio of starting current to rated current, steady state, stalled rotor) increase with increasing IE class.

Amplitude of inrush current

The amplitude of inrush current from IE1 to IE2 and IE3 / IE4 depends on the following factors in the respective application:

- Structure of the motor
- Network conditions (in particular the size of the short-circuit power of the transformer and thus the voltage stability)
- Length and routing of motor cables
- Switch-on phase position in the respective phase.

Power factor

A motor always consumes active power, which it converts into mechanical action. Reactive power is also required for the magnetization of the motor, but it does not perform any action. In the diagram below the active and reactive power is represented by P and Q, which together give the apparent power S.

The ratio between the active power P (kW) and the apparent power S (kVA) is known as the power factor and is often designated as $\cos \phi$. A normal value is between 0.7 and 0.9. When running, where the lower value is for small or low loaded motors and the higher for large ones.

LOAD TYPES

Diagram indicating P, Q, S and cos φ

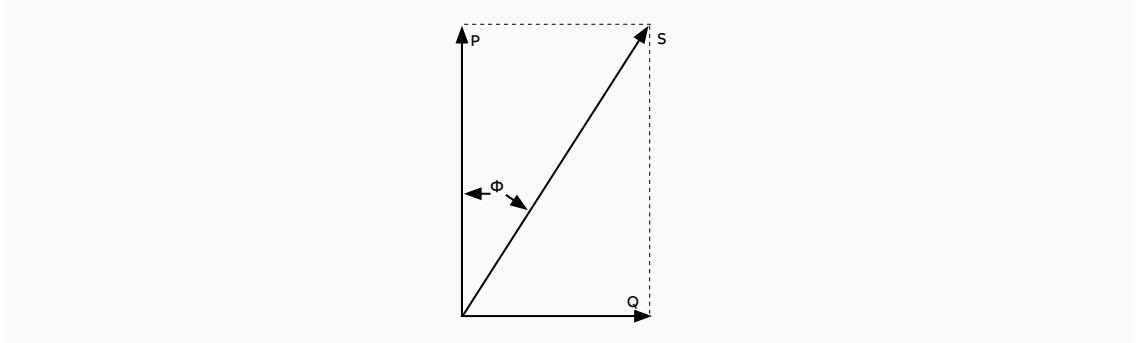

Torque

The starting torque for a motor differs significantly depending on the size of the motor. A small motor, e.g. ≤ 30 kW, normally has a value of between 1.5 and 2.5 times the rated torque, and for a medium-size motor, for example, up to 250 kW, a typical value is between two to three times the rated torque. Very large motors tend to have a very low starting torque, sometimes even lower than the rated torque. It is not possible to start such a motor fully loaded, not even through direct online starting.

- T_n = Rated torque (Nm)
- P_r = Rated motor power (kW)
- n_r = Rated motor speed (rpm)

Diagram of torque vs. speed

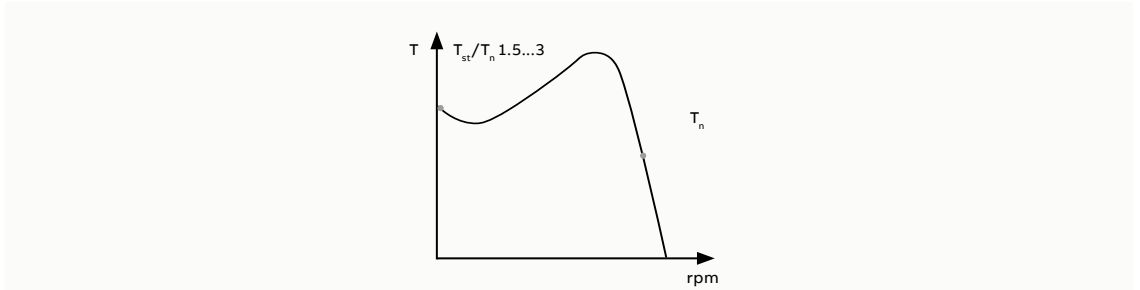

Different load conditions

All motors are used for starting and running different applications. These different applications will result in different load conditions for the motor. This is a direct braking force on the motor shaft. To be able to accelerate, the motor must be stronger than the load. The accelerating torque is the difference between the available motor torque and the load torque. Many starting methods will reduce the torque of the motor, thereby reducing the accelerating torque which will give a longer starting time. Accelerating torque = available motor torque – braking load torque. The load curve can have different characteristics depending on the application. Some of the common load types can be seen below.

Diagram of the torque vs. speed by different load conditions

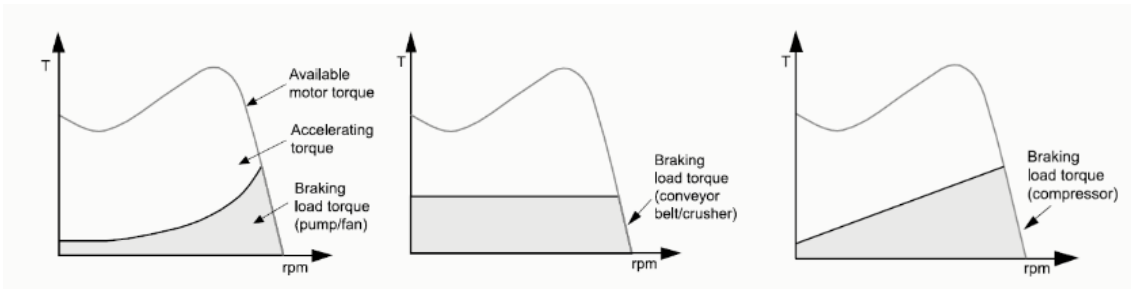

Many applications are usually started unloaded, and the load is applied first when the motor has reached the rated speed. This will reduce the load torque to about 10 to 50% of the load torque of a loaded start.

Contactors are well suited for both the control motors, including high-efficiency types. Since the tests for IEC utilization category AC-3 and UL/CSA "AC Motor" have yet to be fully harmonized, contactors carry both ratings to ensure international acceptability.

For additional information regarding IE3 high-efficiency motors for Europe, please click the "Info on IE3 Motors" link in the Selected Optimized Coordination (SOC) selection tool (<http://applications.it.abb.com/SOC/page/selection.aspx>).

Hermetic refrigerant compressor motors

A hermetic refrigerant compressor motor is a combination of a compressor and a motor, both of which are enclosed in the same housing, with no external shaft or shaft seals, with the motor operating in refrigerant. These motors are commonly used in air-conditioning and refrigeration equipment. Two harmonized utilization categories exist for these types of loads: AC-8a and AC-8b. AC-8b is an additional test accompanying AC-8a and is referred to as a "recycle rating", which covers applications where overload releases are automatically reset. For control AF contactors can be used.

DC switching applications

DC-1, DC-3, DC-5, DC-PV3 applications according to IEC 60947-4-1

The circuit switching on DC is more difficult than on AC, as alternating current goes to zero according to the frequency of the supply source while DC current has a continuous value.

General

The arc switching on DC is more difficult than on AC, due to no zero-crossing.

- It is essential to determine the current, the voltage and the L/R time constant of the controlled load.
- For information, typical time constant values are quoted hereafter: non-inductive loads such as resistance furnaces ($L/R \approx 1$ msec), inductive loads such as shunt motors ($L/R \approx 2$ msec) or series motors ($L/R \approx 7.5$ msec).
- The addition of a resistor in parallel with an inductive winding helps in the elimination of the arcs.

Time constant and utilization categories

In DC applications, the nature of load to switch (resistor, inductance or a combination) is characterized by the ratio of the inductance to the resistance (L (inductance of operated circuit) / R (resistance of operated circuit) = $mH/\Omega =$ msec). This ratio L/R is called the time constant of the circuit.

DC current utilization categories are defined according to IEC 60947-4-1:

- DC-1 non-inductive or slightly inductive loads, resistance furnaces ($L/R \leq 1$ msec)
- DC-3 shunt motors: starting, plugging, inching, dynamic breaking of DC motors ($L/R \leq 2$ msec)
- DC-5 series motors: starting, plugging, inching, dynamic breaking of DC motors ($L/R \leq 7.5$ msec)

The higher the time constant value is, the more difficult it is to break the arc. The addition of a resistor in parallel with an inductive winding helps in the elimination of the arcs by reducing the time constant.

Operational voltage

- The higher the operating voltage value is, the more difficult it is to break the arc
- The use of main poles connected in series will allow to increase the value of switched voltage

However, the maximum switched voltage must be within the maximum operational voltage of the contactor. All the poles required for breaking must be connected in series between the load and the source polarity not linked to the earth (or chassis) (see recommended connection diagrams).

LOAD TYPES

Connection diagrams

Recommended connection

In the example below, the three poles are connected in series without the load in between. This connection is recommended in systems according to the following configurations.

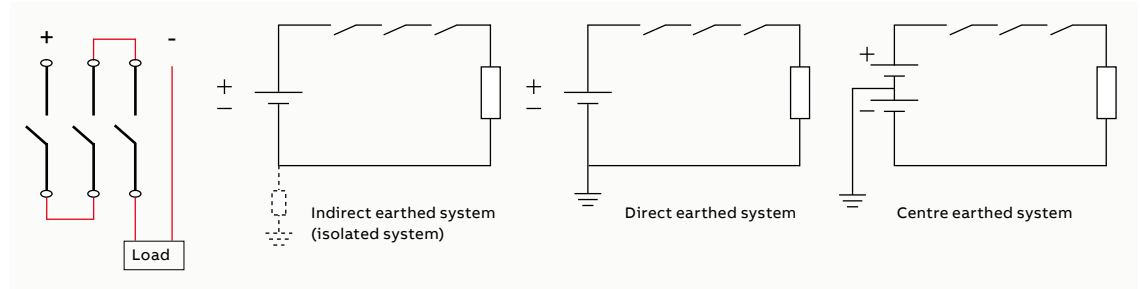

Alternative connection (not possible for GA75, GAE75)

The load could be placed in between the contacts in an indirect earthed system. If not connected according to the configuration below, a fault to earth could result in one or two contacts breaking the full load for which the contactor is not approved.

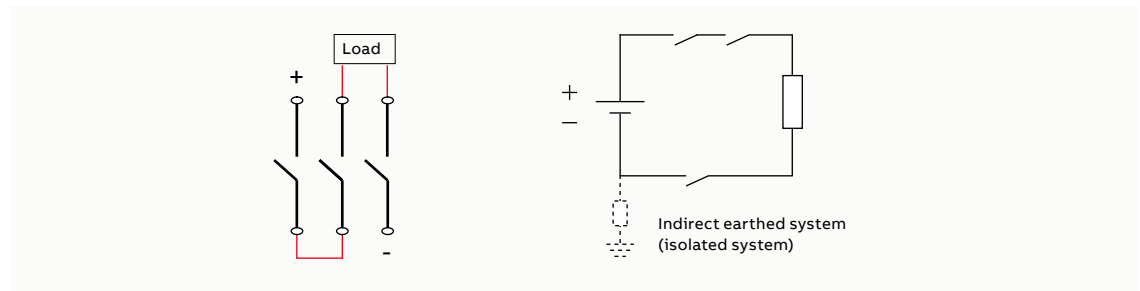

Note: The above relates to power circuit switching. The SCPD (Short Circuit Protection Device) must comply with the applicable protection rules.

Lamps and lighting loads

Two lamp-specific utilization categories exist AC-5a for electric discharge (fluorescent) lamps, and AC-5b for incandescent lamps, both of which have been fully harmonized. The AF contactors are suitable for the manual control of lamp loads. The table below shows a correlation between these ratings and a variety of commercially available lamps.

Lamp type	Ballast AC-5a	Tungsten AC-5b
Compact fluorescent lamps	●	
Fluorescent lamps with electronic ballast ¹⁾	●	
Halogen electric light bulbs		●
Halogen metal vapor lamps	●	
High-pressure discharge lamps	●	
Incandescent (filament) light bulbs		●
LEDs	●	
Mercury vapor high-pressure lamps	●	
Mixed lamps		●
Sodium vapor high-pressure lamps	●	

Lighting circuits

In a given circuit, the number and power rating of lamps are defined and cannot result in overload. Only short-circuit protection needs to be provided. gG fuses or modular circuit-breakers will be chosen for this purpose. The lamps have very specific technical data, according to their construction type.

- Incandescent lamps have a very high current on closing: more than 15 times nominal current. They do not introduce a large phase displacement between current and voltage.
- Fluorescent tubes are equipped with a ballast whose purpose is two-fold: contribute to ignition and limit current to nominal value once a steady state is reached. This ballast is a reactor that considerably lowers the power factor. It may or may not be compensated.

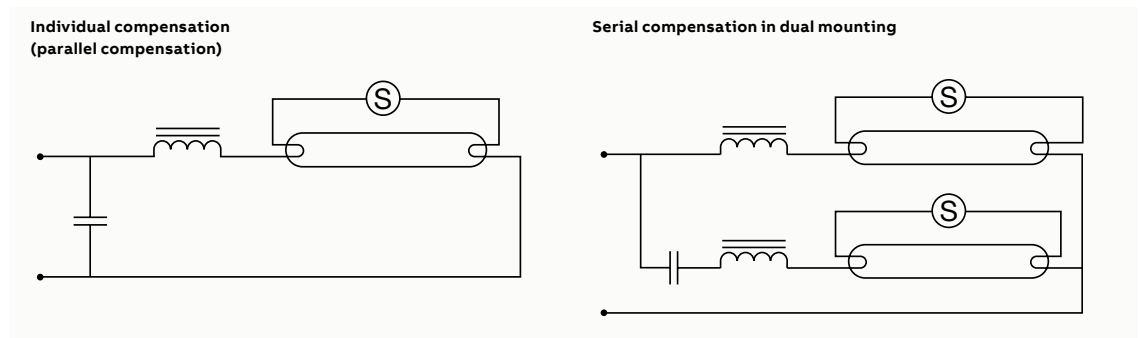

Capacitors

AC-6b utilization category according to IEC 60947-4-1

In Low Voltage industrial installations, capacitors are mainly used for reactive energy correction (raising the power factor). When these capacitors are energized, overcurrents of high amplitude and high frequencies (3 to 15 kHz) occur during the transient period (1 to 2 msec).

The amplitude of these current peaks, also known as "inrush current peaks", depends on the following factors:

- The network inductances
- The transformer power and short-circuit voltage
- The type of power factor correction

Types of power factor correction

There are two types of power factor correction: fixed or automatic.

• Fixed power factor correction

Fixed power factor correction consists of inserting, in parallel on the network, a capacitor bank whose total power is provided by the assembly of capacitors of identical or different ratings. The bank is energized by a contactor that simultaneously supplies all the capacitors (a single step). The inrush current peak, in the case of fixed correction, can reach 30 times the nominal current of the capacitor bank.

• Automatic power factor correction

An automatic power factor correction system, on the other hand, consists of several capacitor banks of identical or different ratings (several steps), energized separately according to the value of the power factor to be corrected.

An electronic device automatically determines the power of the steps to be energized and activates the relevant contactors. The inrush current peak, in the case of automatic correction, depends on the power of the steps already on duty and can reach 100 times the nominal current of the step to be energized.

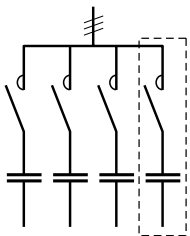

Multi-step capacitor bank scheme *line break*
Use the UA... or UA...
RA contactor ranges.

LOAD TYPES

Steady state condition data

The presence of harmonics and the network's voltage tolerance lead to a current, estimated to be 1.3 times the nominal current I_n of the capacitor, permanently circulating in the circuit. Taking into account the manufacturing tolerances, the exact power of a capacitor can reach 1.15 times its nominal power.

Standard IEC 60831-1 Edition 2002 specifies that the capacitor must, therefore, have a maximum thermal current I_T of:

$$I_T = 1.3 \times 1.15 \times I_n = 1.5 \times I_n$$

The consequences for the contactors: to avoid malfunctions (welding of main poles, abnormal temperature rise, etc.), contactors for capacitor bank switching must be sized to withstand:

- A permanent current that can reach 1.5 times the nominal current of the capacitor bank
- The short but high peak current on pole closing (maximum permissible peak current \hat{I})

Overview of load types for contactors

Switching type		Applicable device for the application
Motor	AC-3 / AC-3e: Squirrel-cage motors	AF09 ... AF1650 3-phase contactors are mainly used for controlling motors from 4 up to 560 kW.
Resistive loads	AC-1: General use	AF09 ... AF2850 3-phase contactors are also used for controlling power circuits from 25 up to 2850 A. AF09 ... AF370 4-pole contactors are mainly used for controlling non-inductive or slightly inductive loads (i.e. resistance furnaces...) and generally for controlling power circuits from 25 up to 525 A.
Direct current (DC)	DC-1, L/R ≤ 1 msec DC-3, L/R ≤ 2 msec DC-5, L/R ≤ 7.5 msec	AF09 ... AF2850 3-pole or AF09 ... AF370 4-pole contactors with either 1-pole breaking or breaking with poles connected in series. Special contactors designed for DC breaking with permanent magnets fitted on the main poles for use with the 3 poles connected in series and considered as 1-pole devices: GA75 and GAE75 contactors: the 3 poles are connected in series via two supplied and fitted insulated connections, for current up to 100 A DC-1. GAF145 ... GAF2050 contactors: the 3 poles must be connected in series by the user according to conductor cross-sectional area (refer to main pole technical data) or by using LP connection bars (to be ordered separately) for current up to 100 A DC-1. GF875...GF1050 contactor for 1500 VDC switching, DC-1, and DC-PV3 (although not DC-3). GF has no permanent magnet installed, so it is bi-directional.
Capacitor	AC-6b: Capacitor bank	Contactors versions according to the value of the inrush current peak and the power of the capacitor banks: UA..RA contactors for capacitor switching (UA16..RA to UA110..RA) with insertion of damping resistors for 12.5 up to 80 kvar. The insertion of damping resistors protects the contactor and the capacitor from the highest inrush currents. UA contactors for capacitor switching (UA16 to UA110) for 12.5 up to 75 kvar. Maximum permissible peak current $\hat{I} \leq 100$ times the nominal rms current of the switched capacitor.
Lighting circuit	AC-5a / AC-5b	AF09 ... AF2650 3-pole or AF09 ... AF370 4-pole contactors are also used for controlling a light load.
Auxiliary and control circuits	AC-15/ AC-14/ DC-12 / DC-13	NF22 ... NF80 4-pole and 8-pole contactor relays CA4, CC4, CAT4, CAL Auxiliary contact blocks

NOTES

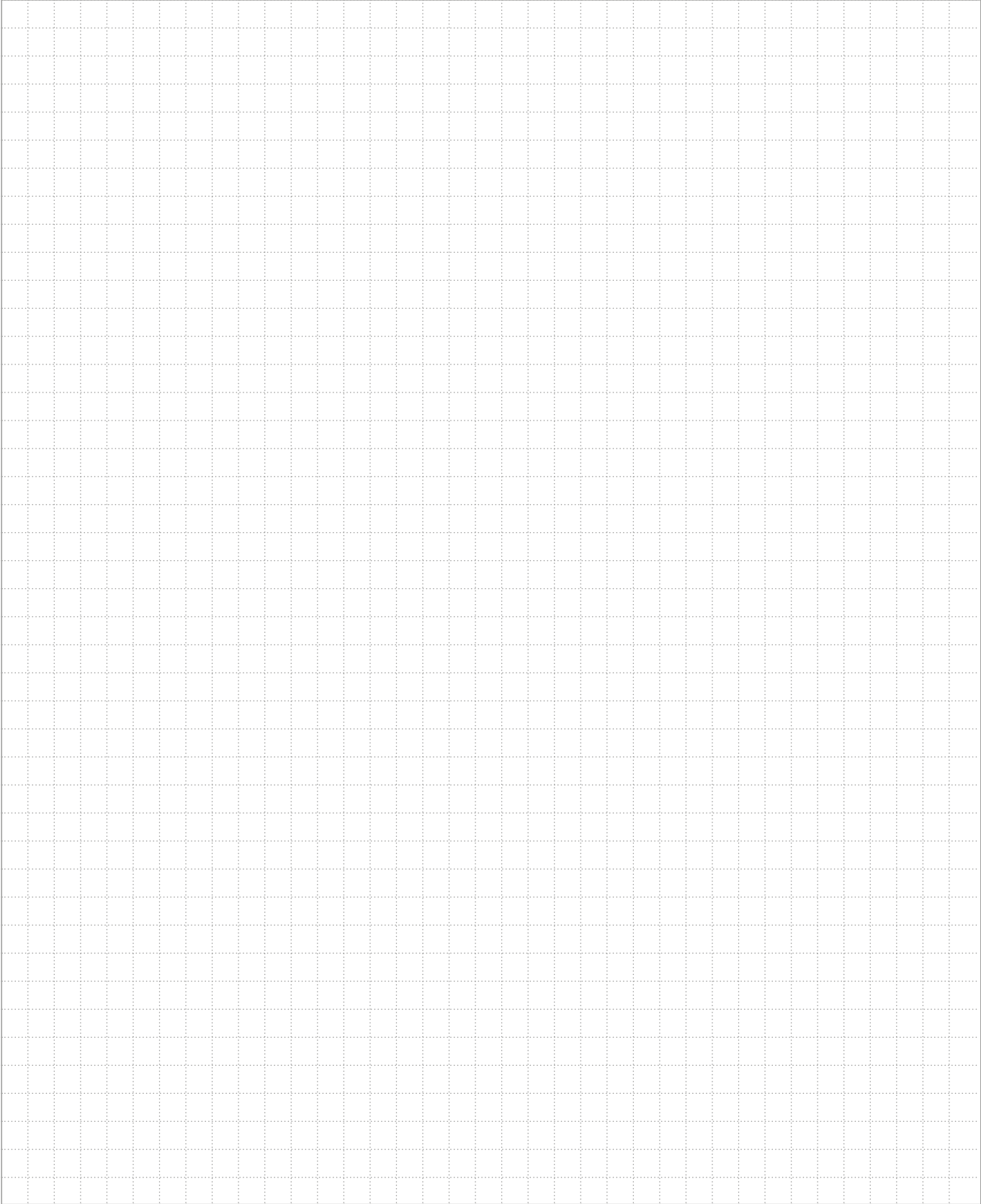

04

SELECTION CRITERIA

- 4/2 Sizing contactor for motor applications**
- 4/2 Selected Optimized Coordination (SOC)**

SELECTION CRITERIA

Sizing contactor for motor applications

Contactors should be sized based on the rated current (for UL full-load current (FLC)) of the motor. The rated operational current I_e of the contactor represents the maximum current rating of the device. Contactors should be selected so that the motor current rating falls between these ranges.

Selected Optimized Coordination (SOC)

To help in selecting the right ABB product for the application, the "Selected Optimized Coordination" (SOC) web tool is very useful. In order to guarantee the best performance and the longest lifetime, devices involved in the applications mentioned above (short-circuit protection devices, contactors, overload relays, softstarters ...) need to be coordinated.

The coordination among devices cannot be determined directly: tests in power laboratories have to be carried out to qualify the coordination type at low fault and high fault currents, according to IEC or UL standards. ABB coordination tables are the results of such tests and represent the ABB offerings in terms of motor starting and protection, selectivity, backup and switch-disconnector protection.

In SOC, all available ABB coordination tables are stored and easily accessible. The following chapter is a guide to the main tasks and user interactions.

SOC is available on www.abb.com/lowvoltage (in the "Support " menu select "Online Product Selection Tools ", then select "Coordination Tables") or click on the following permanent link: <http://applications.it.abb.com/SOC>

Screenshot from SOC

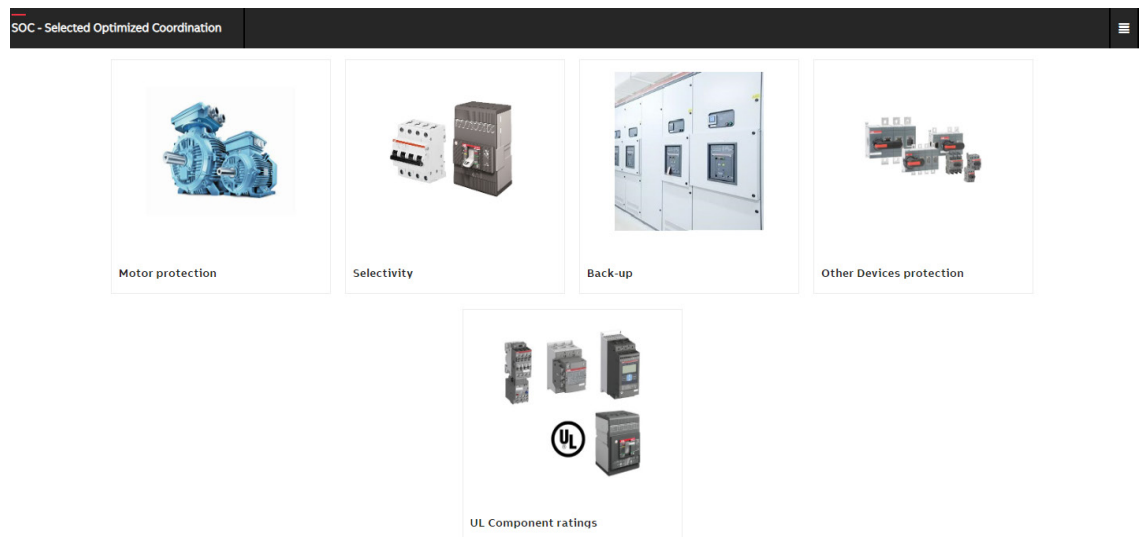

Under the interface "Motor protection" the following filters are available:

- type of protection device
- rated voltage
- short-circuit current
- starter type
- coordination type
- overload relay
- motor rated power

Example: if you are looking for products for motor protection, where a manual motor starter is used as short-circuit protection device, in a plant where the rated voltage is 400 V AC and the IE3 Motor Rated Power is 2.2 kW:

Screenshot from an example on SOC

SOC - Selected Optimized Coordination

Standard: IEC UL CMC

Starting type: Normal start Heavy duty

Motor Efficiency Class - Design: Any IE1/IE2/IE3/IE4 - N/H IE3/IE4 - NE/HE

Table status: Any Active Legacy

Starter Type	Rated voltage	Motor rated power	Rated short-circuit current	Coordination type	Protection device	Overload protection
Direct-on-line starter	230 V AC	0.06 kW	12 kA	IEC Type 1	Air circuit-breaker	Embedded
Star-Delta starter	400 V AC	0.09 kW	16 kA	IEC Type 2	Switch fuse	Thermal overload relay
Soft starter (In Line)	415 V AC	0.12 kW	20 kA		Molded case circuit-breaker	Electronic overload relay
Soft starter (Inside Delta)	440 V AC	0.18 kW	25 kA		Manual motor starter	Universal motor controller
Drive starter	480 V AC	0.25 kW	30 kA			Smart-Current/Voltage Sensor
	500 V AC	0.37 kW	35 kA			

683 Coordination tables found

Export PDF PDF Books Reset filters

SOC is showing the right protection device for the selected application depending on the coordination type. Click on >> to see the complete table.

Screenshot from an example on SOC

27 Manual motor starter, 400 V AC, 50 kA, Direct-on-line starter, Coordination type: IEC Type 2, Overload protection: Embedded, Motor Efficiency Class - Design: IE1/IE2/IE3/IE4 N/H, (MS405NS2MS16AS.01)

Motor	Protection device	Contactor	Overload protection	Table				
Motor rated power	Rated Current (Ie)	Type	Inst.Trip.Current	Current range	Type	Max allowed load current	Status	ID
0.06 kW	0.2 A	MS118-0.25	3.13 A	0.16 - 0.25 A	AF09-AP	Embedded	0.25 A	Active (1766) >>

28 Manual motor starter, 400 V AC, 50 kA, Direct-on-line starter, Coordination type: IEC Type 2, Overload protection: Embedded, Motor Efficiency Class - Design: IE1/IE2/IE3/IE4 N/H, (MS132-MS165-MSS100-IE3)

Motor	Protection device	Contactor	Overload protection	Table				
Motor rated power	Rated Current (Ie)	Type	Inst.Trip.Current	Current range	Type	Max allowed load current	Status	ID
0.06 kW	0.2 A	MS132-0.25	3.13 A	0.16 - 0.25 A	AF09	Embedded	0.25 A	Active (2791) >>



05



INSTALLATION AND DE-INSTALLATION

- 5/2 Temperature**
- 5/3 Recommendation in use in applications**
- 5/3 Recommendation for storage**
- 5/6 Electrical durability**
- 5/12 Pollution degree**
- 5/12 Modality of storage**
- 5/12 Putting into service**

INSTALLATION AND DE-INSTALLATION

Contactors are suitable for use in many climates. They are intended for use in enclosed environments in which no severe operating conditions (such as dust, caustic vapors or hazardous gases) prevail. When installed in dusty and damp areas, suitable enclosures must be provided.

Temperature

Temperature rise limits of parts of contactors

ABB tests the contactors according to Standard IEC 60947-1 table 2 and 3. The heating of the contactor is a result not only of the surrounding ambient temperature but also of the connected load, which must be added to the surrounding temperature. The temperature of the contactor can be influenced by ventilation and cooling so that the temperature can be reduced by heat removal. If heat removal is insufficient, the resistance of the contact will increase as the material heats up. The increased resistance of the contact and also of the installation contactor increases the temperature. This table indicates the maximum temperature rise of the contactor. Here you will find some examples for the temperature rise.

Table from the IEC 60947-1 Temperature-rise limits of terminals

Terminal material	Temperature-rise limits ^{a,c} in kelvin [K]
Bare copper	60
Bare brass	65
Tin-plated copper or brass	65
Silver-plated or nickel-plated copper or brass	70
Other metals	b

The use in service of connected conductors significantly smaller than those listed in Tables 9 and 10 could result in higher terminals and internal part temperatures and such conductors should not be used without the manufacturer's consent, since higher temperatures could lead to equipment failure.

- b Temperature-rise limits to be based on service experience or life tests but not to exceed 65 K.
 c Different values may be prescribed by product standards for different test conditions and for devices of small dimensions, but not exceeding the values of this table by more than 10 K.

Table from the IEC 60947-1 Temperature-rise limits of accessible parts

Accessible parts	Temperature-rise limits ^a in kelvin [K]	
Manual operating means:	Metallic	15
	Non-metallic	20
Parts intended to be touched but not hand-held:	Metallic	30
	Non-metallic	40
Parts which need not be touched during normal operation b:	Exteriors of enclosures adjacent to cable entries:	
	Metallic	40
	Non-metallic	50
	Exterior of enclosures for resistors	200b
	Air issuing from ventilation openings of enclosures for resistors	200b

Different values may be prescribed by product standards for different test conditions and for devices of small dimensions but not exceeding by more than 10 K the values of this table.

- b The equipment shall be protected against contact with combustible materials or accidental contact with personnel. The limit of 200 K may be exceeded if so stated by the manufacturer. Guarding and location to prevent danger is the responsibility of the installer. The manufacturer will provide appropriate information, in accordance with section 5.3.

Recommendations for use in applications

Ambient air temperature

The contactors are intended for use in an ambient air temperature (ambient air temperature is the temperature near the device) inside the following temperature range:

For AF09 ... AF96:

- Close to Contactor without Thermal O/L Relay -40 ... +70 °C
- Close to Contactor Fitted with Thermal O/L Relay -25 ... +60 °C

For AF116 ... AF2860:

- Close to Contactor without Thermal O/L Relay -40 ... +70 °C
- Close to Contactor Fitted with Thermal O/L Relay -25 ... +50 °C

Climatic withstand

The AF contactors are tested according to the Standard IEC 60947-1 Annex Q, and reached the category B: Environment subject to temperature and humidity (temperature test range -25 °C to +70 °C) = MC1+CC2+SC1, means:

- MC1: no vibration;
- CC2: -25 °C to +70 °C (second range: dry heat test at +70 °C / damp heat test at +55 °C / cold test at -25 °C); and
- SC1: no salt mist.

Shock and vibration stress

The AF contactors are tested with regard to their shock resistance to sinusoidal and rectangular shock

Recommendation for storage

General cautions at products arrival in storage areas

Check contactors, thermal and electronic overload relays on receipt,

Cover packages of the equipment with a waterproof sheet.

Ambient air temperature and humidity

Equipment is intended to be stored at ambient air temperature (*) inside the following temperature range: Close to contactor for storage -60 ... +80 °C

The relative humidity of the air must not exceed 50% at a temperature of +40 °C. Higher relative humidity is permitted at lower temperatures (e.g. 90% at +20 °C); for higher temperature lower relative humidity is permitted (e.g. 20% at 70 °C).

Equipment is intended to be stored inside a stable temperature environment:

Quick or low temperature variation can create condensation inside the products and damage them. (e.g. PCB soldering and connection)

Fast changes of temperature must be avoided: in case equipment are subjected to fast changes of temperature, it is mandatory to check that there is no condensation on the contactors or the thermal and electronic overload relays before putting into service.

(*) Ambient air temperature is the temperature near the device.

Precipitation and wind

Equipment has to be stored in a covered room or warehouse as it is important to protect it from rain, hail, snow, wind and the combined action of precipitation and wind.

Additional protection could be considered to cover the packages of equipment with a waterproof sheet on the upper, lower and lateral surfaces of the packages themselves with regard to room or warehouse environments.

INSTALLATION AND DE-INSTALLATION

Air pressure

Solar radiation

Equipment has to be stored inside a room or warehouse as it is important to protect it from direct solar radiation: exposure to solar radiation causes temperature peak that can damage plastic materials and grease. If the air temperature is often near to the lower limit allowed (-40 °C) it is mandatory to keep the equipment inside a room because the radiation from the contactors and thermal and electronic overload relays to the sky can further reduce the temperature in many parts, accelerating the aging phenomena.

Dust, sand and smoke

Dust, sand and smoke cause damage and rapid wear of products; these effects are increased by high wind speed. Dust and sand concentration and the presence of large particles are raised with higher wind speeds. The presence of dust and sand is influenced by several factors such as terrain, wind, temperature, humidity and precipitation: a combination of these factors concur to damage products (places more subjected to these phenomena are deserts or seaside). It is mandatory to cover the packages of equipment with a sealed waterproof sheet.

Particularly critical are enclosed locations such as mills, cement mills, sawmills and similar places where sedimentation arises throughout the manufacturing process. Critical places are also locations where dust storms occur or around a vehicle in motion on dusty roads. We strongly recommend avoiding storage in these kinds of plants or places.

Salt mist

The atmosphere over the sea and in coastal areas is largely saline consisting of salt in the form of solid particles or of minute drops of saline solution also containing various other constituents. The constituent parts of a saline atmosphere are approximately equal to those found in the sea. If the equipment has to be stored in coastal areas, it is recommended to cover the packages of equipment with a sealed waterproof sheet.

Vibration and shock

Vibration and shock references are valid under the condition that contactors, and thermal and electronic overload relays are stored inside their original packages without any damage to them. Maximum values allowed for stationary sinusoidal vibrations are:

- displacement amplitude 0.3 mm for frequency range 2 Hz...9 Hz;
- acceleration amplitude 1 m/s² for frequency range 9 Hz...200 Hz;

Occasionally non-stationary vibration, including shock, is allowed if the shock response spectrum is type I (ref. IEC 60721-3-1) and peak acceleration is less than 40 m/s².

Seismic phenomena

The vibration nature of the ground motion (both horizontal and vertical) can be magnified in foundation-mounted products: for any given ground motion the magnification depends on the characteristic frequencies of vibration of the system (soil, foundation and product) and on the mechanism of damping. In seismic regions the equipment must be stored in a soil suitable to reduce the magnitude of vibrations. The storage area and storage support systems must not be vibration amplitude magnifying ones.

- If during the storage period the equipment is subjected to a moderate earthquake (persisting for 15 sec to 30 sec and Richter magnitude degree up to 3), no actions are required.
- If during storage period the equipment is subjected to a medium earthquake (persisting for more than 30 sec or Richter magnitude degree from 4 up to 6), it is mandatory to check every functionality.
- If during storage period the equipment is subjected to a strong earthquake (persisting for more than 60 sec or Richter magnitude degree higher than 6). We strongly recommend not putting the apparatus into service.

Flora and fauna

In geographical areas with warm damp climates, fauna and flora, especially insects and microorganisms, such as mold and bacteria, will find favorable conditions for life. Humid or wet rooms in buildings or rooms for processes producing humidity are suitable living spaces for rodents, insects and micro-organisms. The range of temperature in which molds may grow is from 0 °C to 40 °C, while the most favorable temperatures for many cultures is between 22 °C and 28 °C. If the surfaces of products carry layers of organic substances (e.g. grease, oil, dust) or deposits of animal or vegetable origin, such surfaces are ideal for the growth of molds and bacteria. It is important to avoid deposits from fauna, especially from insects, rodents and birds like:

- presence of the animals themselves
- building of nests or settlements
- feed stocks
- metabolic products and enzymes on the packages of the equipment
- It is also important to avoid deposits from all kinds of flora like on packages of the equipment:
- detached parts of plants (leaves, blossom, seeds, fruits, etc.)
- growth layers of cultures of molds or bacteria and effects of their metabolic products

Fire exposure

In case of possible fire exposure, the equipment must be stored following these indications:

- no presence of fire sources in the room
- absence of every kind of fuel in the room
- absence of combustible gases in the room
- at least one meter of distance from surfaces with external temperature over 70 °C

INSTALLATION AND DE-INSTALLATION

Electrical durability

Electrical durability for AC-1 utilization category - $U_e \leq 690\text{ V}$ for AF09 ... AF2050

Switching non-inductive or slightly inductive loads. The breaking current I_c for AC-1 is equal to the rated operational current of the load. Ambient temperature and maximum electrical switching frequency: see "Technical data".

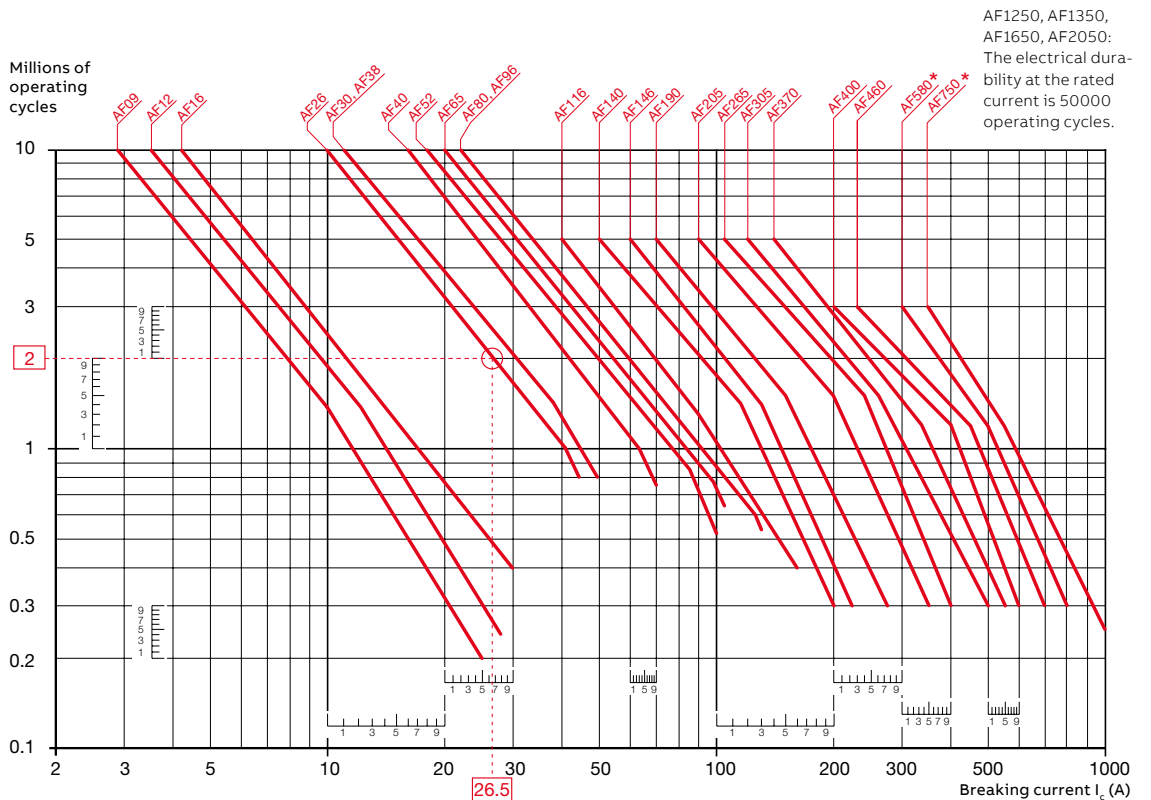

Example:

$I_c / \text{AC-1} = 26.5\text{ A}$ – Electrical durability required = 2 million operating cycles. Using the AC-1 curves above select the AF26 contactor at the intersection "O" (26.5 A / 2 million operating cycles).

Electrical durability for AC-3 utilization category – $U_e \leq 440$ V for AF09 ... AF1650

Switching cage motors: starting and switching off running motors. The breaking current I_c for AC-3 is equal to the rated operational current I_e (I_e = motor full load current). Ambient temperature and maximum electrical switching frequency: see "Technical data".

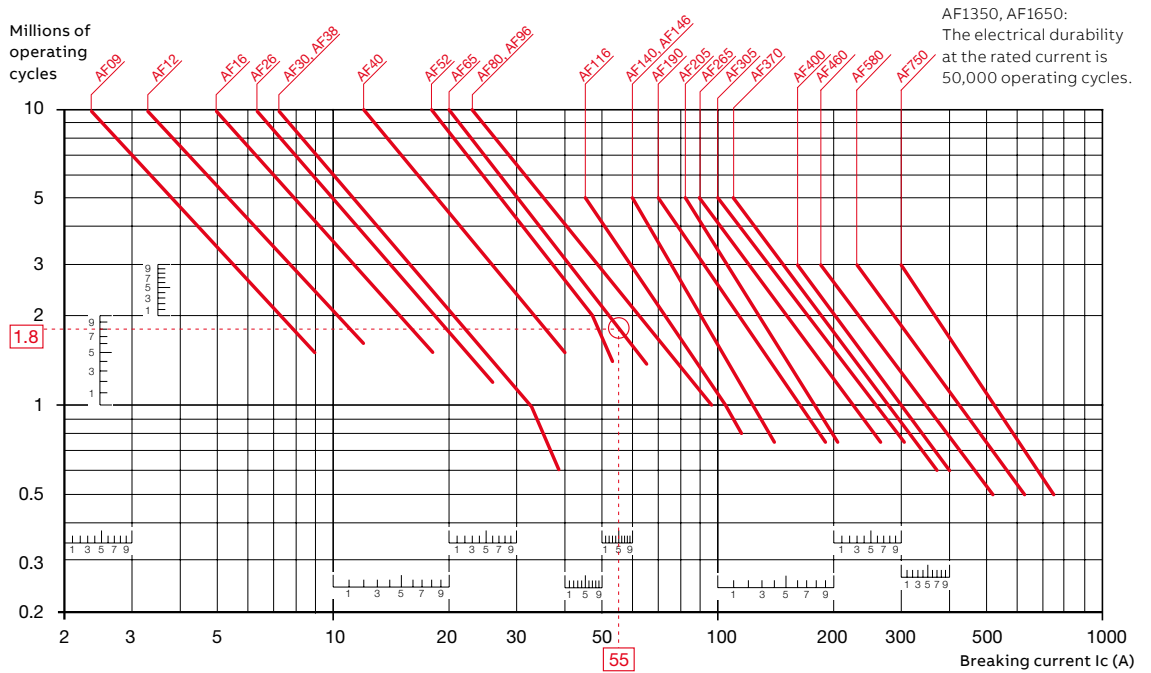

Note: * For AF580 and AF750 contacts need to be replaced after 750k operations.

Example:

Motor power 30 kW for AC-3 - $U_e = 400$ V and $I_e = 55$ A utilization – Electrical durability required = 1.8 million operating cycles. For AC-3: $I_c = I_e$. Select the AF65 contactor at intersection "O" (55 A / 1.8 million operating cycles) on the curves (AC-3 - $U_e \leq 440$ V).

INSTALLATION AND DE-INSTALLATION

Electrical durability for AC-3 utilization category – 440 V < U_e ≤ 690 V. for AF09 ... AF1650

Switching cage motors: starting and switching off running motors. The breaking current I_c for AC-3 is equal to the rated operational current I_e (I_e = motor full load current). Ambient temperature and maximum electrical switching frequency: see "Technical data".

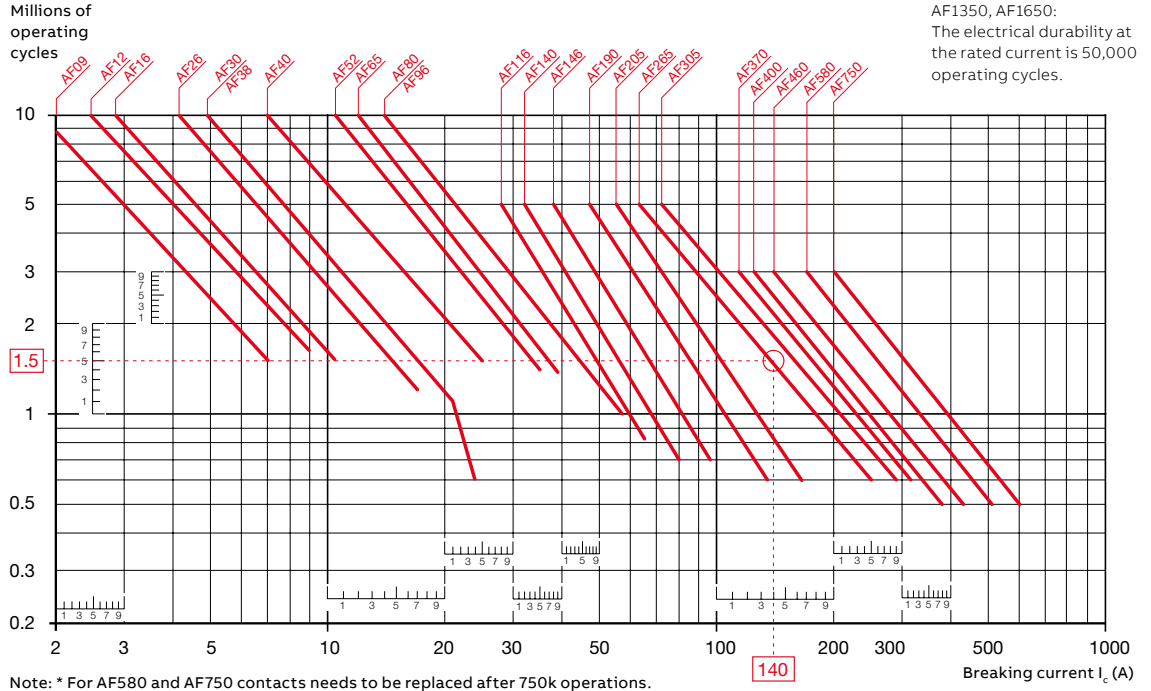

AF1350, AF1650:
The electrical durability at the rated current is 50,000 operating cycles.

Example:

Motor power 132 kW for AC-3 - U_e = 660 V and I_e = 140 A utilization – Electrical durability required = 1.5 million operating cycles. For AC-3: I_c = I_e. Select the AF265 contactor at intersection "O" (140 A / 1.5 million operating cycles) on the curves (AC-3 - 440 V < U_e ≤ 690 V).

Electrical durability for AC-2 or AC-4 utilization category – $U_e \leq 440\text{ V}$ by an Ambient temperature $\leq 60\text{ }^\circ\text{C}$ for AF09 ... AF370, $\leq 55\text{ }^\circ\text{C}$ for AF400 ... AF1650

Switching cage motors: starting, reverse operation and step-by-step operation. The breaking current I_c is equal to $2.5 \times I_e$ for AC-2 and $6 \times I_e$ for AC-4, keeping in mind that I_e is the motor-rated operational current ($I_e =$ motor full-load current). Maximum electrical switching frequency: see "Technical data".

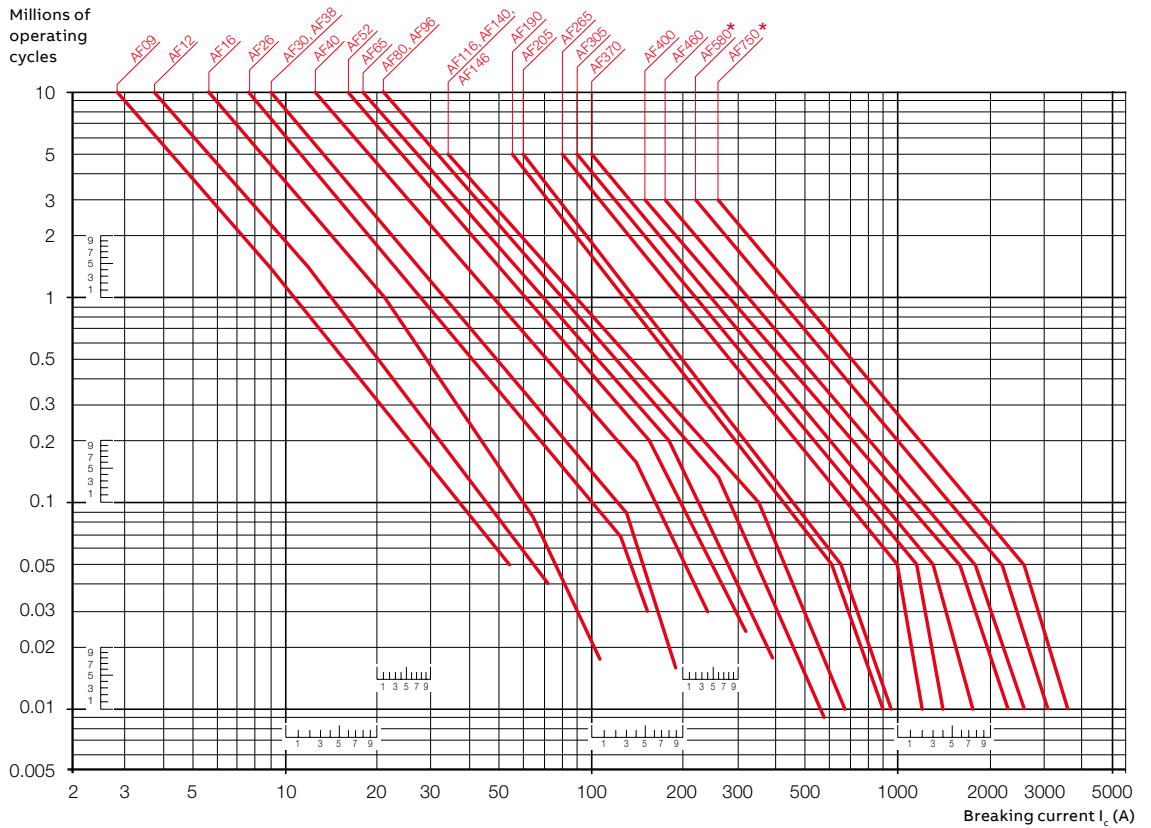

Note: * For AF580 and AF750 contacts need to be replaced after 750k operations.

INSTALLATION AND DE-INSTALLATION

Electrical durability for AC-2 or AC-4 utilization category – 440 V < U_e ≤ 690 V for AF09 ... AF750 by an ambient temperature ≤ 60 °C for AF09 ... AF370, ≤ 55 °C for AF400 ... AF750

Switching cage motors: starting, reverse operation and step-by-step operation. The breaking current I_c is equal to 2.5 × I_e for AC-2 and 6 × I_e for AC-4, keeping in mind that I_e is the motor-rated operational current (I_e = motor full load current). Maximum electrical switching frequency: see "Technical data".

Millions of operating cycles

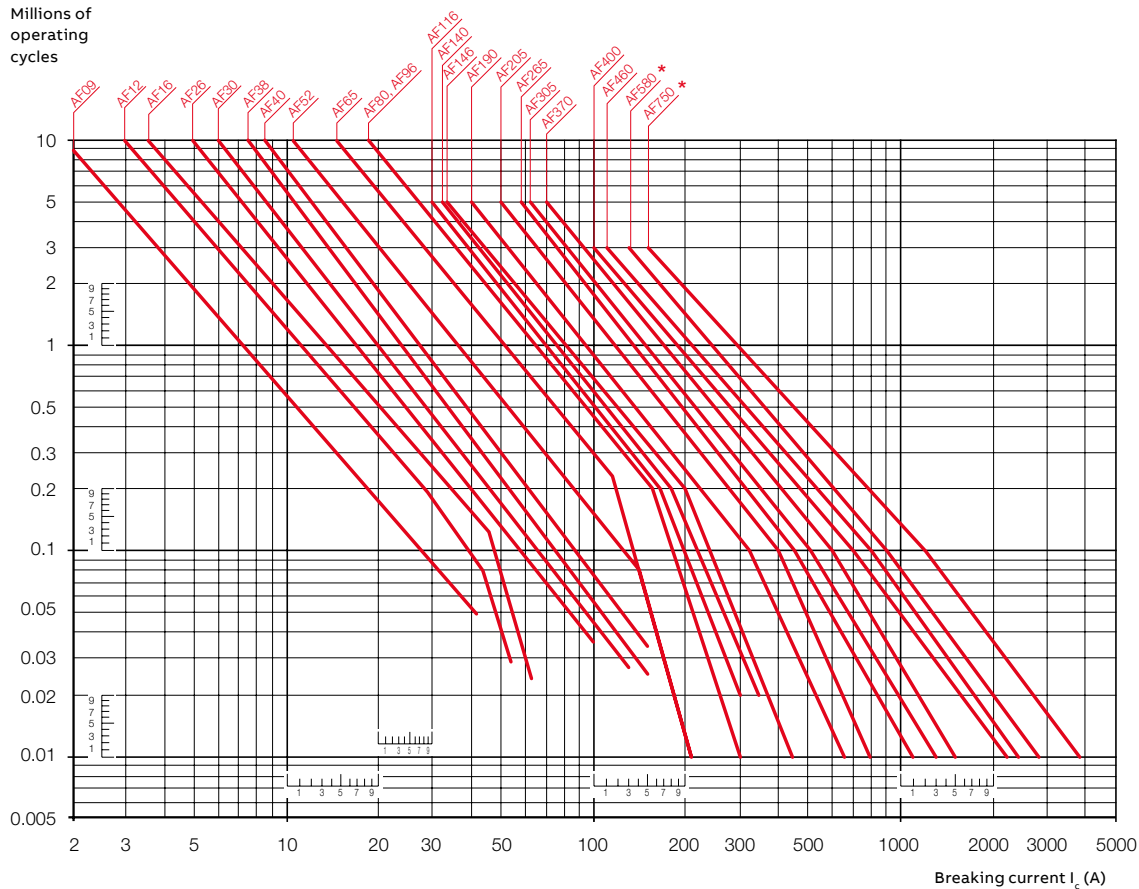

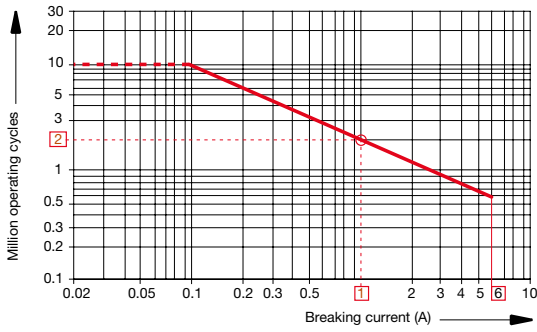

Electrical durability for AC-15 utilization category for AF09 ... AF96 contactor and NF contactor relays

AC-15 utilization category according to IEC 60947-5-1 / EN 60947-5-1:

- making current: $10 \times I_e$ with $\cos \phi = 0.7$ and U_e
- breaking current: I_e with $\cos \phi = 0.4$ and U_e .

These curves represent the electrical durability of the built-in or add-on auxiliary contacts in relation to the breaking current. The curves have been drawn for resistive and inductive loads up to 690 V, 40...60 Hz. AF09 ... AF96 contactor built-in auxiliary contacts
 1-pole and 4-pole CA4, 2-pole CAT4,
 1-pole CC4,
 2-pole CAL4 add-on auxiliary contacts.

Example:

Breaking current = 1 A

On the opposite curve at the intersection "O" 1 A the corresponding value for the electrical durability is approximately 2 million operating cycles.

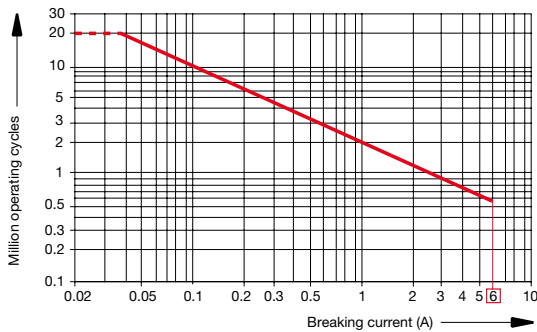

NF contactor relays.

(For add-on auxiliary contacts see curve above).

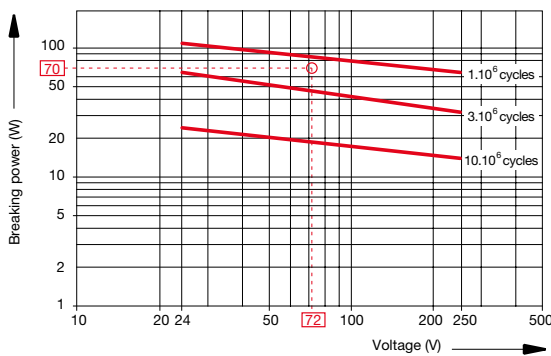

Electrical durability for DC-13 utilization category for AF09 ... AF96

DC-13 utilization category according to IEC 60947-5-1 / EN 60947-5-1: making and breaking current I_e and U_e .

AF09 ... AF96 contactor built-in auxiliary contacts

- 1-pole and 4-pole CA4, 2-pole CAT4,
- 1-pole CC4,
- 2-pole CAL4 add-on auxiliary contacts.

Example:

Breaking current = 1 A

On the opposite curve at the intersection "O" 1 A the corresponding value for the electrical durability is approximately 2 million operating cycles.

INSTALLATION AND DE-INSTALLATION

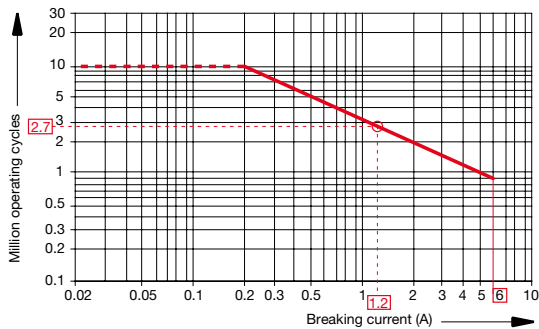

Electrical durability for AC-15 utilization category for AF116 ... AF2850

AC-15 utilization category according to IEC 60947-5-1 / EN 60947-5-1:

Making current: $10 \times I_e$ with $\cos \phi = 0.7$ and U_e

Breaking current: I_e with $\cos \phi = 0.4$ and U_e .

These curves represent the electrical durability of the add-on auxiliary contacts, in relation to the breaking current.

The curves have been drawn for resistive and inductive loads up to 690 V, 40...60 Hz.

AF116 ... AF2850 contactors auxiliary contacts
2-pole CAL18 and CAL19 add-on auxiliary contacts

Example:

Breaking current = 1.2 A

On the opposite curve at intersection "O" 1.2 A the corresponding value for the electrical durability is approximately 2.7 million operating cycles.

Pollution degree

The pollution degree refers to the environmental conditions for which the equipment is intended. The micro-environment determines the effects on the insulation; it includes all the factors that influence the insulation, such as climatic and electromagnetic conditions, generation of pollution, etc. For equipment fitted inside an enclosure and intended for storage (inside of it), the pollution degree of the environment is the one applicable for the enclosure. According to IEC 60947, in general conditions or unless otherwise stated by the relevant product standards, the pollution degree of industrial applications can be assumed as "Pollution degree 3" (Conductive pollution occurs, or dry, non-conductive pollution occurs which becomes conductive due to condensation).

Modality of storage

- Keep contactors and thermal and electronic overload relays in their original packages.
- Position the package of contactors and thermal and electronic overload relays on a horizontal surface – not in direct contact with the floor, but on a suitable support surface.

Putting into service

Before putting the equipment into service, it is mandatory to follow all the instructions included in the installation and maintenance documentation supplied with the contactors and thermal and electronic overload relay package or on the manufacturer's website.

NOTES

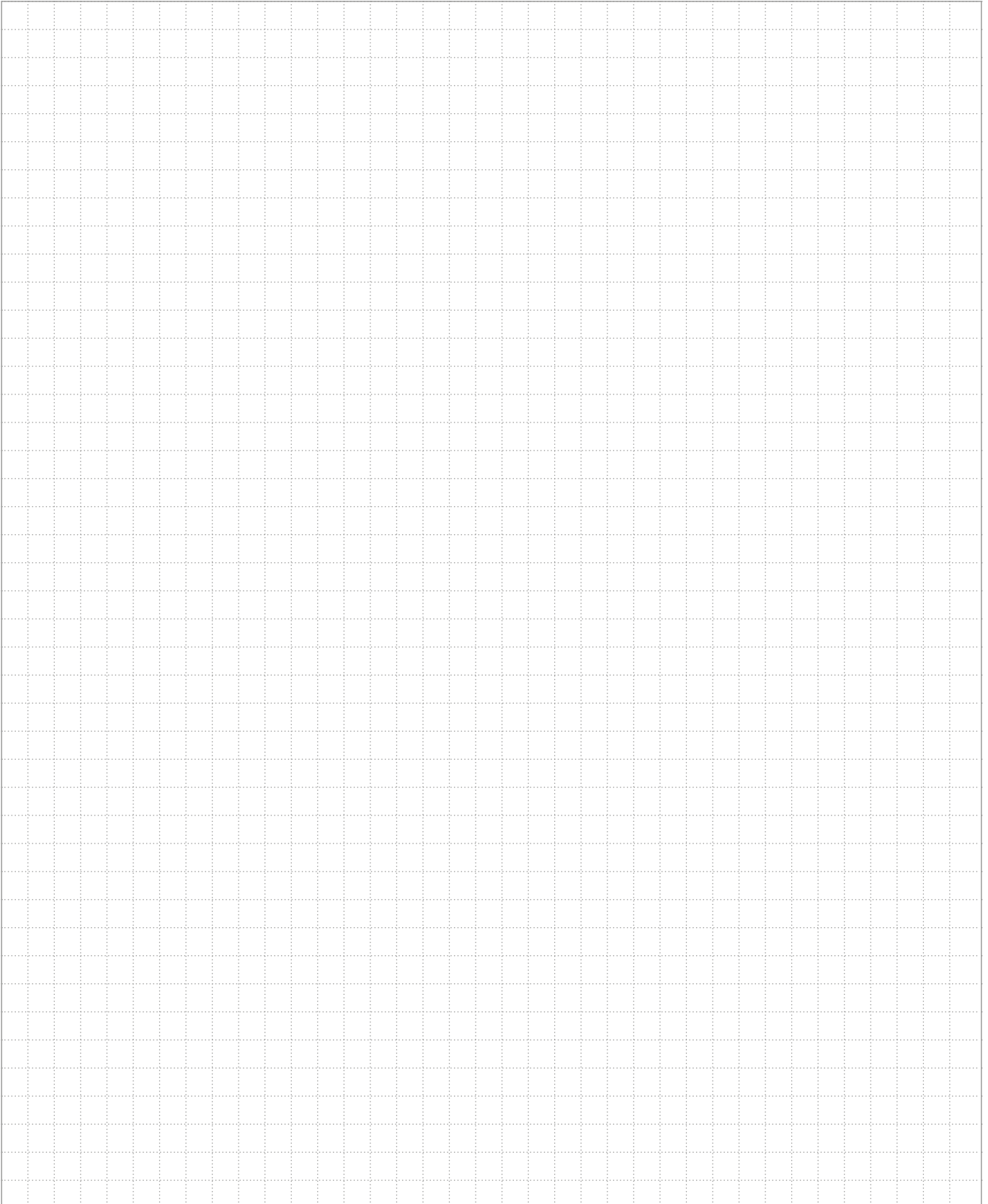

06

INSTALLATION AND COMMISSIONING FOR CONTACTORS

- 6/2** **Mounting**
- 6/4** **Changing main contacts, arc chutes,
and coils**
- 6/5** **Connection**

INSTALLATION AND COMMISSIONING FOR CONTACTORS

When mounting the contactors, observe the following instructions:

- The product must be installed in housing if there is a risk of contamination, heavy dust or an aggressive atmosphere.
- Dust deposits must be extracted.
- If foreign objects (e.g. drill chips) can get onto the devices, they must be removed from the mounting that covers the contactors.

Mounting

Contactors can be mounted as follows:

- Fixed on a 35 mm top hat rail according to IEC/ EN 60715 (35 × 15 or 35 × 7.5 mm)
- Screw fixing on wall/panel.

Mounting and dismantling on a DIN rail

The contactors sizes AF09 up to AF96 can be mounted on DIN rails according to DIN EN 60715 (35 × 15 or 35 × 7.5 mm).

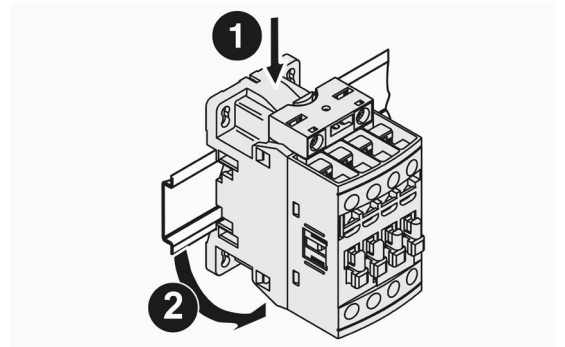
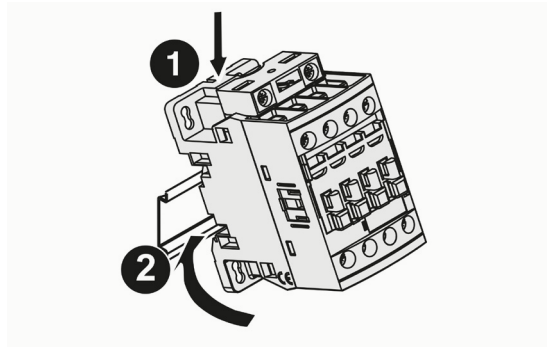

Dismantling of a contactor on 35 mm DIN rail mounting

Mounting

Place the device on the upper edge of the 35 mm DIN rail and push it downwards (1), until it snaps onto the lower edges of the DIN rail (2).

Dismantling

To dismantle, push the device downwards against the pull of the mounting spring (1) and remove the device with a swivel motion (2).

Mounting and dismantling with screw fixing on wall/panel

The contactors sizes AF09 up to AF96 can be also mounted with screws on one mounting plate or on a wall. The contactors sizes AF116 up to AF2850 can only be mounted with screws on one mounting plate or on a wall. Screw the contactor diagonally in the holes provided with screws washers and spring washers.

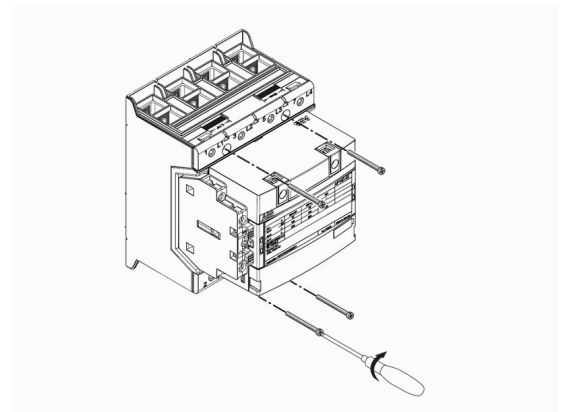
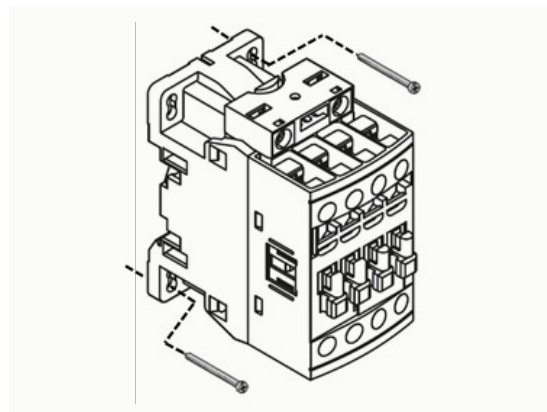



Contacteur Type	Screws	Max tightening torque
AF09... AF38	2 × M4	1.2 Nm (10 Lb.in)
AF40... AF96	2 × M6	1.5 Nm (13 Lb.in)
AF116... AF146	4 × M4	1.5 Nm (13 Lb.in)
AF190... AF460	4 × M5	2.8 Nm (25 Lb.in)
AF580... AF1250	4 × M6	3.4 Nm (30 Lb.in)
AF1350... AF2850	4 × M8	3.4 Nm (30 Lb.in)

These tightening torque values are only given as an indication. Whatever the case, end users must carry out further tests to validate the fixing solution in regard to the characteristics of the screws and washers used with the material of the plate.

Range	AF(S)09...38(Z) (K)(S), NF(Z) (K)(S)	AF(S)40...65	AF(S)80, AF96
Screw type	M4	M4 or M6	M6
Washer plate	according to ISO 7089 ext diam = 9 mm	according to ISO 7089 ext diam = 9 mm (for M4) or ext diam = 12 mm (for M6)	according to ISO 7089 ext diam = 12 mm (for M6)
Torque values	1.2 Nm (10 Lb.in)	1.2 Nm (10 Lb.in) [for M4] 1.5 Nm (13 Lb.in) [for M6]	1.5 Nm (13 Lb.in)

The number and the position of screws and the screwdriver type are indicated in the respective catalog for each range.

Minimum distances

There are no deratings necessary up to an ambient temperature of 70 °C for all contactors, even with a side to side mounting.

Mounting position

Mounting positions 1–5 are permitted for all AF contactors.

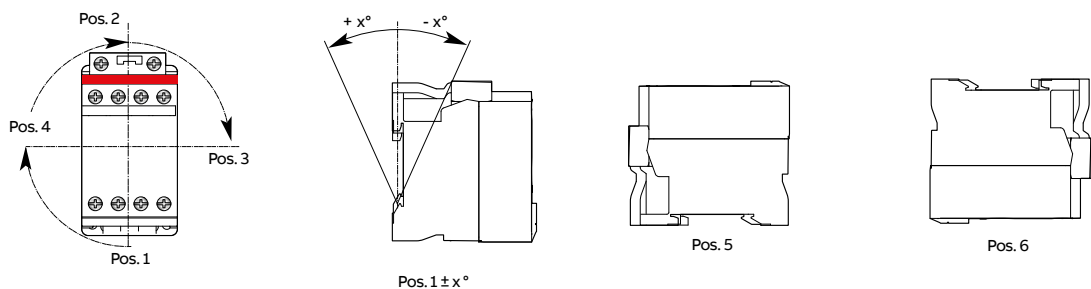

Max. N.C. built-in and add-on N.C. auxiliary contacts: see accessory fitting details for a contactor AF09 ... AF96 and an NF contactor relay.

INSTALLATION AND COMMISSIONING FOR CONTACTORS

Changing main contacts, arc chutes and coils

For the contactors AF116 ... AF2850 it is possible to change the main contacts, arc chutes and coils. The following chapters show the replacement of these spare parts.

Changing the main contact sets

- Loosen the screws of the removable front frame with a Torx T25 screwdriver and carefully remove the front frame from the contactor.
- Replace the arcing chamber with the new one.
- Move the contacts out of the contact carrier and push the new contacts into the contact carrier.
- Push the front frame of the contactor back onto the rear contactor half until the retaining clips engage.
- Screw the contactor halves (1.1 – 1.3 Nm or 9.8 – 11.5 Lb.in) with a screwdriver.

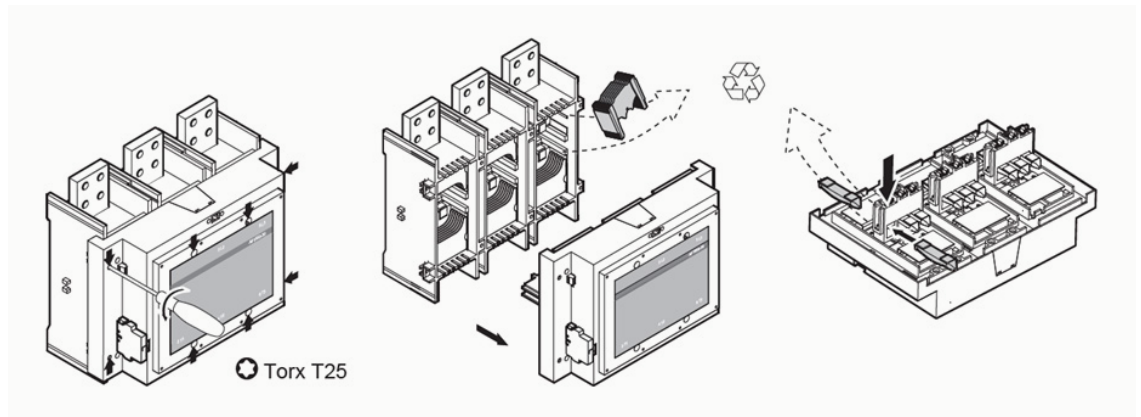

Changing the coils

- Loosen the screws of the removable front frame with a Torx T25 screwdriver and remove carefully the front frame from the contactor off.
- Remove the contact piece of the movable contact pieces from the rear half of the contactor.
- Remove the coil from the rear half of the contactor and insert the new coil.
- Hook the contact piece of the movable contact pieces into the rear half of the contactor.
- Push the front frame of the contactor back onto the rear contactor half until the retaining clips engage.
- Screw the contactor halves (1.1 – 1.3 Nm or 9.8 – 11.5 Lb.in) with a screwdriver.

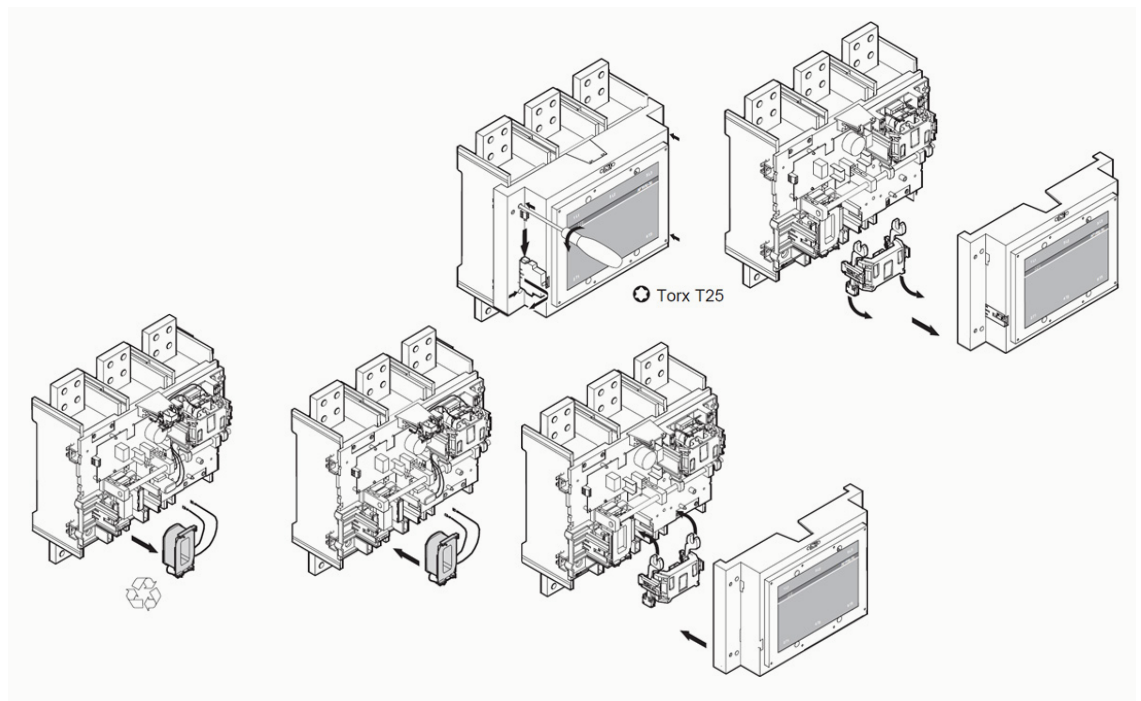

Connection

The AF contactors can be supplied either from the bottom or from the top (for non-UL applications).

Connection types

The contactors are available in the main circuit with the following connection types:

- AF09 up to AF38: screw terminals or push-in spring terminals
- AF40 up to AF96: screw terminals
- AF116 up to AF146: screw terminals or with screw connection with connection rails
- AF190 up to A2850: screw connection with connection rails

The contactors are available in the auxiliary circuit/control circuit with the following connection types available:

- AF09 up to AF38 push-in spring terminals
- AF09 up to AF2850: screw terminals

Push-in spring terminals allow connectors to be easily connected directly. The special contact spring allows easy insertion and guarantees a high level of contact quality.

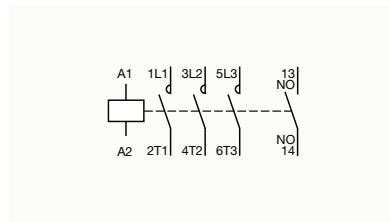

Terminal Name	Function / Designations
L1 ,L2 ,L3	Input main circuit – to the grid
T1, T2, T3	Output main circuit – to the load
A1, A2	Coil control circuit
13, 14	Auxiliary circuit – Normally open
21, 22	Auxiliary circuit – Normally closed

Auxiliary contacts have a two-digit designation:

- First digit: successive number of auxiliary contacts
- Second digit: function of the auxiliary contact e.g. 1-2 for openers or 3-4 for closers

In addition, 4-pole contactor relays are used for switching auxiliary and control circuits, so here also the digits are used as for the auxiliary contacts. Please see the following two examples:

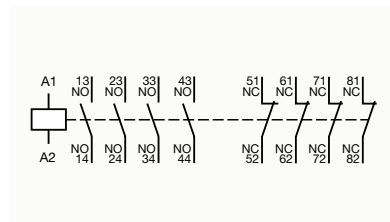



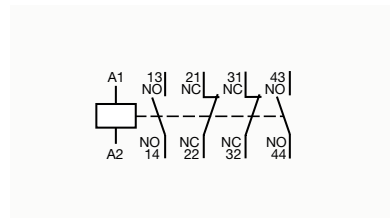





Terminal Name	Function / Designations
A1, A2	Coil control circuit
13, 14	Auxiliary circuit – Normally open
23, 24	Auxiliary circuit – Normally open
33, 34	Auxiliary circuit – Normally open
43, 44	Auxiliary circuit – Normally open

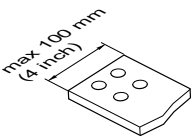

Terminal Name	Function / Designations
A1, A2	Coil control circuit
13, 14	Auxiliary circuit – Normally open
23, 24	Auxiliary circuit – Normally closed
33, 34	Auxiliary circuit – Normally closed
43, 44	Auxiliary circuit – Normally open

INSTALLATION AND COMMISSIONING FOR CONTACTORS



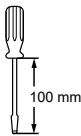



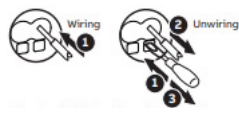

THERMINAL DESIGNATION AF2650 AND AF2850

	M12								
	45 Nm 398 lb.in								
									
		M 3.5 1 Nm -7 lb.in	ø 5.0	Pz 2	Solid / Stranded 2 × 1 ... 2.5 mm ² CU 75 C	Flexible 2 × 0.75 ... 2.5 mm ²	L > 3.5 mm L < 8 mm	100 mm	

Connection cross sections for push-in spring terminals technology

The following tables show the permissible conductor cross-sections for main connections and auxiliary conductor connections of the AF09-K up to AF38-K contactors:

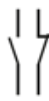
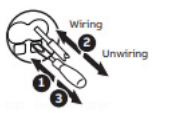
CONNECTION CROSS SECTIONS FOR PUSH-IN SPRING TERMINALS TECHNOLOGY AF09 ... AF38

Push-in / Spring	Wiring / Unwiring		Rigid / Solid					
		Wiring Push-in / Unwiring with screwdriver						
			ø 3 mm (0.12 in) × 0.5 mm (0.02 in)	1 or 2 × 1...2.5 mm ²	1 or 2 × 1...1.5 mm ²			mm L
		Wiring / Unwiring with screwdriver		1 or 2 × 1...2.5 mm ² 1 or 2 × AWG 18-14				10 mm (0.39 in)
				1 or 2 × 0.5...2.5 mm ²	1 or 2 × 0.5...1.5 mm ²	1 or 2 × 0.5...2.5 mm ²		

*only possible with spring technology

Installation instructions

Installation instructions for contactors can be accessed through the ABB Download Center <https://library.abb.com>.

All Categories > Products > Low Voltage Products and Systems > Control Product > Contactors

Drawings and 3D models

2D and 3D drawings for contactors and accessories can be accessed through the "ABB 3D portal" (<http://abb-control-products.partcommunity.com/portal/portal/abb-control-products>)

07

GENERAL PRODUCT OVERVIEW OVERLOAD RELAYS

- 7/2 Basic function**
- 7/5 Principle of operation**
- 7/8 Terms and ratings**
- 7/9 Enviromental and applicaton-specific factors**
- 7/11 Product offering**
- 7/14 Remote reset coil DRS-F and Remote Coil DRS-F-TF and DRS-F-EF**

GENERAL PRODUCT OVERVIEW OVERLOAD RELAYS

Basic function

Overload relays protect the motor and the installation against overloads. They are three pole electro-mechanical protection devices or three pole electronic protection devices with a release for overload protection. Furthermore, an overload relay is normally always used together with a contactor.

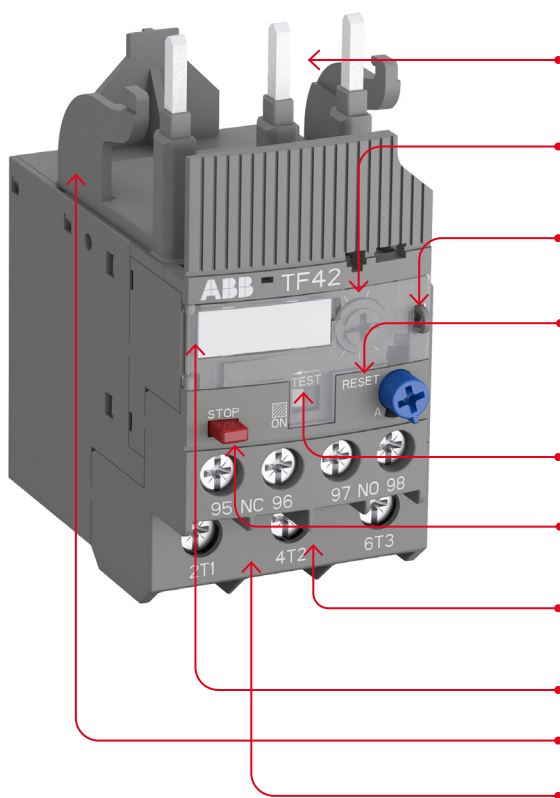

Input power terminals

They allow the connection directly to the suitable contactor.

Current setting dial

The dial makes it easy to set the device to the actual motor current.

Sealing

To close and seal the current setting dial when the plastic window is locked, the rated current can no longer be easily set.

RESET -manual or -automatic switch

In case of adjusting "RESET A", which means automatic reset after tripping, the motor may restart automatically. This automatic restart could injure persons and damage material.

TEST-Function

Allows testing of trigger mechanism.

STOP-Function

This button is used to manually open or close the contact that causes the coil to drop in a typical application

Auxiliary contact terminals

For the connection to the contactor coil. 1 × normally closed and 1 × normally open contact.

Label for marking

Assembly studs

Output power terminals

They allow the connection of up to two conductors with different cross-sections to the mains/main circuit.

Basic function of thermal overload relays: in this example the TF42-rated current can no longer be easily set.

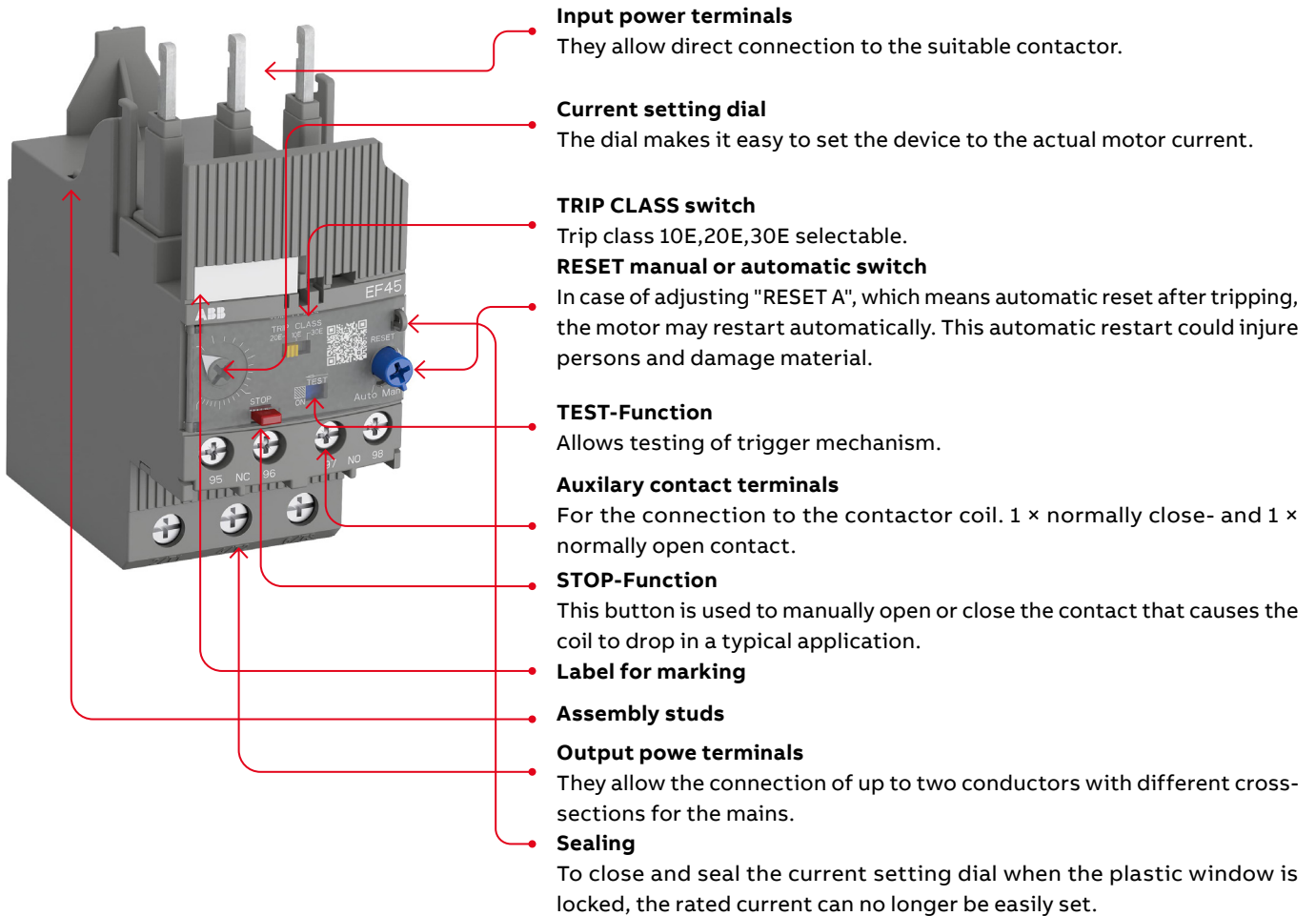

Basic function of electronic overload relays, in this example the EF45

GENERAL PRODUCT OVERVIEW OVERLOAD RELAYS

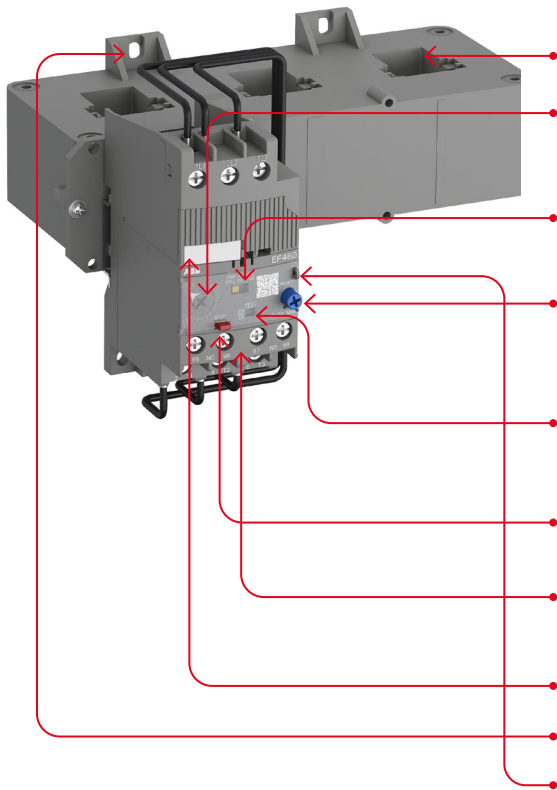

Feed-through current transformers

Allows the passage of conductors.

Current setting dial

The dial makes it easy to set the device to the actual motor current.

TRIP CLASS switch

Trip class 10E,20E,30E selectable.

RESET -manual or -automatic switch

In case of adjusting "RESET A", which means automatic reset after tripping, the motor may restart automatically. This automatic restart could injure persons and damage material.

TEST-Function and status indication

Allows testing of the trigger mechanism.

STOP-Function

This button is used to manually open or close the contact that causes the coil to drop in a typical application.

Auxiliary contact terminals

For the connection to the contactor coil. 1 × normally closed and 1 × normally open contact.

Label for marking

Mounting holes

Sealing

To close and seal the current setting dial when the plastic window is locked, the rated current can no longer be easily set.

Basic function of electronic overload relays with feed-through current transformers, in this example the EF460-500

Principle of Operation

Overload protection

An overload is defined as an operating condition in an electrically damaged circuit which causes an overcurrent. In compliance with international and national standards, overload relays have a setting scale in amperes, which allows the device to be adjusted to the motor current directly without any additional calculation. In compliance with international and national standards, the setting current is the rated current of the motor and not the tripping current (no tripping at $1.05 \times I_n$, tripping at $1.2 \times I_n$ shall occur in less than 2 hours; I_n = setting current).

Overload relays can be classified as follows:

- Bimetal thermal overload relays
- Electronic overload relays

The working principle of these two overload relays differs from each other.

Principle of operation of a thermal overload relay

Thermal overload relays operate on the principle of electrothermal properties with three compensated bimetal strips. The relay is connected into the motor circuit so that the motor current also flows through its poles. The bimetal strips are thus heated directly or indirectly (with larger currents using a measuring transformer) by the current, and if the current flow exceeds the set value, they bend.

Overload relays should always be used in combination with contactors. In applications where the bimetal strips heat up strongly, the trip contact is activated, which then interrupts the current supply to the coil of the contactor, thus de-energizing it and interrupting the current flow to the motor. This tripping time is inversely proportional to the current flow through the overload relay, so the higher the current flow, the faster it trips.

Principle of operation of an electronic overload relay

Electronic overload relays do not have a bimetal strip inside. Instead, they have current transformers to measure the amount of current flowing to the motor. The current is sensed by a PTC and the same is used to trip the circuit in the event of an overload fault.

The main advantage of electronic overload relays versus thermal overload relays is that the lack of a bimetal strip results in less heat loss inside the overload relay. In addition, electronic relays are more precise in current measurement. In addition, an electronic overload relay is more temperature compensated, has a larger current setting range and a wider temperature range (see the product specific ABB online datasheet for more details). All ABB overload relays are suitable for applications that require the frequent starting and stopping of motors.

GENERAL PRODUCT OVERVIEW OVERLOAD RELAYS

Release (tripping element)

Overload relays fulfill trip classes in accordance with IEC 60947-4-1 and UL 60947-4-1A. The trip class indicates the maximum tripping time from a cold state. The tripping class according to IEC 60947-4-1 indicates the maximum tripping time in seconds under specified test conditions at 7.2 times the setting current and specific tripping and non-tripping times for 1.5 and 7.2 times the setting current. Standard overload relays are equipped with an adjustable, inverse time-delay overcurrent release for overload protection.

Tripping times in accordance with IEC 60947-4-1 and UL 60947-4-1 can be seen in the figures "Tripping characteristics".

Class	Tripping time T_p [s] for thermal overload relays	Class	Tripping time T_p [s] for electronic overload relays
10A	$2 < T_p \leq 10$		
10	$4 < T_p \leq 10$	10 E	$5 < T_p \leq 10$
20	$6 < T_p \leq 20$	20 E	$10 < T_p \leq 20$
30	$9 < T_p \leq 30$	30 E	$20 < T_p \leq 30$

The information above is based on IEC 60947-4-1 and is intended for reference only.

Time-current characteristics (tripping characteristics)

Tripping times in accordance with the harmonized IEC 60947-4-1, UL 60947-4-1A and CSA C22.2 No. 60947-4-1 standards can be seen in the figures below. The tripping characteristics of the inverse time-delay thermal over-current release applies for direct current (DC) and alternating current (AC) with frequencies of 50/60 Hz.

For currents between three and eight times the current setting, the tripping time tolerances are $\pm 20\%$ for thermal overload relays and $\pm 15\%$ for electronic overload relays.

Tripping diagram for an overload relay

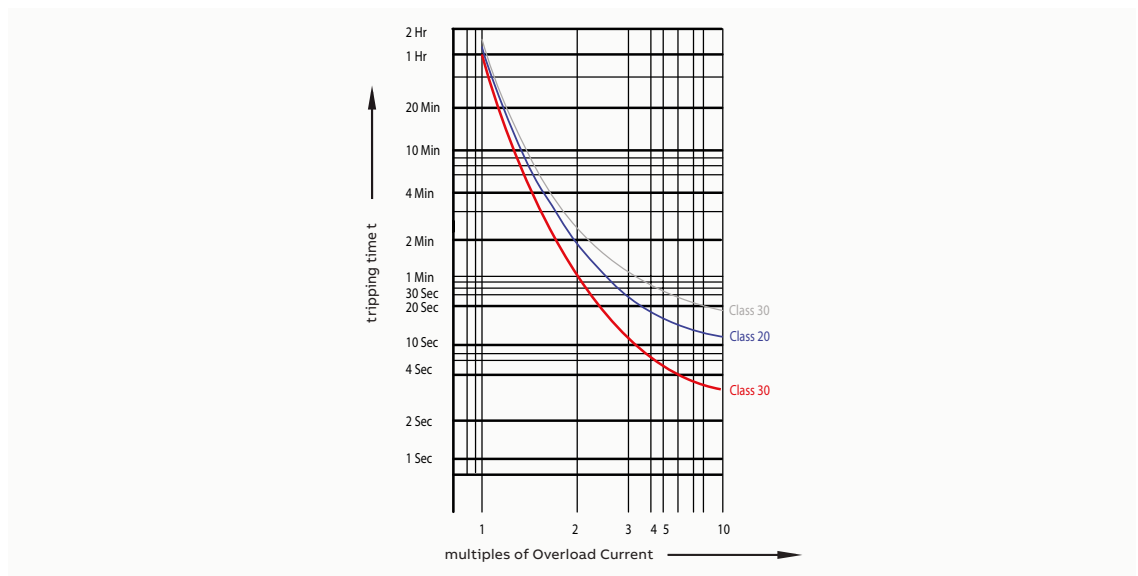

The tripping curve should always be considered together with standard IEC/UL60947-4-1. Below an extract from IEC/UL60947-4-1 section 8.2.1.5.1.1. Overload relays in normal operation shall meet the requirements of the following section when tested as follows:

- A) When an overload relay is installed at 1.05 times (105%) the current setting, it shall not trip from the cold condition in less than 2 h at the 1.05 times value, and the reference ambient temperature of + 20°C. Electronic overload relays
- B) If the current then rises to 1.2 times (120%) the current setting, tripping must occur in less than 2 h.

Phase loss sensitivity

According to IEC 60947-1-4-1, phase loss sensitivity is a characteristic of an inverse time-delay and thermal overcurrent release. In the event of a feed failure or severe phase unbalance, this ensures that the overcurrent relay trips. Timely tripping in the event of an excessively long two-phase feed prevents overcurrent in the remaining phases, which could damage the motor or other loads. Overload relays are designed to detect and trip these conditions to prevent load-side circuit and motor damage.

Limits of operation

No tripping within 2 hours	2 Pole: $1.0 \times I_e$
	1 Pole: $0.9 \times I_e$
Tripping within 2 hours	2 Pole: $1.15 \times I_e$
	1 Pole: $0 \times I_e$

The information above is based on IEC 60947-4-1.

Single-phase and direct current (DC) loads

With thermal overload relays, it is possible to protect single-phase loads or direct current (DC) loads: For these all three main poles must be connected in series (see figures below). This is not possible with the electronic overload relay; therefore, we suggest the use of thermal overload relays in such applications.

Connection diagram
for single-phase and
direct current.

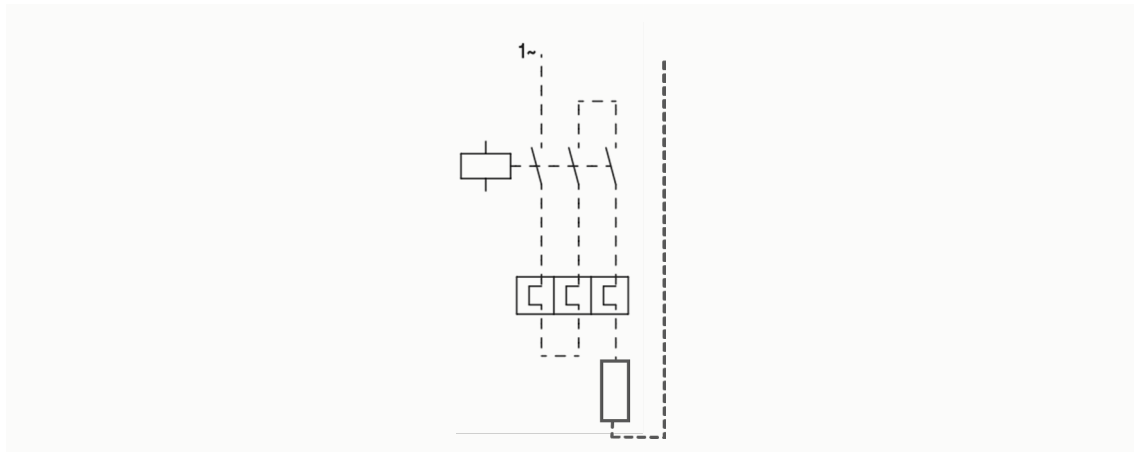

GENERAL PRODUCT OVERVIEW OVERLOAD RELAYS

Terms and ratings

Rated operational voltage (Ue)

The rated operational voltage of an overload relay is a value of phase-to-phase voltage which determines the possible application of the overload relay. This voltage needs to be considered in combination with a rated operational current and frequency.

Tripping curves for overload relays are easily accessible at ABB's Download Center.

<https://library.abb.com/>:

Categories > ABB Products > Low Voltage Products and Systems > Control Product > Contactors > Electronic Overload relays.
 Categories > ABB Products > Low Voltage Products and Systems > Control Product > Contactors > Thermal Overload relays.

Ambient air temperature compensation

Ambient air temperature compensation is realized by utilizing a bimetal strip which counteracts the working bimetals of the inverse time-delay thermal over-current release. This second bimetal strip is not heated by the motor current but bends only under the influence of the ambient air temperature. As a result, the influence of the ambient air temperature on the tripping characteristics of the overload relay is automatically compensated, at an ambient temperature of 20 °C (according to IEC 60947-4-1).

Diagram for the Ambient air temperature compensation.

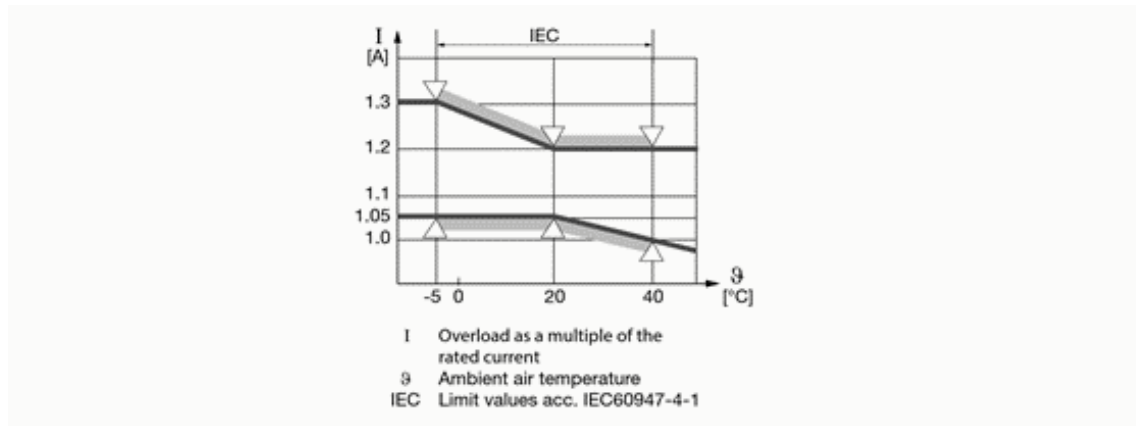

The ambient air temperature compensation is defined in IEC 60947-4-1 within a temperature range from -5 to +40 °C. ABB's thermal overload relays have an improved temperature compensation from -25 °C up to +60 °C. ABB's electronic overload relays even have a temperature compensation from -25 °C up to +70 °C.

Temperature rise of the overload relays

ABB tests overload relays according to Standard IEC 60947-1 tables 2 and 3. This table indicates different maximum temperature rise values for overload relays. Here you will find some examples for these temperatures rise limits:

From IEC 60947-1 Temperature-rise limits of terminals

Terminal material	Temperature-rise limits a, c in Kelvin [K]
Bare copper	60
Bare brass	65
Tin plated copper or brass	65
Silver plated or nickel-plated copper or brass	70
Other metals	b

a) The use in service of connected conductors significantly smaller than those listed in Tables 9 and 10 could result in higher terminals and internal part temperatures and such conductors should not be used without the manufacturer's consent since higher temperatures could lead to equipment failure.
 b) Temperature-rise limits to be based on service experience or life tests but not to exceed 65 K.
 c) Different values may be prescribed by product standards for different test conditions and for devices of small dimensions, but not exceeding by more than 10 K the values of this table.

From IEC 60947-1
Temperature-rise limits
of accessible parts.

Accessible parts	Temperature-rise limits a in Kelvin [K]
Manual operating means:	
Metallic	15
Non-metallic	20
Parts intended to be touched but not hand-held:	
Metallic	30
Non-metallic	40
Parts which need not be touched during normal operation b:	
Exteriors of enclosures adjacent to cable entries:	
Metallic	40
Non-metallic	50
Exterior of enclosures for resistors	200b
Air issuing from ventilation openings of enclosures for resistors	200b

- a) Different value may be prescribed by product standards for different test conditions and for devices of small dimensions but not exceeding by more than 10 K the values of this table.
- b) The equipment shall be protected against contact with combustible materials or accidental contact with personnel. The limit of 200 K may be exceeded if so, stated by the manufacturer. Guarding and location to prevent danger is the responsibility of the installer. The manufacturer shall provide appropriate information, in accordance with 5.3.

Environmental and application specific factors

Overload relays are suitable for use in many climates. They are intended for use in enclosed environments in which no severe operating conditions (such as dust, caustic vapors or hazardous gases) prevail. When installed in dusty and damp areas, suitable enclosures must be provided.

Ambient air temperature compensation and derating

According to the standards IEC 60947-4-1, UL 60947-4-1 and CAN/CSA-C22.2 no. 60947-4-1 it is required to test and validate relevant electrical data (e.g. rated currents, rated frequencies, rated voltages, etc.), typically at operating ambient air temperatures of -5 °C up to max. 40 °C.

ABB's thermal overload relays exceed this requirement by allowing compensated operation in ambient temperature ranges for single mounted products in IEC applications of -25 °C up to 60 °C. For group mounted products see Application Note: "Thermal Overload relays, high temperatures and group mounting" (1SAC200122W0001). Values between the temperature values can be linearly interpolated.

Duty cycles and restarting

To avoid issues with nuisance tripping, overload relays should not be operated at an arbitrary operating frequency. Applications involving up to 15 starts per hour are acceptable. Higher starting frequencies are acceptable if the duty ratio is lower and the motor's making current does not appreciably exceed six times the full-load current. The diagram below provides guideline values for starts-per-hour as a factor of the duty ratio (ON- vs. OFF-time) and the time required to start the motor t_a

Diagram of the duty cycles and restarting, for example, for a motor with a duty ratio of 60 percent and a start duration of 1 second, 40 starts per hour are acceptable. reset coil DRS-F.

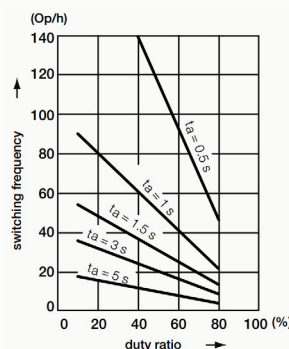

GENERAL PRODUCT OVERVIEW OVERLOAD RELAYS

Example:

The upper diagram represents the switched on and off periods of an overload relay. In the following example we have a 20 sec on- and 20-sec off-period which means we have a 50% duty ratio (the red point in the above diagram).

The graph which can be seen below represents the motor current. In our example, we have 1 sec starting current. After 1 sec, our motor goes down to its nominal current. When we apply these assumptions to the table below, we have 50 operations per hour as marked with red dots.

Example of the duty cycles and restarting

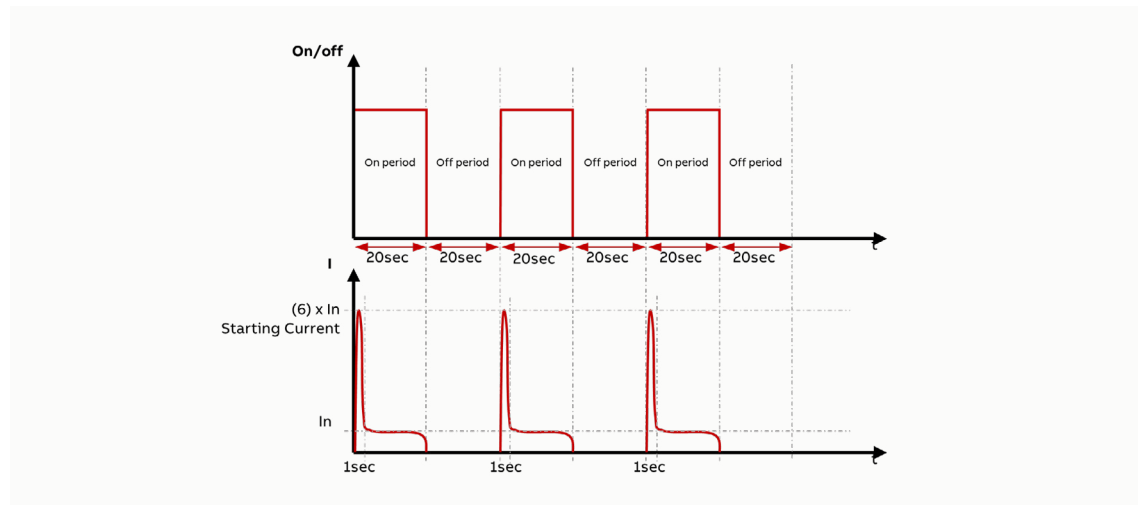

After tripping, the overload relays need to cool down before the overload relay can be reset.

Application with Frequency Converters

EF electronic overload relays are not suitable for operation with frequency converters (VFDs, Drives), neither on the line side nor on the load side of frequency converter. In fact, their associated harmonics can cause nuisance tripping of electronic overload relays. For application with frequency converter, thermal overload relays are preferred solutions.

Product offering

ABB provides a comprehensive overload relay. Worldwide the overload relay device types are divided into two ranges to simplify selection, coordination, and installation:

- Thermal relay from 0.1 A to 200 A
- Electronic relays from 0.1 A to 1250 A

THERMAL OVERLOAD RELAY

Product range of all overload relay.



	TF42	TF65	TF96	TF140DU	TA200DU
Phase loss sensitivity	X	X	X	X	X
Trip Class	10	10	10	10	10
Rated operational current I_e	0.1 ... 38 A	22 ... 67 A	40 ... 96 A	66 ... 142 A	66 ... 200 A
Suitable for 1-phase	X	X	X	X	X
Width	45 mm	54.9 mm	69.6 mm	89 mm	104 mm
Suitable for	AF09, AF12, AF16, AF26, AF30, AF38	AF40, AF52, AF65	AF80, AF96	AF116, AF140	A145, A185, AF145, AF185, AF190, AF205
Ambient Air Temperature:	-25 ... +60 °C	-40 ... +70 °C	-40 ... +70 °C	-25 ... +55 °C	-25 ... +55 °C

ELECTRONIC OVERLOAD RELAY

Product range of all overload relay.



	EF19	EF45	EF65	EF96	EF146
Phase loss sensitivity	X	X	X	X	X
Trip Class	10E, 20E, 30E	10E, 20E, 30E	10E, 20E, 30E	10E, 20E, 30E	10E, 20E, 30E
Rated operational current I_e	0.1 ... 18.9 A	9 ... 45 A	20 ... 70 A	20 ... 100 A	54 ... 150 A
Suitable for 1-phase					
Integrated current transformer					
Width	44.4 mm	45 mm	70 mm	70 mm	89 mm
Suitable for	AF09, AF12, AF16, AF26, AF30, AF38	AF26, AF30, AF38	AF40, AF52, AF65	AF80, AF96	AF116, AF140, AF146
Ambient Air Temperature:	-25 ... +70 °C	-25 ... +70 °C	-25 ... +70 °C	-25 ... +70 °C	-25 ... +70 °C

GENERAL PRODUCT OVERVIEW OVERLOAD RELAYS

Product range of all overload relay.



	EF205	EF370	EF460	EF750	EF1250DU
Phase loss sensitivity	X	X	X	X	X
Trip Class	63 ... 210 A	10E, 20E, 30E	10E, 20E, 30E	10E, 20E, 30E	10E, 20E, 30E
Rated operational current I_e	0.1 ... 18.9 A	115 ... 380 A	150 ... 500 A	200 ... 800 A	350 ... 1250 A
Suitable for 1-phase					
Integrated current transformer					
Width	105 mm	105 mm	186 mm	244 mm	105 mm
Suitable for	AF145, AF185, AF190, AF205	AF210, AF260, AF300, AF265, AF305, AF370	AF400, AF460	AF580, AF750	AF1350, AF1650, AF1350T, AF1650T
Ambient Air Temperature:	-25 ... +70 °C	-25 ... +70 °C	-25 ... +70 °C	-25 ... +70 °C	-25 ... +70 °C

Thermal overload relays – TF42, TF65, TF96, TF140DU; TA200DU

The thermal overload relays are economical electromechanical protection devices for the main circuit. They offer reliable protection for motors in the event of overload or phase failure. The thermal overload relays are three pole relays with bimetal tripping elements. The motor current flows through the bimetal tripping elements and heats them directly and indirectly. In case of an overload (overcurrent), the bimetal elements bends as a result of the heating. This leads to a release of the relay and a change of the contacts switching position (95-96 / 97-98).

Temperature rise values for overload relays. Here you will find some examples for these temperature rise limits:

- Manual or automatic reset selectable
- Phase loss sensitive acc. to IEC/EN 60947-4-1
- TEST and STOP function – Trip indication on the front
- Temperature compensation
- Suitable for AC three- and single-phase and for DC applications

Electronic overload relays – EF19, EF45, EF65, EF96, EF146, EF205, EF370

These are electronic overload relays that do not need an additional external supply. They offer reliable protection for motors in the event of overload or phase failure. As easy to use as a thermal overload relay and compatible with standard motor applications, the electronic overload relay is convincing, above all, due to its wide setting range, high accuracy, high operational temperature range and the possibility to select a trip class (10E, 20E, 30E). Further features are the temperature compensation, trip contact (N.C.), signal contact (N.O.), automatic or manual reset selectable, trip-free mechanism, STOP and TEST function and a trip indication. The overload relays are connected directly to the contactors.

- Manual or automatic reset selectable
- Phase loss sensitive acc. to IEC/EN 60947-4-1
- TEST and STOP function – Trip indication on the front
- Temperature compensation



Electronic overload relays – EF460, EF750, EF1250DU

The EF460, EF750 and EF1250DU are self-supplied electronic overload relays, which means no extra external supply is needed. It offers reliable protection for motors in the event of overload or phase failure. These overload relays are powered by current transformers with linear characteristics and do not require extensive adjustments. As easy to use as a thermal overload relay and compatible with standard motor applications, the electronic overload relay is convincing, above all, due to its wide setting range, high accuracy, high operational temperature range and the possibility to select a trip class (10E, 20E, 30E). Further features are the temperature compensation, trip contact (N.C.), signal contact (N.O.), automatic or manual reset selectable, trip-free mechanism, STOP and TEST function and trip indicator. Busbar kits are available as accessory for contactor mounting.

- Manual or automatic reset selectable
- Phase loss sensitive acc. to IEC/EN 60947-4-1
- TEST and STOP function – Trip indication on the front
- Temperature compensation
- Suitable for three- and single-phase applications
- With ATEX certification

Accessories

Overload relays are offered with many accessories. For example, the overload relays can be extended with a remote reset coil or remote a stop coil, which can be connected on the front side to save space. With the help of separately available adapters, the overload relays can be easily and quickly assembled into compact overload relays with screw terminals on the top and bottom sides.

Increasing functionality	Remote reset coil DRS-F Remote stop coil DRS-F-TF	
Mounting	Single mounting kit DB19EF, DB42, DB42EF, DB65, DB96	
External operation	Reset push button KPR-101L	
	Holder for toolless direct mounting WRH-F Bowden wire with actuator for WRH-F WRB-400, WRB-600, WRB-1000	

FUNCTIONALITY OF THE REMOTE RESET AND REMOTE STOP

Name	Suitable for	Stop function	Reset function	AC	DC
DRS-F	TF42 – TF96		•	•	•
	EF19 – EF1250		•		•
DRS-F-TF	TF42 – TF96	•			•
DRS-F-EF	EF19 – EF1250	•		•	•

GENERAL PRODUCT OVERVIEW OVERLOAD RELAYS

Remote reset coil DRS-F and Remote Coil DRS-F-TF and DRS-F-EF

The DRS-F-01 remote reset coil is used for decentralized resetting of the overload relays, for example, via a pilot device on the control panel door. The overload relay must first be set to "manual reset" to ensure correct operation. It should also be noted that the coil is not approved for continuous operation (pulse duration 0.2 ... 0.35 s) with a duty time of 1.5%.

Remote reset coil DRS-F.

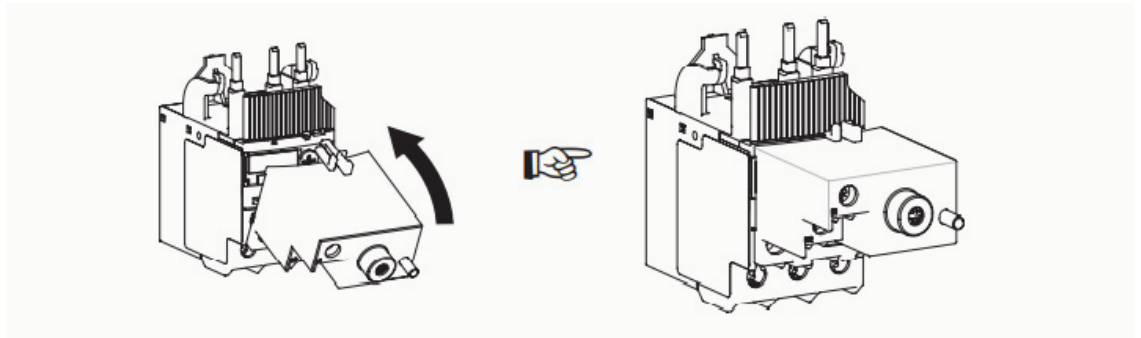

Connection example for Remote Reset Coil DRS-F

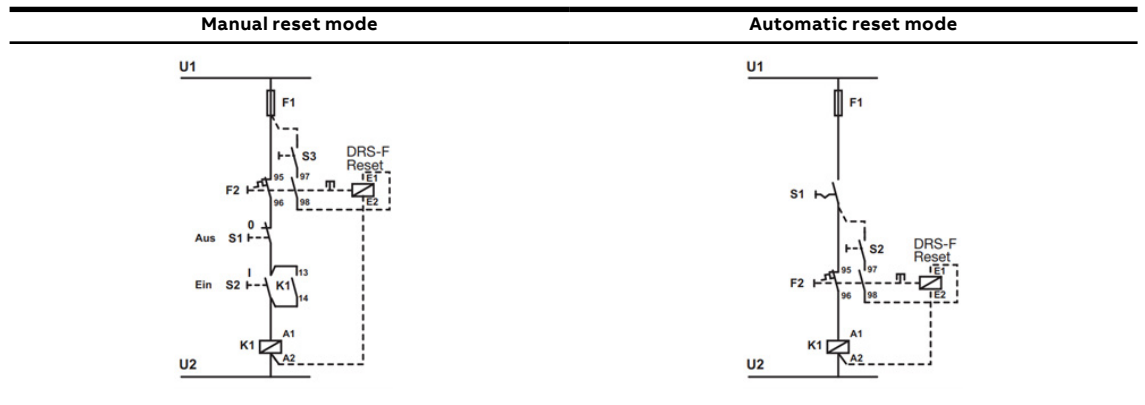

Connection example for Remote Coil DRS-F-TF and DRS-F-EF

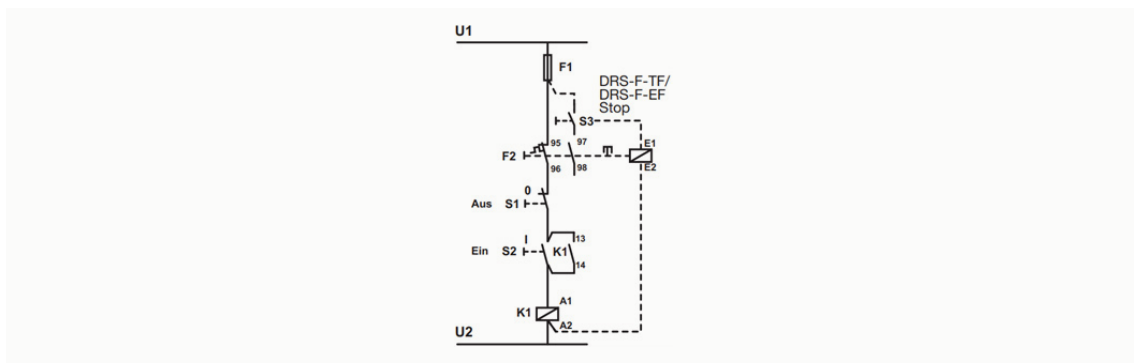

Single mounting kit DB19EF, DB42, DB42EF, DB65, DB96

With the help of separately available single mounting kits, overload relays can be easily and quickly assembled into compact overload relays with screw terminals on the top and bottom sides. Additionally, these kits allow an overload relay to be mounted without a contactor on a DIN rail or mounting plate.

- How to mount overload relay to the mounting kit:

Remote single mounting kit.

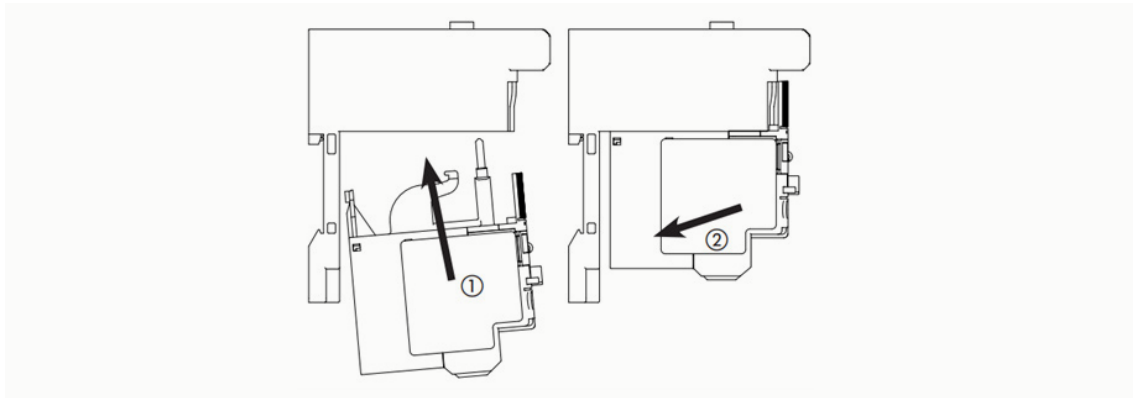

- How to mount this combination to the DIN rail:

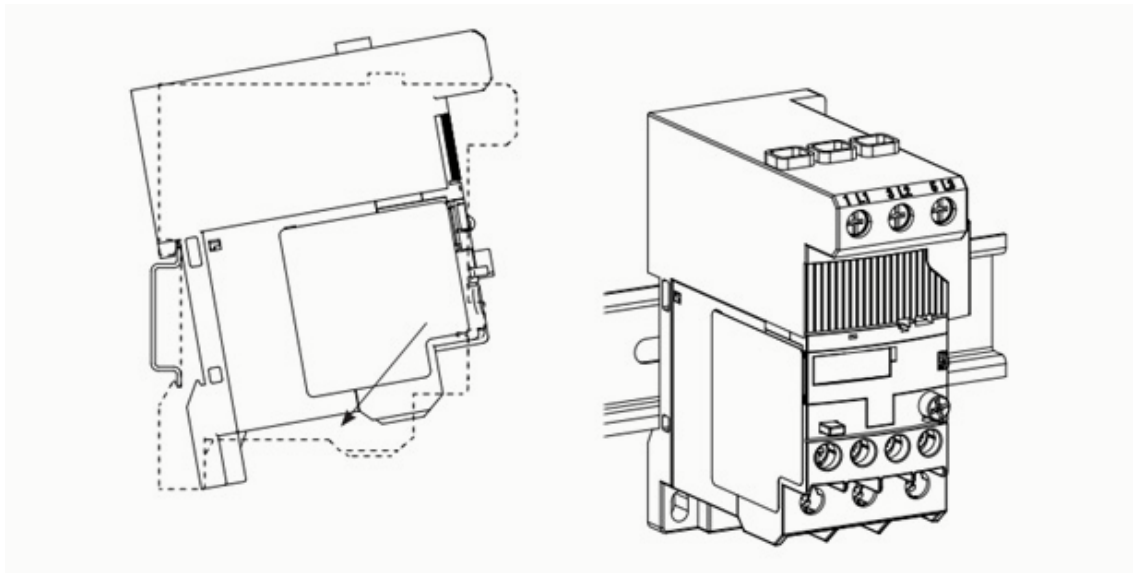

08

SELECTION CRITERIA

- 8/2 Sizing overload relays for motor applications**
- 8/2 Selected Optimized Coordination (SOC)**

SELECTION CRITERIA

Sizing overload relays for motor applications

Overload relays should be sized based on the rated current (for UL full-load amps (FLA)) of the motor. The rated operational current I_e of an overload relay represents the maximum current rating of the device. Overload relays should be selected so that the motor current rating falls between these ranges. If the thermal setting ranges of two devices overlap for the intended motor current.

Selected Optimized Coordination (SOC)

To help in selecting the right ABB product in combination (protection and switching) for the particular application, the "Selected Optimized Coordination" (SOC) web tool is very useful.

In order to guarantee the best performance and the longest lifetime, devices involved in the applications mentioned above (short-circuit protection devices, contactors, overload relays, soft starters) need to be coordinated.

The coordination between devices cannot be determined directly: tests in power laboratories must be carried out to qualify the coordination type at low fault and high fault currents according to IEC or UL standards. ABB coordination tables are the results of such tests and represent the ABB offering in terms of motor starting and protection, selectivity, back-up and switch-disconnector protection.

In the SOC all available ABB coordination tables are stored and easily accessible. The following chapter will guide you on the main tasks and user interactions.

Screenshot from SOC

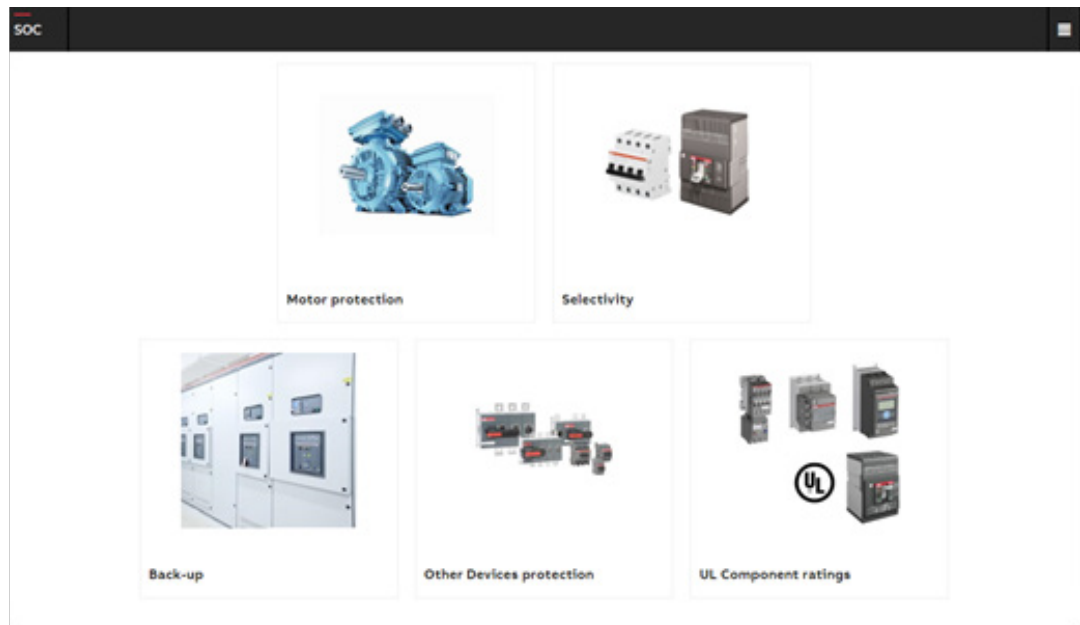

Under the interface "Motor protection" the following filters are available:

- type of protection device
- rated voltage
- short-circuit current
- starter type
- coordination type
- overload relay
- motor rated power

For example, if you are looking for products for motor protection where an overload relay is used as an overload protection device in a plant where the rated voltage is 400 V AC and the IE3/IE4 Motor Rated Power is 2.2kW, select the desired overload relay type in the right field:

Screenshot from an example on SOC

The screenshot shows the SOC software interface with the following settings:

- Standard:** IEC
- Starting type:** Normal start
- Motor Efficiency Class - Design:** Any
- Table status:** Any

The filter results table is as follows:

Starter Type	Rated voltage	Motor rated power	Rated short-circuit cur...	Coordination type	Protection device	Overload protection
Direct-on-line starter	400 V AC	2.2 kW	50 kA	IEC Type 1	Switch fuse	Embedded
Star-Delta starter	415 V AC	3 kW	65 kA	IEC Type 2	Molded case circuit-b	Thermal overload rela
	440 V AC	4 kW	100 kA		Manual motor starter	Electronic overload re
	500 V AC	5.5 kW				Universal motor contr
	690 V AC	7.5 kW				
		9 kW				
		11 kW				

Below the filter results, there are two detailed tables for the selected configuration:

1 Manual motor starter, 400 V AC, 50 kA, Direct-on-line starter, Coordination type: IEC Type 2, Overload protection: Thermal overload relay, Motor Efficiency Class - Design: IE1/IE2/IE3/IE4 N/H, (MO132 - A - TA)

Motor	Protection device	Contactor	Overload protection	Table
Motor rated power	Rated Current (Ie)	Type	Type	Max allowed load current
2.2 kW	4.9 A	MO132-6.3	TA25DU-6.5	6.25 A

2 Manual motor starter, 400 V AC, 50 kA, Direct-on-line starter, Coordination type: IEC Type 2, Overload protection: Thermal overload relay, Motor Efficiency Class - Design: IE1/IE2/IE3/IE4 N/H, (MO + AF + TF - IE3)

Motor	Protection device	Contactor	Overload protection	Table
Motor rated power	Rated Current (Ie)	Type	Type	Max allowed load current
2.2 kW	4.9 A	MO132-6.3	TF42-S.7	5.7 A

SOC shows the right protection device for the selected application depending on the coordination type. Click on >> to see the complete table

Screenshot from an example on SOC

The screenshot shows a detailed table for the configuration: MMS, 400 Vac, 35 kA, DOL-NS, Coordination type: IEC Type 1, Overload relay: Embedded, Motor efficiency class IE1 + IE2 + IE3.

Motor	MMS	Contactor	Table
Motor Rated Power [kW]	Inst.Trip.Current [A]	Type	Max allowed load current [A]
2.2	78.75	AF09	6.30

The 'Table' column in the above table contains a '>>' link, which is highlighted with a red box in the screenshot.

09

INSTALLATION AND COMMISSIONING FOR OVERLOAD RELAYS

- 9/2** **Mounting**
- 9/3** **Connection**
- 9/7** **Motor current setting procedure**
- 9/7** **Overload trip test for EOL**
- 9/8** **Restart after tripping**
- 9/8** **ATEX Operating instructions**
- 9/8** **Installation instructions**
- 9/8** **2D drawings and 3D models**

INSTALLATION AND COMMISSIONING FOR OVERLOAD RELAYS

Mounting

Overload relays with integrated current transformers (TF42 ... TF140, TA200, EF19 ... EF370) can be mounted directly on the contactor without additional adapters (see Figure A), and additional mounting of the overload relay on the DIN rail is also not required. For the overload relays with external current transformers (EF460 and EF750), the lines or current bars to be measured are led through the current measuring transformers (see Figure B). Here, additional mounting of the overload relay is required on a DIN rail or control cabinet rear panel.

Fig. A
Mounting of a overload relay with integrated current transformer (not for TA200DU and EF370)

Fig. B
Mounting of a overload relay with external separate current transformer

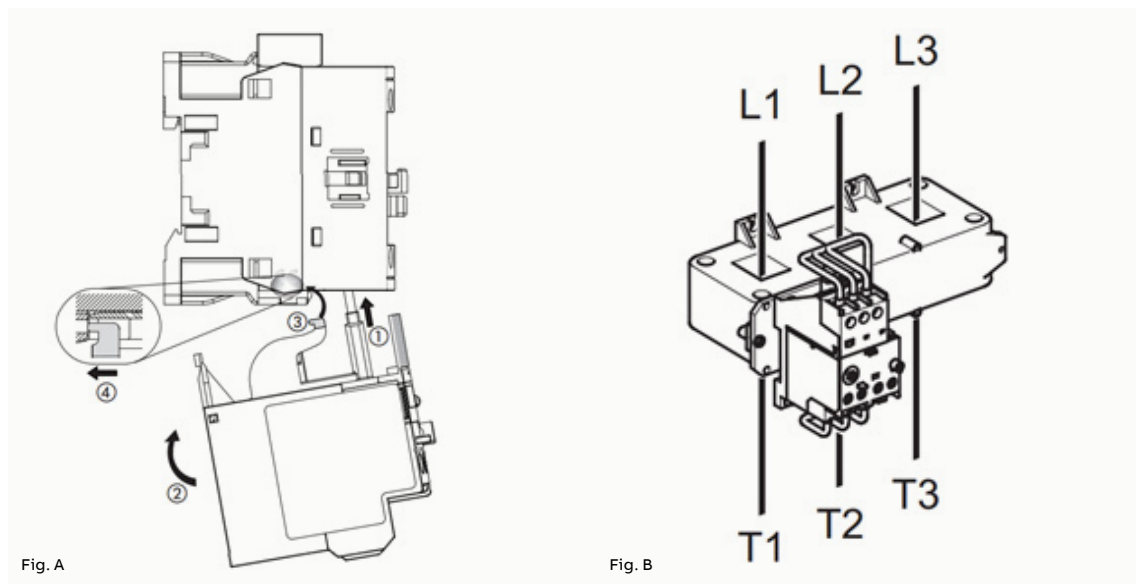

Mounting position and minimum distances

When mounting the overload relays, keep the following clearances to grounded or live parts and insulated conduit ducts:

- Single installation: there must be no directly attached contactor and there has to be a minimum gap of 9 mm to the left and to the right.
- Group installation: the contactor must be mounted directly or the gap to the left or the right must be less than 9 mm.

For group mounted products shown in Application Note: "[Thermal Overload Relays High temperatures and group mounting](#)" Values between the temperature values can be linearly interpolated.

Mounting position

Mounting positions 1 until 6 are permitted for overload relays.

Screenshot from SOC

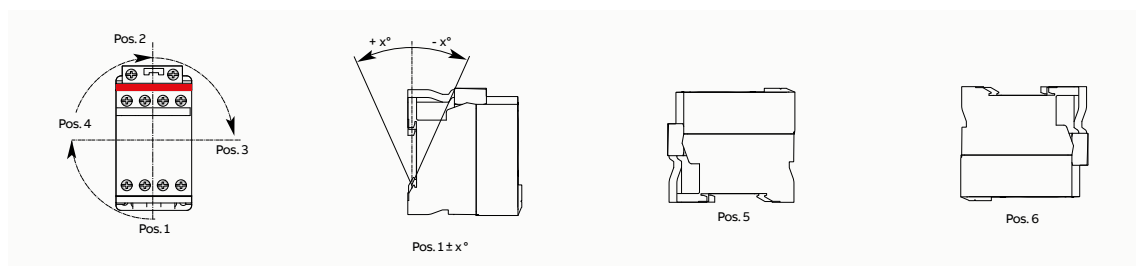

If the overload relay is mounted directly on a contactor, the requirements of the contactor should always be taken into account, these can be found in the [Contactor Guide](#).

Connection

The simplest way to start a squirrel-cage motor is to connect it directly to the mains. In this case, a switching device, such as a contactor, is the only starting device required, however, it should be noted here that it leads to a high starting current, which is often many times the rated current of the motor.

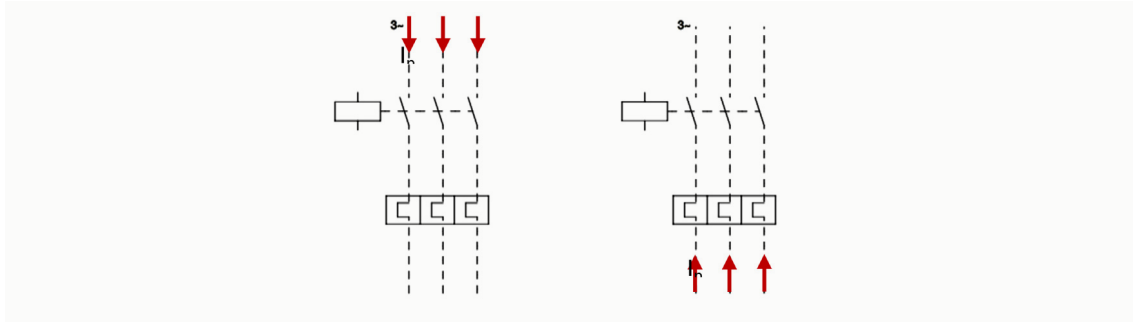

Direct-on-line (DOL) starting

The simplest way to start a squirrel-cage motor is to connect it directly to the mains supply. In this case, switchgear such as a contactor is the only starting equipment required. However, the limitation of this method is that it results in a high starting current, often several times the rated current of the motor. Also, the starting torque is very high, and may result in high stresses on the couplings and the driven application. Even so, it is the preferred method unless there are special reasons for avoiding it.

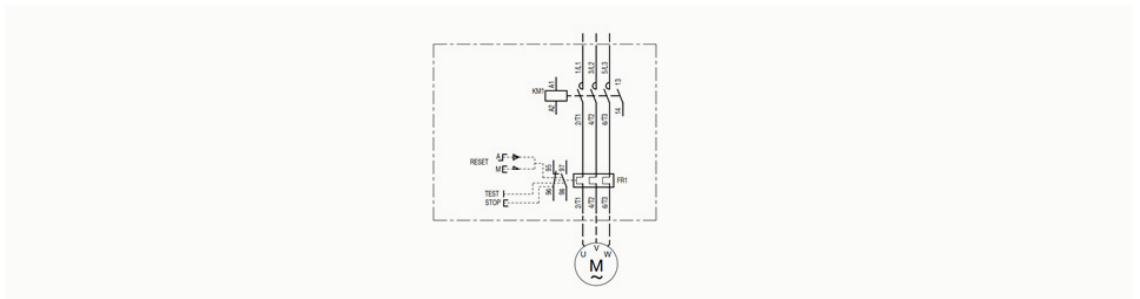

Star-delta starting

If it is necessary to restrict the starting current of a motor because of supply limitations, the star-delta (Y/Δ) method can be employed. For instance, when a motor wound for is started with winding Y connected, this method will reduce the starting current to about 30% of the current reached with DOL, and the starting torque will be reduced to about 25% of its DOL value. However, before using this method, it must be determined whether the reduced motor torque is sufficient to accelerate the load over the motor's speed range.

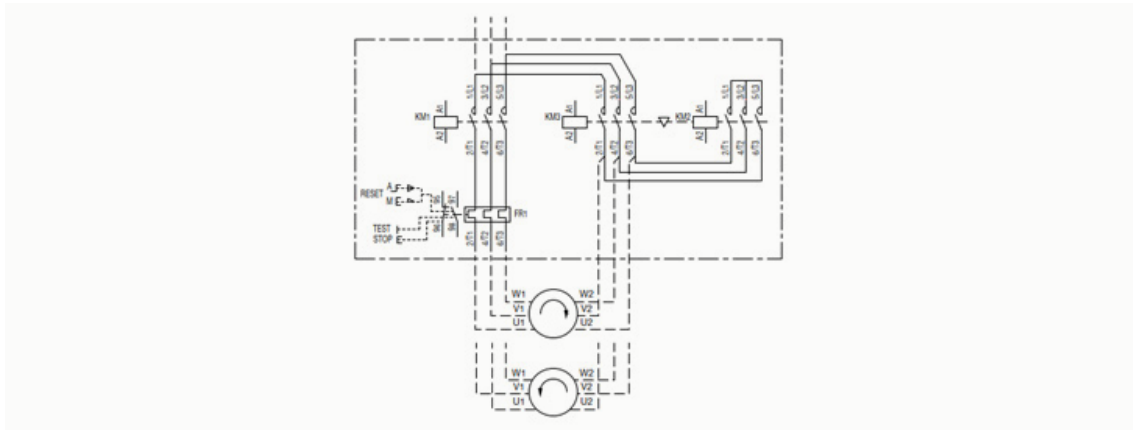

INSTALLATION AND COMMISSIONING FOR OVERLOAD RELAYS









Connection cross sections

Overload relays are typically available with screw terminals.









Connection cross sections for screw connection technology

The following tables show the permissible conductor cross-sections for the main connections







THERMAL OVERLOAD RELAYS TF42:

									
≤ 20A	2T1 4T2 6T3	M4 1.1 ... 2.5 Nm 9 ... 13 lb.in	ø 6.5 mm	Pozidriv No. 2	1/2 × 1.5 ... 4.0 mm ² *	1/2 × 0.75 ... 4.0 mm ²	1/2 × 0.75 ... 4.0 mm ²	1/2 × 0.75 ... 4.0 mm ²	12 mm
	95-96 97-98	M3 1.0 ... 1.2 Nm 9 ... 11 lb.in			1/2 × 1.5 ... 4.0 mm ² *	1/2 × 0.75 ... 1.0 mm ² *	1/2 × 1.0 ... 2.5 mm ² *	1 × 0.75 ... 2.5 mm ²	2 × 0.75 ... 1.5 mm ²
≥ 20A	2T1 4T2 6T3	M4 2.5 ... 2.7 Nm 22 lb.in	ø 6.5 mm	Pozidriv No. 2	1/2 × 1.5 ... 2.5 mm ² *	1/2 × 2.5 ... 4.0 mm ²	1 × 1.5 ... 6 mm ²	1 × 1.5 ... 6.0 mm ²	12 mm
	95-96 97-98	M3 1.0 ... 1.2 Nm 9 ... 11 lb.in			1/2 × 0.75 ... 4.0 mm ²	1/2 × 0.75 ... 1.0 mm ² *	1/2 × 1.0 ... 2.5 mm ² *	1 × 0.75 ... 2.5 mm ²	2 × 0.75 ... 1.5 mm ²









THERMAL OVERLOAD RELAYS TF65:

								
2T1 4T2 6T3	M6 4.0 ... 4.5 Nm 35 ... 40 lb.in	ø 6.5 mm	Pozidriv No. 2	1 × 2.5 ... 35 mm ²	1 × 2.5 ... 35 mm ²	1 × 2.5 ... 35 mm ²	1 × 2.5 ... 35 mm ²	17 mm
				1/2 × 2.5 ... 16 mm ²	1/2 × 2.5 ... 16 mm ²	1/2 × 2.5 ... 10 mm ²	1/2 × 2.5 ... 10 mm ²	
95-96 97-98	M3 1.0 ... 1.2 Nm 9 ... 11 lb.in	ø 5.5 mm	Pozidriv No. 2	1/2 × 0.75 ... 4.0 mm ²	1 × 0.75 ... 2.5 mm ²	1 × 0.75 ... 2.5 mm ²	1 × 0.75 ... 2.5 mm ²	9 mm
				1/2 × 0.75 ... 4.0 mm ²	1/2 × 0.75 ... 2.5 mm ²	1 × 0.75 ... 2.5 mm ²	2 × 0.75 ... 1.5 mm ²	









THERMAL OVERLOAD RELAYS TF96:

							
2T1 4T2 6T	M8 6 ... 9.0 Nm 53 ... 80 lb.in	ø 6.5 mm	Hexagon	1 × 6 ... 50 mm ²	1 × 2.5 ... 35 mm ²	1 × 6 ... 50 mm ²	1 × 6 ... 50 mm ²
				1/2 × 6 ... 35 mm ²	1/2 × 2.5 ... 16 mm ²	1/2 × 6 ... 35 mm ²	1/2 × 6 ... 16 mm ²
95-96 97-98	M3 1.0 ... 1.2 Nm 9 ... 11 lb.in	ø 5.5 mm	Pozidriv No. 2	1/2 × 0.75 ... 4.0 mm ²	1/2 × 0.75 ... 1.0 mm ² *	1 × 0.75 ... 2.5 mm ²	1 × 0.75 ... 2.5 mm ²
				1/2 × 0.75 ... 4.0 mm ²	1/2 × 1.0 ... 2.5 mm ² *	1 × 0.75 ... 2.5 mm ²	2 × 0.75 ... 1.5 mm ²









THERMAL OVERLOAD RELAYS TF140DU:

									
2T1	M8								
4T2	6 ... 10.0 Nm	4 mm	Hexagon	1 × 16 ... 70 mm ²	1 × 16 ... 70 mm ²	1 × 16 ... 70 mm ²	1 × 16 ... 70 mm ²	25 mm	
6T3	53 ... 88 lb.in								
95 - 96	M3								
97 - 98	1.0 ... 1.2 Nm 9 ... 12 lb.in	ø 5.5 mm	Pozidriv No. 2	1/2 × 0.75 ... 4.0 mm ²	1/2 × 0.75 ... 4.0 mm ²	1 × 0.75 ... 2.5 mm ²	1 × 0.75 ... 2.5 mm ²	9 mm	









TERMAL OVERLOAD RELAYS TA2000DU:

								
2T1	M8							
4T2	25 Nm	-	-	1 × 25 ... 120 mm ²	1 × 25 ... 200 mm ²	-	-	ø ≥ 10 mm
6T3	53 ... 88 lb.in				1/2 × AWG 4 ... 0000			L ≤ 28 mm-
95 - 96	M3.5							
97 - 98	0.8 ... 1.3 Nm 12 lb.in	ø 5.5 mm	Pozidriv No. 1	1/2 × 0.75 ... 4.0 mm ²	1/2 × 1.0 ... 2.5 mm ² * 1/2 × AWG 18 ... 14	1 × 0.75 ... 2.5 mm ²	9 mm	-









ELECTRONIC OVERLOAD RELAYS EF19:

								
2T1	M3.5							
4T2	1.1 ... 1.5 Nm	ø 5.5 mm		1/2 × 1.0 ... 4.0 mm ²	1/2 × 0.75 ... 2.5 mm ²	1/2 × 0.75 ... 2.5 mm ²	1/2 × 0.75 ... 2.5 mm ²	9 mm
6T3	7 ... 13 lb.in		Pozidriv No. 2	1/2 × AWG 16 ... 10	1/2 × AWG 16 ... 10			
95 - 96	M3.5							
97 - 98	1.0 ... 1.2 Nm 7 ... 11 lb.in	ø 5.5 mm		1/2 × 1.0 ... 4.0 mm ²	1/2 × 0.75 ... 2.5 mm ²	1/2 × 0.75 ... 2.5 mm ²	1/2 × 0.75 ... 2.5 mm ²	9 mm

THERMAL OVERLOAD RELAYS EF45:









								
2T1	M5							
4T2	2.3 ... 2.6 Nm	ø 5.5 mm		1/2 × 2.5 ... 16 mm ²	1/2 × 2.5 ... 10 mm ²	1 × 6 ... 50 mm ²	1/2 × 2.5 ... 10 mm ²	13 mm
6T	20 ... 22 lb.in		Pozidriv No. 2	1/2 × AWG 14 ... 6	1/2 × AWG 14 ... 6	1/2 × 6 ... 35 mm ²		
95 - 96	M3.5							
97 - 98	0.8 ... 1.2 Nm 7 ... 11 lb.in	ø 5.5 mm		1/2 × 1.0 ... 4.0 mm ²	1/2 × 0.75 ... 2.5 mm ²	1/2 × 0.75 ... 2.5 mm ²	1/2 × 0.75 ... 2.5 mm ²	9 mm

THERMAL OVERLOAD RELAYS EF65:









								
2T1	M8							
4T2	4.0 Nm	ø 5.5 mm		1/2 × 4.0 ... 35 mm ²	1/2 × 4.0 ... 35 mm ²	1 × 4 ... 35 mm ²	1 × 6 ... 50 mm ²	20 mm
6T3	35 lb.in		Pozidriv No. 2		1/2 × AWG 10 ... 2	1/2 × 2 ... 35 mm ²	1/2 × 6 ... 16 mm ²	
95 - 96	M3.5							
97 - 98	0.8 ... 1.2 Nm 7 ... 11 lb.in	ø 5.5 mm		1/2 × 1.0 ... 4.0 mm ²	1/2 × 0.75 ... 2.5 mm ² * 1/2 × AWG 18 ... 10	1 × 0.75 ... 2.5 mm ²	1 × 0.75 ... 2.5 mm ² 2 × 0.75 ... 1.5 mm ²	9 mm

INSTALLATION AND COMMISSIONING FOR OVERLOAD RELAYS









THERMAL OVERLOAD RELAYS EF96:

								
2T1	M8							
4T2	6.0 Nm	4 mm	Hexagon	1 × 16 ... 70 mm ²	11 × 6 ... 70 mm ²	1 × 6 ... 50 mm ²	1 × 6 ... 50 mm ²	20 mm
6T3	55 lb.in			2 × 6 ... 35 mm ²	2 × 6 ... 35 mm ²	2 × 6 ... 35 mm ²	2 × 6 ... 35 mm ²	
	M3.5							
95 - 96	0.8 ... 1.2 Nm	ø 5.5 mm	Pozidriv No. 2	1/2 × 0.75 ... 4.0 mm ²	1/2 × 1.0 ... 2.5 mm ² *	1/2 × 0.75 ... 2.5 mm ²	1/2 × 0.75 ... 2.5 mm ²	9 mm
97 - 98	7 ... 11 lb.in				1/2 × AWG 18 ... 12			









ELECTRONIC OVERLOAD RELAYS EF146:

								
2T1	M8							
4T2	8.0 Nm	-	Hexagon	1 × 10 ... 95 mm ²	1 × 10 ... 70 mm ²	1 × 10 ... 70 mm ²	1 × 10 ... 70 mm ²	20 mm
6T3	70 lb.in			2 × 10 ... 35 mm ²	2 × 10 ... 35 mm ²	2 × 10 ... 35 mm ²	2 × 10 ... 35 mm ²	
	M3.5							
95 - 96	0.8 ... 1.2 Nm	ø 5.5 mm	Pozidriv No. 2	1/2 × 0.75 ... 4.0 mm ²	1/2 × 1.0 ... 2.5 mm ² *	1/2 × 0.75 ... 2.5 mm ²	1/2 × 0.75 ... 2.5 mm ²	9 mm
97 - 98	7 ... 11 lb.in				1/2 × AWG 18 ... 12			

ELECTRONIC OVERLOAD RELAYS EF370:

								
2T1	M10							
4T2	28 Nm	-	-	1 × 50 ... 240 mm ²	1 × 50 ... 240 mm ²	-	-	ø ≥ 10 mm
6T3	247 lb.in			2 × 50 ... 150 mm ²	2 × 50 ... 150 mm ²	-	-	L ≤ 32 mm-
	M3.5							
95 - 96	0.8 ... 1.2 Nm	ø 5.5 mm	Pozidriv No. 2	1/2 × 1.0 ... 4.0 mm ²	1/2 × 1.0 ... 2.5 mm ² *	1 × 0.75 ... 2.5 mm ²	9 mm	-
97 - 98	7 ... 11 lb.in				1/2 × AWG 18 ... 12			

ELECTRONIC OVERLOAD RELAYS EF460 AND EF750:

								
2T1	M3.5							
4T2	0.8 ... 1.2 Nm	ø 5.5 mm	Pozidriv No. 2	1/2 × 1.0 ... 4.0 mm ²	1/2 × 0.75 ... 2.5 mm ²	1/2 × 0.75 ... 2.5 mm ²	1/2 × 0.75 ... 2.5 mm ²	9 mm
6T	7 ... 11 lb.in				1/2 × AWG 18 ... 10			

Motor current setting procedure

Set the current on the scale of the overload relay current setting with the help of a screwdriver. Use a screwdriver on the overload relays scale to set the actual motor current (setting current).

Motor current setting

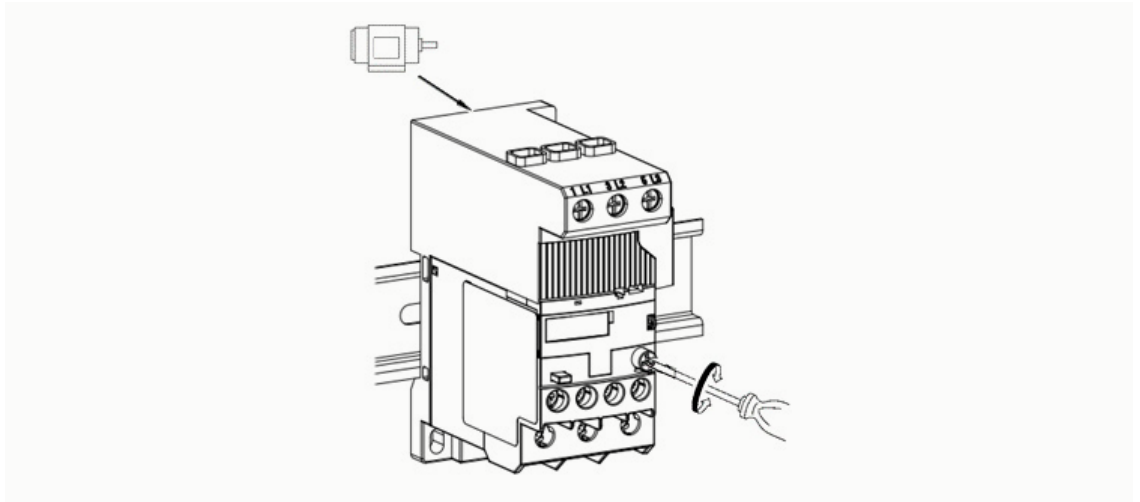

Note on the tripping class or tripping characteristic of the electronic overload relay: Select the tripping class so that the motor is thermally protected even when the rotor is blocked. The motor, the cables and the contactor must be designed for the selected tripping class.

Overload trip test

Self test: The overload relays should be set to trip at a rated motor current > 80% of the lowest set current range. To ensure this, we recommend the following four steps:

- a) Set the rated current I_e of the motor.
 - b) Let the motor run for at least 5 minutes.
 - c) Now reduce the rated current set ~ 20%
 - d) Now wait until the tripping time (note tripping class) has elapsed and the overload relay reacts.
- After a positive self-test, reset the overload relay to the actual motor current.

Overload trip test

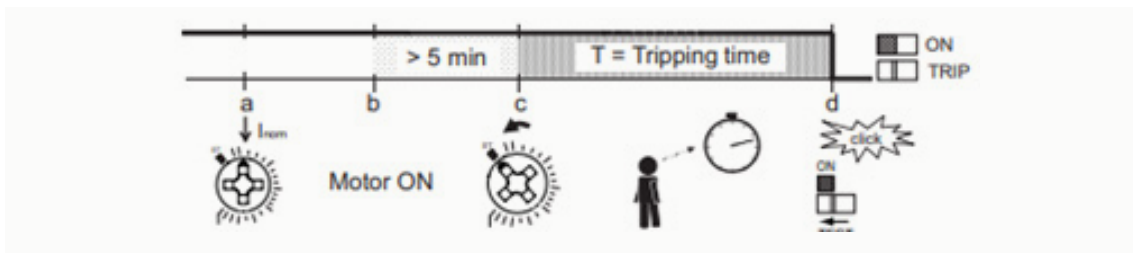

Trip class	10E	20E	30E
Tripping time	<100 s	<180 s	<250 s

INSTALLATION AND COMMISSIONING FOR OVERLOAD RELAYS

Restart after tripping

The thermal overload relays have thermal memory. After tripping due to an overload, the relay requires a certain period for the bimetal strips to cool down (also applicable for the electronic overload relays, a motor model is contained in it). This period is so-called recovery time. The relay can only be reset once it has cooled down. The recovery time depends on the characteristic tripping curves and the level of the tripping current. After tripping due to overload, the recovery time allows the load to cool down.

ATEX Operating instructions

Operating instructions for overload relays in potentially explosive areas can be accessed from the ABB Download Center <https://library.abb.com>.

- Categories > ABB Products > Low Voltage Products and Systems > Control Product > Contactors > Electronic Overload relays
- Categories > ABB Products > Low Voltage Products and Systems > Control Product > Contactors > Thermal Overload relays

Installation instructions

Installation instructions for overload relays can be accessed from the ABB Download Center <https://library.abb.com>.

- Categories > ABB Products > Low Voltage Products and Systems > Control Product > Contactors > Electronic Overload relays
- Categories > ABB Products > Low Voltage Products and Systems > Control Product > Contactors > Thermal Overload relays

2D drawings and 3D models

2D and 3D drawings for overload relays and accessories can be accessed from the ABB CAD download portal (<http://abb-control-products.partcommunity.com/portal/portal/abb-control-products>).

NOTES

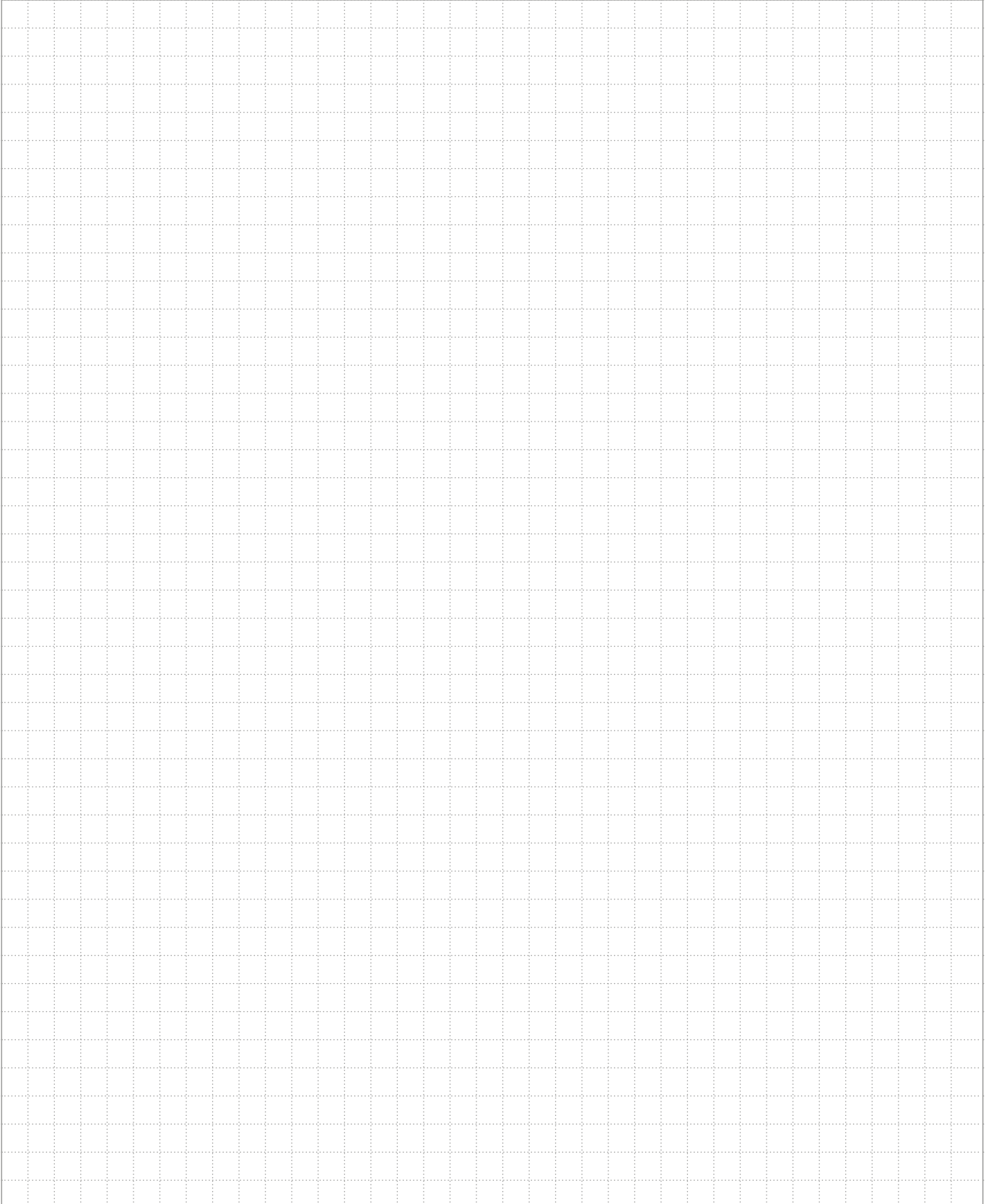

10

The background features a subtle grid pattern that becomes more pronounced towards the right side. A color gradient is present, transitioning from a light, almost white color at the top to a vibrant red at the bottom left and a deep blue at the bottom right.

GLOSSARY

AC	Alternating current
Active power	The power consumed by the motor that is converted into mechanical action
Ambient temperature	The temperature of water, air or surrounding medium where the equipment is used or stored
DC	Direct current
Delta connection	The connection type of a motor where the windings are connected in a delta configuration
Efficiency	The ratio between mechanical output and electrical input – the percentage given indicates how effective the motor is at converting electrical energy to mechanical energy
Frequency	The number of periodic cycles per unit of time
FLA	Full load amps (sometimes also FLC= full load current), rated current at rated load and rated voltage: this is the amount of current (amps) the motor will draw from the electrical system when producing its rated output horsepower
IE3	Premium-efficiency class for single-speed motors according to IEC 60034-30
IE4	Super Premium-efficiency class for single-speed motors according to IEC 60034-30 version 2014
IEC	International Electrotechnical Commission, which is part of the International Organization for Standardization (ISO)
Inertia	A measure of a body's resistance to a change in velocity whether the body is moving at a constant speed or is at rest – the velocity can be rotational or linear
Inrush peak	A short, high-current transient occurring during the first milliseconds when the motor is started
LED	Light-emitting diode
Load torque	The braking torque on the motor shaft caused by the load – if the braking torque is equal or nearly equal to the rated motor torque it can be defined as high load torque
MEPS	Minimum Energy Performance Standard: local regulation specifying the minimum required energy performance for energy-using products – in Europe the EU MEPS for direct-on-line motors is IE3
MMS	Manual motor starter
N-end	The end that is normally the non-drive end of an electrical motor
NEMA	The National Electrical Manufacturers Association (USA)
Network	Several nodes connected to each other with some type of communication medium – a network can be of single link type or multiple link type
Noise	Unwanted disturbances in a communication medium that tend to obscure the data content
Operational voltage	The voltage that is fed to the motor, usually 3-phase
Overload relay	A device used to avoid overheating of the motor. Can be of electronic or thermal type
PLC	Programmable Logic Controller
Power factor	Power factor (PF) is the ratio of working power, measured in kilowatts (kW), to apparent power, measured in kilovolt amperes (kVA)
Rated current	The rated current is the current drawn by a fully-loaded motor at its specified nominal speed
Reactive power	The power consumed by the motor which is used for the magnetization of the motor
RMS	Root Mean Square: the RMS value of an AC supply is the steady DC equivalent, which would convert electrical energy to thermal energy at the same rate in a given resistance
SCCR	Short-circuit Current Ratings, see also Chapter: 7.1.6 Selecting the right Short-circuit Current Ratings (SCCR) level for your UL application
Tripping Class	The tripping class defines the starting time at a specific current before tripping occurs; different classes exist, for example, 10, 20, 30, etc. where class 30 allows the longest starting time
U_e	Rated operation voltage, see also Chapter: 2.2.1 Rated operational voltage (U _e)



ABB AG – STOTZ-KONTAKT

Electrification Business

Low Voltage Products and Systems

Eppelheimer Str. 82

DE-69123 Heidelberg

Phone: +49 (0) 6221 7 01-0

Fax: +49 (0) 6221 7 01-13 25

E-Mail: info.desto@de.abb.com

**You can find the address of your local
sales organization on the ABB
homepage**



abb.com/lowvoltage

We reserve the right to make technical changes or modify the contents of this document without prior notice. ABB does not accept any responsibility whatsoever for potential errors or possible lack of information in this document.

We reserve all rights in this document and in the subject matter and illustrations contained therein. Any reproduction, disclosure to third parties or utilization of its contents – in whole or in parts – is forbidden without prior written consent of ABB.

Copyright© 2026 ABB - All rights reserved