

XV-303/XV-313 multi-touch display



Company information

All brand and product names are trademarks or registered trademarks of their respective owners.

Service

For service and support, please contact your local sales team.

Contact info. Eaton.com/contact

Service page: Eaton.com/aftersales

Original Operating Instructions

is the German-language edition of this document

Publication date

04/2026, Edition 1.02

Copyright

© 2025 by Eaton Industries GmbH, 53105 Bonn

All rights, including those of translation, reserved.

No part of this manual may be reproduced, stored in a retrieval system, or transmitted in any form or by any means, whether electronic, mechanical, photocopying, micro-filming, recording, or otherwise, without the prior written permission of EATON.

Subject to alteration.



DANGER!

Hazardous electrical voltage!

Before starting with the installation

- Installation requires qualified electrician
 - Disconnect the power supply of the device.
 - Secure against retriggering
 - Verify isolation from the supply
 - Ground and short-circuit
 - Cover or enclose any neighboring live parts.
 - Follow the engineering instructions (IL) of the device concerned.
 - Only suitably qualified personnel in accordance with EN 50110-1/-2 (VDE 0105 part 100) may work on this device/system.
 - Before installation and before touching the device ensure that you are free of electrostatic charge.
 - The functional earth (FE) must be connected to the protective earth (PE) or to the equipotential bonding. The system installer is responsible for implementing this connection.
 - Connecting cables and signal lines should be installed so that inductive or capacitive interference does not impair the automation functions.
 - Install automation devices and related operating elements in such a way that they are well protected against unintentional operation.
 - Suitable safety hardware and software measures should be implemented for the I/O interface so that a line or wire breakage on the signal side does not result in undefined states in the automation devices.
 - Deviations of the mains voltage from the nominal value must not exceed the tolerance limits given in the specifications, otherwise this may result in malfunction and hazardous states.
 - Emergency-Stop devices complying with IEC/EN 60204-1 must be effective in all operating modes of the automation devices. Unlatching the emergency stop devices must not result in an automatic restart.
 - Built-in devices for enclosures or cabinets must only be run and operated in an installed state;
- desktop devices and portable devices only when the housing is closed.
- Measures should be taken to ensure the proper restarting of programs interrupted after a voltage dip or outage. This should not result in dangerous operating states even for a short time. If necessary, emergency stop devices should be implemented.
 - Wherever faults in the automation system may cause damage to persons or property, external measures must be implemented to ensure a safe operating state in the event of a fault or malfunction (for example, by means of separate limit switches, mechanical interlocks, etc.).

Table of Contents

	XV-303/XV-313 multi-touch display Manual	1
	Company information	2
	Before starting with the installation	3
	Table of Contents	4
0.1	About this documentation	8
0.1.1	List of revisions	8
0.1.2	Target group	9
0.1.3	Legal disclaimer	10
0.1.4	Device designations and abbreviations	10
0.1.5	Writing conventions	11
0.1.5.1	Warning labels	11
0.1.5.2	Additional information for use	12
1.	Description	13
1.1	Function	13
1.1.1	Features	13
1.1.2	Options	13
1.1.3	Notes	14
1.1.3.1	XN300	14
1.2	Use as intended	14
1.3	Device models - versions and part nos.	15
1.3.1	Basic features	15
1.3.2	Device variants	15
1.3.3	Optional features	15
1.4	Operating and indication elements	18
1.5	Interfaces to peripheral devices	19
1.6	What the different parts of the part number mean	20
1.7	Accessory devices	21
1.8	Nameplate	22
1.9	Support	22
1.10	Conditions for Underwriters Laboratories Inc. (UL) listing	23
1.11	Marine approvals	24

2.	Safety regulations	25
2.1	Basics	25
2.2	Mandatory requirements, personnel requirements	25
2.2.1	Occupational safety	25
2.2.2	Personnel qualifications	25
2.2.3	Device documentation	25
2.2.4	Installation, maintenance, and disposal	26
2.2.5	Prerequisites for proper operation	26
2.3	Device-specific hazards	27
3.	Installation	33
3.1	Prerequisites for the location of use	33
3.1.1	Installation position	33
3.1.1.1	Temperatures	34
3.1.1.2	Aeration and de-aeration	35
3.1.1.3	Criteria for the Installation position	36
3.1.2	Technical conditions for acceptance by Underwriters Laboratories Inc. (UL)	37
3.1.3	Conditions for marine approval	38
3.1.3.1	Radio interference suppression filter for the 24-V-DC-supply	38
3.2	Unpacking and checking the equipment supplied	40
3.3	Mounting	41
3.3.1	Fixing and sealing	41
3.3.2	Front mounting XV-303	42
3.3.3	Rear (wall) mounting XV-313	44
3.4	Preparing the device for operation	46
3.4.1	Functional earthing XV-303/XV-313 multi-touch display	48
3.4.2	Power supply - electrical connection	49
4.	Commissioning	51
4.1	Initial commissioning	51
4.2	Running the XV300	52
4.2.1	Display Characteristics of TFT Displays (Image Retention / Ghosting)	52
4.2.2	Notes on Visualization Project Design	52

5.	External connections	53
5.1	Layout of interfaces	54
5.2	SD card	55
5.3	USB interfaces	56
5.3.1	USB host	56
5.3.2	USB device	56
5.4	Ethernet 1, Ethernet 2	57
5.5	Serial interfaces for communication with PLCs or devices	58
5.5.1	RS-232 COM1	58
5.5.1.1	Wiring topic	58
5.5.2	RS-485 COM2	59
5.6	CAN1 interface for the CANopen protocol, J1939 protocol, etc.	61
6.	Faults	63
7.	Maintenance	64
7.1	Cleaning and maintenance	64
7.1.1	Capacitive multi-touch technology (PCT)	64
7.1.2	Battery	64
7.2	Repairs	65
7.3	Storage, transport and disposal	65
7.3.1	Storage and transport	65
7.3.2	Disposal	67
	Appendix	68
A.1	Technical data	69
A.1.1	Data sheets	69
A.1.2	Dimension and weight specifications	71
A.1.2.1	XV-303 Front mounting	71
A.1.2.2	XV-313 Rear (panel) mounting	74
A.1.2.3	Mounting surrounds for rear (panel) mounting	77
A.1.3	General data	78
A.1.4	Port and interface specifications	80
A.1.5	Information on the power supply	81
A.1.6	Approvals and declarations	82
A.2	Further usage information	84

Alphabetical index85

0.1 About this documentation

This Manual contains all the information you will need in order to use the XV-303/XV-313 multi-touch display safely and effectively.

The Manual XV-303/XV-313 multi-touch display manual is considered an integral part of the devices and must always be readily available in the device's close proximity so that users have access to it.

This Manual describes all of the devices' lifecycle stages: transportation, installation, commissioning, operation, maintenance, storage, and disposal.

It assumes you have electrical engineering knowledge and skills.

It does not, however, go over the corresponding operating system or application software.

Make sure to always use the latest documentation for your device.



Manual XV-303/XV-313 multi-touch display

MN048031EN

The latest version of this documentation, as well as additional references, is available for download on the Internet. → Section "Further usage information", page 84



[Eaton.com/documentation](https://www.eaton.com/documentation)

Please send any comments, recommendations, or suggestions regarding this document to: DocumentationEGBonn@eaton.com

0.1.1 List of revisions

The following significant amendments have been introduced since previous issues:

Publication date	Keyword	New	Modification
04/2024	New edition	✓	
03/2025	Change date of copyright and editorial date to 2025 for US market		✓
04/2026	Image Retention / Ghosting Notice	✓	

0.1 About this documentation

0.1.2 Target group

This Manual is intended for electricians and electrical engineers, as well as for the people who will be in charge of performing the electrical installation and people who will be using the XV-303/XV-313 multi-touch display as an operating and monitoring device or as an integrated operating and control device in their own applications.



CAUTION

Installation requires qualified electrician



Follow the safety instructions for the XV300!

The section on safety instructions must be read and understood by everyone who will be working with the XV-303/XV-313 multi-touch display before the actual work is performed HMI-PLC.



WARNING

Incomplete operator manual copies

Working with individual pages taken out from the operator manual may lead to bodily injury and property damage due to missing safety information.

- ▶ Always work with the latest and full document.

0.1.3 Legal disclaimer

All the information in this manual has been prepared to the best of our knowledge and in accordance with the state of the art. However, this does not exclude the possibility of there being errors or inaccuracies. We assume no liability for the correctness and completeness of this information. In particular, this information does not guarantee any particular properties.

Do not use the XV-303/XV-313 multi-touch display before reading and understanding this manual.

It is assumed that the user of this manual is thoroughly familiar with the information found in the manuals for incorporating the XV-303/XV-313 multi-touch display into automation processes.

Hazards posed by the XV300 cannot be eliminated if the safety instructions are not observed – especially if the XV-303/XV-313 multi-touch display is commissioned and maintained by unqualified personnel and/or the XV300 is used improperly. Eaton assumes no liability for any damages resulting from cases such as these.

0.1.4 Device designations and abbreviations

The following general terms are used throughout this manual:

Short designation	Explanation
XV300 multi-touch display	Product family with function code
HMI-PLC	Family
XV300	Used to refer to all the devices in the product family
XV-303	Used to refer to all front mounting devices as a group
XV-313	Used to refer to all rear (panel) mounting devices as a group



For the exact designation for your XV-303/XV-313 multi-touch display, please refer to the → "Nameplate", page 22.

0.1 About this documentation

0.1.5 Writing conventions

Tab. 1: Format conventions used throughout this manual

Award	Description
Bold text	Used for all graphical user interface elements
Monospaced	Used for all elements at the file level
Font format code	
<code>Text</code>	Used for the button labels
<code>Menu path\submenu\...item</code>	Path information for software windows and menu pages
<code>Menu/command</code>	Used for commands found in the menu bar's menus
<code><name></code>	Angle brackets are used to indicate variable values that you must replace with your own values

0.1.5.1 Warning labels

Risk of personal injury warning.

	DANGER Warns of hazardous situations that result in serious injury or death.
--	--

	WARNING Warns of the possibility of hazardous situations that could result in serious injury or even death.
---	---

	DANGER! Dangerous Electrical Voltage!
---	---

	CAUTION Warns of the possibility of hazardous situations that can cause injury.
---	---

Property damage warning

NOTICE Warns about the possibility of material damage.
--

1. Description

1.1 Function

XV-303/XV-313 multi-touch display can be used as operating and monitoring devices or with featuring PLC functionalities as operating and control devices.

HMI-PLC feature an industrial high-resolution display with capacitive multi-touch technology. This, combined with a highly precise and intuitive gesture-based user interface, enables operators to start working right away. Their unmatched system performance with a powerful graphics processing unit powers a state-of-the-art user interface.

With their compact and sleek design – featuring a heavy-duty, flat, anti-glare glass panel – XV300 multi-touch display are ideal for industrial applications in harsh environments.

1.1.1 Features

- Sleek design with capacitive multi-touch technology (PCT)
- Heavy-duty, anti-glare tempered glass; easy to clean
- Requires very little space; can also be used in portrait mode
- XV-303 model for front mounting and XV-313 model for rear (panel) mounting
- Display sizes 7.0" and 10.1" with a 1024 x 600 Pixel resolution, Display size 15.6" with a 1366 x 768 Pixel resolution
- Powerful CPU: 800 MHz ARM Cortex-A9
- 1 GB internal memory and 128 kB non-volatile data memory
- The unit's memory can be expanded with SD cards (accessories)
SD card slot for SD / SDHC memory cards
- Linux Operating System
- Comprehensive basic configuration with integrated interfaces

1.1.2 Options

- Additional integrated Ethernet interface
- Integrated Control (PLC)

1. Description

1.2 Use as intended

1.1.3 Notes

1.1.3.1 XN300



The ultra-compact XN300 modular slice card I/O system, which features a plug-in connection system, complements the XV series with application-oriented functions that are ideal for optimized system solutions.

1.2 Use as intended

XV-303/XV-313 multi-touch display are primarily intended for use in machine and system building applications.

They are intended exclusively for monitoring, operating, and controlling machines and systems.

Any other use must be discussed and agreed upon with the manufacturer in advance.

The XV300 multi-touch display are approved for use in closed spaces.



Bid

The HMI-PLC must be used only in locations for which the XV300 is approved. Make sure to read and follow the information and labels on the nameplate for the HMI-PLC, as well as section Approvals and declarations in the appendix.



Prohibited uses, actions, etc.

It is strictly prohibited to use the device in order to implement safety-relevant functions (in the sense of personal and machine protection).

1.3 Device models - versions and part nos.

1.3.1 Basic features

All XV are equipped with:

- the operating system Linux
- an industrial capacitive multitouch display (PCT)
- a SD/SDHC memory card slot.

Every HMI-PLC comes with the following integrated interfaces as standard:

- One Ethernet port (10/100 Mbit/s) for use as a communication or field bus interface
- One USB 2.0 host port for memory and other accessories, full power (500 mA)
- One USB device 2.0,
- One standard RS-232 (COM1) port for communicating with PLCs or devices
- One standard RS-485 (COM2) port for communicating with PLCs or devices
- One standard CAN interface for the CANopen protocol, J1939 protocol

1.3.2 Device variants

One of the main differences between the various device models is the specific mounting method that must be used when installing the devices in an enclosure.

- Front mounting, in which the device is inserted into the enclosure from the front
- Rear mounting, which provides a flush alignment with the enclosure's surface

1.3.3 Optional features

The following individual options are available in order to ensure that the unit will best meet the needs of the application at hand:

- Three widescreen display sizes: 7.0", 10.1" or 15.6" widescreen
- Device bundles with visualization software and/or control software licenses.

Additional integrated interface

- Second Ethernet port (10/100 Mbit/s) for use as a communication interface

Device models with PLC functionality

1. Description

1.3 Device models - versions and part nos.

Tab. 2: Enclosure versions for front mounting
Front with plastic bezel



Fig. 1: XV-303-70-..



Fig. 3: XV-303-10-..



Fig. 5: XV-303-15-..

Service side with optional interfaces



Fig. 2: XV303-70-C00-A00-2B



Fig. 4: XV-303-10-B00-A00-2B



Fig. 6: XV-303-15-C00-A00-2B

1. Description

1.3 Device models - versions and part nos.

Two versions are available for rear (wall) installation for different sheet thicknesses of the installation panel

Version

A00	Standard version, sheet thickness of the installation panel $d = 1.5 \text{ mm } (0.059") \pm 0.1 \text{ mm } (0.004")$
A11	Sheet thickness of the installation panel $d = 2 \text{ mm } (0.08") \pm 0.1 \text{ mm } (0.004")$

Tab. 3: Enclosure versions for rear (panel) mounting
Front side with aluminum mounting frame



Fig. 7: XV-313-70-..



Fig. 9: XV-313-10-..

Service side with optional interfaces



Fig. 8: XV-313-70-B00-A00-2C

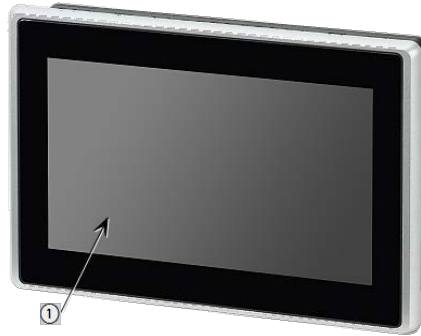

Fig. 10: XV-313-10-C00-A00-2C

1. Description

1.4 Operating and indication elements

1.4 Operating and indication elements



Front XV-303

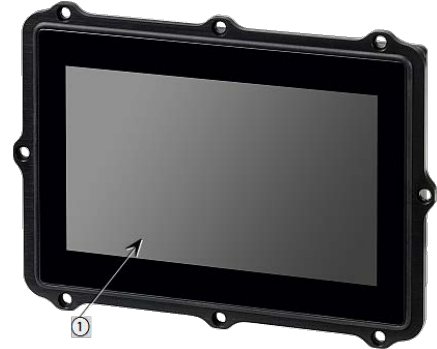

Front XV-313



Service side with optional interfaces XV-303



Service side with optional interfaces XV-313

① Display, touch sensor

Display of HMI device
 Detects when the controls shown on the display are being actuated.
 Operation based on touch gestures.

② SD card slot

Slot for SD card

③ CTRL button

The specific function depends on the software being used

1.5 Interfaces to peripheral devices

The interfaces featured by your XV-303/XV-313 multi-touch display will depend on the XV version selected and cannot be modified.

The nameplate will indicate which specific interfaces are included with the unit.

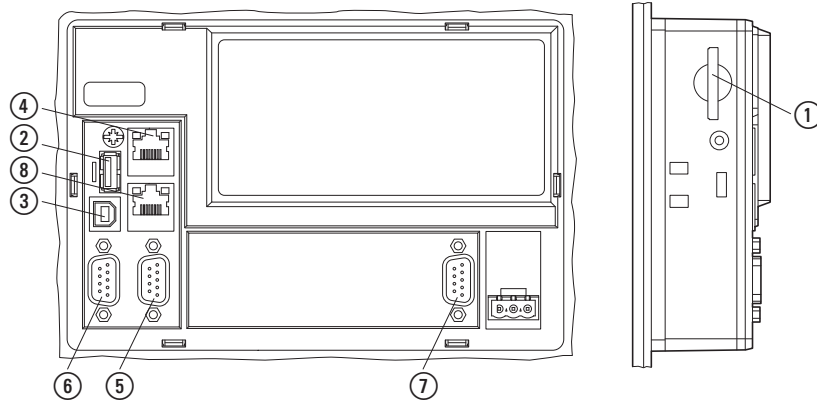

Fig. 11: Interfaces

Basic interfaces (found on all XV300)

Interface	Version
① SD card slot	SDSC or SDHC conforming to the SDA 2.0 specification
② USB host	USB 2.0, not galvanically isolated, plug type A, Full power (500 mA)
③ USB device	USB 2.0, not galvanically isolated, plug type B
④ Ethernet 1	RJ-45 socket, 8-pole, 2 LEDs (CAT5e/6), LAN1, 10/100 Mbps
⑤ RS-485	SUB-D plug 9-pole, not galvanically isolated, UNC nuts for interlocking
⑥ RS-232	SUB-D plug 9-pole, not galvanically isolated, UNC nuts for interlocking
⑦ CAN	SUB-D plug 9-pole, not galvanically isolated, UNC nuts for interlocking

Optional interfaces

⑧ Ethernet 2	RJ-45 socket, 8-pole, 2 LEDs (CAT5e/6), LAN1, 10/100 Mbps
--------------	---

1. Description

1.6 What the different parts of the part number mean

1.6 What the different parts of the part number mean

The part number includes information that specifies the version and model of the specific device being used.

The nameplate on your XV300 multi-touch display will show the corresponding part number.

Tab. 4: Part number

XV	-	3..	-	..	-	...	-	...	-	..
		Type		Display size		Interfaces		Version		Visualization software

Tab. 5: Type

3..	
303	Front mounting
313	Rear (panel) mounting

Tab. 6: Display size

..	
70	7.0" screen diagonal
10	10.1" screen diagonal
15	15.6" screen diagonal

Tab. 7: Interfaces

..	
B00	Base (1 slot for 1 SD-card, built-in interfaces: 1 × Ethernet 100/10, 1 × RS232, 1 × CAN, 2 × USB host, 1 × USB device, 1 × RS-485, 1 × RS-232, 1 × CAN)
C00	Base + 2. Ethernet

Tab. 8: Version

...	
A00	Standard version, Type XV-313 sheet thickness of the installation panel $d = 1.5 \text{ mm } (0.059") \pm 0.1 \text{ mm } (0.004")$
A11	Type XV-313 sheet thickness of the installation panel $d = 2 \text{ mm } (0.08") \pm 0.1 \text{ mm } (0.004")$

1. Description

1.7 Accessory devices

Tab. 9: Bundles with visualization software

..	
2 B	Linux, runtime license for GALILEO visualization software
2C	Linux, integrated PLC function, runtime licenses for GALILEO visualization software and XSoft CoDeSys 3

XV300 devices are available with various bundle options that include visualization software licenses and/or control software licenses. For more information, or to order, contact your supplier or use the Eaton online catalog.

Enter "XV300" into the search box and the catalog will take you directly to the corresponding product group in the Automation, Control and visualization section.

 Eaton.com/ecat

1.7 Accessory devices

A variety of accessories are available for XV300 multi-touch displays.

- SD card
- Accessories

NOTICE

Only use original accessories.



Order accessories through your supplier or through the EATON online catalog Eaton.eu/ecat

Example:

article no.	Catalog Number
181638	MEMORY-SD-A2-S SD memory card with min. 1 GB
181637	ACCESSORIES-TP-10-KG brackets for XV-303-70-../XV-303-10-.. or XV-303-15-..

1. Description

1.8 Nameplate

1.8 Nameplate

The device has a nameplate on rear.

This nameplate includes the following information:

- Manufacturer
- Part number
- Part-No.
- EPAS code (digital nameplate)
- Version
- Date of manufacture
- Required power supply
- Serial-No.
- Type approval and certification marks and information
- Layout of ports/interfaces and controls



Fig. 12: Example for a nameplate

1.9 Support

To get fast and effective support, make sure to always provide Customer Service with the following information from the nameplate:

- Part-No.
- Serial-No

1.10 Conditions for Underwriters Laboratories Inc. (UL) listing

1.10 Conditions for Underwriters Laboratories Inc. (UL) listing



The following conditions must be met in order for the certification of UL 61010-2-201 as per XV to apply:

Ambient temperature 0°C to 50°C

Mounting height up to 2000 m

Overvoltage category II

Pollution Degree 2

Permissible voltage range 20%/+25% of rated operating voltage

Type rating

Use in type 4X or type 12 enclosures, use indoors only, at dry locations only

Maximum relative humidity of 95% for temperatures of up to 50 °C, derated linearly to a relative humidity of 50% at 40 °C.

Suitable power supply for class III (SELV or PELV)

The devices must be installed in a suitable fire protection enclosure that provides protection against the spread of fire.

The torque used to tighten the screw terminals on the plug-in connection for the supply voltage must not exceed 0.6 ... 0.8 Nm (5 ... 7 lb-in).

Required only for XV-303/XV-313 multi-touch display SmartWire-DT units with a connection.

The supply voltage U_{Aux} of the SmartWire-DT master interface must be externally protected against overcurrent and short circuit by means of:

- Miniature circuit-breakers 24V_{DC}, rated operational current 2 A, tripping characteristic Z
- Or a 2 A fuse

1. Description

1.11 Marine approvals

1.11 Marine approvals

Type approval received



XV300 multi-touch display 7.0" und 10.1" have been granted the required shipping classification by Det Norsk Veritas / Germanischer Lloyd (DNV GL)

- DNVGL-CG-0339 type approval, November 2015 edition, "Environmental test specification for electrical, electronic and programmable equipment and systems"
Certificate No.: TAA00000NC

Location classes

Temperature B - Ambient temperature: 0°C to +55°C

Humidity B - Relative humidity up to 100 % at all relevant temperatures.

Vibration A - Bulkheads, beams, deck, bridge, acceleration amplitude: 0.7 g

EMC A* - All locations except bridge and open deck
B* - All locations (including bridge and open deck)

Input Required protection according to DNV-GL Rules shall be provided upon installation on board

* Filters / Ferrites maybe required to fulfil. See installation restrictions

Installation restrictions

1. Install and commission referring to manuals.
2. Screened communication cables improve EMC behavior
3. PE connection of communication cables improve EMC behavior (e.g. earth-connection kit: EATON ZB4-102-KS1)

Location class	interface	Installation
EMC B	Power supply	Place noise filter
EMC A		No additional installations

 **Please refer to the following as well** → Section "Conditions for marine approval", page 38

2. Safety regulations

2.1 Basics

The device has been designed according to the state of the art and all generally accepted safety rules and standards. However, this alone cannot eliminate all potential hazards, which is why it is necessary for you to be aware of all hazards and residual risks.

Do not run the device unless it is in perfect technical condition. Make sure to always operate it as specified in this document and for the intended purpose.



Follow the safety instructions for the XV300!

The section on safety instructions must be read and understood by everyone who will be working with the XV-303/XV-313 multi-touch display before the actual work is performed HMI-PLC.

NOTICE

Pay attention to the hazard severity levels used throughout this documentation whenever a hazard is indicated. The hazard symbol and signal word used and the corresponding text will provide information regarding the specific hazard and how to avoid or prevent it.

2.2 Mandatory requirements, personnel requirements

2.2.1 Occupational safety

All generally accepted occupational health and safety rules and standards (internal and national) must be complied with, as must be all applicable laws and regulations in the relevant country.

2.2.2 Personnel qualifications

The personnel responsible for installation, operation, maintenance, and repairs must have the necessary qualifications for the work they will be performing. They must be appropriately trained and/or briefed and be informed of all hazards and risks associated with the device.

2.2.3 Device documentation

This manual is considered an integral part of the XV300 and must always be readily available in the device's close proximity so that users have access to it.

2. Safety regulations

2.2 Mandatory requirements, personnel requirements

Make sure that every person who will be working with the XV300, regardless of the lifecycle stage involved, has read and understood the relevant parts of the documentation for the XV300.

Additional parts of the documentation and information for the XV300, including the installation instructions, can be found at the Eaton Download Center - Documentation and at the product pages on the Internet

 [Eaton.com/documentation](https://www.eaton.com/documentation)

 [Eaton.com/XV300](https://www.eaton.com/XV300)



WARNING

Incomplete operator manual copies

Working with individual pages taken out from the operator manual may lead to bodily injury and property damage due to missing safety information.

▶ Always work with the latest and full document.

2.2.4 Installation, maintenance, and disposal

Make sure that the XV300 is connected, installed, serviced, and disposed of professionally and in line with all relevant standards and safety rules.



CAUTION

Installation requires qualified electrician



Important!

Dispose of recyclables as required by your local recycling regulations.

HMI-PLC XV300 no longer being used must be professionally disposed of as per local standards or returned to the manufacturer or relevant sales department.

2.2.5 Prerequisites for proper operation

In order for the device to be able to meet the contractually stipulated terms, the following must be observed:

- Only qualified personnel should be allowed to work with the XV300.
- The personnel working with the XV300 must have read the manual and must follow all the instructions in it.
- The required ambient conditions must be met.
- Maintenance work must be carried out correctly.



Make sure to read the → "Legal disclaimer", page 10.

2. Safety regulations

2.3 Device-specific hazards

We assume no liability for damages, consequential damages, and/or accidents caused by the following:

- Failure to follow any applicable occupational health and safety rules, standards, and/or regulations
- Device failures or function disturbances
- Improper use and/or handling
- Not following the instructions or observing the information in the documentation for the XV300
- Alterations, changes, and repairs to the XV300

2.3 Device-specific hazards



EXPLOSION HAZARD

Death, serious injury, and property damage may occur if the device is being used in a potentially explosive (classified) location and, during operation, an electrical plug-in connection is disconnected or the device is exposed to dangerous impacts or other types of dangerous mechanical shock.

- ▶ Use the device in the following environments only:
Non-hazardous (non-explosive) areas
Zone 22 hazardous areas (as defined in the ATEX Directive)
- ▶ Make sure that the device is not exposed to dangerous impacts and other types of dangerous mechanical shock.
- ▶ Do not operate the device in hazardous (classified) locations unless it is mounted correctly.
- ▶ De-energize the device before disconnecting plug connections.

2. Safety regulations

2.3 Device-specific hazards



EXPLOSION HAZARD

LITHIUM BATTERY

The lithium battery inside the XV-303/XV-313 multi-touch display may explode if handled incorrectly.

- ▶ Dispose of the XV300 unit professionally.



CAUTION

DESTRUCTION

The XV-303/XV-313 multi-touch display should only be opened by the manufacturer or by an authorized center. Operate the XV300 until only with the enclosure fully closed and sealed.



CAUTION

ELECTROSTATIC DISCHARGE

Do not touch components (e.g., connector pins) that are electrostatic-sensitive.

- ▶ Discharge any static electricity from your body before touching the HMI-PLC (e.g., by touching an earthed metal object).

Electrostatic discharges may damage or ruin assembly parts.

Because of this, it is necessary to take precautions whenever handling the cards.

Please refer to the guidelines for electrostatic-sensitive components for more information (ESD guidelines).



CAUTION

INTERFERENCES

The values specified in the technical data, as well as the device's electromagnetic compatibility (EMC), cannot be guaranteed if the following are used: unsuitable cables, improperly assembled and terminated cables, and/or wiring that does not conform to the applicable standards.

Only use cables assembled and terminated by professionals.

The cables being used must be assembled and terminated as required by the port/interface description in this document.

When wiring the XV300 multi-touch display, follow all instructions regarding how to wire the corresponding port/interface.

All general Directives and standards must be complied with.



CAUTION

INTERFERENCES

2. Safety regulations

2.3 Device-specific hazards

Screw all plug-in connections or lock them into place in order to improve screening.

Signal cables must not be routed in the same cable duct with power cables.

Before putting the system into operation, check all cable connections to make sure that everything has been wired properly.

Make sure that all voltages and signals have the required values as specified in the technical data.



CAUTION

SAFELY DIVERTING ELECTRICAL INTERFERENCE CURRENTS

HMI-PLC The XV300 must be connected to a central earth point with a conductor that is as short and has as low a resistance as possible.

- Ground connection characteristics:

Wire cross-sectional area $\geq 1.5 \text{ mm}^2$, length $\leq 350 \text{ mm}$

The XV-303/XV-313 multi-touch display needs to be connected to the conductive structure in, e.g., the control panel using the central earth point (earthing screw). This method of earthing is mandatory required for proper function.



DANGER

STRAY CURRENTS

Large equalizing currents between the functional earthing system and the ground system of different devices may result in fire or in malfunctions due to signal interference.

- ▶ If necessary, route an equipotential bonding conductor, with a cross-sectional area that is several times larger than that of the cable shielding, parallel to the cable.



CAUTION

NON-GALVANICALLY-ISOLATED INTERFACES

The XV300 may be damaged by potential differences.

- ▶ The GND terminals of all bus modules must be connected.
- ▶ Do not connect the connector to the XV300 or disconnect it without first de-energizing the system.



CAUTION

DATA LOSS

Avoid over-writing to the device's internal memory and/or an SD card and/or a USB memory, reasons:

2. Safety regulations

2.3 Device-specific hazards

- The number of write cycles of the device's internal memory, SD cards and USB memory is limited.
- If there is a voltage drop while a write operation is in progress, data loss is highly likely to occur.



CAUTION DATA LOSS

- ▶ Insert or remove the SD card only when the XV-303/XV-313 multi-touch display is de-energized.
- ▶ Before switching off the device, make sure that there are no programs writing to the SD card.



CAUTION SHORT-CIRCUIT HAZARD

If the XV300 multi-touch display is or has been exposed to environmental fluctuations (ambient temperature, air humidity), condensation may form on or inside. As long as this condensation is present, there will be a short-circuit hazard.

Do not switch on the XV300 multi-touch display when it has condensation in or on it.

If the XV300 multi-touch display has condensation in or on it, or if the panel has been exposed to environmental fluctuations, let the panel settle into the existing ambient temperature before switching it on.

Do not expose the XV300 multi-touch display to direct thermal radiation from heating appliances.



CAUTION UV LIGHT

Plastics will become brittle when exposed to UV light. This artificial aging will reduce the XV-303/XV-313 multi-touch display unit's lifespan. Protect the XV300 unit from direct sunlight and other sources of UV radiation.

2. Safety regulations

2.3 Device-specific hazards



CAUTION **POINTY, SHARP OBJECTS AND CORROSIVE LIQUIDS**

When cleaning the XV-303/XV-313 multi-touch display:

- Do not use any pointy or sharp objects (e.g., knives).
- Do not use aggressive or abrasive cleaning products or solvents.

Make sure that no liquids get into the XV-303/XV-313 multi-touch display unit (short-circuit hazard) and that the XV-303/XV-313 multi-touch display unit is not damaged in any way.



CAUTION **INSTALLATION CUT-OUT**

The mounting cutout must be located in a position that will not defeat the purpose of stabilizing webs or other reinforcing elements in the control panel. If necessary, reinforcing elements must be installed/added.

An IP65, Nema 4x and Nema 12 degrees of protection will only be ensured if there is sufficient stiffness, the device is properly mounted using the original fixing material, and the gasket has a proper seat

- Minimum sheet thickness of control panel panel where the device will be flush mounted:

$$2 \text{ mm (0.08")} \leq d \leq 5 \text{ mm (0.2")}$$



CAUTION

When using commercially available peripheral devices (e.g., with the USB port), it is important to keep in mind that their EMC interference immunity parameters may render them unsuitable for use in industrial environments.

The USB ports (USB host and USB device) on the XV300 multi-touch display are intended exclusively for maintenance work.



WARNING

The device should only be run with safety extra-low voltage (functional extra-low voltage with protective separation).

The power transformer must conform to the relevant standards.

2. Safety regulations

2.3 Device-specific hazards



CAUTION

FORCES ON THE ETHERNET INTERFACE

Communications may be affected, and the connection's mechanical components may be damaged, if the Ethernet interface is subjected to strong vibrations or the RJ45 plug-in connection is subjected to pulling.

- Protect the RJ45 plug-in connection from strong vibrations.
- Protect the RJ45 plug-in connection from tensile forces at the socket.



WARNING

XV-303/XV-313 multi-touch display units are products designed for use in industrial environments as defined in ICE/EN 6100-6-4. These products can cause radio interference in domestic environments. In this case, the party operating the products must implement appropriate radio interference suppression measures.



CAUTION

Installation requires qualified electrician



3. Installation

3.1 Prerequisites for the location of use

The XV300 must be used exclusively in locations for which HMI-PLC has been approved/certified.

A 24 VDC supply voltage must be ensured as per the specifications.

 **See also** Label on the → "Nameplate", page 22

as well as the specifications in the appendix → Section "Technical data", page 69

3.1.1 Installation position

The following must be taken into account when selecting the installation position:

- If you will be using the HMI-PLC in a hazardous (explosive) location, make sure it is not exposed to any dangerous impacts or other types of dangerous mechanical shock.
- The controls and connectors on the XV device's service side must remain accessible even after the device has been installed.



The SD card slot is located on the side of the XV300.
Make sure to take the space required to remove the SD card into account.

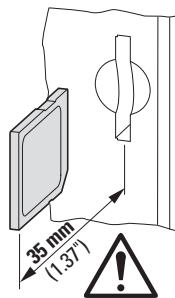

Fig. 13: Space required to remove the SD card

3. Installation

3.1 Prerequisites for the location of use

3.1.1.1 Temperatures

Make sure that the HMI-PLC does not overheat.

Do not expose the HMI-PLC to direct sunlight or other sources of heat.

The minimum clearance to components emitting heat, such as transformers under heavy loads, is 15 cm.



**CAUTION
UV LIGHT**

Plastics will become brittle when exposed to UV light. This artificial aging will reduce the XV-303/XV-313 multi-touch display unit's life-span. Protect the XV300 unit from direct sunlight and other sources of UV radiation.

The environmental ambient conditions for operation must not exceed the specified values:

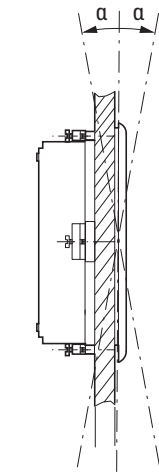
Ambient climatic conditions	
Air pressure (in operation)	795 - 1080 hPa Max. 2000 m above sea level
Temperature	<p>Operation $\pm 0 - +50$ °C (+32 - +122 °F)</p> <p>Mounting position XV-303-70-..., XV-303-10-..., XV-313 $\alpha \leq \pm 45^\circ$, $T \leq 50$ °C (122 °F)</p>  <p>XV-303-15-.. $\alpha \leq \pm 10^\circ$, $T \leq 50$ °C (122 °F) $\alpha \leq \pm 45^\circ$, $T \leq 45$ °C (113 °F) Inclination from vertical: $\alpha \leq \pm 45^\circ$ at operating temperature $\leq 45^\circ$ C (113°F) possible (if using natural convection)</p>
Storage / Transport	$-20 - + 60$ °C (-4 - +140 °F)
Humidity	Relative humidity 10 - 95 %
Condensation	non-condensing

3. Installation

3.1 Prerequisites for the location of use

3.1.1.2 Aeration and de-aeration

- Do not block the ventilation openings when mounting the device: They are designed to allow air to circulate in order to cool the HMI-PLC.
- The device uses natural convection-based passive cooling, i.e., it does not use fans.

Ventilation diagram



Fig. 14: Cooling air circulation

Clear Zone

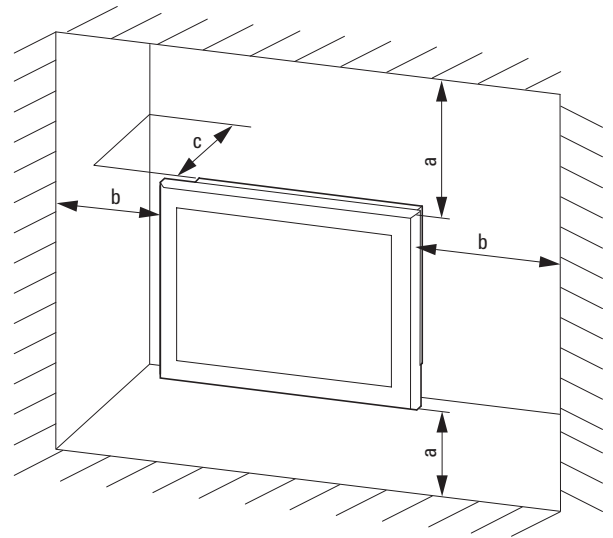

Fig. 15: Mounting distance

- Make sure that there will be enough volume for air changes inside the control panel, etc.
The specified clearance around the XV-303/XV-313 multi-touch display is: $a, b, c \geq 30 \text{ mm (1.18")}$
- If you will be installing the XV-303/XV-313 multi-touch display in complex systems together with other assemblies, you must ensure that there will be enough air circulation in order to prevent overheating.
Ambient temperature with natural convection: $\vartheta 0^{\circ}\text{C (32}^{\circ}\text{F)} \leq T \leq 50^{\circ}\text{C (122}^{\circ}\text{F)}$
The panel builder is responsible for the temperature rise calculation. Eaton will provide heat dissipation data for the XV-303/XV-313 multi-touch display as necessary for design verification in accordance with IEC EN 61439.
- An inclination angle α greater than 10° is only permissible for certain XV-303-15-.. device models and only at a reduced max. ambient temperature of 45°C .

3. Installation

3.1 Prerequisites for the location of use

3.1.1.3 Criteria for the Installation position

The XV300 are intended to be flush mounted in control cabinets, control panels, or control consoles.

- The XV-303/XV-313 multi-touch display can be installed in landscape or portrait mode.

If you are using your XV-303/XV-313 multi-touch display unit with an SD card, do not install it with the SD slot facing downwards, as the SD card may fall out otherwise.

- If no forced ventilation is being used, the device must not be mounted at an angle α exceeding $\pm \alpha \leq 45^\circ$ relative to its fully vertical position.

An inclination angle α greater than 10° is only permissible for certain XV-303-15-.. device models and only at a reduced max. ambient temperature of 45°C .

- The enclosure material must be thick enough

XV-303-70-.., XV-303-10-.., XV-303-15-..

For front mounting: $2\text{ mm } (0.08") \leq d \leq 5\text{ mm } (0.2")$,

XV-313-70-.., XV-313-10-..

For rear (panel) mounting: XV-313-..-...-A00-.. $d = 1.5\text{ mm } (0.059") \pm 0.1\text{ mm } (0.004")$,

XV-313-..-...-A11-.. $d = 2\text{ mm } (0.08") \pm 0.1\text{ mm } (0.004")$

Flatness $\square \leq 0.5\text{ mm } (0.02")$ at the mounting cutout with $\nabla R_z \leq 120$; IP 65 \rightarrow DIN ISO 2768-2 (K)

- Recommended mounting cutout

for front mounting

XV-303-10-..: $e = 183\text{ mm } \pm 1 (7.20" \pm 0.04)$, $f = 122\text{ mm } \pm 1 (4.80" \pm 0.04")$

XV-303-70-..: $e = 255.5\text{ mm } \pm 1 (10.06" \pm 0.04)$, $f = 160.5\text{ mm } \pm 1 (6.32" \pm 0.04)$,

XV-303-15-..: $e = 387\text{ mm } \pm 1 (15.24" \pm 0.04)$, $f = 238.5\text{ mm } \pm 1\text{ mm } (9.39" \pm 0.04)$

for rear (panel) mounting

XV-313-70-..: $e = 182.7\text{ mm } \pm 0.1 (7.193" \pm 0.004)$, $f = 126.8\text{ mm } \pm 0.1 (4.992" \pm 0.004)$

XV-313-10-..: $e = 255.7\text{ mm } \pm 0.1 (10.07" \pm 0.004)$, $f = 165.8\text{ mm } \pm 0.1 (6.528" \pm 0.004)$

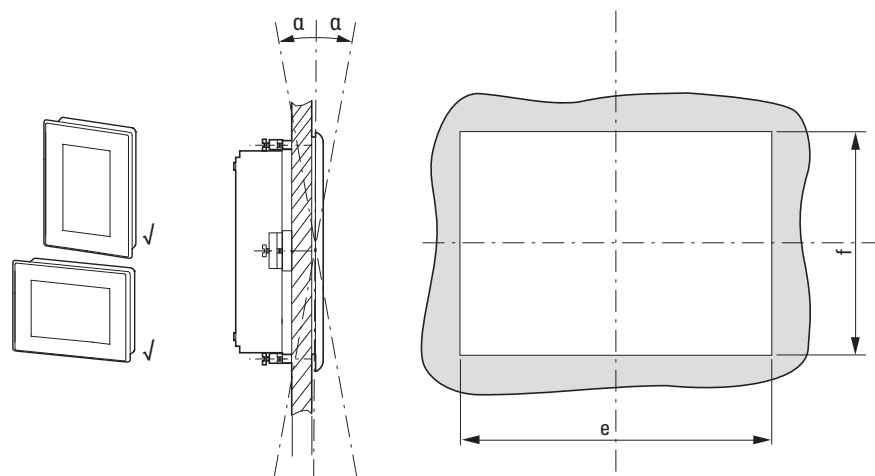

Fig. 16: Mounting position

3. Installation

3.1 Prerequisites for the location of use

3.1.2 Technical conditions for acceptance by Underwriters Laboratories Inc. (UL)



The following conditions must be met in order for the certification of UL 61010-2-201 as per XV to apply:

Ambient temperature 0°C to 50°C

Mounting height up to 2000 m

Oversvoltage category II

Pollution Degree 2

Permissible voltage range 20%/+25% of rated operating voltage

Type rating

Use in type 4X or type 12 enclosures, use indoors only, at dry locations only

Maximum relative humidity of 95% for temperatures of up to 50 °C, derated linearly to a relative humidity of 50% at 40 °C.

Suitable power supply for class III (SELV or PELV)

The devices must be installed in a suitable fire protection enclosure that provides protection against the spread of fire.

The torque used to tighten the screw terminals on the plug-in connection for the supply voltage must not exceed 0.6 ... 0.8 Nm (5 ... 7 lb-in).

3. Installation

3.1 Prerequisites for the location of use

3.1.3 Conditions for marine approval



The following DNV GL rules for shipping classification in accordance with DNVGL-CG-0339 type approvals must be observed:

1. Complete and proper installation and commissioning in accordance with DNV GL rules and Eaton requirements and specifications.
2. Installation of radio interference suppression filters for the 24 V DC supply.

3.1.3.1 Radio interference suppression filter for the 24-V-DC-supply

Additional interference filters must be installed for the power supply in order to adhere to the EMC B provisions.

- ▶ Integrate a radio interference suppression filter into the wiring.

Depending on the output, the following filters can be used:

- XT-FIL-1 radio interference suppression filter for 24 V DC supply up to 2.2 A (Eaton article no. 285316)

or

- XT-FIL-2 radio interference suppression filter for 24 V DC supply up to 12 A (Eaton article no. 118980)

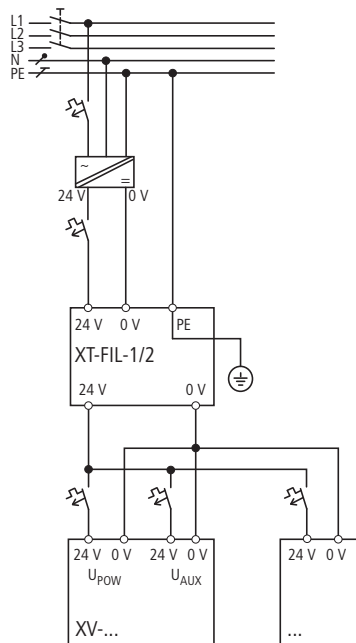

Fig. 17: Engineering example for integration of radio interference suppression filters

Earthing is ensured either by using

- the filter's integrated contact fields onto a grounded metal plate

or using

3. Installation

3.1 Prerequisites for the location of use

- a separate line to the filer's PE connection.

Depending on the current consumption or configuration, several filters may be used as well.

3. Installation

3.2 Unpacking and checking the equipment supplied

3.2 Unpacking and checking the equipment supplied

- ▶ Check the HMI-PLC's packaging for transit damage.
- ▶ Carefully remove the packaging in order to avoid damaging the device.
- ▶ Check the package contents for visible transit damage.
- ▶ Use the information in Installation instructions IL048022ZU or IL048023ZU to make sure that the contents are complete.



Keep the original packaging so that you will be able to use it in the future if you need to transport or ship the HMI-PLC. Make sure to also keep the documents enclosed with the device and/or to give them to the end customer.

The package for the XV-303/XV-313 multi-touch display comes with:

Tab. 10: Std. pack

Unit	Description
1 x	orXV-303XV-313
1 x	Plug connector MSTB 2.5/3-ST-5.08
1 x	Installation instructions IL048022ZU or IL048023ZU
6 x / 10 x /12 x	Holding bracket with set screw Internal hexagon M 4 x 25 DIN 914 galvanized 6 x for XV-303-10-..., 10 x for XV-303-70-..., or 12 x for XV-303-15-..

The XV-303/XV-313 multi-touch display is sturdily built, but the components inside it are sensitive to excessively strong vibrations and/or mechanical shock.

Accordingly, make sure to protect the XV-303/XV-313 multi-touch display from mechanical loads that exceed the scope of the unit's intended use.

The XV300 should only be transported in its original packaging after being packed properly.

3.3 Mounting

NOTICE

Arrange for a professional technician to mount the device.



CAUTION
INSTALLATION CUT-OUT

The mounting cutout must be located in a position that will not defeat the purpose of stabilizing webs or other reinforcing elements in the control panel. If necessary, reinforcing elements must be installed/added.

An IP65, Nema 4x and Nema 12 degrees of protection will only be ensured if there is sufficient stiffness, the device is properly mounted using the original fixing material, and the gasket has a proper seat

- Minimum sheet thickness of control panel where the device will be flush mounted:
 $2 \text{ mm (0.08")} \leq d \leq 5 \text{ mm (0.2")}$

3.3.1 Fixing and sealing

- ▶ Make sure to check that the Installation are being met. → page 36
- ▶ Make sure that the mounting cutout has the right size.
- ▶ Check the gasket for damage and make sure it is resting correctly inside the enclosure groove.

Missing parts or damage

If you notice anything wrong, please contact your distributor or Eaton Service +49 (0) 180 5 223822 (de,en)

3. Installation

3.3 Mounting

3.3.2 Front mounting XV-303

Securing the panel with Holding bracket with set screw

List of tools:

- 2.0 m Allen key
- PZ2 Pozidriv screwdriver
- Torque wrench with Newton meter scale

The required holding brackets are included in the right amount as accessories with the HMI-PLC. All the included holding brackets need to be installed!

Together with the gasket, this holding bracket is the main element involved in achieving an IP65 (at front) degree of protection.

The purpose of the holding brackets is to secure the XV300 onto a control panel, etc. To this end, the brackets must be hooked into the enclosure sideways and screwed against the control panel door, etc.

Make sure to position the holding brackets in such a way that they will push against the center of the peripheral gasket.

- ▶ Pre-install the holding brackets using the set screws.

Check that the gasket is in its correct position and pre-install the holding brackets

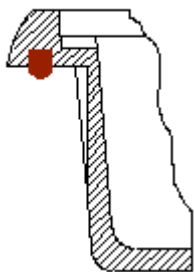

Peripheral gasket in the rim

Sponge rubber round cord, Material NBR/PVC Black, closed outer skin, diameter 3 mm (0.12")

3. Installation

3.3 Mounting

Pre-installing the holding brackets

Screw the set screws Internal hexagon M 4 x 25
DIN 914 galvanized into the holding brackets

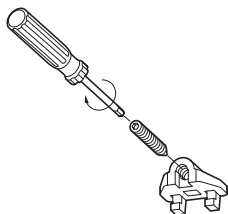

Insert the holding brackets into the enclosure

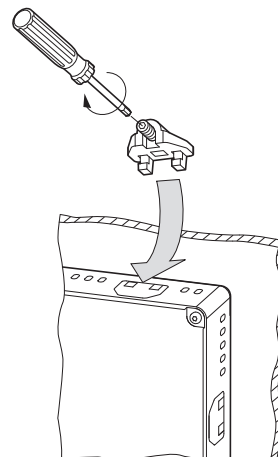

- ▶ 1. Insert the XV-303 into the mounting cutout.
- ▶ 2. Insert a holding bracket into the corresponding enclosure opening and tighten the set screw until it comes into contact with the surface of the control panel, etc.
- ▶ 3. Repeat on the opposite side.
- ▶ 4. Follow steps 3 and 4 to insert the next holding bracket at a 90° angle to the last one you inserted.
- ▶ 5. Repeat steps 3 and 4 until all holding brackets are installed.
- ▶ 6. Check that the device is in its correct, centered position and that the gasket is in contact all around; adjust if necessary.
- ▶ 7. Tighten the set screws in a criss-cross sequence:
with a torque of $\leq 0.1\text{Nm}$ (0.86 lb-in)

3. Installation

3.3 Mounting

3.3.3 Rear (wall) mounting XV-313

This mounting method is intended for use with sheet metal with a wall thickness of (including any coatings on the sheet metal)

Version

- A00 Standard version,
sheet thickness of the installation panel $d = 1.5 \text{ mm } (0.059") \pm 0.1 \text{ mm } (0.004")$
- A11 Sheet thickness of the installation panel $d = 2 \text{ mm } (0.08") \pm 0.1 \text{ mm } (0.004")$

- ▶ Make the mounting cutout.
- ▶ Weld all the M4 x 12 weld studs onto the sheet as shown in the dimensional drawing for mounting

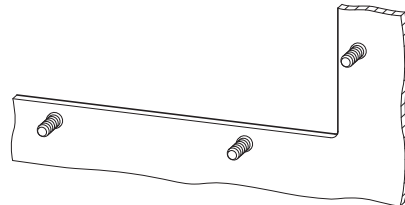

Fig. 18: M4 x 12 weld studs on sheet

Not a true-to-scale template! If necessary, make your own template based on the dimensional drawing for mounting and the right scale.

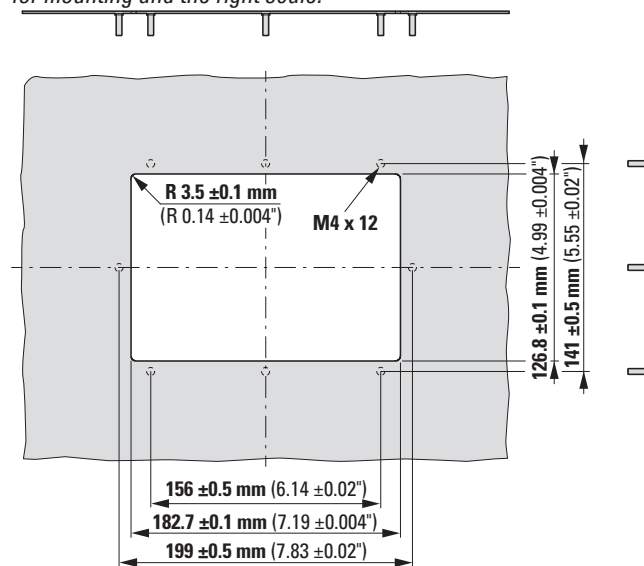

Fig. 19: Dimensional drawing for mounting XV-313-70-..

3. Installation

3.3 Mounting

Not a true-to-scale template! If necessary, make your own template based on the dimensional drawing for mounting and the right scale.

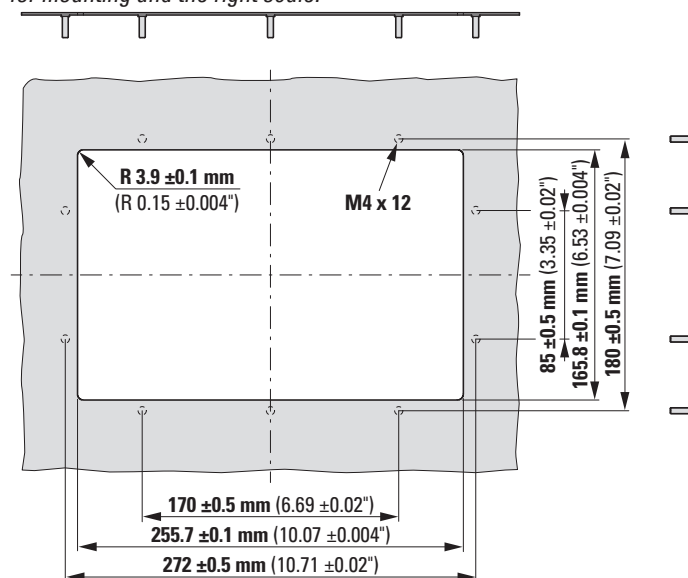

Fig. 20: Dimensional drawing for mounting XV-313-10-..

1. Carefully insert the XV-313 into the mounting cutout from behind.
2. Center the XV-313 in the mounting cutout.
3. Use washers and M4 nuts to fasten the XV-313 to all the weld studs on the sheet in such a way that there is zero clearance

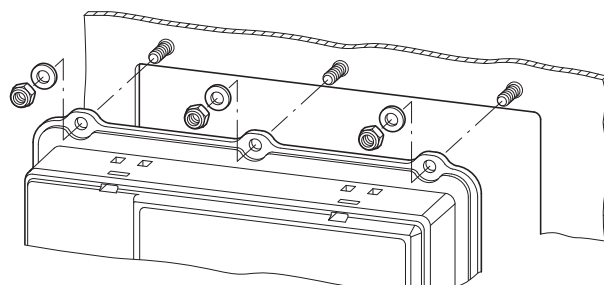

Fig. 21: Mounting XV-313

3. Installation

3.4 Preparing the device for operation

3.4 Preparing the device for operation



CAUTION INTERFERENCES

Screw all plug-in connections or lock them into place in order to improve screening.

Signal cables must not be routed in the same cable duct with power cables.

Before putting the system into operation, check all cable connections to make sure that everything has been wired properly.

Make sure that all voltages and signals have the required values as specified in the technical data.



CAUTION SAFELY DIVERTING ELECTRICAL INTERFERENCE CURRENTS

HMI-PLC The XV300 must be connected to a central earth point with a conductor that is as short and has as low a resistance as possible.

- Ground connection characteristics:

Wire cross-sectional area $\geq 1.5 \text{ mm}^2$, length $\leq 350 \text{ mm}$

The XV-303/XV-313 multi-touch display needs to be connected to the conductive structure in, e.g., the control panel using the central earth point (earthing screw). This method of earthing is mandatory required for proper function.



CAUTION SHORT-CIRCUIT HAZARD

If the XV300 multi-touch display is or has been exposed to environmental fluctuations (ambient temperature, air humidity), condensation may form on or inside. As long as this condensation is present, there will be a short-circuit hazard.

Do not switch on the XV300 multi-touch display when it has condensation in or on it.

If the XV300 multi-touch display has condensation in or on it, or if the panel has been exposed to environmental fluctuations, let the panel settle into the existing ambient temperature before switching it on.

Do not expose the XV300 multi-touch display to direct thermal radiation from heating appliances.

3. Installation

3.4 Preparing the device for operation

Before connecting the power supply



CAUTION

The voltage being applied must meet the requirements for safety extra-low voltages (SELV) set forth in IEC 60950 and the requirements for protected extra-low voltages (PELV) set forth in ICE/UL 61010-2-201.

Pay attention to the polarity.

NOTICE

Arrange for an electrician to install the Plug connector MSTB 2.5/3-ST-5.08 and connect the power supply.

The XV300 multi-touch display has an internal fuse and protection against polarity reversal.

The power supply for the XV300 multi-touch display is not galvanically isolated.

The XV300 multi-touch display requires a rated operating voltage of 24 VDC from an AC-to-DC converter with safe isolation (SELV/PELV).

Power Supply			
rated operating voltage	+ 24 VDC SELV (safety extra low voltage)/PELV (protective extra low voltage)		
permissible Voltage range	Effective: 19.2-30.0 V DC (rated operating voltage -20%/+25%)		
	Absolute with ripple: 18.0-31.2 V DC		
	Battery powered: 18.0-31.2 V DC (rated operating voltage -25%/+30%); 35 V DC for a duration of < 100 ms		
Voltage dips	Ability to accommodate brief voltage dips ≤ 10 ms from rated operating voltage (24 V DC), ≤ 5 ms from undervoltage (19.2 V DC)		
Power consumption	XV-303-10-.., XV-313-10-..	max. 14.4W Current consumption at 24 V DC: 11.9 W for basic device + 2.5 W for USB module	
	XV-303-70-.., XV-313-70-..	max. 18 W Current consumption at 24 V DC: 15.5 W for basic device + 2.5 W for USB module	
	XV-303-15-..	max. 21.6 W Current consumption at 24 V DC: 19.1 W for basic device + 2.5 W for USB module	
fuse	Yes (fuse not accessible)		
Potential isolation	no		
Electrical current	7.0" display	10.1" display	15.6" display
I_e	≤ 0.6 A	≤ 0.75 A	≤ 0.9 A
I_{TH}	1.0 A ² s	1.0 A ² s	1.0 A ² s

3. Installation

3.4 Preparing the device for operation

3.4.1 Functional earthing XV-303/XV-313 multi-touch display



CAUTION

SAFELY DIVERTING ELECTRICAL INTERFERENCE CURRENTS

HMI-PLC The XV300 must be connected to a central earth point with a conductor that is as short and has as low a resistance as possible.

- Ground connection characteristics:

Wire cross-sectional area $\geq 1.5 \text{ mm}^2$, length $\leq 350 \text{ mm}$

The XV-303/XV-313 multi-touch display needs to be connected to the conductive structure in, e.g., the control panel using the central earth point (earthing screw). This method of earthing is mandatory required for proper function.

- ▶ Assemble and terminate the functional earth conductor in advance.
- ▶ Unscrew the earthing screw on the enclosure.
- ▶ Put the earthing connection cable's eyelet in position.
- ▶ Use a torque of 1.3 Nm (11.5 lb-in) to tighten the earthing screw on the enclosure.

Tab. 11: Functional earthing specifications

Functional earthing specifications	
Copper conductor	60° / 70°C
Cross-section	$\geq 1.5 \text{ mm}^2$
	$\leq \text{AWG16}$
Earthing bolt	PZ2, M4 x 8
Ring-cable ferrule for M4	Internal diameter = 4.3 mm
	External diameter $\leq 8 \text{ mm}$
Conductor length	$\leq 350 \text{ mm}$
Tightening torque	1.3 Nm (11.5 lb-in)

Functional earth

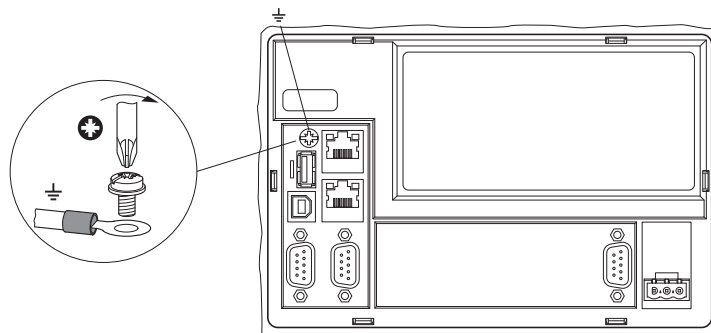

Fig. 22: Screwing the functional earth conductor onto the enclosure

3. Installation

3.4 Preparing the device for operation

3.4.2 Power supply - electrical connection

Tab. 12: Configuration Plug connector MSTB 2.5/3-ST-5.08

signal	Configuration
+	Specifications for connection to supply voltage + 24 VDC SELV (safety extra low voltage)/PELV (protective extra low voltage)
n.c.	not used
-	Supply voltage 0 V

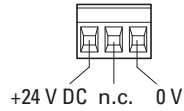

Tab. 13: Specifications for connection to 24 VDC supply voltage

Specifications for connection to 24 VDC supply voltage	
Copper conductor	60° / 70°C
Cross-section	min. 0.75 mm ² / max. 2.5 mm ² (drain wire or conductor) min. AWG18 / max. AWG12
Tightening torque	0.6 ... 0.8 Nm (5 ... 7 lb-in) for the screws on the Plug connector MSTB 2.5/3-ST-5.08
Strip length	7 mm

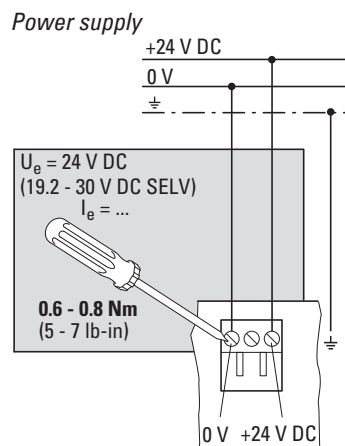

Fig. 23: Connecting the screw terminals on the Plug connector MSTB 2.5/3-ST-5.08

3. Installation

3.4 Preparing the device for operation

Electrical connection

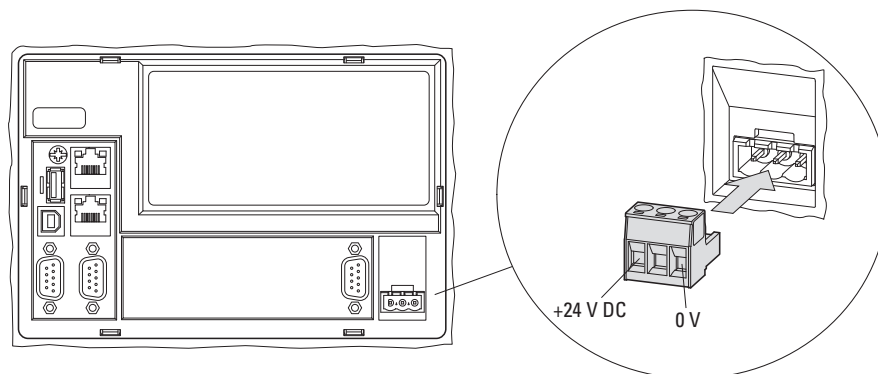

Fig. 24: Power supplied through Plug connector MSTB 2.5/3-ST-5.08

- ▶ Use the Plug connector MSTB 2.5/3-ST-5.08 to terminate the connection cable for the power supply in advance.
- ▶ Plug the pre-assembled plug into the socket on the enclosure.
- ▶ Pay attention to the polarity.
- ▶ Connect the power supply cable to a 24 VDC supply voltage that meets the requirements for safety extra-low voltages (SELV) set forth in IEC 60950 and – in connection with the UL listing – the requirements for a low-voltage source set forth in UL 61010-2-201.

The XV-303/XV-313 multi-touch display is now ready to run on 24 V_{DC}.

4. Commissioning



CAUTION SHORT-CIRCUIT HAZARD

If the XV300 multi-touch display is or has been exposed to environmental fluctuations (ambient temperature, air humidity), condensation may form on or inside. As long as this condensation is present, there will be a short-circuit hazard.

Do not switch on the XV300 multi-touch display when it has condensation in or on it.

If the XV300 multi-touch display has condensation in or on it, or if the panel has been exposed to environmental fluctuations, let the panel settle into the existing ambient temperature before switching it on.

Do not expose the XV300 multi-touch display to direct thermal radiation from heating appliances.

- ▶ Apply a XV300 to the 24 VDC supply voltage unit

The XV300 unit will boot up.



The XV300 multi-touch display does not come with any runtime software for visualization or PLCs installed.

The corresponding software packages can be used to install the required runtime software on the XV300 unit.

4.1 Initial commissioning

Carry out the following steps once:

- ▶ Configure the XV300 unit's system settings as necessary.
- ▶ Install the required software packages.

See also



[System description for embedded Linux](#)

MN050017EN

4. Commissioning

4.2 Running the XV300

4.2 Running the XV300

Once the XV-303/XV-313 multi-touch display has been initially commissioned, it will run whenever it is connected to the supply voltage.

In other words, it does not have to be separately switched on and off.

→ Reducing the level of brightness will increase the display backlight's lifespan.

→ Follow the instructions in the following section if your XV300 until will not boot up and/or if an error message appears: → Section "Faults", page 63

4.2.1 Display Characteristics of TFT Displays (Image Retention / Ghosting)

With touch panels using TFT displays, the long-term display of unchanged, static or high-contrast screen content may lead to so called image retention effects (ghosting).

These effects may cause previously displayed screen content to remain faintly visible after the display content has changed. The intensity and duration of such residual images depends on several factors including the display duration, brightness, contrast, and the type of displayed content.

With very long display times, the effect may persist over an extended period; in rare cases, permanent visibility cannot be completely ruled out.

Generally, existing residual images fade automatically when the display is switched off for a certain time or operated with changing screen content.

Image retention effects are a technology related characteristic of TFT displays and do not indicate a malfunction of the device.

4.2.2 Notes on Visualization Project Design

To reduce or avoid image retention effects, the following measures are recommended when designing the visualization:

- Avoid permanently static screen content
- Change frequently displayed screens at regular intervals, for example by using periodic screen changes or dynamic display elements
- Provide screen savers or inactive screens, preferably with a dark or black display when the backlight is active
- Adjust brightness and contrast according to application requirements
- Automatically switch off the backlight during periods of inactivity, if supported by the target system
- Use blinking or high contrast display elements only in a targeted manner and for limited periods of time

5. External connections

With their ports, Eaton's XV300 multi-touch display make it possible to connect a variety of peripheral devices and components.



DANGER STRAY CURRENTS

Large equalizing currents between the functional earthing system and the ground system of different devices may result in fire or in malfunctions due to signal interference.

- ▶ If necessary, route an equipotential bonding conductor, with a cross-sectional area that is several times larger than that of the cable shielding, parallel to the cable.



CAUTION INTERFERENCES

The values specified in the technical data, as well as the device's electromagnetic compatibility (EMC), cannot be guaranteed if the following are used: unsuitable cables, improperly assembled and terminated cables, and/or wiring that does not conform to the applicable standards.

Only use cables assembled and terminated by professionals.

The cables being used must be assembled and terminated as required by the port/interface description in this document.

When wiring the XV300 multi-touch display, follow all instructions regarding how to wire the corresponding port/interface.

All general Directives and standards must be complied with.

5. External connections

5.1 Layout of interfaces

5.1 Layout of interfaces

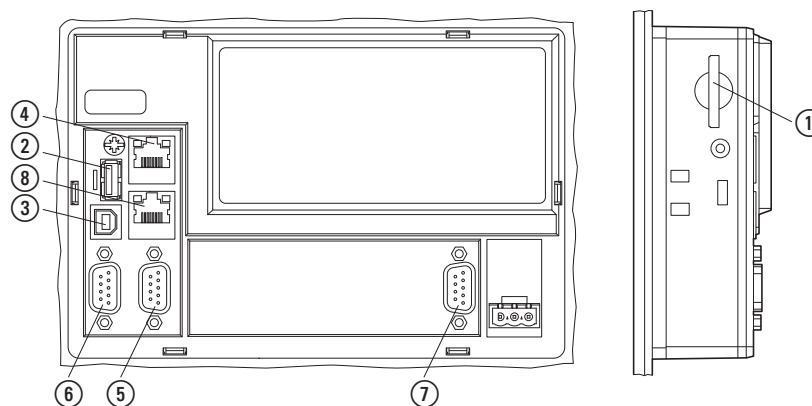

Fig. 25: Basic interfaces on all HMI-PLC units

	Interface	Version
①	SD card slot	SDSC or SDHC conforming to the SDA 2.0 specification
②	USB host	USB 2.0, not galvanically isolated, plug type A, Full power (500 mA)
③	USB device	USB 2.0, not galvanically isolated, plug type B
④	Ethernet 1	RJ-45 socket, 8-pole, 2 LEDs (CAT5e/6), LAN1, 10/100 Mbps
⑤	RS-485	SUB-D plug 9-pole, not galvanically isolated, UNC nuts for interlocking
⑥	RS-232	SUB-D plug 9-pole, not galvanically isolated, UNC nuts for interlocking
⑦	CAN	SUB-D plug 9-pole, not galvanically isolated, UNC nuts for interlocking

Optional

⑧	Ethernet 2	RJ-45 socket, 8-pole, 2 LEDs (CAT5e/6), LAN1, 10/100 Mbps
---	------------	---

5.2 SD card

The slot for the SD card is on the side of the XV300 unit.



**CAUTION
DATA LOSS**

Avoid over-writing to the device's internal memory and/or an SD card and/or a USB memory, reasons:

- The number of write cycles of the device's internal memory, SD cards and USB memory is limited.
- If there is a voltage drop while a write operation is in progress, data loss is highly likely to occur.



**CAUTION
DATA LOSS**

- ▶ Insert or remove the SD card only when the XV-303/XV-313 multi-touch display is de-energized.
- ▶ Before switching off the device, make sure that there are no programs writing to the SD card.

Inserting the SD card



SD cards cannot be inserted the wrong way around.

Do not use force when inserting the card.

- ▶ Push the SD card into the SD card slot until you feel it lock into place.

Removing the SD card

- ▶ Push the SD card into the SD card slot all the way to the stop.
- ▶ Pull the SD card out of the SD card slot.
- ▶ Store the SD card in its case in order to protect it.

5. External connections

5.3 USB interfaces

5.3 USB interfaces

Eaton's XV300 multi-touch display units feature ports that can be used to connect USB peripheral devices supported by the XV300 unit's hardware and operating system.



CAUTION

When using commercially available peripheral devices (e.g., with the USB port), it is important to keep in mind that their EMC interference immunity parameters may render them unsuitable for use in industrial environments.

The USB ports (USB host and USB device) on the XV300 multi-touch display are intended exclusively for maintenance work.



Only use standard USB cables with a shield.

Max. cable length: 5 m.

5.3.1 USB host



Fig. 26: USB 2.0, not galvanically isolated, plug type A, Full power (500 mA)

5.3.2 USB device

The USB device interface supports USB 2.0.



Fig. 27: USB 2.0, not galvanically isolated, plug type B

5.4 Ethernet 1, Ethernet 2

The Ethernet 1 port on the XV300 can be used as a communication interface or as a real-time field bus interface.

The Ethernet 2 port on the XV300 multi-touch display XV-3.3-...-C...-... can only be used as a communication interface without real-time requirements.

The Ethernet controllers support transfer rates of 10 Mbit/s and 100 Mbit/s.

When the green LED lights up, this means that there is a LINK, i.e., that an active network is connected and has been detected.

When the yellow LED flashes, this means that data is being transferred.



Fig. 28: RJ-45 socket, 8-pole, 2 LEDs (CAT5e/6), LAN1, 10/100 Mbps



For the network, use shielded twisted-pair (STP) cables only.



CAUTION
FORCES ON THE ETHERNET INTERFACE

Communications may be affected, and the connection's mechanical components may be damaged, if the Ethernet interface is subjected to strong vibrations or the RJ45 plug-in connection is subjected to pulling.

- Protect the RJ45 plug-in connection from strong vibrations.
- Protect the RJ45 plug-in connection from tensile forces at the socket.

To commission the communication between the XV300 and the device, follow the description for the connected device.

5. External connections

5.5 Serial interfaces for communication with PLCs or devices

5.5 Serial interfaces for communication with PLCs or devices

5.5.1 RS-232 COM1

The RS232-The interface is not electrically isolated.

	CAUTION
	NON-GALVANICALLY-ISOLATED INTERFACES
	The XV300 may be damaged by potential differences.
	<ul style="list-style-type: none"> ▶ The GND terminals of all bus modules must be connected. ▶ Do not connect the connector to the XV300 or disconnect it without first de-energizing the system.

Tab. 14: PIN assignment RS-232

SUB-D plug 9-pole, not galvanically isolated, UNC nuts for interlocking

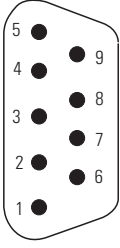
SUB-D plug	PIN	signal	Description
9 pole 	1	DCD	Data Carrier Detect
	2	RXD	Receive Data
	3	TXD	Transmit Data
	4	DTR	Data Terminal Ready
	5	GND	Signal Ground
	6	DSR	Data Set Ready
	7	RTS	Request to Send
	8	CTS	Clear To Send
	9	RI	Ring Indicator
Plug housings	GND	Functional earth	

5.5.1.1 Wiring topic

- Shielded cables must be used.
- The maximal baud rate depends on the cable length

Tab. 15: RS-232 cable length based on baud rate

Cable length	Max. baud rate
2.5 m	115200 Bit/s
5 m	57600 Bit/s
10 m	38400 Bit/s
15 m	19200 Bit/s
30 m	9600 Bit/s



When preparing connections, ensure that the cable shield has a low impedance connection with the connector housing.

5. External connections

5.5 Serial interfaces for communication with PLCs or devices

5.5.2 RS-485 COM2

The RS485-The interface is not electrically isolated.



CAUTION
NON-GALVANICALLY-ISOLATED INTERFACES

The XV300 may be damaged by potential differences.

- ▶ The GND terminals of all bus modules must be connected.
- ▶ Do not connect the connector to the XV300 or disconnect it without first de-energizing the system.

Tab. 16: Pin assignment RS-485

SUB-D plug 9-pole, not galvanically isolated, UNC nuts for interlocking

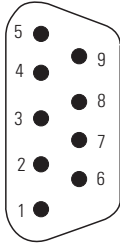
SUB-D plug	PIN	signal	Description
9 pole 	1	n.c.	not used
	2	n.c.	not used
	3	B	Line B
	4	n.c.	not used
	5	GND	Ground
	6	5 V	Output for external clamping
	7	A	A cable
	8	n.c.	not used
	9	n.c.	not used
	Plug housings	GND	Functional earth

➔ n.c.: PIN 1, 2, 4, 8 and 9 must not be connected.

➔ Pin 6 (5 V) must not be used as a power supply for external devices.

Wiring topic

- Screened twisted-pair cables must be used.
- The maximal baud rate depends on the cable length.

Tab. 17: Specifications for RS-485 wiring

Rated cable impedance	120 Ohm
Permissible impedance	108 ... 132 Ohm
Max. cable length	1200 m
Possible baud rates	9600 Bit/s
	19200 Bit/s
	38400 Bit/s
	57600 Bit/s
	115200 Bit/s

➔ When preparing connections, ensure that the cable shield has a low impedance connection with the connector housing.

5. External connections

5.5 Serial interfaces for communication with PLCs or devices

RS-485 topology

- A bus segment can interconnect up to 32 slaves.
- Several bus segments can be connected using repeaters (bi-directional amplifiers).



The use of repeaters enables the maximum cable length to be increased.

For more details, please consult the documentation provided by manufacturer.

A bus segment must be provided with cable termination (120 Ohm) at both ends.

These terminals must be connected in the plug directly between pin 3 and 7.



The bus segment must be terminated at both ends.

There must not be more than two terminations per bus segment.

Running the bus segment without the right termination may result in transmission errors.

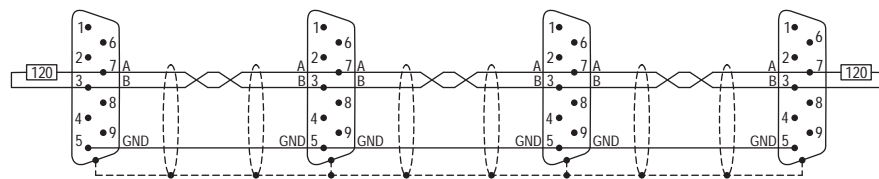



Fig. 29: Bus segment with four nodes

5.6 CAN1 interface for the CANopen protocol, J1939 protocol, etc.

5.6 CAN1 interface for the CANopen protocol, J1939 protocol, etc.

The CAN1-The interface is not electrically isolated.



CAUTION
NON-GALVANICALLY-ISOLATED INTERFACES

The XV300 may be damaged by potential differences.

- ▶ The GND terminals of all bus modules must be connected.
- ▶ Do not connect the connector to the XV300 or disconnect it without first de-energizing the system.

Tab. 18: PIN assignment for CAN interface as specified in CiA)
 SUB-D plug 9-pole, not galvanically isolated, UNC nuts for interlocking

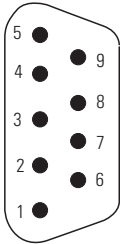
SUB-D plug	PIN	signal	Description
9 pole 	1	n.c.	not used
	2	CAN-L	Bus line (dominant low)
	3	GND	Ground
	4	n.c.	not used
	5	n.c.	not used
	6	GND	Optional Ground
	7	CAN-H	Bus line (dominant high)
	8	n.c.	not used
	9	n.c.	not used



- nc: PIN 1, 4, 5, 8 and 9 must not be connected.
- PIN 3 (CAN-GND) and 6 (GND) are internally inter-connected.
- The power supply of the CAN bus drivers is implemented internally.
- A power supply for third party devices is not provided on the CAN connector.

Wiring topic

- Screened twisted-pair cables must be used.

Tab. 19: Specifications for CAN wiring

Rated cable impedance		120 Ohm	
Permissible impedance		108 ... 132 Ohm	
Capacitance per unit length		< 60 pF/m	
Core cross-section		100 m	0.25 mm ²
	With a max. cable length of	250 m	0.34 mm ²
		500 m	0.75 mm ²

5. External connections

5.6 CAN1 interface for the CANopen protocol, J1939 protocol, etc.

The maximal baud rate depends on the cable length.

Possible baud rates	With a max. cable length of	25 m	1000 kBit/s
		50 m	800 kBit/s
	100 m	500 kBit/s	
	250 m	250 kBit/s	
	500 m	125 kBit/s	
	500 m	100 kBit/s (can be set through software)	
	1000 m	50 kBit/s	
	2500 m	20 kBit/s	
	5000 m	10 kBit/s	



When preparing connections, ensure that the cable shield has a low impedance connection with the connector housing.

CAN-Bus-topology

- A bus segment can interconnect up to 32 slaves.
- Several bus segments can be connected using repeaters (bi-directional amplifiers).



The use of repeaters enables the maximum cable length to be increased.

Repeaters can also be used for galvanic isolation. For more details, please consult the documentation for repeaters provided by manufacturer.

Make sure to follow the recommendations provided by CiA (CAN in Automation) at can-cia.org.

A bus segment must be provided with cable termination (120 Ohm) at both ends.

These terminals must be connected in the plug directly between pin 2 and 7.



The bus segment must be terminated at both ends.

There must not be more than two terminations per bus segment.

Running the bus segment without the right termination may result in transmission errors.

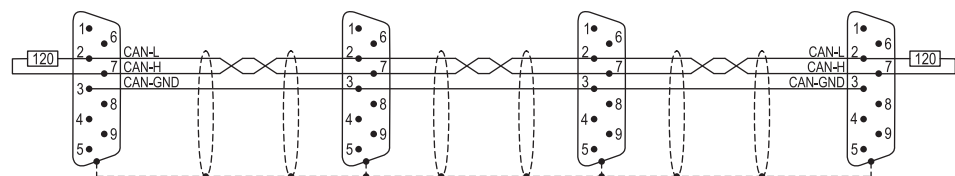

Fig. 30: CAN bus segment with four nodes

6. Faults

This section provides troubleshooting information for your XV-303/XV-313 multi-touch display in case it does not behave as expected.

Fault	Cause	Remedy
XV300 will not boot up	No 24 VDC supply voltage	Check the input wiring. Switch on XV300.
The display stays or turns dark.	The backlight is deactivated.	Switch the backlight on; please refer to the Linux system description or to the corresponding function in the visualization software.
The Capacitive multi-touch technology (PCT) is not responding or is responding incorrectly when used.	The functional earthing has not been connected properly.	The XV-303/XV-313 multi-touch display needs to be connected to the conductive structure in, e.g., the control panel using the central earth point (earthing screw). Ground connection characteristics: Wire cross-sectional area $\geq 1.5 \text{ mm}^2$, length $\leq 350 \text{ mm}$
	The touch is not calibrated correctly.	Switch on XV300. Calibrate the touch functionality; please refer to the Linux system description
	The touch is disabled.	Switch on XV300. Enable the touch functionality; please refer to the Linux system description

7. Maintenance

7.1 Cleaning and maintenance

The XV-303/XV-313 multi-touch display are maintenance-free.
However, the following work may need to be carried out:

- Cleaning the Capacitive multi-touch technology (PCT) when soiled.
- Recalibrating the Capacitive multi-touch technology (PCT) if it stops responding correctly to touch.

7.1.1 Capacitive multi-touch technology (PCT)

When soiled:



CAUTION

POINTY, SHARP OBJECTS AND CORROSIVE LIQUIDS

When cleaning the XV-303/XV-313 multi-touch display:

- Do not use any pointy or sharp objects (e.g., knives).
- Do not use aggressive or abrasive cleaning products or solvents.

Make sure that no liquids get into the XV-303/XV-313 multi-touch display unit (short-circuit hazard) and that the XV-303/XV-313 multi-touch display unit is not damaged in any way.

- ▶ Clean the Capacitive multi-touch technology (PCT) with a clean, soft, damp cloth.

7.1.2 Battery

The internal battery used to back up the real-time clock is maintenance-free and is sized for a backup time of normally 10 years at 25° C (77°F) when de-energized, provided the corresponding ambient conditions are met.

7. Maintenance

7.2 Repairs

7.2 Repairs

For repairs, please contact your vendor or Eaton's Technical Support.



CAUTION DESTRUCTION

The XV-303/XV-313 multi-touch display should only be opened by the manufacturer or by an authorized center. Operate the XV300 until only with the enclosure fully closed and sealed.

Use the original packaging to ship the device.

7.3 Storage, transport and disposal

7.3.1 Storage and transport



CAUTION UV LIGHT

Plastics will become brittle when exposed to UV light. This artificial aging will reduce the XV-303/XV-313 multi-touch display unit's lifespan. Protect the XV300 unit from direct sunlight and other sources of UV radiation.



CAUTION SHORT-CIRCUIT HAZARD

If the XV300 multi-touch display is or has been exposed to environmental fluctuations (ambient temperature, air humidity), condensation may form on or inside. As long as this condensation is present, there will be a short-circuit hazard.

Do not switch on the XV300 multi-touch display when it has condensation in or on it.

If the XV300 multi-touch display has condensation in or on it, or if the panel has been exposed to environmental fluctuations, let the panel settle into the existing ambient temperature before switching it on.

Do not expose the XV300 multi-touch display to direct thermal radiation from heating appliances.

The ambient conditions must be met when transporting and storing the XV-303/XV-313 multi-touch display.

The ambient air temperature for storage and transportation must not exceed the maximum specified limit:

7. Maintenance

7.3 Storage, transport and disposal

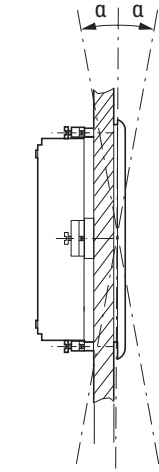
Ambient climatic conditions	
Air pressure (in operation)	795 - 1080 hPa Max. 2000 m above sea level
Temperature	<div style="display: flex; justify-content: space-between;"> <div style="width: 45%;"> <p style="text-align: center;">Operation</p> <p style="text-align: center;">Mounting position</p>  <p style="text-align: center;">Storage / Transport</p> </div> <div style="width: 50%;"> <p>± 0 – +50 °C (+32 – +122 °F)</p> <p>XV-303-70-..., XV-303-10-..., XV-313 α ≤ ± 45°, T ≤ 50 °C (122 °F)</p> <p>XV-303-15-.. α ≤ ± 10°, T ≤ 50 °C (122 °F) α ≤ ± 45°, T ≤ 45 °C (113 °F)</p> <p>Inclination from vertical: α ≤ ± 45° at operating temperature ≤ 45°C (113°F) possible (if using natural convection)</p> </div> </div>
Humidity	Relative humidity 10 - 95 %
Condensation	non-condensing



Before commissioning

If storing/transporting the device in cold weather conditions or in such a way that it will be exposed to extreme differences in temperature, make sure that no condensation forms on or inside the device.

If there is condensation in or on the device, do not switch on the HMI-PLC until it is completely dry.

Use the original packaging to ship the device.

The XV-303/XV-313 multi-touch display is sturdily built, but the components inside it are sensitive to excessively strong vibrations and/or mechanical shock.

Accordingly, make sure to protect the XV-303/XV-313 multi-touch display from mechanical loads that exceed the scope of the unit's intended use.

The XV300 should only be transported in its original packaging after being packed properly.

7. Maintenance

7.3 Storage, transport and disposal

7.3.2 Disposal



EXPLOSION HAZARD LITHIUM BATTERY

The lithium battery inside the XV-303/XV-313 multi-touch display may explode if handled incorrectly.

- ▶ Dispose of the XV300 unit professionally.



Important!

Dispose of recyclables as required by your local recycling regulations.

XV-303/XV-313 multi-touch display no longer being used must be professionally disposed of as per local standards or returned to the manufacturer or relevant sales department.

Tab. 20: Materials used XV-303/XV-313 multi-touch display

Assembly part		Material
Display	XV-303	Anti-glare tempered glass in plastic bezel
	XV-313	Anti-glare tempered glass without bezel, Front side with aluminum frame
Enclosure material		Insulated material black
Battery	Panasonic	Lithium BR-2330/GNU, 3V, 255 mAh, Weight (g): 3.7 SVHC Substance: ethylene glycol dimethyl ether Substance weight (%): 2-4

Materials used in the packaging

Packaging	Material
Outer packaging	Cardboard
Inner packaging	Cardboard
	Plastic bag: polyethylene (PE)

Appendix

<u>A.1 Technical data</u>	69
A.1.1 Data sheets	69
A.1.2 Dimension and weight specifications	71
A.1.3 General data	78
A.1.4 Port and interface specifications	80
A.1.5 Information on the power supply	81
A.1.6 Approvals and declarations	82
<u>A.2 Further usage information</u>	84

Appendix

A.1 Technical data

A.1 Technical data

A.1.1 Data sheets

The current specifications for the device can be found in the corresponding data sheet at Eaton.com/ecat

Currently available for front installation with Capacitive multi-touch technology (PCT) widescreen:

Basic features	Display	Catalog Number	
1 Slot for 1 SD-card Integrated interfaces: 1 x Ethernet 100/10, 1 x USB host, 1 x USB device, 1 x RS-485, 1 x RS-232, 1 x CAN	7.0"	XV-303-70-B00-A00-2B	EP-401361
	10.1"	XV-303-10-B00-A00-2B	EP-401365

Basic features	Display	Catalog Number	
1 Slot for 1 SD-card Integrated interfaces: 1 x Ethernet 100/10, 1 x USB host, 1 x USB device, 1 x RS-485, 1 x RS-232, 1 x CAN PLC function	7.0"	XV-303-70-B00-A00-2C	EP-401363
	10.1"	XV-303-10-B00-A00-2C	EP-401367

Basic features	Display	Catalog Number	
1 Slot for 1 SD-card Integrated interfaces: 2 x Ethernet 100/10, 1 x USB host, 1 x USB device, 1 x RS-485, 1 x RS-232, 1 x CAN	7.0"	XV-303-70-C00-A00-2B	EP-401362
	10.1"	XV-303-10-C00-A00-2B	EP-401366
	15.6"	XV-303-15-C00-A00-2B	EP-401369

Basic features	Display	Catalog Number	
1 Slot for 1 SD-card Integrated interfaces: 2 x Ethernet 100/10, 1 x USB host, 1 x USB device, 1 x RS-485, 1 x RS-232, 1 x CAN PLC function	7.0"	XV-303-70-C00-A00-2C	EP-401364
	10.1"	XV-303-10-C00-A00-2C	EP-401368
	15.6"	XV-303-15-C00-A00-2C	EP-401370

Currently available for rear (wall) installation with Capacitive multi-touch technology (PCT) widescreen:

Basic features	Sheet thickness of the installation panel	Display	Catalog Number	
1 Slot for 1 SD-card Integrated inter- faces: 1 x Ethernet 100/10, 1 x USB host, 1 x USB device, 1 x RS-485, 1 x RS-232, 1 x CAN PLC function	d = 1.5 mm (0.059") ± 0.1mm (0.004")	7.0"	XV-313-70-B00-A00-2C	EP-401371
	d = 2 mm (0.08") ± 0.1mm (0.004")	10.1"	XV-313-10-B00-A11-2C	EP-401372
	d = 1.5 mm (0.059") ± 0.1mm (0.004")		XV-313-10-B00-A00-2C	EP-401373

Basic features	Sheet thickness of the installation panel	Display	Catalog Number	
1 Slot for 1 SD-card Integrated inter- faces: 2 x Ethernet 100/10, 1 x USB host, 1 x USB device, 1 x RS-485, 1 x RS-232, 1 x CAN PLC function	d = 1.5 mm (0.059") ± 0.1mm (0.004")	10.1"	XV-313-10-C00-A00-2C	EP-401374

Appendix

A.1 Technical data

A.1.2 Dimension and weight specifications

A.1.2.1 XV-303 Front mounting

7.0" Display

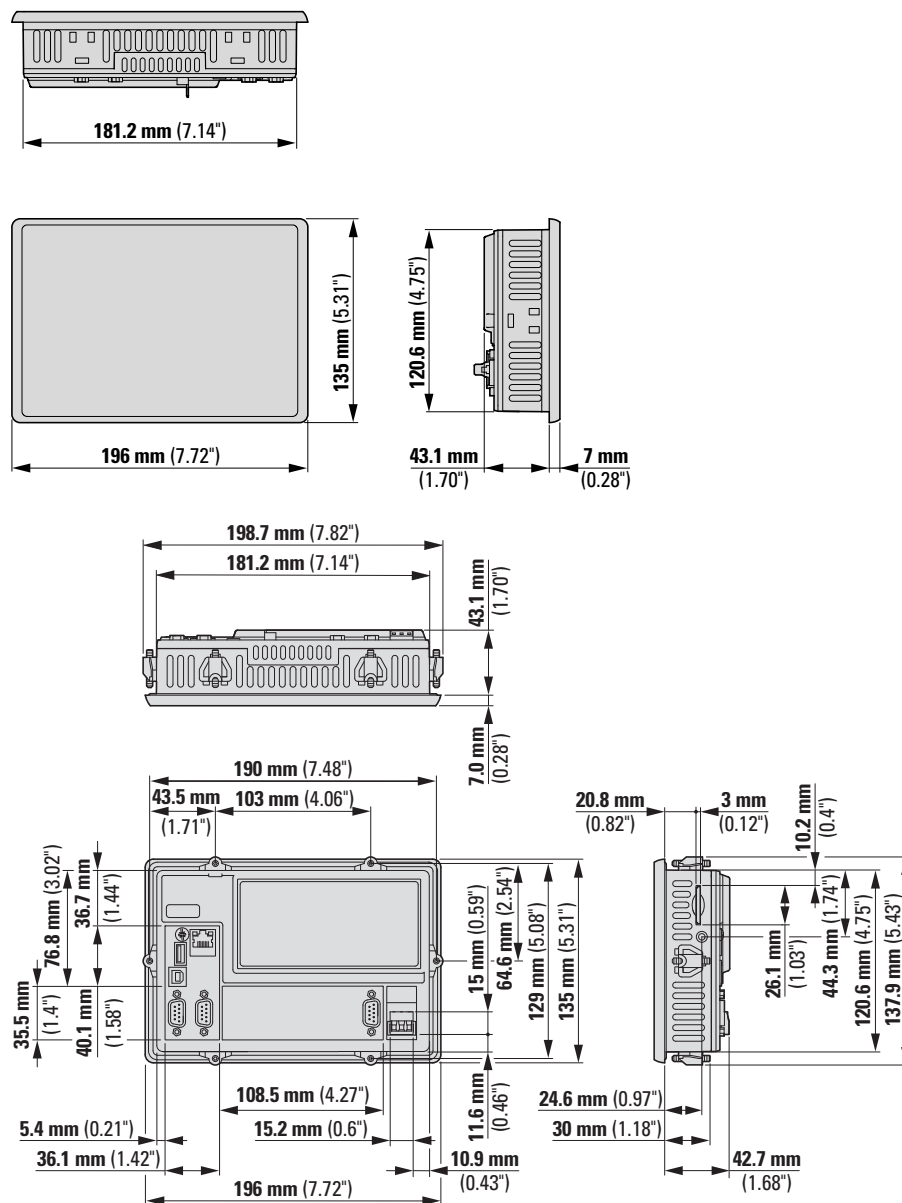

Fig. 31: Dimensions for 7.0" front mounting devices in mm (inches)

Width x Height x Depth 196 mm x 135 mm x 51 mm (7.72" x 5.31" x 2.01")
(without plug)

Weight 0.74 kg (1.63 lbs)

Appendix

A.1 Technical data

15.6" Display

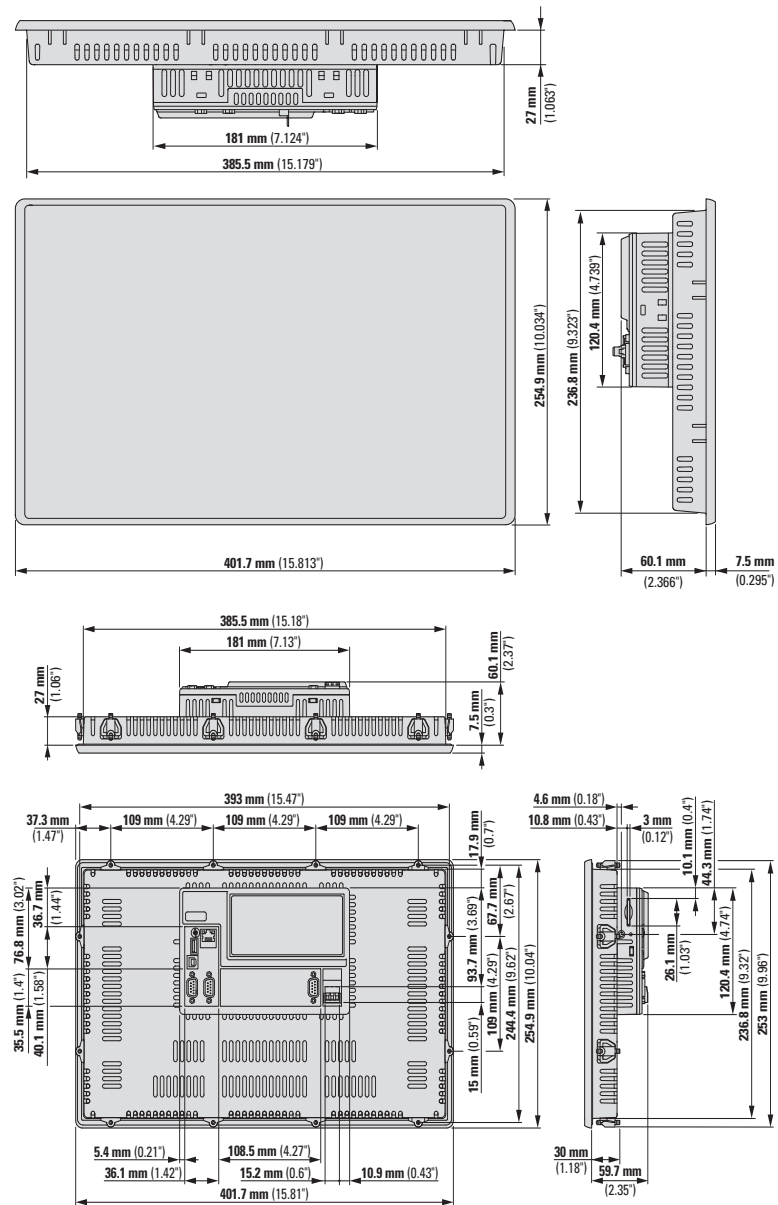

Fig. 33: Dimensions for 15.6" front mounting devices in mm (inches)

Width x Height x Depth 401.7 mm x 254.9 mm x 67.6 mm ±0.2 (15.9" x 10.04" x 2.661" ±0.008)
(without plug)

Weight 3.25 kg (7.17 lbs)

A.1.2.2 XV-313 Rear (panel) mounting

7.0" Display XV-313-...-A00-..

Sheet thickness of the installation panel $d = 1.5 \text{ mm (0.059")} \pm 0.1 \text{ mm (0.004")}$

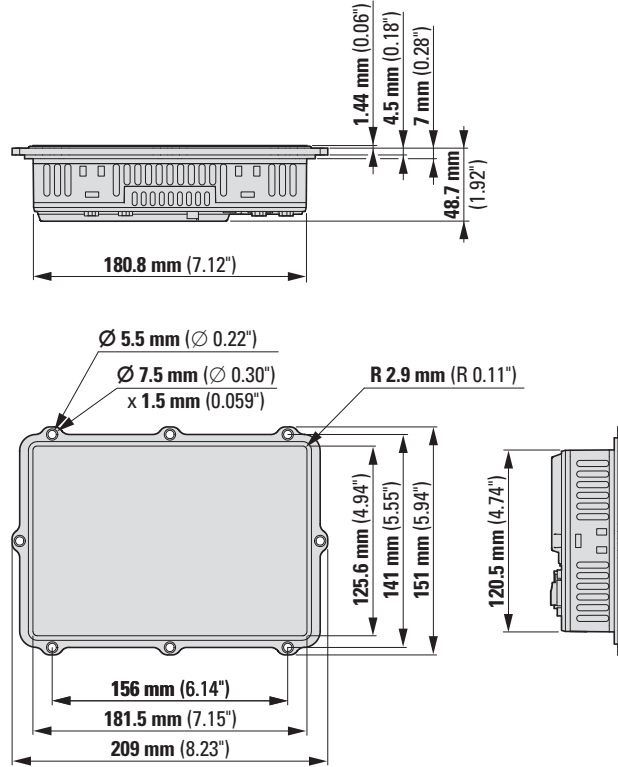

Fig. 34: Dimensions for 7.0" rear (panel) mounting devices in mm (inches) XV-313-...-A00-..

Width x Height x Depth 209 mm x 151 mm x 51 mm (8.23" x 5.94" x 2.01")
(without plug)

Weight 0.8 kg (1.76 lbs)

**Appendix
A.1 Technical data**

10.1" Display XV-313-...-A00-..

Sheet thickness of the installation panel $d = 1.5 \text{ mm (0.059")} \pm 0.1 \text{ mm (0.004")}$

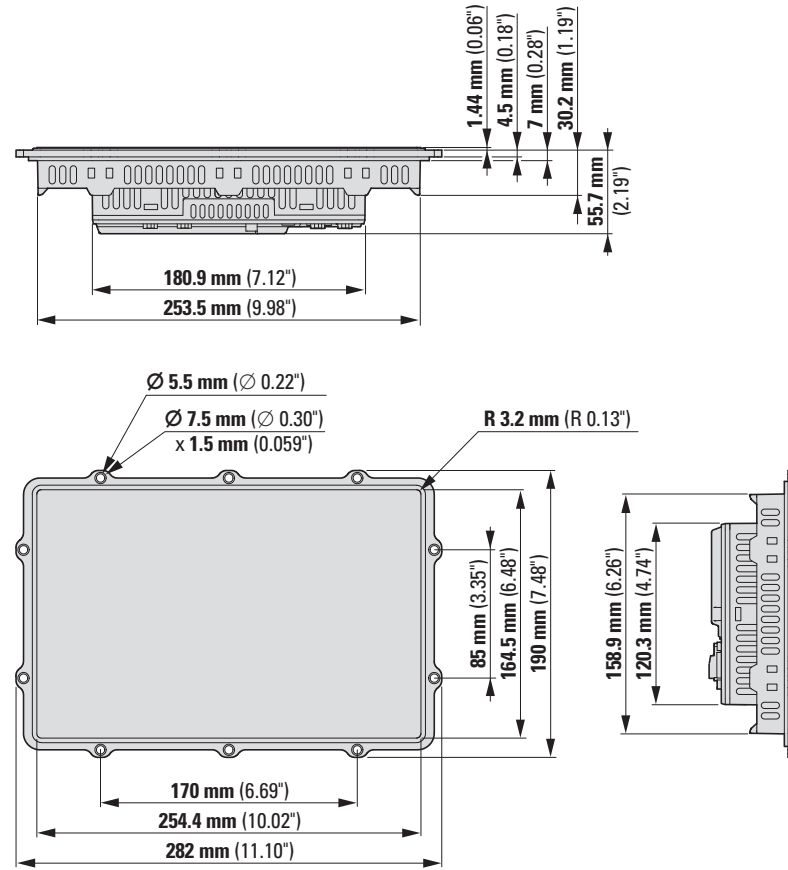

Fig. 35: Dimensions for 10.1" rear (panel) mounting devices in mm (inches)XV-313-...-A00-..

10.1" Display XV-313-...-A11-..

Sheet thickness of the installation panel $d = 2 \text{ mm}$ (0.08") $\pm 0.1 \text{ mm}$ (0.004")

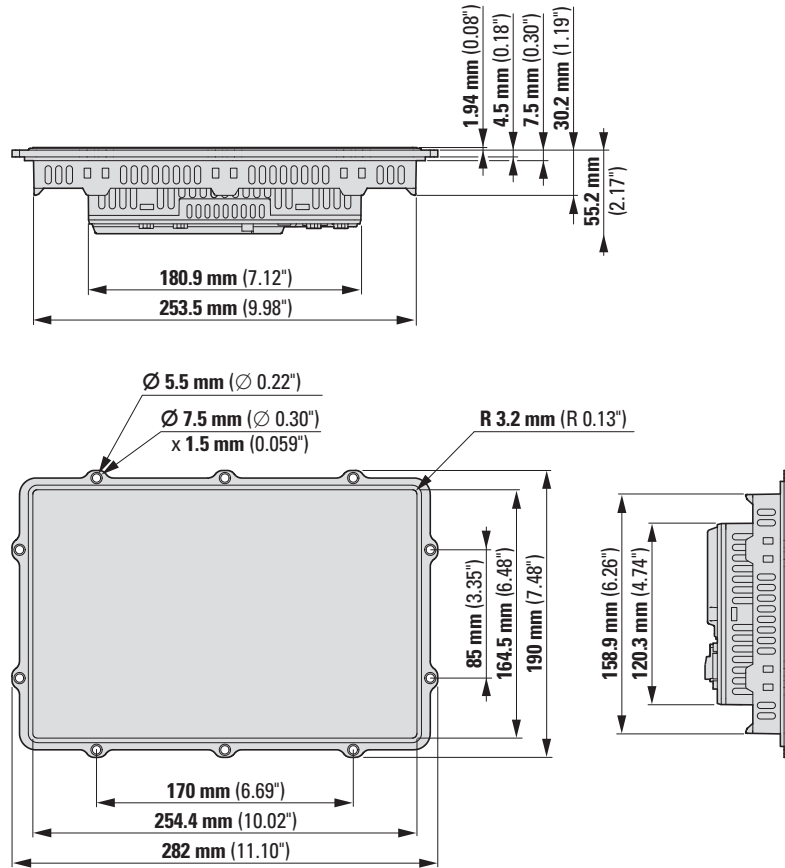

Fig. 36: Dimensions for 10.1" rear (panel) mounting devices in mm (inches) XV-313-...-A11-..

Width x Height x Depth 282 mm x 190 mm x 58 mm (11.10" x 7.48" x 2.28")
(without plug)

Weight 1.21 kg (2.67 lbs)

Appendix A.1 Technical data

A.1.2.3 Mounting surrounds for rear (panel) mounting

Not a true-to-scale template! If necessary, make your own template based on the dimensional drawing for mounting and the right scale.

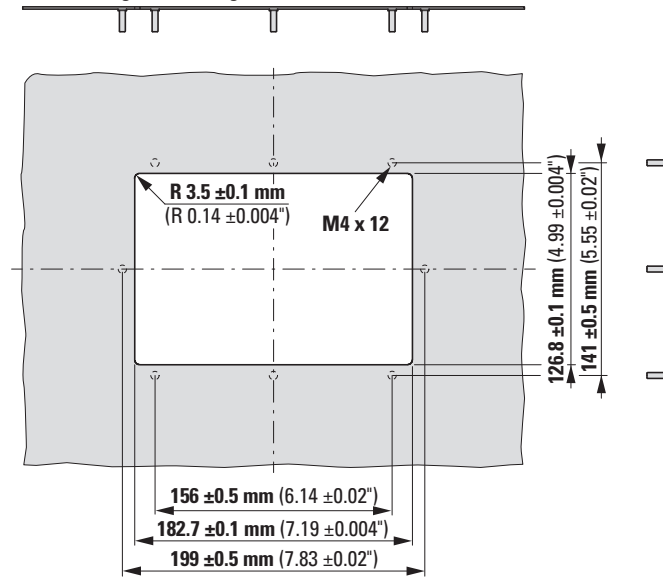

Fig. 37: Installation panel for XV-313-10-..

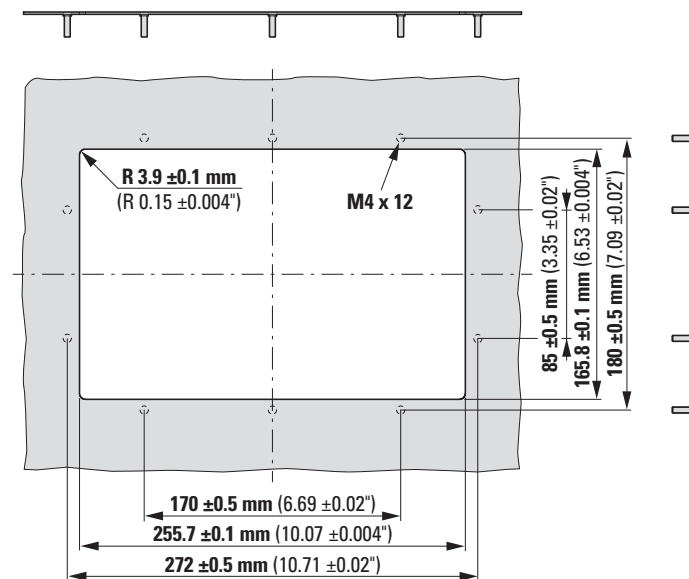

Fig. 38: Installation panel for XV-313-70-..

A.1.3 General data

The following specifications apply to all XV-303/XV-313 multi-touch display units or to the specified part nos. where applicable.

General	
type	
XV-303	Plastic enclosure and glass panel in plastic frame
XV-313	Plastic enclosure and glass panel in aluminum mounting frame
Degree of protection	IP65 (at front), IP20 (at rear) NEMA 4X, NEMA 12 (as per NEMA 250-2003)
Operation	
Technology	Projected Capacitive Touch (PCT)
Touch sensor	Multi-touch touch panel
System	
Processor	ARM Cortex-A9 800 MHz
Internal memory	512 MB RAM, 1GB SLC, 128kB Retain
SD card slots	One SDSC or SDHC conforming to the SDA 2.0 specification – use genuine accessories only!
Cooling	Fanless CPU and system cooling, natural convection-based passive cooling
Back-up of real-time clock	
Battery (lifespan)	Non-maintained
Backup (time at zero voltage)	normally 10 years at 25° C (77°F)
Operating System	Linux

Appendix

A.1 Technical data

Display	
Display - Type	Color display, TFT, anti-glare
Number of Colors	≈ 16.7 mill. (color depth 24 bit)
Resolution	
XV-303-70-..., XV-313-70-... XV-303-10-..., XV-313-10-...	WSVGA 1024 x 600 pixels
XV-303-15-..	WXGA 1366 x 768 pixels
Screen diagonal	
XV-303-70-..., XV-313-70-..	7.0" widescreen
XV-303-10-..., XV-313-10-..	10.1" widescreen
XV-303-15-..	15.6" widescreen
Screen area visible	
XV-303-70-..., XV-313-70-..	153.6 mm x 90.0 mm
XV-303-10-..., XV-313-10-..	222.72 mm x 125.28 mm
XV-303-15-..	344.23 mm x 193.54 mm
Contrast ratio (Normally)	
XV-303-70-..., XV-313-70-..	normally 850:1
XV-303-10-..., XV-313-10-..	normally 500:1
XV-303-15-..	
Brightness	Normally 400 cd/m2
Backlight	LED dimnable via software
Lifespan of backlight	Normally 50000 h at 25 °C

A.1.4 Port and interface specifications

Tab. 21: Interfaces, communication

Catalog Number	XV-303-...-B00-...	XV-303-...-C00-...
	XV-313-...-B00-...	XV-313-...-C00-...
Qty.		
Ethernet	1	2
USB host 2.0	1	1
USB device 2.0	1	1
RS-485	1	1
RS-232	1	1
CAN	1	1
Type		
Ethernet	RJ-45 socket, 8-pole, 2 LEDs (CAT5e/6), LAN1, 10/100 Mbps	
USB host	USB 2.0, not galvanically isolated, plug type A, Full power (500 mA)	
USB device	USB 2.0, not galvanically isolated, plug type B	
RS-485	SUB-D plug 9-pole, not galvanically isolated, UNC nuts for interlocking	
RS-232	SUB-D plug 9-pole, not galvanically isolated, UNC nuts for interlocking	
CAN	SUB-D plug 9-pole, not galvanically isolated, UNC nuts for interlocking	

Appendix

A.1 Technical data

A.1.5 Information on the power supply

The following specifications apply to all XV-303/XV-313 multi-touch display units.

Power Supply			
rated operating voltage	+ 24 VDC SELV (safety extra low voltage)/PELV (protective extra low voltage)		
permissible Voltage range	Effective: 19.2-30.0 V DC (rated operating voltage -20%/+25%)		
	Absolute with ripple: 18.0-31.2 V DC		
	Battery powered: 18.0-31.2 V DC (rated operating voltage -25%/+30%); 35 V DC for a duration of < 100 ms		
Voltage dips	Ability to accommodate brief voltage dips ≤ 10 ms from rated operating voltage (24 V DC), ≤ 5 ms from undervoltage (19.2 V DC)		
Power consumption	XV-303-10-..., XV-313-10-..	max. 14.4W Current consumption at 24 V DC: 11.9 W for basic device + 2.5 W for USB module	
	XV-303-70-..., XV-313-70-..	max. 18 W Current consumption at 24 V DC: 15.5 W for basic device + 2.5 W for USB module	
	XV-303-15-..	max. 21.6 W Current consumption at 24 V DC: 19.1 W for basic device + 2.5 W for USB module	
fuse	Yes (fuse not accessible)		
Potential isolation	no		
Electrical current	7.0" display	10.1" display	15.6" display
I_e	≤ 0.6 A	≤ 0.75 A	≤ 0.9 A
I_{TH}	1.0 A ² s	1.0 A ² s	1.0 A ² s

A.1.6 Approvals and declarations

The following specifications apply to all XV-303/XV-313 multi-touch display units.

Approvals and declarations	
cUL	UL 61010-2-201, UL File No. E205091
CE	XV300 units comply with all applicable European Union (EU) Directives and feature the CE marking.
NEMA	XV300 devices comply with the applicable guidelines in North America
Explosion protection	<p>II 3D Ex tc IIIC T70°C IP6x: zone 22, category 3D</p> <ul style="list-style-type: none"> • IP5x for group IIIB devices (nonconductive dust) • IP6x for group IIIC devices (conductive dust) <p>For front mounting: fixing material that must be installed as specified without fail -XV-303-10-...: on each 6 x Holding bracket with set screw -XV-303-70-...: Ten (10) Holding bracket with set screw -XV-303-15-...: Twelve (12) Holding bracket with set screw For rear (wall) mounting: fastened as specified at all mounting points without fail. -XV-313-10-...: on each 8 x -XV-313-70-...: on each 10 x</p>
Marine approval (shipping classification)	Type approval for the XV-303/XV-313 multi-touch display 7.0" and 10.1" – provided that a radio interference suppression filter for the device is installed in the wiring DNVGL-CG-0039, from 11/2015 DNV GL Type Approval Certificate No: TAA00000NC
Applied standards and directives	
EMC (relevant for CE)	2004/108/EEC 2014/30/EU
	IEC/EN 61000-6-2 Interference immunity for industrial environments
	IEC/EN 61000-6-4 Emitted interference for industrial environments
Explosion protection (relevant for CE)	ATEX directive 94/9/EG 2014/34/EG
	IEC/EN 60079-0 Explosive atmospheres: Equipment - General requirements
	IEC/EN 60079-31 Explosive atmospheres: Equipment dust ignition protection by enclosure "t"
Security	
	IEC/EN 60950 Safety of Information Technology Equipment
	UL 61010-2-201 Industrial Control Equipment → Section "Technical conditions for acceptance by Underwriters Laboratories Inc. (UL)", page 37
	DIN EN 60529 Degrees of protection provided by enclosures
	NEMA 250-2003 Enclosures for electrical equipment (1000 Volts maximum)
Product standards	
	DIN EN 60898-1:2006-03 Electrical accessories - Circuit-breakers for overcurrent protection for household and similar installations
	EN 50178_x Electronic equipment for use in power installations
	IEC/EN 61131-2 Programmable controllers: Equipment requirements and tests
Mechanical shock resistance	IEC/EN 60068-2-27 15g /11ms

Appendix A.1 Technical data

Applied standards and directives		
Vibration	IEC/EN 60068-2-6	Displacement amplitude: 5–9 Hz: 3.5 mm; 9–60 Hz: 0.15 mm Acceleration amplitude: 60–150 Hz: 2 g
Free fall, packaged	IEC/EN 60068-2-31	
RoHS	Directive 2011/65/EG	conform
Climatic proofing	Cold to IEC 60068-2-1	
	Damp heat as per EN 60068-2-3	
	Dry heat to IEC60068-2-2	

Tab. 22: Overcurrent and short-circuit protective device standards

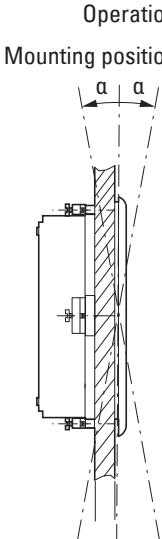

Standard	Overcurrent and short-circuit protective device
DIN VDE 0641, part 11 and EC/EN 60898	Miniature circuit-breaker 24 V DC, rated operational current 3 A, trip type Z fuse 3 A, Utilization category gL/gG
UL 61010-2-201	Miniature circuit-breaker 24 V DC, rated operational current 2 A, trip type Z fuse 2 A

Ambient climatic conditions	
Air pressure (in operation)	795 - 1080 hPa Max. 2000 m above sea level
Temperature	<p>Operation $\pm 0 - +50$ °C (+32 - +122 °F)</p> <p>Mounting position XV-303-70-..., XV-303-10-..., XV-313 $\alpha \leq \pm 45^\circ$, $T \leq 50$ °C (122 °F)</p>  <p>XV-303-15-.. $\alpha \leq \pm 10^\circ$, $T \leq 50$ °C (122 °F) $\alpha \leq \pm 45^\circ$, $T \leq 45$ °C (113 °F) Inclination from vertical: $\alpha \leq \pm 45^\circ$ at operating temperature $\leq 45^\circ$C (113°F) possible (if using natural convection)</p> <p>Storage / Transport -20 - + 60 °C (-4 - +140 °F)</p>
Humidity	Relative humidity 10 - 95 %
Condensation	non-condensing



A.2 Further usage information

For more information on additional devices and modules or the use of XV300, please refer to the following documentation:

Hardware

-  [XV-303-70-..., XV-303-10-... installation instructions](#) IL048022ZU
-  [XV-313-70-..., XV-313-10-... installation instructions](#) IL048023ZU

Software

-  GALILEO 11 - user help is available in the software MN048032EN
-  [System description for embedded Linux](#) MN050017EN

Communication



HMI-PLCs are able to communicate with a variety of PLCs. In order to integrate your XV300 into your system, additional settings will need to be configured as appropriate for the PLC being used.

The following documents, together with other documentation, explain what needs to be taken into account and configured:

-  Networks in Brief MN05010009Z

Download Center,Eaton Online Catalog

Enter "XV300" into the search box and the catalog will take you directly to the corresponding product group in the Automation, Control and visualization section.

-  Eaton.com/documentation
-  Eaton.com/ecat

Product information

For up-to-date information, please consult the product page on the Internet.

-  Eaton.com/xv300

Alphabetical index

A

Accessory devices	21
Aeration and de-aeration	35
After Sales Service	2
Ambient climatic conditions	34, 66, 83
Approvals	82

B

Basic equipment	15
Battery	64
Brand names	
Product names	2
Bundle	21

C

CAN	19, 54
CAN1	61
CANopen	61
Capacitive multitouch	64
Cleaning	64
Commissioning	51
Company information	2
Connections	
External	53
Cooling	78
Copy-protected	2
Copyright	2
CTRL button	18
Current	47, 81

D

Damage	41
--------------	----

Declarations	82
--------------------	----

Degree of protection	78
----------------------------	----

Device variants	15
-----------------------	----

Dimension

7.0" Display front mounting	71
-----------------------------------	----

7.0" Display rear (panel) mounting	74
--	----

10.1" Display front mounting	72
------------------------------------	----

10.1" Display rear (panel) mounting	75-76
---	-------

15.6" Display front mounting	73
------------------------------------	----

Dimensional drawing for mounting	77
--	----

Dimensions	71
------------------	----

Directives	82
------------------	----

Display	18, 79
---------------	--------

Disposal

Recycling	67
-----------------	----

Download Center	84
-----------------------	----

E

Earthing	48
----------------	----

ecat	84
------------	----

Enclosure material	78
--------------------------	----

Equipment supplied	40
--------------------------	----

Ethernet	57
----------------	----

Ethernet 1	19, 54
------------------	--------

Ethernet 2	19, 54
------------------	--------

F

Faults	63
--------------	----

Features	13
----------------	----

Front	18
-------------	----

Front mounting	42
----------------------	----

Function	13
----------------	----

Functional earthing	
Specifications	48
Further reading	84
G	
General data	78
H	
Hazards	
Device-specific	27
Hole diameter built-in	36
I	
Initial commissioning	51
Installation	33
Installation position	
Clearances	36
Selection	33
Intended use	14
Interfaces	19, 80
Basic	54
CAN1	61
Equipment	19
Ethernet	57
RS-232	58
RS-485	59
SD card	55
Serial	58
Type	19, 54
USB device	56
USB host	56
USB peripheral devices	56
J	
J1939	61

L	
Label	22
Lifespan	79
Backlight	52
Location of use	33
M	
Maintenance	64
Manuals	84
Marine approval	38
Marine approvals	24
Materials used	67
Missing parts	41
Mounting	41
Mounting distance	35
Mounting position	
SD card	33
Mounting-,Mounting cutout	44
N	
Nameplate	19, 22
O	
Online Catalog	84
Operating elements	18
Operating System	78
Operation	
Proper	26
Original Operating Instructions	2
P	
Package contents	40
Part number	20
PCT	64

Peculiarities		Touch sensor	18, 78
SmartWire-DT	14	Transit damage	40
XN300	14	Transport	65
Ports	53	Troubleshooting	63
Power consumption	47, 81		
Power supply	47, 49, 81	U	
R		UL listing	23
Radio interference filter	38	USB device	19, 54, 56
Real-time clock	78	USB host	19, 54, 56
Rear (wall) mounting	44	USB peripheral devices	56
Repairs	65	V	
Resolution		Versions	15, 20
Display	79	Voltage range	47, 81
RS-232	19, 54, 58		
RS-485	19, 54, 59	W	
S		Weight	71
Safety	25		
Screen area			
visible	79		
Screen diagonal	79		
SD card	55		
SD card slot	18-19, 54		
Sealing	41		
Service	22		
Service side	18		
Shipping classification	24, 38		
Standards	82		
Std. pack	40		
Storage	65		
Support	22		
System	78		
T			
Technical data	69		

Eaton is an intelligent power management company dedicated to protecting the environment and improving the quality of life for people everywhere. We make products for the data center, utility, industrial, commercial and institutional, machine building, residential, aerospace and mobility markets. We are guided by our commitment to do business right, to operate sustainably and to help our customers manage power – today and well into the future. By capitalizing on the global growth trends of electrification and digitalization, we're helping to solve the world's most urgent power management challenges and building a more sustainable society for people today and generations to come.

Founded in 1911, Eaton has continuously evolved to meet the changing and expanding needs of our stakeholders.

With revenues of \$27.4 billion in 2025, the company serves customers in 180 countries.

For more information, visit eaton.com. Follow us on [LinkedIn](#).



Powering Business Worldwide

Eaton Industries GmbH
Hein-Moeller-Str. 7-11
D-53115 Bonn

© 2025 Eaton Corporation
04/2026 MN048031EN (PMCC)