

## XV-102-L-... touchdisplay



## **Company information**

All brand and product names are trademarks or registered trademarks of their respective owners.

### **Service**

For service and support, please contact your local sales team.

Contact info: [Eaton.com/contact](https://Eaton.com/contact)

Service page: [Eaton.com/aftersales](https://Eaton.com/aftersales)

### **Original Operating Instructions**

is the German-language edition of this document

Publication date

04/2026, Edition 1.3

Copyright

© 2023 by Eaton Industries GmbH, 53105 Bonn

All rights, including those of translation, reserved.

No part of this manual may be reproduced, stored in a retrieval system, or transmitted in any form or by any means, whether electronic, mechanical, photocopying, micro-filming, recording, or otherwise, without the prior written permission of Eaton.

Subject to alteration.



**DANGER!**

Hazardous electrical voltage!

---

## **Before starting with the installation**

- Installation requires qualified electrician
  - Disconnect the power supply of the device.
  - Secure against retriggering
  - Verify isolation from the supply
  - Ground and short-circuit
  - Cover or enclose any neighboring live parts.
  - Follow the engineering instructions (IL) of the device concerned.
  - Only suitably qualified personnel in accordance with EN 50110-1/-2 (VDE 0105 part 100) may work on this device/system.
  - Before installation and before touching the device ensure that you are free of electrostatic charge.
  - The functional earth (FE) must be connected to the protective earth (PE) or to the equipotential bonding. The system installer is responsible for implementing this connection.
  - Connecting cables and signal lines should be installed so that inductive or capacitive interference does not impair the automation functions.
  - Install automation devices and related operating elements in such a way that they are well protected against unintentional operation.
  - Suitable safety hardware and software measures should be implemented for the I/O interface so that a line or wire breakage on the signal side does not result in undefined states in the automation devices.
  - Deviations of the mains voltage from the nominal value must not exceed the tolerance limits given in the specifications, otherwise this may result in malfunction and hazardous states.
  - Emergency-Stop devices complying with IEC/EN 60204-1 must be effective in all operating modes of the automation devices. Unlatching the emergency stop devices must not result in an automatic restart.
  - Built-in devices for enclosures or cabinets must only be run and operated in an installed state;
- desktop devices and portable devices only when the housing is closed.
- Measures should be taken to ensure the proper restarting of programs interrupted after a voltage dip or outage. This should not result in dangerous operating states even for a short time. If necessary, emergency stop devices should be implemented.
  - Wherever faults in the automation system may cause damage to persons or property, external measures must be implemented to ensure a safe operating state in the event of a fault or malfunction (for example, by means of separate limit switches, mechanical interlocks, etc.).

## Table of Contents

	<b>XV-102-L-... touchdisplay Manual</b> .....	<b>1</b>
	Company information .....	2
	Before starting with the installation .....	3
	Table of Contents .....	4
0.1	About this documentation .....	7
0.1.1	List of revisions .....	7
0.1.2	Target group .....	8
0.1.3	Legal disclaimer .....	9
0.1.4	Device designations and abbreviations .....	9
0.1.5	Writing conventions .....	10
0.1.5.1	Warning labels .....	10
0.1.5.2	Additional information for use .....	11
<b>1.</b>	<b>Description</b> .....	<b>12</b>
1.1	Function .....	12
1.1.1	XV-102-L-... touchdisplay Features .....	12
1.2	Use as intended .....	13
1.3	Device models - versions and part nos. ....	14
1.3.1	Basic features .....	14
1.3.2	Optional features .....	14
1.4	Operating and indication elements .....	16
1.5	Interfaces to peripheral devices .....	17
1.6	What the different parts of the part number mean .....	18
1.7	Accessory devices .....	19
1.8	Nameplate .....	20
1.9	Support .....	20
1.10	Conditions for Underwriters Laboratories Inc. (UL) listing .....	21
1.11	Marine approvals .....	22
<b>2.</b>	<b>Safety regulations</b> .....	<b>23</b>
2.1	Basics .....	23
2.2	Mandatory requirements, personnel requirements .....	24

2.2.1	Occupational safety .....	24
2.2.2	Personnel qualifications .....	24
2.2.3	Device documentation .....	24
2.2.4	Installation, maintenance, and disposal .....	25
2.2.5	Prerequisites for proper operation .....	25
2.3	Device-specific hazards .....	26
<b>3.</b>	<b>Installation .....</b>	<b>31</b>
3.1	Prerequisites for the location of use .....	31
3.1.1	Installation position .....	31
3.1.1.1	Temperatures .....	32
3.1.1.2	Aeration and de-aeration .....	33
3.1.2	Technical conditions for acceptance by Underwriters Laboratories Inc. (UL) .....	34
3.1.3	Conditions for marine approval .....	35
3.1.3.1	Radio interference suppression filter for the 24-V-DC-supply .....	36
3.2	Unpacking and checking the equipment supplied .....	37
3.3	Mounting .....	38
3.4	Preparations .....	38
3.4.0.1	Criteria for the Installation position .....	39
3.5	XV-102 mounting .....	41
3.6	Preparing the device for operation .....	42
3.6.1	Functional earthing XV-102-L-... touchdisplay .....	43
3.6.2	Power supply - electrical connection .....	44
<b>4.</b>	<b>Commissioning .....</b>	<b>45</b>
4.1	Initial commissioning .....	45
4.2	Running the XV-102 .....	46
4.2.1	Display Characteristics of TFT Displays (Image Retention / Ghosting) .....	46
4.2.2	Notes on Visualization Project Design .....	46
<b>5.</b>	<b>External connections .....</b>	<b>48</b>
5.1	Layout of interfaces .....	49
5.1.1	Optional interfaces .....	49
5.2	SD card .....	50

5.3	USB interfaces .....	51
5.3.1	USB host .....	51
5.4	Ethernet 1 .....	52
5.5	Serial interfaces for communication with PLCs or devices .....	53
5.5.1	COM1 RS-232 .....	53
5.5.1.1	Wiring topic .....	53
5.5.2	COM2 RS-485 .....	54
5.6	CAN interface for the CANopen protocol, J1939 protocol, etc. ...	56
5.7	Screening the interface cables used .....	58
<b>6.</b>	<b>Faults .....</b>	<b>59</b>
<b>7.</b>	<b>Maintenance .....</b>	<b>60</b>
7.1	Cleaning and maintenance .....	60
7.1.1	Resistive touch .....	60
7.1.2	Battery .....	60
7.2	Repairs .....	61
7.3	Storage, transport and disposal .....	62
7.3.1	Storage and transport .....	62
7.3.2	Disposal .....	64
	<b>Appendix .....</b>	<b>65</b>
A.1	Technical data .....	66
A.1.1	Dimension and weight specifications .....	67
A.1.1.1	3.5" Display .....	67
A.1.1.2	5.7" Display .....	68
A.1.1.3	7.0" Display .....	69
A.1.2	General data .....	70
A.1.3	Port and interface specifications .....	72
A.1.4	Information on the power supply .....	73
A.1.5	Approvals and declarations .....	74
A.2	Further usage information .....	76
	Alphabetical index .....	77

## 0.1 About this documentation

### 0.1 About this documentation

This Manual contains all the information you will need in order to use the XV-102-L-... touchdisplay safely and effectively.

The Manual XV-102-L-... touchdisplay manual is considered an integral part of the devices and must always be readily available in the device's close proximity so that users have access to it.

This Manual describes all of the devices' lifecycle stages: transportation, installation, commissioning, operation, maintenance, storage, and disposal.

It assumes you have electrical engineering knowledge and skills.

It does not, however, go over the corresponding operating system or application software.

Make sure to always use the latest documentation for your device.



Manual XV-102-L-... touchdisplay

MN048030EN

The latest version of this documentation, as well as additional references, is available for download on the Internet. → Section "Further usage information", page 76



[Eaton.com/documentation](https://www.eaton.com/documentation)

Please send any comments, recommendations, or suggestions regarding this document to: [DocumentationEGBonn@eaton.com](mailto:DocumentationEGBonn@eaton.com)

#### 0.1.1 List of revisions

The following significant amendments have been introduced since previous issues:

Publication date	Keyword	New	Modification
01/2024	New version for "L devices" series	✓	
03/2025	Copyright and editorial date set to 2025 for English version (US market launch)		✓
09/2025	Device types added for easyE4	✓	
04/2026	Image Retention / Ghosting Notice	✓	

### 0.1.2 Target group

This Manual is intended for electricians and electrical engineers, as well as for the people who will be in charge of performing the electrical installation and people who will be using the XV-102-L-... touchdisplay as an operating and monitoring device or as an integrated operating and control device in their own applications.



#### **CAUTION**

Installation requires qualified electrician



#### **Follow the safety instructions for the XV-102!**

The section on safety instructions must be read and understood by everyone who will be working with the XV-102-L-... touchdisplay before the actual work is performed XV-102.



#### **WARNING**

##### **Incomplete operator manual copies**

Working with individual pages taken out from the operator manual may lead to bodily injury and property damage due to missing safety information.

- ▶ Always work with the latest and full document.

## 0.1 About this documentation

### 0.1.3 Legal disclaimer

All the information in this manual has been prepared to the best of our knowledge and in accordance with the state of the art. However, this does not exclude the possibility of there being errors or inaccuracies. We assume no liability for the correctness and completeness of this information. In particular, this information does not guarantee any particular properties.

Do not use the XV-102-L-... touchdisplay before reading and understanding this manual.

It is assumed that the user of this manual is thoroughly familiar with the information found in the manuals for incorporating the XV-102-L-... touchdisplay into automation processes.

Hazards posed by the XV-102 cannot be eliminated if the safety instructions are not observed – especially if the XV-102-L-... touchdisplay is commissioned and maintained by unqualified personnel and/or the XV-102 is used improperly. Eaton assumes no liability for any damages resulting from cases such as these.

### 0.1.4 Device designations and abbreviations

The following general terms are used throughout this manual:

Short designation	Explanation
XV-102-L-... touchdisplay	Product family with function code
HMI-PLC	Human-machine interface with programmable logic controller
XV-102	Device series
XV-102	Short description for all devices in the product family



For the exact designation for your XV-102-L-... touchdisplay, please refer to the → "Nameplate", Seite 20.

### 0.1.5 Writing conventions

Tab. 1: Format conventions used throughout this manual

<b>Award</b>	<b>Description</b>
<b>Bold text</b>	Used for all graphical user interface elements
Monospaced	Used for all elements at the file level
Font format code	
<code>Text</code>	Used for the button labels
<i>Menu path\submenu\...litem</i>	Path information for software windows and menu pages
<i>Menu/command</i>	Used for commands found in the menu bar's menus
<name>	Angle brackets are used to indicate variable values that you must replace with your own values

#### 0.1.5.1 Warning labels

##### Risk of personal injury warning.

	<b>DANGER</b> Warns of hazardous situations that result in serious injury or death.
--	--

	<b>WARNING</b> Warns of the possibility of hazardous situations that could result in serious injury or even death.
---	---

	<b>DANGER!</b> Dangerous Electrical Voltage!
---	---

	<b>CAUTION</b> Warns of the possibility of hazardous situations that can cause injury.
---	---

##### Property damage warning

<i>NOTICE</i> Warns about the possibility of material damage.
--



## **1. Description**

### **1.1 Function**

XV-102-L-... touchdisplay can be used as HMI devices or as integrated HMI/PLC devices.

#### **1.1.1 XV-102-L-... touchdisplay Features**

The devices

- Are a compact, powerful, and versatile solution for automation applications with limited installation space
- Can be used either as HMI operating units or, optionally, as HMI/PLC combination units with an integrated PLC function
- Feature a TFT display with Resistive touch technology
- Are available in 3.5" (4:3 aspect ratio), 5.7" (4:3 aspect ratio), and 7" (16:9 aspect ratio) versions
- Are housed in a plastic enclosure
- Can also be used in portrait mode
- Feature integrated working memory that can be expanded with an SD card if necessary
- Feature an integrated Ethernet interface and, depending on the specific model, may also feature CAN, RS-232, and RS-485 interfaces
- Approvals: UL, DNV-GL

#### **Standard features**

- 800 MHz RISC processor
- SD card slot for SD / SDHC memory cards

#### **Engineering**

- Programming with CODESYS version 3
- Visualization with GALILEO or CODESYS

## 1. Description

### 1.2 Use as intended

### 1.2 Use as intended

XV-102-L-... touchdisplay are primarily intended for use in machine and system building applications.

They are intended exclusively for monitoring, operating, and controlling machines and systems.

Any other use must be discussed and agreed upon with the manufacturer in advance.

The XV-102-L-... touchdisplay are approved for use in closed spaces.



#### **Important**

The XV-102-L-... touchdisplay must be used only in locations for which the XV-102 is approved. Make sure to read and follow the information and labels on the nameplate for the device, as well as section Approvals and declarations in the appendix.



#### **Prohibited uses, actions, etc.**

It is strictly prohibited to use the device in order to implement safety-relevant functions (in the sense of personal and machine protection).

## 1.3 Device models - versions and part nos.

### 1.3.1 Basic features

All XV are equipped with:

- the operating system Linux/Config Tool
- a SD/SDHC memory card slot.

Every XV-102-L-... touchdisplay comes with the following integrated interfaces as standard:

- One Ethernet port (10/100 Mbit/s) for use as a communication or field bus interface
- One USB 2.0 host port for memory and other accessories, full power (500 mA)

### 1.3.2 Optional features

The following individual options are available in order to ensure that the unit will best meet the needs of the application at hand:

- Three widescreen display sizes from 3.5", 5.7" (4:3 format) or 7.0" (16:9 format) with different resolution standards (QVGA, VGA, WVGA)

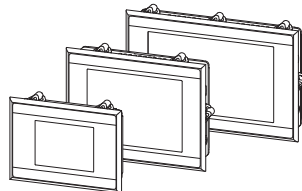

- Device bundles with visualization software and/or control software licenses.

Additional integrated interfaces

- One standard RS-232 (COM1) port for communicating with PLCs or devices
- One standard RS-485 (COM2) port for communicating with PLCs or devices
- One standard CAN interface for the CANopen protocol, J1939 protocol

# 1. Description

## 1.3 Device models - versions and part nos.

Tab. 2: XV-102-L-35-.. device versions for front installation



Fig. 1: Front with plastic bezel

Fig. 2: Service pages with optional interface design

Tab. 3: XV-102-L-57-.. device versions for front installation



Fig. 3: Front with plastic bezel

Fig. 4: Service side with optional interfaces

Tab. 4: XV-102-L-70-.. device versions for front installation



Fig. 5: Front with plastic bezel

Fig. 6: Service side with optional interfaces

1.4 Operating and indication elements

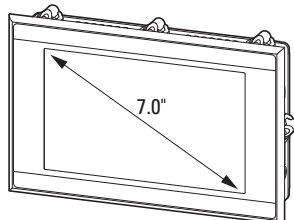
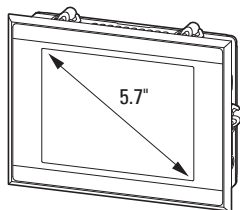
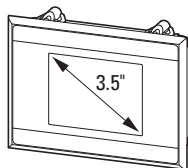

Touch sensor

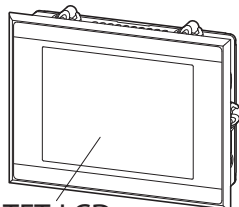

TFT-LCD

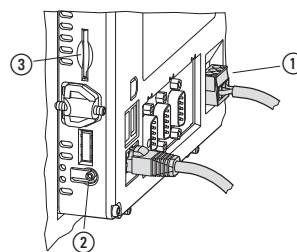
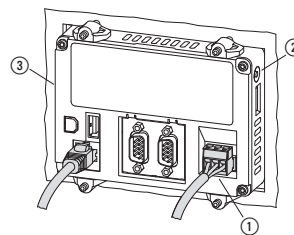

① Power connector

② CTRL button

③ SD card slot

Resistive touch display

Display of HMI device

Detection of the actuation of the operating elements shown on the display. These devices are operated by touching the operating elements with your finger or with a stylus.

The specific function depends on the software being used

Slot for SD card

## 1. Description

### 1.5 Interfaces to peripheral devices

#### 1.5 Interfaces to peripheral devices

The interfaces featured by your XV-102-L-... touchdisplay will depend on the XV-102 version selected and cannot be modified.

The nameplate will indicate which specific interfaces are included with the unit.

Basic interfaces (found on all XV-102)

	<b>Interface</b>	<b>Version</b>
④	Ethernet 1	RJ-45 socket, 8-pole, 2 LEDs (CAT5e/6), LAN1, 10/100 Mbps
⑤	USB host	USB 2.0, not galvanically isolated, plug type A, Full power (500 mA)

#### Equipment options

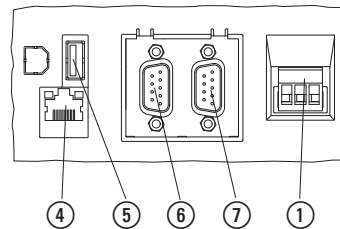

Fig. 7: Interfaces options 3.5" devices

	<b>Interface</b>	<b>Version</b>
⑥	RS-485 or RS-232*	SUB-D plug 9-pole, not galvanically isolated, UNC nuts for interlocking
⑧	CAN	SUB-D plug 9-pole, not galvanically isolated, UNC nuts for interlocking

\* depending on the device type

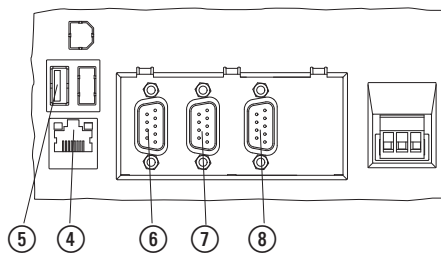

Fig. 8: Interfaces options 5.7"- and 7" devices

	<b>Interface</b>	<b>Version</b>
⑥	RS-485	SUB-D plug 9-pole, not galvanically isolated, UNC nuts for interlocking
⑦	CAN	SUB-D plug 9-pole, not galvanically isolated, UNC nuts for interlocking
⑧	RS-232	SUB-D plug 9-pole, not galvanically isolated, UNC nuts for interlocking

#### See also

→ Section "External connections", page 48

1.6 What the different parts of the part number mean

1.6 What the different parts of the part number mean

The part number includes information that specifies the version and model of the specific device being used.

The nameplate on your XV-102-L-... touchdisplay will show the corresponding part number.

Tab. 5: Part number

XV	-	102	-	L.	-	..	-	..
				Interfaces		Display		Version

Tab. 6: Interfaces

..	
L0	Ethernet 100/10;USB host
L3	Ethernet 100/10;USB host;RS-232
L4	Ethernet 100/10;USB host;RS-485
L5	Ethernet 100/10;USB host;RS-232;CAN
L6	Ethernet 100/10;USB host;RS-485;CAN

Tab. 7: Display

..	
35TQR	3.5" screen diagonal, QVGA (320 x 240 Pixel)
35TQRC	3.5" screen diagonal, QVGA (320 x 240 Pixel), CODESYS-license
57TVR	5.7" screen diagonal, VGA (640 x 480 Pixel)
57TVRC	5.7" screen diagonal, VGA (640 x 480 Pixel), CODESYS license
70TWR	7.0" screen diagonal, WVGA (800 x 480 Pixel)
70TWRC	7.0" screen diagonal, WVGA (800 x 480 Pixel), CODESYS-license

Tab. 8: Version

...	
10	Standard version
1E4	Version for the easyE4 control relays

XV-102 devices are available with various bundle options that include visualization software licenses and/or control software licenses. For further information and/or to order, please contact your supplier or use the EATON online catalogue.

Enter "XC-102" into the search box and the catalog will take you directly to the corresponding product group in the Automation, Control and visualization section.

 [Eaton.com/ecat](http://Eaton.com/ecat)

## 1. Description

### 1.7 Accessory devices

#### 1.7 Accessory devices

A variety of accessories are available for XV-102-L-... touchdisplays.

- SD card
- Accessories

**NOTICE**

Only use original accessories.



Order accessories through your supplier or through the EATON online catalog [Eaton.eu/ecat](https://Eaton.eu/ecat)

Example:

article no.	Catalog number
181638	MEMORY-SD-A2-S SD memory card with min. 1 GB
181637	ACCESSORIES-TP-10-KG brackets
139808	ACCESSORIES-TP-PEN-10

## **1.8 Nameplate**

The device has a nameplate on rear.

This nameplate includes the following information:

- Manufacturer
- Part number
- Part-No.
- EPAS code (digital nameplate)
- Version
- Date of manufacture
- Required power supply
- Serial-No.
- Type approval and certification marks and information
- Layout of ports/interfaces and controls
- Permissible mounting options (top edge «Top»)

## **1.9 Support**

To get fast and effective support, make sure to always provide Customer Service with the following information from the nameplate:

- Part-No.
- Serial-No

## 1. Description

### 1.10 Conditions for Underwriters Laboratories Inc. (UL) listing

#### 1.10 Conditions for Underwriters Laboratories Inc. (UL) listing



The following conditions must be met in order for the certification of UL508 as per XV-102 to apply:

Ambient temperature 0°C (32°F) to 50°C (122°F)

Mounting height up to 2000 m

Oversvoltage category II

Pollution Degree 2

Permissible voltage range 20%/+25% of rated operating voltage

Type rating

Use in type 4X or type 12 enclosures, use indoors only, at dry locations only

Maximum relative humidity of 95% for temperatures of up to 50 °C (122°F), derated linearly to a relative humidity of 50% at 40 °C (104°F).

Suitable power supply for class III (SELV or PELV)

The devices must be installed in a suitable fire protection enclosure that provides protection against the spread of fire.

The torque used to tighten the screw terminals on the plug-in connection for the supply voltage must not exceed 0.6 ... 0.8 Nm (5 ... 7 lb-in).

## 1.11 Marine approvals

### Type approval received



XV-102-L-... touchdisplay have been granted the required shipping classification by Det Norsk Veritas / Germanischer Lloyd (DNV GL)

- DNVGL-CG-0339 type approval, November 2015 edition, "Environmental test specification for electrical, electronic and programmable equipment and systems"  
Certificate No.: DNV GL Type Approval Certificate No: TAA00000NC

### Location classes

Temperature	B - Ambient temperature: 0°C (32°F) to +55°C (131°F)
Humidity	B - Relative humidity up to 100 % at all relevant temperatures.
Vibration	A - Bulkheads, beams, deck, bridge, acceleration amplitude: 0.7 g
EMC	B* - All locations (including bridge and open deck)
Input	Required protection according to DNV-GL Rules shall be provided upon installation on board

\* Filters / Ferrites maybe required to fulfil. See installation restrictions

### Installation restrictions

1. Install and commission referring to manuals.
2. Screened communication cables improve EMC behavior
3. PE connection of communication cables improve EMC behavior (e.g. earth-connection kit: EATON ZB4-102-KS1)

Location class	interface	Installation
----------------	-----------	--------------

EMC B	Power supply	Place noise filter
	Ethernet, RS-485, RS-232	Place the ferrite core or snap-together ferrites at a max. distance of 20 cm from the external device plug.

 **Please refer to the following as well** → Section "Conditions for marine approval", page 35

## 2. Safety regulations

### 2.1 Basics

## 2. Safety regulations

### 2.1 Basics

The device has been designed according to the state of the art and all generally accepted safety rules and standards. However, this alone cannot eliminate all potential hazards, which is why it is necessary for you to be aware of all hazards and residual risks.

Do not run the device unless it is in perfect technical condition. Make sure to always operate it as specified in this document and for the intended purpose.



**Follow the safety instructions for the XV-102!**

The section on safety instructions must be read and understood by everyone who will be working with the XV-102-L-... touchdisplay before the actual work is performed XV-102.

***NOTICE***

Pay attention to the hazard severity levels used throughout this documentation whenever a hazard is indicated. The hazard symbol and signal word used and the corresponding text will provide information regarding the specific hazard and how to avoid or prevent it.

## 2.2 Mandatory requirements, personnel requirements

### 2.2.1 Occupational safety

All generally accepted occupational health and safety rules and standards (internal and national) must be complied with, as must be all applicable laws and regulations in the relevant country.

### 2.2.2 Personnel qualifications

The personnel responsible for installation, operation, maintenance, and repairs must have the necessary qualifications for the work they will be performing. They must be appropriately trained and/or briefed and be informed of all hazards and risks associated with the device.

### 2.2.3 Device documentation

This manual is considered an integral part of the XV-102-L-... touchdisplay and must always be readily available in the device's close proximity so that users have access to it.

Make sure that every person who works with the XV-102 in any phase of the XV-102-L-... touchdisplay's life has read and understood the relevant parts of the XV-102 documentation.

Additional parts of the documentation and information for the XV-102, including the installation instructions, can be found at the Eaton Download Center and at the product pages on the Internet

 [Eaton.com/documentation](https://www.eaton.com/documentation)

 [Eaton.com/xv100](https://www.eaton.com/xv100)



#### **WARNING**

##### **Incomplete operator manual copies**

Working with individual pages taken out from the operator manual may lead to bodily injury and property damage due to missing safety information.

▶ Always work with the latest and full document.

## 2. Safety regulations

### 2.2 Mandatory requirements, personnel requirements

#### 2.2.4 Installation, maintenance, and disposal

Make sure that the XV-102 is connected, installed, serviced, and disposed of professionally and in line with all relevant standards and safety rules.



#### **CAUTION**

Installation requires qualified electrician



#### **Important!**

Dispose of recyclables as required by your local recycling regulations.

XV-102-L-... touchdisplay no longer being used must be professionally disposed of as per local standards or returned to the manufacturer or relevant sales department.

#### 2.2.5 Prerequisites for proper operation

In order for the device to be able to meet the contractually stipulated terms, the following must be observed:

- Only qualified personnel should be allowed to work with the XV-102.
- The personnel working with the XV-102 must have read the manual and must follow all the instructions in it.
- The required ambient conditions must be met.
- Maintenance work must be carried out correctly.



Make sure to read the → "Legal disclaimer", Seite 9.

We assume no liability for damages, consequential damages, and/or accidents caused by the following:

- Failure to follow any applicable occupational health and safety rules, standards, and/or regulations
- Device failures or function disturbances
- Improper use and/or handling
- Not following the instructions or observing the information in the documentation for the XV-102
- Alterations, changes, and repairs to the XV-102

## 2.3 Device-specific hazards



### **EXPLOSION HAZARD**

Death, serious injury, and property damage may occur if the device is being used in a potentially explosive (classified) location and, during operation, an electrical plug-in connection is disconnected or the device is exposed to dangerous impacts or other types of dangerous mechanical shock.

- ▶ Use the device in the following environments only:
  - Non-hazardous (non-explosive) areas
  - Zone 22 hazardous areas (as defined in the ATEX Directive)
- ▶ Make sure that the device is not exposed to dangerous impacts and other types of dangerous mechanical shock.
- ▶ Make sure to avoid any bunch discharge.
- ▶ Do not operate the device in hazardous (classified) locations unless it is mounted correctly.
- ▶ De-energize the device before disconnecting plug connections.



### **EXPLOSION HAZARD**

#### **LITHIUM BATTERY**

The lithium battery inside the XV-102-L-... touchdisplay may explode if handled incorrectly.

- ▶ Dispose of the XV-102 unit professionally.



### **CAUTION DESTRUCTION**

The XV-102-L-... touchdisplay should only be opened by the manufacturer or by an authorized center. Operate the XV-102 until only with the enclosure fully closed and sealed.

## 2. Safety regulations

### 2.3 Device-specific hazards



#### **CAUTION** **ELECTROSTATIC DISCHARGE**

Do not touch components (e.g., connector pins) that are electrostatic-sensitive.

- ▶ Discharge any static electricity from your body before touching the HMI-PLC (e.g., by touching an earthed metal object).

Electrostatic discharges may damage or ruin assembly parts.

Because of this, it is necessary to take precautions whenever handling the cards.

Please refer to the guidelines for electrostatic-sensitive components for more information (ESD guidelines).



#### **CAUTION** **INTERFERENCES**

The values specified in the technical data, as well as the device's electromagnetic compatibility (EMC), cannot be guaranteed if the following are used: unsuitable cables, improperly assembled and terminated cables, and/or wiring that does not conform to the applicable standards.

Only use cables assembled and terminated by professionals.

The cables being used must be assembled and terminated as required by the port/interface description in this document.

When wiring the XV-102-L-... touchdisplay, follow all instructions regarding how to wire the corresponding port/interface.

All general Directives and standards must be complied with.



#### **CAUTION** **INTERFERENCES**

Screw all plug-in connections or lock them into place in order to improve screening.

Signal cables must not be routed in the same cable duct with power cables.

Before putting the system into operation, check all cable connections to make sure that everything has been wired properly.

Make sure that all voltages and signals have the required values as specified in the technical data.



#### **CAUTION** **SAFELY DIVERTING ELECTRICAL INTERFERENCE CURRENTS**

The XV-102-L-... touchdisplay must be connected to a central earth point with a conductor that is as short and has as low a resistance as possible.

## 2. Safety regulations

### 2.3 Device-specific hazards



#### **DANGER** **STRAY CURRENTS**

Large equalizing currents between the functional earthing system and the ground system of different devices may result in fire or in malfunctions due to signal interference.

- ▶ If necessary, route an equipotential bonding conductor, with a cross-sectional area that is several times larger than that of the cable shielding, parallel to the cable.



#### **CAUTION** **NON-GALVANICALLY-ISOLATED INTERFACES**

The XV-102-L-... touchdisplay may be damaged by potential differences.

- ▶ The GND terminals of all bus modules must be connected.
- ▶ Do not connect the connector to the XV-102 or disconnect it without first de-energizing the system.



#### **CAUTION** **DATA LOSS**

Avoid frequent write operations to the device's internal memory and/or the SD card and/or the USB flash drive, as:

- The number of write cycles of the device's internal memory, SD cards and USB memory is limited.
- If there is a voltage drop while a write operation is in progress, data loss is highly likely to occur.



#### **CAUTION** **DATA LOSS**

- ▶ Insert or remove the SD card only when the XV-102-L-... touchdisplay is de-energized.
- ▶ Before switching off the device, make sure that there are no programs writing to the SD card.



#### **CAUTION** **SHORT-CIRCUIT HAZARD**

If the XV-102-L-... touchdisplay is or has been exposed to environmental fluctuations (ambient temperature, air humidity), condensation may form on or inside XV-102. As long as this condensation is present, there will be a short-circuit hazard.

## 2. Safety regulations

### 2.3 Device-specific hazards

Do not switch on the XV-102-L-... touchdisplay when it has condensation in or on it.

If the XV-102-L-... touchdisplay has condensation in or on it, or if it has been exposed to environmental fluctuations, let the device settle into the existing ambient temperature before switching it on. Do not expose the XV-102-L-... touchdisplay to direct thermal radiation from heating appliances.



#### **CAUTION UV LIGHT**

Plastics will become brittle when exposed to UV light. This artificial aging will reduce the XV-102-L-... touchdisplay unit's lifespan. Protect the XV-102 unit from direct sunlight and other sources of UV radiation.



#### **CAUTION POINTY, SHARP OBJECTS AND CORROSIVE LIQUIDS**

When cleaning the XV-102-L-... touchdisplay:

- Do not use any pointy or sharp objects (e.g., knives).
- Do not use aggressive or abrasive cleaning products or solvents.

Make sure that no liquids get into the XV-102-L-... touchdisplay unit (short-circuit hazard) and that the XV-102-L-... touchdisplay unit is not damaged in any way.



#### **CAUTION SENSITIVE RESISTIVE TOUCH SURFACE**

Damage to the resistive touch due to the use of pointed or sharp objects.

- Only activate the resistive touch with your finger or a stylus.

When wearing gloves, ensure that these are clean, and free of abrasive dust and particles.

## 2. Safety regulations

### 2.3 Device-specific hazards



#### **CAUTION** **INSTALLATION CUT-OUT**

The mounting cutout must be located in a position that will not defeat the purpose of stabilizing webs or other reinforcing elements in the control panel. If necessary, reinforcing elements must be installed/added.

An IP65, Nema 4x and Nema 12 degrees of protection will only be ensured if there is sufficient stiffness, the device is properly mounted using the original fixing material, and the gasket has a proper seat

- Minimum sheet thickness of control panel panel where the device will be flush mounted:  
 $2 \text{ mm (0.08")} \leq d \leq 5 \text{ mm (0.2")}$



#### **CAUTION**

When using commercially available peripheral devices (e.g., with the USB port), it is important to keep in mind that their EMC interference immunity parameters may render them unsuitable for use in industrial environments.

The USB ports on the XV-102-L-... touchdisplay are intended exclusively for maintenance work.



#### **WARNING**

The device should only be run with safety extra-low voltage (functional extra-low voltage with protective separation).

The power transformer must conform to the relevant standards.



#### **CAUTION** **FORCES ON THE ETHERNET INTERFACE**

Communications may be affected, and the connection's mechanical components may be damaged, if the Ethernet interface is subjected to strong vibrations or the RJ45 plug-in connection is subjected to pulling.

- Protect the RJ45 plug-in connection from strong vibrations.
- Protect the RJ45 plug-in connection from tensile forces at the socket.



#### **CAUTION**

Installation requires qualified electrician

## 3. Installation

### 3.1 Prerequisites for the location of use

## 3. Installation

### 3.1 Prerequisites for the location of use

The XV-102 must be used exclusively in locations for which XV-102-L-... touchdisplay has been approved/certified.

A 24 VDC supply voltage must be ensured as per the specifications.

 **See also** Label on the → "Nameplate", Seite 20  
as well as the specifications in the appendix → Section "Technical data", page 66

#### 3.1.1 Installation position

The following must be taken into account when selecting the installation position:

- If you will be using the XV-102-L-... touchdisplay in a hazardous (explosive) location, make sure it is not exposed to any dangerous impacts or other types of dangerous mechanical shock.
- The controls and connectors on the XV device's service side must remain accessible even after the device has been installed.



The SD card slot is located on the side of the XV-102.  
Make sure to take the space required to remove the SD card into account.

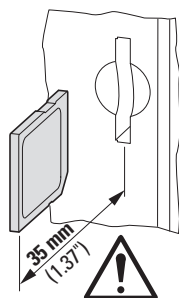

Fig. 9: Space required to remove the SD card

3.1 Prerequisites for the location of use

3.1.1.1 Temperatures

Make sure that the XV-102 does not overheat.

Do not expose the XV-102 to direct sunlight or other sources of heat.

The minimum clearance to components emitting heat, such as transformers under heavy loads, is 15 cm.



**CAUTION  
UV LIGHT**

Plastics will become brittle when exposed to UV light. This artificial aging will reduce the XV-102-L-... touchdisplay unit's lifespan. Protect the XV-102 unit from direct sunlight and other sources of UV radiation.

The environmental ambient conditions for operation must not exceed the specified values:

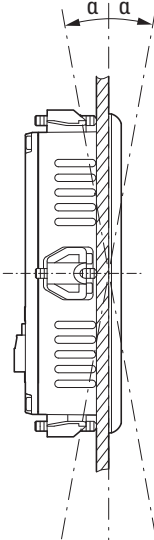
Ambient climatic conditions	
Air pressure (in operation)	795 - 1080 hPa Max. 2000 m above sea level
Temperature	<p>Operation <math>0^{\circ}\text{C} (32^{\circ}\text{F}) \leq T \leq 50^{\circ}\text{C} (122^{\circ}\text{F})</math></p> <p>Inclination</p>  <p>Inclination from vertical: <math>\alpha \leq 45^{\circ}</math> at operating temperature <math>\leq 50^{\circ}\text{C} (122^{\circ}\text{F})</math> possible (if using natural convection)</p>
Storage / Transport	$-20 - +60^{\circ}\text{C} (-4 - +140^{\circ}\text{F})$
Humidity	Relative humidity 10 - 95 %
Condensation	non-condensing

### 3. Installation

#### 3.1 Prerequisites for the location of use

##### 3.1.1.2 Aeration and de-aeration

- Do not block the ventilation openings when mounting the device:  
They are designed to allow air to circulate in order to cool the HMI-PLC.
- The device uses natural convection-based passive cooling, i.e., it does not use fans.

Ventilation diagram

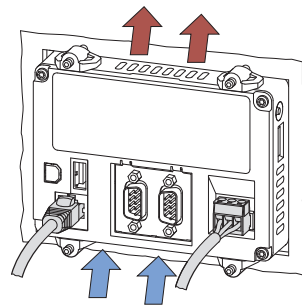

Fig. 10: Cooling air circulation

Clear Zone

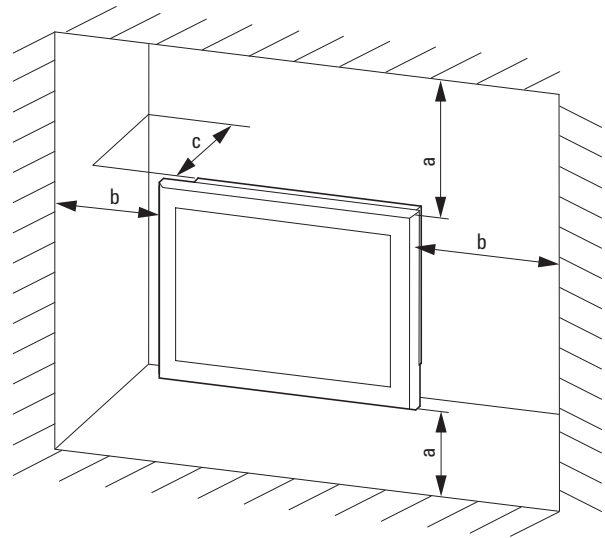

Fig. 11: Mounting distance

- Make sure that there will be enough volume for air changes inside the control panel, etc.  
The specified clearance around the XV-102-L-... touchdisplay is:  $a, b, c \geq 30 \text{ mm}$  (1.18")
- If you will be installing the XV-102-L-... touchdisplay in complex systems together with other assemblies, you must ensure that there will be enough air circulation in order to prevent overheating.  
Ambient temperature with natural convection:  $9 \text{ }^{\circ}\text{C}$  (32°F)  $\leq T \leq 50 \text{ }^{\circ}\text{C}$  (122°F)  
The panel builder is responsible for the temperature rise calculation. Eaton will provide heat dissipation data for the XV-102-L-... touchdisplay as necessary for design verification in accordance with IEC EN 61439.

### 3. Installation

#### 3.1 Prerequisites for the location of use

##### 3.1.2 Technical conditions for acceptance by Underwriters Laboratories Inc. (UL)



The following conditions must be met in order for the certification of UL508 as per XV to apply:

Ambient temperature 0°C (32°F) to 50°C (122°F)

Mounting height up to 2000 m

Overvoltage category II

Pollution Degree 2

Permissible voltage range 20%/+25% of rated operating voltage

Type rating

Use in type 4X or type 12 enclosures, use indoors only, at dry locations only

Maximum relative humidity of 95% for temperatures of up to 50 °C (122°F), derated linearly to a relative humidity of 50% at 40 °C (104°F).

Suitable power supply for class III (SELV or PELV)

The devices must be installed in a suitable fire protection enclosure that provides protection against the spread of fire.

The torque used to tighten the screw terminals on the plug-in connection for the supply voltage must not exceed 0.6 ... 0.8 Nm (5 ... 7 lb-in).

### 3. Installation

#### 3.1 Prerequisites for the location of use

##### 3.1.3 Conditions for marine approval



The following DNV GL rules for shipping classification in accordance with DNVGL-CG-0339 type approvals must be observed:

1. Complete and proper installation and commissioning in accordance with DNV GL rules and Eaton requirements and specifications.
2. Installation of radio interference suppression filters for the 24 V DC supply.

**3.1.3.1 Radio interference suppression filter for the 24-V-DC-supply**

Additional interference filters must be installed for the power supply in order to adhere to the EMC B provisions.

- ▶ Integrate a radio interference suppression filter into the wiring.

Depending on the output, the following filters can be used:

- XT-FIL-1 radio interference suppression filter for 24 V DC supply up to 2.2 A (Eaton article no. 285316)

or

- XT-FIL-2 radio interference suppression filter for 24 V DC supply up to 12 A (Eaton article no. 118980)

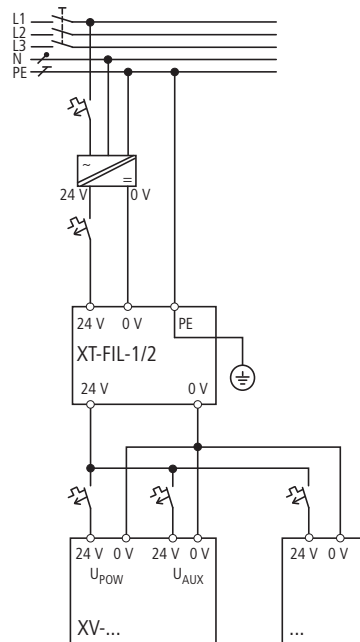

Fig. 12: Engineering example for integration of radio interference suppression filters

Earthing is ensured either by using

- the filter's integrated contact fields onto a grounded metal plate
- or using
- a separate line to the filter's PE connection.

Depending on the current consumption or configuration, several filters may be used as well.

### 3. Installation

#### 3.2 Unpacking and checking the equipment supplied

#### 3.2 Unpacking and checking the equipment supplied



- ▶ Check the HMI-PLC's packaging for transit damage.
- ▶ Carefully remove the packaging in order to avoid damaging the device.
- ▶ Check the package contents for visible transit damage.
- ▶ Use the information in Installation instructions IL048021ZU to make sure that the contents are complete.



Keep the original packaging so that you will be able to use it in the future if you need to transport or ship the HMI-PLC. Make sure to also keep the documents enclosed with the device and/or to give them to the end customer.

The package for the XV-102-L-... touchdisplay comes with:

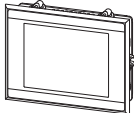
Tab. 9: Std. pack

Unit	Description
1 x 	XV-102-L-... touchdisplay
1 x 	Plug connector MSTB 2.5/3-ST-5.08
1 x	Installation instructions IL048021ZU
4 x / 6 x / 8 x	Holding bracket with set screw Internal hexagon M 4 x 25 DIN 914 galvanized 4 x for XV-102-L.-35-... , 6 x for XV-102-L.-57-... , or 8 x for XV-102-L.-70-..

The XV-102-L-... touchdisplay is sturdily built, but the components inside it are sensitive to excessively strong vibrations and/or mechanical shock.

Accordingly, make sure to protect the XV-102-L-... touchdisplay from mechanical loads that exceed the scope of the unit's intended use.

The XV-102 should only be transported in its original packaging after being packed properly.

#### Missing parts or damage

If you notice anything wrong, please contact your distributor or Eaton Service +49 (0) 180 5 223822 (de,en)

### 3.3 Mounting

**NOTICE**

Arrange for a professional technician to mount the device.



**CAUTION**  
**INSTALLATION CUT-OUT**

The mounting cutout must be located in a position that will not defeat the purpose of stabilizing webs or other reinforcing elements in the control panel. If necessary, reinforcing elements must be installed/added.

An IP65, Nema 4x and Nema 12 degrees of protection will only be ensured if there is sufficient stiffness, the device is properly mounted using the original fixing material, and the gasket has a proper seat

- Minimum sheet thickness of control panel where the device will be flush mounted:  
 $2 \text{ mm (0.08")} \leq d \leq 5 \text{ mm (0.2")}$

### 3.4 Preparations

#### Front mounting XV-102 with mounting by Holding bracket with set screw

**List of tools:**

- 2.0 m Allen key
  - PZ2 Pozidriv screwdriver
  - Torque wrench with Newton meter scale
1. Select the installation location you want for the device.  
Make sure that all the requirements for the installation location are met → Section "Prerequisites for the location of use", page 31.
  2. Make a cutout with the right size for the device at the location you selected.  
Make sure to observe all the criteria for the installation location.
  3. Make sure that the mounting cutout has the right size.

### 3. Installation

#### 3.4 Preparations

##### 3.4.0.1 Criteria for the Installation position

The XV-102 are intended to be flush mounted in control cabinets, control panels, or control consoles.

- The XV-102-L-... touchdisplay can be installed in landscape or portrait mode.
- If you are using your XV-102-L-... touchdisplay unit with an SD card, do not install it with the SD slot facing downwards, as the SD card may fall out otherwise.
- The enclosure material must be thick enough,  
For front mounting:  $2 \text{ mm (0.08")} \leq d \leq 5 \text{ mm (0.2")}$ ,

Flatness  $\square \leq 0.5 \text{ mm (0.02")}$  at the mounting cutout with  $\nabla Rz \leq 120$ ; IP 65  $\rightarrow$  DIN ISO 2768-2 (K)

- Recommended mounting cutout  
for front mounting

XV-102-L.-35-...:  $e = 123 \text{ mm} \pm 1 (4.84" \pm 0.04)$ ,  $f = 87 \text{ mm} \pm 1 (3.43" \pm 0.04)$ ,

XV-102-L.-57-...:  $e = 157 \text{ mm} \pm 1 (6.18" \pm 0.04)$ ,  $f = 117 \text{ mm} \pm 1 (4.61" \pm 0.04)$ ,

XV-102-L.-70-...:  $e = 197 \text{ mm} \pm 1 (7.76" \pm 0.04)$ ,  $f = 122 \text{ mm} \pm 1 (4.80" \pm 0.04)$

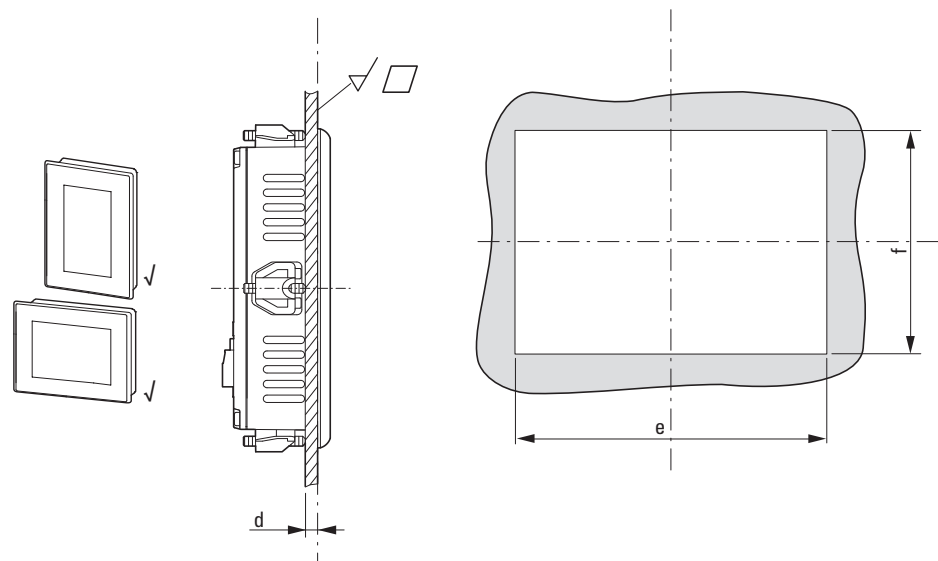

Fig. 13: flush mounted

4. Check that the gasket is resting properly inside the groove and will provide the required sealing action

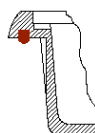

Fig. 14: Peripheral gasket at the back of the front frame on the housing

5. Pre-assemble the holding brackets with the set screws.  
Screw the Internal hexagon M 4 x 25 DIN 914 galvanized set screws into the holding brackets.

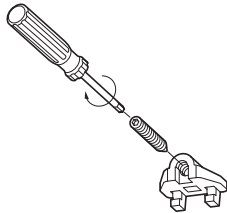

Fig. 15: Pre-installing the holding brackets

The required holding brackets are included in the right amount as accessories with the XV-102. All the included holding brackets need to be installed!

➔ Together with the gasket, the holding brackets are the main element required for achieving an IP65 (at front) degree of protection.

The purpose of the holding brackets is to secure the XV-102 in the installation cutout, e.g., on the control panel door.

To this end, the brackets must be hooked into the enclosure sideways and screwed against the control panel door, etc.

Make sure to position the holding brackets in such a way that they will push against the center of the peripheral gasket.

➔ The number and positions of the retaining brackets depend on the device type.

Tab. 10: Holding bracket with set screw Internal hexagon M 4 x 25 DIN 914 galvanized

4 x	for XV-102-L.-35-..
6 x	for XV-102-L.-57-..
8 x	for XV-102-L.-70-..

### 3. Installation

#### 3.5 XV-102 mounting

#### 3.5 XV-102 mounting

*Insert the holding brackets into the enclosure*

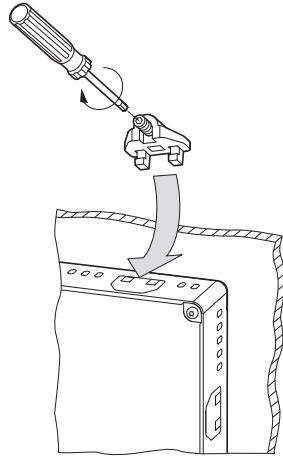

- ▶ 1. Insert the XV-102 into the mounting cutout.
- ▶ 2. Insert a holding bracket into the corresponding enclosure opening and tighten the set screw until it comes into contact with the surface of the control panel, etc.
- ▶ 3. Repeat on the opposite side.
- ▶ 4. Follow steps 3 and 4 to insert the next holding bracket at a 90° angle to the last one you inserted.
- ▶ 5. Repeat steps 3 and 4 until all holding brackets are installed.
- ▶ 6. Check that the device is in its correct, centered position and that the gasket is in contact all around; adjust if necessary.
- ▶ 7. Tighten the set screws in a criss-cross sequence:  
with a torque of  $\leq 0.1\text{Nm}$  (0.86 lb-in)

### 3.6 Preparing the device for operation



**CAUTION**  
**INTERFERENCES**

Screw all plug-in connections or lock them into place in order to improve screening.

Signal cables must not be routed in the same cable duct with power cables.

Before putting the system into operation, check all cable connections to make sure that everything has been wired properly.

Make sure that all voltages and signals have the required values as specified in the technical data.



**CAUTION**  
**SHORT-CIRCUIT HAZARD**

If the XV-102-L-... touchdisplay is or has been exposed to environmental fluctuations (ambient temperature, air humidity), condensation may form on or inside XV-102. As long as this condensation is present, there will be a short-circuit hazard.

Do not switch on the XV-102-L-... touchdisplay when it has condensation in or on it.

If the XV-102-L-... touchdisplay has condensation in or on it, or if it has been exposed to environmental fluctuations, let the device settle into the existing ambient temperature before switching it on. Do not expose the XV-102-L-... touchdisplay to direct thermal radiation from heating appliances.

#### Before connecting the power supply



**CAUTION**

The voltage being applied must meet the requirements for safety extra-low voltages (SELV) set forth in IEC 60950 and the requirements for protected extra-low voltages (PELV) set forth in ICE/UL 61010-2-201.

Pay attention to the polarity („+“ and „-“)!

**NOTICE**

Arrange for an electrician to install the Plug connector MSTB 2.5/3-ST-5.08 and connect the power supply.

The XV-102-L-... touchdisplay has an internal fuse and protection against polarity reversal.

The power supply for the XV-102-L-... touchdisplay is not galvanically isolated.

### 3. Installation

#### 3.6 Preparing the device for operation

The XV-102-L-... touchdisplay requires a rated operating voltage of 24 VDC from an AC-to-DC converter with safe isolation (SELV/PELV).

Power Supply			
rated operating voltage	+ 24 VDC SELV (safety extra low voltage)/PELV (protective extra low voltage)		
permissible voltage range	Effective: 19.2-30.0 V DC (rated operating voltage -20%/+25%)		
	Absolute with ripple: 18.0-31.2 V DC		
	Battery powered: 18.0-31.2 V DC (rated operating voltage -25%/+30%); 35 V DC for a duration of < 100 ms		
Voltage dips	Ability to accommodate brief voltage dips ≤ 10 ms, in accordance with IEC61131-2		
Power consumption			
XV-102-L-35-..	max. 5 W Current consumption at 24 V DC: 5 W for basic device + 2.5 W for USB module		
XV-102-L-57-.., XV-102-L-70-..	max. 7 W Current consumption at 24 V DC: 7 W for basic device + 2.5 W for USB module		
fuse	Yes (fuse not accessible)		
Potential isolation	no		
Protection against polarity reversal	Yes		
Electrical current	3.5" display	5.7" display	7.0" display
$I_e$	≤ 0.3 A	≤ 0.4 A	≤ 0.4 A
$I_{TH}$	1.0 A <sup>2</sup> s		
Starting current inrush	1.5 A <sup>2</sup> s		

##### 3.6.1 Functional earthing XV-102-L-... touchdisplay

The device has an internal fuse and protection against polarity reversal.  
 The functional earth is connected to the connector cover only, and not to 0 V.  
 The housing is made of plastic and is potential-free.  
 The device's power supply is **not** galvanically isolated.

### 3. Installation

#### 3.6 Preparing the device for operation

#### 3.6.2 Power supply - electrical connection

Tab. 11: Configuration Plug connector MSTB 2.5/3-ST-5.08

signal	Configuration
+	Specifications for connection to supply voltage + 24 VDC SELV (safety extra low voltage)/PELV (protective extra low voltage)
⊕	Functional earth connected to connector cover. If required due to the installation environment, this connection can be used as a protective earth connection.
-	Supply voltage 0 V

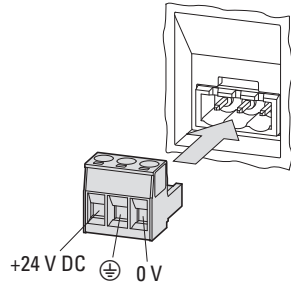

Tab. 12: Specifications for connection to 24 VDC supply voltage

Specifications for connection to 24 VDC supply voltage	
Copper conductor	60° (140°F)/ 70°C (158°F)
Cross-section	min. 0.75 mm <sup>2</sup> / max. 2.5 mm <sup>2</sup> (drain wire or conductor) min. AWG18 / max. AWG12
Tightening torque	0.6 ... 0.8 Nm (5 ... 7 lb-in) for the screws on the Plug connector MSTB 2.5/3-ST-5.08
Strip length	7 mm

#### Power supply

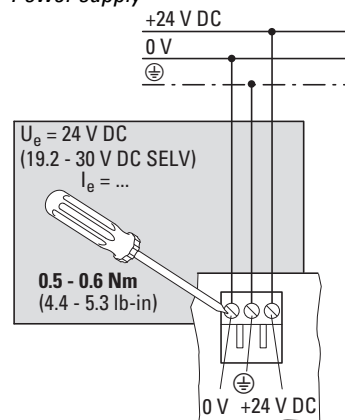

Fig. 16: Connecting the screw terminals on the Plug connector MSTB 2.5/3-ST-5.08

- ▶ Use the Plug connector MSTB 2.5/3-ST-5.08 to terminate the connection cable for the power supply in advance.
- ▶ Plug the pre-assembled plug into the socket on the enclosure.
- ▶ Pay attention to the polarity.
- ▶ Connect the power supply cable to a 24 VDC supply voltage that meets the requirements for safety extra-low voltages (SELV) set forth in IEC 60950 and – in connection with the UL listing – the requirements for a low-voltage source set forth in UL508.

The XV-102-L-... touchdisplay is now ready to run on 24 V<sub>DC</sub>.

## 4. Commissioning

### 4.1 Initial commissioning

## 4. Commissioning



#### **CAUTION** **SHORT-CIRCUIT HAZARD**

If the XV-102-L-... touchdisplay is or has been exposed to environmental fluctuations (ambient temperature, air humidity), condensation may form on or inside XV-102. As long as this condensation is present, there will be a short-circuit hazard. Do not switch on the XV-102-L-... touchdisplay when it has condensation in or on it.

If the XV-102-L-... touchdisplay has condensation in or on it, or if it has been exposed to environmental fluctuations, let the device settle into the existing ambient temperature before switching it on. Do not expose the XV-102-L-... touchdisplay to direct thermal radiation from heating appliances.

- ▶ Apply a XV-102 to the 24 VDC supply voltage unit

The XV-102 unit will boot up.



The XV-102-L-... touchdisplay does not come with any runtime software for visualization or PLCs installed. The corresponding software packages can be used to install the required runtime software on the XV-102 unit.

### 4.1 Initial commissioning

Carry out the following steps once:

- ▶ Configure the XV-102 unit's system settings as necessary.
- ▶ Install the required software packages.

#### **See also**



[System description for embedded Linux](#)

MN050017EN

## 4.2 Running the XV-102

Once the XV-102-L-... touchdisplay has been initially commissioned, it will run whenever it is connected to the supply voltage.

In other words, it does not have to be separately switched on and off.

→ The device does not have an ON/OFF switch. The device is not provided with an On/Off switch. If the power supply is not provided with a switch, the device will start up (boot) as soon as it is connected to the power supply.

→ Reducing the level of brightness will increase the display backlight's lifespan.

→ Follow the instructions in the following section if your XV-102 until will not boot up and/or if an error message appears: → Section "Faults", page 59

### 4.2.1 Display Characteristics of TFT Displays (Image Retention / Ghosting)

With touch panels using TFT displays, the long-term display of unchanged, static or high-contrast screen content may lead to so called image retention effects (ghosting).

These effects may cause previously displayed screen content to remain faintly visible after the display content has changed. The intensity and duration of such residual images depends on several factors including the display duration, brightness, contrast, and the type of displayed content.

With very long display times, the effect may persist over an extended period; in rare cases, permanent visibility cannot be completely ruled out.

Generally, existing residual images fade automatically when the display is switched off for a certain time or operated with changing screen content.

Image retention effects are a technology related characteristic of TFT displays and do not indicate a malfunction of the device.

### 4.2.2 Notes on Visualization Project Design

To reduce or avoid image retention effects, the following measures are recommended when designing the visualization:

- Avoid permanently static screen content
- Change frequently displayed screens at regular intervals, for example by using periodic screen changes or dynamic display elements
- Provide screen savers or inactive screens, preferably with a dark or black display when the backlight is active

## 4. Commissioning

### 4.2 Running the XV-102

- Adjust brightness and contrast according to application requirements
- Automatically switch off the backlight during periods of inactivity, if supported by the target system
- Use blinking or high contrast display elements only in a targeted manner and for limited periods of time

### 5. External connections

With their ports, Eaton's XV-102-L-... touchdisplay make it possible to connect a variety of peripheral devices and components.



#### **DANGER STRAY CURRENTS**

Large equalizing currents between the functional earthing system and the ground system of different devices may result in fire or in malfunctions due to signal interference.

- ▶ If necessary, route an equipotential bonding conductor, with a cross-sectional area that is several times larger than that of the cable shielding, parallel to the cable.



#### **CAUTION INTERFERENCES**

The values specified in the technical data, as well as the device's electromagnetic compatibility (EMC), cannot be guaranteed if the following are used: unsuitable cables, improperly assembled and terminated cables, and/or wiring that does not conform to the applicable standards.

Only use cables assembled and terminated by professionals.

The cables being used must be assembled and terminated as required by the port/interface description in this document.

When wiring the XV-102-L-... touchdisplay, follow all instructions regarding how to wire the corresponding port/interface.

All general Directives and standards must be complied with.

## 5. External connections

### 5.1 Layout of interfaces

#### 5.1 Layout of interfaces

The interfaces featured by your XV-102-L-... touchdisplay will depend on the XV-102 version selected and cannot be modified.

The nameplate will indicate which specific interfaces are included with the unit.

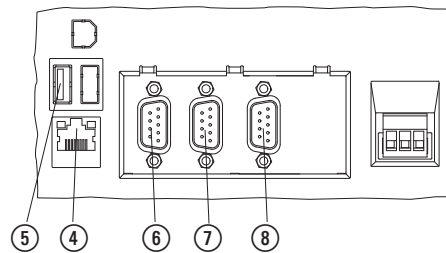

Fig. 17: Interfaces options 5.7" - and 7" devices

#### Interfaces included on all HMI-PLCs

Interface	Version
④ Ethernet 1	RJ-45 socket, 8-pole, 2 LEDs (CAT5e/6), LAN1, 10/100 Mbps
⑤ USB host	USB 2.0, not galvanically isolated, plug type A, Full power (500 mA)

#### 5.1.1 Optional interfaces

Interface	Version
⑥ RS-485	SUB-D plug 9-pole, not galvanically isolated, UNC nuts for interlocking
⑦ CAN	SUB-D plug 9-pole, not galvanically isolated, UNC nuts for interlocking
⑧ RS-232	SUB-D plug 9-pole, not galvanically isolated, UNC nuts for interlocking

## 5.2 SD card

The slot for the SD card is on the side of the XV-102-L-... touchdisplay unit.



**CAUTION  
DATA LOSS**

Avoid frequent write operations to the device's internal memory and/or the SD card and/or the USB flash drive, as:

- The number of write cycles of the device's internal memory, SD cards and USB memory is limited.
- If there is a voltage drop while a write operation is in progress, data loss is highly likely to occur.



**CAUTION  
DATA LOSS**

- ▶ Insert or remove the SD card only when the XV-102-L-... touchdisplay is de-energized.
- ▶ Before switching off the device, make sure that there are no programs writing to the SD card.

### Inserting the SD card



SD cards cannot be inserted the wrong way around.

Do not use force when inserting the card.

- ▶ Push the SD card into the SD card slot until you feel it lock into place.

### Removing the SD card

- ▶ Push the SD card into the SD card slot all the way to the stop.
- ▶ Pull the SD card out of the SD card slot.
- ▶ Store the SD card in its case in order to protect it.

## 5. External connections

### 5.3 USB interfaces

#### 5.3 USB interfaces

Eaton's XV-102-L-... touchdisplay units feature ports that can be used to connect USB peripheral devices supported by the XV-102 unit's hardware and operating system.



#### CAUTION

When using commercially available peripheral devices (e.g., with the USB port), it is important to keep in mind that their EMC interference immunity parameters may render them unsuitable for use in industrial environments.

The USB ports on the XV-102-L-... touchdisplay are intended exclusively for maintenance work.



#### CAUTION DATA LOSS

Avoid frequent write operations to the device's internal memory and/or the SD card and/or the USB flash drive, as:

- The number of write cycles of the device's internal memory, SD cards and USB memory is limited.
- If there is a voltage drop while a write operation is in progress, data loss is highly likely to occur.



Only use standard USB cables with a shield.  
Max. cable length: 5 m.

#### 5.3.1 USB host



Fig. 18: USB 2.0, not galvanically isolated, plug type A, Full power (500 mA)

## 5.4 Ethernet 1

The Ethernet 1 port on the XV-102-L-... touchdisplay can be used as a communication interface or as a real-time field bus interface.

The Ethernet controllers support transfer rates of 10 Mbit/s and 100 Mbit/s.

When the green LED lights up, this means that there is a LINK, i.e., that an active network is connected and has been detected.

When the yellow LED flashes, this means that data is being transferred.



Fig. 19: RJ-45 socket, 8-pole, 2 LEDs (CAT5e/6), LAN1, 10/100 Mbps



For the network, use shielded twisted-pair (STP) cables only.



### CAUTION

#### FORCES ON THE ETHERNET INTERFACE

Communications may be affected, and the connection's mechanical components may be damaged, if the Ethernet interface is subjected to strong vibrations or the RJ45 plug-in connection is subjected to pulling.

- Protect the RJ45 plug-in connection from strong vibrations.
- Protect the RJ45 plug-in connection from tensile forces at the socket.

To commission the communication between the XV-102 and the device, follow the description for the connected device.

## 5. External connections

### 5.5 Serial interfaces for communication with PLCs or devices

## 5.5 Serial interfaces for communication with PLCs or devices

### 5.5.1 COM1 RS-232

The RS232-The interface is not electrically isolated.



#### CAUTION

#### NON-GALVANICALLY-ISOLATED INTERFACES

The XV-102-L-... touchdisplay may be damaged by potential differences.

- ▶ The GND terminals of all bus modules must be connected.
- ▶ Do not connect the connector to the XV-102 or disconnect it without first de-energizing the system.

Tab. 13: Pin assignment RS-232

SUB-D plug 9-pole, not galvanically isolated, UNC nuts for interlocking

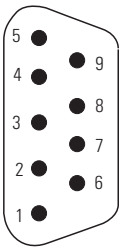
SUB-D plug	PIN	signal	Description
9 pole 	1	DCD	Data Carrier Detect
	2	RXD	Receive Data
	3	TXD	Transmit Data
	4	DTR	Data Terminal Ready
	5	GND	Signal Ground
	6	DSR	Data Set Ready
	7	RTS	Request to Send
	8	CTS	Clear To Send
	9	RI	Ring Indicator
	Plug housings	GND	Functional earth

#### 5.5.1.1 Wiring topic

- Shielded cables must be used.
- The maximal baud rate depends on the cable length

Tab. 14: RS-232 cable length based on baud rate

Cable length	Max. baud rate
2.5 m	115200 Bit/s
5 m	57600 Bit/s
10 m	38400 Bit/s
15 m	19200 Bit/s
30 m	9600 Bit/s



When preparing connections, ensure that the cable shield has a low impedance connection with the connector housing.

## 5. External connections

### 5.5 Serial interfaces for communication with PLCs or devices

#### 5.5.2 COM2 RS-485

The RS-485-The interface is not electrically isolated.



#### CAUTION

#### NON-GALVANICALLY-ISOLATED INTERFACES

The XV-102-L-... touchdisplay may be damaged by potential differences.

- ▶ The GND terminals of all bus modules must be connected.
- ▶ Do not connect the connector to the XV-102 or disconnect it without first de-energizing the system.

Tab. 15: Pin assignment RS-485

SUB-D plug 9-pole, not galvanically isolated, UNC nuts for interlocking

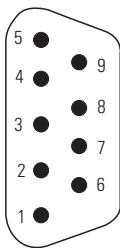
SUB-D plug	PIN	signal	Description
9 pole 	1	n.c.	not used
	2	n.c.	not used
	3	B	Line B
	4	n.c.	not used
	5	GND	Ground
	6	5 V	Output for external bus voltage
	7	A	A cable
	8	n.c.	not used
	9	n.c.	not used
Plug housings	GND	Functional earth	



n.c.: PIN 1, 2, 4, 8 and 9 must not be connected.



Pin 6 (5 V) must not be used as a power supply for external devices.

#### Wiring topic

- Screened twisted-pair cables must be used.
- The maximal baud rate depends on the cable length.

Tab. 16: Specifications for RS-485 wiring

Rated cable impedance	120 Ohm
Permissible impedance	108 ... 132 Ohm
Max. cable length	1200 m
Possible baud rates	9600 Bit/s
	19200 Bit/s
	38400 Bit/s
	57600 Bit/s
	115200 Bit/s



When preparing connections, ensure that the cable shield has a low impedance connection with the connector housing.

## 5. External connections

### 5.5 Serial interfaces for communication with PLCs or devices

#### RS-485 topology

- A bus segment can interconnect up to 32 slaves.
- Several bus segments can be connected using repeaters (bi-directional amplifiers).



The use of repeaters enables the maximum cable length to be increased.

For more details, please consult the documentation provided by manufacturer.

A bus segment must be provided with cable termination (120 Ohm) at both ends.

These terminals must be connected in the plug directly between pin 3 and 7.



The bus segment must be terminated at both ends.

There must not be more than two terminations per bus segment.

Running the bus segment without the right termination may result in transmission errors.

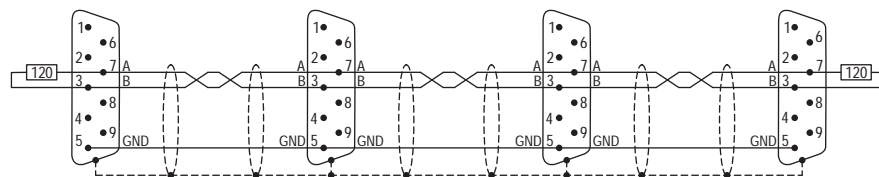



Fig. 20: Bus segment with four nodes

5.6 CAN interface for the CANopen protocol, J1939 protocol, etc.

5.6 CAN interface for the CANopen protocol, J1939 protocol, etc.

The CAN-The interface is not electrically isolated.



**CAUTION**  
**NON-GALVANICALLY-ISOLATED INTERFACES**

The XV-102-L-... touchdisplay may be damaged by potential differences.

- ▶ The GND terminals of all bus modules must be connected.
- ▶ Do not connect the connector to the XV-102 or disconnect it without first de-energizing the system.

Tab. 17: PIN assignment for CAN interface as specified in CiA  
 SUB-D plug 9-pole, not galvanically isolated, UNC nuts for interlocking

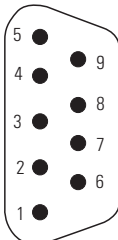
SUB-D plug	PIN	signal	Description
9 pole 	1	n.c.	not used
	2	CAN-L	Bus line (dominant low)
	3	GND	Ground
	4	n.c.	not used
	5	n.c.	not used
	6	GND	Optional Ground
	7	CAN-H	Bus line (dominant high)
	8	n.c.	not used
	9	n.c.	not used

- ➔
- nc: PIN 1, 4, 5, 8 and 9 must not be connected.
  - PIN 3 (CAN-GND) and 6 (GND) are internally inter-connected.
  - The power supply of the CAN bus drivers is implemented internally.
  - A power supply for third party devices is not provided on the CAN connector.

**Wiring topic**

- Screened twisted-pair cables must be used.

Tab. 18: Specifications for CAN wiring

Rated cable impedance		120 Ohm
Permissible impedance		108 ... 132 Ohm
Capacitance per unit length		< 60 pF/m
Core cross-section		100 m 0.25 mm <sup>2</sup>
	With a max. cable length of	250 m 0.34 mm <sup>2</sup>
		500 m 0.75 mm <sup>2</sup>

## 5. External connections

### 5.6 CAN interface for the CANopen protocol, J1939 protocol, etc.

The maximal baud rate depends on the cable length.			
Possible baud rates	With a max. cable length of	25 m	1000 kBit/s
		50 m	800 kBit/s
100 m		500 kBit/s	
250 m		250 kBit/s	
500 m		125 kBit/s	
500 m		100 kBit/s (can be set through software)	
1000 m		50 kBit/s	
2500 m		20 kBit/s	
5000 m		10 kBit/s	



When preparing connections, ensure that the cable shield has a low impedance connection with the connector housing.

#### CAN-Bus-topology

- A bus segment can interconnect up to 32 slaves.
- Several bus segments can be connected using repeaters (bi-directional amplifiers).



The use of repeaters enables the maximum cable length to be increased.

Repeaters can also be used for galvanic isolation. For more details, please consult the documentation for repeaters provided by manufacturer.

Make sure to follow the recommendations provided by CiA (CAN in Automation) at [can-cia.org](http://can-cia.org).

A bus segment must be provided with cable termination (120 Ohm) at both ends.

These terminals must be connected in the plug directly between pin 2 and 7.



The bus segment must be terminated at both ends.

There must not be more than two terminations per bus segment.

Running the bus segment without the right termination may result in transmission errors.

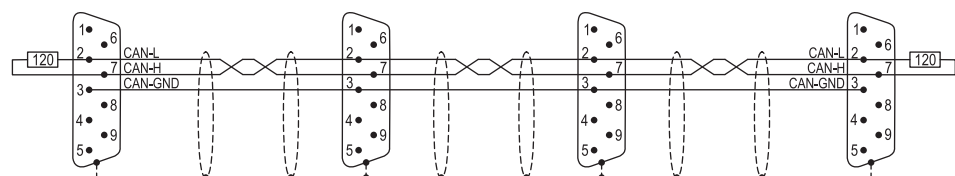

Fig. 21: CAN bus segment with four nodes

## 5.7 Screening the interface cables used

In order to ensure that signals are transmitted without noise so as to comply with EMC B requirements, the communication cables used must be screened.

Use screened cables or screen the cables yourself with a ferrite ring such as:

- Würth STAR-RING snap-together ferrite, split ferrite core, 30 x 20 x 20 mm, for cables with a diameter of 8 mm
- Würth STAR-GAP snap-together ferrite, split ferrite core, 31.5 x 35 x 28.3 mm, for cables with a diameter of 13 mm

Make sure to properly place the ferrite ring on the communication cable at a location close to the connection side (max. distance of 20 cm from the external device plug) on the touch display.

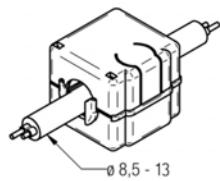

Fig. 22: Screening with snap-together ferrite ring

## 6. Faults

## 6. Faults

This section provides troubleshooting information for your XV-102-L-... touchdisplay in case it does not behave as expected.

<b>Fault</b>	<b>Cause</b>	<b>Remedy</b>
XV-102 will not boot up	No 24 VDC supply voltage	Check the input wiring. Switch on XV-102.
The Resistive touch is not responding or is responding incorrectly when used.	The touch is not calibrated correctly.	Switch on XV-102. Calibrate the touch functionality
	The touch is disabled.	Switch on XV-102. Enable the touch functionality

## 7. Maintenance

### 7.1 Cleaning and maintenance

The XV-102-L-... touchdisplay are maintenance-free.  
However, the following work may need to be carried out:

- Cleaning the Resistive touch when soiled.
- Recalibrating the Resistive touch if it stops responding correctly to touch.

#### 7.1.1 Resistive touch

When soiled:



**CAUTION**  
**POINTY, SHARP OBJECTS AND CORROSIVE LIQUIDS**

When cleaning the XV-102-L-... touchdisplay:

- Do not use any pointy or sharp objects (e.g., knives).
- Do not use aggressive or abrasive cleaning products or solvents.

Make sure that no liquids get into the XV-102-L-... touchdisplay unit (short-circuit hazard) and that the XV-102-L-... touchdisplay unit is not damaged in any way.

- ▶ Clean the Resistive touch with a clean, soft, damp cloth.

#### Recalibrating the resistive touchscreen

The resistive touchscreen will already be calibrated when you receive it. However, it will have to be recalibrated if it stops responding correctly to touch.

#### 7.1.2 Battery

The internal battery used to back up the real-time clock is maintenance-free and is sized for a backup time of normally 10 years at 25° C (77°F) when de-energized, provided the corresponding ambient conditions are met.

## 7. Maintenance

### 7.2 Repairs

### 7.2 Repairs

For repairs, please contact your vendor or Eaton's Technical Support.



**CAUTION  
DESTRUCTION**

The XV-102-L-... touchdisplay should only be opened by the manufacturer or by an authorized center. Operate the XV-102 until only with the enclosure fully closed and sealed.

Use the original packaging to ship the device.

## 7.3 Storage, transport and disposal

### 7.3.1 Storage and transport



**CAUTION  
UV LIGHT**

Plastics will become brittle when exposed to UV light. This artificial aging will reduce the XV-102-L-... touchdisplay unit's lifespan. Protect the XV-102 unit from direct sunlight and other sources of UV radiation.



**CAUTION  
SHORT-CIRCUIT HAZARD**

If the XV-102-L-... touchdisplay is or has been exposed to environmental fluctuations (ambient temperature, air humidity), condensation may form on or inside XV-102. As long as this condensation is present, there will be a short-circuit hazard.

Do not switch on the XV-102-L-... touchdisplay when it has condensation in or on it.

If the XV-102-L-... touchdisplay has condensation in or on it, or if it has been exposed to environmental fluctuations, let the device settle into the existing ambient temperature before switching it on. Do not expose the XV-102-L-... touchdisplay to direct thermal radiation from heating appliances.

The ambient conditions must be met when transporting and storing the XV-102-L-... touchdisplay.

The ambient air temperature for storage and transportation must not exceed the maximum specified limit:

<b>Ambient climatic conditions</b>	
Air pressure (in operation)	795 - 1080 hPa Max. 2000 m above sea level
Temperature	
Operation	$0\text{ }^{\circ}\text{C (32}^{\circ}\text{F)} \leq T \leq 50\text{ }^{\circ}\text{C (122}^{\circ}\text{F)}$
Storage / Transport	$-20 - +60\text{ }^{\circ}\text{C (-4 - +140 }^{\circ}\text{F)}$
Humidity	Relative humidity 10 - 95 %
Condensation	non-condensing

## 7. Maintenance

### 7.3 Storage, transport and disposal



#### Before commissioning

If storing/transporting the device in cold weather conditions or in such a way that it will be exposed to extreme differences in temperature, make sure that no condensation forms on or inside the device.

If there is condensation in or on the device, do not switch on the XV-102 until it is completely dry.

Use the original packaging to ship the device.

The XV-102-L-... touchdisplay is sturdily built, but the components inside it are sensitive to excessively strong vibrations and/or mechanical shock.

Accordingly, make sure to protect the XV-102-L-... touchdisplay from mechanical loads that exceed the scope of the unit's intended use.

The XV-102 should only be transported in its original packaging after being packed properly.

**7.3.2 Disposal**

	<p><b>EXPLOSION HAZARD</b>  <b>LITHIUM BATTERY</b></p> <p>The lithium battery inside the XV-102-L-... touchdisplay may explode if handled incorrectly.</p> <p>▶ Dispose of the XV-102 unit professionally.</p>
---	--

	<p><b>Important!</b></p> <p>Dispose of recyclables as required by your local recycling regulations.</p>
---	---

XV-102-L-... touchdisplay no longer being used must be professionally disposed of as per local standards or returned to the manufacturer or relevant sales department.

Tab. 19: Materials used XV-102-L-... touchdisplay

Assembly part	Material
Display	Glass with polyester layer
Enclosure material	PC-GF (plastic halogen free, gray)
Battery	Panasonic, Lithium BR1225 3.0V 48mAh Weight (g): 0.8 SVHC substance: 1.2-dimethoxyethane (DME), ethylene glycol dimethyl ether (EGDME) Substance weight (%): 2-4  or  Renata Lithium CR1025 3.0V 30mAh Weight (g): 0.6 SVHC substance: 1.2-dimethoxyethane (DME), Substance weight(%): 1-3.5

Tab. 20: Materials used in the packaging

Packaging	Material
Outer packaging	Cardboard
Internal packaging:	
3.5" devices	Cardboard with PE sheet Plastic bag: polyethylene (PE)
5.7" and 7.0" devices	Cardboard Plastic bag: polyethylene (PE)

## Appendix

---

<a href="#">A.1 Technical data</a> .....	<b>66</b>
A.1.1 Dimension and weight specifications .....	67
A.1.2 General data .....	70
A.1.3 Port and interface specifications .....	72
A.1.4 Information on the power supply .....	73
A.1.5 Approvals and declarations .....	74
<a href="#">A.2 Further usage information</a> .....	<b>76</b>

## A.1 Technical data

### Data sheets

The current specifications for the device can be found in the corresponding data sheet at [Eaton.com/ecat](http://Eaton.com/ecat)

Currently available for front installation with Resistive touch TFT-LCD, 64 k colors:

Display	Type Catalog No.	Slot SD card	interface					PLC Function
			Ethernet 100/10	USB host	RS- 232	RS- 485	CAN	
3.5"	XV-102-L3-35TQR-10 EP-401342	1	1	1	1	-	-	-
3.5"	XV-102-L4-35TQR-10 EP-401343	1	1	1	-	1	-	-
3.5"	XV-102-L5-35TQR-10 EP-401344	1	1	1	1	-	1	-
3.5"	XV-102-L5-35TQRC-10 EP-401345	1	1	1	1	-	1	1
3.5"	XV-102-L6-35TQRC-10 EP-401346	1	1	1	-	1	1	1

Display	Type Catalog No.	Slot SD card	interface					PLC Function
			Ethernet 100/10	USB host	RS- 232	RS- 485	CAN	
5.7"	XV-102-L4-57TVR-10 EP-401347	1	1	1	1	1	-	-
5.7"	XV-102-L6-57TVR-10 EP-401348	1	1	1	1	1	1	-
5.7"	XV-102-L6-57TVRC-10 EP-401349	1	1	1	1	1	1	1

Display	Type Catalog No.	Slot SD card	interface					PLC Function
			Ethernet 100/10	USB host	RS- 232	RS- 485	CAN	
7.0"	XV-102-L4-70TWR-10 EP-401350	1	1	1	1	1	-	-
7.0"	XV-102-L6-70TWRC-10 EP-401351	1	1	1	1	1	1	1

Display	Type Catalog No.	Slot SD card	interface					PLC Function
			Ethernet 100/10	USB host	RS- 232	RS- 485	CAN	
3.5" QVGA	XV-102-L0-35TQRB-1E4 EP-401718	1	1	1	-	-	-	-
5.7" VGA	XV-102-L0-57TVRB-1E4 EP-401719	1	1	1	-	-	-	-

## Appendix A.1 Technical data

### A.1.1 Dimension and weight specifications

#### A.1.1.1 3.5" Display

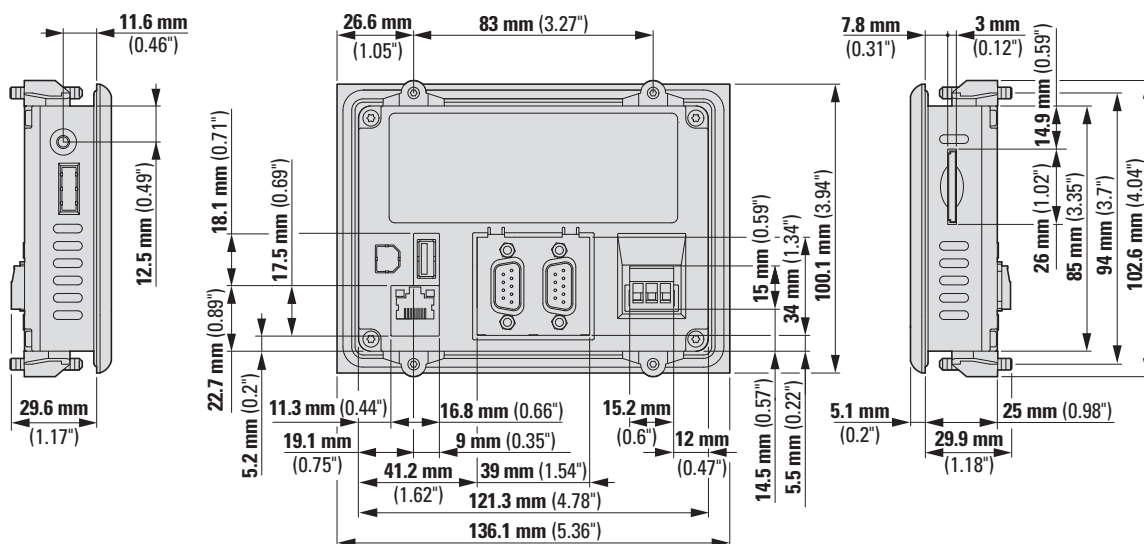

Fig. 23: Dimensions for 3.5" front mounting devices in mm (inches)

Width x Height x Depth 136 mm x 100 mm x 35 mm  $\pm 0.2$  (7.72" x 5.31" x 2.01")  
(without plug)

Weight 0.3 kg (0.66 lbs)

**A.1.1.2 5.7" Display**

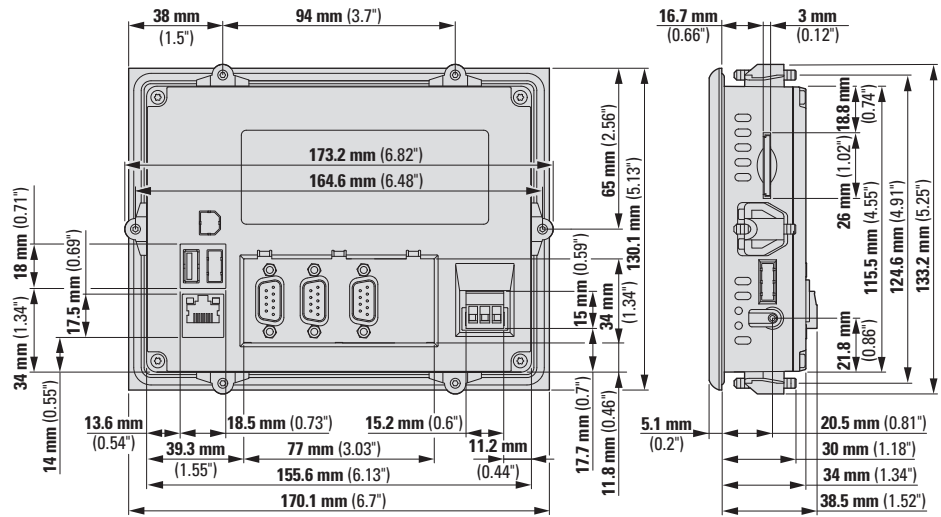

Fig. 24: Dimensions for 5.7" front mounting devices in mm (inches)

Width x Height x Depth 170 mm x 130 mm x 43 mm  $\pm 0.2$  (10.59" x 6.85" x 2.28")  
(without plug)

Weight 0.6 kg (1.32 lbs)

# Appendix

## A.1 Technical data

### A.1.1.3 7.0" Display

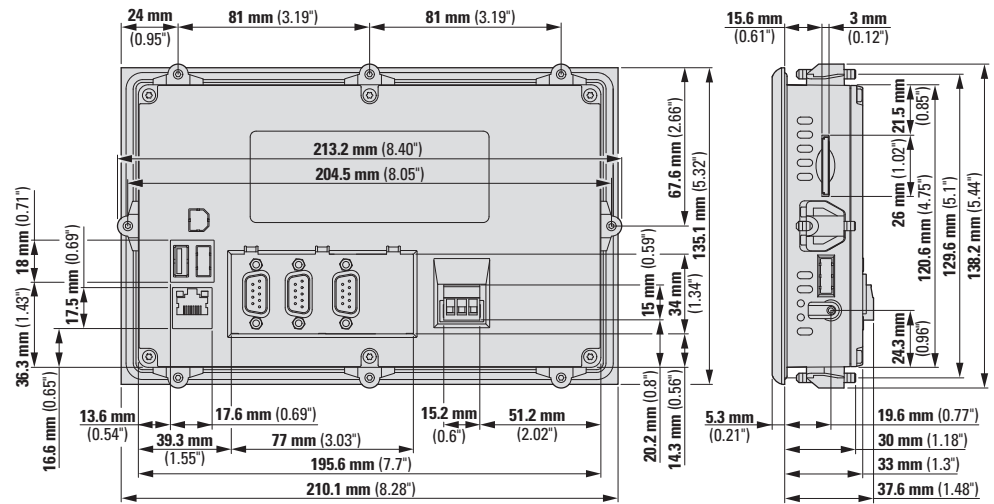

Fig. 25: Dimensions for 7.0" front mounting devices in mm (inches)

Width x Height x Depth 210 mm x 135 mm x 43 mm  $\pm 0.2$  (15.9" x 10.04" x 2.661"  $\pm 0.008$ )  
(without plug)

Weight 0.6 kg (1.32 lbs)

**A.1.2 General data**

<b>Display</b>	
Catalog number	TFT-LCD
<b>Resolution (W × H)</b>	
3.5" devices	QVGA (320 × 240 pixels)
5.7" devices	VGA (640 × 480 pixels)
7.0" devices	WVGA (800 × 480 pixels)
<b>Visible screen area</b>	
3.5" devices	70 mm × 53 mm (3.5" screen diagonal)
5.7" devices	115 mm × 86 mm (5.7" screen diagonal)
7.0" devices	152 mm × 91 mm (7.0" screen diagonal)
Color resolution	64k colors
Contrast ratio (Normally)	Normally 300:1
Brightness	Normally 250 cd/m <sup>2</sup>
<b>Backlight</b>	
Technology	LED
Dimmable with software	
3.5" devices	100 % ... 2 % brightness
5.7" devices	100 % ... 20 % brightness
7.0" devices	100 % ... 20 % brightness
Life point	Normally 40 000 h
Resistive touch protective screen	Touch sensor (glass with foil)
<b>Touch sensor</b>	
Catalog number	Resistive touch
Technology	4-wire
<b>System</b>	
Processor	RISC, 32 Bit, 800 MHz
<b>Internal memory</b>	
DRAM	512 MByte
Internal memory	4 GByte
NVRAM	125 kByte
<b>External memory</b>	
SD Memory Card Slot	One SDSC or SDHC conforming to the SDA 2.0 specification – use genuine accessories only!
<b>Real-time clock (battery back-up)</b>	
Battery type	CR1025, maintenance-free (soldered)
Backup time at zero voltage	Normally 10 years

## Appendix

### A.1 Technical data

<b>Battery</b>	<p>Panasonic, Lithium BR1225 3.0V 48mAh Weight (g): 0.8 SVHC substance: 1.2-dimethoxyethane (DME), ethylene glycol dimethyl ether (EGDME) Substance weight (%): 2-4</p> <p>or</p> <p>Renata Lithium CR1025 3.0V 30mAh Weight (g): 0.6 SVHC substance: 1.2-dimethoxyethane (DME), Substance weight(%): 1-3.5</p>
<b>Protection Style</b>	
Front	<p>IP65, enclosure type 4X (indoor use only) Required number of retaining brackets and threaded pins for mounting:</p> <ul style="list-style-type: none"> <li>• 3.5" devices: 4 pieces each</li> <li>• 5.7" devices: 6 pieces each</li> <li>• 7.0" devices: 8 pieces each</li> </ul>
Back	IP20, enclosure type 1

**A.1.3 Port and interface specifications**

Ethernet	10/100 Mbps
USB host	USB 2.0 (1.5 / 12 / 480 MBit/s), not galvanically isolated
Interfaces, depending on the device version:	
RS-232 (System Port)	SUB-D plug, 9-pole, UNC, not galvanically isolated
RS-485	SUB-D plug, 9-pole, UNC, not galvanically isolated
CAN	SUB-D plug, 9-pole, UNC, not galvanically isolated

## Appendix

### A.1 Technical data

#### A.1.4 Information on the power supply

Power Supply	
rated operating voltage	+ 24 VDC SELV (safety extra low voltage)/PELV (protective extra low voltage)
permissible voltage range	Effective: 19.2-30.0 V DC (rated operating voltage -20%/+25%)
	Absolute with ripple: 18.0-31.2 V DC
	Battery powered: 18.0-31.2 V DC (rated operating voltage -25%/+30%); 35 V DC for a duration of < 100 ms
Voltage dips	Ability to accommodate brief voltage dips ≤ 10 ms, in accordance with IEC61131-2
Power consumption	
XV-102-L.-35-..	max. 5 W Current consumption at 24 V DC: 5 W for basic device + 2.5 W for USB module
XV-102-L.-57-..., XV-102-L.-70-..	max. 7 W Current consumption at 24 V DC: 7 W for basic device + 2.5 W for USB module
fuse	Yes (fuse not accessible)
Potential isolation	no
Protection against polarity reversal	Yes

Electrical current	3.5" display	5.7" display	7.0" display
$I_e$	≤ 0.3 A	≤ 0.4 A	≤ 0.4 A
$I_{TH}$		1.0 A <sup>2</sup> s	
Starting current inrush		1.5 A <sup>2</sup> s	

### A.1.5 Approvals and declarations

The following specifications apply to all XV-102-L-... touchdisplay units.

<b>Approvals and declarations</b>	
cUL	UL508, UL File No. E205091
CE	XV-102 units comply with all applicable European Union (EU) Directives and feature the CE marking.
NEMA	XV-102 devices comply with the applicable guidelines in North America
Explosion protection	<p>II 3D Ex tc IIIC T70°C IP6x: zone 22, category 3D</p> <ul style="list-style-type: none"> <li>• IP5x for group IIIB devices (nonconductive dust)</li> <li>• IP6x for group IIIC devices (conductive dust)</li> </ul> <p>For front mounting: fixing material that must be installed as specified without fail                      -XV-102-L.-35-...: on each 4 x Holding bracket with set screw                      -XV-102-L.-57-...: on each 6 x Holding bracket with set screw                      -XV-102-L.-70-...: on each 8 x Holding bracket with set screw</p>
Marine approval (shipping classification)	Type approval for the XV-102-L-... touchdisplay – provided that a radio interference suppression filter for the device is installed in the wiring DNVGL-CG-0039, from 11/2015 DNV GL Type Approval Certificate No: TAA00000NC

<b>Applied standards and directives</b>	
EMC (relevant for CE)	2004/108/EEC 2014/30/EU
	IEC/EN 61000-6-2 Interference immunity for industrial environments
	IEC/EN 61000-6-4 Emitted interference for industrial environments
	IEC/EN 61131-2 Interference immunity and emission for programmable logic controllers
	IEC/EN 61000-6-3 Emitted interference standard for residential, commercial and light-industrial environments (only applies without connection to the USB interfaces)
Explosion protection (relevant for CE)	ATEX directive 94/9/EG 2014/34/EG
	IEC/EN 60079-0 Explosive atmospheres: Equipment - General requirements
	IEC/EN 60079-31 Explosive atmospheres: Equipment dust ignition protection by enclosure "t"
Security	
	IEC/EN 60950 Safety of Information Technology Equipment
	UL508 Industrial Control Equipment → Section "Technical conditions for acceptance by Underwriters Laboratories Inc. (UL)", page 34
	DIN EN 60529 Degrees of protection provided by enclosures
	NEMA 250-2003 Enclosures for electrical equipment (1000 Volts maximum)
Product standards	
	DIN EN 60898-1:2006-03 Electrical accessories - Circuit-breakers for overcurrent protection for household and similar installations
	EN 50178_x Electronic equipment for use in power installations
	IEC/EN 61131-2 Programmable controllers: Equipment requirements and

## Appendix A.1 Technical data

Applied standards and directives		
		tests
Mechanical shock resistance	IEC/EN 60068-2-27	15g /11ms
Vibration	IEC/EN 60068-2-6	Displacement amplitude: 5–9 Hz: 3.5 mm; 9–60 Hz: 0.15 mm Acceleration amplitude: 60–150 Hz: 2 g
Free fall, packaged	IEC/EN 60068-2-31	
RoHS	Directive 2011/65/EG	conform
Climatic proofing	Cold to IEC 60068-2-1	
	Damp heat as per EN 60068-2-3	
	Dry heat to IEC60068-2-2	

Tab. 21: Overcurrent and short-circuit protective device standards

Standard	Overcurrent and short-circuit protective device
DIN VDE 0641, part 11 and EC/EN 60898	Miniature circuit-breaker 24 V DC, rated operational current 3 A, trip type Z fuse 3 A, Utilization category gL/gG
UL508	Miniature circuit-breaker 24 V DC, rated operational current 2 A, trip type Z fuse 2 A

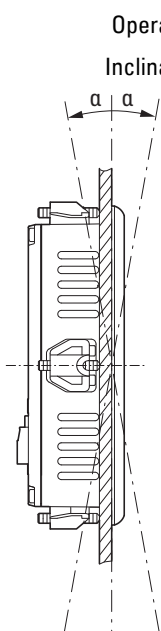
Ambient climatic conditions	
Air pressure (in operation)	795 - 1080 hPa Max. 2000 m above sea level
Temperature	Operation Inclination $0^{\circ}\text{C} (32^{\circ}\text{F}) \leq T \leq 50^{\circ}\text{C} (122^{\circ}\text{F})$
	 <p>Inclination from vertical: <math>\alpha \leq 45^{\circ}</math> at operating temperature <math>\leq 50^{\circ}\text{C} (122^{\circ}\text{F})</math> possible (if using natural convection)</p>
Storage / Transport	$-20 - +60^{\circ}\text{C} (-4 - +140^{\circ}\text{F})$
Humidity	Relative humidity 10 - 95 %
Condensation	non-condensing

## A.2 Further usage information

### Hardware

For more information on additional devices and modules or the use of XV-102, please refer to the following documentation:

 [Instruction leaflet XV-102](#) IL048021ZU

### Software

 GALILEO 11 - user help is available in the software MN048032EN

 [System description embedded linux](#) MN050017EN

### Communication

HMI-PLCs are able to communicate with a variety of PLCs. In order to integrate your XV-102 into your system, additional settings will need to be configured as appropriate for the PLC being used.

The following documents, together with other documentation, explain what needs to be taken into account and configured:

 [Networks in Brief](#) MN05010009Z

### Tutorials

For helpful videos that explain how to use specific functions, please visit the corresponding product pages on the Internet.

 [GALILEO Videos](#)

### Download Center,Eaton Online Catalog

Enter "XV100" into the search box and the catalog will take you directly to the corresponding product group in the Automation, Control and visualization section.

 [Eaton.com/documentation](http://Eaton.com/documentation)

 [Eaton.com/ecat](http://Eaton.com/ecat)

### Product information

For up-to-date information, please consult the product page on the Internet.

 [Eaton.com/xv100](http://Eaton.com/xv100)

## Alphabetical index

### A

Accessory devices .....	19
Aeration and de-aeration .....	33
After Sales Service .....	2
Ambient climatic conditions .....	32, 62, 75
Approvals .....	74

### B

Basic equipment .....	14
Battery .....	60
Brand names	
Product names .....	2
Bundle .....	18

### C

CAN .....	17, 49, 56
CANopen .....	56
Cleaning .....	60
COM .....	17
COM1 .....	17, 49
COM2 .....	17, 49
Commissioning .....	45
Company information .....	2
Connections	
External .....	48
Copy-protected .....	2
Copyright .....	2
CTRL button .....	16
Current .....	43, 73

### D

Damage .....	37
--------------	----

Declarations .....	74
Description .....	12
Dimension	
3.5" .....	67
10.1" Display front mounting .....	68
15.6" Display front mounting .....	69
Dimensions .....	67
Directives .....	74
Display .....	16
Disposal	
Recycling .....	64
Download Center .....	76

### E

Earthing .....	43
ecat .....	76
Equipment supplied .....	37
Ethernet .....	52
Ethernet 1 .....	17, 49

### F

Faults .....	59
Features .....	12
Front mounting .....	38
Function .....	12
Further reading .....	76

### G

General data .....	70
--------------------	----

### H

Hazards	
Device-specific .....	26
Hole diameter built-in .....	39

<b>I</b>		
Initial commissioning .....	45	
Installation .....	31	
Installation position		
Clearances .....	39	
Selection .....	31	
Intended use .....	13	
Interfaces .....	17, 72	
Equipment .....	17	
Ethernet .....	52	
Optional .....	49	
RS-232 .....	53	
RS-485 .....	54	
SD card .....	50	
serial .....	53	
Type .....	17, 49	
USB host .....	51	
interfaces		
CAN .....	56	
USB peripheral devices .....	51	
Interfaces options .....	49	
<b>J</b>		
J1939 .....	56	
<b>L</b>		
Label .....	20	
Lifespan		
Backlight .....	46	
Location of use .....	31	
<b>M</b>		
Maintenance .....	60	
Manuals .....	76	
Marine approval .....	35	
Marine approvals .....	22	
Materials used .....	64	
Missing parts .....	37	
Mounting .....	38	
Mounting distance .....	33	
Mounting position		
SD card .....	31	
<b>N</b>		
Nameplate .....	17, 20, 49	
<b>O</b>		
Online Catalog .....	76	
Operating elements .....	16	
Operation		
Proper .....	25	
Original Operating Instructions .....	2	
<b>P</b>		
Package contents .....	37	
Part number .....	18	
Ports .....	48	
Power consumption .....	43, 73	
Power supply .....	43-44, 73	
<b>R</b>		
Radio interference filter .....	36	
Repairs .....	61	
Resistive touch .....	16, 60	
RS-232 .....	17, 49, 53	
RS-485 .....	17, 49, 54	
<b>S</b>		
Safety .....	23	
SD card .....	50	
SD card slot .....	16	

Service .....	20
Shipping classification .....	22, 35
Standards .....	74
Std. pack .....	37
Storage .....	62
Support .....	20

## **T**

Technical data .....	66
Touch sensor .....	16
Transit damage .....	37
Transport .....	62
Troubleshooting .....	59

## **U**

UL listing .....	21
USB host .....	17, 49, 51
USB peripheral devices .....	51

## **V**

Versions .....	14, 18
Voltage range .....	43, 73

## **W**

Weight .....	67
--------------	----

Eaton is an intelligent power management company dedicated to protecting the environment and improving the quality of life for people everywhere. We make products for the data center, utility, industrial, commercial and institutional, machine building, residential, aerospace and mobility markets. We are guided by our commitment to do business right, to operate sustainably and to help our customers manage power – today and well into the future. By capitalizing on the global growth trends of electrification and digitalization, we're helping to solve the world's most urgent power management challenges and building a more sustainable society for people today and generations to come.

Founded in 1911, Eaton has continuously evolved to meet the changing and expanding needs of our stakeholders. With revenues of \$27.4 billion in 2025, the company serves customers in 180 countries.

For more information, visit [eaton.com](https://www.eaton.com). Follow us on [LinkedIn](#).



*Powering Business Worldwide*

**Eaton Industries GmbH**

Hein-Moeller-Str. 7-11

D-53115 Bonn

© 2023 Eaton Corporation

All Rights Reserved

04/2026 MN048030EN