

Installation and operating manual

SHK 20-200

Indoor unit
Cooperating with air
heat pumps

EKSPERTER I VARME OG VARMT VAND



METRO THERM

11-12-2023
31573

List of content

1 Important information _____	4	7 Commissioning and adjusting	41
SHK - Safety information _____	4	Preparations _____	41
METROAIR L - SAFETY INFORMATION ___	6	Filling and venting _____	41
2 Delivery and handling _____	14	Circulation pump _____	42
Available models _____	14	Commissioning _____	42
Compatibility _____	14	Start Guide _____	42
Transport _____	14	Pressure relief valve _____	43
Assembly _____	14	8 Control - Introduction _____	44
Installation location _____	15	Display unit _____	44
Removing the cover _____	15	Menu system _____	45
Supplied components _____	15	9 Control _____	48
3 Design of the indoor unit _____	16	Menu 1 - INDOOR CLIMATE _____	48
SHK 20-200 _____	16	Menu 2 - HOT WATER _____	49
4 Pipe connections _____	18	Menu 3 - INFO _____	49
General information _____	18	Menu 4 - MY SYSTEM _____	50
System diagram _____	19	Menu 5 - SERVICE _____	51
Pipe connections _____	23	Start guide _____	52
Docking the indoor unit _____	24	Settings for the user _____	54
Connection options _____	28	Submenu SERVICE _____	63
DHW circulation _____	30	Cooling settings _____	69
5 METROAIR L outdoor unit _____	31	10 Service _____	70
Transport and storage _____	31	Service actions _____	70
Assembly _____	31	11 Disturbances in comfort _____	74
Lift from the street to the set up location _	31	Troubleshooting _____	74
Lift from the pallet to final positioning _	32	Additional heating only _____	75
Scrapping _____	32	12 Accessories _____	76
Condensation water drain _____	32	Connecting the KVR accessory _____	77
Recommended for leading off condensation water _____	32	Connecting an additional heat source _	78
Maintenance of METROAIR L _____	33	Connecting the expansion card _____	79
Dimensions _____	34	Connection of an additional GP10 pump	79
Installation location _____	35	13 Technical data _____	80
Sound power levels _____	35	Technical data _____	81
6 Electrical connections _____	36	Energy efficiency label _____	84
General information _____	36	Energy efficiency specifications of the pack- age _____	84
Connections _____	37	Energy label _____	85
Additional connections _____	39	Electrical wiring diagrams _____	87
Settings _____	40		

1 Important information

SHK - Safety information

This manual contains installation and service procedures for implementation by specialists.

This appliance can be used by children aged 8 years and above and persons with reduced physical, sensory or mental capacity or lack of experience and knowledge, if they will be supervised or have received instruction concerning safe use of the appliance, and if they understand the danger involved in its use. Children must not play with the appliance. Cleaning and basic maintenance of the appliance must not be carried out by children unsupervised.

The rights to make structural changes are reserved.

©METROTHERM 2023

Symbols

NOTE
This symbol indicates danger to the appliance or person.

TIP
This symbol indicates tips that will make it easier to operate the product.

Caution
This symbol indicates important information to note while operating or maintaining the appliance.

Marking

SHK 20-200 is CE marked and has an IP21 protection rating.

The CE mark confirms that METROTHERM has ensured that the product conforms to all applicable regulations specified by the relevant EU directives. The CE mark is mandatory for most products sold in the EU, regardless of where they are made.

IP21 means that objects with a diameter greater than or equal to 12.5 mm cannot penetrate and cause damage and that the product is protected against vertically falling drops of water.

Serial number

The serial number is located at the bottom of the rating plate, on the top cover SHK 20-200 and consists of 14 digits.

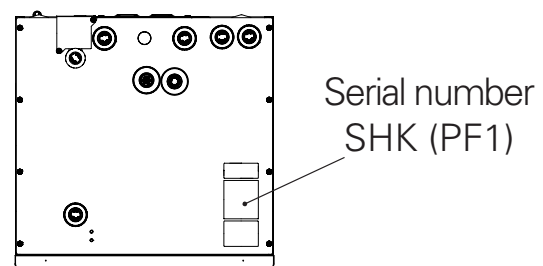

Waste disposal

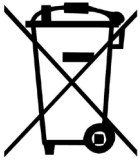

Leave the disposal of the packaging to the installer who installed the product or to a special waste disposal facility.

Do not dispose of used products with normal household waste. It must be

transported to a special waste disposal facility or to a vendor who provides this type of service.

Improper disposal of the product by the user may result in administrative penalties in accordance with the applicable legislation.

Inspection of the installation

The climate system must be inspected before commissioning. The inspection must be carried out by a suitably qualified person. In addition, fill in the page for the installation data in the User Manual.

Checklist

	Description	Notes	Signature	Date
	Heating medium			
	Flushing the system			
	System vented			
	Expansion vessel			
	Particulate filter			
	Safety valve			
	Shut-off valves			
	Pressure in the climate system			
	Connected according to outline diagram			
	Leak test			
	Hot water			
	Shut-off valves			
	Mixing valve			
	Safety valve			
	Electric power supply			
	Connecting communication			
	Perimeter protection			
	Protection, indoor unit			
	Building protection			
	Outdoor temperature sensor			
	Room sensor			
	Current sensor			
	Safety circuit breaker			
	Residual-current device			
	Setting the thermostat to emergency mode			
	Miscellaneous			
	Docked to			

METROAIR L - SAFETY INFORMATION

Electrical installation and wiring must be carried out in accordance with national provisions.

METROAIR L must be installed via an isolator switch. The cable area has to be dimensioned based on the fuse rating used. If the supply cable is damaged, only METROTHERM, its service representative or similar authorised person may replace it to prevent any danger and damage.

Fixed pipe connection

METROAIR L is intended for a fixed pipe connection to heating and/or the hot water system.

Handling

The heat pump contains A2L refrigerant. Special care should be exercised during handling, installation, service, cleaning and scrapping to prevent damage to the refrigerant system and thus reduce the risk of leakage.

! NOTE
Work on refrigerant systems must be carried out by personnel who have knowledge and experience of working with flammable refrigerants.

Environmental information

F-gas regulation (EU) no. 517/2014

This unit contains a fluorinated greenhouse gas that is covered by the Kyoto agreement.

The equipment contains R32, a fluorinated greenhouse gas with a GWP value (Global Warming Potential) of GWP 675. Do not release R32 into the atmosphere.

Safety precautions

! NOTE
Do not use agents to speed up the defrosting process or for cleaning, other than those recommended by the manufacturer.

The apparatus must be stored in a room with no continuous ignition sources (e.g. naked flame, an active gas installation or an active electric heater).

Must not be punctured or burned. Be aware that the refrigerant may be odourless.

General

Pipe installation should be kept to a minimum.

Mechanical connections of the cooling circuit made on site must be accessible during servicing.

The cooling circuit's pipes must be protected against physical damage.

Area checks

Before work is started on systems that contains combustible refrigerants, safety checks must be performed to ensure that the ignition risk is kept to a minimum.

Working method

The work must be carried out in a controlled way to minimise the risk of contact with combustible gas or liquid during the work.

General for the working range

All maintenance staff and those who work in close proximity to the product must be instructed which type of work is to be carried out. Avoid carrying out work in enclosed spaces. The area surrounding the worksite must be cordoned off. Ensure that the area is made safe by removing combustible material.

Check for the presence of refrigerant

Check whether there is refrigerant in the area using a suitable refrigerant detector prior to and during work, to notify the service technician whether there is a possible flammable atmosphere or not. Ensure that the refrigerant detector is suitable for combustible refrigerant, i.e. does not generate sparks or cause ignition in any other way.

Presence of fire extinguishers

If hot work is carried out on the heat pump, a powder or carbon dioxide fire extinguisher must be to hand.

Absence of ignition sources

Pipes connected to the unit must not contain potential sources of ignition.

Those who carry out work with refrigerant system connections, including exposing pipes that contain or have contained combustible refrigerant, may not use potential ignition sources in such a way that that can lead to risks of fire or explosions.

All potential ignition sources, including cigarette smoking, should be kept at a safe distance from the service work area where combustible refrigerant can leak out. Before carrying out work, the area surrounding the equipment must be checked to ensure that there are no ignition risks. „No smoking“ signs must be displayed.

Ventilated area

Ensure that the work is carried out outdoors or that the work area is ventilated before the system is opened and before any hot work is carried out. The area must be ventilated whilst the work is being carried out. There must be ventilation around any refrigerant that comes out, which should be routed outdoors.

Checking cooling equipment

If electrical components are replaced, the replacement parts must be fit for purpose and have the correct technical specifications. Always follow the manufacturer's guidelines regarding maintenance and servicing. Contact the manufacturer's technical department in the event of any doubts. The following checks must be carried out for installations that use combustible refrigerants.

- The actual filling quantity is appropriate for the magnitude of the space where the parts containing refrigerant are installed.
- Ventilation equipment and outlet

work correctly and without obstructions.

- If an indirect refrigerant circuit is used, check whether the secondary circuit contains refrigerant.
- All markings of equipment are visible and clear. Markings, signs and similar that are not clear must be replaced.
- Refrigerant pipes and components are positioned in such a way that it is not likely that they be subjected to substances that can corrode components containing refrigerant, if these components are not made of material that is resistant against corrosion, or not appropriately protected against such corrosion.

Checking electrical equipment

Repair and maintenance of electrical components must include initial safety checks and procedures for component inspection. In the event of a fault, which can cause a safety risk, do not supply any power to the circuit until the fault has been rectified. If the fault cannot be rectified immediately, and operation must continue, an adequate temporary solution must be implemented. This must be reported to the equipment owner, so that all parties have been informed.

The following checks must be carried out at the initial safety checks.

- That the capacitors are discharged. Discharging must be done safely, to prevent the risk of sparking.
- That no powered electrical components or live cables are exposed when filling or collecting refrigerant or when the system is flushed.
- That the system is continually earthed.

Repairing sealed components

When repairing sealed components, all electrical supply must be disconnected from the equipment that is being repaired before any sealed covers or similar are removed. If it is absolutely necessary to have an electricity supply to the equipment during the service, continuously activated leak tracing must be performed at the most critical points in order to warn of any dangerous situations.

Pay particular attention to the following so that the sheath is not changed in a way that affects the protection level when working with electrical components. This means damage to cables, unnecessary amounts of connections, terminals that do not follow the original specifications, damaged gaskets, incorrect grommets etc.

Ensure that the apparatus is secured properly.

Check that seals or sealing materials have not deteriorated to a degree that they can no longer prevent combustible gases from entering. Replacement parts must meet the manufacturer's specifications.



NOTE

- Use of silicone seals can hamper the efficiency of certain types of leaktracing equipment. Components with built in safety do not need to be isolated before starting work.

Wiring

Check that cabling will not be subject to wear, corrosion, excessive pressure, vibration, sharp edges or any other adverse environmental effects. The check shall also take into account the effects of aging or continual vibration from sources such as compressors or fans.

Leak testing

The following leak detection methods are deemed acceptable for systems containing flammable refrigerants.

Electronic leak tracers must be used to detect combustible refrigerant; but the leak tracer may not be sufficiently sensitive or may need to be recalibrated (the leak tracing

equipment must be calibrated in an area completely free from refrigerant). The leak tracer must not be a potential source of ignition and must be suitable for the relevant refrigerant. The leak tracing equipment must be set and calibrated for the relevant refrigerant, to ensure that the gas concentration is a maximum of 25% of the lowest combustible concentration (Lower Flammability Limit, LFL) of the relevant refrigerant.

Leak detection fluids are suitable for use with most refrigerants but the use of detergents containing chlorine shall be avoided as the chlorine may react with the refrigerant and corrode the copper pipework.

If a leak is suspected, all naked flames shall be removed/extinguished. If a leak that requires brazing is detected, all refrigerant must be removed from the system and stored in a separate container. Alternatively, the refrigerant can be stored separated from the brazing area in a part of the system at a safe distance from the leak, if this part of the system can be disconnected safely with shut-off valves. The system must be emptied in accordance with the section "Removal and draining".

Removal and draining

When a cooling circuit is opened for repairs – or for another reason – work must be carried out in a conventional manner. Due to the risk of fire it is important that best practice is applied. Follow the procedure below.

1. Remove the refrigerant
2. Open the circuit by cutting or brazing.

Collect the refrigerant in the intended cylinders.

Ensure that the vacuum pump's outlet is not near to any potential ignition sources and that there is satisfactory ventilation by the outlet.

Filling

In addition to the conventional filling procedures, the following actions must be taken.

- Ensure that different refrigerants are not mixed when filling equipment is used. Hoses and lines must be as short as possible to minimise the enclosed refrigerant volume.
- Containers must be stored in a suitable position in accordance with the instructions.
- Ensure that the cooling system is grounded before the system is filled with refrigerant.

- Mark the system once filling is complete (if not already marked). If the amount differs from the pre-installed amount, the marking must include the pre-installed amount, the added extra amount and the total amount.
 - Take extra care not to overfill the cooling system.
2. Isolate the system electrically.
 3. Before starting the procedure, ensure that:
 - necessary equipment for mechanical handling of the refrigerant container is available
 - all necessary personal safety equipment is available and used correctly
 - the collection process is continuously supervised by an authorised person
 - the collection equipment and containers meet appropriate standards.

Before refilling the system, pressure test it with oxygen-free nitrogen. Leak test the system after filling but before using the system. Perform an additional leak test before leaving the installation.

Decommissioning

Before the device is taken out of operation, the technician must without exception be very familiar with the equipment and all its component parts. Good practice prescribes that all refrigerant is collected safely. Before the collected refrigerant can be reused, oil and refrigerant samples must be taken, if analysis is required. There must be a power supply when this task is started.

1. Familiarise yourself with the equipment and its use.
4. Pump the refrigerant system to vacuum, if possible.
5. If it is not possible to pump to vacuum, manufacture a branch, so that the refrigerant can be retrieved from different parts of the system.
6. Check that the refrigerant container is on the scales before starting to collect.
7. Start the collection device and collect according to the manufacturer's instructions.
8. Do not overfill the containers (max. 80 % (volume) liquid content).
9. Do not exceed the containers' maximum permitted working pressure – not even temporarily.
10. When the containers have been filled correctly and the process is complete, close all shut-off valves in the equipment and remove and containers and equipment from the installation immediately.

11. The collected refrigerant must not be filled in any other system before being cleaned and checked.

Marking

The equipment must be marked stating that it has been taken out of operation and drained of refrigerant. The marking must be dated and signed. Check that the equipment is marked indicating that it contains combustible refrigerant.

Collection

Best practice prescribes that all refrigerant is collected safely when the refrigerant is drained from a system, either for servicing or for decommissioning.

The refrigerant must only be collected in suitable refrigerant containers. Ensure that the required number of containers, which can hold the entire volume of the system, are available. All containers that are to be used must be intended for the collection of the refrigerant and marked for this refrigerant (specifically designed for the collection of refrigerant). The containers have to be equipped with correctly functioning pressure relief valves and shut-off valves. Empty collection containers must be drained and, if possible, chilled before collection.

The collection equipment must

function correctly and instructions for the equipment must be to hand. The equipment must be suitable for the collection of combustible refrigerant.

Fully functioning and calibrated scales must also be to hand.

Hoses must be in good condition and be equipped with leak-proof quick couplings. Before using the collecting machine, check that it is working correctly and has been properly maintained. Associated electrical components must be sealed, to prevent ignition if any refrigerant should leak out. Contact the manufacturer if you are in any doubt.

Return the collected refrigerant to the refrigerant supplier in the correct collection container and with the relevant Waste Transfer Note. Do not mix refrigerants in collection devices or containers.

If compressors/compressor oil are/is to be removed ensure that the affected device is drained to an acceptable level to ensure that no combustible refrigerant remains in the lubricant. Compressors must be drained before being returned to the supplier. Only electrical heating of the compressor housing may be used to quicken draining. Drain oil from the system in a safe manner.

Miscellaneous

Maximum amount of refrigerant:
See Technical Specifications in the
Installer Manual.

- Everyone who works with or opens a refrigerant circuit must have a current, valid certificate from an accredited industry issuing body, which states that, according to the industry's recognised assessment standard, they have the authority to safely handle refrigerants.
- Servicing must only be performed according to the equipment manufacturer's recommendations.

Maintenance and repairs that require the assistance of another trained person must be carried out under the supervision of person with the authority to handle combustible refrigerants.

Maintenance and repair that requires the skill of another person must be carried out under the supervision of someone with the above expertise.

2 Delivery and handling

Available models

- SHK 20-200 units include the following separate models:
- SHK 20-200/6 – unit dedicated for use with L6.1 Split, enamelled tank equipped with a titanium anode.
 - SHK 20-200/12 – unit dedicated for use with L10.1 Split, enamelled tank equipped with a titanium anode.

Compatibility

The SHK 20-200 unit can be used with Split type outdoor units. The compatible METROTHERM SPLIT heat pumps are:

Indoor unit	Compatibility
SHK 20-200/6	L6.1
SHK 20-200/12	L10.1

More information on METROTHERM SPLIT heat pumps available at www.metrotherm.dk and in dedicated installation and user manuals.

See section „Accessories” for the list of accessories to be used with SHK 20-200.

Transport

The SHK 20-200 indoor unit should be transported and stored vertically. Storage location must be dry. SHK 20-200 can be transported into the building vertically or carefully placed on the rear wall with the display facing up.

Assembly

REQUIREMENTS FOR INSTALLATION SPACE „(R32)”

For systems with a total refrigerant amount less than 1.84 kg R32, there is no space requirement.

SHK 20-200/6 +METROAIR L6.1 Split

SHK 20-200/6 with the L6.1 unit is filled with 1.3 kg of refrigerant from the factory and therefore has no specific requirements regarding installation space. If the pipe length exceeds 15 m (max. 30 m), refrigerant must be charged at 0.02 kg/m (max. 0.3 kg). The total refrigerant amount is always below the limit value of 1.84 kg.

SHK 20-200/12 + METROAIR L10.1 Split

SHK 20-200/12 with the L10.1 unit is filled with 1.84 kg of refrigerant from the factory. When the pipe length is longer than 15 m, the refrigerant must be filled to max. 0.02 kg/m. Because the total refrigerant amount then exceeds 1.84 kg, the accessory AGS 10 (automatic gas separator) must be installed and consideration must be given to the size of the installation space with regard to the total amount of refrigerant. A total refrigerant amount exceeding 2.54 kg R32 is not permitted in the system. See table „Minimum floor area SHK 20-200/12 + L10.1”.

Pipe-length (m)	Fill amount (kg)	m _c (kg) ¹	Minimum floor area (A _{min} h _{inst}) (m ²)	
			H ² =1,0 m	H=1,8 m
≤15	0,00	1,84	No requirements for installation	
16	0,02	1,86	8,10	4,50
17	0,04	1,88	8,19	4,55
18	0,06	1,90	8,28	4,60
19	0,08	1,92	8,37	4,65
20	0,1	1,94	8,45	4,70
21	0,12	1,96	8,54	4,74
22	0,14	1,98	8,63	4,79
23	0,16	2,00	8,71	4,84
24	0,18	2,02	8,80	4,89
25	0,2	2,04	8,89	4,94
26	0,22	2,06	8,98	4,99
27	0,24	2,08	9,06	5,04
28	0,26	2,10	9,15	5,08
29	0,28	2,12	9,24	5,13
30	0,3	2,14	9,32	5,18
31	0,32	2,16	9,41	5,23
32	0,34	2,18	9,50	5,28
33	0,36	2,20	9,59	5,33
34	0,38	2,22	9,67	5,37
35	0,4	2,24	9,76	5,42
36	0,42	2,26	9,85	5,47
37	0,44	2,28	9,93	5,52
38	0,46	2,30	10,02	5,57
39	0,48	2,32	10,11	5,62
40	0,5	2,34	10,20	5,66

¹ - Total refrigerant amount

² - H = installation height to bottom edge of AGS 10 and ventilation holes SHK 20-200.



Caution

When installing AGS 10 below 1.0 m, the minimum floor area should be calculated based on the EN 378-1 standard.

- SHK 20-200 must be set on a solid waterproof base that would keep the weight of the indoor unit. The regulated legs of the heat pump allow for levelling and stable setting of the device.

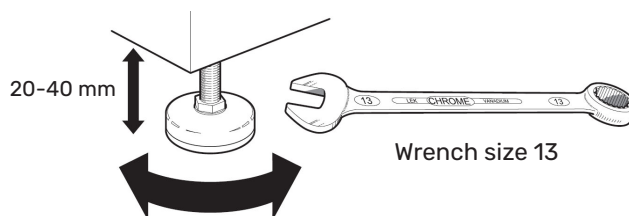

- Since SHK 20-200 has condensation water drainage, the set-up location of the indoor unit should be equipped with a floor drain leading to the sewage system.

Installation location

Leave a free space of 800 mm in front of the indoor unit. There must be a minimum free space of 70 mm behind the indoor unit, however the recommended distance is 150 mm. All servicing of SHK 20-200 can be carried out from the front.

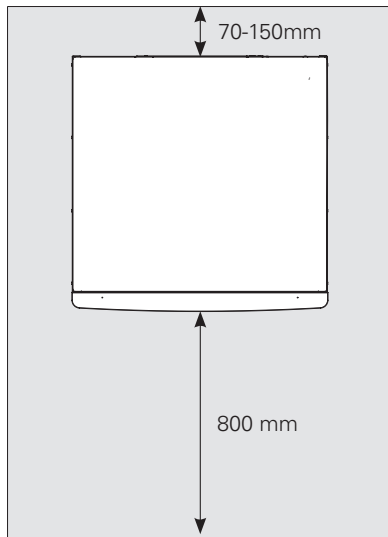

NOTE

If connecting an additional heat source, leave sufficient space behind the appliance for problem-free completion of the connections and future maintenance.

Removing the cover

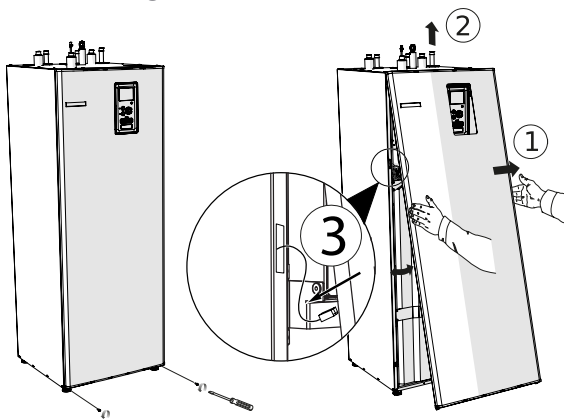

1. Remove screws at the bottom edge of the front cover.
2. Open the cover at the lower edge, taking care to not damage the connecting cables, and then remove the front cover by lifting it up.
3. Disconnect the cable connecting the front cover to the unit.

Supplied components

- Safety group (1 pc.)
- Connector 1" (1 pc.)
- Outdoor temperature sensor / Indoor temperature sensor (1 pc.)
- 230V connection jumper (1 pc.)
- Instalation and user manual
- Reduction 3/8" on 1/4" (SHK 20-200/12)

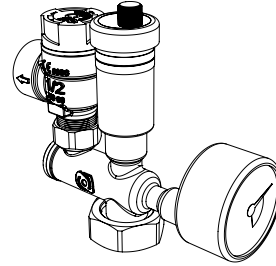

Safety group with safety valve (3 bar), pressure gauge and automatic air vent (1 pc.)

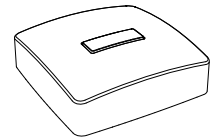

Outdoor temperature sensor (1 pc.)
Connection - see subsection „Additional connections”.

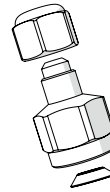

Reduction 3/8" na 1/4"
(1 pc.)
(SHK 20-200/12)

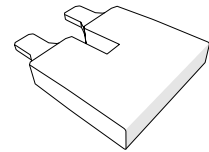

230V connection jumper (1 pc.)

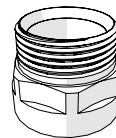

Connector 1"
(1 pc.)



NOTE

The rated opening pressure of the safety valve is 3 bar.

3 Design of the indoor unit

SHK 20-200

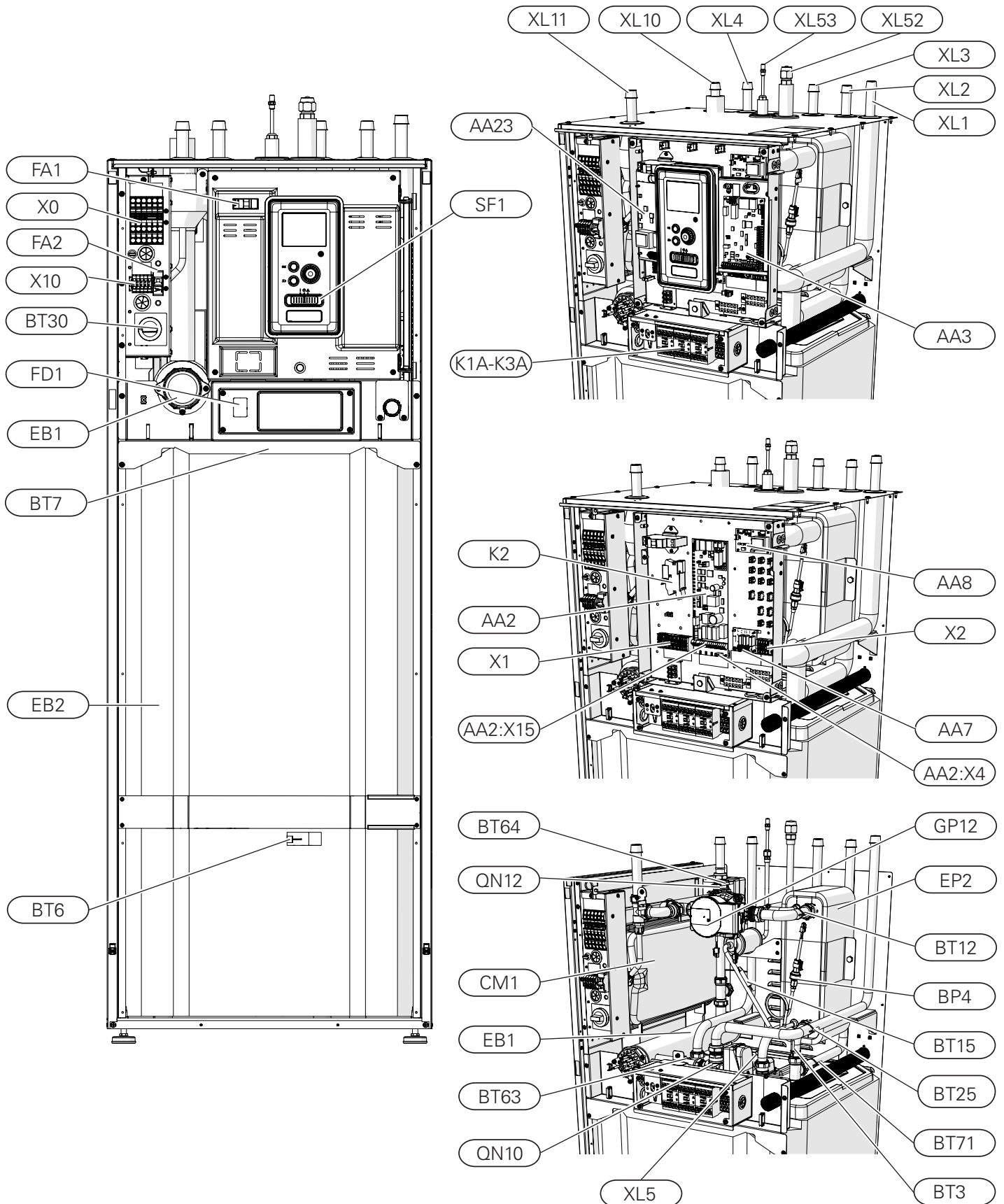

LEGEND

Pipe connections

XL1	Connection, heating medium, supply
XL2	Connection, heating medium, return
XL3	Connection, cold water
XL4	Connection, hot water
XL5	Connection, hot water circulation
XL10	Connection, cooling
XL11	Connection, safety group
XL52	Connection, gas cooling medium
XL53	Connection, liquid cooling medium

HVAC elements

CM1	Expansion vessel, closed
QN10	Reversing valve, hot water/climate system
QN12	Isolation valve, cooling/heating
GP12	Circulation pump
EP2	Heat exchanger

Sensors

BP4	Pressure sensor, high pressure
BT3	Temp. sensor, heating medium return
BT6	Temp. sensor, hot water charging
BT7	Temp. sensor, hot water heater top
BT12	Temp. sensor, condenser out
BT15	Pressure sensor, high pressure
BT25	Temp. sensor, heating medium supply
BT63	Temp. sensor, supply heating medium behind immersion heater
BT64	Temp. sensor, cooling operation system supply
BT71	Temp. sensor, heating medium return

Electrical components

X0	Power terminal - 230V~ / 400V~
X1	Control panel terminal block
X2	Control panel terminal block
X10	Outdoor unit connection terminal - 230 V~
AA2:X4	Terminal block - low voltage
AA2:X15	Terminal block - low voltage
K1A-K3A	Contactors for electric additional heat
K2	Alarm relay
BT30	Standby mode thermostat
AA2	Main board
AA3	Input board
AA23	Communication board
AA7	Extension card
AA8	Karta anody tytanowej
FD1	Thermal circuit breaker
FA1	Miniature circuit breaker (protecting the indoor unit)
FA2	Miniature circuit breaker (protecting the outdoor unit)
EB1	Electric additional heat

Miscellaneous

SF1	Controller switch
EB2	Hot water tank

4 Pipe connections

General information

Pipe installation must be carried out in accordance with the current standards and directives.

The pipe dimensions should not be less than the recommended pipe diameter according to the table below. However, in order to achieve the recommended flow, each installation must be dimensioned individually.

Minimum system flow

The installation must be dimensioned at least to the extent required to manage the minimum defrosting flow at 100% circulation pump operation, see table.

Air/water heat pump	Minimum flow during defrosting (100% pump capacity [l/s])	Minimum recommended pipe dimension (DN)	Minimum recommended pipe dimension (mm)
SHK 20-200/6 + L6.1	0,19	20	22
SHK 20-200/12 + L10.1			

NOTE
An incorrectly dimensioned climate system can result in damage to the appliance and lead to malfunctions.

The system can be used with a low- and medium-temperature climate system. The recommended temperature of the heating medium at the dimensioned outdoor temperature DOT must not exceed 55°C on the supply and 45°C on the return circulation from the climate system. SHK 20-200 can reach up to 70°C when using the electric additional heat or another peak heat source.

An overflow pipe must be routed from the safety valve to a suitable drain. The entire length of the overflow pipe must be inclined towards the floor drain to prevent water pockets and must also be frost-proof. In order to reach maximum system efficiency, we recommend installing SHK 20-200 as close as possible to the outdoor heat pump.

The SHK 20-200 unit is not equipped with a shut-off valve for the climate system. In order to facilitate future servicing, the shut-off valves should be installed on the outside of the indoor unit.

The SHK 20-200 unit can be docked to the central heating, cooling operation and hot water systems. It is absolutely necessary to install the safety assembly on connection XL11.

NOTE
Ensure that incoming heating medium is without pollution. Detailed information can be found in Section 7 „Heating water parameters“.

NOTE
In the installation before the SHK 20-200, a particulate filter should be used, dedicated for heating installations. The filter will protect the unit against pollution.

NOTE
All high points in the climate system must be equipped with air vents.

NOTE
The pipelines need to be flushed out before the indoor unit is connected so that any debris cannot damage component parts.

NOTE
Until the system's heating/cooling circuit has been filled with heating medium, the switch (SF1) in the controller must not be set to "I" or „Δ“. If you do not comply with the above instructions, many components of the SHK 20-200 unit may be damaged.

Expansion vessel

The expansion vessel's volume must be at least 5% of the system's total volume. SHK 20-200 appliances have been equipped with an expansion vessel with a 10 l volume. If the capacity of the built-in expansion vessel is insufficient, an additional expansion vessel meeting the above requirements should be added to the installation.

Table with examples:

Total volume [l] (indoor unit and climate system)	Volume [l], expansion vessel
500	10+15
750	10+25
1000	10+40

The pressure setting in the level vessel should be set according to the maximum height (H) between the vessel and the highest-positioned radiator, see drawing. An initial pressure of 0.5 bar (5 mvp) means a maximum permissible height difference of 5 m.

The maximum volume of the system without a boiler is 220 l at the above initial pressure.

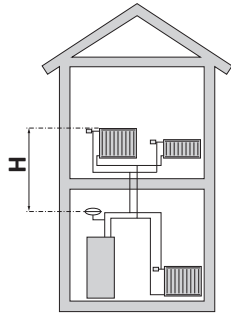

If the standard initial pressure in the expansion vessel is too low, this can be increased by filling it via the installed valve. The expansion vessel's standard initial pressure must be entered in the checklist on page 5.

Any change in the initial pressure affects the ability of the expansion vessel to handle the expansion of the heating medium.

Buffer vessel

The heat pump installation requires an appropriate volume of heating medium (approx. 10l/kW heat pump power) and a minimum, undisturbed flow.

In case of an insufficient amount of heating medium in the installation, an additional buffer vessel must be used, which will ensure adequate system volume, see subsection "Minimum climate system volumes".

An insufficient flow in the central heating system will cause malfunction of the heat pump installation and could lead to serious damage of the product.



NOTE

In order to obtain the minimum undisturbed flow in the climate system, use the appropriate hydraulic solutions (e.g. relief valve, low loss header, parallel buffer and/or open heating loops). Remember to always maintain the minimum required flow in the system - see the subsection "Minimum system flow".



Caution

It is recommended to equip the hot water system with into an expansion vessel. It is also necessary to install a safety valve with the required opening pressure.

Minimum climate system volumes

METROAIR L	L6.1	L10.1
Minimum volume, climate system during under floor cooling	50 l	80 l

System diagram

The SHK 20-200 indoor unit is equipped with a storage tank with a hot water coil, expansion vessel, safety group, electric additional heat, reversing valves, plate heat exchanger, energy meter, electronic circulation pump and controller. Combined together with the METROTHERM SPLIT (METROAIR L) outdoor air heat pump unit, it forms a complete climate system.

The METROAIR L outdoor unit supplies thermal energy for heating domestic water, powering the climate system, heating swimming pools and cooling operation, using free energy contained in the air outside, working efficiently in the low temperature range, as low as -20°C.

The connection of the outdoor unit and the indoor unit SHK 20-200, with a system of pipes filled with refrigerant, protects the connection against freezing in the event of interruptions in the electric power supply to appliances. The system's operations are controlled using an advanced controller.

The control mechanism of SHK 20-200 allows for two cooling operation systems to be used:

- 2-pipe cooling system,
- 4-pipe cooling system.



Caution

SHK 20-200 is equipped with all temperature sensors as standard. In some system layouts, the sensors must be transferred to other parts of the system. For location of the sensors, see the relevant point on docking the system.



Caution

In the event that the water volume of the central heating system is increased using a buffer vessel, you will need to check the system volume and possibly increase the volume of the existing expansion vessel.

Temperature sensor installation on pipe

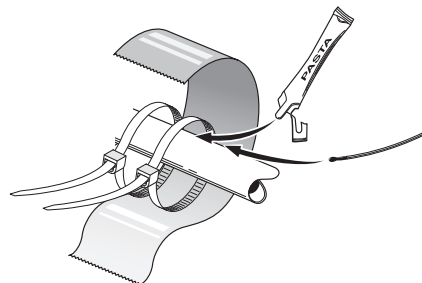

The temperature sensors are fitted using heat conducting paste, cable ties (the first cable tie is secured to the pipe in the middle of the sensor and the other cable tie is mounted approx. 5 cm after the sensor) and aluminium tape. After putting on the ties and the aluminum tape, the sensor should be carefully insulated with aluminium tape.

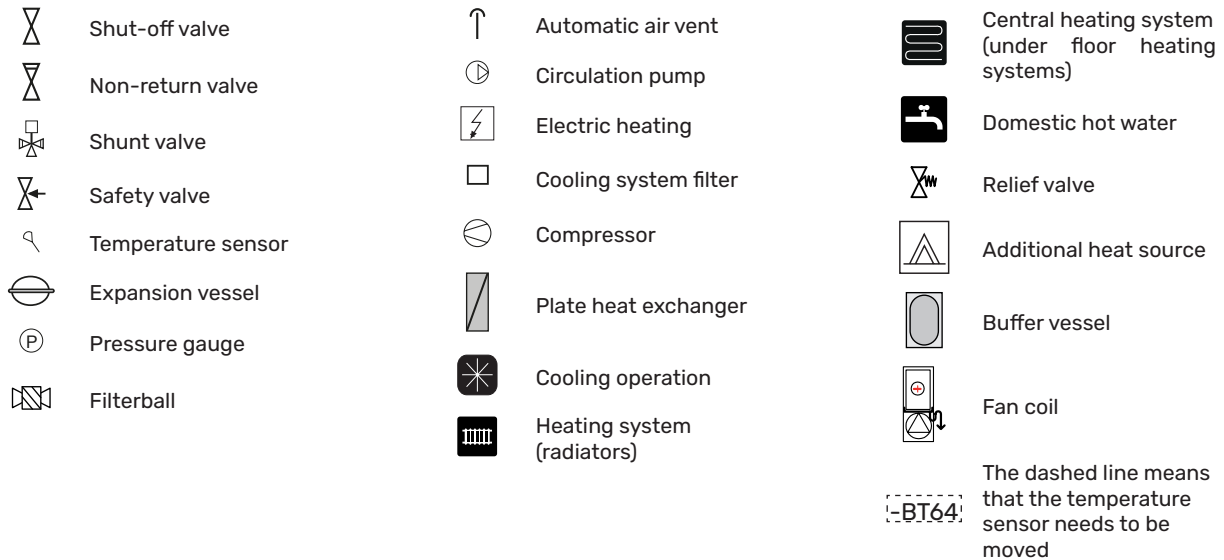

Caution

The installation diagrams presented in the manual are examples and do not include all system components. They do not replace the design of the building's central heating system.

Basic diagram with series-parallel connection of a buffer tank

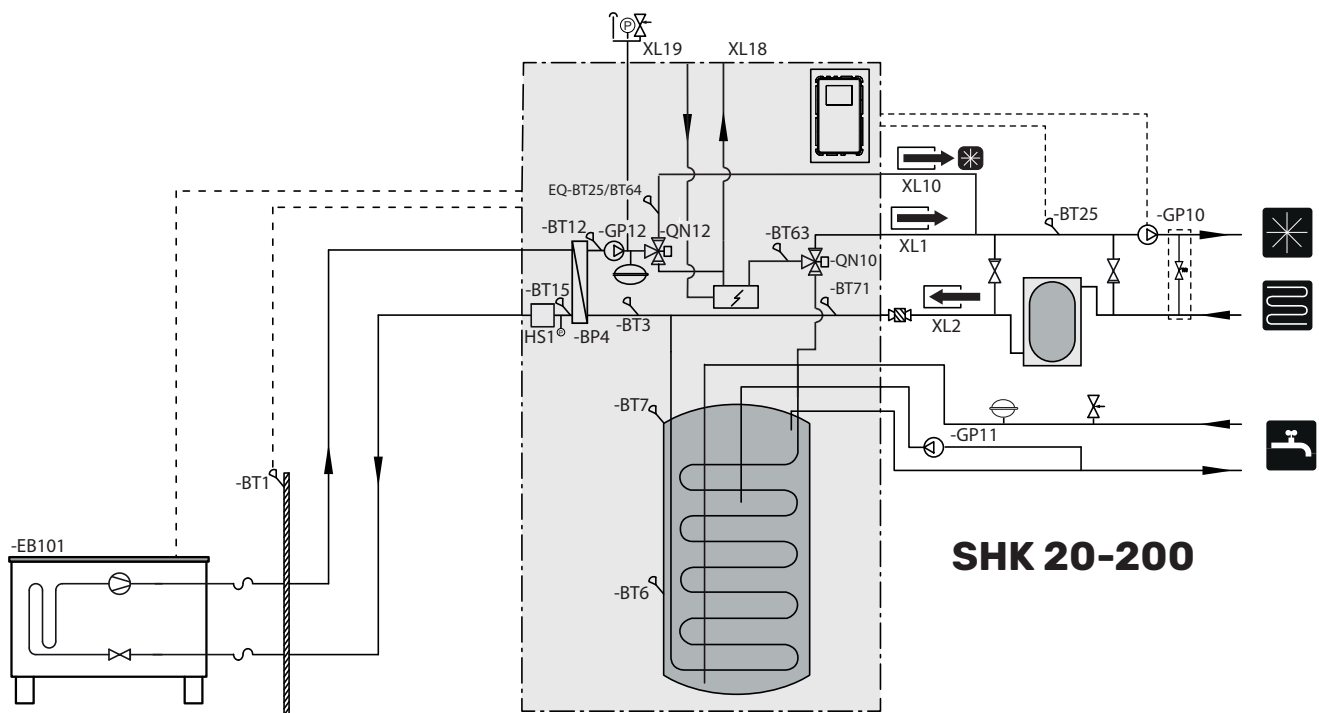

The diagram above is a basic 2-pipe diagram with a buffer. If a buffer is used in the installation, remember to transfer the BT25 sensor to the installation in accordance with the diagram. In a 2-pipe system, the controller supports all sys-

tem components, i.e. GP12, extension modules (additional heating/cooling circuits), etc. The 2-pipe system can be selected in the SERVICE section, menu 5.2.4. Cooling must be activated in menu 5.11.1.1.

Diagram of heating and 2-pipe cooling with series-parallel connection of a buffer tank

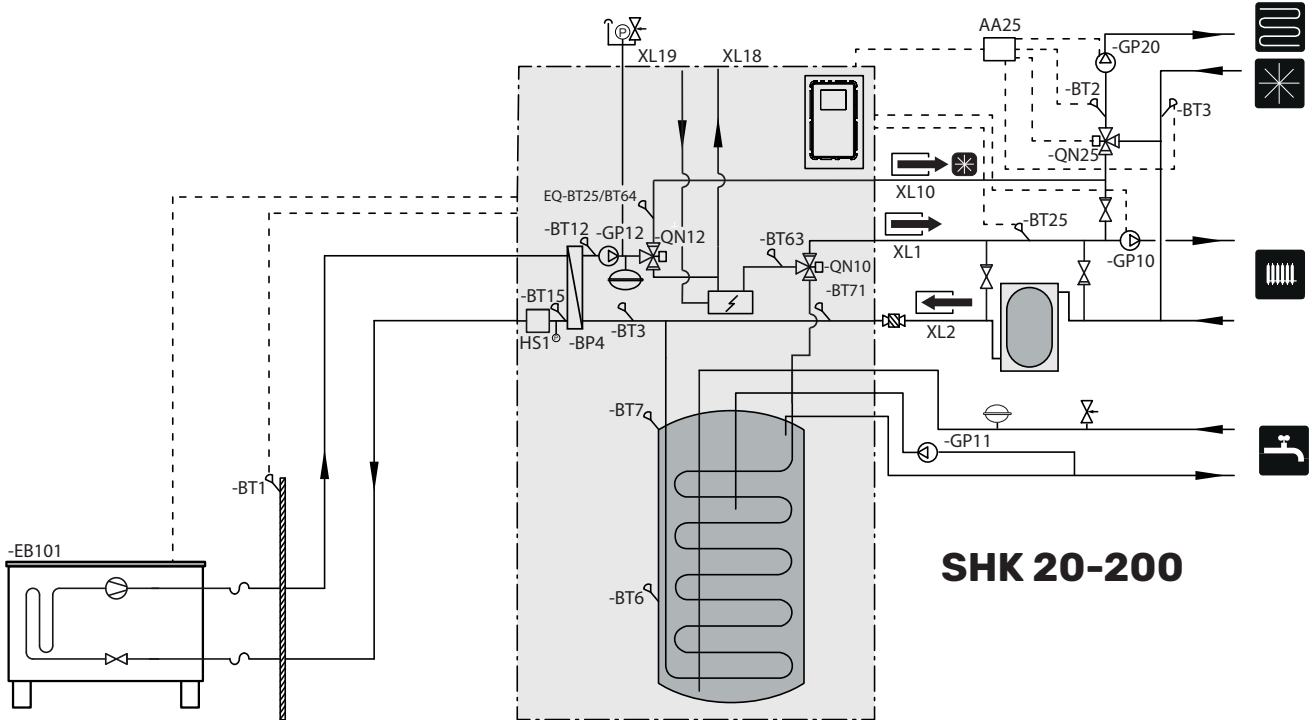

If a buffer is used in the installation, remember to transfer the BT25 sensor to the installation in accordance with the diagram. The principle of operation of the 2-pipe system is to use the same installation for cooling as for heating (diagram of a 2-pipe cooling operation). In a 2-pipe system, the

controller supports all system components, i.e. GP12, extension modules (additional heating/cooling circuits), etc. The 2-pipe system can be selected in the SERVICE section, menu 5.2.4. Cooling must be activated in menu 5.11.1.1.

Diagram of 4-pipe cooling operation

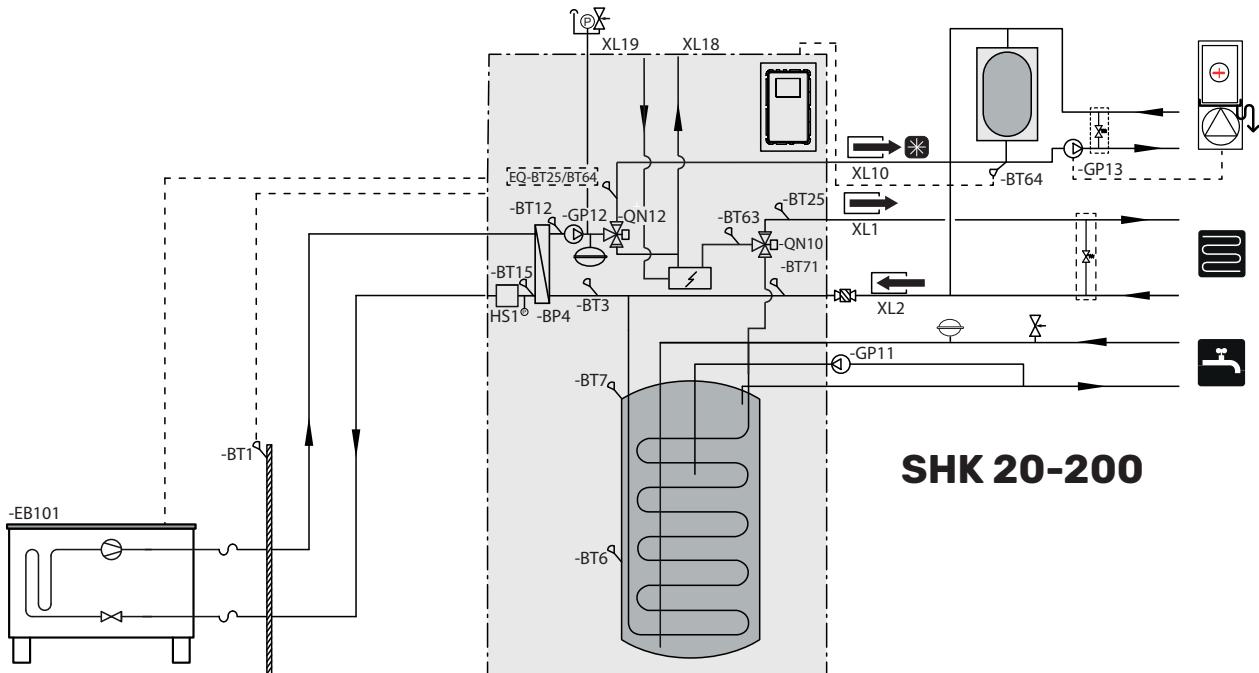

The operating principle of the 4-pipe system is to use separate heating and cooling circuits. In the 4-pipe system, a cooling tank is required. The BT64 sensor should be placed in the buffer vessel or on the cooling flow pipeline.

BT64 is connected at the AUX inputs. Selection of the 4-pipe system can be found in the SERVICE section, menu 5.2.4. Cooling must be activated in menu 5.11.1.1.

Scheme with the connection of an additional heat source

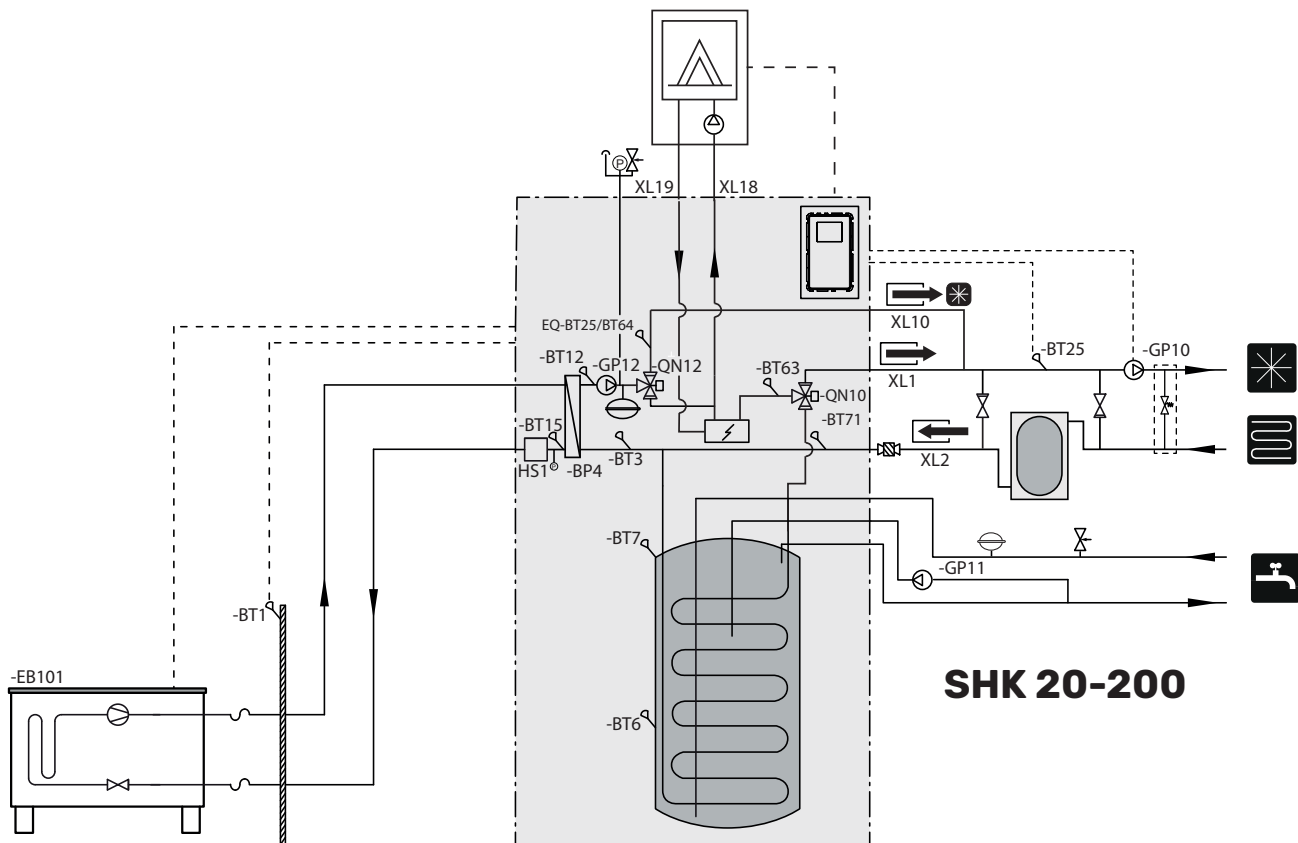

Caution

The maximum recommended power of the additional heat source cannot exceed 15kW.

- It is recommended that you install the SHK 20-200 unit in a room which is equipped with a floor drain and protected against freezing.
- The ground should be of a sufficient load capacity, preferably concrete.
- The SHK 20-200 unit must be positioned with its back against a building wall. The device should not be placed against the walls of rooms in use where noise could be a problem.
- The appliance can be levelled using the adjustable feet.
- Route pipes so they are not adjacent to the wall of a bedroom or living room where noise could be a problem.
- Ensure that there is approx. 800 mm free space in front of and 500 mm above the appliance to facilitate any future servicing.

Recommended order of assembly

1. Dock the SHK 20-200 unit to the central heating system as well as the cold and hot water pipelines.
2. Install refrigerant pipes.
3. Connect the current sensors, outdoor temperature sensor, the lines between SHK 20-200 and METROAIR L, as well as the communication and power supply.
4. Connect the electric power supply (230V or 400V) to the SHK 20-200 unit.
5. Proceed according to the commissioning instructions in the section Commissioning and adjusting.

Pipe connections

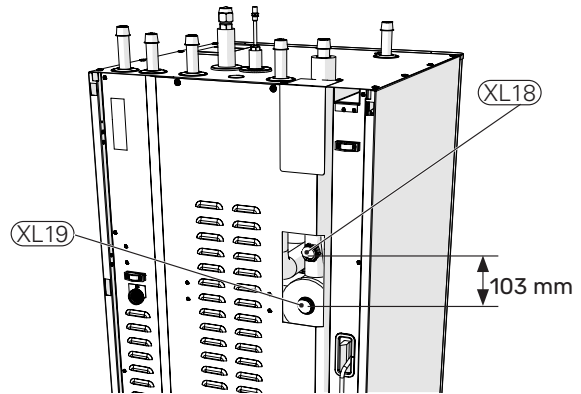
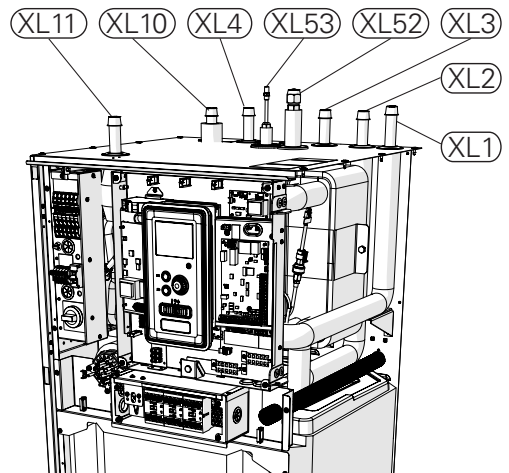
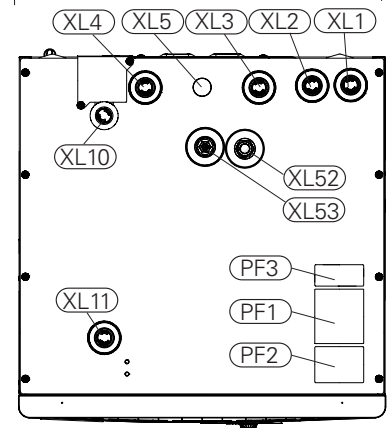
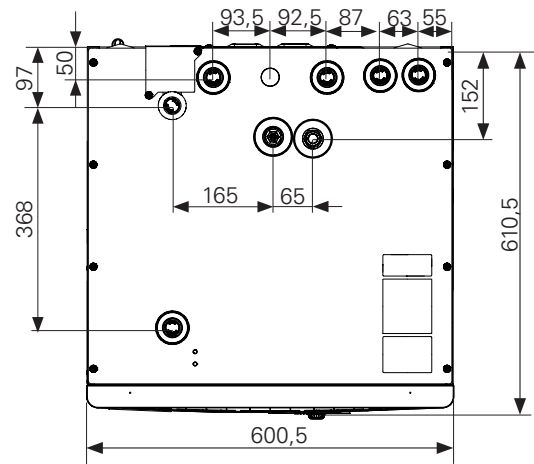
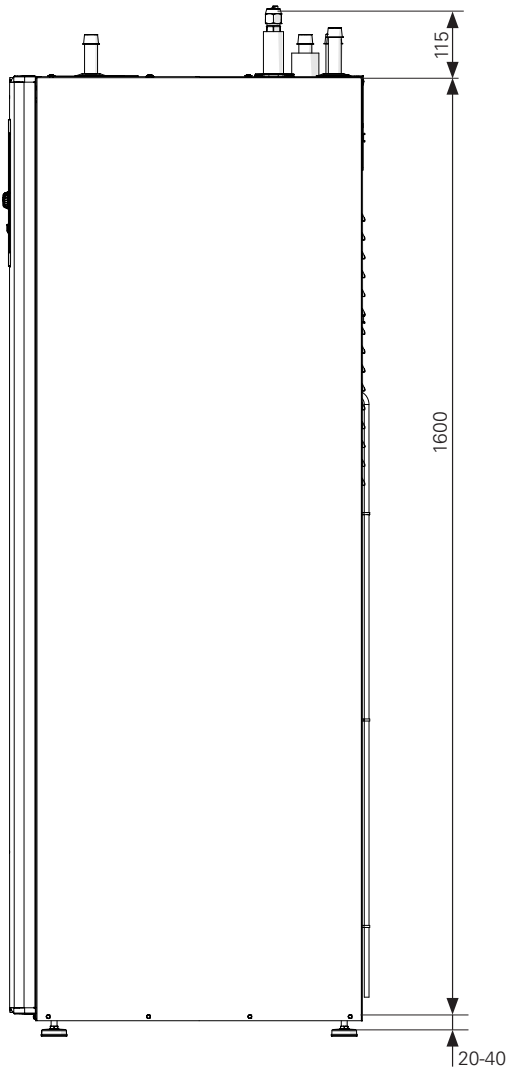

Pipe connections

- XL1 Connection, Heating medium supply Ø22 mm
- XL2 Connection, Heating medium return Ø22 mm
- XL3 Connection, cold water Ø22 mm
- XL4 Connection, hot water Ø22 mm
- XL5 Connection, circulation Ø15 mm
- XL10 Connection, cooling Ø22 mm
- XL11 Connection, safety group Ø22 mm, manometer
- XL52 Gas cooling medium
Connection 1/2" (SHK 20-200/6)
Connection 5/8" (SHK 20-200/12)
- XL53 Liquid cooling medium
Connection 1/4" (SHK 20-200/6)
Connection 3/8" (SHK 20-200/12) - 1/4" adapter for L10.1 units included.
- XL18 Connection, return to an additional heat source Ø22 mm
- XL19 Connection, supply from additional heat source Ø22 mm

Other information

- PF1 Serial number
- PF2 Plate with the designation of the hydraulic connections
- PF3 Warning plate

Docking the indoor unit

Docking the climate system

The pipe connections of the climate system are made from the top of the appliance.

- All required safety devices and shut-off valves must be fitted as close to the SHK 20-200 unit as possible.
- Vent valves must be installed when necessary.
- The safety group with the pressure gauge and air vent on the central heating circuit, as well as the safety valve on the hot water system must be fitted to the appropriate connections XL 11 and XL 3. To prevent air pockets from forming, the overflow pipe must be inclined in its entire length from the safety valve and must also be frost proof.
- When connecting to the installation (where all radiators / underfloor heating circuits are equipped with thermostatic valves or solenoid valves), appropriate hydraulic solutions should be used to obtain a minimum undisturbed flow in the heating system (e.g. excess-relief valve, low loss header, buffer in parallel or open heating loops). Remember to always keep the minimum required flow and volume of the system - see the sections "Minimum system flow" and "Buffer vessel".

NOTE
The term "heating system", as used in this installation and operation manual, shall mean the heating or cooling system supplied with a hot or cold medium from the SHK 20-200 module for heating or cooling purposes.

Caution
Suitable safety valve must be installed directly on the cold water supply line to the hot water tank. Safety valve will protect against excessive increase of pressure. The drain from the safety valve should be discharged into the sewage system or drain.

Connection of the external heat source

An external heat source with a maximum power of 15 kW, e.g. a gas or solid fuel boiler, can be connected to the back of the SHK 20-200 unit after removing the plate blocking access to the connection sockets (picture below). See subsection System diagram.

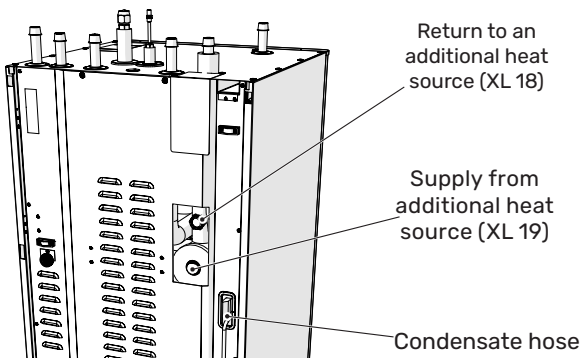

Condensate elimination

The SHK 20-200 unit has a condensate hose to drain the condensation water from the drip tray located under the hot water tank. The pipe drains all of the condensation water away from the appliance, minimizing the risk of damage. This pipe can be extended or replaced if needed.

Connecting refrigerant pipes (not supplied)

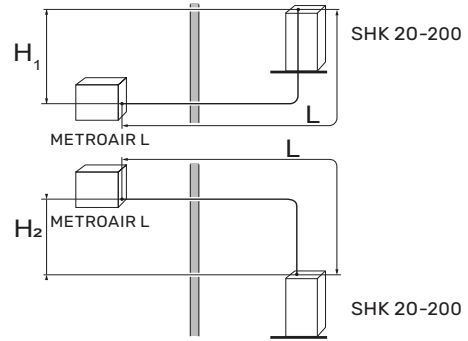

Caution
The outdoor unit, filled with refrigerant at the factory, allows for the use of refrigerant pipes (size L) between the outdoor unit and the indoor unit measured with a pipe length of $L = 15\text{m}$. For maximum allowable refrigerant piping lengths, see the table below.

To properly top up the refrigerant, see the section "Filling the system with refrigerant".

METROAIR L

Refrigerant pipes must be installed between the external module METROAIR L and SHK 20-200. The installation must be executed according to the applicable standards and directives.

PARAMETERS

	unit	SHK 20-200	
		-6	-12
Max. length, refrigerant pipe, one way (L)	m	30	40
Max height difference, when SHK 20-200 is placed higher than METROAIR L (H_1)	m	20	15
Max height difference, when SHK 20-200 is placed lower than METROAIR L (H_2)	m	20	30

- The connection between the outdoor unit and the indoor unit must ensure free flow of the refrigerant.

Refrigerant connection pipeline specification

L6.1

	Gas pipe (Ø ext.)	Liquid line (Ø ext.)
Pipe dimensions	Ø12,7 mm (1/2")	Ø6,35 mm (1/4")
Connection	Connection - (1/2")	Connection - (1/4")
Material	Copper quality SS-EN 12735-1 or C1220T, JIS H3300	
Minimum wall thickness	1,0 mm	0,8 mm

L10.1

	Gas pipe (Ø ext.)	Liquid line (Ø ext.)
Pipe dimensions	Ø15,88 mm (5/8")	Ø6,35 mm (1/4")
Connection	Connection - (5/8")	Connection - (1/4")
Material	Copper quality SS-EN 12735-1 or C1220T, JIS H3300	
Minimum wall thickness	1,0 mm	0,8 mm

- Carry out the pipe installation when the service valves (QM35, QM36) are closed.
- Remove the side panel from METROAIR L during installation to facilitate access.

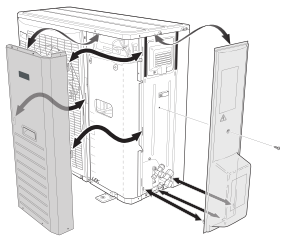

- Take care to ensure no water or pollutants enter the refrigerant connection pipe. Pollutants in the pipes risks damage to the heat pump.
- Bend the pipes with the maximum bending radius (at least R100-R150). Do not bend the pipes repeatedly. Use a bending machine.
- The connection of refrigerant pipes to the outdoor unit and the indoor unit should be made with flared connections after removing the production ends.
- L10.1: Use the 3/8" to 1/4" adapter included with SHK 20-200/12. Not forgetting to put the gasket on. The drawing below shows how to install the adapter.

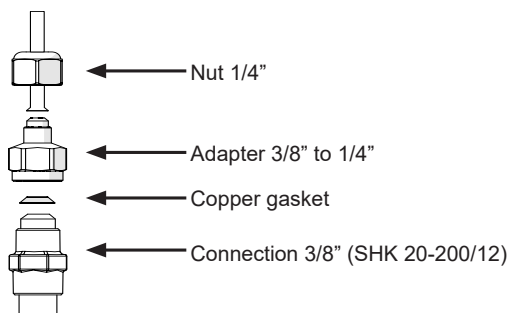

Caution

The SHK 20-200/12 unit is equipped with a 3/8" to 1/4" liquid connection adapter (XL53). The adapter should be used when the control panel is connected to the L10.1 Split outdoor unit.

- Make and connect the flare-connection and tighten with the appropriate torque using a torque wrench. Use the appropriate tightening angle, if a torque wrench is not available.

External diameter, copper pipe (mm)	Tightening torque (Nm)	Tightening angle (°)	Recommended tool length (mm)
Ø6,35	14-18	45-60	100
Ø9,52	34-42	30-45	200
Ø12,7	49-61	30-45	250
Ø15,88	68-82	15-20	300

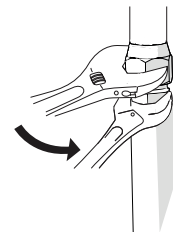

NOTE

Gas shielding must be used when soldering.

Flare connections

Expansion:



External diameter, copper pipe	A (mm)
Ø 6,35 (1/4")	9,1
Ø 9,52 (3/8")	13,2
Ø 12,7 (1/2")	16,6
Ø 15,88 (5/8")	19,7

Ejection:

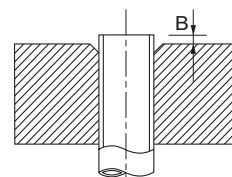

External diameter, copper pipe (mm)	B, using the tool R32 (mm)	B, using the conventional tool (mm)
∅ 9,52 (3/8")	0,0-0,5	0,7-1,3
∅ 15,88 (5/8")		
∅ 6,35 (1/4")		1,0-1,5
∅ 12,7 (1/2")		

Pressure test and leak test

Both SHK 20-200 and METROAIR L are factory tested for pressure and leakage, but the refrigeration pipe connections between appliances should be checked for leakage after installation.



NOTE

The pipe connection between the indoor unit and the outdoor unit must be leak tested. Then create a vacuum for the completed pipeline after finishing installation, in accordance with the applicable regulations. Only nitrogen must be used for compression and drying of the completed pipeline.

Vacuum pump

Use a vacuum pump to remove all air. Apply suction for at least one hour and end pressure after evacuation must be 1mbar (100 Pa, 0.75 Torr or 750 micron) absolute pressure. If the system is still damp or leaking, the vacuum will decrease after the draining has finished.

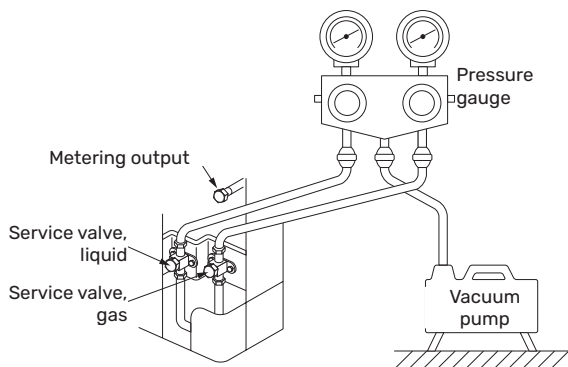

TIP

To achieve a better end result and speed up creation of the vacuum, please follow the below points:

- The pipelines should have the correct diameter and length.
- Drain the system to 4 mbar and fill it with dry nitrogen to atmospheric pressure.

Filling the system with refrigerant

- METROAIR L is delivered complete with the refrigerant required for the installation of refrigerant pipes with lengths of up to 15 m on either side. If the length of the refrigerant pipes exceeds 15 m, extra refrigerant must be added in the amount of 0.02kg/m for SHK20-200/6 or 0.06 kg/m for SHK 20-200/12.



Caution

For installations with refrigerant pipes up to 15 m in length, no extra refrigerant in addition to the provided amount needs to be added.

When connecting the pipes, carrying out pressure tests and leak tests, and creating the vacuum, remember to keep the service valves (QM35, QM36) closed. In order to fill the pipes of SHK 20-200 with refrigerant, they must be reopened.

Insulating refrigerant pipes

- Refrigerant pipes (both liquid and gas) must be insulated for the purpose of thermal insulation and in order to avoid condensation.
- Use insulation that can withstand at least 120°C.

Principle:

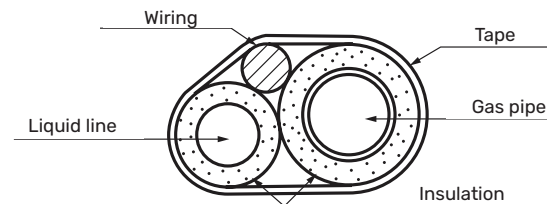

Connections:

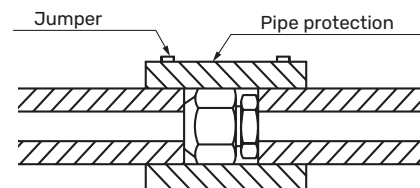

Caution

All connections and work related to the refrigeration system must be carried out by a person with the proper authorisations and certificates.

INSTALLATION REQUIREMENTS

Indoor unit SHK	SHK 20-200/6	SHK 20-200/12
Compatible outdoor module	L6.1	L10.1
Requirements		
Max pressure, climate system	0,3 MPa (3 Bar)	
Highest recommended supply / return temperature at dimensioned outdoor temperature	+55/+45°C	
Max. temperature in the unit SHK	+70°C	
Max flow line temperature with compressor	+58°C	+60°C
Min supply temperature cooling	+7°C	
Max supply temp. cooling	+25°C	
Min flow, climate system, 100 % circulation pump speed (defrosting flow)	0,19 l/s	
Recommendations		
Min volume, climate system during under floor cooling*	50 l	80 l
Max flow, climate system	0,29 l/s	0,38 l/s
Min flow, heating system	0,09 l/s	0,12 l/s
Min flow, cooling system	0,11 l/s	0,16 l/s

* Refers to volume associated with undisturbed flow.

Connection options

Docking the indoor unit

The SHK 20-200 unit is not equipped with a shut-off valve for the central heating system, it must be installed on the outside of the indoor unit to allow any future servicing.

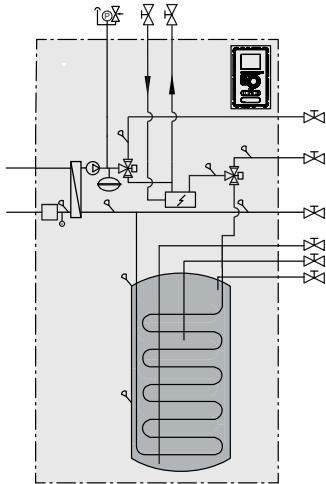

Docking without heat pump

It is not necessary to change the configuration of the hydraulic connections for the indoor unit to work independently without the outdoor unit. The unit is equipped with an additional heater that can be used as the main heat source when there is no outdoor unit.

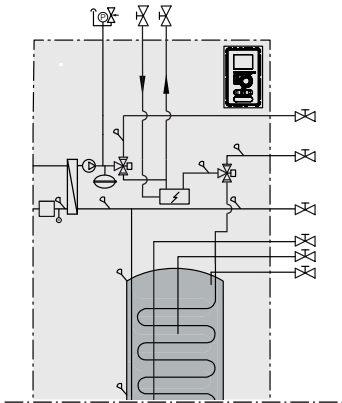

Connecting cold and hot water

The hot water tank should be connected to a water supply system with water pressure of min. 1 bar, max. 10 bar. If the pressure at the cold water inlet to the tank is higher than the permissible level, use a pressure reducer. During heating of the water in the tank, the pressure increases, which is why each tank must be equipped with the appropriate safety valve, installed on the cold water supply, which will protect the tank against an excessive increase in pressure. If using hot water circulation, see subsection "Hot water circulation".

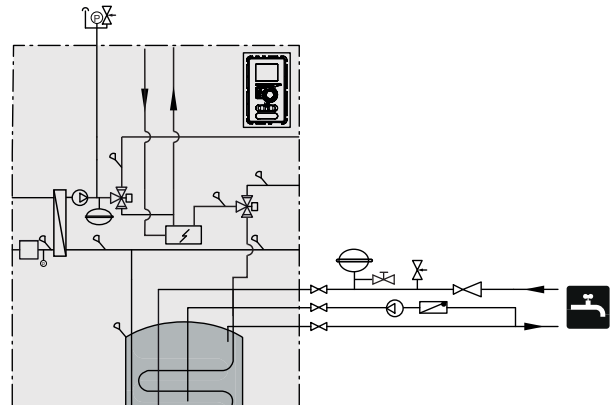

NOTE
It is absolutely necessary to install a properly selected safety valve on the cold water supply pipe.

NOTE
Do not use the appliance if the safety valve is blocked /damaged.

NOTE
It is forbidden to install any constrictors (e.g. reducers, particle filter, etc.) and shut-off valves between the storage tank and the safety valve. Only fitting a tee with a draining valve and a tee with an expansion vessel is permitted.

Docking the climate system

When connecting to a system with thermostatic valves on all radiators/underfloor heating circuits, use the appropriate hydraulic solutions which ensure the proper heating medium volume and minimum, undisturbed flow. See the subsection "Buffer vessel".

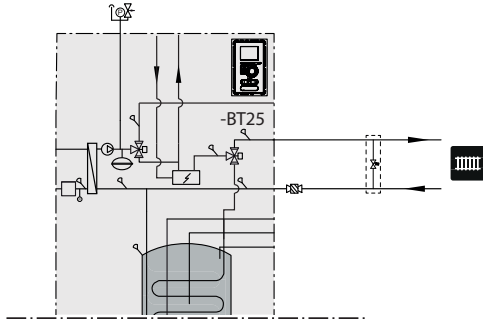

Connecting the 2-pipe cooling operation system

In the 2-pipe cooling operation system, the sensor BT64 / EQ-BT25 assumes the function of sensor BT25. Degree minutes are counted according to EQ-BT25. The BT25 sensor should be moved to the installation according to the diagram.

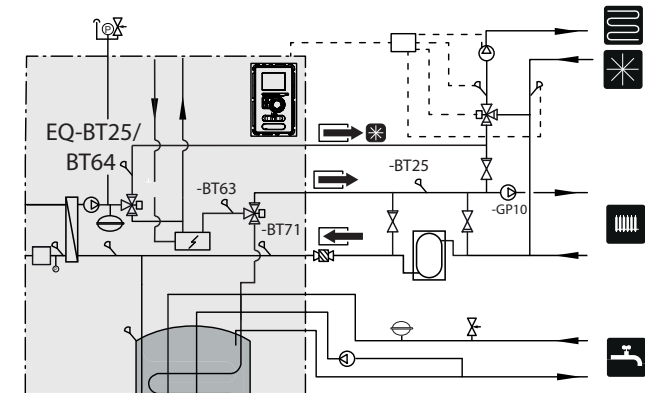

NOTE
The hydraulic system should be suitable for heating and cooling and have appropriate thermal insulation (allowed for cooling).

Connecting the 4-pipe cooling operation system

The 4-pipe system requires an additional cooling buffer vessel. Sensor BT64 must be transferred to the buffer vessel. Degree minutes for heating are counted according to BT25. Degree minutes for cooling operation are counted according to BT 64.

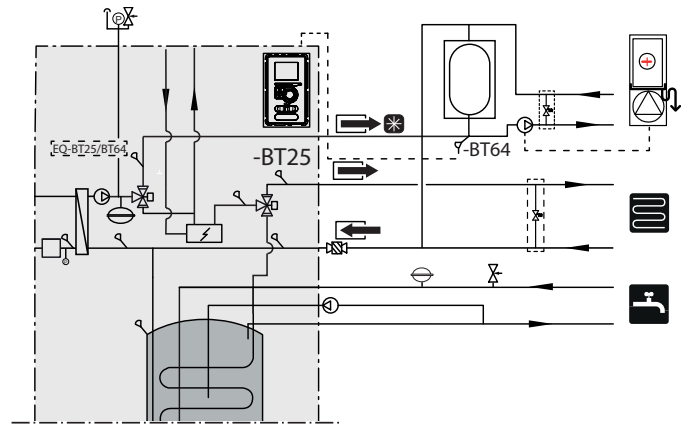

NOTE
The heat pump should have cooling insulation and working in an intermittent mode.

Docking an additional climate system

The system can be expanded to include additional heating/cooling circuits, provided an additional accessory board is used. Once the AXC 30 card or ready-to-use ECS 41 kit has been put into use, an additional heating/cooling circuit can be activated using the controller.

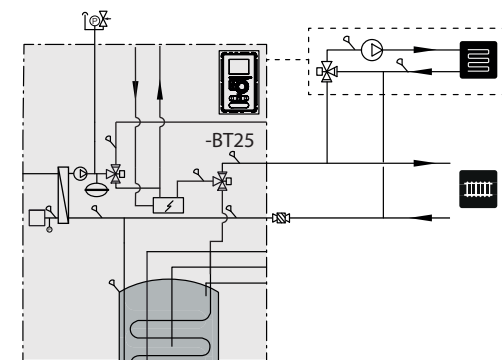

Additional accessories and the connection options and methods for these are described in the instructions for AXC 30 and ECS 41.

DHW circulation

NOTE
 If connection AA3: X7 is used for another purpose, an additional AXC 30 is required to connect the hot water circulation pump control.

The SHK 20-200 have possibility to connect DHW circulation. The circulation connection (XL5) is located at the top of the tank.

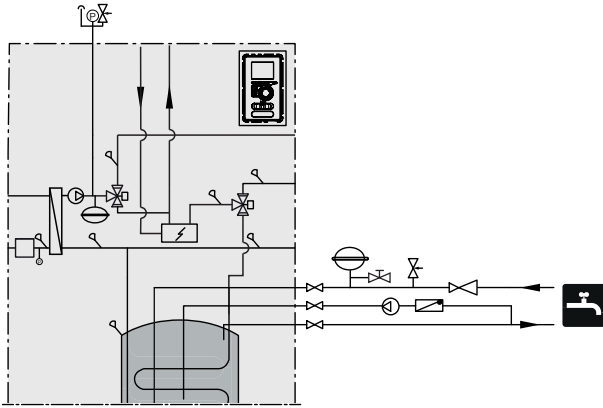

To connect the circulation:

1. Remove the XL5 plug from the top of the housing.

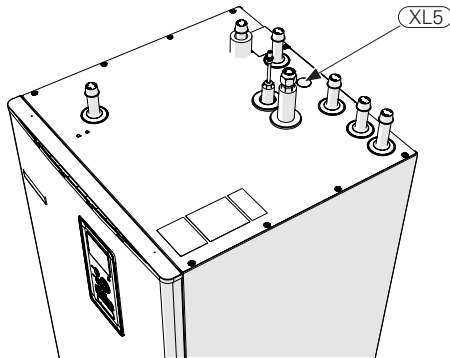

2. Remove the front panel, then move the control box to the right to gain access, to the hydraulic connections.

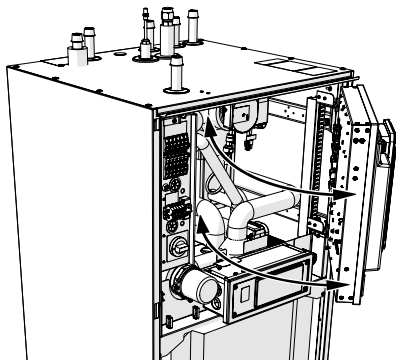

3. Remove the plug from the circulation pipe (XL5).
4. Install the elbow (not included in the SHK 20-200 device) facing the rear housing, on the circulation pipe.

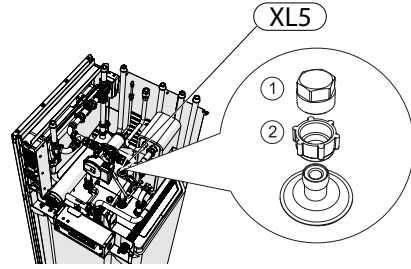

5. Connect the pipe to the elbow, with the dimensions shown in the figure below, leading pipe in the top of the housing, in place of the XL5 plug.
6. Install the circulation pump on the pipe outlet of the SHK 20-200 device, and then connect its control to the controller or AA5 card.
7. Install the control box and the front panel.

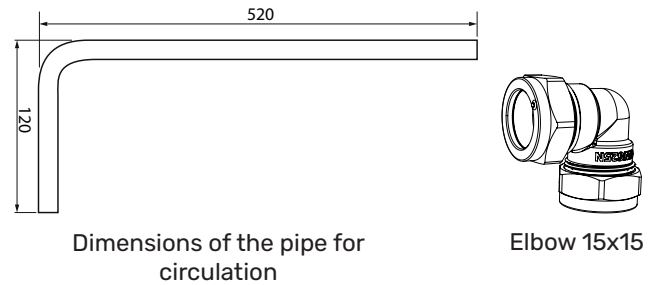

Connecting the control of the hot water circulation pump

The hot water circulation pump can be connected in two configurations:

- to board AA3: X7 (potential free relay; max. 2 A), on terminal block AA3-X7: NO (230 V), and N and PE on terminal block X1.

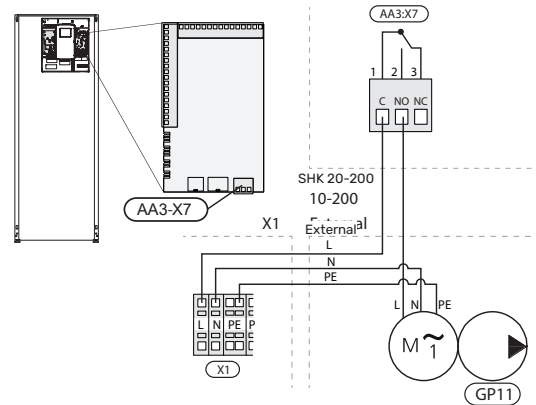

- in case AA3:X7 output is already in use, to accessory board AA5 (not included in SHK 20-200) on block AA5-X9:8 (230V), AA5-X9:7 (N) and X1:PE

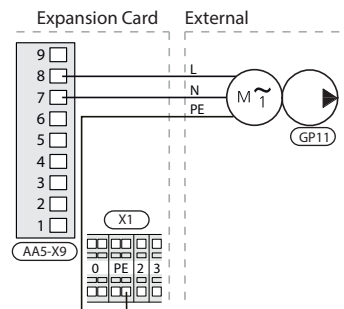

More information in the AXC 30 expansion card manual.

5 METROAIR L outdoor unit

Transport and storage

METROAIR L must be transported and stored vertically.



NOTE

Ensure that the heat pump cannot fall over during transport.

Assembly

- Place METROAIR L outdoors on a solid level base that can take the weight, preferably a concrete foundation. If concrete slabs are used they must rest on asphalt or shingle.
- The concrete foundation or slabs must be positioned so that the lower edge of the evaporator is at the level of the average local snow depth; however, a minimum of 300 mm. Stands and attachments on the page are available in the METROAIR L instruction in the „Accessories“ chapter.
- METROAIR L should not be positioned next to noise sensitive walls, for example, next to a bedroom.
- Also ensure that the placement does not inconvenience the neighbours.
- METROAIR L must not be placed so that recirculation of the outdoor air can occur. This causes lower output and impaired efficiency.
- The evaporator should be sheltered from direct wind, which negatively affects the defrosting function. Place METROAIR L protected from wind against the evaporator.
- Large amounts of condensation water, as well as melt water from defrosting, can be produced. Condensation water must be led off to a drain or similar (see subsection „Condensation water drain“).
- Care must be exercised so that the heat pump is not damaged during installation.

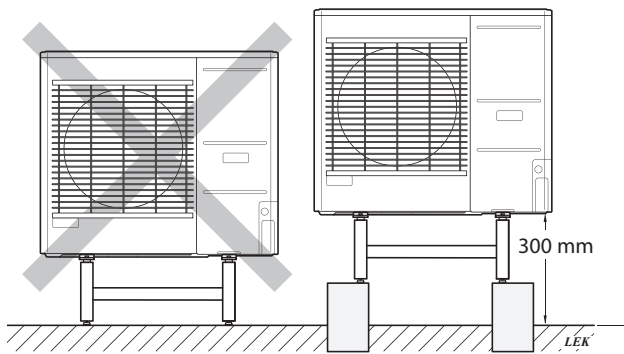

Do not place the METROAIR L heat pump directly on the lawn or other unstable surface.

For details on installing the outdoor unit, refer to the installer manual of the outdoor unit.

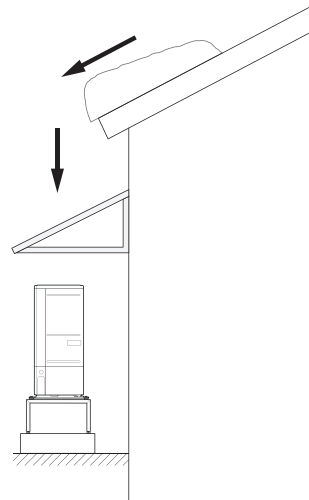

If there is a risk of snow slip from roof, a protective roof or cover must be erected to protect the heat pump, pipes and wiring.

Lift from the street to the set up location

If the base allows, the simplest thing is to use a pallet truck to move the METROAIR L to the set up location.



NOTE

The centre of gravity is offset to one side (see print on the packaging).

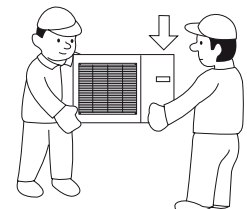
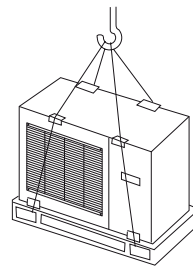

If METROAIR L needs to be transported across soft ground, such as a lawn, we recommend that a crane truck is used that can lift the unit to the installation location. When METROAIR L is lifted with a crane, the packaging must be undamaged and the load distributed with a boom, see the illustration above.

If a crane cannot be used METROAIR L can be transported using an extended sack truck. METROAIR L must be used on the side marked „heavy side“ and two people are required to get the METROAIR L up.

Lift from the pallet to final positioning

Before lifting, remove the packaging and the strap securing the product to the pallet.

Place lifting straps around each foot of the appliance.

Lifting from the pallet to the base requires four persons, one for each lifting strap.

It is not permitted to lift the appliance by anything other than the feet

Scrapping

In case of scrapping, the product is dismantled by performing the above actions in reverse order. Lift by the bottom panel instead of a pallet!

Condensation water drain

Condensation drains out on to the ground below METROAIR L. To avoid damage to the house and heat pump, the condensation must be gathered and drained away.



NOTE

Condensation drainage is important for the operation of the heat pump. The condensation drain must be routed such that it cannot damage the building.



NOTE

Do not connect heating cables with automatic adjustment.



NOTE

The electrical installation and wiring must be carried out under the supervision of an authorised electrician.

- Condensate (50 l / 24 hours) is drained off via the hose to the appropriate drain. It is recommended that the route outside for the condensate is as short as possible.
- The section of the pipe that may be affected by frost must be heated by the heating cable to prevent freezing.
- Route the pipe downward from the METROAIR L heat pump.
- The outlet of the condensation pipe must be at a depth that is frost-free or, alternatively, indoors (subject to local rules and regulations).
- Use a siphon for installations where air circulation may occur in the condensation water drainage pipe.
- The insulation must be tightly fitted to the bottom of the condensation water trough.

Recommended for leading off condensation water

Indoor drain

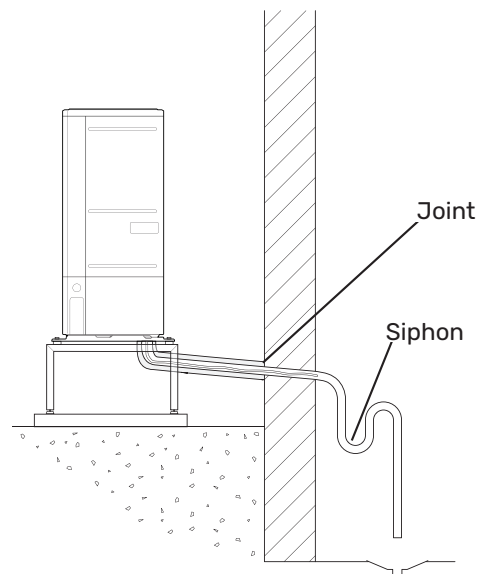

The condensation water is discharged to an indoor drain (subject to local rules and regulations).

Route the pipe downward from the air/water heat pump.

The condensation water drainage pipe must have a water seal to prevent air circulation in the pipe.

Stone caisson

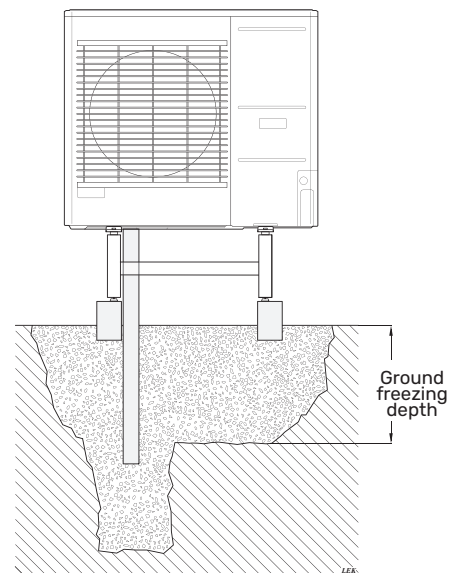

If the building has a basement, use a stone caisson to prevent condensation from damaging the building. Otherwise, the stone caisson can be positioned directly under the heat pump.

The outlet of the condensation water drainage pipe must be at a depth that is frost-free.

Drain into the gutter



NOTE

Bend the hose to create a siphon, see illustration.

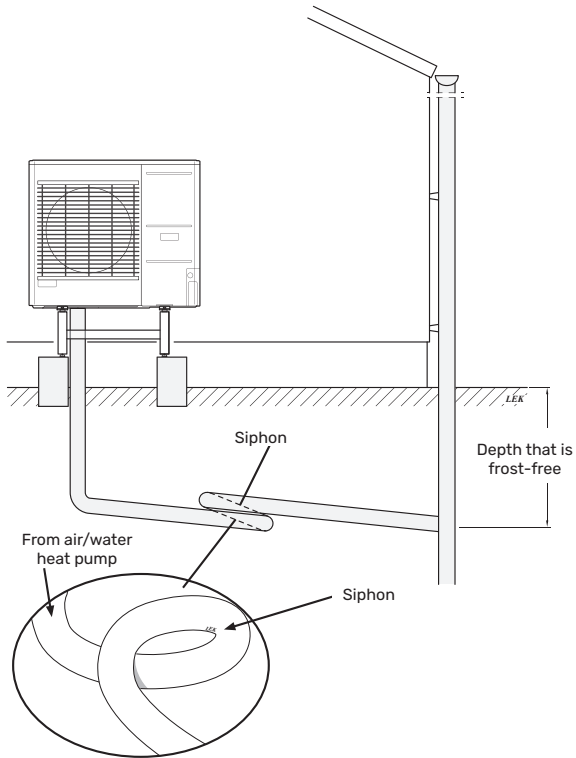

- The outlet of the condensation water drainage pipe must be at a depth that is frost-free.
- Route the pipe downward from the air/water heat pump.
- The condensation water drainage pipe must have a siphon to prevent air circulation in the pipe.
- The installation length can be adjusted by the size of the siphon.



Caution

If none of the recommended options will be used, proper drainage of condensate must be ensured.

Maintenance of METROAIR L

REGULAR CHECKS

Your SPLIT box only requires minimal maintenance. The condensation hose should be checked to ensure that condensation can run out to a drain. If there is any suspicion of leakage, pipe connections on METROAIR L should be checked.

Checking grilles and bottom panel on METROAIR L

Check that the inlet grille is not clogged by leaves, snow or anything else regularly throughout the year.

You should be vigilant during windy conditions and/or in the event of snow as the grilles can become blocked.

Also check that the drain holes in the bottom panel (three) are free from dirt and leaves.

Regularly check that condensation is routed away correctly through the condensation pipe. Ask your installer for assistance if required.

Dimensions

L6.1

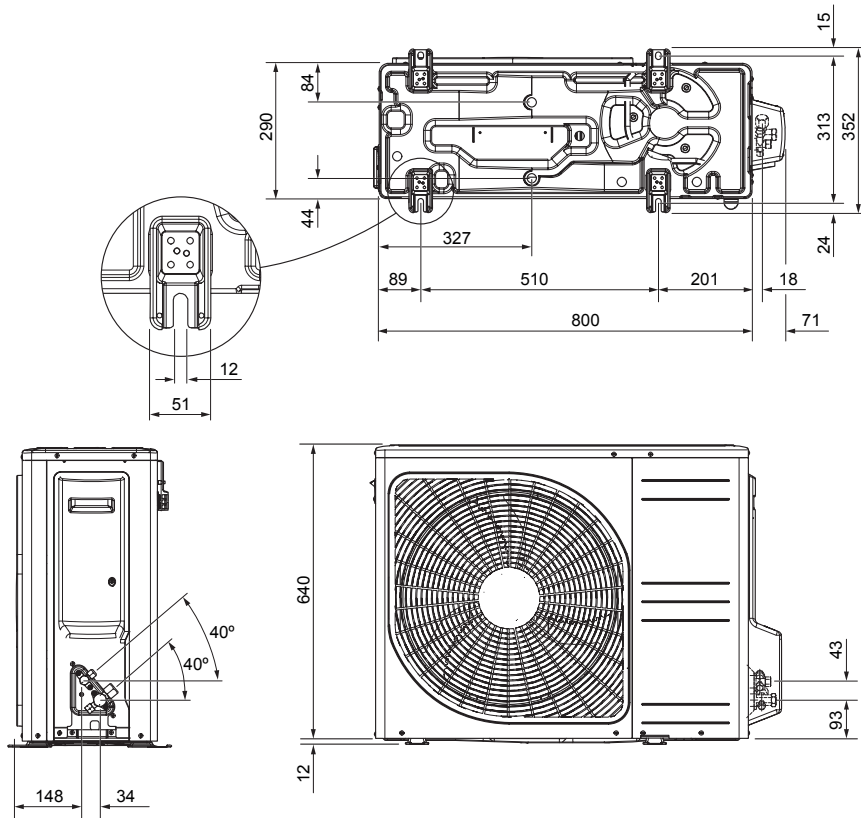

L10.1

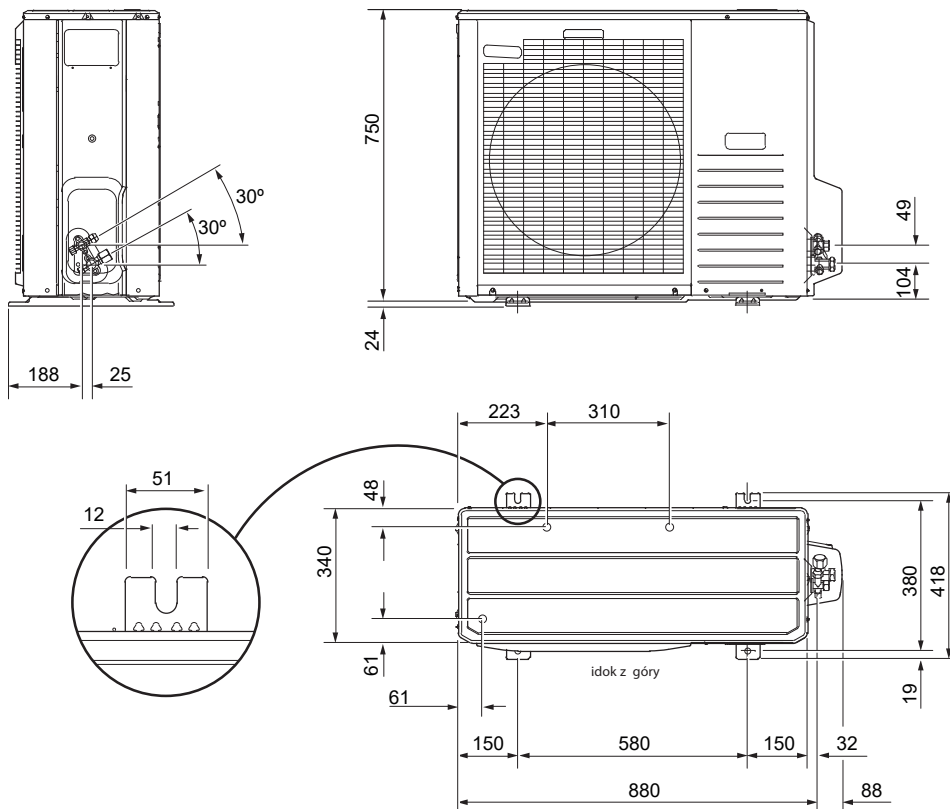

Installation location

The recommended distance between METROAIR L and the building wall should be at least 15 cm. Free space above

METROAIR L should be at least 100 cm. However, the free space from the front must be 100 cm for future servicing.

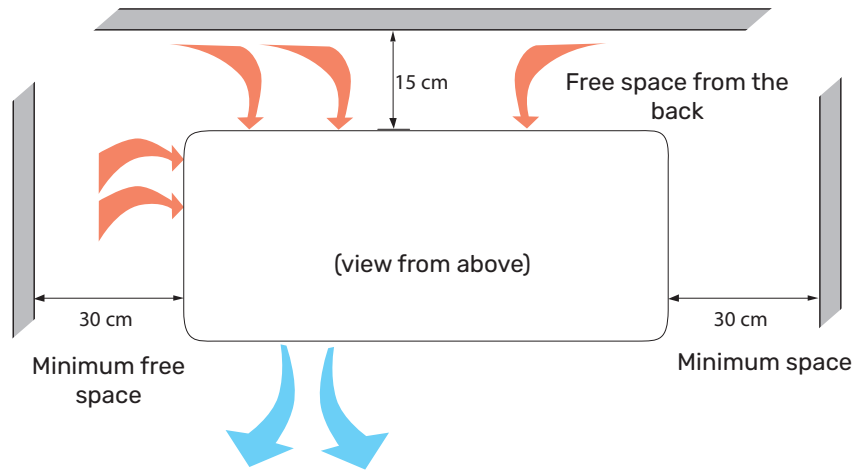

However, the free space from the front must be 100 cm for future servicing.

Sound power levels

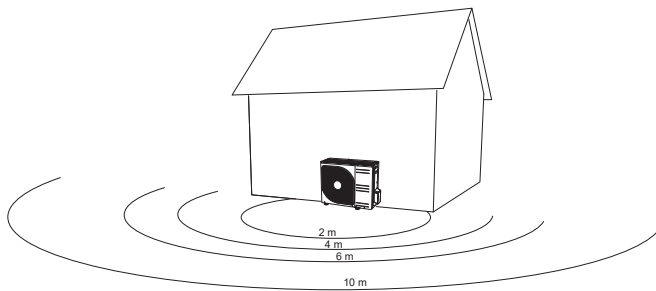

METROAIR L is usually placed next to a house wall, which gives a directed sound distribution that should be considered. Accordingly, you should always attempt to find a placement on the side that faces the least sound sensitive neighbouring area.

The sound pressure levels are further affected by walls, bricks, differences in ground level, etc and should therefore only be seen as guide values.

		Sound power ₁	Sound pressure at distance (m) ₂									
			1	2	3	4	5	6	7	8	9	10
L6.1	Nominal sound value	54	49,0	43,0	39,5	37,0	35,0	33,5	32,1	31,0	29,9	29,0
	Max. sound value	62	57,0	51,0	47,5	45,0	43,0	41,5	40,1	39,0	37,9	37,0
	Max. sound value, silent mode	54	48,0	42,0	38,5	36,0	34,0	32,5	31,1	30,0	28,9	28,0
L10.1	Nominal sound value	54	49,0	43,0	39,5	37,0	35,0	33,5	32,1	31,0	29,9	29,0
	Max. sound value	65	60,0	54,0	50,5	48,0	46,0	44,5	43,1	42,0	40,9	40,0
	Max. sound value, silent mode 60 Hz	54	49,0	43,0	39,5	37,0	35,0	33,5	32,1	31,0	29,9	29,0

¹ Sound power level, LW(A), according to EN12102

² Sound pressure calculated according to directivity factor Q=4

6 Electrical connections

General information

All electrical equipment, except the outdoor temperature sensor, room sensor are already connected at the factory.

- Disconnect the indoor module before performing tests of electrical system insulation in the building.
- If the building is equipped with a differential switch, SHK 20-200 must be equipped with a separate switch.
- The diagram of indoor module connections can be found in section „Electrical wiring diagrams“.
- Do not lay communication and signal cables to external contacts near voltage cables.
- Minimum cross-section of communication and signal cables to external contacts must total 0.5mm² with the length of up to 50 m, for example EKKX or LiYY, or similar.
- The power supply cable should be dimensioned according to the current standards.
- Use the UB1 cable grommet (as marked in the illustration) to lead the cables to the SHK 20-200. In the UB1 grommet, the cables are routed through the entire indoor unit from the rear wall towards the front.

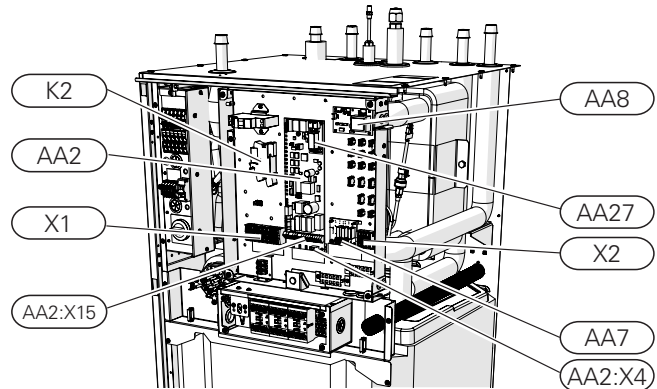
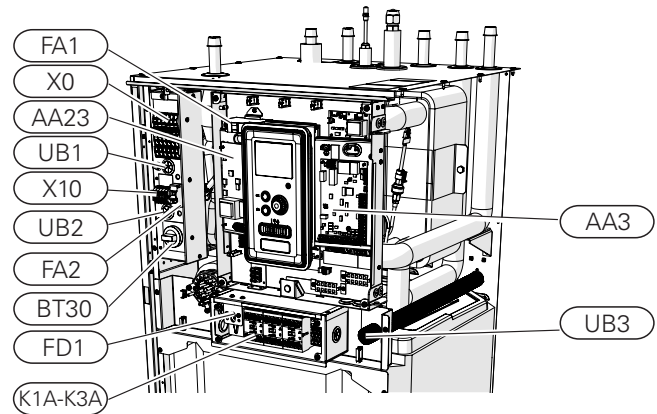

NOTE

The switch (SF1) for the controller must not be set to "I" or "Δ" until the climate system has been filled with heating medium and vented. Otherwise, the thermal circuit breaker, thermostat and the electric additional heat may be damaged.



NOTE

Cut off the power using the circuit breaker before carrying out any servicing. Electrical installation must be carried out in accordance with the current regulations by a person with the proper authorisations and qualifications.



NOTE

When SF1 is set to „Δ“ - the SHK 20-200 unit switches the QN10 valve to the central heating and heating takes place according to thermostat BT30. Hot water is not heated while the switch is set to „Δ“.



NOTE

If the system is operating at "Δ" the temperature on BT30 should be aligned with the operating temperature of the central heating system. If the temperature set on the thermostat is too high, it can damage the system.

X0	Power terminal - 230V~ / 400V~
X1	Control panel terminal block
X2	Control panel terminal block
X10	Outdoor unit connection terminal - 230 V~
FA1	Miniature circuit breaker (for the indoor unit)
K1A-K3A	Electric additional heat contactor
BT30	Standby mode thermostat
AA3	Sensor card
AA23	Communication card
AA7	Relay board
FA2	Miniature circuit breaker (protecting the outdoor unit)
FD1	Thermal circuit breaker STB
UB1-UB3	Cable grommet
K2	Alarm relay
AA2	Main board
AA2:X15	Terminal block - low voltage
AA2:X4	Terminal block - low voltage
AA8	Titanium anode card
AA27	Relay board

Thermal circuit breaker STB

Temperature limiter STB (FD1) cuts off the power supply of the electrical heating module if the temperature increases to the range of approximately 92-6°C.



NOTE

In case of activation of the STB temperature limiter, it must be reported to an authorized service in order to diagnose the possible cause of its activation.

Resetting

The thermal circuit breaker (FD1) is accessible behind the front cover. It is reset by pressing firmly on the button (FD1-SF2) using a small screwdriver. Press the button using max. force 15 N (approx. 1.5 kg).

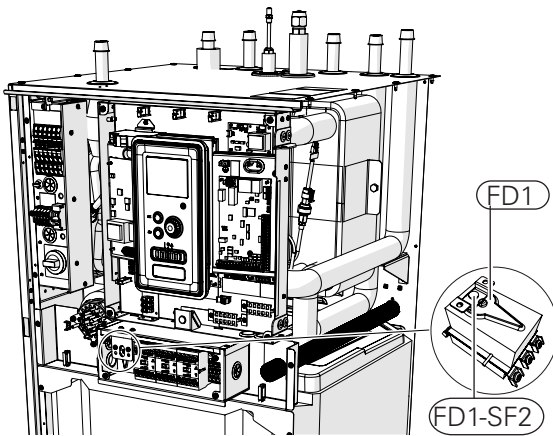

Cable key lock

Use a suitable tool to release/lock the cables in the terminal blocks of the indoor unit.

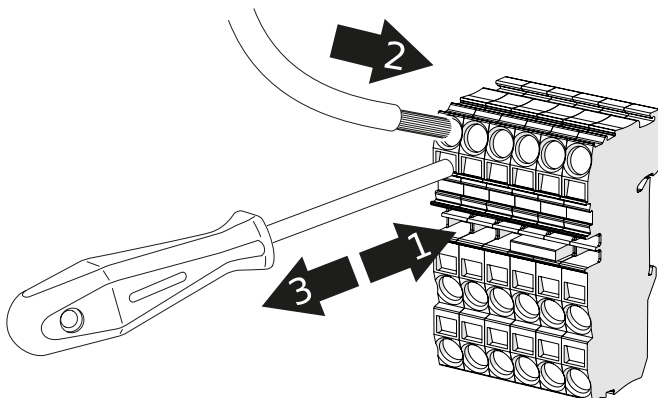

Connections



NOTE

External overcurrent protection should be selected by an appropriately qualified installer, based on the technical data contained in the manual, in accordance with the installed equipment system.



NOTE

The indicated cross-sections of power cables are recommended for cables laid on the wall with a length not exceeding 40 m. The selection of cables/sections and their arrangement should be consulted with a qualified electrician each time.



NOTE

To prevent interference, unshielded communication cables and/or sensor cables to external connections must not be laid at a distance less than 20 cm from voltage cables.



NOTE

The electrical system to which the device will be connected should be built in accordance with current regulations.

Power supply connection 400 V

The power supply connection is connected to terminal block (X0) through the input on the back of the unit (UB1). The cable must be dimensioned according to the applicable standards.

The 400V connection allows for a maximum power of 9kW to the electric additional heat. The connection should be made according to the diagram in the user manual.

Detailed electrical diagram - see subsection "Electrical wiring diagrams".

Diagram - connecting power supply 400 V

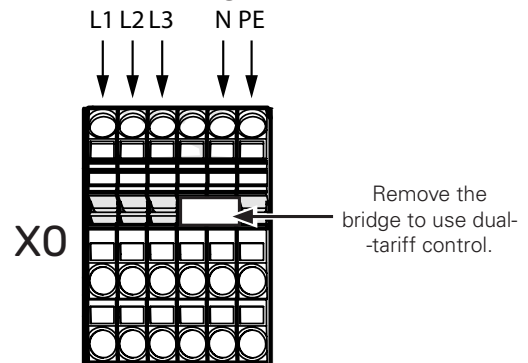

NOTE

If a 400V connection is used, the maximum power of the electric additional heater placed in the SHK 20-200 unit is 9 kW.



NOTE

In the case of dual-tariff control by the power company, it is recommended to connect the neutral wire from the power circuit (meter).

Power supply connection 230 V

The power supply connection is connected to terminal block (X0) through the input on the back of the unit (UB1). The 230V connection allows for a maximum power of 4,5 kW to the additional heating. The connection should be made according to the diagram in the user manual. Detailed electrical diagram - see subsection "Electrical wiring diagrams".

Diagram - connecting power supply 230 V

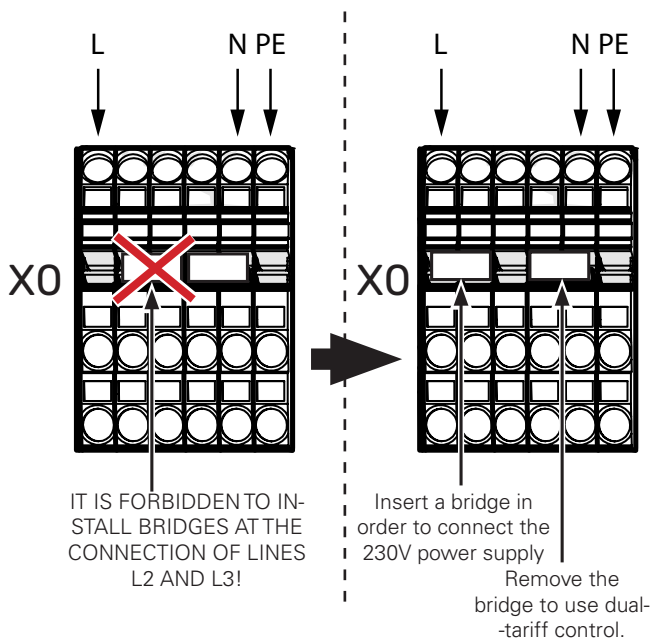

NOTE

When a 230V connection is used, the maximum power of the additional heat used in the SHK 20-200 unit is 4.5kW.



NOTE

In the case of a dual tariff power supply by the power company, it is advisable to connect the neutral wire from the power supply circuit (meter) - particularly when using a 230 V connection.



NOTE

It is forbidden to install bridges at the connection of lines L2 and L3. Otherwise, the appliance and the electrical system may be damaged.

The manufacturer is not liable for any damage caused by failure to comply with the above instructions.

Miniature circuit breaker

The automatic heating control system, the circulation pump and their wiring in SHK 20-200 are internally protected by miniature circuit breaker C10 (FA1). The METROAIR L outdoor unit and accessories are internally protected in SHK 20-200 by miniature circuit breaker B20 (FA2).



NOTE

The electrical installation should also have an additional power switch to disconnect the main power supply to the unit.

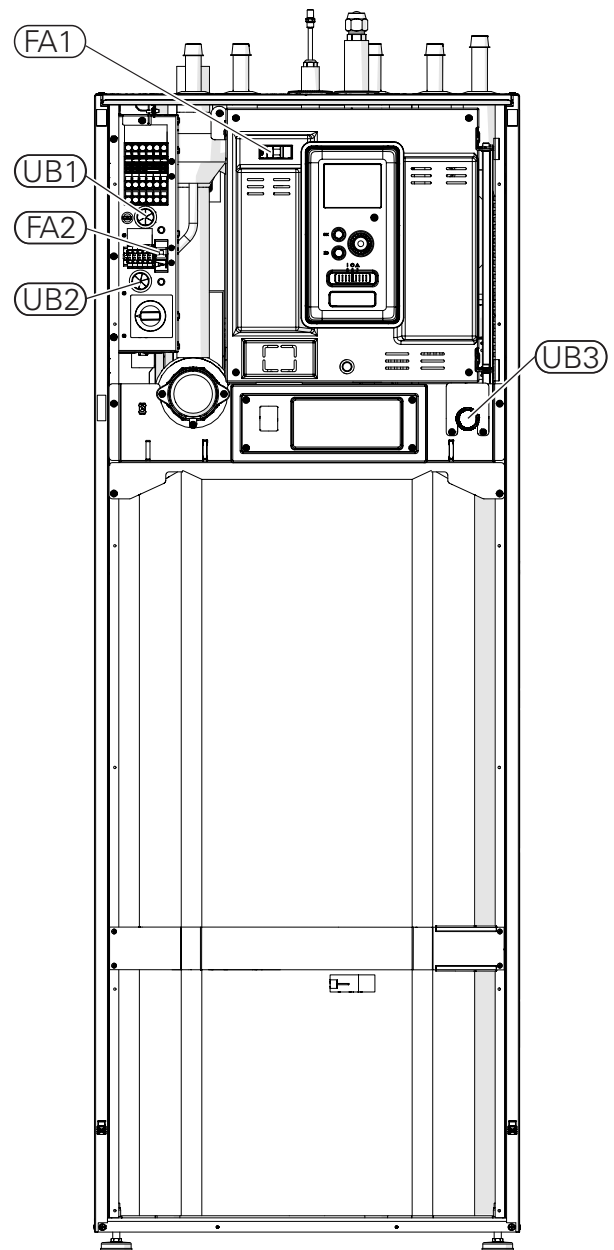

Connecting SHK 20-200 and METROAIR L

The device connecting cable should be connected to the power supply terminal block (TB) in METROAIR L and to the terminal block (X10) in SHK 20-200 .

NOTE

Wiring must be secured so that the terminal block is not under tension. The end of the wire should be 8 mm long without insulation.

METROAIR L

Connect the phase (brown), neutral (blue), communication (black and grey) and protective (yellow-green) conductors as shown in the drawing:

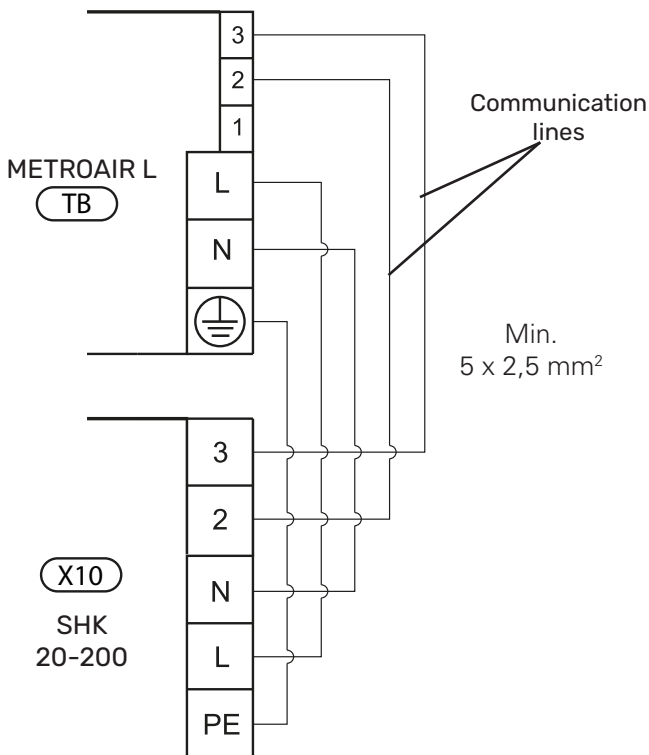

Additional connections

Connecting the outdoor temperature sensor

The outdoor temperature sensor BT1 (included) should be connected to the SHK 20-200 unit via terminal block AA3-X6:1 and AA3-X6:2.

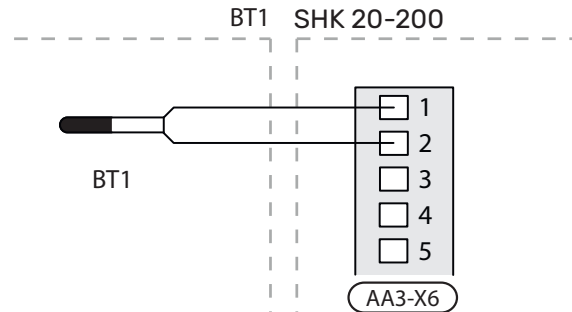

Connecting the indoor temperature sensor

The indoor temperature sensor BT50 (included) should be connected to the SHK 20-200 unit via terminal block AA3-X6:3 and AA3-X6:4.

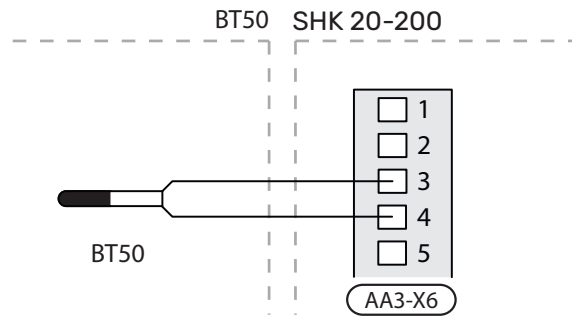

CURRENT SENSORS

When many power consumers are connected in the property at the same time as the electric additional heat is in operation, there is a risk of the property's main fuses tripping. Current meters controls the power steps for the electric additional heat by disconnecting step by step in event of overload in a phase. Reconnection occurs when other current consumption is reduced.

Caution

If current meters are installed, full functionality is obtained by enabling 'detect phase sequence' and changing the fuse size to 20A in menu 5.1.12.

Connecting current sensors



NOTE

If the current value (MENU 5.1.12) is set too low, it may cause the additional heat to be switched off, reduce the heat pump capacity and may affect the efficiency of the compressor.

A current sensor must be installed on each incoming phase conductor into the electrical distribution unit, to measure the current. The electrical distribution unit is an appropriate installation point.

Current meters should be connected to the four-wire cable in the distribution box. Between the housing and SHK 20-200, use a four-wire cable with a cross-section of min. 0.5mm².

Connect the cable to the input board (AA3) on terminal block X4:1-4 where X4:1 is the common terminal block for the three current sensors.

If the current value (MENU 5.1.12) is set too low, it may cause the additional heat to be switched off, reduce the heat pump capacity and may affect the efficiency of the compressor.

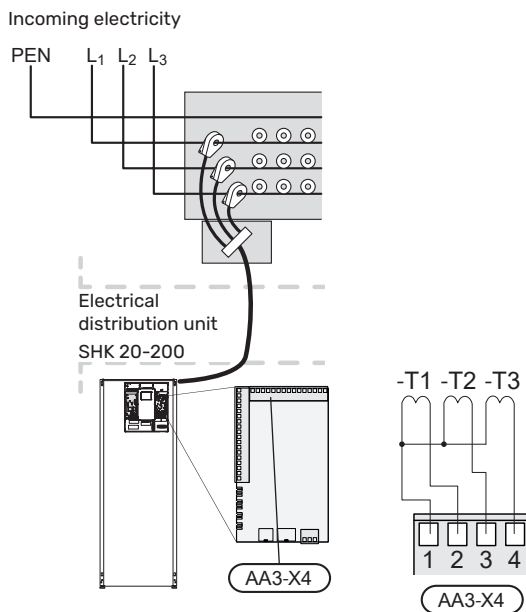

NOTE

If the current value (MENU 5.1.12) is set too low, it may cause the additional heat to be switched off, reduce the heat pump capacity and may affect the efficiency of the compressor.

Settings

Electric additional heat- maximum power

The electric additional heat has a maximum power of 9 kW (400 V) / 4,5 kW (230 V). The power is split into 3 steps. The possible operational power steps are: 3, 6 and 9 kW (400 V) or 1,5, 3,0 and 4,5 kW (230 V). The maximum power step of the immersion heater can be set using menu 5.1.12.

Emergency mode

When the controller is set to emergency mode (SF1 is set to Δ) only the most necessary functions are activated.

- Hot water is not heated.
- Constant temperature in the supply line, more information in the section Emergency mode thermostat.



NOTE

While on emergency mode, it is not possible to heat hot water.

Emergency mode thermostat

The supply temperature in emergency mode is set using a thermostat (BT30). It should be set according to the demands of the heating/cooling circuits in operation. The adjustment range is 5 - 65°C. Please note, however, that for underfloor heating the setting should be min. 20°C, max. 35-45°C to maintain comfort in the room and efficient operation of the system.

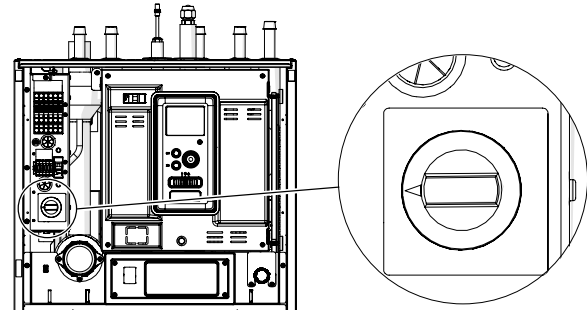

NOTE

The maximum available heater power in emergency mode is 3kW.



NOTE

The temperature on the thermostat must be set according to the system requirements. If the temperature is too high, it can damage the system.

7 Commissioning and adjusting

Preparations

1. Check that the switch for the control module is in position „ ⏻ “.
2. Check whether the drain valve has been completely closed, and whether the temperature limiter has not been activated (FD1).
3. Compatible air/water heat pumps have been listed in the Connection Options section.

Filling and venting

Heating water parameters

If the heating circuits are filled with heating water, the water must comply with the requirements of VDI Guideline 2035 parts 1 and 2.

To prevent corrosion damage, three basic parameters of water composition must be controlled:

1. dissolved oxygen content,
2. electrical conductivity and
3. pH.

Oxygen content and electrical conductivity are related such that lower conductivity allows higher O₂ content without fear of increased corrosion. Similarly, higher conductivity can result in increased susceptibility to corrosion even at relatively low O₂ saturation levels.

The following guidelines are therefore recommended:

4. Heating water with a low salt concentration - i.e. where the electrical conductivity of the system water is less than 100 $\mu\text{S/cm}$ - the dissolved O₂ content should be less than 0.1 mg/l.
5. Heating water with a high salt concentration - i.e. where the electrical conductivity of the system water is between 100 $\mu\text{S/cm}$ and 1500 $\mu\text{S/cm}$ - the dissolved O₂ content should be less than 0.02 mg/l.

In both cases, the pH value of the heating water should remain between 8.2 and 10.

In order to prevent damage due to boiler scale, the following water composition parameters must be controlled:

System thermal output [kW]	System capacity [l/kW]	Alkali earth element content [mol/m ³]	Hardness [°d]
≤ 50	≤ 20	no requirements	no requirements
	from 20 to 50	≤ 2,0	≤ 11,2
from 50 to 200	≤ 20	≤ 2,0	≤ 11,2
	from 20 to 50	≤ 1,5	≤ 8,4

Filling the DHW heater at SHK 20-200

1. Open the hot water tap in the building to the tank.
2. Open the valve cutting off cold water. When doing so, the valve should be completely open.
3. When water starts to flow from the intake point with hot water without air bubbles, the HW tank is full and you can close the intake point.

Filling and venting the climate system and SHK 20-200

1. Open the vent valves at the highest point of the climate system.
2. Set all mixing valves to a position which allows flow in all heating/cooling circuits.
3. Open the valve for filling the climate system and fill it with the heating medium, vent the system.
4. Check the pressure gauge, on which an increase in pressure will be visible. Fill the system to the required pressure (1,5 - 2), then close the filling valve. The maximum operating pressure of the system is 3 bar.
5. Start the climate system circulation pump. The automatic vent valves located on the heating/cooling circuit will begin venting the system.
6. If during venting the pressure falls below 1 bar, extra heating medium must be added to the climate system.

Draining the climate system

To make it easier to carry out servicing on the climate system, drain the system first using the filling / draining valve. The unit is not fitted with a climate system drainage valve. This valve must be installed external from the product



NOTE

There may be some hot water when draining the heating medium side/climate system. There is a risk of scalding.

1. Connect a pipe to the system's external draining valve.
2. Then open the draining valve in order to drain the heating installation.

Circulation pump

Pump speed

The circulation pump in SHK 20-200 is controlled by frequency, and is automatically regulated via control and based on the heating / hot water demand.

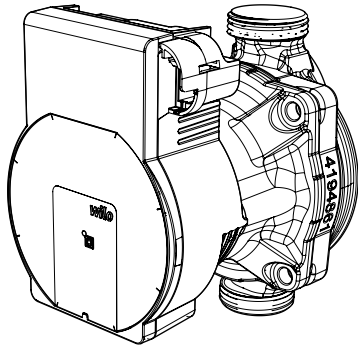

Available pressure, circulation pump GP12.

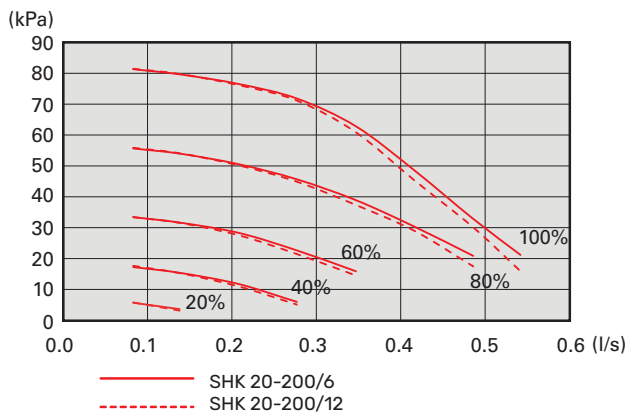

Post-adjustment, venting

Initially, air is released from the heating medium and venting may be necessary. If gurgling sounds can be heard from the climate system, the entire system will require additional venting. The system is vented via the vent valves. During venting, SHK 20-200 must be switched off.

Commissioning



NOTE

Commissioning of the system must be carried out by a person with appropriate authorizations and manufacturer's authorization!

For commissioning of the heat pump:

1. Switch on the power supply to SHK 20-200 making sure that the METROAIR L unit is properly connected to the power supply.
2. Follow the instructions displayed in the controller start guide.

Start Guide



NOTE

The climate system must be filled with water and vented before setting the switch to "I".

1. Set the switch (SF1) on the controller to "I".
2. Follow the instructions in the display's start guide. If the start guide does not start when you start the controller, start it manually in menu 5.7.



TIP

For more detailed information on the plant controls (operations, menus, etc.) refer to Chapter 8 Control - Introduction.

Commissioning

The first time the system is started up, a start guide is launched. The start guide instructions state what needs to be carried out at the first start-up together with a run through of the system's basic settings.

The start guide ensures that start-up is carried out correctly. The start guide can be started later in menu 5.7.

After running the start guide, the reversing valves are open in both directions to help vent the heat pump.



Caution

As long as the start guide is active, no function in the controller will start automatically. The guide will appear at each controller restart until it is disabled on the last page.



Caution

If starting up the system in low outdoor temperatures and a low heating medium temperature in the central heating system, the central heating system should be warmed up first, using the additional heat, to a temperature of about 20 - 25 °C.

Operating the start guide

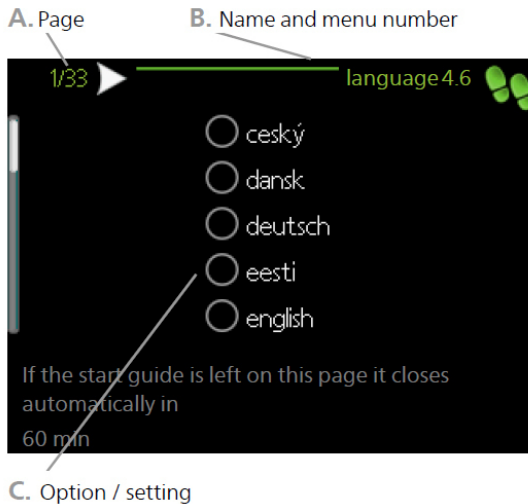

A. Page

Here you can see the menu level in the start guide. Scroll between the pages of the start guide as follows:

1. Turn the control knob until one of the arrows in the top left corner (at the page number) has been selected.
2. Press the OK button to skip between the pages in the start guide.

B. Name and menu number

Information about the menu page, to which the start guide refers, can be found in the control system. The digits refer to the menu number in the control system.

If you want to read more about a particular menu, either consult the help menu or read the user manual.

C. Option / setting

Enter settings for the system here.

D Help Menu



In many menus there is a symbol which indicates that extra help is available.

To view the help text:

1. Use the knob to select the help symbol.
2. Press the OK button.

The help text often consists of several windows that you can scroll between using the knob.

Commissioning without heat pump

The indoor unit can be used without a heat pump only as an electric boiler, to produce heat and hot water before the heat pump is installed, for example.

Go to menu 5.2 System settings and turn off the heat pump.



NOTE

Select the auto or manual operating mode when the indoor unit is to be used again with the heat pump.

Pressure relief valve

The pressure relief valve adjustment procedure applies to units with a flow meter installed. It should be carried out during system commissioning as follows:

1. Fully open the pressure relief valve.
2. Close the flow on all heating circuits downstream of the pressure relief valve.
3. Go to menu 5.6 Forced control and manually set the feed pump speed to 100%.
4. Go to menu 3.1.12.
5. At quarter turn intervals of one minute, close the pressure relief valve while checking the flow reading in menu 3.1.12. When the „Minimum flow during defrosting” value has been reached - see table in chapter 4, subchapter „Minimum flow in the system”, complete the valve closure.
6. You can then reopen the heating circuits and set the circulation pump to automatic mode in menu 5.6 Forced control.

8 Control - Introduction

Display unit

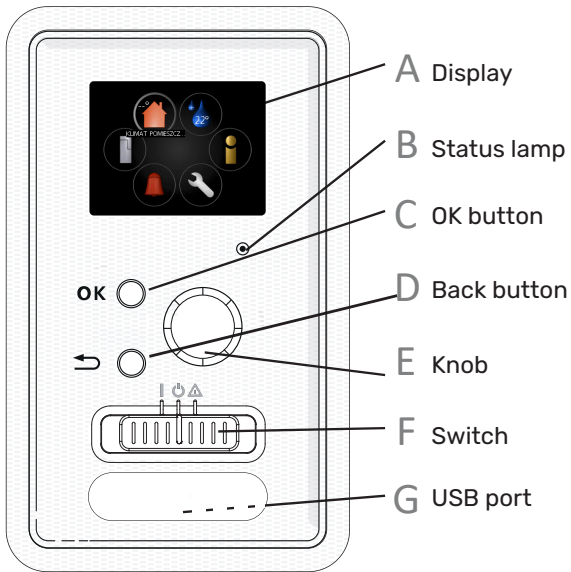

F Switch (SF1)

The switch offers three positions:

- On (I)
- Standby (⏻)
- Emergency mode (⚠)

Emergency mode must only be used in the event of a fault on the control module. In this mode, the compressor in the heat pump switches off and the immersion heater engages. The control module display is not illuminated and the status lamp illuminates yellow.

G USB port

The USB port is hidden beneath the plastic badge with the product name on it.

The USB port is used to update the software.

A Display

Instructions, settings and operational information are shown on the display. You can easily navigate between the different menus and options to set the comfort or obtain the information you require.

B Status lamp

The status lamp indicates the status of the control module. It:

- lights green during normal operation.
- lights yellow in emergency mode.
- lights red in the event of a deployed alarm.

C OK button

- The OK button is used to:
- confirm selections of sub menus/options/set values/page in the start guide.

D Back button

The back button is used to:

- go back to the previous menu.
- change a setting that has not been confirmed.

E Knob

The knob can be turned to the right or left.

You can:

- scroll in menus and between options.
- increase and decrease the values.
- change page in multiple page instructions (for example help text and service info).

Menu system

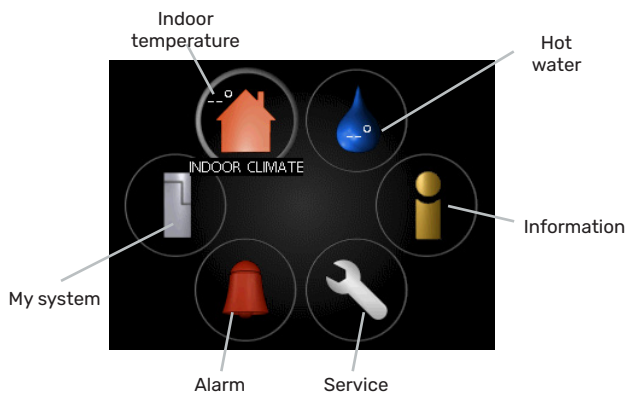

Menu 1 - INDOOR CLIMATE

Setting and scheduling the indoor climate. See information in the help menu or user manual in chapter MENU 1.

Menu 2 - HOT WATER

Setting and scheduling hot water production. See information in the help menu or user manual in chapter MENU 2.

Menu 3 - INFO

Display of temperature and other operating information and access to the alarm log. See information in the help menu or user manual in chapter MENU 3.

Menu 4 - MY SYSTEM

Setting time, date, language, display, operating mode etc. See information in the help menu or user manual in chapter MENU 4.

Menu 5 - SERVICE

Advanced settings. These settings are not available to the end user. The menu is visible when the Back button is pressed for 7 seconds, when you are in the start menu in chapter MENU 5.

Symbols in the display

The following symbols can appear in the display during operation.

Symbol	Description
	This symbol appears by the information sign if there is information in menu 3.1 that you should note.
	These two symbols indicate whether the compressor in the outdoor unit or additional heat in the installation is blocked via controller. These can, for example, be blocked depending on which operating mode is selected in menu 4.2, if blocking is scheduled in menu 4.9.5 or if an alarm has occurred that blocks one of them. Blocking the compressor Blocking additional heat
	This symbol appears if periodic increase or lux mode for the hot water is activated.
	This symbol indicates whether „holiday setting“ is active in 4.7.
	This symbol indicates whether the controller has contact with MyUplink.
	This symbol indicates the actual fan speed if these revolutions have been changed in relation to the normal setting. Required additional equipment ERS.
	This symbol indicates whether solar heating is active. Required additional equipment EME.
	This symbol indicates whether pool heating is active. Required additional equipment POOL 40.
	This symbol indicates whether cooling is active.

OPERATION

To move the check mark, turn the control knob to the left or the right. The marked position is white and/or has a turned up tab.



SELECTING MENU

To advance in the menu system select a main menu by marking it and then pressing the OK button. A new window then opens with sub menus.

Select one of the sub menus by marking it and then pressing the OK button.

SELECTING OPTIONS

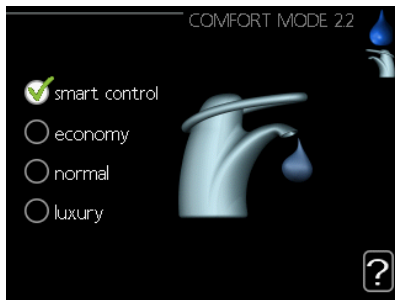

In an options menu the current selected option is indicated by a green tick.

To select another option:

1. Mark the applicable option. One of the options is pre-selected (white).
2. Press the OK button to confirm the selected option. The selected option has a green tick.







Setting a value



Values to be changed

To set a value:

1. Mark the value you want to set using the control knob. 
2. Press the OK button. The background of the value becomes green, which means that you have accessed the setting mode. 
3. Turn the control knob to the right to increase the value and to the left to reduce the value. 
4. Press the OK button to confirm the value you have set. To change and return to the original value, press the Back button. 

Use the virtual keyboard

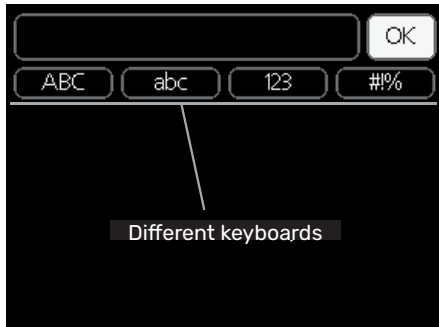

In some menus where text may require entering, a virtual keyboard is available.



Depending on the menu, you can gain access to different character sets which you can select using the control knob. To change character table, press the Back button. If a menu only has one character set the keyboard is displayed directly. When you have finished writing, mark „OK” and press the OK button.

Scroll through the windows

A menu can consist of several windows. Turn the control knob to scroll between the windows.

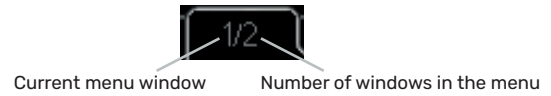

Scroll through the windows in the start guide



Arrows to scroll through window in start guide

1. Turn the control knob until one of the arrows in the top left corner (at the page number) has been marked.
2. Press the OK button to skip between the steps in the start guide.

Help menu



In many menus there is a symbol that indicates that extra help is available.

To access the help text:

Use the control knob to select the help symbol.

Press the OK button.

The help text often consists of several windows that you can scroll between using the knob.

9 Control

Menu 1 - INDOOR CLIMATE

1-INDOOR CLIMATE	1.1 temperature	1.1.1 - heating	
		1.1.2 - cooling	
	1.2 - ventilation ¹		
	1.3 - scheduling	1.3.1 - heating	
		1.3.2 - cooling	
		1.3.3 - ventilation ¹	
	1.9 - advanced	1.9.1 - curve	1.9.1.1 - heating curve
			1.9.1.2 - cooling curve
		1.9.2 - external adjustment	
		1.9.3 - min. flow line temp.	1.9.3.1 - heating
			1.9.3.2 - cooling
		1.9.4 - room sensor settings	
		1.9.5 - cooling settings	
		1.9.6 - fan return time ¹	
		1.9.7 - own curve	1.9.7.1 - heating
		1.9.7.2 - cooling	
	1.9.8 - point offset		

¹ The ERS additional equipment is necessary.

Menu 2 - HOT WATER

2 - HOT WATER	2.1 - temporary lux	
	2.2 - comfort mode	
	2.3 - scheduling	
	2.9 - advanced	2.9.1 - periodic increase
		2.9.2 - hot water recirc. ²

Menu 3 - INFO

3 - INFO	3.1 - service info
	3.2 - compressor info
	3.3 - add. heat info
	3.4 - alarm log
	3.5 - indoor temp. log

² The AXC 30 additional equipment is necessary.

Menu 4 - MY SYSTEM

4 - MY SYSTEM	4.1 - plus functions	4.1.1 - pool ³	
		4.1.2 - pool 2 ³	
		4.1.3 - internet	4.1.3.1 - MyUplink
			4.1.3.8 - tcp/ip settings
			4.1.3.9 - proxy settings
	4.2 - op. mode		
	4.3 - my icons		
	4.4 - time & date		
	4.6 - language		
	4.7 - holiday setting		
	4.9 - advanced	4.9.1 - op. prioritisation	
		4.9.2 - auto mode setting	
		4.9.3 - degree minute setting	
		4.9.4 - factory setting user	
		4.9.5 - schedule blocking	
	4.9.6 - schedule silent mode		

³ The POOL 40 additional equipment is necessary.

Menu 5 - SERVICE

5 - SERVICE	5.1 - operating settings	5.1.1 - hot water settings ⁶	
		5.1.2 - max flow line temperature	
		5.1.3 - max diff flow line temp.	
		5.1.4 - alarm actions	
		5.1.5 - fan sp. exhaust air ⁷	
		5.1.6 - fan sp. supply air ⁷	
		5.1.12 - addition	
		5.1.14 - flow set. climate system	
		5.1.22 - heat pump testing	
		5.1.23 - compressor curve	
		5.1.25 - time filter alarm	
	5.2 - system settings	5.2.2 - installed slaves	
		5.2.3 - docking	
		5.2.4 - accessories	
	5.3 - accessory settings	5.3.3 - extra climate system ⁸	
		5.3.4 - solar heating ⁹	
		5.3.6 - step controlled add. heat	
		5.3.8 - hot water comfort ⁶	
		5.3.11 - modbus ¹⁰	
		5.3.12 - exhaust/supply air module ⁷	
		5.3.14 - F135 ¹¹	
		5.3.15 - GBM communications module ¹²	
		5.3.16 - humidity sensor ¹³	
		5.3.21 - flow sensor / energy meter ¹⁴	
	5.4 - soft in/outputs		
	5.5 - factory setting service		
	5.6 - forced control		
	5.7 - start guide		
	5.8 - quick start		
	5.9 - floor drying function		
	5.10 - change log		
	5.11 - slave settings	5.11.1 - EB101	5.11.1.1 - heat pump
			5.11.1.2 - charge pump (GP12)
	5.12 - country		

⁶ The AXC 30 additional equipment is necessary.

⁷ The ERS additional equipment is necessary.

⁸ The ECS additional equipment is necessary.

⁹ The SOLAR 42 additional equipment is necessary.

¹⁰ The MODBUS additional equipment is necessary.

¹¹ The F135 additional equipment is necessary.

¹² The OPT additional equipment is necessary.

¹³ The HTS 40 additional equipment is necessary.

¹⁴ The EMK 300 additional equipment is necessary.

Start guide

The start guide appears when you first start the SHK 20-200. You can also enable the start guide in menu 5.7. The individual settings for the start guide factory settings are described below.

1/17 Language

In this menu, select the operating language of the controller.
Factory setting: english

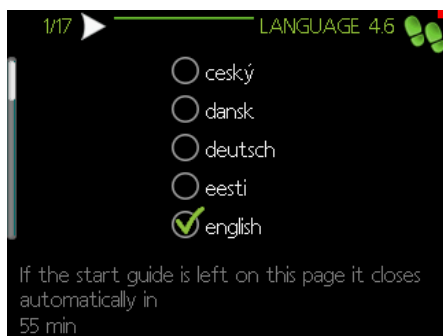

2/17 Information

This menu displays information about the start guide.

3/17 Country

Select where the product is to be installed here.

4/17 Flow. set. climate sys.

In this menu there is possibility to change settings for the essential settings of the heating system. More information after selecting „?”.

Factory setting: presetsings
Factory setting: radiator
Factory setting: -20.0 DOT C

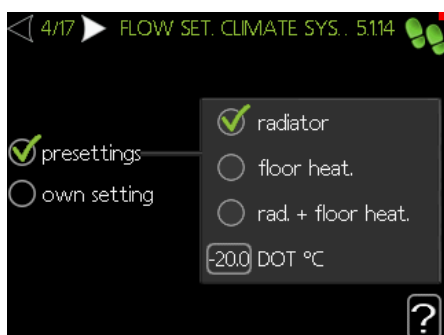

5/17 Accessories

In this menu it is possible to activate additional connected accessories. More information after selecting „?”.

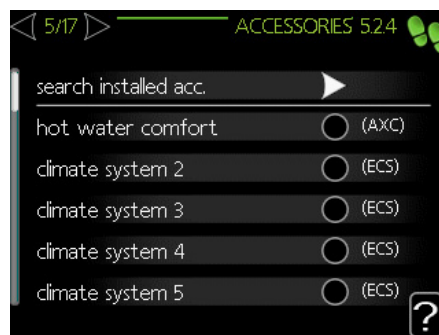

6/17 Room sensor settings

In this menu you can activate and change settings for the room sensor. More information after selecting „?”.

Factory setting: inactive

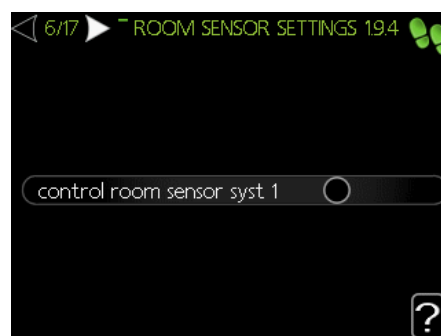

7/18 Control of external sensors

In this menu we have the possibility to check the allowed values for external sensors. More information after selecting „?”.

8/17 Internal electrical ad

In this menu we have the option to change settings for the additional heat (built-in electric additional heat). More information after selecting „?”.

Factory setting:
3x400 V incoming power: inactive (for 3 phases)
set max electrical add.: 4,5 kW
fuse size: 20A
transformation ratio: 300



NOTE

In the case of a fuse rating with a smaller value (applies to the main fuse rating in the house) you can set this value lower than 20 A. Note, this will reduce the power of the appliance. Connecting current sensors is required.

You cannot set this value higher than 20A.

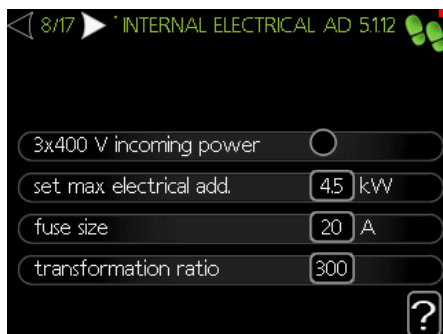

9/17 Installed slaves

In this menu, it is possible to select slave devices. More information after selecting „?”.

Factory setting:
slave 1: active (EB101)



NOTE

The SHK 20-200 unit cannot be cascaded with heat pumps.

10/17 Time & date

In this menu, set the current date and time. In addition, we have the ability to choose the display format and time zone.

11/17 Min. flow line temp.

In this menu it is possible to edit the minimum flow temperature of the heating system. More information after selecting „?”.

Factory setting:
climate system 1: 20 C

12/17 Max flow line temp.

In this menu it is possible to edit the maximum flow temperature of the heating system. More information after selecting „?”.

Factory setting:
climate system 1: 55 C

Recommended setting values are:

- + 35 for surface heating,
- + 55 for radiator heating.

13/17 Heating curve

In this menu it is possible to edit the heating curve specified for the SHK 20-200 unit. More information after selecting „?”.

Factory setting:
Heating curve: 7

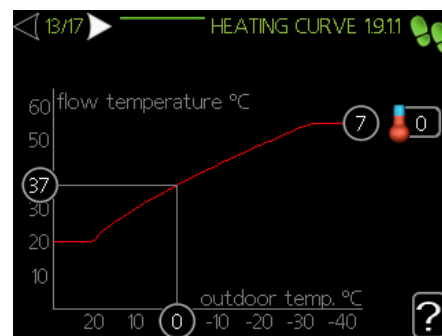

Detailed information on curve settings - see pt. „User settings”.

Settings for the user

14/17 Op. mode

In this menu, you can select the operating mode for the SHK 20-200 unit. More information after selecting „?”.

Factory setting: auto

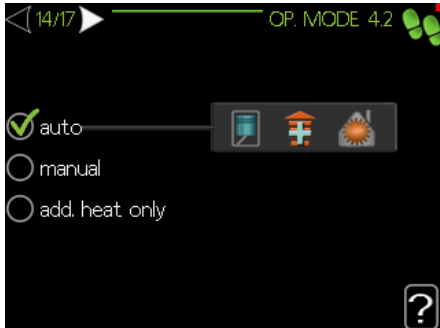

Caution

Recommended „auto” operating mode. Editing is only possible by qualified personnel.

15/17 Alarm actions

In this menu it is possible to activate alarm actions. More information after selecting „?”.

Factory setting:

decrease room temp: inactive

deactivate hot water: inactive

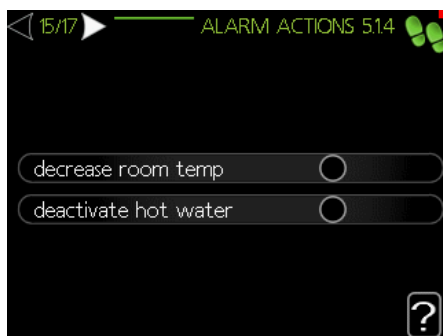

16/17 Reminder

Reminder to complete the checklist in the first chapter of the user manual.

17/17 Start guide

In this menu, we can decide whether the start guide will run again the next time the system is started.

Menu 1 - Indoor climate

The menu INDOOR CLIMATE is used to correct the settings for the heating system.

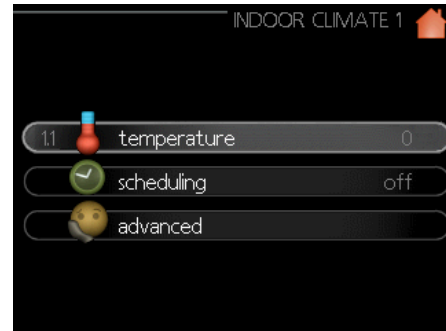

Menu 1.1 - Temperature

In this menu, you can set the temperature for the climate system. The status information shows the set point values for the climate system.

In Menu 1.1 choose between heating or cooling (if active) and then set the desired temperature in the next menu "Heating/cooling temperature".

The display shows the set point values for the system (offset heating curve). To increase or reduce the indoor temperature, increase or reduce the value on the display.

For more information select „?”.

Setting the temperature (without room sensors activated):
Setting range: -10 do +10

Factory setting: 0

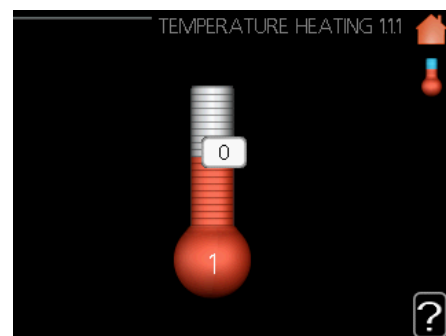

Menu 1.3 - scheduling

In the menu scheduling indoor climate (heating/cooling/ventilation) is scheduled for each weekday. You can also schedule a longer period during a selected period (vacation) in menu 4.7.

In menu 1.3, select heating or cooling (if active), then program the room temperature increase or decrease for up to three time intervals throughout the day. More information after selecting „?”.

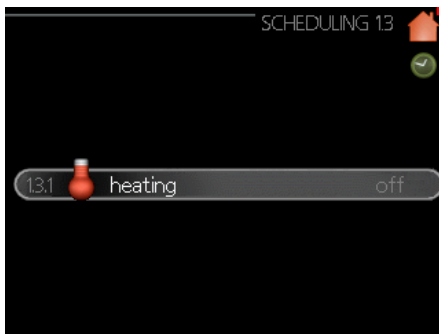

Factory setting:
heating: off
cooling (if activated): off

Activated: Scheduling for the selected period is activated here. Set times are not affected at deactivation.

System: Which climate system the schedule is for is selected here. This alternative is only displayed if more than one climate system is present.

Day: Select which day or days of the week the schedule is to apply to here. To remove the scheduling for a particular day, the time for that day must be reset by setting the start time to the same as the stop time. If the line „all” is used, all days in the period are set for these times.

Time period: The start and stop time for the selected day for scheduling are selected here.

Adjustment: See relevant sub menu.

Conflict: If two settings conflict with each other a red exclamation mark is displayed.

Menu 1.9 - Advanced

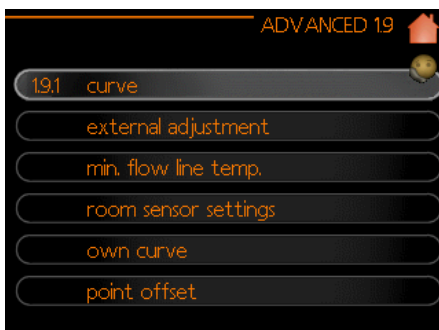

This menu is intended for advanced users. This menu has several sub-menus.

Menu 1.9.1 - curves

You can select heating or cooling (if active) in the curve menu. The next menu (heating curve/cooling curve) shows the heating and cooling curves for your house. The task of the curve is to give an even indoor temperature, regardless of the outdoor temperature, and thereby energy efficient operation. It is from these heat curves that the heat pump's control computer determines the temperature of the water to the system, the supply temperature, and therefore the indoor temperature. Select the curve and read off how the supply temperature changes at different outdoor temperatures here. The number to the far right of „system” displays which system you have selected the heating curve/cooling curve for.

The optimum slope depends on the climate conditions in your location, if the house has radiators or under floor heating and how well insulated the house is.

The curve is set when the heating installation is installed, but may need adjusting later. Normally, the curve will not need further adjustment. More information after selecting „?”.

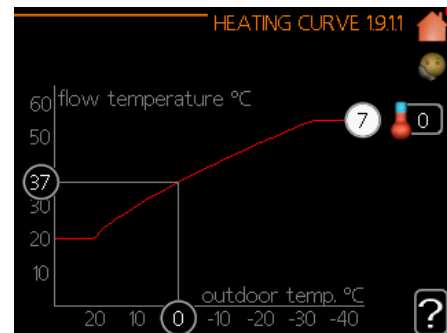

Factory setting:
Heating curve: 7



Caution

When making fine adjustments of the indoor temperature, the curve must be offset up or down instead, this is done in menu 1.1 temperature.



NOTE

Under floor heating systems are normally max flow line temperature set to between 35 and 45 °C. Must be restricted with underfloor cooling min. flow line temp. to prevent condensation. Check the max temperature for your floor with your installer/floor supplier.

The figure at the end of the curve indicates the curve slope. The figure beside the thermometer gives the curve offset. Use the control knob to set a new value. Confirm the new setting by pressing the OK button.

Curve 0 is an own curve created in menu 1.9.7.



TIP

Wait 24 hours before making a new setting, so that the room temperature has time to stabilise.

If it is cold outdoors and the room temperature is too low, increase the curve slope by one increment.

If it is cold outdoors and the room temperature is too high, lower the curve slope by one increment.

If it is warm outdoors and the room temperature is too low, increase the curve offset by one increment.

If it is warm outdoors and the room temperature is too high, lower the curve offset by one increment.

Menu 1.9.2 - external adjustment

Connecting an external contact, for example, a room thermostat or a timer allows you to temporarily or periodically raise or lower the room temperature while heating. When the contact is on, the heating curve offset is changed by the number of steps selected in the menu. If a room sensor is installed and activated the desired room temperature (°C) is set. If there is more than one climate system the setting can be made separately for each system. More information after selecting „?”.

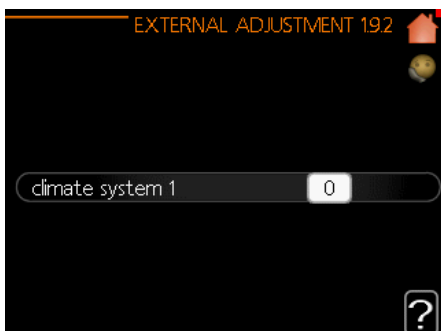

Factory setting:
heating
climate system 1: 0

cooling (if activated)
climate system 1: 0

Menu 1.9.3 - min. flow line temp.

In menu 1.9.3 you select heating or cooling (if active), in the next menu (min. supply temp.heating/cooling) set the minimum temperature on the supply temperature to the climate system. This means that SHK 20-200 never calculates a temperature lower than that set here.

If there is more than one climate system the setting can be made separately for each system.

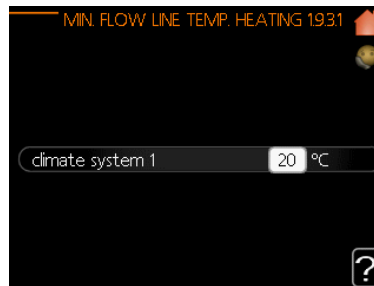

Factory setting:
heating
climate system 1: 20

cooling (if activated)
climate system 1: 18



NOTE

In the case of active cooling, the minimum temperature must be set based on the cooling temperature.



TIP

The value can be increased if you have, for example, a cellar that you always want to heat, even in summer.

You may also need to increase the value in „stop heating” menu 4.9.2 „auto mode setting”.

Menu 1.9.4 - room sensor settings

Here you can turn on room sensors that regulate the room temperature.



Caution

A slow heat-releasing heating system, such as for example, underfloor heating, may not be suitable for control using the heat pump’s room sensor.

Here you can set a factor (a numerical value) that determines how much an over or sub normal temperature (the difference between the desired and actual room temperature) in the room is to affect the supply temperature to the climate system. A higher value gives a greater and faster change of the heating curve’s set offset. More information after selecting „?”.



NOTE

Too high a set value for „factor system” can (depending on your climate system) produce an unstable room temperature.

Factory setting: inactive

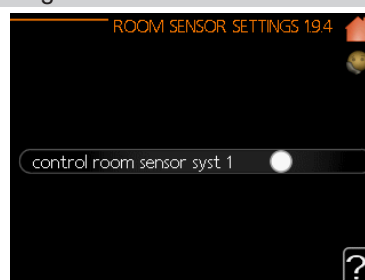

Menu 1.9.5 - cooling settings (if active)

You can use SHK 20-200 to cool the house during hot periods of the year. More information after selecting „?”.

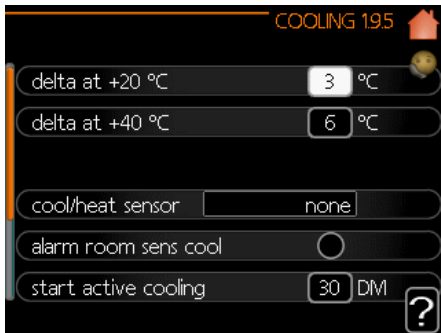

heat/cool sensor

An additional temperature sensor can be connected to the heat pump to determine when to switch between heating and cooling.

When several heating/cooling sensors are installed, you can select which one of them should be in control.



Caution
When the heating/cooling sensors BT74 have been connected and activated in menu 5.4, no other sensor can be selected in menu 1.9.5.

start active cooling

Here you can set when active cooling is to start. Degree minutes are a measurement of the current heating/cooling demand in the house and determine when the compressor, cooling operation respectively additional heat will start/stop.

Factory settings:
Delta at +20 C.: 3 °C
Delta at +40 C.: 6 °C

Heat./cool. sensor: N/A
Alarm - room sens. cooling: deactivated
Start active cooling 30 DM
Time betw. switch heat/cool: 2 hours

Menu 1.9.7 - own curve

In this menu user can create own heating or cooling (if active) curve, by setting the desired supply temperatures for different outdoor temperatures.



Caution
Curve 0 in menu 1.9.1 must be selected for own curve to apply.



Caution
The own curve can only be edited by qualified personnel.

Menu 1.9.8 - point offset

Make the correction for the heating curve at a certain outdoor temperature here.

One step is usually enough to change the room temperature one degree, but in some cases several steps may be required.

The heating curve changes its slope within ± 5 °C from the outdoor temperature point for which the point shift was entered.

It is important to select the correct heating curve to ensure a constant room temperature.

More information after selecting „?”.

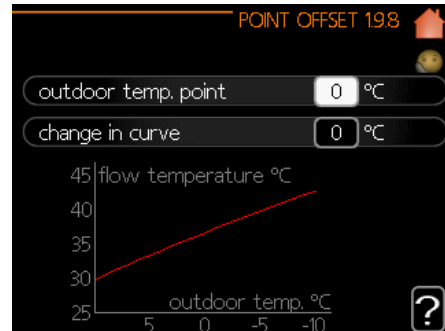

Caution
The point offset can only be edited by qualified personnel.

Menu 2 - HOT WATER

The Hot water menu is used to adjust the settings for domestic hot water. The user has the option of editing temperatures and operating modes for hot water. For the menu HOT WATER there are several sub-menus. Status information for the relevant menu can be found on the display to the right of the menus.

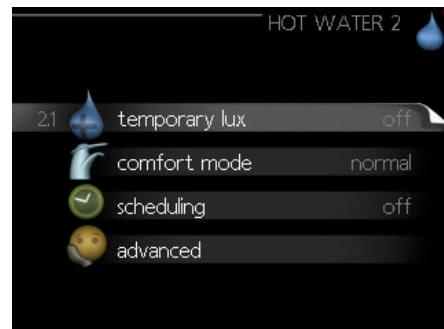

Menu 2.1 - temporary lux

Activation of temporary increase in hot water temperature. Status information gives „off” or duration of temporary increase in temperature increase. More information after selecting „?”.

Factory setting: off

When hot water requirement has temporarily increased this menu can be used to select an increase in the hot water temperature to lux mode for a selectable time.

Caution

If comfort mode „luxury” is selected in menu 2.2 no further increase can be carried out.

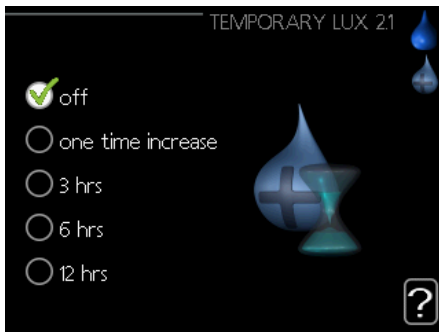

The function is activated immediately when a time period is selected and confirmed using the OK button. The remaining time for the selected setting is shown to the right. When the time has run out controller returns to the mode set in menu 2.2.

Select "off" to switch off temporary lux..

Menu 2.2 - comfort mode

In this menu, we have the choice of operating modes for different hot water temperatures. More information after selecting „?”.

Factory setting: normal

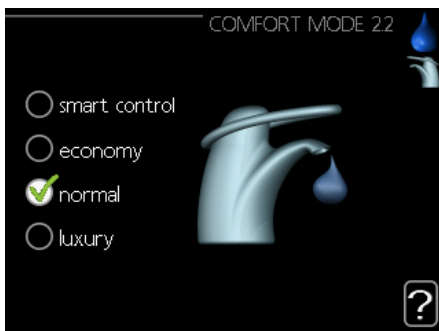

smart control - The Smart control function is activated in this menu. This function remembers the hot water consumption in the previous week and adjusts the temperature in the hot water heater for the upcoming week to ensure minimal energy consumption.

After activating the Intelligent Steering function, the heater has a hot water heater offers the performance given on the energy label.

economy - This mode gives less hot water than the others, but is more economical. This mode can be used in smaller households with a small hot water requirement.

normal - Normal mode gives a larger amount of hot water and is suitable for most households.

luxury - Lux mode gives the greatest possible amount of hot water. In this mode the immersion heater may be partially used to heat hot water, which may increase operating costs.

Menu 2.3 - scheduling

Here you can program the hot water temperature. for two different time intervals throughout the day. Scheduling is activated/deactivated by ticking/unticking "activated". Set times are not affected at deactivation. More information after selecting „?”.

Factory setting: off

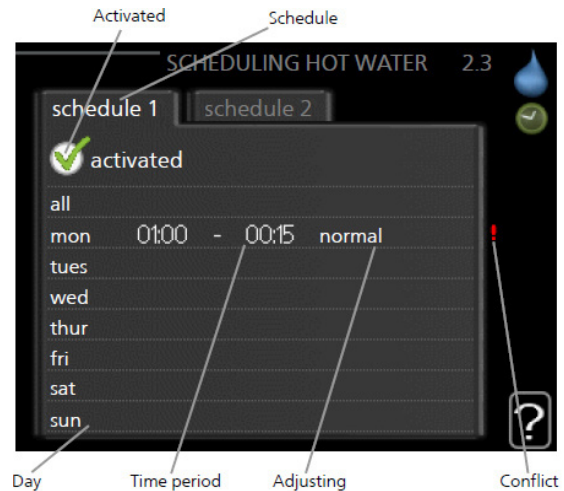

Schedule: The schedule to be changed is selected here.

Activated: Scheduling for the selected period is activated here. Set times are not affected at deactivation.

Day: Select which day or days of the week the schedule is to apply to here. To remove the scheduling for a particular day, the time for that day must be reset by setting the start time to the same as the stop time. If the line „all” is used, all days in the period are set for these times.

Time period: The start and stop time for the selected day for scheduling are selected here.

Adjusting: Set the hot water comfort that is to apply during scheduling here.

Conflict: If two settings conflict with each other a red exclamation mark is displayed.



TIP

If you wish to set similar scheduling for every day of the week start by filling in "all" and then changing the desired days.

Menu 2.9 - Advanced

The advanced menu is intended for advanced users only.

Menu 2.9.1 - periodic increase

To prevent bacterial growth in the water heater, the compressor and the immersion heater can increase the hot water temperature for a short time at regular intervals. More information after selecting „?”.

The length of time between increases can be selected here. The time can be set between 1 and 90 days. Factory setting is 7 days. Tick/untick „activated” to start/switch off the function.

Factory setting:
activated: on
period: 7 days
start time: 00:00



Menu 3 - INFO

The information menu is used to read information. The status information of the menu is displayed to the right of the menu.

Menu 3.1 - service info

Information about the heat pump's actual operating status (e.g. current temperatures etc.) can be obtained here. No changes can be made. The information is on several pages. Turn the control knob to scroll between the pages. A QR code appears on one side. This QR code indicates serial number, product name and limited operating data.

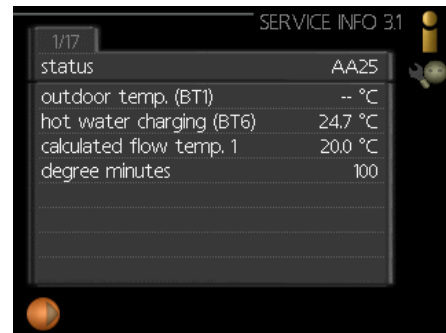

Menu 3.2 - compressor info

Information about the compressor's operating status and statistics can be obtained here. No changes can be made. The information is on several pages. Turn the control knob to scroll between the pages. More information after selecting „?”.

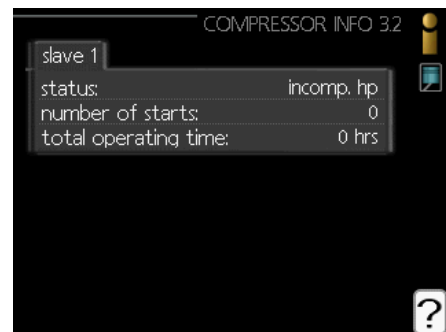

Menu 3.3 - Add. heat info

Information about the additional heat's settings, operating status and statistics can be obtained here. No changes can be made. The information is on several pages. Turn the control knob to scroll between the pages. More information after selecting „?”.

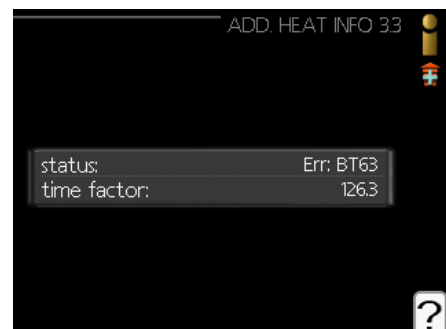

Menu 3.4 - alarm log

To facilitate fault-finding the heat pump operating status at alarm alerts is stored here. You can see information for the 10 most recent alarms. To view the run status in the event of an alarm, mark the alarm and press the OK button.

Date	Time	Description
18.06.2019	01:22	incomp. hp
18.06.2019	01:21	Comm.
18.06.2019	01:21	Err: BT63
18.06.2019	01:21	Err: EQ1-BT64
18.06.2019	01:21	Sensor ftt:BT1
18.06.2019	01:20	starts
17.06.2019	02:27	incomp. hp
17.06.2019	02:26	Comm.
17.06.2019	02:26	Err: BT63
17.06.2019	02:26	Err: EQ1-BT64

Menu 3.5 - indoor temp. log

Here you can see the average temperature indoors week by week during the past year. The dotted line indicates the annual average temperature.

The average outdoor temperature is only shown if a room temperature sensor/room unit is installed.

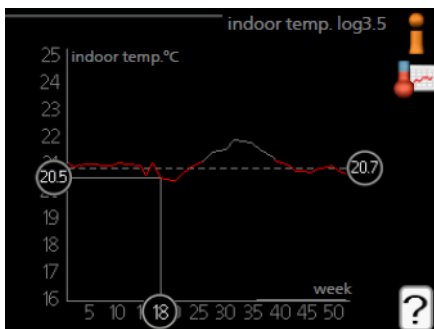

To read off an average temperature

1. Turn the control knob so that the ring on the shaft with the week number is marked.
2. Press the OK button.
3. Follow the grey line up to the graph and out to the left to read off the average indoor temperature at the selected week.
4. You can now select to take read outs for different weeks by turning the control knob to the right or left and read off the average temperature.
5. Press the OK or Back button to exit read off mode.

Menu 4 - MY SYSTEM

This menu contains information about the work and driver settings. Status information for the relevant menu can be found on the display to the right of the menus.

Menu 4.1 - plus functions

Settings for any additional functions installed in SHK 20-200 can be made in the sub menus.

Menu 4.1.3 - internet

Here you make settings for connecting SHK 20-200 to the internet. More information after selecting "?".

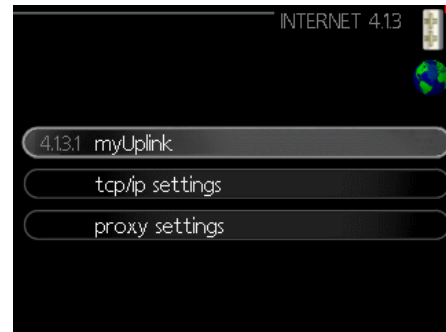

NOTE

For these functions to work the network cable must be connected.

Menu 4.2 - op. mode

The heat pump operating mode is usually set to „auto“. It is also possible to set the heat pump to „add. heat only“, but only when an addition is used, or „manual“ and select yourself what functions are to be permitted.

Change the operating mode by marking the desired mode and pressing the OK button. When an operating mode is selected, it shows what is permitted in the heat pump (crossed out = not permitted) and selectable alternatives to the right. To select selectable functions that are permitted or not, mark the function using the control knob and press the OK button. More information after selecting "?".

Factory setting: auto

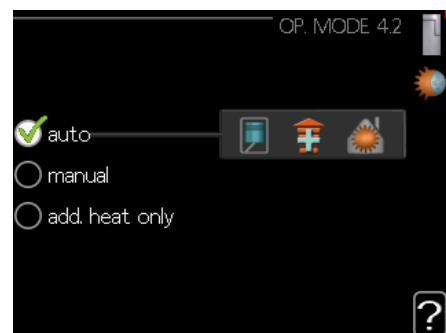

Operating mode auto

In this operating mode the heat pump automatically selects what functions are permitted.

Operating mode manual

In this operating mode you can select what functions are permitted. You cannot deselect „compressor“ in manual mode.

Operating mode add. heat only

In this operating mode the compressor is not active, only additional heat is used.



NOTE

If you choose mode „add. heat only” the compressor is deselected and there is a higher operating cost.

Menu 4.4 - time & date

Set time and date, display mode and time zone here.

Menu 4.6 - language

Choose the language that you want language 4.6 the information to be displayed in here.

Menu 4.7 - holiday setting

To reduce energy consumption during a holiday you can schedule a reduction in heating and hot water temperature. Cooling, ventilation and pool can also be scheduled if the functions are connected.

If a room sensor is installed and activated, the desired room temperature (°C) is set during the time period. This setting applies to all climate systems with room sensors.

If a room sensor is not activated, the desired offset of the heating curve is set. One step is usually enough to change the room temperature by one degree, but in some cases several steps may be required. This setting applies to all climate systems without room sensors.

Vacation scheduling starts at 00:00 on the start date and stops at 23:59 on the stop date.

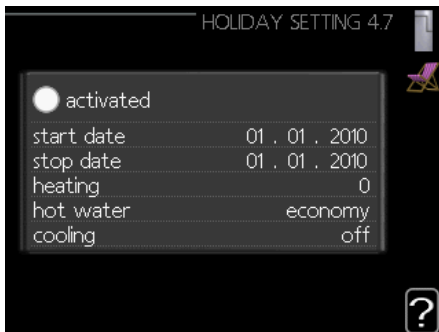

Caution

If you choose to switch off hot water production during the vacation “periodic increase” (preventing bacterial growth) are blocked during this time. „periodic increase” started in conjunction with the vacation setting being completed.

Menu 4.9 - advanced

In this menu, we configure advanced functions of the SHK 20-200 controller. More information after selecting „?”.

Menu 4.9.1 - op. prioritisation

Choose here how long the heat pump should work with each requirement if there are two or more requirements at the same time. If there is only one requirement the heat pump only works with that requirement.

The indicator marks where in the cycle the heat pump is. If 0 minutes is selected it means that requirement is not prioritised, but will only be activated when there is no other requirement. More information after selecting „?”.

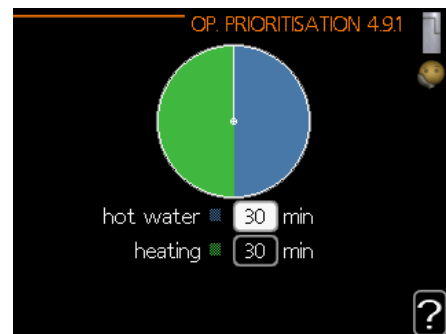

Menu 4.9.2 - auto mode setting

When the operating mode is set to „auto”, the heat pump selects when start and stop of additional heat and heat production is permitted, dependent on the average outdoor temperature.

In this menu you set the average outdoor temperatures, the time (filtering time) during which the average temperature is calculated. You can also set the cooling start temperature (if activated).

More information after selecting „?”.

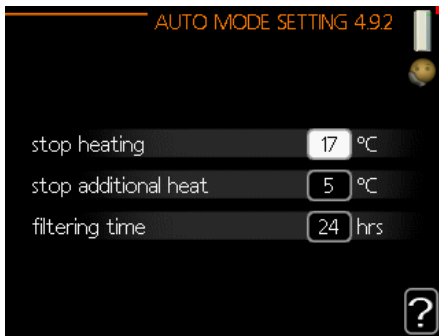

Factory settings:
 Stop heating: 17°C
 Stop add. heat: 5°C
 Filtering time: 24 hrs

Caution
 It cannot be set „stop additional heat” higher than „stop heating”.

Caution
 In systems where heating and cooling share the same pipes „stop heating” cannot be set higher than „start cooling” if there is not a cooling/ heating sensor.

Menu 4.9.3 - degree minute setting

Degree minutes are a measurement of the current heating requirement in the house and determine when the compressor respectively additional heat will start/stop. More information after selecting „?”.

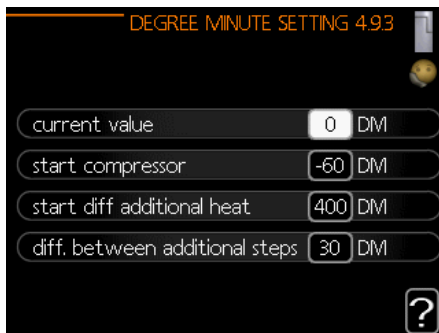

Factory setting:
 current value 0 DM
 start compressor: -60 DM
 start diff additional heat: 400 DM
 diff. between additional steps: 30 DM

Caution
 Higher value on „start compressor” gives more compressor starts, which increase wear on the compressor. Too low value can give uneven indoor temperatures.

Menu 4.9.4 -factory setting user

All settings that are available to the user (including advanced menus) can be reset to default values here. More information after selecting „?”.



Caution
 After applying a factory reset of the appliance, all individual settings (such as heating curve etc.) will be deleted.

Menu 4.9.5 - schedule blocking

The compressor can be scheduled to be blocked for up to two different time periods here. When scheduling is active the actual blocking symbol in the main menu on the heat pump symbol is displayed. More information after selecting „?”.

TIP
 If you wish to set similar scheduling for every day of the week start by filling in “all” and then changing the desired days.

TIP
 Set the stop time earlier than the start time so that the period extends beyond midnight. Scheduling then stops at the set stop time the day after.

Scheduling always starts on the date that the start time is set for.

Caution
 Long term blocking can cause reduced comfort and operating economy.

Submenu SERVICE

Go to the main menu and hold the Back button in for 7 seconds to access the Service menu.

Menu SERVICE has orange text and is intended for the advanced user. This menu has several sub-menus. Status information for the relevant menu can be found on the display to the right of the menus

- operating settings Operating settings for the control module.
- system settings System settings for the control module, activating accessories etc
- accessory settings Operational settings for different accessories.
- soft in/outputs Setting software controlled in and outputs on the input card (AA3) and terminal block (X2).
- factory setting service Total reset of all settings (including settings available to the user) to default values.
- forced control Forced control of the different components in the indoor module
- start guide Manual start of the start guide which is run the first time when the control module is started.
- quick start Quick starting the compressor.



NOTE

Incorrect settings in the service menus can damage the installation, heat pump and indoor unit.

Menu 5.1 - operating settings

Operating settings can be made for the control module in the sub menus.

Menu 5.1.1 - hot water settings

Operating settings can be made for the control module in the sub menus.

economy

Setting range start temp. economy: 5 – 50°C

Factory setting start temp. economy: 39°C

Setting range stop temp. economy: 5 – 50°C

Factory setting stop temp. economy: 43°C

normal

Setting range start temp. normal: 5 – 55°C

Factory setting start temp. normal: 42°C

Setting range stop temp. normal: 5 – 55°C

Factory setting stop temp. normal: 46°C

luxury

Setting range start temp. lux: 5 – 60°C

Factory setting start temp. lux: 45°C

Setting range stop temp. lux: 5 – 60°C

Factory setting stop temp. lux: 49°C

stop temp. per. increase

Setting range: 55 – 60°C

Factory setting: 60°C

step difference compressors

Setting range: 0,5 – 4,0 °C

Factory setting: 1,0°C

charge method

Setting range: target temp, delta temp

Factory setting: delta temp

Here you set the start and stop temperature of the hot water for the different comfort options in menu 2.2 as well as the stop temperature for periodic increase in menu 2.9.1.

Menu 5.1.2 - max flow line temperature

climate system

Setting range: 5-70°C

Factory setting: 55 °C

Set the maximum supply temperature for the climate system here. If the installation has more than one climate system, individual maximum supply temperatures can be set for each system. Climate systems 2 - 8 cannot be set to a higher max supply temperature than climate system 1.



Caution

Underfloor heating systems are normally max flow line temperature set between 35 and 45 °C.

In order to obtain information on the maximum permitted temperature, ask the floor supplier / contractor for floor heating and the heating system.

Menu 5.1.3 - max diff flow line temp.

max diff compressor

Setting range: 1 – 25 °C

Factory setting: 10 °C

max diff addition

Setting range: 1 – 24 °C

Factory setting: 7 °C

Here you set the maximum permitted difference between the calculated and actual supply temperature during compressor respectively add. heat mode. Max diff. additional heat can never exceed max diff. compressor

max diff compressor

If the current supply temperature exceeds the calculated flow with set value, the degree minute value is set to 0. The compressor in the heat pump stops when there is only a heating demand.

max diff addition

If „addition“ is selected and activated in menu 4.2 and the present supply temp exceeds the calculated with set value, the additional heat is forced to stop.

Menu 5.1.4 - alarm actions

Select how you want the control module to alert you that there is an alarm in the display here. The different alternatives are; the heat pump stops producing hot water and/or reduces the room temperature.

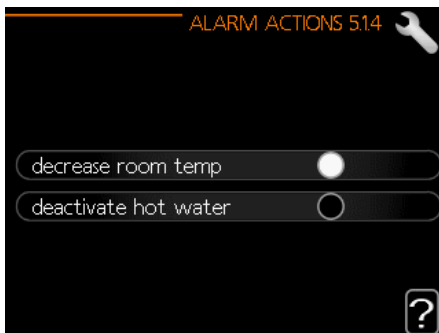

Caution

If no alarm action is selected, it can result in higher energy consumption in the event of an alarm.

Menu 5.1.5 - Fan sp. exhaust air



NOTE

Menu 5.1.5 is inactive in the factory settings. For this menu function to be active, the ERS accessory must be installed and activated in the accessories menu. 5.2.4.

For detailed information on the accessory settings, refer to the respective accessory's manual.

normal and speed 1-4

Setting range: 0 – 100 %

Factory setting: normal: 75%

Factory setting: speed 1: 0%

Factory setting: speed 2: 30%

Factory setting: speed 3: 80%

Factory setting: speed 4: 100%

Set the speed for the five different selectable speeds for the fan here.



Caution

Incorrectly set ventilation flow can damage the building and can also increase energy consumption due to operation of the auxiliary heater.

Menu 5.1.6 - fan sp. supply air



NOTE

Menu 5.1.6 is inactive in the factory settings. For this menu function to be active, the ERS accessory must be installed and activated in the accessories menu. 5.2.4.

normal and speed 1-4

Setting range: 0 – 100 %

Factory setting: normal: 75%

Factory setting: speed 1: 0%

Factory setting: speed 2: 30%

Factory setting: speed 3: 80%

Factory setting: speed 4: 100%

Set the speed for the five different selectable speeds for the fan here.



Caution

An incorrectly set value may damage the house in the long term and possibly increase energy consumption.

Menu 5.1.12 - internal electrical addition

The settings in this menu apply to the method of controlling the auxiliary heater.

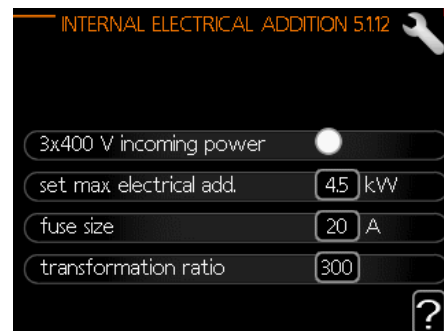

NOTE

The factory settings introduced in menu 5.1.12 are the required settings. Editing these settings is only possible by authorized installers and service technicians!

Factory setting:

3x400 V incoming power: inactive

set max electrical add.: 4,5 kW

fuze size: 20A

transformation ratio: 300



NOTE

Setting the fuse size too low may cause the peak source to malfunction and/or compressor power limitation.

Menu 5.1.14 - flow set. climate system

Factory setting: presets

Setting range: radiator, floor heat., rad. + floor heat., DOT °C

Default value: radiator

Setting range DOT: -40,0 – 20,0°C

The factory setting of DOT value depends on the country that has been given for the product's location. The example below refers to Poland.

Factory setting DOT: -20.0 °C

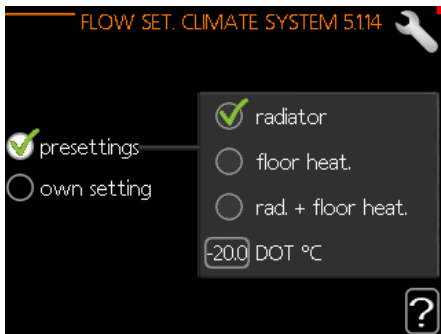

The type of heating distribution system the heating medium pump works towards is set here.

dT at DOT is the difference in degrees between flow and return temperatures at dimensioned outdoor temperature.

Menu 5.1.22 - heat pump testing

NOTE

This menu is intended for testing the controller according to different standards. Use of this menu for other reasons may result in your installation not functioning as intended.

This menu contains several sub-menus, one for each standard.

Menu 5.1.23 - compressor curve

Caution

The compressor curves can only be edited by qualified personnel.

NOTE

This menu is only displayed if the controller is connected to a heat pump with inverter controlled compressor.

Set whether the compressor in the heat pump should work to a particular curve under specific requirements or if it should work to predefined curves.

You set a curve for a demand (heat, hot water etc.) by un-ticking „auto“, turning the control knob until a temperature is marked and pressing OK. You can now set at what temperatures the max. and min. frequencies, respectively will occur.

This menu can consist of several windows (one for each available demand), use the navigation arrows in the top left corner to change between the windows.

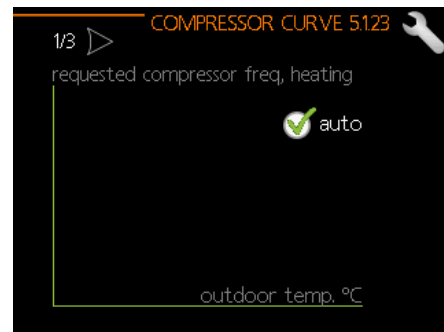

Menu 5.2 - system settings

Make different system settings for your installation here, e.g. activate connected slaves and which accessories are installed.

Menu 5.2.2 - installed slaves

The function is inactive by default - one device can be selected.

search installed slaves

Mark "search installed slaves" and press the OK button to automatically find connected slaves for the master heat pump.

Menu 5.2.4 - accessories

The additional equipment installed in the system is defined here (See Section „Accessories“).

Connected accessories can be started in two ways. You can select the options in the list or use the automatic function „search installed acc“.

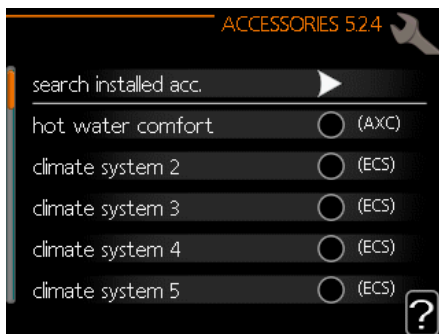

search installed acc.

Select „search installed acc“ and press OK to automatically search for connected accessories for the controller.

ACTIVATING 4 - PIPE COOLING OPERATION

In order to activate 4-pipe cooling, select the function "active cooling 4 pipe".

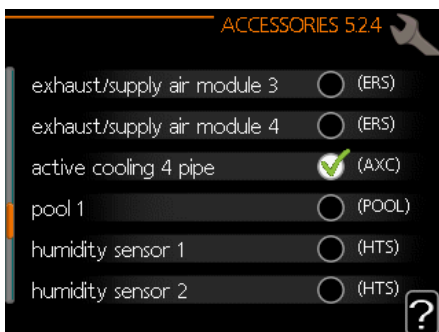

Menu 5.3 - accessory settings

The working settings of the installed and activated accessories are entered in the submenu.

! NOTE
Menu 5.3 is inactive in the factory settings. In order for this menu function to be active, it is necessary to install an additional accessory and activate it in the accessories menu. 5.2.4.

A detailed description of programming the accessories can be found in the instructions for the individual accessories.

Menu 5.3.3 - extra climate system

! NOTE
Menu 5.3.3 is inactive in the factory settings. For this menu function to be active, the ECS accessory must be installed and activated in the accessories menu. 5.2.4.

A detailed description of programming the accessories can be found in the instructions for the individual accessories.

Menu 5.3.6 - step controlled add. heat

! NOTE
Menu 5.3.6 is inactive in the factory settings. For this menu function to be active, you must install the AXC 30 accessory and activate it in the accessories menu. 5.2.4.

A detailed description of programming the accessories can be found in the instructions for the individual accessories.

Menu 5.3.11 - Modbus

NOTE
Menu 5.3.11 is inactive in the factory settings. In order for this menu function to be active, it is necessary to install the MODBUS 40 accessory and activate it in the accessories menu. 5.2.4.

A detailed description of programming the accessories can be found in the instructions for the individual accessories.

Menu 5.3.12 - exhaust/supply air module

NOTE
Menu 5.3.12 is inactive in the factory settings. For this menu function to be active, the ERS accessory must be installed and activated in the accessories menu. 5.2.4.

A detailed description of programming the accessories can be found in the instructions for the individual accessories.

Menu 5.3.14 - F135

NOTE
Menu 5.3.14 is inactive in the factory settings. For this menu function to be active, the F135 accessory must be installed and activated in the accessories menu 5.2.4.

A detailed description of programming the accessories can be found in the instructions for the individual accessories.

Menu 5.3.16 - humidity sensor

NOTE
Menu 5.3.16 is inactive in the factory settings. For this menu function to be active, you must install the HTS 40 accessory and activate it in the accessories menu. 5.2.4.

A detailed description of programming the accessories can be found in the instructions for the individual accessories.

Menu 5.3.21 - flow sensor / energy meter

NOTE
Menu 5.3.20 is inactive in the factory settings. For this menu function to be active, installation of the EMK accessory is required and its activation in the accessories menu 5.2.4.

A detailed description of programming the accessories can be found in the instructions for the individual accessories.

Menu 5.4 - soft in/outputs

In this menu, you can select which input on the input card (AA3) can be connected to an external signal (page 87). Available entries on terminal strips AUX1-3 (AA3-X6: 9-14). The AUX inputs are freely programmable and allow the introduction of additional functions using external signals.

NOTE
The signal for the AUX inputs must be a zero-voltage signal (make-break contact).

Input AA3-X7 can be programmed as required.

Factory setting:

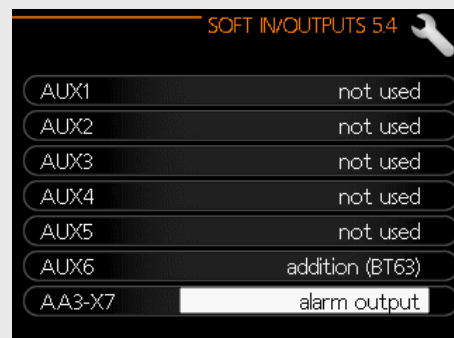

Possible configurations AA3-X7:

- Not used,
- Holiday,
- Away mode,
- Alarm output,
- Hot water recirculation,
- Ext heat. med. pump

Menu 5.5 - factory setting service

All settings can be reset (including settings available to the user) to default values here.

NOTE
When resetting, the start guide is displayed the next time the control module is restarted with factory settings.

Menu 5.6 - forced control

You can force control the different components in the control module and any connected accessories here.

This menu is used to test individual components of the SHK 20-200.

Menu 5.7 - start guide

The first time you start the SHK 20-200, the start guide starts automatically. In this menu we have the ability to run it manually. For more information about the start guide, see page 52.

Menu 5.8 - quick start

It is possible to start the compressor from here.

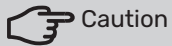

Caution
There must be a heating or hot water demand to start the compressor.



Caution
Do not quick start the compressor too many times over a short period of time as this may damage the compressor and its surrounding equipment.

Menu 5.9 - floor drying function

length of period 1 – 7

Setting range: 0 – 30 days

Factory setting, period 1 – 3, 5 – 7: 2 days

Factory setting, period 4: 3 days

temp. period 1 – 7

Setting range: 15 – 70°C

Factory setting:

Activated: deactivated

temp. period 1 20 °C

temp. period 2 30 °C

temp. period 3 40 °C

temp. period 4 45°C

temp. period 5 40 °C

temp. period 6 30 °C

temp. period 7 20 °C

Set the function for under floor drying here.

You can set up to seven period times with different calculated flow temperatures. If less than seven periods are to be used, set the remaining period times to 0 days.

Mark the active window to activate the underfloor drying function. A counter at the bottom shows the number of days the function has been active.



TIP
If operating mode „add. heat only” is to be used, select it in menu 4.2.

Menu 5.10 - change log

Read off any previous changes to the control system here. The date, time and ID no. (unique to certain settings) and the new set value is shown for every change.



NOTE

The change log is saved at restart and remains unchanged after factory setting.

Menu 5.11 - slave settings

Settings for installed slaves can be made in the sub menus.



NOTE

The SHK 20-200 unit cannot be cascaded with heat pumps.

Menu 5.11.1 - EB101

Make settings for the installed slaves here.

Menu 5.11.1.1 - heat pump

Make settings for the installed slave here. To see what settings you can make, see installation manual for the relevant installed slave.

Factory setting:

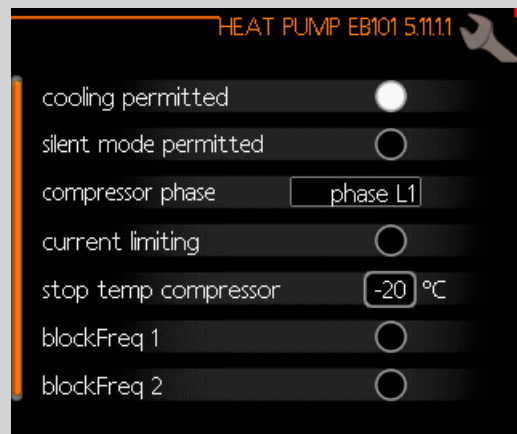

Menu 5.11.1.2 - GP12 EB101

op. mode

Heating/cooling

Setting range: auto / intermittent

Factory setting: auto

Set the operating mode for the charge pump here.

auto: The charge pump runs according to the current operating mode for the controller.

intermittent: The charge pump starts and stops 20 seconds before and after the compressor in the heat pump

speed during operation

heating, hot water, pool, cooling

Setting range: auto / manual

Factory setting: auto

Factory setting:

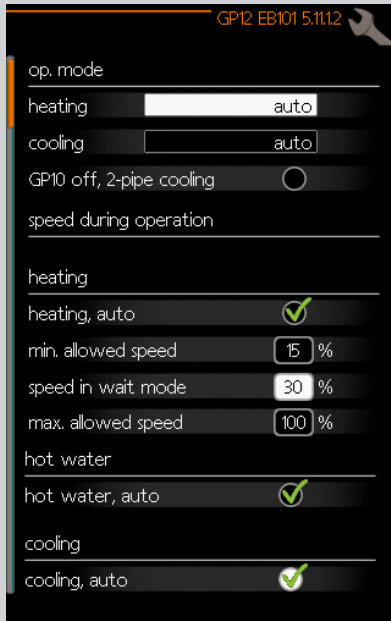

This menu allows setting the rotations with which the GP12 circulating pump is to run in the current operating mode. In „auto“ mode, the speed of the feed pump is adjusted automatically to ensure optimal operation.

If „auto“ is activated for heating operation, you can also make the setting „max. allowed speed“ which restricts the charge pump and does not allow it to run at a higher speed than the set value.

For manual operation of the charge pump deactivate „auto“ for the current operating mode and set the value to between 1 and 100 % (the previously set value for „max. allowed speed“ no longer applies).

In this menu, we can set the maximum and minimum speeds of the circulation pump. The settings depend on the central heating system.

NOTE
 Changes to settings in menu 5.11 can only be edited by qualified personnel/service.

Despite the entered settings for cooling mode, cooling is not active. To activate cooling, see the section „Cooling settings“.

5.12 - country

Select here where the product was installed. This allows access to country specific settings in your product. Language settings can be made regardless of this selection.

Cooling settings

In the factory settings of the SHK 20-200 the cooling is deactivated and requires activation in menu 5.11.1 in order to start it up.

Factory setting:

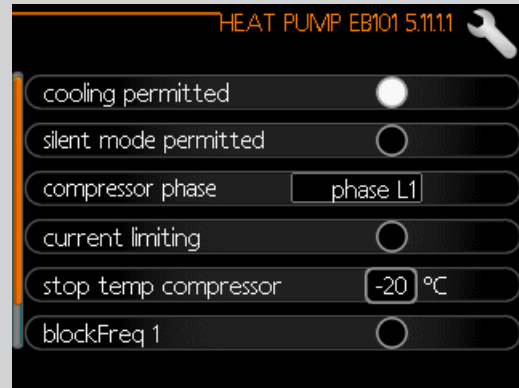

NOTE
 By default, cooling works in the 2-pipe system. In order to change the cooling mode to 4-pipe, it must be activated in menu 5.2.4.

To start up cooling, change the “start cooling” parameter in menu 4.9.2 to the higher value (applies to the outside temperature) which starts cooling in accordance with the settings in menu 1.9 (settings are in menu 1.9.1.2, 1.9.3.2 and 1.9.5).

Factory setting:

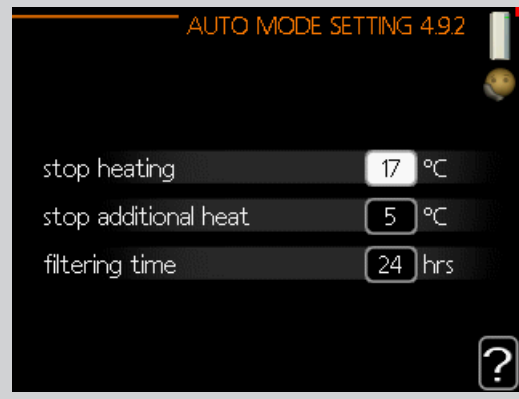

If the average temperature calculated by the “filtering time” is higher than the one set, cooling will start in accordance with the settings in menu 1.9 (settings are in menu 1.9.1.2, 1.9.3.2 and 1.9.5).

Caution
 The settings for cooling should be made based on the existing CH system. The above cooling settings can only be edited by qualified personnel.

10 Service

Service actions



NOTE

Servicing should only be carried out by persons with the necessary expertise. When replacing components in the SHK 20-200, only original spare parts should be used.

Emergency mode



NOTE

Switch (SF1) must not be put into mode „ Δ ” before the installation is filled with water. The compressor in the heat pump can be damaged.

Emergency mode is used in event of operational interference and in conjunction with service. Hot water is not produced in emergency mode.

Emergency mode is activated by setting switch (SF1) in mode „ Δ ”. This means that:

- The status lamp illuminates yellow
- The display is not lit and the control computer is not connected.
- Hot water is not produced.
- The compressors are switched off. Charge pump (EB101-GP12) (if installed) is running.
- Accessories are switched off
- The heating medium pump is active.
- The emergency mode relay (K2) is active.
- Electric module available power - 3kW.

External additional heat is active if it is connected to the emergency mode relay (K2, terminal block X1). Ensure that the heating medium circulates through the external additional heat.

Table of resistance of temperature sensors

Temperature (°C)	Resistance (k Ω)	Voltage (VDC)
-40	351,0	3,256
-35	251,6	3,240
-30	182,5	3,218
-25	133,8	3,189
-20	99,22	3,150
-15	74,32	3,105
-10	56,20	3,047
-5	42,89	2,976
0	33,02	2,889
5	25,61	2,789
10	20,02	2,673
15	15,77	2,541
20	12,51	2,399
25	10,00	2,245
30	8,045	2,083
35	6,514	1,916
40	5,306	1,752
45	4,348	1,587
50	3,583	1,426
55	2,968	1,278
60	2,467	1,136
65	2,068	1,007
70	1,739	0,891
75	1,469	0,758
80	1,246	0,691
85	1,061	0,607
90	0,908	0,533
95	0,779	0,469
100	0,672	0,414

USB service outlet

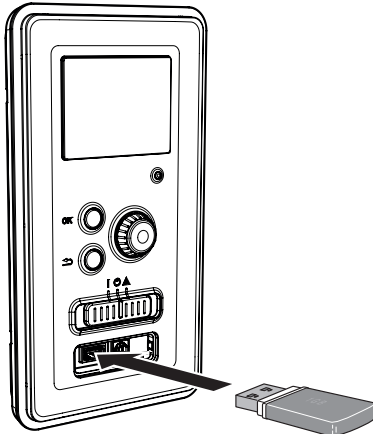

The display unit is equipped with a USB socket that can be used to update the software, save logged information and manage the settings in the controller.

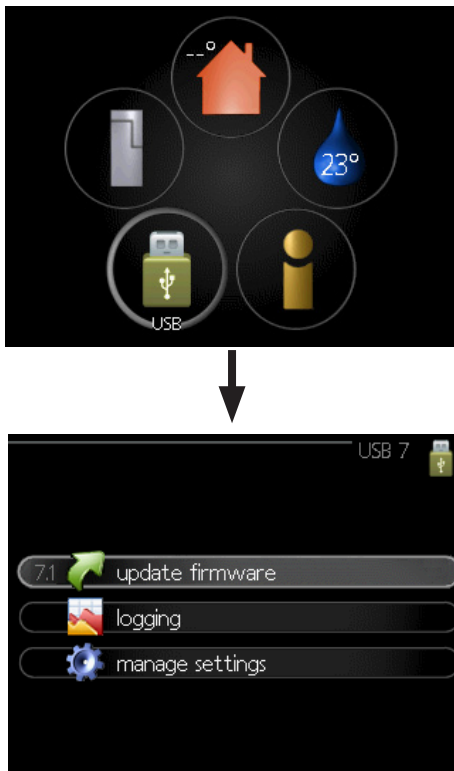

When a USB memory is connected a new menu (menu 7) appears in the display.

Menu 7.1 - update firmware

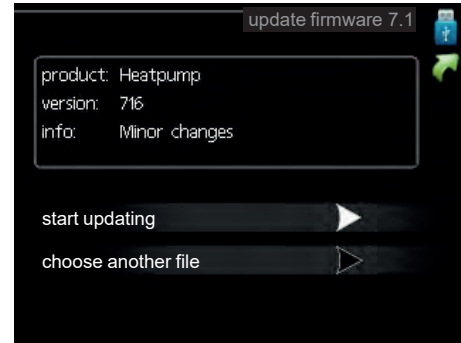

This allows you to update the software in the controller.

NOTE
For the following functions to work the USB memory must contain files with software for the controller.

The fact box at the top of the display shows information of the most probable update that the update software has selected from the USB memory.

This information states which product the software is intended for, the software version and general information about them. If you wish to select another file than the one selected, the correct file can be selected by „choose another file“.

start updating

Select “start updating” if you want to start the update. You are asked whether you really want to update the software. Respond „yes” to continue or „no” to undo.

If you responded “yes” to the previous question the update starts and you can now follow the progress of the update on the display. When the update is complete the controller restarts.

NOTE
A software update does not reset the menu settings in the controller.

NOTE
If the update is interrupted before it is complete (for example power cut etc.), the software can be reset to the previous version if the OK button is held in during start up until the green lamp starts to illuminate (takes about 10 seconds).

Choose another file



Select "choose another file" if you do not want to use the suggested software. When you scroll through the files, information about the marked software is shown in a fact box just as before. When you have selected a file with the OK button you will return to the previous page (menu 7.1) where you can choose to start the update.

Menu 7.2 - logging



Setting range: 1 s – 60 min
Factory setting range: 5 s

Here you can choose how current measurement values from the controller should be saved onto a log file on the USB memory.

1. Set the desired interval between loggings.
2. Tick "activated".
3. The present values from the controller are saved in a file in the USB memory at the set interval until "activated" is unticked.

NOTE
Untick „activated“ before removing the USB memory. Otherwise, saved data may be lost.

Menu 7.3 - manage settings

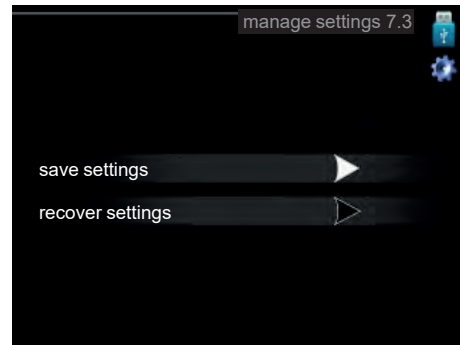

Here you can manage (save as or retrieve from) all the menu settings (user and service menus) in the controller with a USB memory.

Via „save settings“ you save the menu settings to the USB memory in order to restore them later or to copy the settings to another controller.

NOTE
When you save the menu settings to the USB memory you replace any previously saved settings on the USB memory.

NOTE
Reset of the menu settings from the USB memory cannot be undone.

Emptying the hot water tank

For emptying the hot water tank the siphon principle applies. This can be done via the drain valve on the cold water supply pipe or by placing a hose in the cold water connection.

Emptying the heating system

To facilitate the servicing of the heating system, it must first be emptied using the filling valve.

1. Connect the hose to the external drain valve of the system.
2. Then open the drain valve to empty the heating system.



NOTE

When emptying the side of the heating medium / heating system, remember that they may contain hot water. There is a risk of burns.

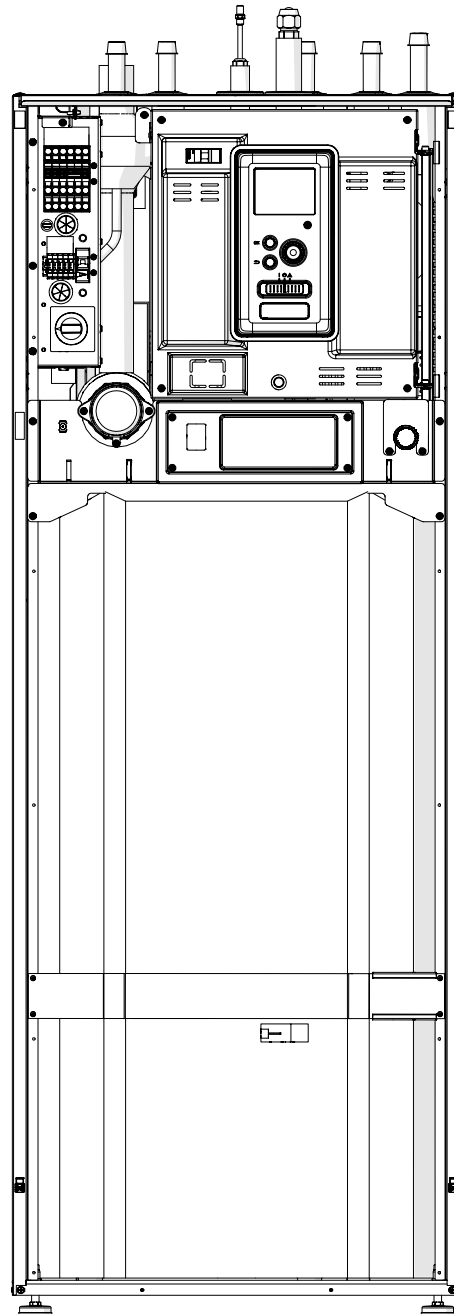

11 Disturbances in comfort

In most cases, the control module notes a malfunction and indicates this with alarms and shows instructions to rectify it in the display. See „Manage alarm” for information about managing alarms. If the malfunction does not appear in the display, or if the display is not lit, the following troubleshooting guide can be used.

In the event of an alarm, some kind of malfunction has occurred, which is indicated by the status lamp changing from green continuously to red continuously. In addition, an alarm bell appears in the information window.

Alarm

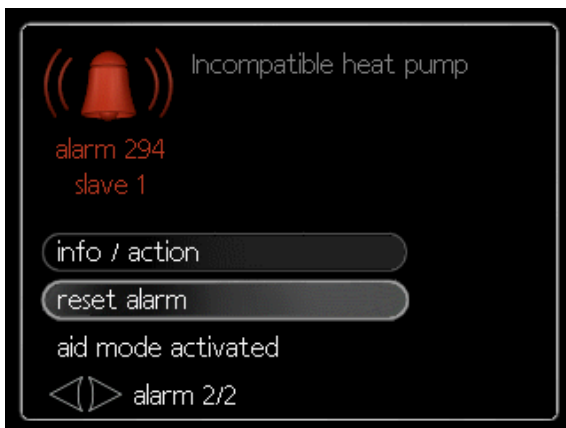

In the event of an alarm with a red status lamp a malfunction has occurred that the heat pump and/or control module cannot remedy itself. In the display, by turning the control knob and pressing the OK button, you can see the type of alarm it is and reset it. You can also choose to set the installation to aid mode.

info / action Here you can read what the alarm means and receive tips on what you can do to correct the problem that caused the alarm.

reset alarm In many cases, it is sufficient to select “reset alarm” in order for the product to revert to normal operation. If a green light comes on after selecting “reset alarm”, the alarm has been remedied. If a red light is still visible and a menu called “alarm” is visible in the display, the problem that caused the alarm remains. If the alarm disappears and then returns, contact the installer.

reset alarm “aid mode” is a type of emergency mode. This means that the installation produces heat and/or hot water despite there being some kind of problem. This can mean that the heat pump’s compressor is not running. In this case any electrical addition produces heat and/or hot water.

Caution

Selecting „aid mode” is not the same as correcting the problem that caused the alarm. The status lamp will therefore continue to be red.

If the alarm has not been reset, contact the installer for proper repair.



NOTE

When reporting a fault, always enter the serial number of the product (14 digits) found on the nameplate (PF1).

Troubleshooting

If the operational interference is not shown in the display the following tips can be used:

Basic actions

Start by checking the following items:

- The switch’s position.
- Group and main fuses of the accommodation.
- The control module’s miniature circuit breaker.
- Correctly set load monitor (if installed).

Low hot water temperature or no hot water

This part of the fault-tracing chapter only applies if the water heater is installed in the system.

- Closed or choked filling valve for the hot water.
 - Open the valve.
- Mixing valve (if there is one installed) set too low.
 - Adjust the mixer valve.
- Control module in incorrect operating mode.
 - If mode „manual” is selected, select „addition”.
- Large hot water consumption.
 - Wait until the hot water has heated up. Temporarily increased hot water capacity (temporary lux) can be activated in menu 2.1..
- Too low hot water setting.
 - Enter menu 2.2 and select a higher comfort mode
- Too low or no operating prioritisation of hot water.
 - Enter menu 4.9.1 and increase the time for when hot water is to be prioritised.

Low room temperature

- Closed thermostats in several rooms.
 - Set the thermostats to max, in as many rooms as possible.
- Adjust the room temperature via menu 1.1, instead of choking the thermostats.
- Control module in incorrect operating mode.
 - Enter menu 4.2. If mode „auto” is selected, select a higher value on „stop heating” in menu 4.9.2.
 - If mode „manual” is selected, select „heating”. If this is not enough, select „addition”.
- Too low set value on the automatic heating control.
 - Enter menu 1.1 „temperature” and adjust the offset heating curve up. If the room temperature is only low in cold weather the curve slope in menu 1.9.1 „heating curve” needs adjusting up.

- Too low or no operating prioritisation of heat.
 - Enter menu 4.9.1 and increase the time for when heating is to be prioritised.
- „Holiday mode” activated in menu 4.7.
 - Enter menu 4.7 and select „Off”.
- External switch for changing the room heating activated.
 - Check any external switches.
- Air in the climate system.
 - Vent the climate system.
 - Open the valves (contact the installer to locate them).

High room temperature

- Too high set value on the automatic heating control.
 - Enter menu 1.1 (temperature) and reduce the offset heating curve. If the room temperature is only high in cold weather the curve slope in menu 1.9.1 „heating curve” needs adjusting down.
- External switch for changing the room heating activated.
 - Check any external switches.

The compressor does not start

- There is no heating requirement.
 - The controller does not call on heating or hot water.
- Compressor blocked due to the temperature conditions.
 - Wait until the temperature is within the product's working range.
- Minimum time between compressor starts has not been reached.
 - Wait 30 minutes and then check if the compressor has started.
- Alarm tripped.
 - Follow the display instructions.

Additional heating only

If you are unsuccessful in rectifying the fault and are unable to heat the house, you can, whilst waiting for assistance, continue running the heat pump in "add. heat only". This means that additional heating only is used to heat the house.

Set the installation to additional heat mode

1. Go to menu 4.2 op. mode.
2. Mark "add. heat only" using the control knob and then press the OK button.
3. Return to the main menus by pressing the Back button.



Caution

When commissioning without METRO THERM air/water heat pump, the communication error alarm may appear in the display. The alarm is reset if the relevant heat pump is deactivated in menu 5.2.2 („installed slaves”).

12 Accessories

Automatic gas separator AGS 10

Intended for METROAIR L10.1 / SHK 20-200/12. An automatic air separator must be installed when the length of the pipe between METROAIR L10.1 and SHK 20-200/12 air/water heat pump exceeds 15 m.

Part no. 067 829

Room sensor RTS 40

This accessory is used to obtain a more even indoor temperature.

Part no. 067 065

Extra shunt group ECS 40/ECS 41

This accessory is used when the controller is installed in houses with two or more different heating systems that require different supply temperatures.

ECS 40 (maks. 80m²)

Part no. 067 287

ECS 41 (maks. 250m²)

Part no. 067 288

Accessory card AXC 30

An accessory board is required in case of active cooling (4-pipe system), an additional climate system, or if more than four feed pumps are to be connected to the controller. It can also be used in case of additional heat controlled by a shunt valve (e.g. wood/oil/gas/pellet boiler). An accessory board is required if, for example, a hot water circulation pump is to be connected to the controller where the AA3-X7 output is activated for the QN12 valve.

Part no. 067 304

Communications module MODBUS 40

MODBUS 40 enables controller to be controlled and monitored using a BMS (building management system) in the building. Communication is then performed using MODBUS-RTU.

Part no. 067 144

Room unit RMU 40

RMU 40 means that control and monitoring of the controller can be carried out in a different part of your home to where it is located.

Part no. 067 064

Pool unit POOL 40

POOL 40 is used to enable pool heating with SHK 20-200.

Part no. 067 062

Air/water heat pump

L6.1

Part no. 31491

L10.1

Part no. 31495

Condensation water drainage pipe

KVR10-10

Length - 1 meter

Part no. 067 614

KVR10-30

Length - 3 metres

Part no. 067 616

KVR10-60

Length - 6 meters

Part no. 067 618

More accessories are available on the website

<https://www.nathan.nl>

Connecting the KVR accessory

The KVR 10 accessory is used to safely drain off most of the condensate from the air/water heat pump to a frost-free collection point.

HYDRAULIC CONNECTION

For information on hydraulic connection of the KVR 10 accessory, see the instructions for the KVR accessory.

ELECTRICAL CONNECTION

In order to connect the electric KVR accessory:

1. Open the control panel and knock out the notched plate in the control panel housing under the residual current device. Remove the panel housing.
2. Disconnect the wires and remove the cube. Fix the residual current device on the bar.

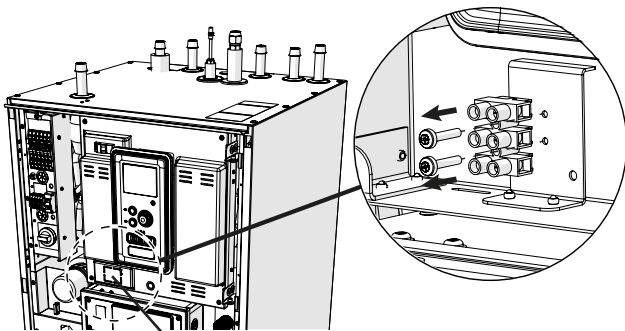
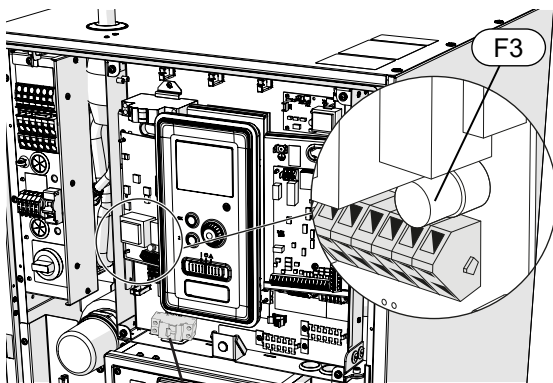

Plate to be punched-out

3. Use fuse (F3) depending on the length of the KVR cable in accordance with the below table.



Residual-current device RCD

Length (m)	P _{tot} (W)	Fuse (F3)	Part no.
1	15	T100mA/250V	718 085
3	45	T250mA/250V	518 900*
6	90	T500mA/250V	718 086

*Fitted at the factory

4. Connect a residual-current device to terminal AA2-X1 under terminal block 5(N) and 6(L).

5. Connect a residual-current device to terminal AA23-X1 to terminal blocks 1 (L) and 2 (N).
6. Connect an external heating cable (EB14) to terminal AA23-X1 to terminal blocks: 4 (PE), 5 (N), 6 (L).

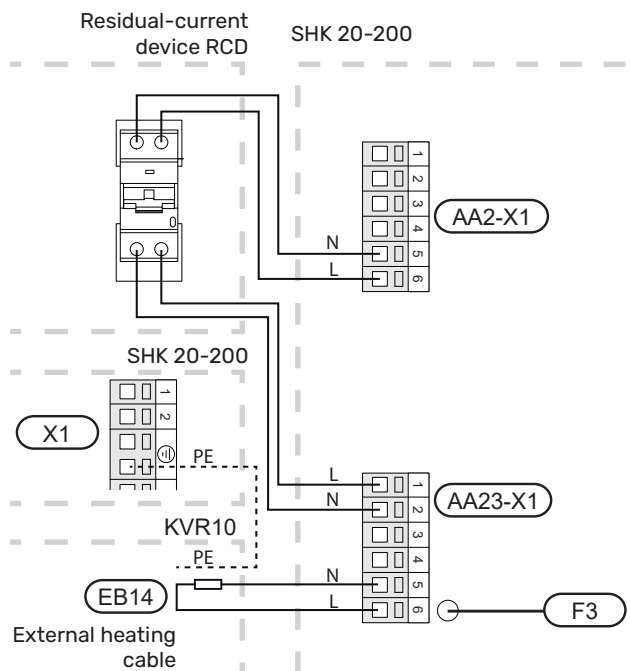
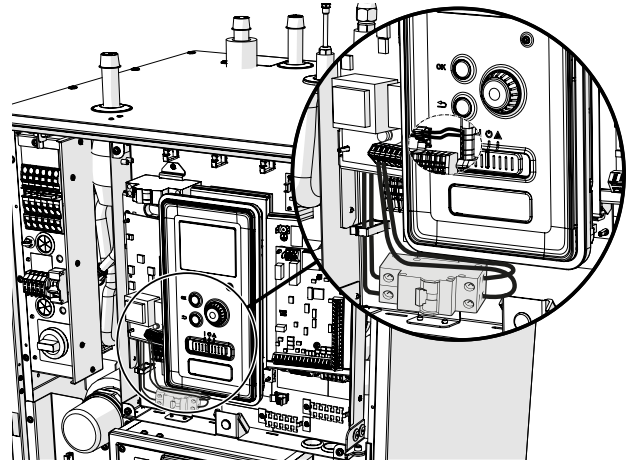

Connecting an additional heat source

The SHK 20-200 can be connected to an additional heat source (e.g. a gas boiler, solid fuel boiler).

NOTE
 When using an additional heat source (e.g. gas boiler, solid fuel boiler), the built-in electric auxiliary heater will not be used.

Additional heat source connected before QN10 (replacing the built-in auxiliary heater) must not have a power greater than 15 kW and should be connected to the contactor K1A. Short-circuit of potential-free contacts K1A gives a signal to switch on an additional heat source.

HYDRAULIC CONNECTION

The hydraulic connection should be made to connections XL 18 and 19 in accordance with „Diagram showing connection of an additional heat source” in section 4 Pipe connections.

ELECTRICAL CONNECTION

In order to make a correct electrical connection to the control (potential-free):

1. Disconnect the device from the power supply.
2. In the case of connecting the unit to 400V, convert the connection to 230V.
3. Disconnect the B02 jumper as shown in the drawing below (detailed diagram in the subsection „Wiring diagrams”).
4. Connect the wires from the additional heat source (e.g. gas boiler) to the terminals of the K1A: 3 and K1A: 4 relay as shown in the figure below.

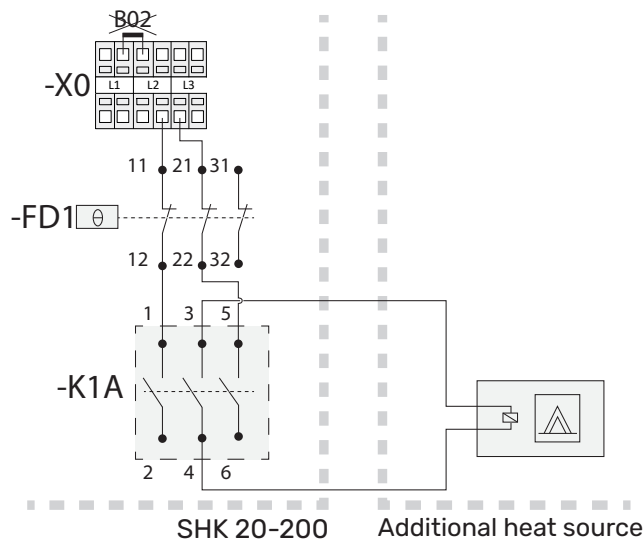

5. Connect the device to the power supply and start the SHK unit.
6. In menu 5.1.12, change the setting according to the screenshot and description below.

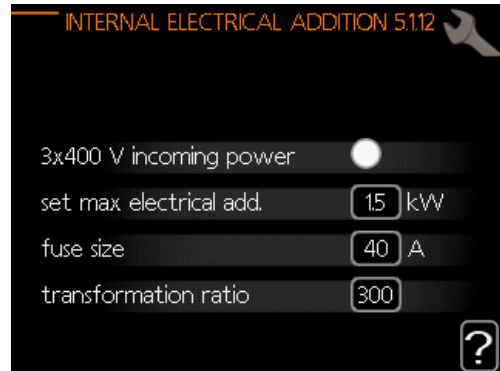

Description of settings:
 3x400 V incoming power: off
 set max electrical add.: 1.5 kW
 fuse size: 40A (recommended value)
 transformation ratio: 300

Caution
 To run an additional heat source (e.g. a gas boiler), the fuse size must be set at least 7A higher than the required compressor run value

In the absence of current limitation, the recommended fuse size is 40A.

NOTE
 Setting the fuse size too low may result an wrong operation in additional heat source and/or compressor power limitation.

Connecting the expansion card

Communication connection

The expansion card communication should be connected directly to the SHK 20-200 to the AA23 card according to the diagram below.

When connecting or installing more than one accessory, observe the following.

The first expansion card should be connected directly to the AA23-X4 terminal block on the SHK 20-200, and the following cards should be connected in series with the previous one.

Use cables type LiYY, EKKX or similar.

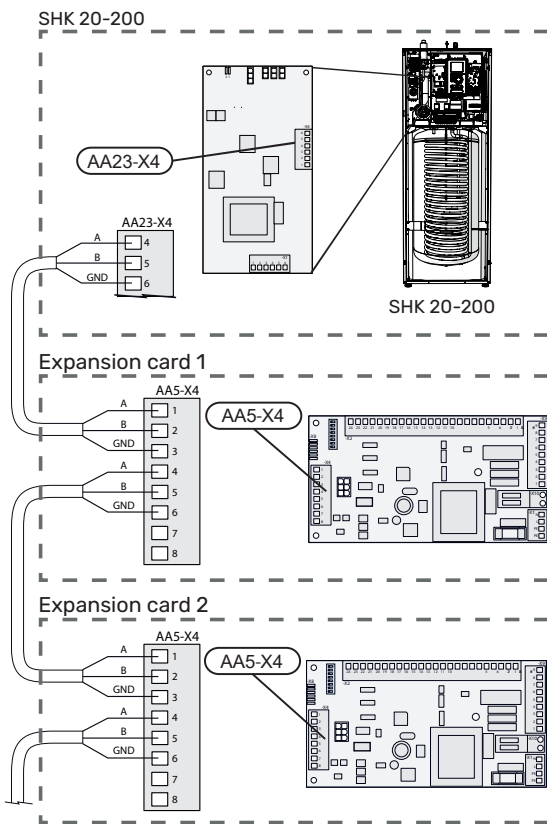

For detailed information on using the expansion card, see the installer manual for the AXC 30 accessory.

Power connection

Connect the power to terminal X1 as shown in the figure.

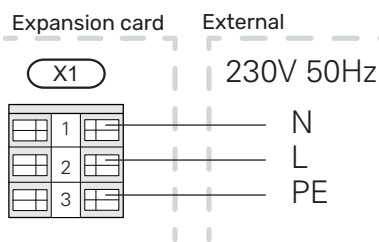

Connection of an additional GP10 pump

To connect an additional GP10 circulation pump, proceed as follows:

- connect wire L to the terminal block AA2-X4: 11
- connect wire N to the terminal block AA2-X4: 10
- connect wire PE to the terminal AA2-X4: 9

All connections should be made in accordance with the figure below.

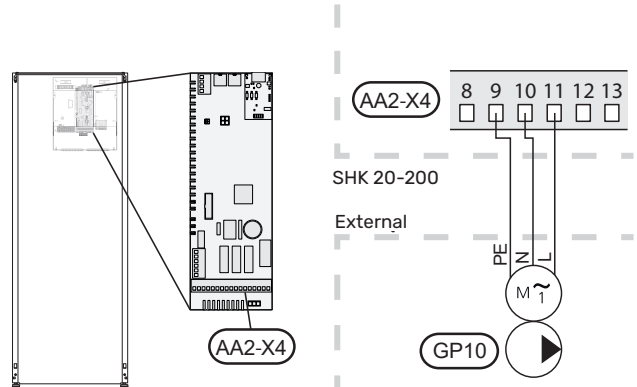
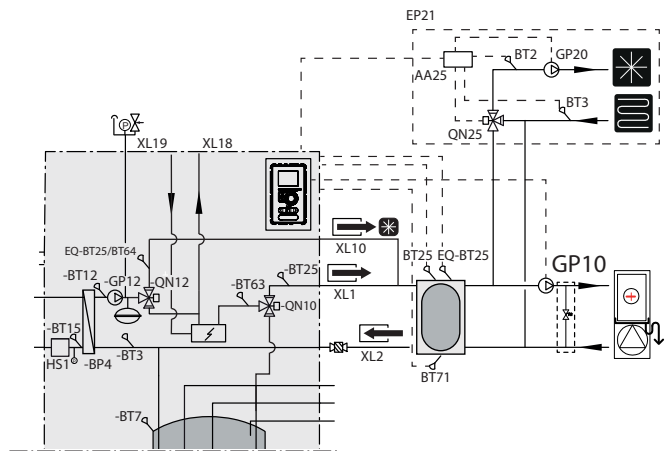
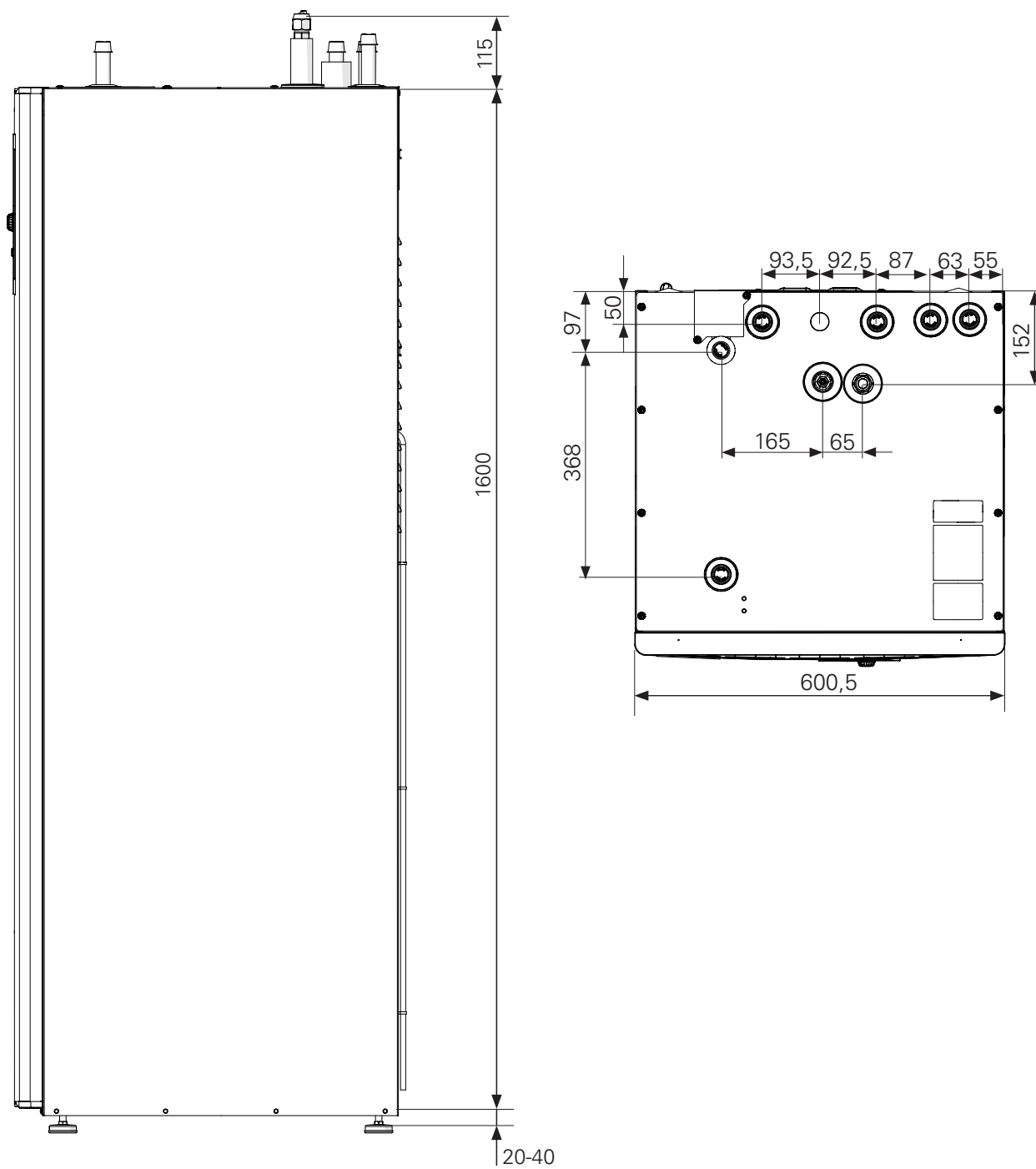

Diagram with buffer tank connected in series-parallel and additional circulation pump GP10.



13 Technical data



Technical data

SHK 20-200

Product type	Unit	SHK 20-200/6	SHK 20-200/12
Height	mm	1720	
Required room height	mm	2100	
Width	mm	600	
Depth	mm	610	
Weight	kg	155	165
Maximum operating pressure of central heating system.	bar	3	
Maximum hot water pressure	bar	10	
Hot water tank volume	l	180	
Maximum operating temperature of central heating	°C	70	
Maximum hot water temperature	°C	65	
Low-energy circulation pump clim. sys.	-	Yes	
Safety valve. climate system	-	Yes, in the safety assembly	
Expansion vessel	l	10	
Additional heat	kW	4,5 (230 V) / 9 (400 V)	
Plate heat exchanger power	kW	6	9
Rated voltage	V	1x230 / 3x400	
Hot water tank corrosion protection	-	Enamel + titanium anode	
Refrigerant type	-	R32	
Maximum hot water capacity in accordance with EN16147	-	230 l 40°C	
Energy class (acc. to ErP, at supply temp. 55°C) (Applies to L10.1 + SHK 20-200/12 i L6.1 + SHK 20-200/6)	-	A++	
Performance class / Load profile (DHW)	-	A/XL	

METROAIR L

Outdoor module	Unit	L6.1	L10.1
Output data according to EN 14 511, partial load ¹			
Heating	-7 / 35°C	5.55 / 2.05 / 2.71	7.18 / 2.93 / 2.45
Capacity / power input / COP (kW/kW/-) at nominal flow Outdoor temp. / Supply temp.	2 / 35°C	2.31 / 0.56 / 4.13	3.46 / 0.83 / 4.17
	2 / 45°C	2.02 / 0.67 / 3.01	3.24 / 1.12 / 3.24
	7 / 35°C	2.64 / 0.49 / 5.42	4.00 / 0.75 / 5.33
	7 / 45°C	2.43 / 0.65 / 3.74	5.00 / 1.28 / 3.91
Cooling Capacity / power input / EER (kW/kW/-) at maximum flow Outdoor temp. / Supply temp.	35 / 7 °C	5.32 / 1.94 / 2.74	7.07 / 2.40 / 2.95
	35 / 18 °C	7.55 / 2.11 / 3.58	10.79 / 3.00 / 3.60
SCOP according to EN 14825			
Nominal heat output ($P_{designh}$) average climate 35 °C / 55 °C (Europe)	kW	5.20 / 5.60	6.3 / 6.5
Nominal heat output ($P_{designh}$) cold climate 35 °C / 55 °C	kW	5.80 / 5.70	6.5 / 6.2
Nominal heat output ($P_{designh}$) warm climate 35 °C / 55 °C	kW	5.57 / 5.48	6.9 / 6.6
SCOP average climate, 35 °C / 55 °C (Europe)		5.08 / 3.58	4.6 / 3.4
SCOP cold climate, 35 °C / 55 °C		4.10 / 3.05	3.9 / 2.9
SCOP warm climate, 35 °C / 55 °C		6.76 / 4.55	6.4 / 4.4
Energy rating, average climate ²			
The product's room heating efficiency class 35 C / 55 C ³		A++ / A++	
The system's room heating efficiency class 35 C / 55 C ⁴		A+++ / A++	
Electrical data			
Rated voltage		230 V 50 Hz, 230 V 2 AC 50 Hz	
Max operating current, heat pump	A_{rms}	15	16
Max operating current, compressor	A_{rms}	14	15
Max. power, fan	W	50	86
Drain pan heating (integrated)	W	110	100
Fuse	A_{rms}	16	
Starting current	A_{rms}	5	
Enclosure class		IP24	
Refrigerant circuit			
Type of refrigerant		R32	
GWP refrigerant		675	
Volume	kg	1.3	1.84
Type of compressor		Twin Rotary	
CO ₂ -equivalent (The cooling circuit is hermetically sealed.)	t	0.88	1.24
Cut-out value pressure switch HP (BP1)	MPa (bary)	-	4,15 (41,5)
Cut-out value pressure switch LP (BP2)	MPa (bary)	-	0,079 (0,79)
Max. length, refrigerant pipe, one way	m	30	50
Max height difference, when METROAIR L is placed higher than SHK 20-200	m	20	30
Max height difference, when METROAIR L is placed lower than SHK 20-200	m	20	15

Dimensions, refrigerant pipes, Gas pipe/Liquid pipe ⁵	mm	12.7 (1/2") / 6.35 (1/4")	15.88 (5/8") / 6.35 (1/4")
Airflow			
Max airflow	m ³ /h	2,530	3,000
Working area			
Min./max. air temperature, heating	°C	-20 / 43	
Min./max. air temperature, cooling	°C	15 / 43	
Defrosting system		Reverse cycle	
Pipe connections			
Pipe connection option		Right-hand side	
Pipe connections		Flare	
Dimensions and weight			
Width	mm	800	880 (+67 valve cover)
Depth	mm	290	340 (+ 110 with foot rail)
Height with stand	mm	640	750
Weight	kg	46	60
Miscellaneous			
Part no.		31491	31495

¹ Power statements including defrosting according to EN 14511 at heating medium supply corresponding to DT=5 K at 7 / 45.

² Reported efficiency for the system also takes the temperature regulator into account. If the system is supplemented with an external auxiliary boiler or solar heating, the total efficiency of the system must be recalculated.

³ Scale for the product's room heating efficiency class A++ to G. Control module model SMO S.

⁴ Scale for the system's room heating efficiency class A+++ to G. Control module model SMO S.

⁵ If the length of the refrigerant pipes exceeds 15 metres, extra refrigerant must be added at 0.02 kg/m. Use the enclosed label to re-mark the unit with the new amount of refrigerant.

Max. operating current and recommended fuse rating for 3x400 V connection	Unit	SHK 20-200/6 + L6.1	SHK 20-200/12 + L10.1
Max. operating current, compressor	A	16	16
Max. operating current of heat pump including 3 kW immersion heater, compressor running and contactor K1 connected (recommended fuse rating)	A	16 (16)	16 (16)
Max. operating current of heat pump including 6 kW immersion heater, compressor running and contactor K1+K2 connected (recommended fuse rating)	A	16 (16)	16 (16)
Max. operating current of heat pump including 9 kW immersion heater, compressor running and contactor K1+K2+K3 connected (recommended fuse rating)	A	20 (20)	20 (20)
Max. operating current of 9 kW immersion heater, contactor K1+K2+K3 connected, compressor not running (recommended fuse rating)	A	20 (20)	20 (20)

Max. operating current and recommended fuse rating for 1x230 V connection	Unit	SHK 20-200/6 + L6.1	SHK 20-200/12 + L10.1
Max. operating current, compressor	A	16	16
Max. operating current of heat pump including 1.5 kW immersion heater, compressor running and contactor K1 connected (recommended fuse rating)	A	22,5 (25)	22,5 (25)
Max. operating current of heat pump including 3 kW immersion heater, compressor running and contactor K1+K2 connected (recommended fuse rating)	A	29 (32)	29 (32)
Max. operating current of heat pump including 4.5 kW immersion heater, compressor running and contactor K1+K2+K3 connected (recommended fuse rating)	A	35,5 (32)	35,5 (32)
Max. operating current of 4.5 kW immersion heater, contactor K1+K2+K3 connected, compressor not running (recommended fuse rating)	A	19,5 (20)	19,5 (20)

Energy efficiency label

Manufacturer	METRO THERM		
Heat pump model		L6.1	L10.1
Hot water heater model		SHK 20-200/6	SHK 20-200/12
Temperature application	°C	35 / 55	35 / 55
Space heating efficiency class, average climate		A+++ / A++	
Nominal heat output ($P_{designh}$), average climate	kW	5 / 6	6 / 6
Annual energy consumption for space heating, average climate	kWh	2 116 / 3 250	2 834 / 3 961
Seasonal average space heating efficiency, average climate	%	200 / 139	181 / 132
Sound power level L_{WA} indoors	dB	35	
Rated heat output ($P_{designh}$), cold climate	kW	6 / 6	7 / 6
Rated heat output ($P_{designh}$), warm climate	kW	6 / 5	7 / 7
Annual energy consumption space heating, cold climate	kWh	3 487 / 4 604	4 059 / 5 204
Annual energy consumption space heating, warm climate	kWh	1 110 / 1 617	1 379 / 1 964
Seasonal space heating energy efficiency, cold climate	%	161 / 119	155 / 114
Water heating energy efficiency, cold climate	%	265 / 178	260 / 177
Sound power level L_{WA} outdoors	dB	54	54

Energy efficiency specifications of the package

Heat pump model		L6.1	L10.1
Hot water heater model		SHK 20-200/6	SHK 20-200/12
Temperature application	°C	35 / 55	35 / 55
Controller, class		VI	
Controller, contribution to efficiency	%	4,0	
Seasonal space heating energy efficiency of the package, average climate	%	204 / 143	185 / 136
Seasonal space heating energy efficiency class of the package, average climate		A+++ / A++	
Seasonal space heating energy efficiency of the package, cold climate	%	165 / 123	159 / 118
Seasonal space heating energy efficiency of the package, warm climate	%	269 / 182	264 / 181

A+++ - D for product space heating
 A+++ - G for package space heating
 A+ - F for product domestic hot water

The reported efficiency of the system also takes the controller into account. If an external supplementary boiler or solar heating is added to the system, the overall efficiency of the system should be recalculated.

Energy label

Model		L6.1 + SHK 20-200/6					
Type of heat pump	<input checked="" type="checkbox"/> Air-water <input type="checkbox"/> Exhaust-water <input type="checkbox"/> Brine-water <input type="checkbox"/> Water-water						
Low-temperature heat pump	<input type="checkbox"/> Yes <input checked="" type="checkbox"/> No						
Integrated immersion heater for additional heat	<input checked="" type="checkbox"/> Yes <input type="checkbox"/> No						
Heat pump combination heater	<input checked="" type="checkbox"/> Yes <input type="checkbox"/> No						
Climate	<input checked="" type="checkbox"/> Average <input type="checkbox"/> Cold <input type="checkbox"/> Warm						
Temperature application	<input checked="" type="checkbox"/> Average (55°C) <input type="checkbox"/> Low (35°C)						
Applied standards	EN14825 / EN16147, EN14511 and EN12102						
Rated heat output	Prated	5.6	kW	Seasonal space heating energy efficiency	η_s	139	%
Declared capacity for space heating at part load and at outdoor temperature T_j				Declared coefficient of performance for space heating at part load and at outdoor temperature T_j			
$T_j = -7^\circ\text{C}$	P_{dh}	5.0	kW	$T_j = -7^\circ\text{C}$	P_{dh}	1.95	-
$T_j = +2^\circ\text{C}$	P_{dh}	2.9	kW	$T_j = +2^\circ\text{C}$	P_{dh}	3.51	-
$T_j = +7^\circ\text{C}$	P_{dh}	1.9	kW	$T_j = +7^\circ\text{C}$	P_{dh}	4.99	-
$T_j = +12^\circ\text{C}$	P_{dh}	1.7	kW	$T_j = +12^\circ\text{C}$	P_{dh}	6.33	-
$T_j = \text{biv}$	P_{dh}	5.0	kW	$T_j = \text{biv}$	P_{dh}	1.95	-
$T_j = \text{TOL}$	P_{dh}	4.6	kW	$T_j = \text{TOL}$	P_{dh}	1.75	-
$T_j = -15^\circ\text{C}$ (if $\text{TOL} < -20^\circ\text{C}$)	P_{dh}		kW	$T_j = -15^\circ\text{C}$ (if $\text{TOL} < -20^\circ\text{C}$)	P_{dh}		-
Bivalent temperature	T_{biv}	-7	$^\circ\text{C}$	Min. outdoor air temperature	TOL	-10	$^\circ\text{C}$
Cycling interval capacity	P_{cyc}		kW	Cycling interval efficiency	COP-cyc		-
Degradation coefficient	C_{dh}	0.96	-	Max supply temperature	WTOL	58	$^\circ\text{C}$
Power consumption in modes other than active mode				Additional heat			
Off mode	P_{OFF}	0.007	kW	Rated heat output	P_{sup}	1.0	kW
Thermostat-off mode	P_{TO}	0.011	kW				
Standby mode	P_{SB}	0.011	kW	Type of energy input	Electric		
Crankcase heater mode	P_{CK}	0.000	kW				
Other items							
Capacity control	Variable			Rated airflow (air-water)		2 340	m^3/h
Sound power level, indoors/outdoors	L_{WA}	35 / 54	dB	Rated heating medium flow			m^3/h
Annual energy consumption	Q_{HE}	3 250	kWh	Brine flow rate in brine-water or water-water heat pumps			m^3/h

Model				L10.1 + SHK 20-200/12			
Type of heat pump		<input checked="" type="checkbox"/> Air-water <input type="checkbox"/> Exhaust-water <input type="checkbox"/> Brine-water <input type="checkbox"/> Water-water					
Low-temperature heat pump		<input type="checkbox"/> Yes <input checked="" type="checkbox"/> No					
Integrated immersion heater for additional heat		<input checked="" type="checkbox"/> Yes <input type="checkbox"/> No					
Heat pump combination heater		<input checked="" type="checkbox"/> Yes <input type="checkbox"/> No					
Climate		<input checked="" type="checkbox"/> Average <input type="checkbox"/> Cold <input type="checkbox"/> Warm					
Temperature application		<input checked="" type="checkbox"/> Average (55°C) <input type="checkbox"/> Low (35°C)					
Applied standards		EN14825 / EN16147, EN14511 and EN12102					
Rated heat output	Prated	6.5	kW	Seasonal space heating energy efficiency	η_s	132	%
Declared capacity for space heating at part load and at outdoor temperature T_j				Declared coefficient of performance for space heating at part load and at outdoor temperature T_j			
$T_j = -7^\circ\text{C}$	P _{dh}	5.8	kW	$T_j = -7^\circ\text{C}$	P _{dh}	1.98	-
$T_j = +2^\circ\text{C}$	P _{dh}	3.5	kW	$T_j = +2^\circ\text{C}$	P _{dh}	3.17	-
$T_j = +7^\circ\text{C}$	P _{dh}	2.3	kW	$T_j = +7^\circ\text{C}$	P _{dh}	4.98	-
$T_j = +12^\circ\text{C}$	P _{dh}	2.2	kW	$T_j = +12^\circ\text{C}$	P _{dh}	5.50	-
$T_j = \text{biv}$	P _{dh}	5.8	kW	$T_j = \text{biv}$	P _{dh}	1.98	-
$T_j = \text{TOL}$	P _{dh}	5.8	kW	$T_j = \text{TOL}$	P _{dh}	1.69	-
$T_j = -15^\circ\text{C}$ (if $\text{TOL} < -20^\circ\text{C}$)	P _{dh}		kW	$T_j = -15^\circ\text{C}$ (if $\text{TOL} < -20^\circ\text{C}$)	P _{dh}		-
Bivalent temperature				Min. outdoor air temperature			
	T_{biv}	-7	°C		TOL	-10	°C
Cycling interval capacity				Cycling interval efficiency			
	P _{cych}		kW		COP-cyc		-
Degradation coefficient				Max supply temperature			
	C _{dh}	0.98	-		WTOL	60	°C
Power consumption in modes other than active mode				Additional heat			
Off mode	P _{OFF}	0.003	kW	Rated heat output	P _{sup}	0.7	kW
Thermostat-off mode	P _{TO}	0.008	kW				
Standby mode	P _{SB}	0.008	kW	Type of energy input	Electric		
Crankcase heater mode	P _{CK}	0	kW				
Other items							
Capacity control	Variable			Rated airflow (air-water)		3 000	m ³ /h
Sound power level, indoors/outdoors	L _{WA}	35 / 54	dB	Rated heating medium flow			m ³ /h
Annual energy consumption	Q _{HE}	3 961	kWh	Brine flow rate in brine-water or water-water heat pumps			m ³ /h

Electrical wiring diagrams

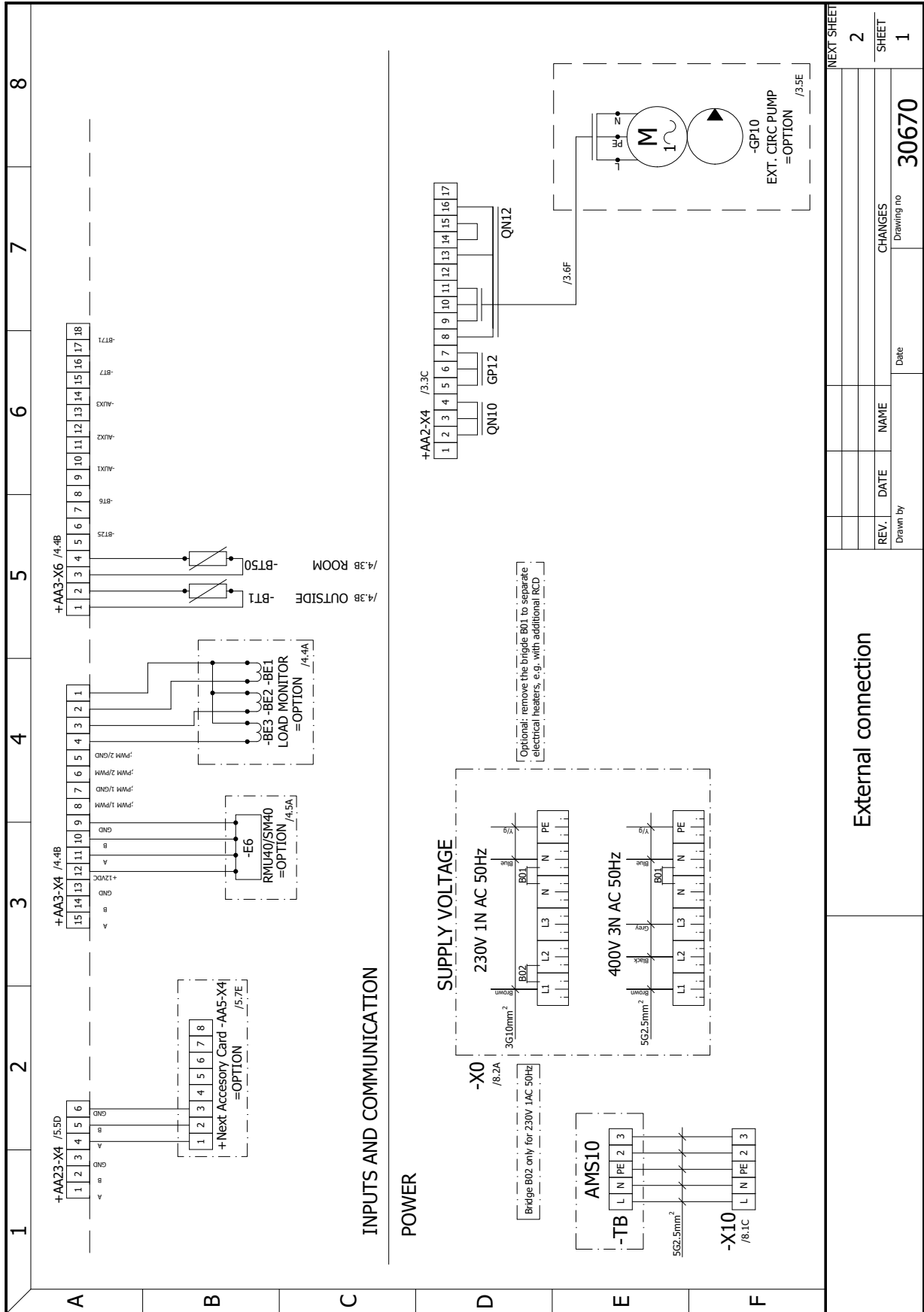

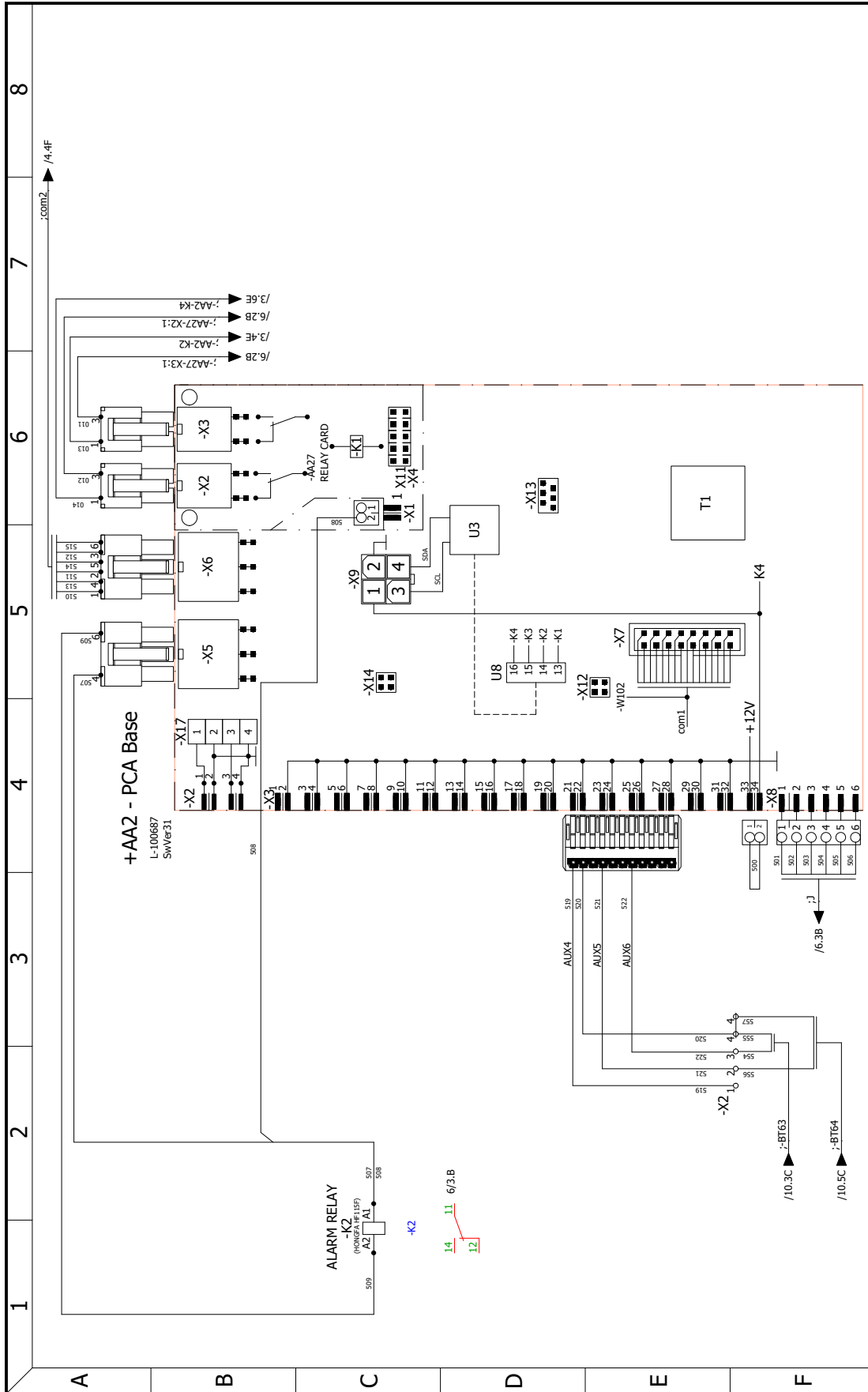

AA2 PCA Base I/O		REV.	DATE	NAME	CHANGES	Drawing no	30670
		Drawn by				Date	
NEXT SHEET		3					
		SHEET					2

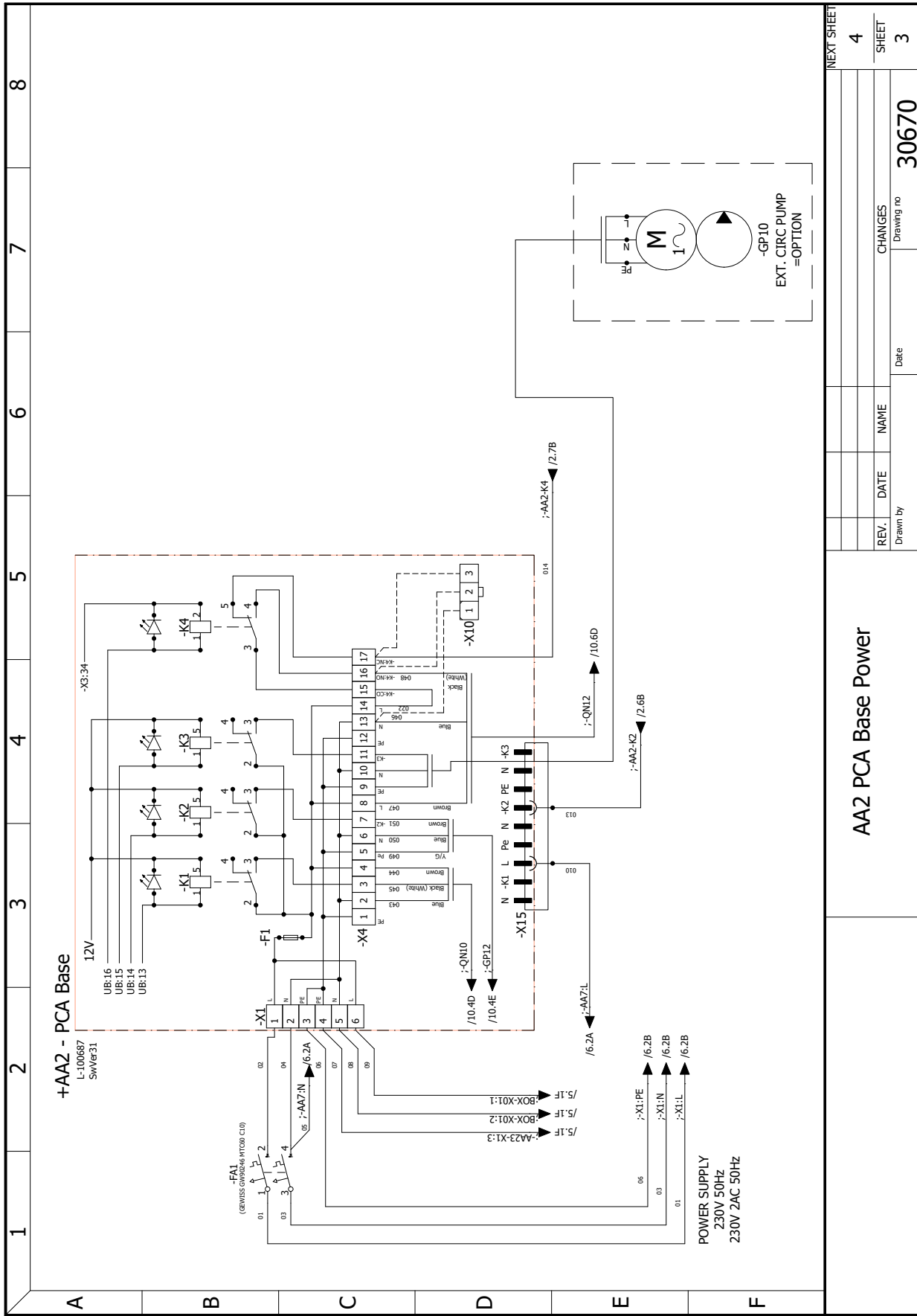

AA2 PCA Base Power

REV.	DATE	NAME	CHANGES
4			
3			

Drawing no **30670**
 Date

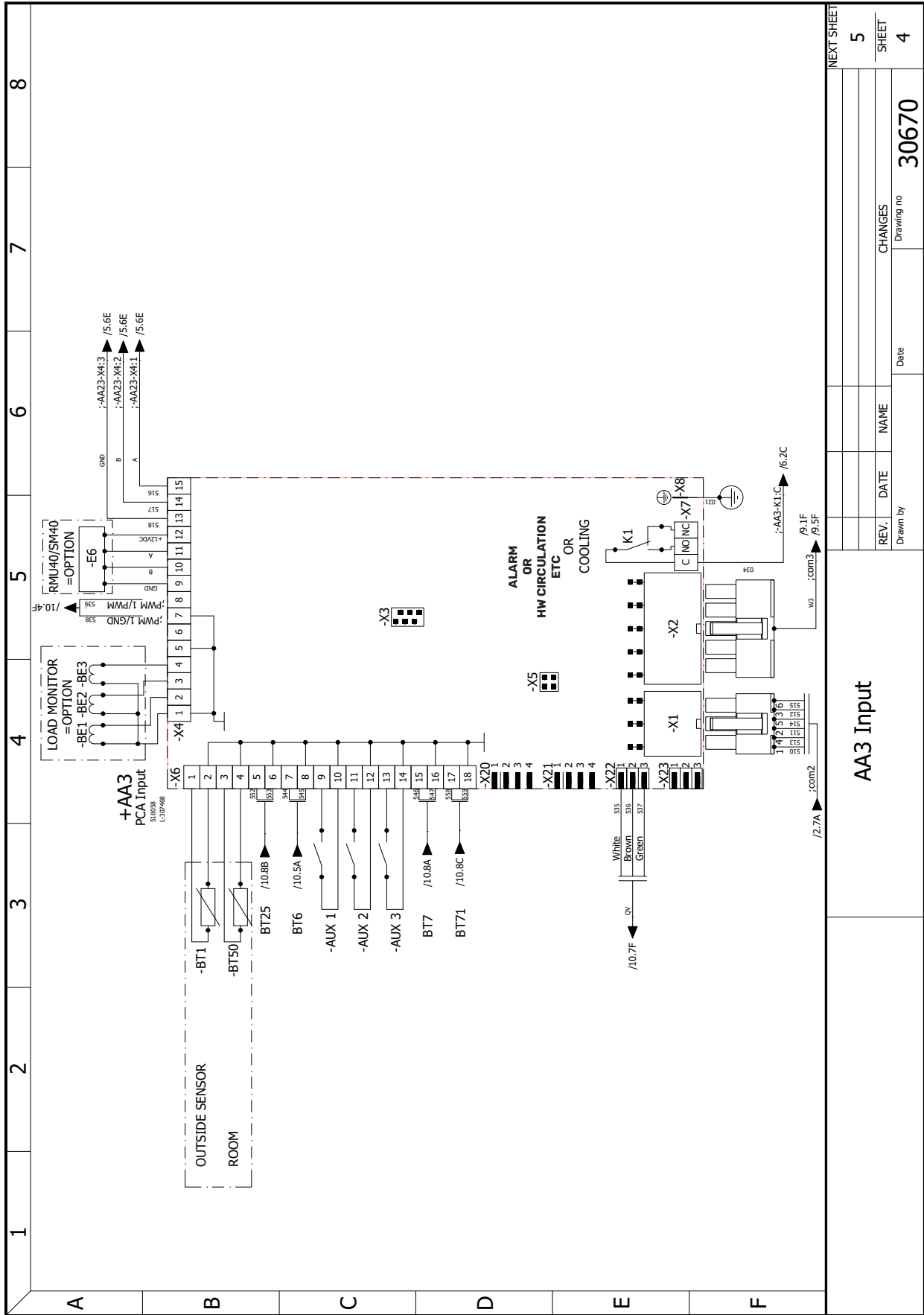

AA3 Input

REV.	DATE	NAME	CHANGES	Drawing no
				30670
				Date
				Drawn by

REV.	DATE	NAME	CHANGES	Drawing no
				30670
				Date
				Drawn by

NEXT SHEET	5
SHEET	4

1 2 3 4 5 6 7 8

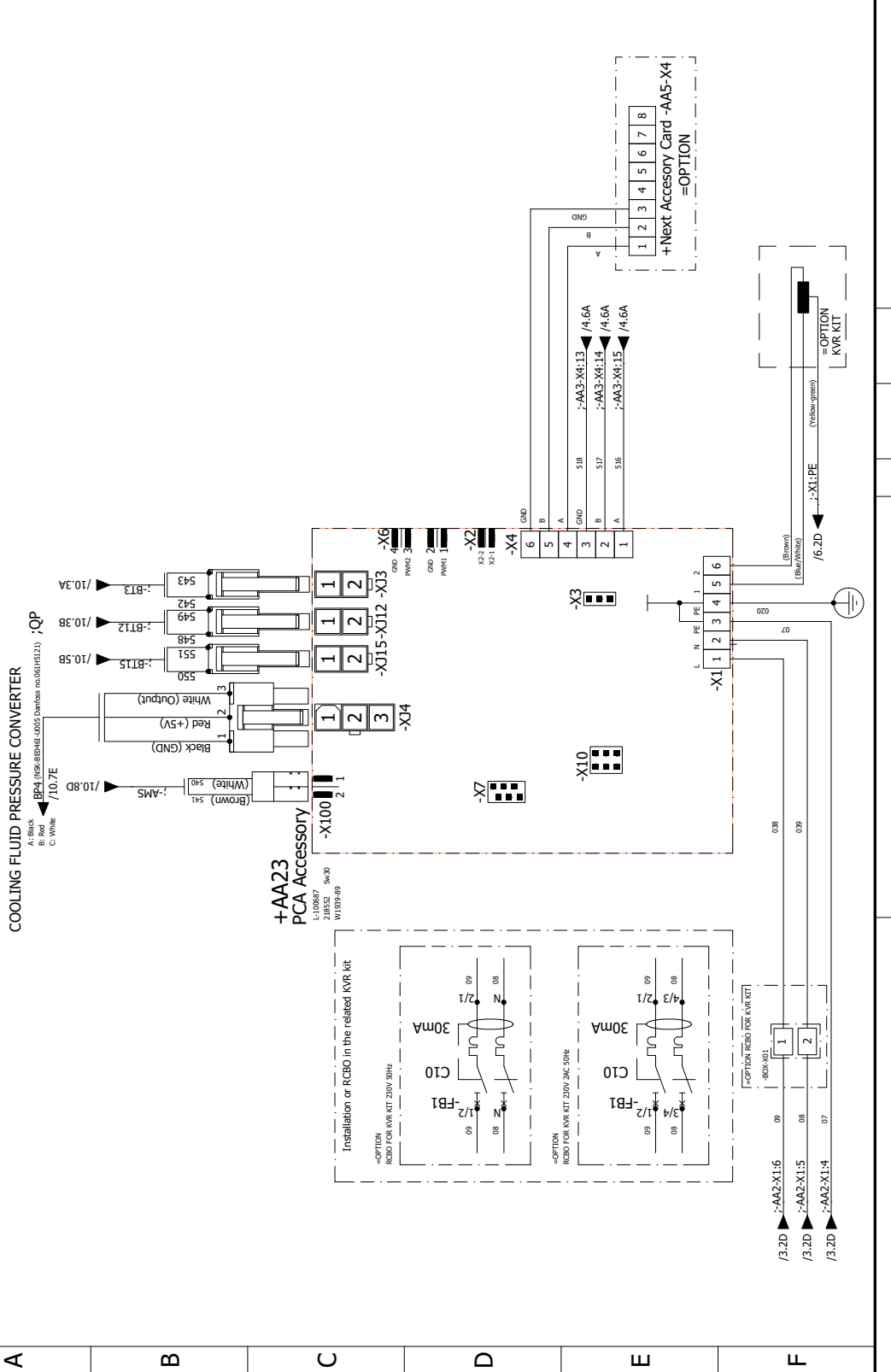

AA23 PCA Accessory			REV.	DATE	NAME	Date
			Drawn by			
CHANGES						30670
Drawing no						5
NEXT SHEET						6
SHEET						5

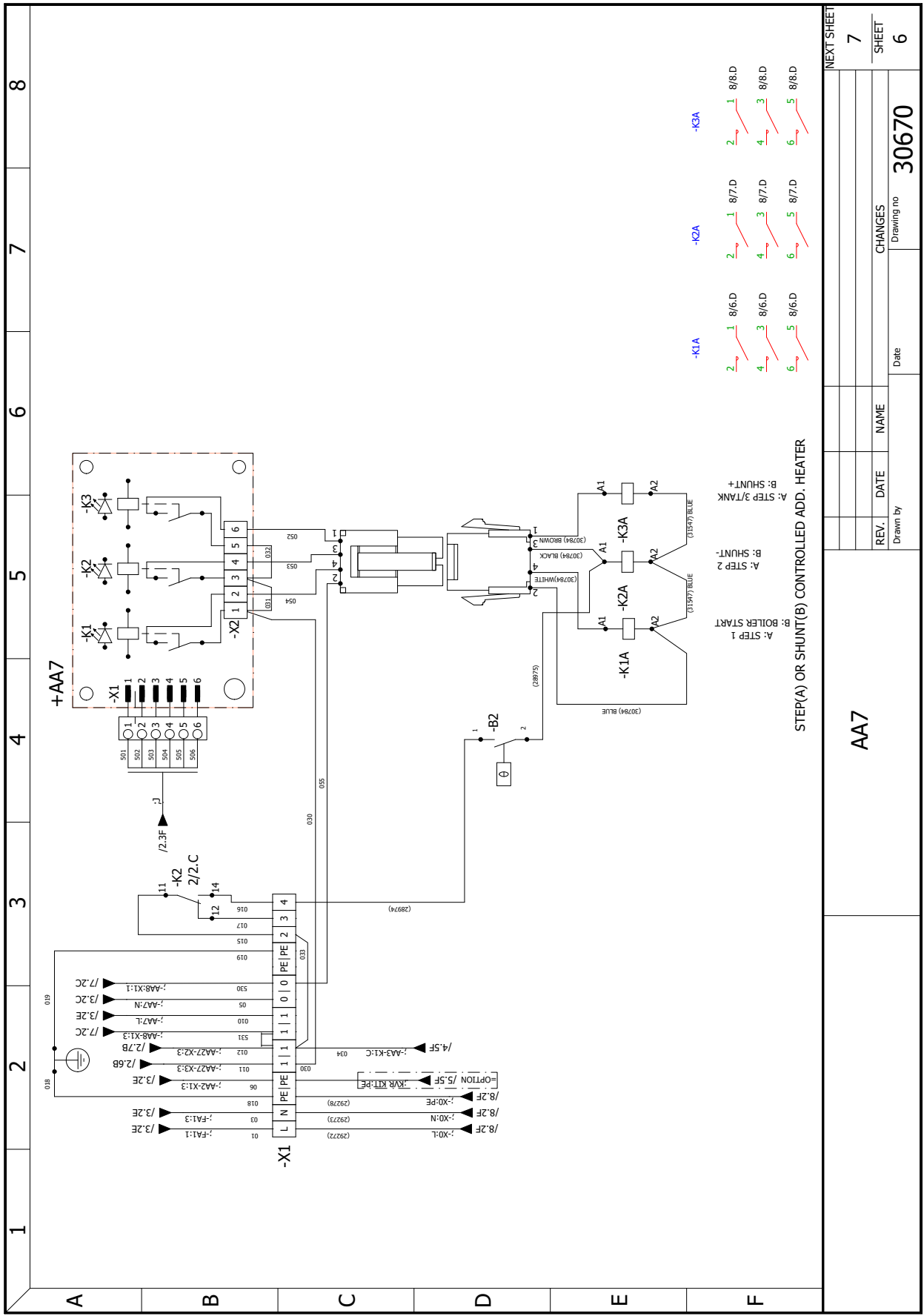

AA7		NEXT SHEET	
		7	SHEET
CHANGES		Drawing no	
		30670	
AA7		Date	

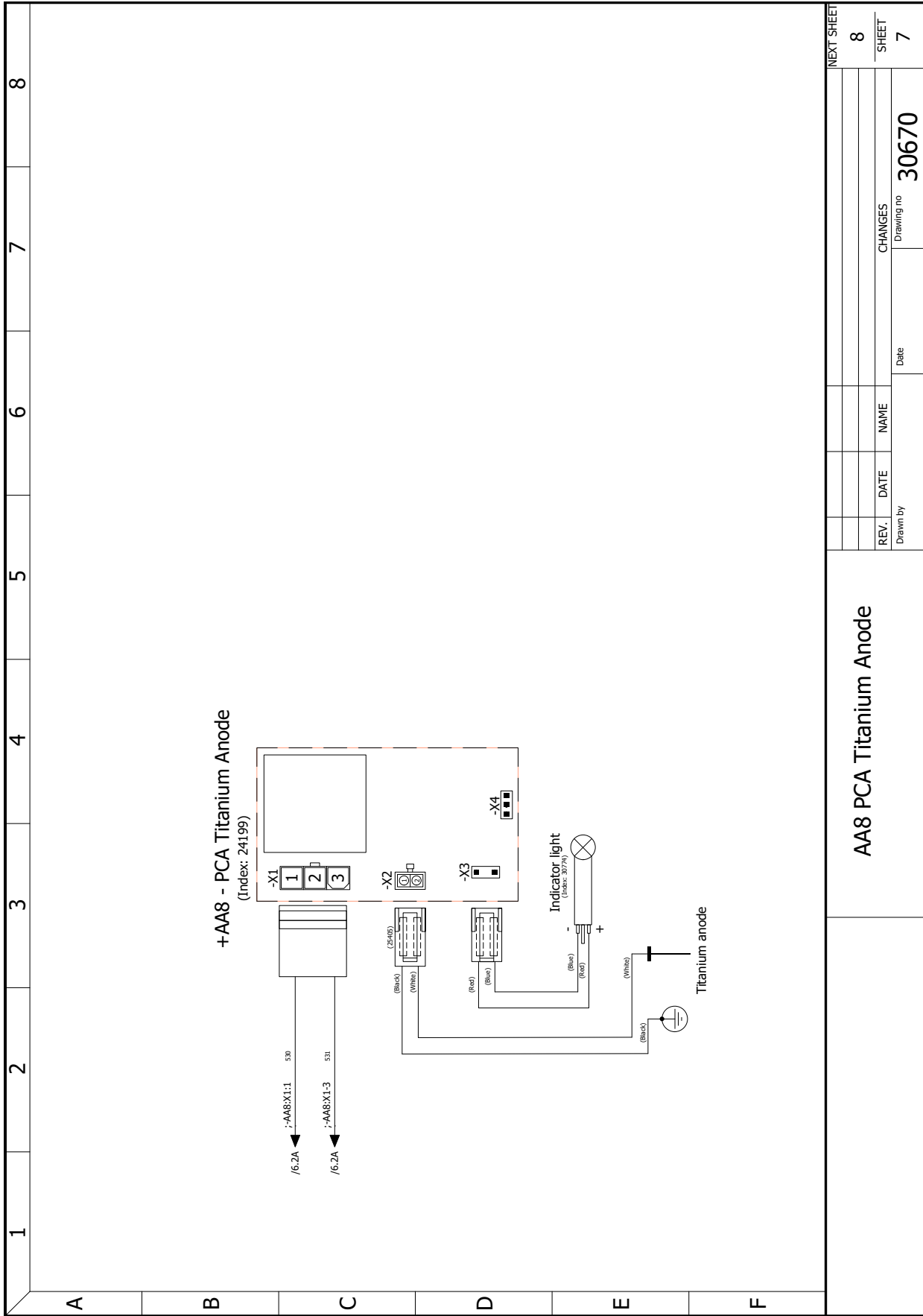

REV.	DATE	NAME	CHANGES
1			Drawing no
			Date
			30670

NEXT SHEET	
8	SHEET
7	SHEET

AA8 PCA Titanium Anode

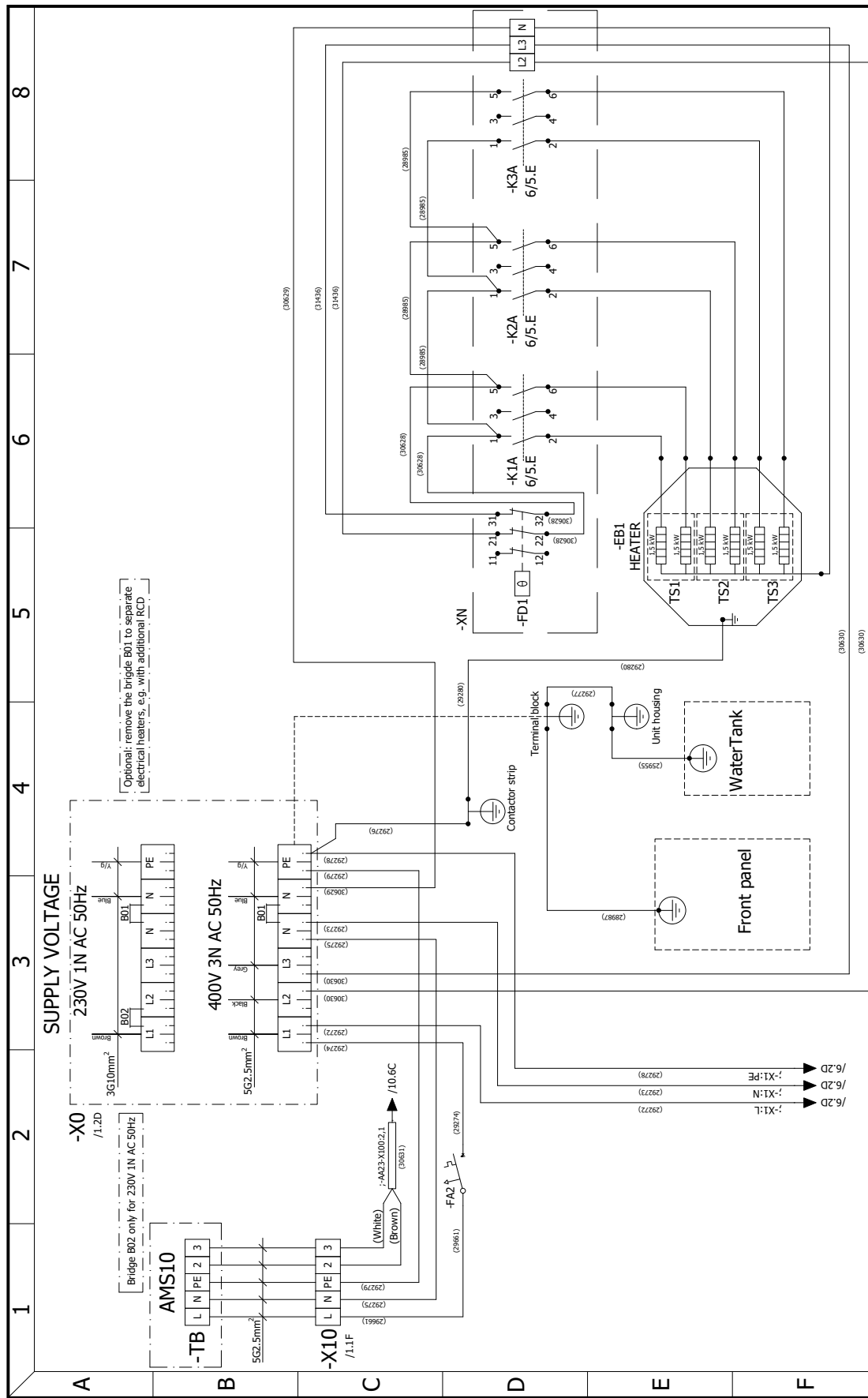

NEXT SHEET		9
SHEET		8
REV.	DATE	NAME
Drawn by		Date
CHANGES		Drawing no
		30670

Power connection

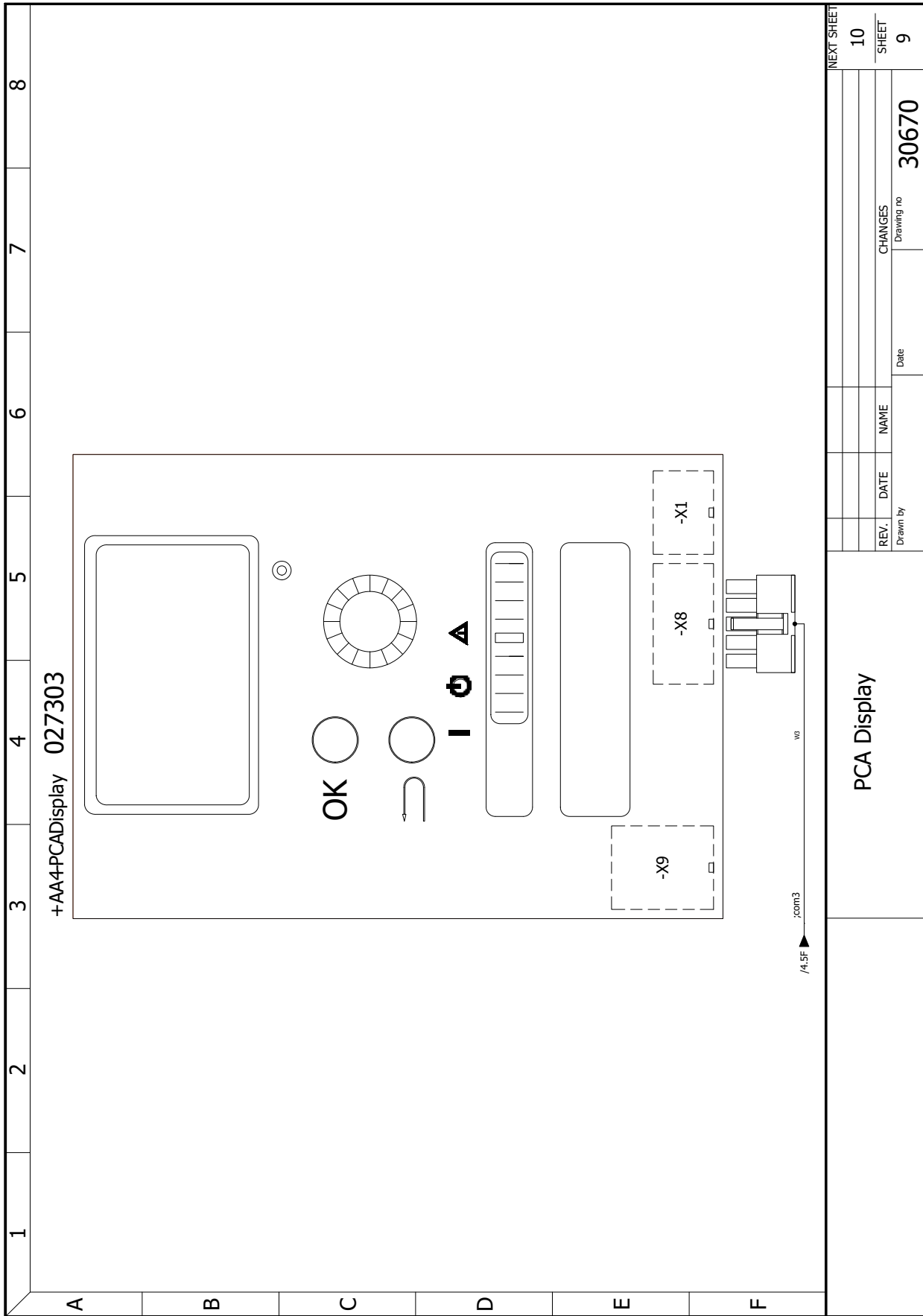

NEXT SHEET		10	SHEET		9
REV.	DATE	NAME	CHANGES	Drawing no	30670
Drawn by			Date		
PCA Display					

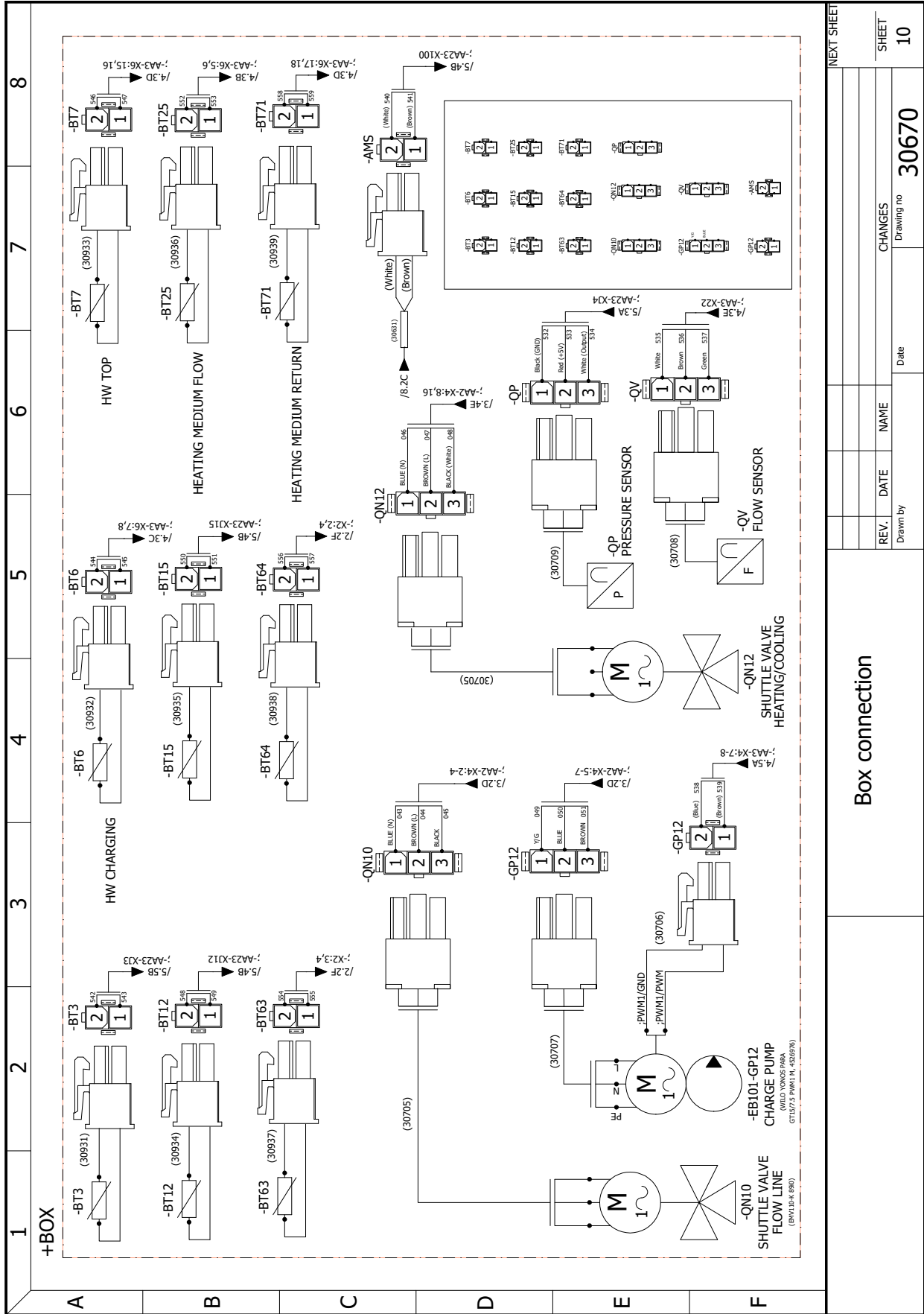

Box connection

REV.	DATE	NAME	Date

CHANGES	Drawing no
	30670



METRO THERM A/S
RUNDINSVEJ 55
DK3200 HELSINGE
INFO@METROTHERM.DK
WWW.METROTHERM.DK

08:242-1909