

# Data Sheet | Item Number: 253-111/000-006

2-conductor PCB terminal block; 1.5 mm<sup>2</sup>; Pin spacing 5 mm; 11-pole; PUSH WIRE®; blue

<https://www.wago.com/253-111/000-006>

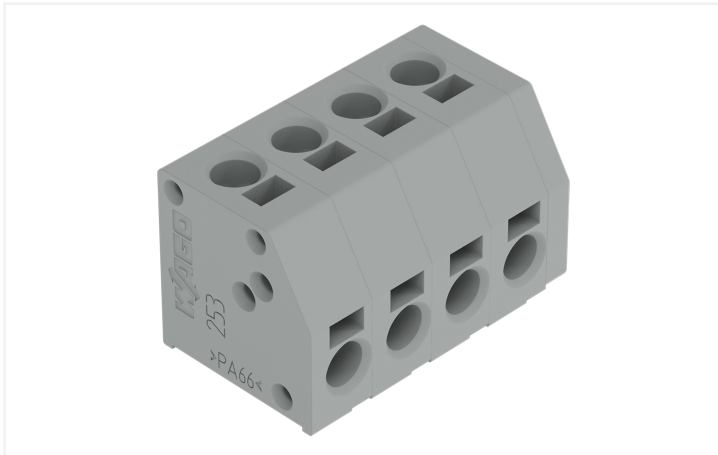

Color: ■ blue

Similar to illustration

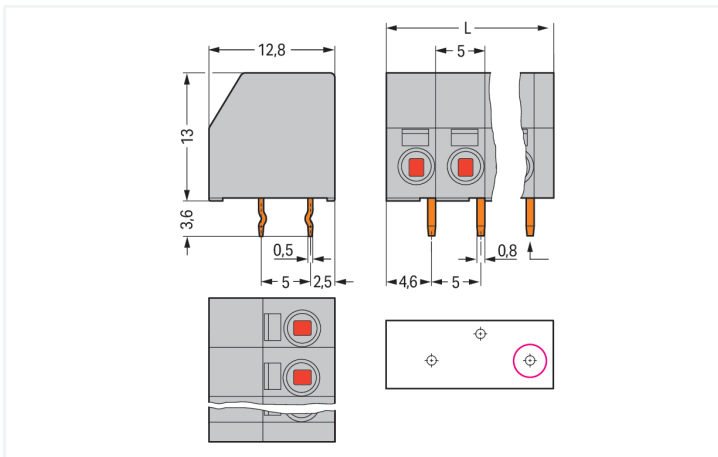
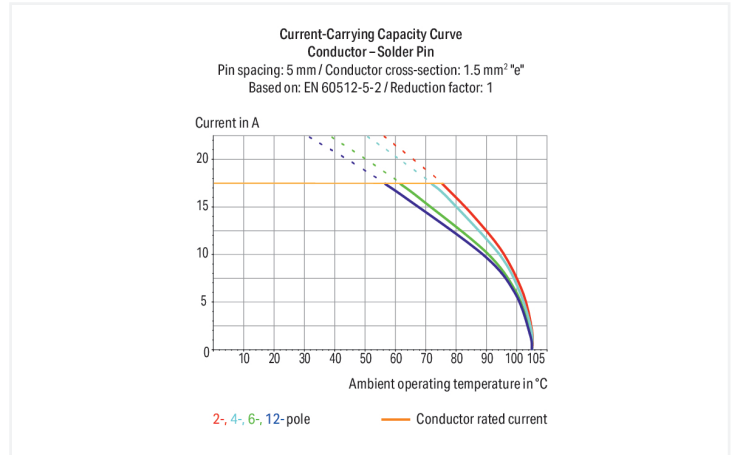

Dimensions in mm

L = (pole no. x pin spacing) + 2 mm First solder pin, front right (red circle)

PCB terminal block, 253 Series, solder pin dimensions 0.5 x 0.8 mm

Our PCB terminal block (item number 253-111/000-006) makes connections quick and easy. It offers the flexibility needed for different mounting types. Strip lengths must be between 8.5 and 9.5 mm when connecting conductors to this PCB terminal block. This product features two conductor terminals and utilizes PUSH WIRE® as well as PUSH WIRE®. Our PUSH WIRE® connection offers a quick and easy solution for connecting solid conductors. Dimensions: (57 x 16.6 x 12.8) mm (width x height x depth). This PCB terminal block is suitable for conductor cross sections ranging from 0.5 mm<sup>2</sup> to 1.5 mm<sup>2</sup> on one side and for conductor cross sections ranging from 0.5 mm<sup>2</sup> to 1.5 mm<sup>2</sup> on the other side.

Tin is used for coating the contact surfaces. This PCB terminal block is operated with an operating tool. THT is used to assemble the PCB terminal block. Insert the conductor into the board at an angle of 0°..

## Notes

Variants:	Other pole numbers Other colors Mixed-color PCB connector strips Direct marking Other versions (or variants) can be requested from WAGO Sales or configured at <a href="https://configurator.wago.com/">https://configurator.wago.com/</a> .
-----------	--

## Electrical data

Ratings per	IEC/EN 60664-1		
Overvoltage category	III	III	II
Pollution degree	3	2	2
Nominal voltage	320 V	320 V	630 V
Rated impulse withstand voltage	4 kV	4 kV	4 kV
Rated current	17.5 A	17.5 A	17.5 A

Approvals per	UL 1059		
Use group	B	C	D
Rated voltage	300 V	-	300 V
Rated current	8 A	-	5 A

Approvals per	CSA		
Use group	B	C	D
Rated voltage	300 V	-	300 V
Rated current	8 A	-	5 A

## Connection data

Clamping units	22
Total number of potentials	11
Number of connection types	2
Number of levels	1

## Connection 1

Connection type	PUSH WIRE® connection
Connection technology	PUSH WIRE®
Number of connection points	1
Actuation type	Operating tool
Solid conductor	0.5 ... 1.5 mm <sup>2</sup> / 20 ... 16 AWG
Strip length	8.5 ... 9.5 mm / 0.33 ... 0.37 inches
Note (strip length)	7 ... 8 mm / 0.28 ... 0.31 inch (for wiring on both sides)
Conductor connection direction to PCB	0°
Pole number	11

## Connection 2

Connection type	PUSH WIRE® connection
Connection technology	PUSH WIRE®
Number of connection points	1
Solid conductor	0.5 ... 1.5 mm <sup>2</sup> / 20 ... 16 AWG
Strip length	8.5 ... 9.5 mm / 0.33 ... 0.37 inches
Note (strip length)	7 ... 8 mm / 0.28 ... 0.31 inch (for wiring on both sides)
Conductor connection direction to PCB	90°

### Physical data

Pin spacing	5 mm / 0.197 inches
Width	57 mm / 2.244 inches
Height	16.6 mm / 0.654 inches
Height from the surface	13 mm / 0.512 inches
Depth	12.8 mm / 0.504 inches
Solder pin length	3.6 mm
Solder pin dimensions	0.5 x 0.8 mm
Drilled hole diameter with tolerance	1.1 <sup>(+0.1)</sup> mm

### PCB contact

PCB contact	THT
Solder pin arrangement	over the entire terminal strip (staggered)
Number of solder pins per potential	1

### Material data

Note (material data)	<a href="#">Information on material specifications can be found here</a>
Color	blue
Material group	I
Insulation material (main housing)	Polyamide (PA66)
Flammability class per UL94	V0
Clamping spring material	Chrome-nickel spring steel (CrNi)
Contact material	Electrolytic copper (E <sub>Cu</sub> )
Contact Plating	Tin
Fire load	0.197 MJ
Weight	9.5 g

### Environmental requirements

Limit temperature range	-60 ... +105 °C
-------------------------	-----------------

### Commercial data

Product Group	4 (Printed Circuit Connectors)
PU (SPU)	80 (20) pcs
Packaging type	Box
Country of origin	CN
GTIN	4017332649476
Customs tariff number	85369010000

### Product Classification

UNSPSC	39121409
eCl@ss 10.0	27-44-04-01
eCl@ss 9.0	27-44-04-01
ETIM 9.0	EC002643
ETIM 8.0	EC002643
ECCN	NO US CLASSIFICATION

**Environmental Product Compliance**

RoHS Compliance Status	Compliant, No Exemption
------------------------	-------------------------

**Approvals / Certificates**

**General approvals**



Approval	Standard	Certificate Name
cURus Underwriters Laboratories Inc.	UL 1059	E45172
UL UL International Germany GmbH	UL 1977	E45171

**Downloads**

**Environmental Product Compliance**

Compliance Search	
Environmental Product Compliance 253-111/000-006	<a href="#">↓</a>

**Documentation**

Additional Information			
Technical Section	03.04.2019	pdf 2027.26 KB	<a href="#">↓</a>

**CAD/CAE-Data**

CAD data	
2D/3D Models 253-111/000-006	<a href="#">↓</a>

CAE data	
EPLAN Data Portal 253-111/000-006	<a href="#">↓</a>
ZUKEN Portal 253-111/000-006	<a href="#">↓</a>

**PCB Design**

Symbol and Footprint via SamacSys 253-111/000-006	<a href="#">↓</a>
Symbol and Footprint via Ultra Librarian 253-111/000-006	<a href="#">↓</a>

## 1 Compatible Products

### 1.1 Optional Accessories

#### 1.1.1 Marking

##### 1.1.1.1 Marking strip



**Item No.: 210-833**

Marking strips; 25 m on roll; 6 mm wide; plain; Self-adhesive; white

**Item No.: 210-332/500-202**

Marking strips; as a DIN A4 sheet; MARKED; 1-16 (160x); Height of marker strip: 3 mm; Strip length 182 mm; Horizontal marking; Self-adhesive; white

**Item No.: 210-332/500-205**

Marking strips; as a DIN A4 sheet; MARKED; 1-32 (80x); Height of marker strip: 3 mm; Strip length 182 mm; Horizontal marking; Self-adhesive; white

**Item No.: 210-332/500-204**

Marking strips; as a DIN A4 sheet; MARKED; 17-32 (160x); Height of marker strip: 3 mm; Strip length 182 mm; Horizontal marking; Self-adhesive; white



**Item No.: 210-332/500-206**

Marking strips; as a DIN A4 sheet; MARKED; 33-48 (160x); Height of marker strip: 3 mm; Strip length 182 mm; Horizontal marking; Self-adhesive; white

### 1.1.2 Tool

#### 1.1.2.1 Operating tool



**Item No.: 210-719**

Operating tool; Blade: 2.5 x 0.4 mm; with a partially insulated shaft

**Item No.: 210-648**

Operating tool; Blade: 2.5 x 0.4 mm; with a partially insulated shaft; angled; short

**Item No.: 210-647**

Operating tool; Blade: 2.5 x 0.4 mm; with a partially insulated shaft; multicoloured

## Installation Notes

### Conductor termination

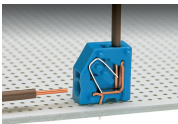

Inserting a conductor via push-in termination.

### Conductor removal

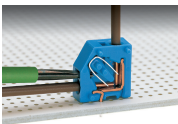

Removing a conductor via 2.5 mm screwdriver.

## Installation

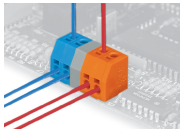

Mixed-color terminal strips (with or without spacer) are available upon request.