



Catalog | December 2013

Catalog 2013/2014

Electronic Products and Relays

Machine Safety

Jokab Safety products

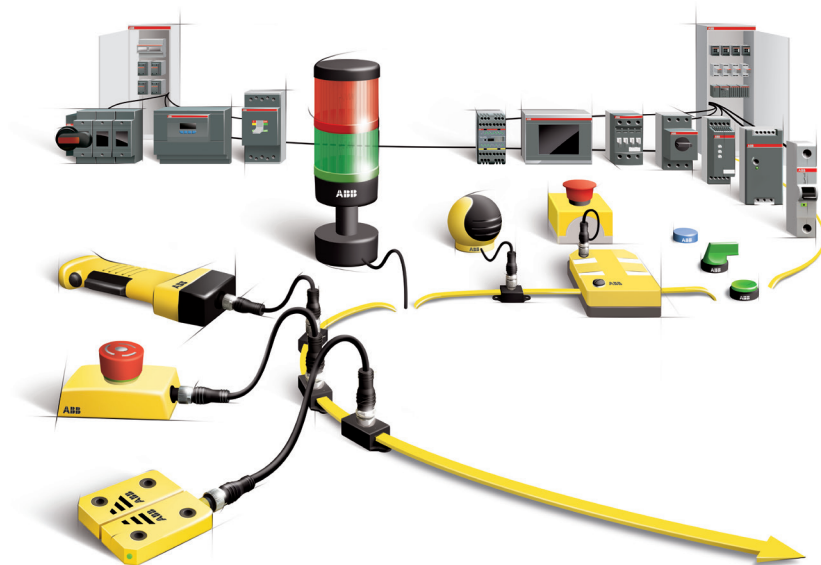

Productivity and safety go hand in hand

Jokab Safety was acquired by ABB in 2010. This gives us extra strength and a sales network in 120 countries. Our goal is to become even better at supporting you as a customer through cooperation within ABB Jokab Safety globally and locally. The fact that the leading power and automation technology company, ABB, and a leader in machine safety, Jokab Safety, have joined forces means a lot more than just a new organizational chart. ABB has a huge footprint in the industry - from power supply to the control of each individual motor - and has been delivering reliable solutions for decades that boost productivity in the industry. The acquisition of Jokab Safety means the last building block is in place. We can now offer our customers tailored, turnkey solutions where machine safety is an integral and value-enhancing component.

Jokab Safety offering:

- **Safety PLC**
Pluto, Pluto AS-i, Gateways, Safe Encoder
- **Safety controller**
Vital and Tina safety systems
- **Safety relays**
RT series, JSB series, safety timers, expansion relays
- **Light curtains, light grids, light beams and scanner**
Focus II, Spot, Look
- **Stop time measurement and machine diagnosis**
Smart
- **Sensors, switches and locks**
Eden, Sense, MKey, Magne, Dalton, Knox
- **Control devices**
JSHD4, Safeball, Fox2
- **Emergency stop devices**
Inca, Smile, EStrong, LineStrong
- **Contact rails, bumpers and safety mats**
- **Fencing systems**
Quick-Guard, SafeCad, Roller doors

Further information: „ABB Safety Handbook“ - Order code: 2TLC172001C0202

Electronic Products and Relays News



Electronic timers, measuring and monitoring relays for railway solutions

The requirements for rolling stock are increasing and will continue to do so. The task is to implement ever faster connections, while also increasing traveler comfort. During their everyday work, the trains are exposed to very high environmental, electrical and mechanical loads.

Selected products of the electronic timers and measuring and monitoring relays comply to the latest rail standards NF F 16-101/102, EN 45545, EN 50155 and more standards which are relevant for railway applications. Find more information in the rail brochure 2CDC110084B0201.

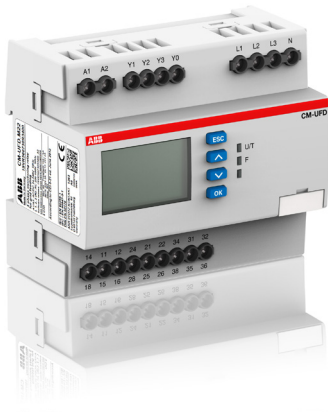

New range of grid feeding monitoring relays

The CM-UFx grid feeding monitoring relays can be used for measurement of voltage and frequency according to different standards:

- CM-UFD.M21: Grid feeding monitoring according to VDE AR-N 4105
- CM-UFD.M22: Grid feeding monitoring according to CEI 0-21
- CM-UFS.1: Grid feeding monitoring according to DIN V VDE V 0126-1-1: Feb. 2006

The device is connected between the decentral electrical energy source (e.g. photovoltaic systems, wind turbines, block-type thermal power stations) and the public grid. In case the public grid is disconnected due to any reason, for instance during maintenance work, the CM-UFx recognizes this powerless situation. Then, in conjunction with a section switch, the CM-UFx disconnects the decentral electrical energy source from the public grid, shows the corresponding alarm on the display and signals the cause of alarm to a superior control system.



CM-IWx range - Monitoring of insulation resistance in unearthed AC/DC systems

The field of applications for insulation monitors is quite big, it covers machines and generators, emergency power supplies and ship applications, railway applications and mobile power generators (air planes), industrial IT systems, printing applications and the renewable energy segments, like wind and photo voltaic. With the CM-IWx range ABB offer a modular and adjustable assortment of insulation monitors. An insulation monitor constantly detects the insulation resistance to earth and releases a signal whenever the thresholds are passed.

Characteristics:

- Six devices cover the whole range of necessary maximum system leakage capacitances for grid feeding applications
- Easy to handle front-face operating controls with status indication via LEDs
- Direct connection to 690 V AC / 1000 V DC systems possible in combination with coupling unit CM-IVN



CP-ASI range - Primary switch mode power supply for AS-interfaces

The CP-ASI power supply range is specifically designed with integrated data decoupling for the supply of AS-Interface systems. Up to 62 slaves (binary I/O devices) can be supplied with a single two-conductor cable. The configurable IR addressing mode allows the easy assign of new ID addresses by means of an external infrared programming unit.

Electronic Products and Relays

Table of contents

Electronic timers	1/1	1
Measuring and monitoring relays	2/1	2
Primary switch mode power supplies	3/1	3
Analog signal converters, serial data converters	4/1	4
Interface relays and optocouplers	5/1	5
Panel heaters	6/1	6
Logic relays	7/1	7
Index	8/1	8

Approvals and marks for the world market





Overview

ABB low-voltage switching devices are developed and produced in accordance with the applicable regulations as stated in the international IEC publications, the European EN specifications and the national VDE standards.

In most countries, low-voltage switching devices are produced according to such regulations under the responsibility of the manufacturers. This is why the devices are not subject to further approval. However, for those devices which are intended for use in household or for public use our customers can request test reports of our internal laboratory for presentation to the various qualified local organizations. In other countries, approvals are prescribed by law.

For devices installed in ships, an approval issued by independent shipping companies, such as the GL, are demanded by the maritime insurance companies.

Marks of conformity and examples of approvals (device-dependent)

<p>International</p> <p>CB scheme </p> <p>The CB (Certification Body) Scheme is a system designed to facilitate international trade by establishing mutual acceptance of test reports among participating safety certification organizations (the National Certification Bodies) in more than 30 countries. The CB Scheme was established by the International Electrotechnical Committee for Conformity Testing to Standards for Electrical Equipment (IECEE).</p>	<p>Berufsgenossenschaft der Feinmechanik und Elektrotechnik (BGFE) </p> <p>The BG-PRÜFZERT sign is a voluntary safety mark, awarded by the BGFE following successful safety testing.</p> <p>Explosion protection (EX) </p> <p>Explosion protection acc. to Directive 94/9/EG (ATEX 100a)</p>	<p>China</p> <p>CCC (China Compulsory Certification) </p> <p>In China the CCC certification mark is a compulsory certification mark in the field of safety and quality for products sold on the Chinese market.</p>
<p>Europe</p> <p>Conformité Européen (CE) </p> <p>All devices which comply with the European low voltage directive and which are intended for sale within the European Union must have the CE sign applied. All products in this catalog are CE marked.</p>	<p>Swiss insurance institution (SUVA) </p> <p>Department accident prevention suvaPRO</p> <p>Germanischer Lloyd (GL) </p> <p>Shipping approval</p> <p>Lloyds Register </p> <p>Shipping approval</p>	<p>North America</p> <p>Canadian and US standards are more or less equivalent but considerably differ from the IEC and VDE regulations.</p> <p>USA</p> <p>Underwriters Laboratories (UL) Listing </p> <p>Released for installation in systems and for sale as individual component in the USA.</p>
<p>The CE sign must not be confused with a certificate of quality issued by the EU. It is solely used to confirm that the respective product complies with the applicable European directives^{*)}. The CE sign is part of an administrative procedure to guarantee free movement of goods within the European Community.</p> <p>*) Directives: Low Voltage Directive 2006/95/EC EMC Directive 2004/108/EC Machinery Directive 98/37/EEC</p>	<p>Russia</p> <p>In Russia, low-voltage switching devices are subject to certification and have to be provided with a sign.</p> <p>Gost Standard (GOST-R)¹⁾ </p> <p>Gost R certification is mandatory for many products. This certification is based on a safety test (IEC standards with Russia-specific deviations) and an EMC test.</p>	<p>Recognition </p> <p>Released for installation in systems, if the respective system has been completely mounted and wired by qualified personnel.</p>
<p>Verband der Elektrotechnik Elektronik Informationstechnik (VDE) </p> <p>Applicable for technical instruments covered by the German Gerätesicherheitsgesetz (GSG) as well as for single parts and electrical wiring devices.</p>	<p>Russian Maritime Register of Shipping RMRS </p> <p>Shipping approval</p> <p>Australia, New Zealand</p> <p>C-Tick Mark </p> <p>The C-Tick Mark certifies compliance with the Australian EMC requirements. The Mark is also recognized in New Zealand.</p>	<p>Canada</p> <p>Canadian Standards Association (CSA) </p> <p>USA and Canada</p> <p>The combined UL signs for the USA and Canada are recognized by the authorities of both countries. Devices with this certificate meet the requirements of both countries.</p> <p>Listing </p> <p>Recognition </p>

¹⁾ May have been replaced by EAC during the availability of this catalog edition.

Documentation in ABB Library

www.abb.com/lowvoltage

When you enter www.abb.com/lowvoltage for the first time, you will be asked to select your country and to select your preferred language (see screen shot 1). You can change this setting later if you like.



Search

Products & Services only

+ Rate this page

+ Share this page

Your preferences:

United States of America

English

Select Control Products to find Electronic Products and Relays in world wide web.

Low Voltage Products and Systems

Products and systems that provide protection, control and measurement for electrical installations, enclosures, switchboards, electronics and electromechanical devices for industrial machines, plants and related service. The offering also includes intelligent building control systems, also known as KNX systems, for home and building automation to improve comfort, energy efficiency and security.



Take control of your productivity



AF contactor range
The new standard in motor control and power switching. Connect to Control!

SACE Emax 2
The evolution from circuit-breaker to power manager

Our offering

- **Cable Distribution Cabinets**
Cable distribution cabinets, busbar systems and terminal clamps
- **Circuit Breakers**
Air Circuit Breakers, Moulded Case Circuit Breakers, Miniature Circuit Breakers, Manual Motor Starters, monitoring System and Service.
- **Control Products**
Arc Guard Systems, Contactors, Manual Motor Starters, Pilot Devices, Electronic Relays and Controls, Safety products and more.
- **Door Entry Systems**
- **Enclosures**
Main Distribution Boards, Multi Purpose Boxes, Sub Distribution Boards, Consumer Units, Installation Enclosures, Meter Boards, Special Enclosures, Control and Automation Boards, Cable Management Systems
- **Industrial Plugs and Sockets**
- **Capacitors and Filters**
- **Connection Devices**
Entrelec terminals. SNK and 5000 series
- **Design Software**
- **Enclosed Switches**
Enclosed safety switches, switch-disconnectors, switch fuses, cam switches, accessories and service
- **Fusegear**
Switch fuses, fuse switch disconnectors, fuse bases, fuse links and fuse monitors
- **Intelligent Building Systems**
- **Modular DIN Rail Products**
Miniature Circuit Breakers, Residual Current Breakers, Protection and safety, Command and signaling, Control and automation, Instruments, Measuring devices
- **Switches**

The whole EPR assortment is splitted in four different categories:

- Electronic Relays and Controls
- Motor Controllers
- Power Supplies
- Signal Converters

Click on depending category for further documentation e.g. **Electronic Relays and Controls**















Control Products

Our program is already among the most extensive in the market and we are constantly adding new products in order to meet ever changing customer needs.

Quality and reliability are built into every device to ensure total performance satisfaction, even in the most demanding applications.

We offer a very modern and competitive range of contactors, softstarters, starters, limit switches, manual motor starters, a wide range of electronic relays and overload relays, together with an extended program of pilot devices, PLCs and wireless devices.

Our offering

<div style="border: 1px solid #ccc; padding: 5px; margin-bottom: 5px;">  <p>→ Arc Guard Systems Arc Monitor, builds on the well known TVOC design</p> </div> <div style="border: 1px solid #ccc; padding: 5px; margin-bottom: 5px;">  <p>→ Contactors Bar Mounted Contactors, Electronic Overload Relays, Mini Contactors, Block Contactors, Installation Contactors, Thermal Overload Relays</p> </div> <div style="border: 1px solid #ccc; padding: 5px; margin-bottom: 5px;">  <p>→ Fieldbus Devices CANopen FieldBusPlugs, Fieldbus Device Accessories, Profibus DP FieldBusPlugs, DeviceNet FieldBusPlugs, MODBUS FieldBusPlugs</p> </div> <div style="border: 2px solid red; padding: 5px; margin-bottom: 5px;">  <p>→ Motor Controllers Universal Motor Controller Accessories and Motor Controllers as UMC100-FBP and UMC22-FBP</p> </div> <div style="border: 1px solid #ccc; padding: 5px; margin-bottom: 5px;">  <p>→ Pilot Devices Operator and Pilot Lights, Signaling Devices and Operator and Pilot Lights Accessories</p> </div> <div style="border: 1px solid #ccc; padding: 5px; margin-bottom: 5px;">  <p>→ Programmable Logic Controllers PLCs AC500-eCo PLC, S500-eCo I/O Module, CP400 Operator Panel and many more</p> </div> <div style="border: 1px solid #ccc; padding: 5px;">  <p>→ Sensors Current Sensors, Limit Switches, Current Transducers and Voltage Sensors</p> </div>	<div style="border: 1px solid #ccc; padding: 5px; margin-bottom: 5px;">  <p>→ Contactor Starters Mini reversing contactors VB6, VB7 and VB6A, VB7A</p> </div> <div style="border: 2px solid red; padding: 5px; margin-bottom: 5px;">  <p>→ Electronic Relays and Controls Electronic Timers, Measuring and Monitoring Relays (Single and Three Phase), Insulation Monitors, Interface Relays and Optocouplers, Thermistor Motor Protection, Temperature Monitors, Panel Heaters and many more</p> </div> <div style="border: 1px solid #ccc; padding: 5px; margin-bottom: 5px;">  <p>→ Manual Motor Starters Manual Motor Starters</p> </div> <div style="border: 1px solid #ccc; padding: 5px; margin-bottom: 5px;">  <p>→ Operator Panels Control Panel Accessories, Control Panels and Control Panel Software</p> </div> <div style="border: 2px solid red; padding: 5px; margin-bottom: 5px;">  <p>→ Power Supplies The CP range offers newest technology in a compact construction of power supplies</p> </div> <div style="border: 1px solid #ccc; padding: 5px; margin-bottom: 5px;">  <p>→ Safety Products Products and solutions for Machine Safety. Safety PLCs, Safety Relays, Light Barriers, Safety Sensors, Control Devices, Fencing Systems and many more.</p> </div> <div style="border: 2px solid red; padding: 5px;">  <p>→ Signal Converters Analog Signal Converters and Serial Data Converters</p> </div>
---	---

After selecting e.g. Electronic Relays and Controls it is possible to select the product range of interest directly. Please select one of the product ranges as listed below, e.g. **Time Relays**.

Our offering

<p>→ Contact Protection Relays</p> <p>→ Interface Relays and Optocouplers</p> <p>→ Liquid Level Monitors and Controls</p> <p>→ Motor Load Monitors</p> <p>→ Sensor Interface Relays</p> <p>→ Temperature Monitors</p> <p>→ Three Phase Monitors</p>	<p>→ Cycle Monitors</p> <p>→ Isolation Monitors</p> <p>→ Logic Relays</p> <p>→ Safety Relays</p> <p>→ Single Phase Monitors</p> <p>→ Thermistor Motor Protection Relays</p> <p>→ Time Relays</p>
--	---

Documentation in ABB Library

www.abb.com/lowvoltage

For each product range the **Overview**-tab describes the specific product offering. It is possible to jump directly to technical data or to the download section. Here an example for time relays:

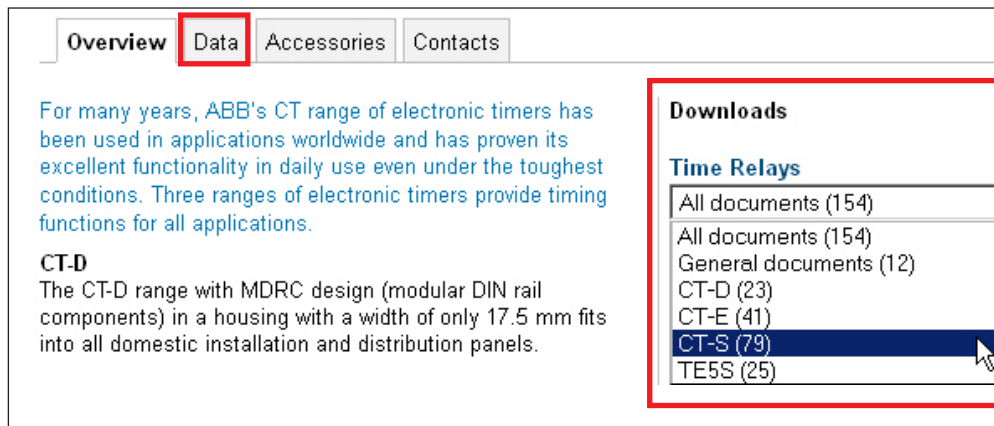

The screenshot shows a product page with four tabs: Overview, Data, Accessories, and Contacts. The 'Data' tab is selected and highlighted with a red box. Below the tabs, there is a paragraph of text describing the CT range of electronic timers. Below this text, there is a section titled 'CT-D' with a description. To the right of the main content, there is a 'Downloads' section with a dropdown menu titled 'Time Relays'. The dropdown menu is open, showing a list of document categories: All documents (154), General documents (12), CT-D (23), CT-E (41), CT-S (79), and TE5S (25). The 'CT-S (79)' option is highlighted with a blue bar and a mouse cursor is pointing at it.

Overview **Data** Accessories Contacts

For many years, ABB's CT range of electronic timers has been used in applications worldwide and has proven its excellent functionality in daily use even under the toughest conditions. Three ranges of electronic timers provide timing functions for all applications.

CT-D
The CT-D range with MDRC design (modular DIN rail components) in a housing with a width of only 17.5 mm fits into all domestic installation and distribution panels.

Downloads

Time Relays

- All documents (154)
- All documents (154)
- General documents (12)
- CT-D (23)
- CT-E (41)
- CT-S (79)**
- TE5S (25)

Downloads: By using the drop down list you can filter the list of available information according to the entry of the drop down list e.g. CT-S. You can find a short tutorial of the **Download section** on page 10.

Data: The data tab shows a list of search results of the product range. Additionally you can filter the results by using the filters on the right section of the data tab. Like that you can find the specific products which corresponds to your specific demands. You can find a short tutorial of the **Data Tab** section on page 11.

Documentation in ABB Library

Download section

In the download section, select an entry of the drop down list to filter the available downloads e.g. CT-S.

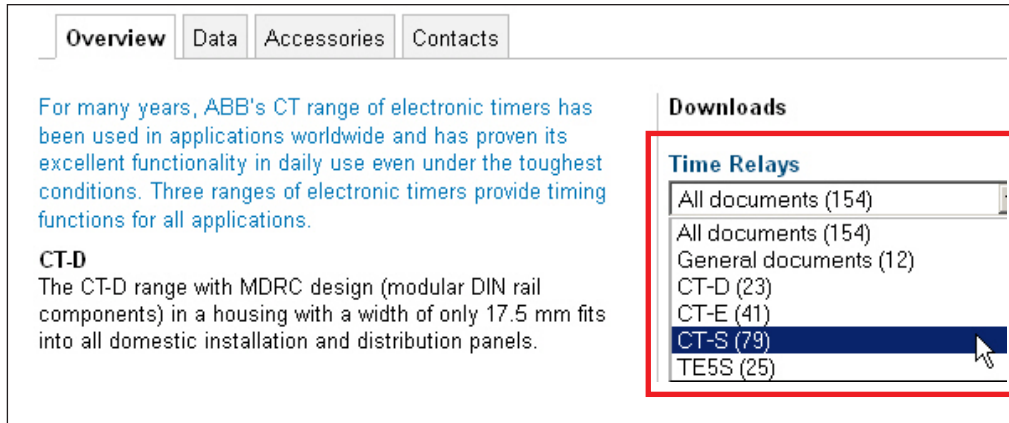

The screenshot shows a web interface with tabs for 'Overview', 'Data', 'Accessories', and 'Contacts'. The 'Overview' tab is active. Below the tabs, there is a paragraph of text about ABB's CT range of electronic timers. To the right, there is a 'Downloads' section with a dropdown menu titled 'Time Relays'. The dropdown menu is open, showing a list of categories: 'All documents (154)', 'General documents (12)', 'CT-D (23)', 'CT-E (41)', 'CT-S (79)', and 'TE5S (25)'. The 'CT-S (79)' option is highlighted in blue, and a mouse cursor is pointing at it.

The list of available downloads is filtered according to the selection.



The screenshot shows a list of document types with expandable icons (+) and counts in parentheses: 'Brochure (2)', 'Catalogue (2)', 'Certificate (13)', 'Data sheet (40)', 'Declaration of conformity (6)', 'Information (1)', 'Instruction (6)', 'Photo (30)', and 'Press release (2)'. Below the list is an 'Expand all' link. To the right, there is a '+' icon, the ABB logo, and the text 'Kingd', 'Sales:', 'Service', and a 'Select' button.

Expand one of the nodes, e.g. brochure.

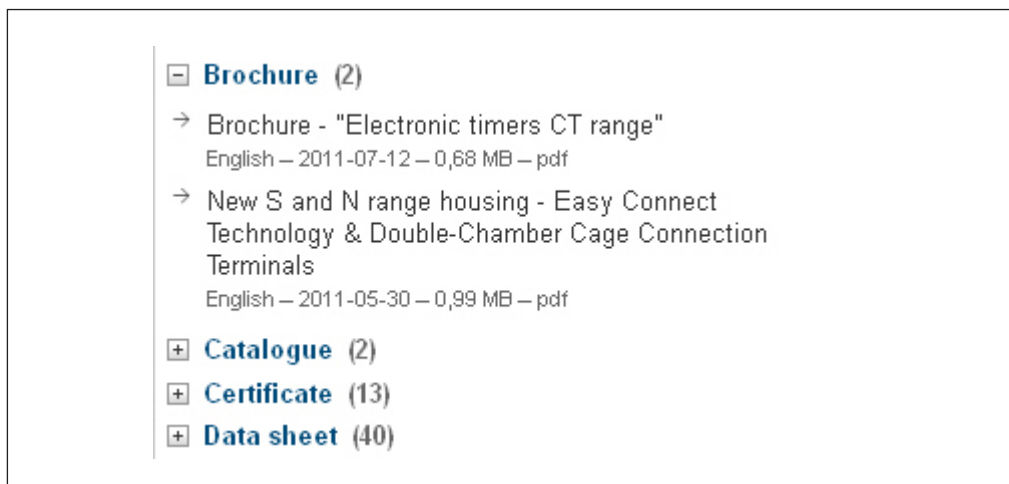

The screenshot shows the 'Brochure (2)' node expanded. It contains two entries: 'Brochure - "Electronic timers CT range"' (English - 2011-07-12 - 0,68 MB - pdf) and 'New S and N range housing - Easy Connect Technology & Double-Chamber Cage Connection Terminals' (English - 2011-05-30 - 0,99 MB - pdf). Below the expanded node, the other document types are still visible with their expandable icons (+): 'Catalogue (2)', 'Certificate (13)', and 'Data sheet (40)'.

Click on the document which you would like to display.
The document will open.

Documentation in ABB Library

Data Tab

Click on the tab **Data** to enter to the Data Tab of the product range (in this case Time Relays).

Overview **Data** Accessories Contacts

For many years, ABB's CT range of electronic timers has been used in applications worldwide and has proven its excellent functionality in daily use even under the toughest conditions. Three ranges of electronic timers provide timing functions for all applications.

CT-D

Downloads

Time Relays

CT-S (79)

Popular documents

Time Relays

Overview **Data** Accessories Contacts

Search Results (149 Results) **Sort By:** Product

More Search Options

Filters Add/Remove.. Clear

Click on name to select values

Timer Relay Type
Time Range
Rated Control Supply Voltage
Output
Terminal Type
Product Main Type
Extended Product Type

Product	Information	Show 10 items
CT-AHD.12 1SVR500110R0000	CT-AHD.12 Time relay, OFF-delay	
CT-AHD.22 1SVR500110R0100	CT-AHD.22 Time relay, OFF-delay	
CT-AHE	CT-AHE Time relay, OFF-delay	

Use the filters on the right section of the page to customize the list of products displayed, e.g. **Time Range**.

Time Relays

Overview **Data** Accessories Contacts

Search Results (149 Results) **Sort By:** Product

More Search Options

Filters Add/Remove.. Clear

Click on name to select values

Timer Relay Type
Time Range
Rated Control Supply Voltage
Output
Terminal Type
Product Main Type
Extended Product Type

Product	Information	Show 10 items
CT-AHD.12 1SVR500110R0000	CT-AHD.12 Time relay, OFF-delay	
CT-AHD.22 1SVR500110R0100	CT-AHD.22 Time relay, OFF-delay	
CT-AHE 1SVR500111R2100	CT-AHE Time relay, OFF-delay	
CT-AHE	CT-AHE Time relay, OFF-delay	

Documentation in ABB Library Data Tab

A window is opened. Here you can add or remove a value of the filter you have chosen (in our example Time Range). On the left side just click on the value you want to add. Then click on the **Add**-button. The value appears on the right side. After adding the value just click on **Apply** to set the filter for the search results.

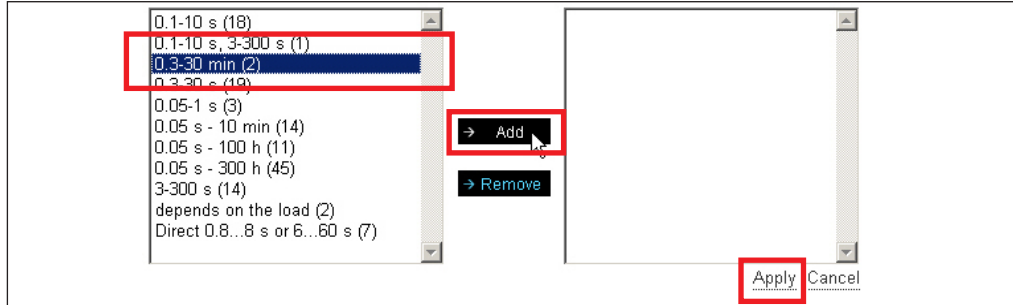

After clicking on **Apply** the search results are now shown with the defined filter.

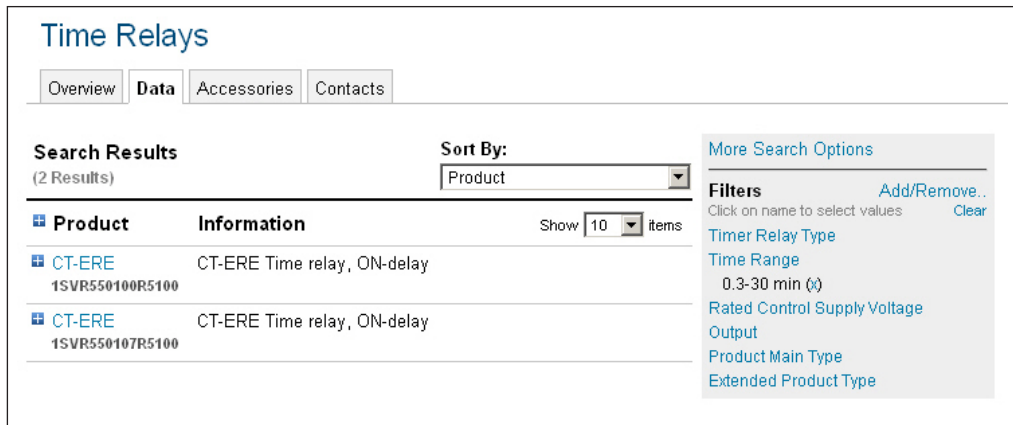

Selecting a specific product opens the detailed information sheet, e.g. CT-ERE 1SVR550100R5100.

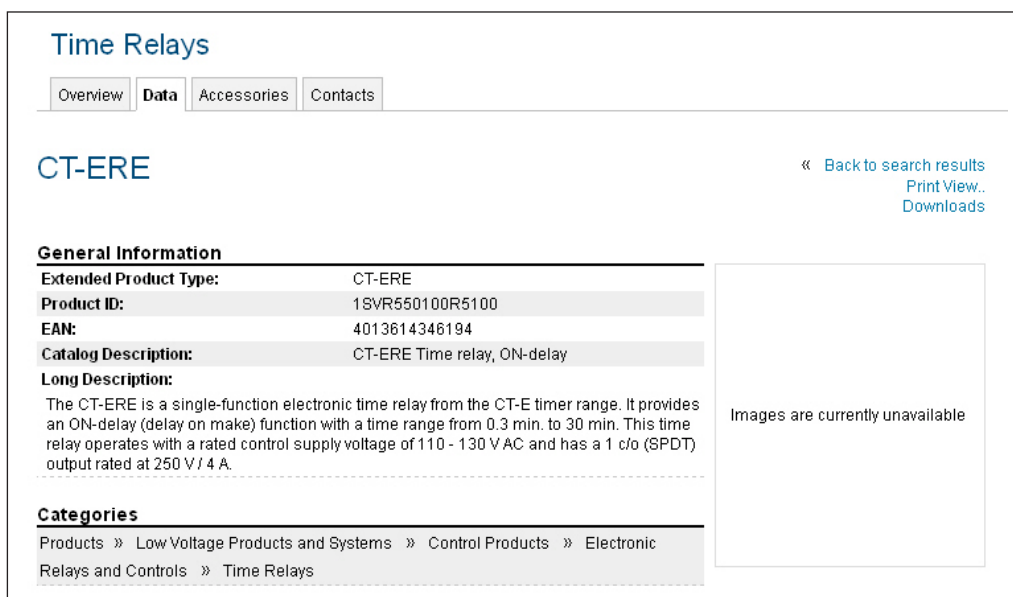

On the bottom of the page you can find further documentation and download information.

Electronic timers

Product group picture

1



Electronic timers

Table of contents

Electronic timers	
Table of contents	1/2
Overview	1/3
Approvals and marks	1/4
CT-D range	1/5
Table of contents	1/6
Benefits and advantages	1/7
Ordering details	1/8
Function diagrams	1/9
Connection diagrams	1/12
Technical data	1/13
Technical data, Technical diagrams	1/15
Wiring notes, Dimensional drawings	1/16
CT-E range	1/17
Table of contents	1/18
Benefits and advantages	1/19
Ordering details	1/20
Function diagrams	1/22
Connection diagrams	1/27
Connection diagrams, Technical diagrams	1/28
Technical data	1/29
Wiring notes, Dimensional drawings	1/31
CT-S range	1/33
Table of contents	1/34
Benefits and advantages	1/35
Ordering details - multifunctional	1/37
Ordering details - singlefunctional	1/38
Ordering details - Accessories	1/39
Function diagrams	1/41
Connection diagrams	1/49
Technical data	1/52
Technical diagrams	1/55
Wiring notes, Dimensional drawings	1/56

Electronic timers

Overview

1



CT-D range

CT-E range

CT-S range

Timing function	multifunctional	single-functional	multifunctional	single-functional	multifunctional	single-functional
ON-delay	CT-MFD	CT-ERD	CT-MFE, CT-MKE	CT-ERE, CT-EKE	CT-MVS, CT-MFS, CT-MBS, CT-WBS	CT-ERS
OFF-delay	CT-MFD	CT-AHD	CT-MFE	CT-AHE, CT-ARE, CT-AKE	CT-MVS, CT-MFS, CT-MBS	CT-APS, CT-AHS, CT-ARS, CT-VBS
ON- and OFF-delay					CT-MVS, CT-MXS, CT-MFS, CT-MBS	
Impulse-ON	CT-MFD	CT-VWD	CT-MFE, CT-MKE	CT-VWE	CT-MVS, CT-MFS, CT-MBS, CT-WBS	
Impulse-OFF	CT-MFD			CT-AWE	CT-MVS, CT-MFS, CT-MBS	
Impulse-ON and OFF					CT-MXS	
Flasher starting with ON	CT-MFD	CT-EBD	CT-MFE, CT-MKE		CT-MFS, CT-MBS, CT-WBS	
Flasher starting with OFF	CT-MFD		CT-MFE, CT-MKE	CT-EBE	CT-MFS, CT-MBS, CT-WBS	
Flasher starting with ON or OFF					CT-MVS	
Pulse generator starting with ON or OFF		CT-TGD			CT-MXS	
Pulse former	CT-MFD		CT-MFE		CT-MVS, CT-MFS, CT-MBS	
Star-delta change-over		CT-SDD, CT-SAD				CT-SDS
Star-delta change-over with impulse				CT-SDE	CT-MVS.2x, CT-MFS, CT-MBS	
Star-delta change-over twice ON-delayed				CT-YDE		
further functions (depending on device)					CT-MVS, CT-MXS, CT-MFS, CT-MBS, CT-WBS	
Switching relay				CT-IRE		CT-IRS
Technical data (extract)						
Time ranges	7 (0.05 s - 100 h) CT-SDD, CT-SAD: 4 (0.05 s - 10 min)		Multifunction devices: 8 (0.05 s - 100 h) Single-function devices: 5 single ranges (0.05-1 s, 0.1-10 s, 0.3-30 s, 3-300 s, 0.3-300 min)		10 (0.05 s - 300 h) CT-ARS, CT-SDS: 7 (0.05 s- 10 min)	
Control supply voltage	Wide and multi ranges		Wide ranges	Single and dual ranges	Wide, multi and single ranges	
Type and number of contacts	1 or 2 c/o contacts CT-SDD, CT-SAD: 2 n/o contacts		1 c/o contact CT-SDE: 1 n/o contact and 1 n/c contact CT-MKE, CT-EKE, CT-AKE: 1 thyristor		1 or 2 c/o contacts CT-MVS.21, CT-MFS, CT-MBS: 2nd c/o contact selectable as inst. contact CT-SDS: 2 n/o contacts	
Control inputs	voltage-related triggering, polarized, capable of switching a parallel load		voltage-related triggering, polarized CT-MFE, CT-AHE, CT-AWE: with auxiliary voltage		voltage-related triggering, non-polarized, capable of switching a parallel load CT-MFS, CT-MBS, CT-AHS: volt-free triggering	

Electronic timers

Approvals and marks

		CT-D																	
		CT-MFD.12	CT-MFD.21	CT-ERD.12	CT-ERD.22	CT-AHD.12	CT-AHD.22	CT-VWD.12	CT-EBD.12	CT-TGD.12	CT-TGD.22	CT-SDD.22	CT-SAD.22						
Approvals																			
	UL 508, CAN/CSA C22.2 No. 14	■	■	■	■	■	■	■	■	■	■	■	■						
	CB scheme	■	■	■	■	■	■	■	■	■	■	■	■						
	EAC	□	□	□	□	□	□	□	□	□	□	□	□						
	CCC	■	■	■	■	■	■	■	■	■	■	■	■						
	RMRS	■	■	■	■	■	■	■	■	■	■	■	■						
Marks																			
	CE	■	■	■	■	■	■	■	■	■	■	■	■						
	C-Tick	■	□	■	□	■	□	■	■	■	□	□	□						

		CT-E																	
		CT-MFE	CT-ERE	CT-AHE	CT-ARE	CT-VWE	CT-AWE	CT-EBE	CT-YDE	CT-SDE	CT-IRE		CT-MKE	CT-EKE	CT-AKE				
Approvals																			
	UL 508, CAN/CSA C22.2 No. 14	■	■	■	■	■	■	■	■	■	■	■	■	■	■	■			
	GL	■	■	■	■	■	■	■	■	■	■	■	■	■	■	■			
	CB scheme	■	■	■	■	■	■	■	■	■	■	■	■	■	■	■			
	EAC	□	□	□	□	□	□	□	□	□	□	□	□	□	□	□			
	CCC	■	■	■	■	■	■	■	■	■	■	■	■	■	■	■			
	RMRS	■	■	■	■	■	■	■	■	■	■	■	■	■	■	■			
Marks																			
	CE	■	■	■	■	■	■	■	■	■	■	■	■	■	■	■			
	C-Tick	■	■	■	■	■	■	■	■	■	■	■	■	■	■	■			

		CT-S																		
		CT-MVS.12S/P	CT-MVS.2xS/P	CT-MXS.22S/P	CT-MFS.21S/P	CT-MBS.22S/P	CT-WBS.22S/P	CT-ERS.12S/P	CT-ERS.2xS/P	CT-APS.12S/P	CT-APS.2xS/P	CT-AHS.22S/P	CT-ARS.11S/P	CT-ARS.21S/P	CT-VBS.1x	CT-SDS.2xS/P		CT-HRS.1x	CT-HRS.2x	CT-HRS.3x
Approvals																				
	UL 508, CAN/CSA C22.2 No. 14	■	■	■	■	■	■	■	■	■	■	■	■	■	■	■	■			
	GL	■	■	■	■	■	■	■	■	■	■	■	□	□	■	■	■			
	EAC	□	□	□	□	□	□	□	□	□	□	□	□	□	□	□	□			
	CB scheme	■	■	■	■	■	■	■	■	■	■	■	■	■	■	■	■	■	■	■
	CCC	■	■	■	■	■	■	■	■	■	■	■	■	■	■	■	■	■	■	■
	RMRS	■	■	■	■	■	■	■	■	■	■	■	■	■	■	■	■	■	■	■
	Rail applications ¹⁾		■	■	■				■		■		■	■	■	■		■	■	■
Marks																				
	CE	■	■	■	■	■	■	■	■	■	■	■	■	■	■	■	■	■	■	■
	C-Tick	■	■	■	■	■	■	■	■	■	■	■	■	■	■	■	■	■	■	■

¹⁾ Applicable in rail application following the latest standards for rail applications. Further information are available in our rail segment brochure 2CDC110084B0201.

CT-D range Product group picture

1



CT-D range

Table of contents

CT-D Range	
Product group picture	1/5
Table of contents	1/6
Benefits and advantages	1/7
Ordering details	1/8
Function diagrams	1/9
Connection diagrams	1/12
Technical data	1/13
Technical data, Technical diagrams	1/15
Wiring notes, Dimensional drawings	1/16

CT-D range

Benefits and advantages

1

Characteristics

- Diversity:
 - 2 multifunction timers
 - 10 single-function timers
- Control supply voltages:
 - Wide range: 12-240 V AC/DC
 - Multi range: 24-48 V DC, 24-240 V AC
- 7 time ranges from 0.05 s to 100 h or 4 time ranges from 0.05 s to 10 min
- Width of only 17.5 mm
- Light-grey housing in RAL 7035
- Devices with:
 - 1 c/o contact (250 V / 6 A) or 2 c/o contacts (250 V / 5 A)
 - Control input: voltage-related triggering, polarized, capable of switching parallel loads
- Approvals / Marks (partly pending, details see page 1/4)



Benefits

Direct reading scales ①

Direct setting of the time delay without any additional calculation provides accurate time delay adjustment.

LEDs for status indication ②

All actual operational states are displayed by front-face LEDs, thus simplifying commissioning and troubleshooting.

Switching currents

The CT-D range timers allow an output load of up to 6 A on devices with 1 c/o contact and up to 5 A on devices with 2 c/o contacts.

Connection terminals ③

Wide terminal spacing allows connection of wires: 2 x 1.5 mm² (2 x 16 AWG) with wire end ferrules or 2 x 2.5 mm² (2 x 14 AWG) without ferrules.

Width 17,5 mm ④

With their width of 17.5 mm only, the CT-D range timers are ideally suited for installation in distribution panels.

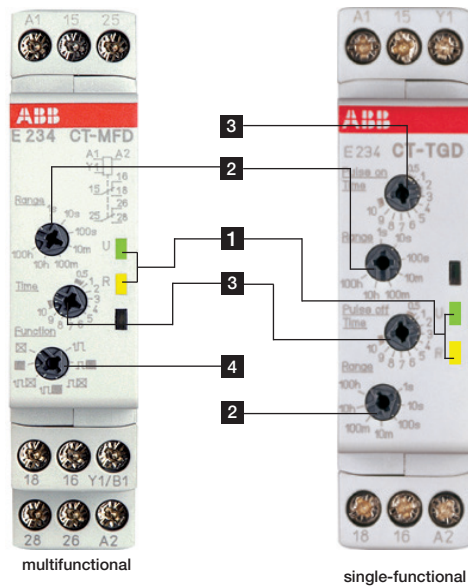

Operating controls

- 1 LEDs for status indication
 - U - green LED:
 - control supply voltage applied
 - timing
 - R, R1, R2 - yellow LED:
 - output relay energized
- 2 Time range adjustment
- 3 Fine adjustment of the time delay
- 4 Preselection of the timing function

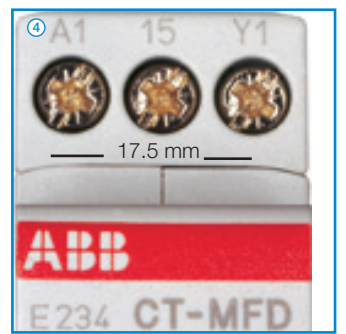
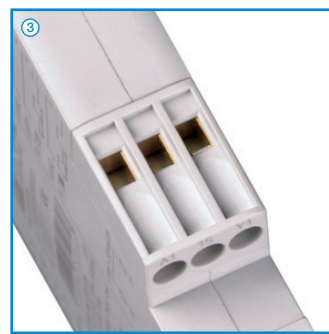
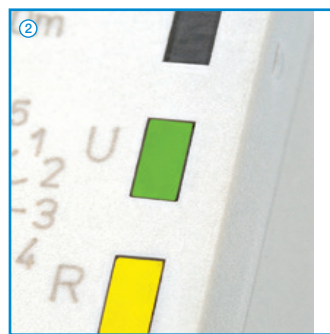

CT-D range

Ordering details

Description

The CT-D range in MDRC design with a width of only 17.5 mm fits into all domestic installation and distribution panels.

The CT-D range represents a link between industry and the installation types. For maximum flexibility in operation, 10 single-function as well as 2 multifunction devices with 7 timing functions are available. The devices offer 4 or 7 time ranges from 0.05 seconds up to 100 hours. Their wide input range allows the use in applications worldwide..

Ordering details

Timing function	Rated control supply voltage	Time ranges	Control input	Output	Type	Order code	Price	Weight (1 pce)
							1 pce	kg (lb)
Multifunctional ¹⁾	24-240 V AC 24-48 V DC	7 (0.05 s - 100 h)	■	1 c/o	CT-MFD.12	1SVR500020R0000		0.060 (0.132)
Multifunctional ¹⁾	12-240 V AC/DC	7 (0.05 s - 100 h)	■	2 c/o	CT-MFD.21	1SVR500020R1100		0.065 (0.143)
ON-delay			-	1 c/o	CT-ERD.12	1SVR500100R0000		0.060 (0.132)
			-	1 c/o	CT-ERD.22	1SVR500100R0100		0.065 (0.143)
OFF-delay		7 (0.05 s - 100 h)	■	1 c/o	CT-AHD.12	1SVR500110R0000		0.060 (0.132)
			■	2 c/o	CT-AHD.22	1SVR500110R0100		0.065 (0.143)
Impulse-ON	24-240 V AC 24-48 V DC		-		CT-VWD.12	1SVR500130R0000		0.060 (0.132)
Flasher starting with ON			-	1 c/o	CT-EBD.12	1SVR500150R0000		0.060 (0.132)
Pulse generator		2x7 (0.05 s - 100 h)	■		CT-TGD.12 ²⁾	1SVR500160R0000		0.060 (0.132)
			■	2 c/o	CT-TGD.22 ²⁾	1SVR500160R0100		0.065 (0.143)
Star-delta change-over		4 (0.05 s - 10 min)	-		CT-SDD.22 ³⁾	1SVR500211R0100		0.065 (0.143)
			-	2 c/o	CT-SAD.22 ⁴⁾	1SVR500210R0100		0.065 (0.143)



CT-MFD.12



CT-ERD.22

¹⁾ Functions: ON-delay, OFF-delay with auxiliary voltage, Impulse-ON, Impulse-OFF with auxiliary voltage, Flasher starting with ON, Flasher starting with OFF, Pulse former

²⁾ ON and OFF times adjustable independently: 2 x 7 time ranges 0.05 s - 100 h

³⁾ Transition time 50 ms fixed

⁴⁾ Transition time adjustable

■ Control input with voltage-related triggering
- no triggering

- ☒ ON-delay
- OFF-delay
- 1☒ Impulse-ON
- 1☒ Impulse-OFF
- ☒ Flasher starting with ON
- ☒ Flasher starting with OFF
- ☒ Pulse former
- ☒ Pulse generator
- △ Star-delta change-over

Synonyms

used expression	alternative expression(s)	used expression	alternative expression(s)
1 c/o contact	SPDT	voltage-related	wet / non-floating
2 c/o contacts	DPDT	volt-free	dry / floating

CT-D range

Function diagrams

1 Remarks

Legend

- Control supply voltage not applied / Output contact open
- Control supply voltage applied / Output contact closed
- A1-Y1/B1 Control input with voltage-related triggering

Terminal designations on the device and in the diagrams

- The 1st c/o contact is always designated **15-16/18**.
- The 2nd c/o contact is designated **25-26/28**.
- The n/o contacts of the star-delta timers are designated with **17-18** and **17-28**.
- Control supply voltage is always applied to terminals **A1-A2**.

Function of the yellow LED

The yellow LED **R** glows as soon as the output relay energizes and turns off when the output relay de-energizes.

☒ ON-delay (Delay on make) CT-ERD, CT-MFD

This function requires continuous control supply voltage for timing. Timing begins when control supply voltage is applied. The green LED flashes during timing. When the selected time delay is complete, the output relay energizes and the flashing green LED turns steady. If control supply voltage is interrupted, the output relay de-energizes and the time delay is reset. Control input **A1-Y1/B1** of the CT-MFD is disabled when this function is selected.

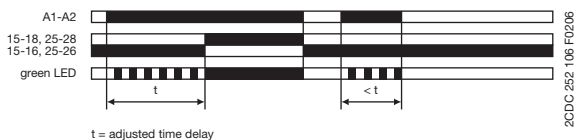

■ OFF-delay with auxiliary voltage (Delay on break) CT-AHD, CT-MFD

This function requires continuous control supply voltage for timing. If control input **A1-Y1/B1** is closed, the output relay energizes immediately. If control input **A1-Y1/B1** is opened, the time delay starts. The green LED flashes during timing. When the selected time delay is complete, the output relay de-energizes and the flashing green LED turns steady. If control input **A1-Y1/B1** recloses before the time delay is complete, the time delay is reset and the output relay does not change state. Timing starts again when control input **A1-Y1/B1** re-opens. If control supply voltage is interrupted, the output relay de-energizes and the time delay is reset.

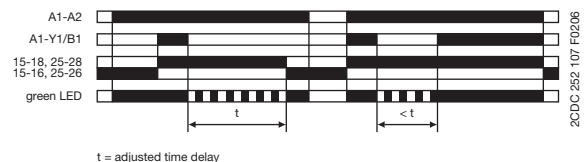

1☒ Impulse-ON (Interval) CT-VWD, CT-MFD

This function requires continuous control supply voltage for timing. The output relay energizes immediately when control supply voltage is applied and de-energizes after the set pulse time is complete. The green LED flashes during timing. When the selected pulse time is complete, the flashing green LED turns steady. If control supply voltage is interrupted, the output relay de-energizes and the time delay is reset. Control input **A1-Y1/B1** of the CT-MFD is disabled when this function is selected.

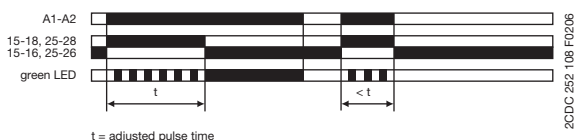

1☒ Impulse-OFF with auxiliary voltage (Trailing edge interval) CT-MFD

This function requires continuous control supply voltage for timing. If control supply voltage is applied, opening control input **A1-Y1/B1** energizes the output relay immediately and starts timing. The green LED flashes during timing. When the selected pulse time is complete, the output relay de-energizes and the flashing green LED turns steady. Closing control input **A1-Y1/B1**, before the time delay is complete, de-energizes the output relay and resets the time delay. If control supply voltage is interrupted, the output relay de-energizes and the time delay is reset.

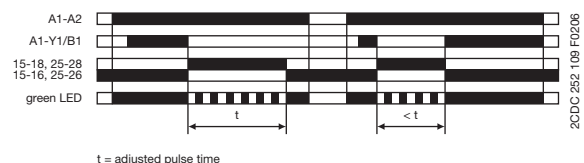

CT-D range

Function diagrams

Flasher, starting with the ON time (Recycling equal times, ON first) CT-EBD, CT-MFD

Applying control supply voltage starts timing with symmetrical ON & OFF times. The cycle starts with an ON time first. The ON & OFF times are displayed by the flashing green LED, which flashes twice as fast during the OFF time.

If control supply voltage is interrupted, the output relay de-energizes and the time delay is reset.

Control input **A1-Y1/B1** of the CT-MFD is disabled when this function is selected.

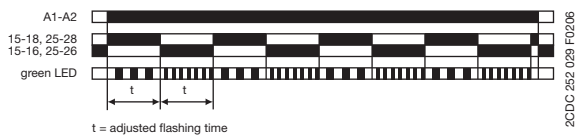

Flasher, starting with the OFF time (Recycling equal times, OFF first) CT-MFD

Applying control supply voltage starts timing with symmetrical ON & OFF times. The cycle starts with an OFF time first. The ON & OFF times are displayed by the flashing green LED, which flashes twice as fast during the OFF time.

If control supply voltage is interrupted, the output relay de-energizes and the time delay is reset.

Control input **A1-Y1/B1** of the CT-MFD is disabled when this function is selected.

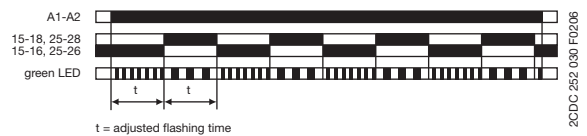

Pulse former (Single shot) CT-MFD

This function requires continuous control supply voltage for timing.

Closing control input **A1-Y1/B1** energizes the output relay immediately and starts timing. Operating the control contact switch **A1-Y1/B1** during the time delay has no effect. The green LED flashes during timing. When the selected ON time is complete, the output relay de-energizes and the flashing green LED turns steady. After the ON time is complete, it can be restarted by closing control input **A1-Y1/B1**.

If control supply voltage is interrupted, the output relay de-energizes and the time delay is reset.

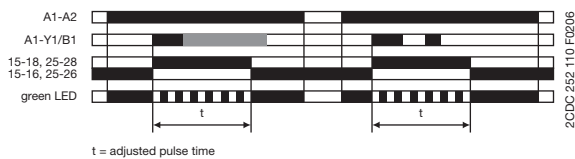

Pulse generator, starting with the ON or OFF time (Recycling unequal times, ON or OFF first) CT-TGD

This function requires continuous control supply voltage for timing.

Applying control supply voltage, with open control input **A1-Y1/B1**, starts timing with an ON time first. Applying control supply voltage, with closed control input **A1-Y1/B1**, starts timing with an OFF time first. The ON & OFF times are displayed by the flashing green LED, which flashes twice as fast during the OFF time.

The ON & OFF times are independently adjustable.

If control supply voltage is interrupted, the output relay de-energizes and the time delay is reset.

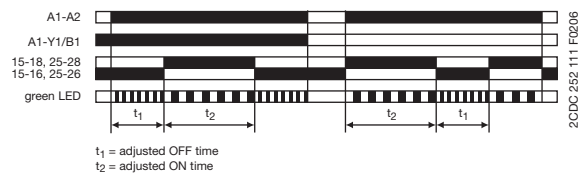

CT-D range

Function diagrams

1 Δ Star-delta change-over (Star-delta starting) CT-SDD, CT-SAD

This function requires continuous control supply voltage for timing. Applying control supply voltage to terminals **A1-A2**, energizes the star contactor connected to terminals **17-18** and begins the set starting time t_1 . The green LED flashes during timing. When the starting time is complete, the first output contact de-energizes the star contactor. Now, the transition time t_2 starts. When the transition time is complete, the second output contact energizes the delta contactor connected to terminals **17-28**. The delta contactor remains energized as long as control supply voltage is applied to the unit.

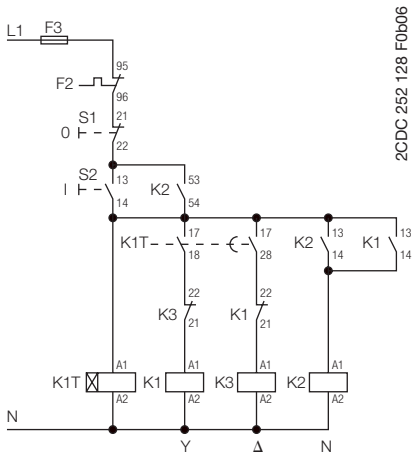
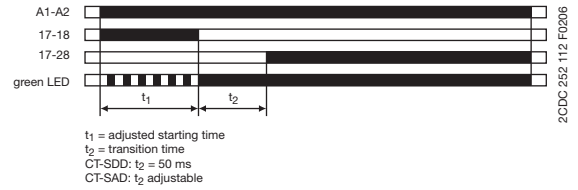

Control circuit diagram

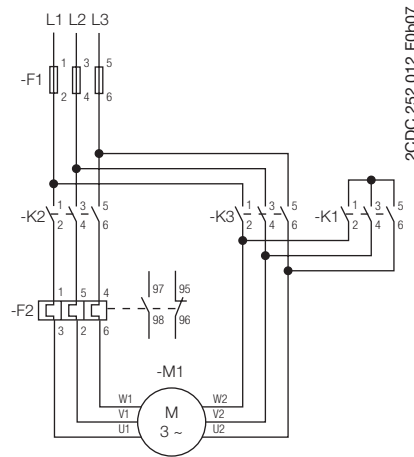

Power circuit diagram

CT-D range

Connection diagrams

CT-MFD.21

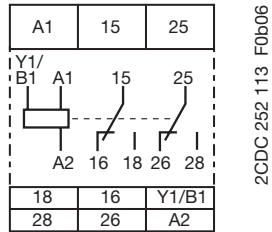

2CDC 252 113 F0b06

A1-A2 Supply: 12-240 V AC/DC

15-16/18 1. c/o contact
25-26/28 2. c/o contact
A1-Y1/B1 Control input

CT-MFD.12

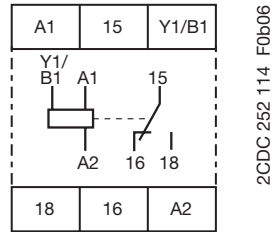

2CDC 252 114 F0b06

A1-A2 Supply: 24-48 V DC or 24-240 V AC

15-16/18 1. c/o contact
A1-Y1/B1 Control input

CT-ERD.22

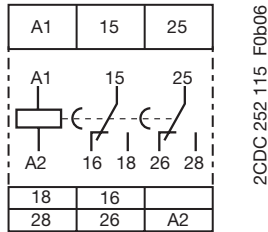

2CDC 252 115 F0b06

A1-A2 Supply: 24-48 V DC or 24-240 V AC

15-16/18 1. c/o contact
25-26/28 2. c/o contact

CT-ERD.12

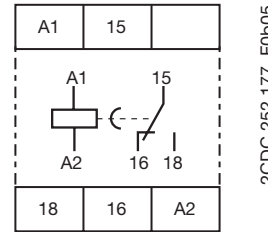

2CDC 252 177 F0b05

A1-A2 Supply: 24-48 V DC or 24-240 V AC

15-16/18 1. c/o contact

CT-AHD.22

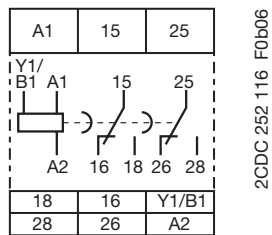

2CDC 252 116 F0b06

A1-A2 Supply: 24-48 V DC or 24-240 V AC

15-16/18 1. c/o contact
25-26/28 2. c/o contact
A1-Y1/B1 Control input

CT-AHD.12

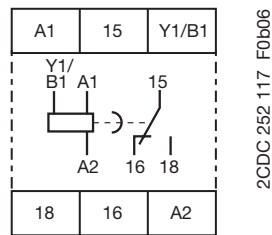

2CDC 252 117 F0b06

A1-A2 Supply: 24-48 V DC or 24-240 V AC

15-16/18 1. c/o contact
A1-Y1/B1 Control input

CT-VWD.12

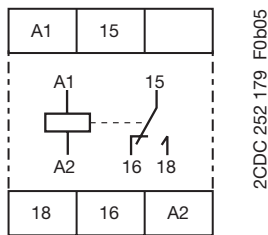

2CDC 252 179 F0b05

A1-A2 Supply: 24-48 V DC or 24-240 V AC

15-16/18 1. c/o contact

CT-EBD.12

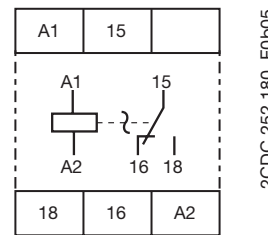

2CDC 252 180 F0b05

A1-A2 Supply: 24-48 V DC or 24-240 V AC

15-16/18 1. c/o contact

CT-TGD.22

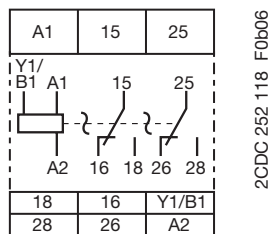

2CDC 252 118 F0b06

A1-A2 Supply: 24-48 V DC or 24-240 V AC

15-16/18 1. c/o contact
25-26/28 2. c/o contact
A1-Y1/B1 Control input

CT-TGD.12

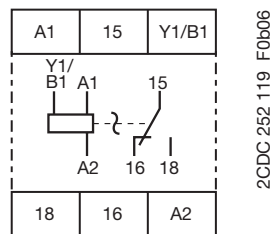

2CDC 252 119 F0b06

A1-A2 Supply: 24-48 V DC or 24-240 V AC

15-16/18 1. c/o contact
A1-Y1/B1 Control input

CT-SDD.22

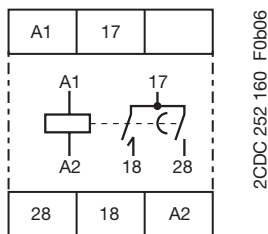

2CDC 252 160 F0b06

A1-A2 Supply: 24-48 V DC or 24-240 V AC

17-18 1. n/o contact (star contactor)
17-28 2. n/o contact (delta contactor)

CT-SAD.22

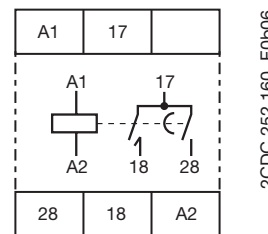

2CDC 252 160 F0b06

A1-A2 Supply: 24-48 V DC or 24-240 V AC



17-18 1. n/o contact (star contactor)
17-28 2. n/o contact (delta contactor)

CT-D range

Technical data

1

Data at $T_a = 25\text{ °C}$ and rated values, unless otherwise indicated

	CT-D with 1 c/o contact	CT-D with 2 c/o contacts	CT-MFD.21
Input circuit - Supply circuit			
Rated control supply voltage U _c	24-240 V AC / 24-48 V DC		12-240 V AC/DC
Rated control supply voltage U _c tolerance	-15...+10 %		
Rated frequency	AC/DC versions AC versions	DC or 50/60 Hz 50/60 Hz	
Frequency range	DC or 47-63 Hz		
Typical current / power consumption	see data sheet		
Power failure buffering time	min. 20 ms	min. 30 ms	
Input circuit - Control circuit			
Kind of triggering	voltage-related triggering		
Control input, Control function	A1-Y1/B1	start timing external	
Parallel load / polarized	yes / yes		
Maximum cable length to the control inputs	50 m - 100 pF/m		
Minimum control pulse length	30 ms		
Control voltage potential	see rated control supply voltage		
Current consumption of the control input	max. 4 mA	see data sheet	
Timing circuit			
Time ranges	7 time ranges 0.05 s - 100 h	1.) 0.05-1 s 2.) 0.5-10 s 3.) 5-100 s 4.) 0.5-10 min 5.) 5-100 min 6.) 0.5-10 h 7.) 5-100 h	
	4 time ranges 0.05 s - 10 min (CT-SDD, CT-SAD)	1.) 0.05-1 s 2.) 0.5-10 s 3.) 5-100 s 4.) 0.5-10 min	
Recovery time	< 50 ms		
Accuracy within the rated control supply voltage tolerance	$\Delta t < 0.005\%$ / V		
Accuracy within the temperature range	$\Delta t < 0.06\%$ / °C		
Repeat accuracy (constant parameters)	$\Delta t < \pm 0.5\%$		
Star-delta transition time	CT-SDD / CT-SAD	fixed 50 ms / adjustable: 20-100 ms in steps of 10 ms	
Star-delta transition time tolerance	CT-SDD / CT-SAD	±3 ms	
Indication of operational states			
Control supply voltage / timing	U: green LED	 : control supply voltage applied  : timing	
Relay status	R: yellow LED	 : output relay energized	
Output circuit			
Kind of output	15-16/18 15-16/18; 25-26/28 17-18; 17-28	Relay, 1 c/o contact - relay, 2 n/o contacts (CT-SDD, CT-SAD)	- Relay, 2 c/o contacts
Contact material	Cd-free, see data sheet		
Rated operational voltage U _c	IEC/EN 60947-1	250 V	
Minimum switching voltage / minimum switching current	12 V / 100 mA		
Maximum switching voltage / maximum switching current	see load limit curves		
Rated operational current I _c (IEC/EN 60947-5-1)	AC12 (resistive) at 230 V AC15 (inductive) at 230 V DC12 (resistive) at 24 V DC13 (inductive) at 24 V	6 A 3 A 6 A 2 A	5 A 3 A 5 A 2 A ¹⁾
AC rating (UL 508)	Utilization category Rating Code max. rated operational voltage	B 300 300 V AC	
	Maximum continuous thermal current at B300 max. making/breaking apparent power at B300	5 A 3600 VA / 360 VA	
AC rating (UL 508) only n/c contact (CT-MFD.21)	Utilization category Rating Code max. rated operational voltage	C 300 300 V AC	
	Maximum continuous thermal current at C300 max. making/breaking apparent power at C300	2.5 A 1800 VA / 180 VA	
Mechanical lifetime	30 x 10 ⁶ switching cycles		
Electrical lifetime	0.1 x 10 ⁶ switching cycles		
Max. fuse rating to achieve short-circuit protection (IEC/EN 60947-5-1)	n/c contact n/o contact	6 A fast-acting 10 A fast-acting	6 A fast-acting
General data			
Duty time	100%		
Dimensions (W x H x D)	17.5 x 70 x 58 mm (0.69 x 2.76 x 2.28 in)	17.5 x 80 x 58 mm (0.69 x 3.15 x 2.28 in)	
Weight	see ordering details		
Mounting	DIN rail (IEC/EN 60715), snap-mounting without any tool		
Mounting position	any		
Minimum distance to other units	horizontal / vertical	no / no	
Degree of protection	housing / terminals	IP50 / IP20	

CT-D range

Technical data

	CT-D with 1 c/o contact	CT-D with 2 c/o contacts	CT-MFD.21
Electrical connection			
Wire size	fine-strand with(out) wire end ferrule	2 x 0.5-1.5 mm ² (2 x 20-16 AWG) 1 x 0.5-2.5 mm ² (1 x 20-14 AWG)	
	rigid	2 x 0.5-1.5 mm ² (2 x 20-16 AWG) 1 x 0.5-4 mm ² (1 x 20-12 AWG)	
Stripping length		7 mm (0.28 in)	
Tightening torque		0.5-0.8 Nm (4.43-7.08 lb.in)	
Environmental data			
Ambient temperature range	operation / storage	-20 ... +60 °C / -40 ... +85 °C	
Damp heat (cyclic)	IEC/EN 60068-2-30	6 x 24 h cycles, 55 °C, 95 % RH	
Vibration (sinusoidal)	IEC/EN 60068-2-6	40 m/s ² , 20 cycles, 10...150...10 Hz	
Shock (half-sine)	IEC/EN 60068-2-27	100 m/s ² , 11 ms	
Isolation data			
Rated impulse withstand voltage U _{imp} between all isolated circuits	VDE 0110, IEC/EN 60664-1	4 kV; 1.2/50 µs	
Pollution category	IEC/EN 60664-1, VDE 0110	3	
Overvoltage category	IEC/EN 60664-1, VDE 0110	III	
Rated insulation voltage U _i	input circuit / output circuit	300 V	
	output circuit 1 / output circuit 2	300 V	
Basic insulation (IEC/EN 61140)	input circuit / output circuit	300 V	
Protective separation (VDE 0106 part 101 and part 101/A1; IEC/EN 61140)	input circuit / output circuit	250 V	
Power-frequency withstand voltage test (test voltage, routine test)	between all isolated circuits	2.5 kV, 50 Hz, 1 s	
Standards			
Product standard		IEC 61812-1, EN 61812-1 + A11, DIN VDE 0435 part 2021	
Low Voltage Directive		2006/95/EC	
EMC Directive		2004/108/EC	
RoHS Directive		2002/95/EC	
Electromagnetic compatibility			
Interference immunity to		IEC/EN 61000-6-1, IEC/EN 61000-6-2	
electrostatic discharge	IEC/EN 61000-4-2	Level 3 (6 kV / 8 kV)	
radiated, radio-frequency, electromagnetic field	IEC/EN 61000-4-3	Level 3 (10 V / m)	
electrical fast transient / burst	IEC/EN 61000-4-4	Level 3 (2 kV / 5 kHz)	
surge	IEC/EN 61000-4-5	Level 4 (2 kV L-L)	
conducted disturbances, induced by radio-frequency fields	IEC/EN 61000-4-6	Level 3 (10 V)	
Interference emission		IEC/EN 61000-6-3, IEC/EN 61000-6-4	
high-frequency radiated	IEC/CISPR 22, EN 55022	Class B	
high-frequency conducted	IEC/CISPR 22, EN 55022	Class B	

„Approvals and marks“ see page 1/4.

CT-D range

Technical data, Technical diagrams

1

Technical diagrams

Load limit curves

AC load (resistive)

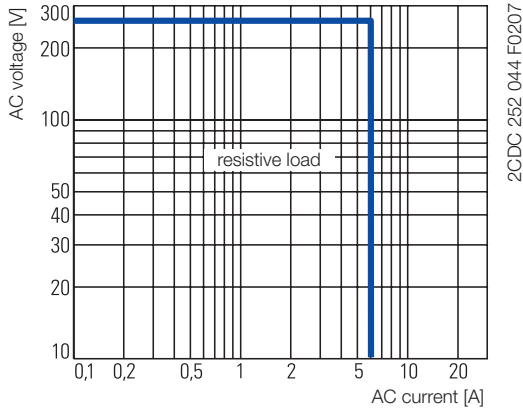

CT-D.1x

DC load (resistive)

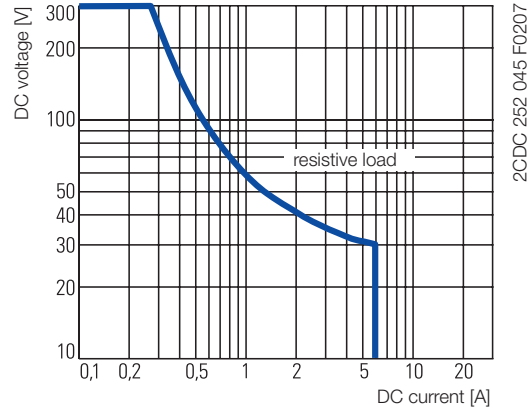

CT-D.1x

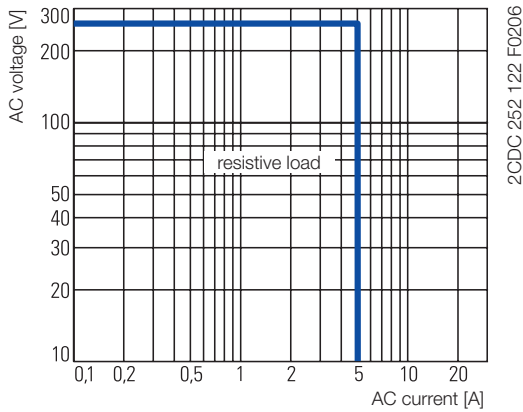

CT-D.2x

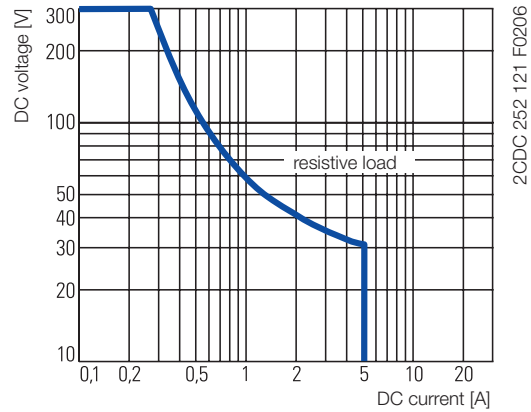

CT-D.2x

Derating factor F for inductive AC load

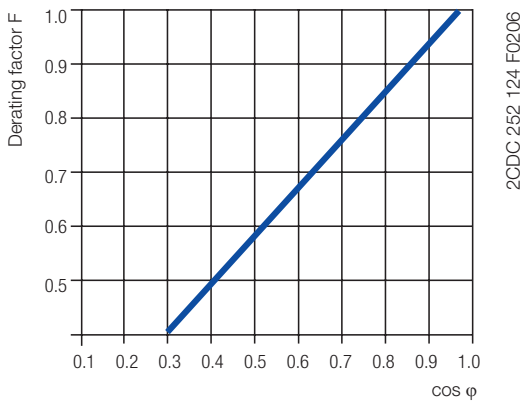

Contact lifetime

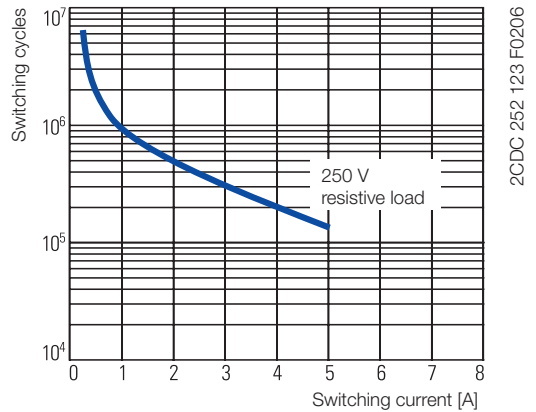

CT-D range

Wiring notes, Dimensional drawings

Wiring notes for devices with control input

A parallel load to the control input is possible

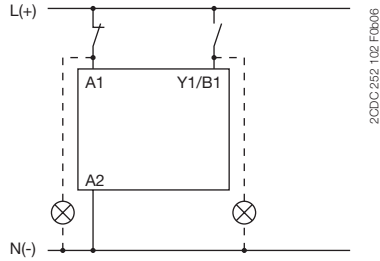

Dimensional drawings

dimensions in mm

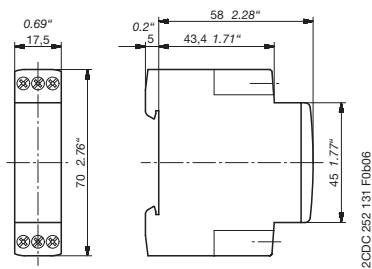

CT-D devices with 1 c/o contact or 2 n/o contacts

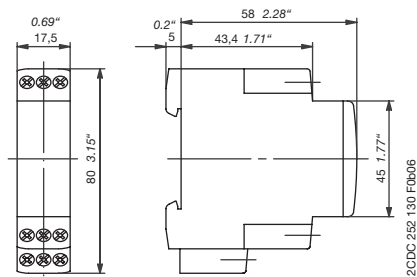

CT-D devices with 2 c/o contacts

CT-E range

Product group picture

1



CT-E range

Table of contents

CT-E Range	
Product group picture	1/17
Table of contents	1/18
Benefits and advantages	1/19
Ordering details	1/20
Function diagrams	1/22
Connection diagrams	1/27
Connection diagrams, Technical diagrams	1/28
Technical data	1/29
Wiring notes, Dimensional drawings	1/31
Notes	1/32

CT-E range

Benefits and advantages

1

Characteristics

- Diversity:
 - 2 multifunction timers
 - 56 single-function timers
 - 4 switching relays
- Control supply voltages:
 - Dual range: 24 V AC/DC
 - Single range: 110-130 V AC, 220-240 V AC
 - Wide range: 24-240 V AC/DC (CT-MFE)
- Time ranges
 - 5 single ranges: 0.05-1 s, 0.1-10 s, 0.3-30 s, 3-300 s, 0.3-30 min
 - 8 time ranges: 0.05 s - 100 h (CT-MFE)
- Devices with 1 c/o (SPDT) contact (250 V / 4 A) or solid-state output for high switching frequencies (thyristor 0.8 A)
- Switching relay CT-IRE for added switching contacts with either side-by-side or diagonally positioned connection terminals
- Approvals / Marks (details see page 1/4)



Benefits

Direct reading scales ①

Direct setting of the time delay without any additional calculation provides accurate time delay adjustment.

LEDs for status indication ②

All actual operational states are displayed by front-face LEDs, thus simplifying commissioning and troubleshooting.

Connection screws in M3 (PoziDrive 1) ③

Easy and fast tightening and release of the connection screws with pozidrive, pan- or crosshead screwdriver.

Solid-state output ④

Devices with solid-state output are the perfect solution for high operation cycles.

Synonyms

used expression	alternative expression(s)	used expression	alternative expression(s)
1 c/o contact	SPDT	voltage-related	wet / non-floating
2 c/o contacts	DPDT	volt-free	dry / floating

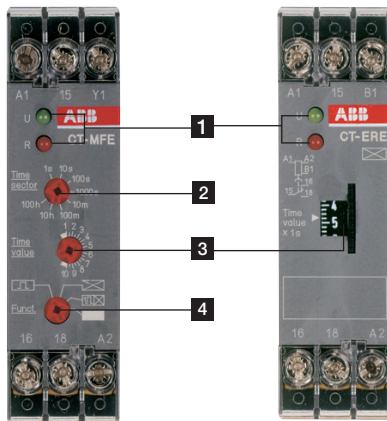

Operating controls

- 1 LEDs for status indication
 U - green LED: control supply voltage applied
 R2: red LED: output relay energized
- 2 Time range adjustment (only multifunctional devices)
- 3 Fine adjustment of the time delay
- 4 Preselection of the timing function (only multifunctional devices)

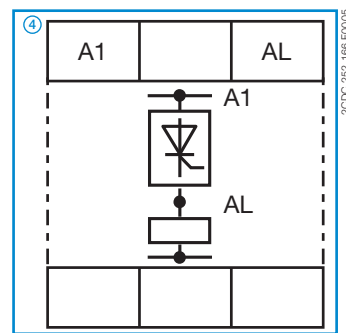
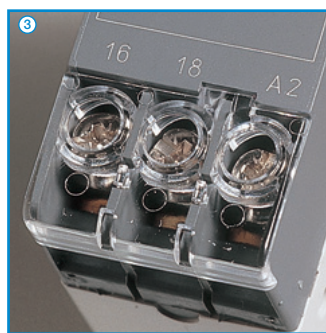
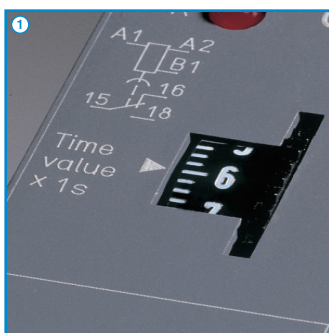

CT-E range

Ordering details

Description

The CT-E range with its excellent price/performance ratio offers an ideal solution for serial applications. 56 single-function devices with 5 different time ranges as well as 2 multifunction timers with 6 functions and 8 time ranges offer the highest possible flexibility for almost every application. For high operating cycles, contact-free CT-E timers with solid-state output are available.

Ordering details

Timing function	Rated control supply voltage	Time ranges	Control Input	Output	Type	Order code	Price	Weight (1 pce)
							1 pce	kg (lb)
Multifunctional ¹⁾	24-240 V AC/DC	8 (0.05 s - 100 h)	■	1 c/o	CT-MFE	1SVR550029R8100		0.08 (0.18)
ON-delay	24 V AC/DC, 220-240 V AC	0.1-10 s	-	1 c/o	CT-ERE	1SVR550107R1100		0.08 (0.18)
		0.3-30 s				1SVR550107R4100		
		3-300 s				1SVR550107R2100		
	0.3-30 min	1SVR550107R5100						
	110-130 V AC	0.1-10 s				1SVR550100R1100		
		0.3-30 s				1SVR550100R4100		
3-300 s		1SVR550100R2100						
OFF-delay	24 V AC/DC	0.1-10 s	■	1 c/o	CT-AHE	1SVR550118R1100		0.08 (0.18)
		0.3-30 s				1SVR550118R4100		
		3-300 s				1SVR550118R2100		
	110-130 V AC	0.1-10 s				1SVR550110R1100		
		0.3-30 s				1SVR550110R4100		
		3-300 s				1SVR550110R2100		
OFF-delay ²⁾	24 V AC/DC, 220-240 V AC	0.1-10 s	-	1 c/o	CT-ARE	1SVR550127R1100		0.08 (0.18)
		0.3-30 s				1SVR550127R4100		
		3-300 s				1SVR550127R2100		
	110-130 V AC	0.1-10 s				1SVR550120R1100		
		0.3-30 s				1SVR550120R4100		
		3-300 s				1SVR550120R2100		
Impulse-ON	24 V AC/DC, 220-240 V AC	0.1-10 s	-	1 c/o	CT-VWE	1SVR550137R1100		0.08 (0.18)
		0.3-30 s				1SVR550137R4100		
		3-300 s				1SVR550137R2100		
	110-130 V AC	0.1-10 s				1SVR550130R1100		
		0.3-30 s				1SVR550130R4100		
		3-300 s				1SVR550130R2100		
Impulse-OFF ²⁾	24 V AC/DC	0.05-1 s	-	1 c/o	CT-AWE	1SVR550158R3100		0.08 (0.18)
	110-130 V AC					1SVR550150R3100		
	220-240 V AC					1SVR550151R3100		



CT-MFE



CT-AHE

- ☒ ON-delay
- OFF-delay
- 1☒ Impulse-ON
- 1☒ Impulse-OFF
- ☒ Flasher starting with ON
- ☒ Flasher starting with OFF
- ☒ Pulse former

¹⁾ Functions: ON-delay, OFF-delay with auxiliary voltage, Impulse-ON, Impulse-OFF with auxiliary voltage, Flasher starting with ON, Flasher starting with OFF, Pulse former

²⁾ without auxiliary voltage, True Off-delay timer

■ Control input with voltage-related triggering
- no triggering

CT-E range

Ordering details

1



CT-AWE



CT-IRE

Bestellangaben

Timing function	Rated control supply voltage	Time ranges	Control Input	Output	Type	Order code	Price 1 pce	Weight (1 pce) kg (lb)
Impulse-OFF	24 V AC/DC	0.1-10 s	■	1 c/o	CT-AWE	1SVR550148R1100		0.08 (0.18)
		0.3-30 s				1SVR550148R4100		
		3-300 s				1SVR550148R2100		
	110-130 V AC	0.1-10 s				1SVR550140R1100		
		0.3-30 s				1SVR550140R4100		
		3-300 s				1SVR550140R2100		
	220-240 V AC	0.1-10 s				1SVR550141R1100		
		0.3-30 s				1SVR550141R4100		
		3-300 s				1SVR550141R2100		
Flasher starting with OFF	24 V AC/DC, 220-240 V AC	0.1-10 s	-	1 c/o	CT-EBE ⁶⁾	1SVR550167R1100		0.08 (0.18)
	110-130 V AC					1SVR550160R1100		
Star-delta change-over twice ON-delayed	24 V AC/DC, 220-240 V AC	0.1-10 s	-	1 c/o	CT-YDE ^{1) 2)}	1SVR550207R1100		0.08 (0.18)
		0.3-30 s				1SVR550207R4100		
	3-300 s	1SVR550207R2100						
	0.1-10 s	1SVR550200R1100						
110-130 V AC	0.3-30 s	1SVR550200R4100						
	3-300 s	1SVR550200R2100						
Star-delta change-over with impuls	24 V AC/DC, 220-240 V AC	0.3-30 s	-	1 n/o + 1 n/c	CT-SDE ^{2) 7)}	1SVR550217R4100		0.08 (0.18)
	110-130 V AC					1SVR550210R4100		
	380-415 V AC					1SVR550212R4100		
Multifunctional ⁸⁾	24-240 V AC/DC	0.1-10 s, 3-300 s	-		CT-MKE ^{5) 8)}	1SVR550019R0000		0.08 (0.18)
ON-delay	24-240 V AC/DC	0.1-10 s	-	solide-state	CT-EKE	1SVR550509R1000		0.08 (0.18)
		0.3-30 s				1SVR550509R4000		
		3-300 s				1SVR550509R2000		
OFF-delay	24-240 V AC	0.1-10 s	-		CT-AKE	1SVR550519R1000		0.08 (0.18)
		0.3-30 s				1SVR550519R4000		
Switching relay	24 V AC/DC		-	1 c/o	CT-IRE ³⁾	1SVR550228R9100		0.08 (0.18)
	220-240 V AC/DC					1SVR550221R9100		
	24 V AC/DC					1SVR550238R9100		
	220-240 V AC/DC					1SVR550231R9100		

- ⊠ ON-delay
- OFF-delay
- 1⊠ Impulse-ON
- 1⊠ Impulse-OFF
- ⊠ Flasher starting with ON
- ⊠ Flasher starting with OFF
- ⊠ Pulse former
- Switching relay
- △ Star-delta change-over twice ON-delayed
- △ Star-delta change-over with impulse
- ⊠ Pulse generator starting with ON or OFF

1) without auxiliary voltage
 2) with fixed transition time
 3) A1/A2 diagonal
 4) A1/A2 on top
 5) solid-state output, functions and time range selection via external jumpers
 6) symmetric ON & OFF times
 7) common contact
 8) Functions: ON-delay (AC/DC), Impuls-ON (AC only), Flasher starting with OFF (AC only)

■ Control input with voltage-related triggering
 - no triggering

Notice

CT...KE are solid-state timers with thyristor output for 2-wire applications. They are connected directly in series with the control coil of contactors or relays. Voltage should not be applied without a load connected, because there is no current limiting in the unit.

CT-E range

Function diagrams

Remarks

Legend

- Control supply voltage not applied / Output contact open
- Control supply voltage applied / Output contact closed
- A1-Y1/B1 Control input with voltage-related triggering

Terminal designations on the device and in the diagrams

- The c/o contact is always designated **15-16/18**.
- The n/o contacts are designated with **15-16** and **15-18**.
- Control supply voltage is always applied to terminals **A1-A2/B1**.

Function of the red LED

The red LED **R** glows as soon as the output relay energizes and turns off when the output relay de-energizes.

☒ **ON-delay (Delay on make)** **CT-ERE, CT-MFE**

Applying control supply voltage starts timing. When the selected time delay is complete, the output relay energizes. If control supply voltage is interrupted, the output relay de-energizes and the time delay is reset. Interrupting control supply voltage before the time delay is complete, resets the time delay. The output relay does not energize.

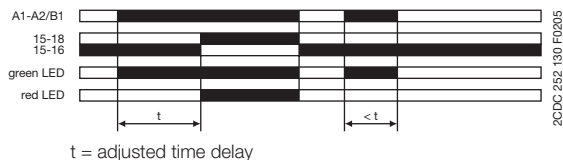

■ **OFF-delay, with auxiliary voltage (Delay on break)** **CT-AHE, CT-MFE**

This function requires continuous control supply voltage for timing. Timing is controlled by control input A1-Y1. If the control input is closed, the output relay energizes. If control input A1-Y1 is opened, the selected time delay starts. When the time delay is complete, the output relay de-energizes. If control input A1-Y1 is closed before the time delay is complete, the time delay is reset. Timing starts again when the control input re-opens.

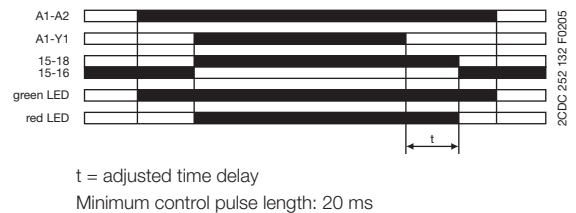

CT-E range

Function diagrams

1

OFF-delay, without auxiliary voltage (true delay on break) CT-ARE

The OFF-delay function without auxiliary voltage does not require continuous control supply voltage for timing. Applying control supply voltage, energizes the output relay. If control supply voltage is interrupted, the OFF-delay starts. When timing is complete, the output relay de-energizes. If control supply voltage is re-applied before the time delay is complete, the time delay is reset and the output relay remains energized. Control supply voltage must be applied for the minimum energizing time (200 ms), for proper operation.

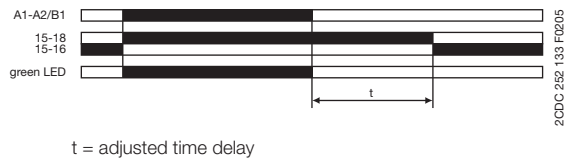

Impulse-ON (Interval) CT-VWE, CT-MFE

The output relay energizes immediately when control supply voltage is applied and de-energizes after the selected time delay is complete. If control supply voltage is interrupted before the time delay is complete, the output relay de-energizes and the time delay is reset. Control input A1-Y1 has to be jumpered, when this timing function is selected.

CT-VWE:

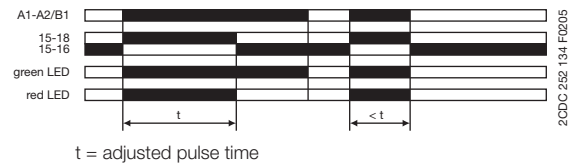

CT-MFE:

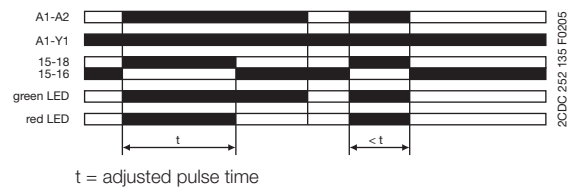

Impulse-OFF, without auxiliary voltage (True trailing edge interval) CT-AWE

The Impulse-OFF function without auxiliary voltage does not require continuous control supply voltage for timing. If control supply voltage is interrupted, the output relay energizes and the OFF time starts. When timing is complete, the output relay de-energizes. If control supply voltage is re-applied before the time delay is complete, the time delay is reset and the output relay de-energizes. Control supply voltage must be applied for the minimum energizing time (200 ms), for proper operation.

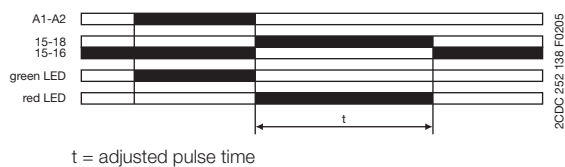

Impulse-OFF, with auxiliary voltage (Trailing edge interval) CT-AWE

This function requires continuous control supply voltage for timing. Timing is controlled by control input A1-Y1. If the control input is opened, the output relay energizes and timing begins. When the selected time delay is complete, the output relay de-energizes. Interrupting control supply voltage or closing control input A1-Y1, before the time delay is complete, de-energizes the output relay and resets the time delay.

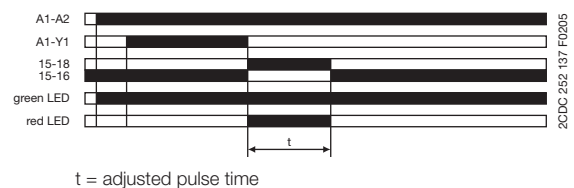

CT-E range

Function diagrams

Flasher starting with ON (Recycling equal times, ON first) CT-MFE

Applying control supply voltage starts timing with symmetrical ON & OFF times. The cycle starts with an ON time first. If control supply voltage is interrupted, the output relay de-energizes and the time delay is reset.

Control input A1-Y1 has to be open, when this timing function is selected.

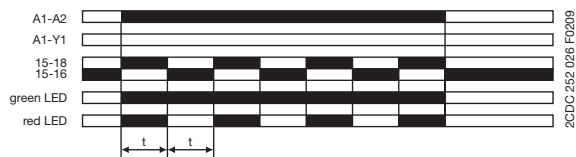

t = adjusted flashing time

Flasher starting with OFF (Recycling equal times, OFF first) CT-EBE, CT-MFE

Applying control supply voltage starts timing with symmetrical ON & OFF times. The cycle starts with an OFF time first. If control supply voltage is interrupted, the output relay de-energizes and the time delay is reset.

Control input A1-Y1 has to be jumpered, when this timing function is selected.

CT-EBE:

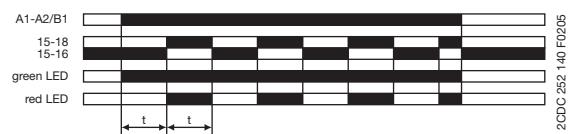

t = adjusted flashing time

CT-MFE:

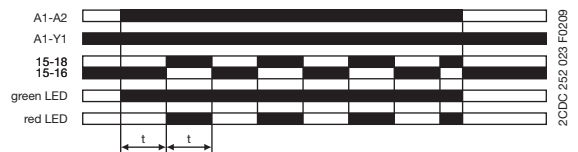

t = adjusted flashing time

Pulse former (Single shot) CT-MFE

Closing the control input A1-Y1, with control supply voltage applied, energizes the output relay for the selected ON time. Operating the control input during timing has no effect. When the ON time is complete, the output relay de-energizes. Timing can be restarted by re-closing control input A1-Y1. If control supply voltage is interrupted during timing, the output relay de-energizes and the ON time is reset.

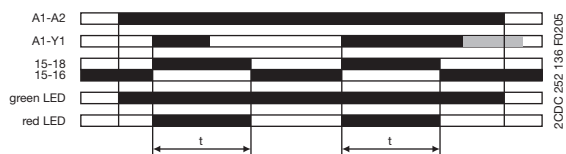

t = adjusted pulse time

Switching relay CT-IRE

The switching relay may be used to increase the number of available contacts or to reinforce contacts, or as a coupling/decoupling interface. Applying control supply voltage, energizes the output relay. The output relay de-energizes if control supply voltage is interrupted.



CT-E range

Function diagrams

1

☒☒ Star-delta change-over CT-YDE

Applying control supply voltage energizes the star contactor (K1) and the line contactor (K2) and begins the set starting time. When the starting time is complete, contact 15-16 de-energizes the star contactor (K1). Now, the fix transition time starts. When the transition time is complete, contact 15-16 energizes the delta contactor (K3).

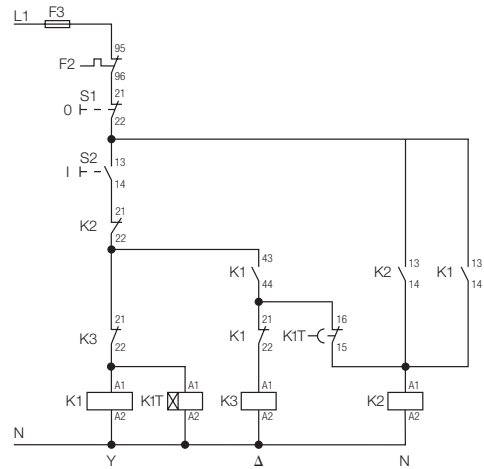
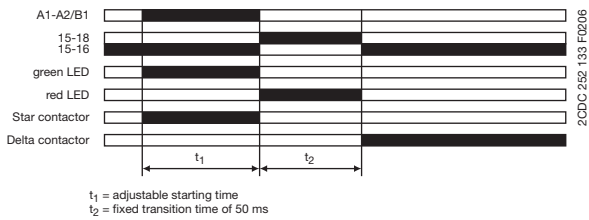

Control circuit diagram

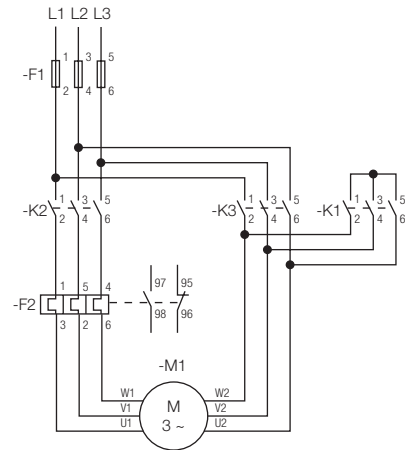

Power circuit diagram

☒☒ Star-delta change-over CT-SDE

Applying control supply voltage energizes the star contactor (K1) and the line contactor (K2) and begins the set starting time. When the starting time is complete, contact 15-16 de-energizes the star contactor (K1). Now, the fix transition time starts. When the transition time is complete, contact 15-18 energizes the delta contactor (K3).

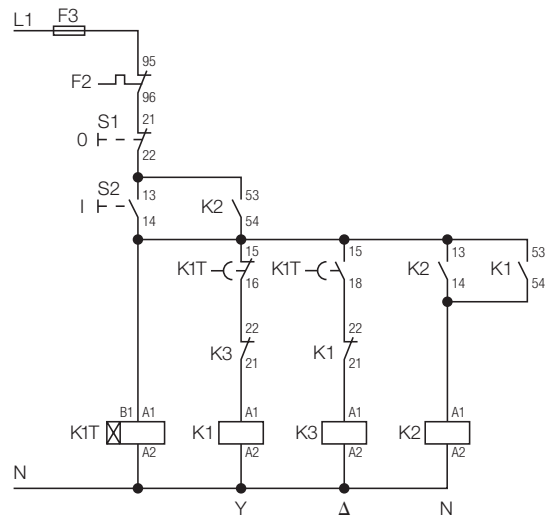
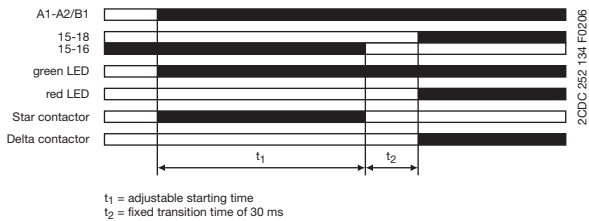

Control circuit diagram

CT-E range

Function diagrams

Multifunction timer CT-MKE

Functions and time ranges are programmed by simply plugging in external wire jumpers.

ON-delay (Delay on Make)

Without external connection. Timing begins when control supply voltage is applied to terminal A1 and the load connected in series with A2. When the selected time delay is complete, the load energizes. If control supply voltage is interrupted, the load de-energizes and the time delay is reset. Interrupting supply voltage before the time delay is complete, resets the time delay. The load does not energize.

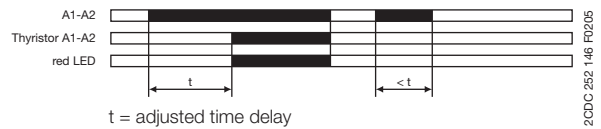

Impulse-ON (Interval)

External connection X1-X4 required. The load energizes and timing starts when control supply voltage is applied to terminal A1 and the load connected in series with A2. When the selected time delay is complete, the load de-energizes. Interrupting control supply voltage before the time delay is complete, de-energizes the load and resets the time delay.

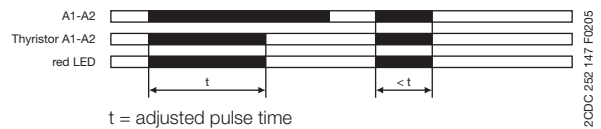

Flasher, starting with ON

External connection X1-X4 and X2-X4 required. When control supply voltage is applied to terminal A1 and the load connected in series with A2, the load energizes and de-energizes with the selected ON & OFF times. The ON & OFF times are equal. The cycle starts with an ON time first (load energized). If control supply voltage is interrupted, the load de-energizes and the time delay is reset.

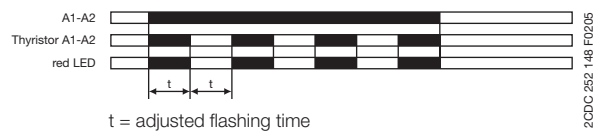

Flasher, starting with OFF

External connection X2-X4 required. When control supply voltage is applied to terminal A1 and the load connected in series with A2, the load energizes and de-energizes with the selected ON & OFF times. The ON & OFF times are equal. The cycle starts with an OFF time first (load de-energized). If control supply voltage is interrupted, the load de-energizes and the time delay is reset.

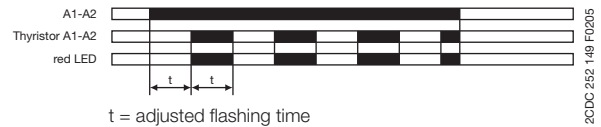

Programming the time ranges

X₃-X₄ jumpered: 0,1-10 s

X₃-X₄ open: 3-300 s

ON-delay (Delay on make) CT-EKE

Timing begins when control supply voltage is applied to terminal A1 and the load connected in series with AL. When the selected time delay is complete, the load energizes. The green LED glows as long as the load is energized.

If control supply voltage is interrupted, the load de-energizes and the time delay is reset. Interrupting control supply voltage before the time delay is complete, resets the time delay. The load does not energize.

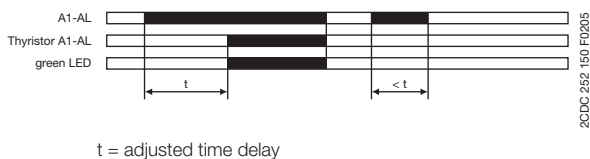

OFF-delay, with auxiliary voltage (Delay on break) CT-AKE

The OFF-delay function with auxiliary voltage requires continuous control supply voltage at terminal A1, and the load connected in series with AL, for timing.

Timing is controlled by control input Y2-A2. When the control input is closed, the load energizes. If the control input is opened, the selected time delay starts (minimum control pulse length is 20 ms). The green LED glows as long as the load is energized. When the selected time delay is complete, the load de-energizes. If control input Y2-A2 is closed before the time delay is complete, the time delay is reset and the load remains energized. Timing starts again when the control input is re-opened. Interrupting control supply voltage resets the time delay and de-energizes the load.



Notice:

CT...KE are solid-state timers with thyristor output for 2-wire applications. They are connected directly in series with the control coil of contactors or relays. Voltage should not be applied without a load connected, because there is no current limiting in the unit.

CT-E range

Connection diagrams

1

CT-MFE

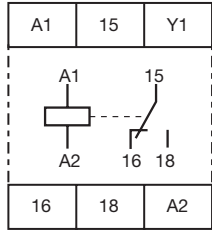

2CDC 252 152 F0005

A1-A2 Supply: 24-240 V AC/DC
 A1-Y1 Control input
 15-16/18 c/o contact

CT-ERE

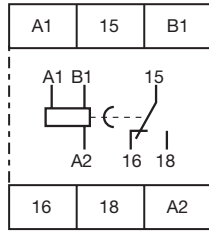

2CDC 252 153 F0005

A1-A2 Supply: 220-240 V AC or 110-130 V AC
 A1-B1 Supply: 24 V AC/DC
 15-16/18 c/o contact

CT-AHE¹⁾

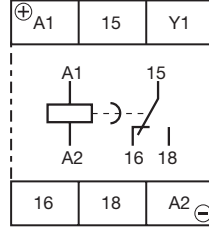

2CDC 252 154 F0005

A1(+)-A2(-) Supply: 24 V AC/DC or 110-240 V AC or 220-240 V AC
 A1-Y1 Control input
 15-16/18 c/o contact

CT-ARE

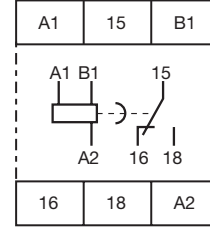

2CDC 252 155 F0005

A1-A2 Supply: 220-240 V AC or 110-130 V AC
 A1-B1 Supply: 24 V AC/DC
 15-16/18 c/o contact

CT-VWE

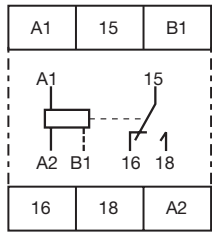

2CDC 252 156 F0b05

A1-A2 Supply: 220-240 V AC or 110-130 V AC
 A1-B1 Supply: 24 V AC/DC
 15-16/18 c/o contact

CT-AWE

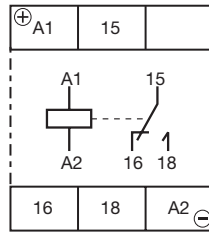

2CDC 252 157 F0b05

Device without aux. voltage
 A1(+)-A2(-) Supply: 24 V AC/DC or 110-240 V AC or 220-240 V AC
 15-16/18 c/o contact

CT-AWE¹⁾

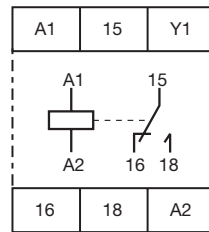

2CDC 252 158 F0b05

Device with aux. voltage
 A1-A2 Supply: 24 V AC/DC or 110-240 V AC or 220-240 V AC
 A1-Y1 Control input
 15-16/18 c/o contact

CT-EBE

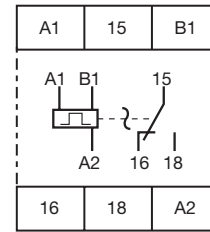

2CDC 252 159 F0005

A1-A2 Supply: 220-240 V AC or 110-130 V AC
 A1-B1 Supply: 24 V AC/DC
 15-16/18 c/o contact

CT-YDE

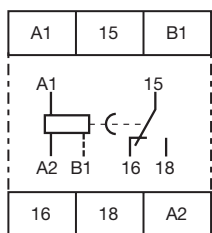

2CDC 252 160 F0005

A1-A2 Supply: 220-240 V AC or 110-130 V AC
 A1-B1 Supply: 24 V AC/DC
 15-16/18 c/o contact

CT-SDE

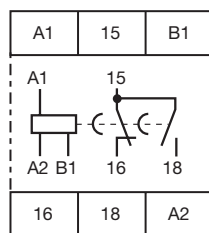

2CDC 252 161 F0005

Device: 1SVR 550 217 R4100
 A1-A2 Supply: 220-240 V AC
 A1-B1 Supply: 24 V AC/DC
 15-16 n/c contact
 15-18 n/o contact with common contact

CT-SDE

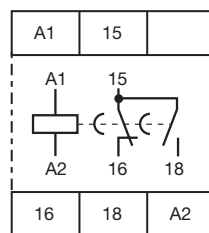

2CDC 252 162 F0005

Devices: 1SVR 550 210 R4100, 1SVR 550 212 R4100
 A1-A2 Supply: 110-130 V AC or 380-415 V AC
 15-16 n/c contact
 15-18 n/o contact with common contact

CT-IRE

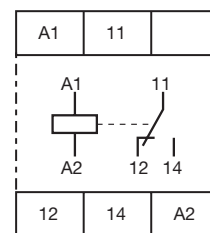

2CDC 252 163 F0005

Supply terminals diagonally positioned
 A1-A2 Supply: 24 V AC/DC or 220-240 V AC/DC
 11-12/14 c/o contact

CT-E range

Connection diagrams, Technical diagrams

CT-IRE

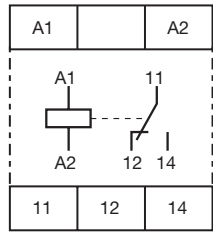

2CDC 252 164 F0005

Supply terminals on one side of the device

A1-A2 Supply: 24 V AC/DC or 220-240 V AC/DC
11-12/14 c/o contact

CT-MKE

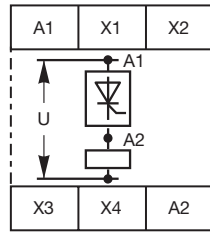

2CDC 252 165 F0005

A1-A2 Supply: 24-240 V AC/DC
A1-A2 Thyristor
X1-X4 Timing function adjustment
X2-X4 Timing function adjustment
X3-X4 Time range adjustment
(Details see function diagrams)

CT-EKE

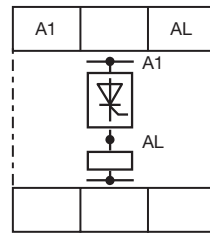

2CDC 252 166 F0005

A1-AL Supply: 24-240 V AC/DC
A1-AL Thyristor

CT-AKE

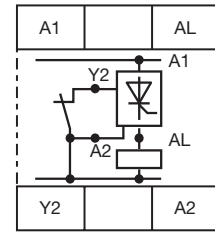

2CDC 252 167 F0005

A1-AL Supply: 24-240 V AC
A1-AL Thyristor
Y2-A2 Control input

¹⁾ Wiring notes 1/31

Technical diagrams

Load limit curves AC load (resistive)

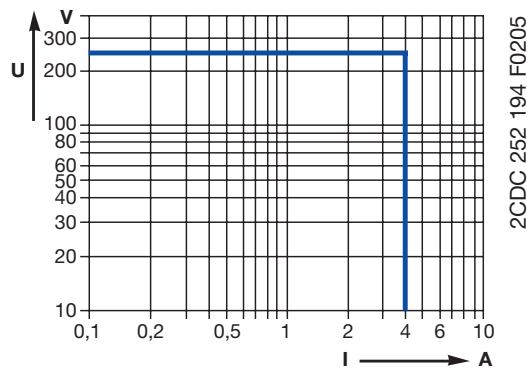

DC load (resistive)

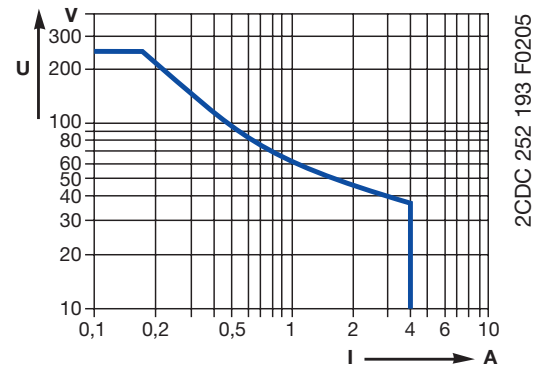

220 V 50 Hz AC1
360 cycles/h

Derating factor F for inductive AC load

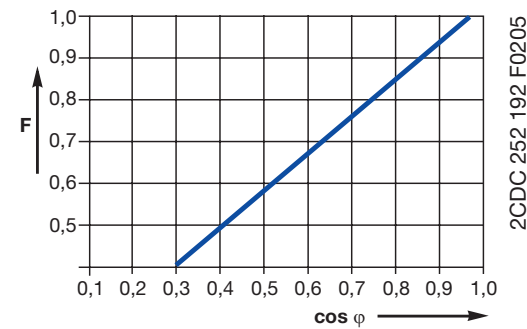

Contact lifetime

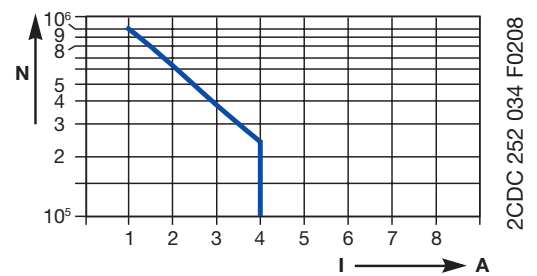

CT-E range

Technical data

1

Technical data

Data at $T_a = 25\text{ °C}$ and rated values, unless otherwise indicated

		CT-E (relays)	CT-E (solid-state)
Input circuit - Supply circuit			
Rated control supply voltage U_s	A1-A2, A1-AL	24-240 V AC/DC	
	A1-A2, A1-AL	24-240 V AC	
	A1-A2	110-130 V AC	-
	A1-A2	220-240 V AC	-
	A1-A2	380-415 V AC	-
	A1-B1	24 V AC/DC	-
Rated control supply voltage U_s tolerance		-15...+10 %	
Rated frequency	AC/DC versions	DC or 50/60 Hz	
	AC versions	50/60 Hz	
Typical current / power consumption	24-240 V AC/DC, 24-240 V AC	approx. 1.0-2.0 VA/W	
	110-130 V AC, 220-240 V AC	approx. 2.0 VA	-
	380-415 V AC	approx. 3.0 VA	-
	24 V AC/DC	approx. 1.0 VA/W	-
Minimum energizing time	CT-ARE, CT-AWE w/o aux. voltage	200 ms	-
Current consumption while timing		-	≤ 2 mA (24-60 V AC/DC) ≤ 8 mA (60-240 V AC/DC) (CT-AKE only AC)
Input circuit - Control circuit			
Kind of triggering		voltage-related triggering	-
Control input, Control function	A1-Y1	start timing external	-
Parallel load / polarized		no / yes ¹⁾	-
Minimum control pulse length		20 ms	-
Control voltage potential		see rated control supply voltage	-
Timing circuit			
Time ranges	1 of 5 time ranges per single-function device 8 time ranges 0.05 s - 100 h (CT-MFE)	0.05-1 s / 0.1-10 s / 0.3-30 s / 3-300 s / 0.3-30 min 1.) 0.05-1 s 2.) 0.5-10 s 3.) 5-100 s 4.) 50-1000 s 5.) 0.5-10 min 6.) 5-100 min 7.) 0.5-10 h 8.) 5-100 h	-
	2 time ranges 0.1-300 s (CT-MKE)	-	1.) 0.1-10 s 2.) 3-300 s
Recovery time		<50 ms CT-ARE: <200 ms CT-AWE, CT-SDE: <400 ms CT-YDE: <500 ms	CT-EKE: <50 ms CT-MKE: <100 ms CT-AKE: <300 ms
Accuracy within the rated control supply voltage tolerance		$\Delta t < 0.5\% / V$	
Accuracy within the temperature range		$\Delta t < 0.1\% / \text{°C}$	
Repeat accuracy (constant parameters)		CT-MFE: $\Delta t < 0.06\% / \text{°C}$	-
Star-delta transition time	CT-YDE / CT-SDE	50 ms / 30 ms	-
Output circuit			
Kind of output	15-16/18 CT-SDE: 15-16, 15-18	Relay, 1 c/o contact 1 n/c, 1 n/o contract with common contact	-
Contact material	A1-A2, A1-AL	-	Thyristor
Rated operational voltage U_o	IEC/EN 60947-1	250 V	
Maximum switching voltage		250 V AC, 250 V DC	
Rated operational current I_o (IEC/EN 60947-5-1)	AC12 (resistive) at 230 V	4 A	-
	AC15 (inductive) at 230 V	3 A	-
	DC12 (resistive) at 24 V	4 A	-
	DC13 (inductive) at 24 V	2 A	-

¹⁾ CT-MFE: yes / no

CT-E range

Technical data

1

		CT-E (relays)	CT-E (solid-state)
AC rating (UL 508)	Utilization category (Control Circuit Rating Code)	B 300	-
	max. rated operational voltage	300 V AC	-
	Maximum continuous thermal current at B300	5 A	-
	max. making/breaking apparent power at B300	3600 VA / 360 VA	-
Mechanical lifetime		30 x 10 ⁶ switching cycles	-
Electrical lifetime	at AC12, 230 V, 4 A	0.1 x 10 ⁶ switching cycles	-
Max. fuse rating to achieve short-circuit protection (IEC/EN 60947-5-1)	n/c contact	10 A fast-acting, CT-ARE: 5 A	-
	n/o contact	10 A fast-acting, CT-ARE: 5 A	-
Minimum load current		-	CT-MKE: 20 mA CT-EKE, CT-AKE: 10 mA
Maximum load current		-	CT-MKE: 0.8 A at Ta = 20 °C CT-EKE, CT-AKE: 0.7 A
Load current reduction / Derating		-	10 mA/°C
Maximum surge current		-	CT-MKE: ≤ 20 A for t ≤ 20 ms CT-EKE, CT-AKE: ≤ 15 A
Voltage drop in connected state		-	≤ 3 V
Cable length between solid-state timer and connected load at 50 Hz and a cable capacity of 100 pF/m :	at 24 V AC	-	220 m / 22 nF
	at 42 V AC	-	100 m / 10 nF
	at 60 V AC	-	65 m / 6.5 nF
	at 110 V AC	-	50 m / 5 nF
	at 240 V AC	-	22 m / 2.2 nF
General data			
Duty time		100%	
Dimensions (W x H x D)		22.5 x 78 x 78.5 mm (0.886 x 3.07 x 3.09 in)	
Weight		approx. 80 g (0.176 lb)	
Mounting		DIN rail (IEC/EN 60715)	
Mounting position		any	
Minimum distance to other units	horizontal / vertical	no / no	
Degree of protection	housing / terminals	IP50 / IP20	
Electrical connection			
Wire size	fine-strand with wire end ferrule	2 x 0.75-1.5 mm ² (2 x 18-16 AWG)	
	fine-strand without wire end ferrule	2 x 1-1.5 mm ² (2 x 18-16 AWG)	
	rigid	2 x 0.75-1.5 mm ² (2 x 18-16 AWG)	
Stripping length		10 mm (0.39 in)	
Tightening torque		0.6-0.8 Nm (5.31-7.08 lb.in)	
Environmental data			
Ambient temperature ranges	operation / storage	-20...+60 °C / -40...+85 °C	
Damp heat	IEC/EN 60068-2-30	24 h cycle, 55 °C, 93 % rel., 96 h	
Operational reliability	IEC/EN 60068-2-6	6 g	
Mechanical resistance	IEC/EN 60068-2-6	10 g	
Isolation data			
Rated impulse withstand voltage U _{imp} between all isolated circuits	IEC/EN 60664	4 kV; 1.2/50 μs	
Pollution category	IEC/EN 60664, IEC/EN 60255-5	III/C	
Overvoltage category	IEC/EN 60664, IEC/EN 60255-5	III/C	
Rated insulation voltage U _i between supply circuit, control circuit and output circuit	input circuit / output circuit	300 V (supply up to 240 V) 500 V (supply up to 440 V)	
Test voltage between all isolated circuits	routine test	2.5 kV, 50 Hz, 1 s	
Standards			
Product standard		IEC 61812-1, EN 61812-1 + A11, DIN VDE 0435 Teil 201	
Low Voltage Directive		2006/95/EC	
EMC Directive		2004/108/EC	
Electromagnetic compatibility			
Interference immunity to		IEC/EN 61000-6-2	
electrostatic discharge	IEC/EN 61000-4-2	Level 3 (6 kV / 8 kV)	
radiated, radio-frequency electromag- netic field	IEC/EN 61000-4-3	Level 3 (10 V/m)	
electrical fast transient / burst	IEC/EN 61000-4-4	Level 3 (2 kV / 5 kHz)	
surge	IEC/EN 61000-4-5	Level 4 (2 kV L-L)	
conducted disturbances, induced by radio-frequency fields	IEC/EN 61000-4-6	Level 3 (10 V)	
Interference emission		IEC/EN 61000-6-4	

„Approvals and marks“ see page 1/4.

CT-E range

Wiring notes, Dimensional drawings

1

Wiring notes

for single-function devices with control contact (CT-AHE, CT-AWE with auxiliary voltage)

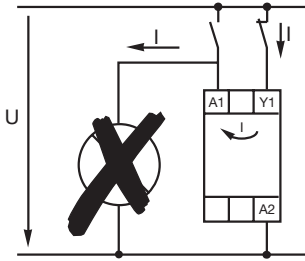

2CDC 252 200 F0b05

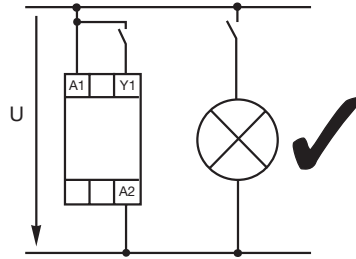

2CDC 252 199 F0b05

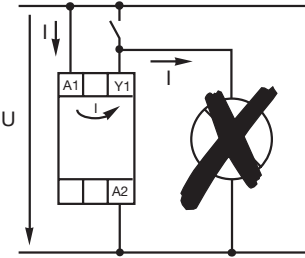

2CDC 252 198 F0b05

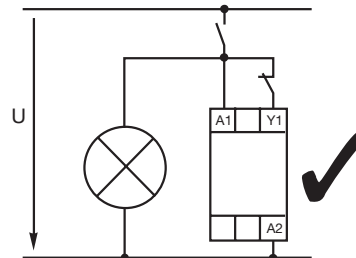

2CDC 252 201 F0b05

Dimensional drawing

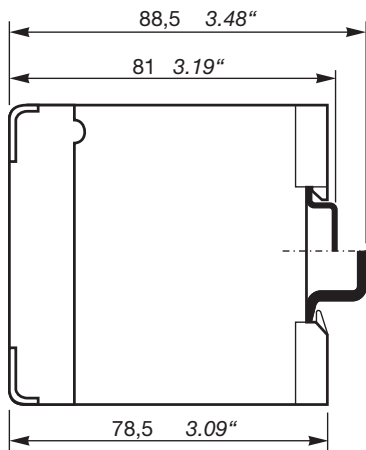

Dimensions in mm

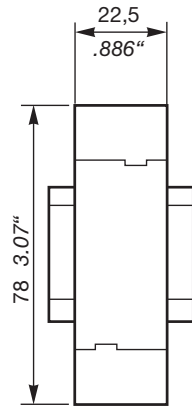

2CDC 252 189 F0b05

CT-E range Notes

A series of horizontal dotted lines for taking notes, spanning most of the page width.

CT-S range

Product group picture

1



CT-S range

Table of contents

CT-S Range	
Product group picture	1/33
Table of contents	1/34
Benefits and advantages	1/35
Ordering details - multifunctional	1/37
Ordering details - singlefunctional	1/38
Ordering details - Accessories	1/39
Ordering details - Accessories	1/40
Function diagrams	1/41
Connection diagrams	1/49
Technical data	1/52
Technical diagrams	1/55
Wiring notes, Dimensional drawings	1/56

CT-S range

Benefits and advantages

1

Characteristics

- Diversity:
 - 8 multifunction timers
 - 13 single-function timers
 - 8 switching relays
- Control supply voltages:
 - Multi range: 24-48 V DC, 24-240 V AC
 - Wide range: 24-240 V AC/DC
 - Single range: 380-440 V AC
- Innovative connection technology
 - Double-chamber cage connection terminals
 - Easy Connect Technology
- Devices with:
 - 1 or 2 c/o (SPDT) contacts
 - 2nd c/o contact can be selected as instantaneous contact ¹⁾
 - Remote potentiometer connection ¹⁾
 - Control input with volt-free or voltage-related triggering e.g. to start timing, pause timing
 - Extended operating temperature range down to -40 °C ¹⁾
- Sealable transparent cover for protection against unauthorized changes of time values
- Integrated marker label
- Approvals / Marks (partly pending, details see page 1/4)



¹⁾ selected devices

Operating controls

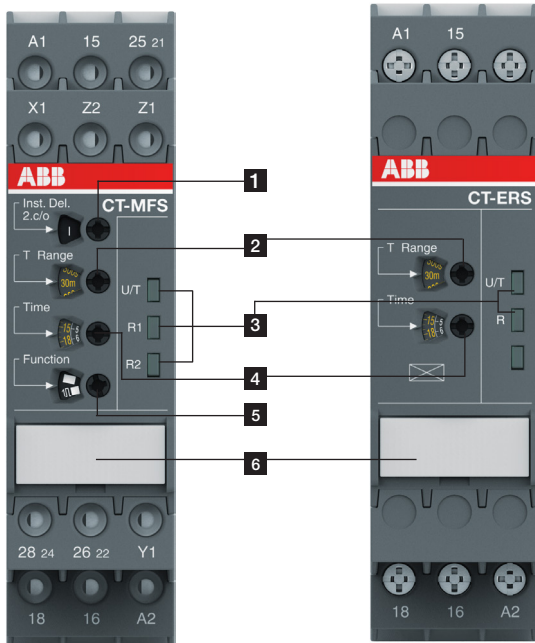

- 1 2nd contact as an instantaneous contact
- 2 Preselection of the time range
- 3 Indication of operational states
 U/T: control supply voltage applied / timing
 R: Output relay energized
- 4 Fine adjustment of time delay
- 5 Preselection of timing function
- 6 Marker label

CT-S range

Benefits and advantages

Easy Connect Technology ①

Tool-free wiring and excellent vibration resistance. Push-in terminals provide connection of wires up to $2 \times 0,5 - 1,5 \text{ mm}^2$ ($2 \times 20 - 16 \text{ AWG}$), rigid or fine-strand with or without wire end ferrules. The extended type designators for products with push-in terminals are indicated by a **P** following the extended type designator e.g. CT-xxS.xx**P**.

Double-chamber cage connection terminals ②

Double-chamber cage connection terminals provide connection of wires up to $2 \times 0,5-2,5 \text{ mm}^2$ ($2 \times 20-14 \text{ AWG}$) rigid or fine-strand, with or without wire end ferrules. Potential distribution does not require additional terminals. The extended type designators for products with double-chamber cage connection terminals are indicated by a **S** following the extended type designator e.g. CT-xxS.xx**S**.

Time range preselection and fine adjustment ③

Direct assignment of the preselected time range to the fine adjustment potentiometer scale by multicolor scales.

Higher utility class ④

The Easy Connect Technology provides excellent vibration resistance with gas tight push-in terminals – the right solution for harsh environment. Selected products of the electronic timers and measuring and monitoring relays comply to the latest rail standards NF F 16-101/102, EN 45545, EN 50155 and more standards which are relevant for railway applications. Find more information in the rail brochure 2CDC110084B0201.

LEDs for status indication ⑤

All actual operational states are displayed by front-face LEDs, thus simplifying commissioning and troubleshooting.

Integrated marker label ⑥

Integrated marker labels allow the product to be marked quickly and simply. No additional marker labels are required.

Sealable transparent cover ⑦

Protection against unauthorized changes of time and threshold values. Available as an accessory.

Snap-On housing ⑧

Tool-free DIN rail installation and deinstallation of the electronic timer.

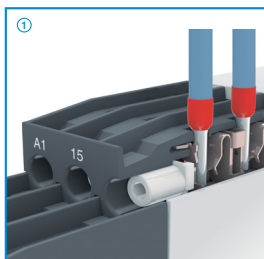

2CDC 253 025 F0011

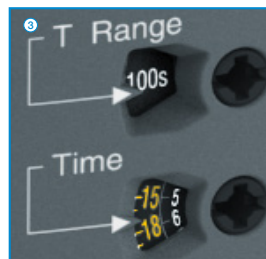

2CDC 253 035 F0011

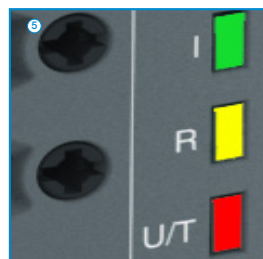

2CDC 252 006 F0012

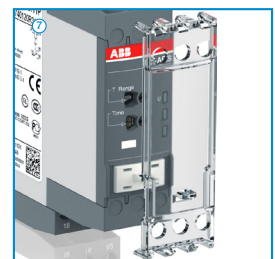

2CDC 255 006 S0011

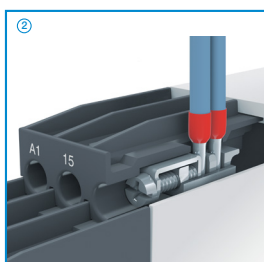

2CDC 253 025 F0011

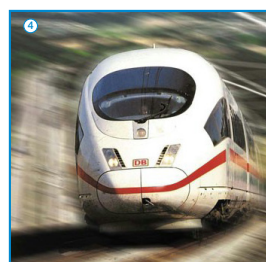

2CDC 253 035 F0011

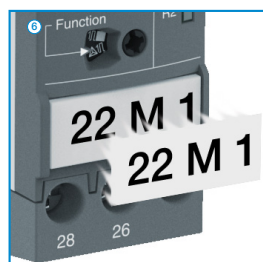

2CDC 253 007 F0012

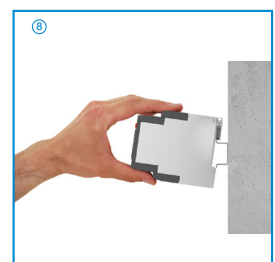

2CDC 253 013 F0013

CT-S range

Ordering details - multifunctional

1



CT-MVS.21P



CT-MBS.22P

Description

The highly sophisticated CT-S range in ABB's new S-range housing offers two different types of connection terminals and is ideally suited for universal use. Two different connection technologies are available:

- Double-chamber cage connection terminals
- Easy Connect Technology

Accessories:

The CT-S range offers the possibility of using accessories such as a remote potentiometer to adjust the time delay or a sealable, transparent cover to protect against unauthorized changes of time and threshold values.

Timing function	Rated control supply voltage	Time ranges	Control input	Output	Type	Order code	Price 1 pce	Weight (1 pce) kg (lb)
Multifunctional ⁵⁾	24- 240 V AC/DC	10 (0.05 - 300 h)	■	2 c/o	CT-MVS.21S ^{1) 2) 3)}	1SVR730020R0200	0.148 (0.326)	
					CT-MVS.21P ^{1) 2) 3)}	1SVR740020R0200	0.136 (0.30)	
	CT-MVS.22S				1SVR730020R3300	0.142 (0.313)		
	CT-MVS.22P				1SVR740020R3300	0.131 (0.289)		
	CT-MVS.23S				1SVR730021R2300	0.144 (0.317)		
	CT-MVS.23P				1SVR740021R2300	0.133 (0.293)		
Multifunctional ⁶⁾	24- 240 V AC	10 (0.05 s - 300 h)	■	1 c/o	CT-MVS.12S	1SVR730020R3100	0.107 (0.236)	
					CT-MVS.12P	1SVR740020R3100	0.102 (0.225)	
Multifunctional ⁷⁾	24- 240 V AC	2x10 (0.05 s - 300 h)	■	2 c/o	CT-MXS.22S ⁴⁾	1SVR730030R3300	0.142 (0.313)	
					CT-MXS.22P ⁴⁾	1SVR740030R3300	0.131 (0.289)	
Multifunctional ⁸⁾	24- 240 V AC/DC	10 (0.05 s - 300 h)	-	2 c/o	CT-MFS.21S ^{1) 2) 3)}	1SVR730010R0200	0.145 (0.32)	
					CT-MFS.21P ^{1) 2) 3)}	1SVR740010R0200	0.133 (0.293)	
	24- 240 V AC				CT-MBS.22S ^{2) 3)}	1SVR730010R3200	0.14 (0.309)	
CT-MBS.22P ^{2) 3)}		1SVR740010R3200	0.129 (0.284)					
Multifunctional ⁹⁾	24- 240 V AC	10 (0.05 s - 300 h)	-	2 c/o	CT-WBS.22S	1SVR730040R3300	0.123 (0.271)	
					CT-WBS.22P	1SVR740040R3300	0.115 (0.254)	

- ON-delay (accumulative)
- OFF-delay without aux. voltage
- Impulse-ON
- Impulse-OFF
- Symmetrical ON-delay and OFF-delay
- Flasher starting with ON
- Flasher starting with OFF
- Pulse generator starting
- Star-delta change-over with impulse
- Pulse former
- ON/OFF-function
- Star-delta change-over twice ON-delayed
- with ON or OFF
- Pulse generator starting with ON or OFF
- Single-pulse generator
- Impulse-ON/OFF
- Flasher starting with ON
- Flasher starting with OFF
- fixed impulse with adjustable time delay
- Adjustable impulse with fixed time delay

- Control input with voltage-related triggering
- Control input with volt-free triggering
- / □ two control input with volt-free triggering - no triggering
- S: screw connection
- P: push-in / easy connect

¹⁾ Extended temperature range -40 °C

²⁾ Remote potentiometer connection

³⁾ 2nd c/o contact selectable as instantaneous contact

⁴⁾ 2 remote potentiometer connections

⁵⁾ Functions: ON-delay, OFF-delay with auxiliary voltage, Impulse-ON, Impulse-OFF with auxiliary voltage, Symmetrical ON- and OFF-delay, Flasher starting with ON or OFF, Star-delta change-over with impulse, Pulse former, Accumulative ON-delay, ON/OFF-function

⁶⁾ Functions: ON-delay, OFF-delay with auxiliary voltage, Impulse-ON, Impulse-OFF with auxiliary voltage, Symmetrical ON- and OFF-delay, Flasher starting with ON or OFF, Pulse former, Accumulative ON-delay, ON/OFF-function

⁷⁾ Functions: Select function via DIP switches behind the marker label on the front of the unit, asymmetrical ON- and OFF-delay, Impulse-ON/OFF, Pulse generator starting with ON or OFF, Single pulse generator, ON/OFF-function

⁸⁾ Functions: ON-delay, OFF-delay with auxiliary voltage, Impulse-ON, Impulse-OFF with auxiliary voltage, Symmetrical ON- and OFF-delay, Flasher starting with ON, Flasher starting with OFF, Star-delta change-over with impulse, Pulse former, ON/OFF-function

⁹⁾ Functions: Flasher starting with ON, Flasher starting with OFF, Impulse-ON, ON-delay, fixed impulse with adjustable time delay, Adjustable impulse with fixed time delay, ON/OFF-function

CT-S range

Ordering details - singlefunctional



2CDC 251 030 V0011

CT-ERS.21P



2CDC 251 033 V0011

CT-AHS.22P



2CDC 251 040 V0011

CT-SDS.23P



2CDC 251 079 F0007

CT-IRS.35

- ☒(+) ON-delay (accumulative)
- OFF-delay without aux. voltage
- 1☒ Impulse-ON
- ☒ Flasher starting with ON
- ☒ Flasher starting with OFF
- ON/OFF-function
- 1☒ Impulse-ON/OFF
- ☒ Flasher starting with ON
- ☒ Flasher starting with OFF
- ☒ fixed impulse with adjustable time delay
- 1☒ Adjustable impulse with fixed time delay
- △ Star-delta change-over

Timing function	Rated control supply voltage	Time ranges	Control input	Output	Type	Order code	Price 1 pce	Weight (1 pce) kg (lb)
ON-delay (accumulative)	24-240 V AC/DC	10 (0.05 s - 300 h)	-	2 c/o	CT-ERS.21S ¹⁾	1SVR730100R0300		0.13 (0.287)
					CT-ERS.21P ¹⁾	1SVR740100R0300		0.121 (0.267)
	CT-ERS.22S				1SVR730100R3300		0.121 (0.267)	
	CT-ERS.22P				1SVR740100R3300		0.113 (0.249)	
OFF-delay	24-240 V AC/DC	10 (0.05 s - 300 h)	■	2 c/o	CT-ERS.12S	1SVR730100R3100		0.106 (0.234)
					CT-ERS.12P	1SVR740100R3100		0.101 (0.222)
	24-48 V DC, 24-240 V AC				CT-APS.21S ¹⁾	1SVR730180R0300		0.146 (0.322)
					CT-APS.21P ¹⁾	1SVR740180R0300		0.125 (0.276)
	24-48 V DC, 24-240 V AC				CT-APS.22S	1SVR730180R3300		0.138 (0.304)
					CT-APS.22P	1SVR740180R3300		0.127 (0.28)
OFF-delay ⁵⁾	24-240 V AC/DC	7 (0.05 s - 10 min)	■	1 c/o	CT-APS.12S	1SVR730180R3100		0.109 (0.24)
					CT-APS.12P	1SVR740180R3100		0.103 (0.227)
	24-48 V DC, 24-240 V AC				CT-AHS.22S	1SVR730110R3300		0.136 (0.30)
					CT-AHS.22P	1SVR740110R3300		0.125 (0.276)
OFF-delay ⁵⁾	110-127 V AC oder 110 V DC	7 (0.05 s - 10 min)	-	-	CT-ARS.11S	1SVR730120R3100		0.106 (0.234)
					CT-ARS.11P	1SVR740120R3100		0.10 (0.22)
	200-240 V AC/DC				CT-ARS.21S	1SVR730120R3300		0.124 (0.273)
					CT-ARS.21P	1SVR740120R3300		0.115 (0.254)
OFF-delay ⁵⁾	110-127 V AC oder 110 V DC	7 (0.05 s - 10 min)	-	-	CT-VBS.17 ⁷⁾	1SVR430261R6000		0.123 (0.271)
					CT-VBS.18 ⁷⁾	1SVR430261R5000		0.118 (0.26)
Star-delta change-over ⁸⁾	24-48 V DC, 24-240 V AC	7 (0.05 s - 10 min)	-	2 n/o	CT-SDS.22S	1SVR730210R3300		0.114 (0.251)
					CT-SDS.22P	1SVR740210R3300		0.108 (0.238)
	380-440 V AC				CT-SDS.23S	1SVR730211R2300		0.118 (0.26)
					CT-SDS.23P	1SVR740211R2300		0.112 (0.247)
ON/OFF-function	24 V AC/DC	-	-	2 c/o	CT-IRS.16	1SVR430220R9100		0.121 (0.267)
	110-240 V AC				CT-IRS.14	1SVR430221R7100		0.126 (0.278)
					CT-IRS.26	1SVR430220R9300		0.135 (0.298)
	24 V AC/DC				CT-IRS.24	1SVR430221R7300		0.141 (0.311)
	110-240 V AC				CT-IRS.26G ⁸⁾	1SVR430230R9300		0.147 (0.324)
					CT-IRS.24G ⁸⁾	1SVR430231R7300		0.15 (0.331)
	24 V AC/DC				CT-IRS.36	1SVR430220R9400		0.159 (0.351)
	220-240 V AC				CT-IRS.35	1SVR430221R1400		0.161 (0.355)

¹⁾ Extended temperature range -40 °C
²⁾ Remote potentiometer connection
³⁾ 2nd c/o contact selectable as instantaneous contact
⁴⁾ 2 remote potentiometer connections
⁵⁾ Without auxiliary voltage
⁶⁾ 50 ms transition time
⁷⁾ For DC contactor coils
⁸⁾ with gold-plated contacts
 ■ Control input with voltage-related triggering
 □ Control input with volt-free triggering
 ☒ / ☒ two control input with volt-free triggering
 - no triggering
 S: screw connection
 P: push-in / easy connect

CT-S range

Ordering details - Accessories

1

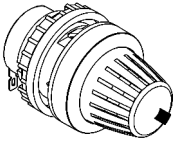

MT-x50B

2CDC 252 041 F0009



30 mm adapters

2CDC 252 042 F0009

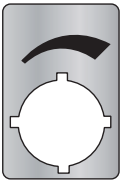

Marker label 29.6 x 44.5 mm

2CDC 252 043 F0009

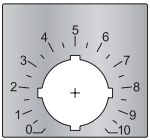

Marker label with scale 0-10
48.5 x 44.5 mm

2CDC 252 044 F0009

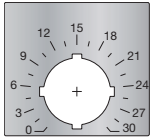

Marker label with scale 0-30
48.5 x 44.5 mm

2CDC 252 045 F0009

Remote potentiometer

50 k Ω \pm 20 % - 0,2 Ω , degree of protection IP66

Material	Diameter in mm	Type	Order code	Price 1 piece	Pack.- unit pieces	Weight 1 piece g / oz
Plastic, black	22.5	MT-150B	1SFA611410R1506		1	0.040
Plastic, chrome	22.5	MT-250B	1SFA611410R2506		1	0.040
Metal, chrome	22.5	MT-350B	1SFA611410R3506		1	0.048

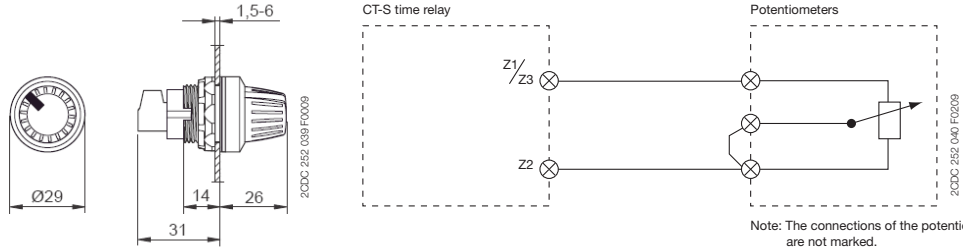

Note: Technical specifications see data sheet

30 mm adapter for attaching the potentiometer 22 mm in 30 mm mounting hole

Material	Type	Order code	Price 1 piece	Pack.- unit pieces	Weight 1 piece g / oz
Plastic, black	KA1-8029	1SFA616920R8029		1	
Metal, chrome	KA1-8030	1SFA616920R8030		1	

Marker label

Caption	Type	Order code	Price 1 piece	Pack.- unit pieces	Weight 1 piece g / oz
Symbol (see illustration)	SK 615 562-87	GJD6155620R0087		1	0.002
Scale 0 - 10	SK 615 562-88	GJD6155620R0088		1	0.002
Scale 0 - 30	MA16-1060	1SFA611940R1060		1	0.002

CT-S range

Ordering details - Accessories

Accessories for CT-S in new housing (1SVR7...)

Description	Type	Order code	Price	Pack.-unit	Weight
			1 piece	pieces	1 piece
			kg / lb		
Adapter for screw mounting	ADP.01	1SVR430029R0100		1	0.018 (0.040)
Sealable transparent cover	COV.11	1SVR730005R0100		1	0.004 (0.009)
Marker label for devices w/o DIP switches	MAR.01	1SVR366017R0100		10	0.001 (0.002)
Marker label for devices with DIP switches	MAR.12	1SVR730006R0000		10	0.001 (0.002)

Accessories for CT-S in old housing (1SVR4...)

Description	Type	Order code	Price	Pack.-unit	Weight
			1 piece	pieces	1 piece
			kg / lb		
Adapter for screw mounting	ADP.01	1SVR430029R0100		1	0.018 (0.040)
Sealable transparent cover	COV.01	1SVR430005R0100		1	0.004 (0.009)
Marker label for devices w/o DIP switches	MAR.01	1SVR366017R0100		10	0.001 (0.002)
Marker label for devices with DIP switches	MAR.02	1SVR430043R0000		10	0.001 (0.002)

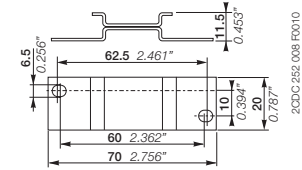

ADP.01

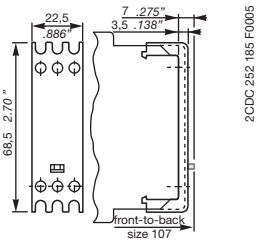

COV.01

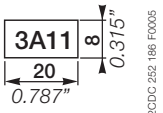

MAR.01

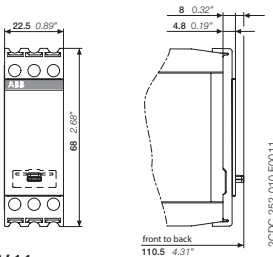

COV.11

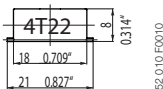

MAR.02

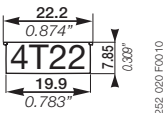

MAR.12

CT-S range

Function diagrams

1

Remarks

Legend

- Control supply voltage not applied / Output contact open
- Control supply voltage applied / Output contact closed

- A1-Y1/B1 Control input with voltage-related triggering
- Y1-Z2 Control input with volt-free triggering
- X1-Z2 Control input with volt-free triggering

Remote potentiometer connection:

When an external potentiometer is connected to the remote potentiometer connection (terminals **Z1-Z2**, **Z3-Z2** respectively), the internal, front-face potentiometer is disabled and the time adjustment is made via the external potentiometer.

2nd c/o contact selectable as instantaneous contact:

When switch position Inst. "I" is selected, the functionality of the 2nd c/o contact changes to an instantaneous contact. It acts like the c/o contacts of a switching relay, i.e. applying or interrupting the control supply voltage energizes or de-energizes the c/o contact. The designation of the 2nd c/o contact changes from **25-26/28** to **21-22/24**, when selected as instantaneous contact.

Terminal designations on the device and in the diagrams:

The 1st c/o contact is always designated **15-16/18**.
 The 2nd c/o contact is designated **25-26/28**, if it responds to the time delay.
 If the 2nd c/o contact is selected as an instantaneous contact, the designation **25-26/28** is replaced by **21-22/24**.
 Control supply voltage is always applied to terminals **A1-A2**.

Function of the yellow LEDs:

On devices without the function '2nd c/o contact selectable as instantaneous contact', the yellow LED **R** glows as soon as the output relay energizes and turns off when the output relay de-energizes.

Devices with the function '2nd c/o contact selectable as instantaneous contact' have two yellow LEDs, designated **R1** and **R2**. LED **R1** shows the status of the 1st c/o contact (**15-16/18**) and LED **R2** shows the status of the 2nd c/o contact (**25-26/28**, **21-22/24** resp.). LED **R1** or **R2** glow as soon as the corresponding output relay energizes and turns off when the corresponding output relay de-energizes.

ON-delay (Delay on make) CT-MVS, CT-ERS, CT-WBS

This function requires continuous control supply voltage for timing. Timing begins when control supply voltage is applied. The green LED flashes during timing. When the selected time delay is complete, the output relay energizes and the flashing green LED turns steady. If control supply voltage is interrupted, the output relay de-energizes and the time delay is reset.

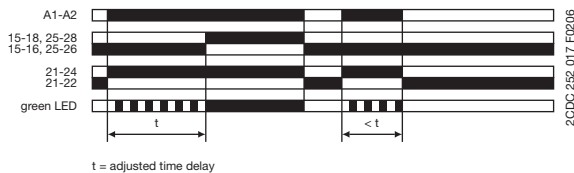

ON-delay (Delay on make) CT-MFS, CT-MBS

This function requires continuous control supply voltage for timing. If control input **Y1-Z2** is open, timing begins when control supply voltage is applied. Or, if control supply voltage is already applied, opening control input **Y1-Z2** also starts timing. The green LED flashes during timing. When the selected time delay is complete, the output relay energizes and the flashing green LED turns steady.

If control input **Y1-Z2** closes before the time delay is complete, the time delay is reset and the output relay remains de-energized.
 Pause timing / Accumulative ON-delay (CT-MFS):
 Timing can be paused by closing control input **X1-Z2**. The elapsed time t_1 is stored and continues from this time value when **X1-Z2** is re-opened. This can be repeated as often as required.

If control supply voltage is interrupted, the output relay de-energizes and the time delay is reset.

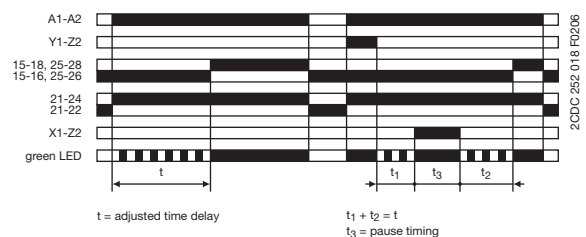

CT-S range

Function diagrams

⊠+ Accumulative ON-delay (Accumulative delay on make) CT-MVS

This function requires continuous control supply voltage for timing. Timing begins when control supply voltage is applied. The green LED flashes during timing. When the selected time delay is complete, the output relay energizes and the flashing green LED turns steady. Timing can be paused by closing control input **A1-Y1/B1**. The elapsed time t_1 is stored and continues from this time value when **A1-Y1/B1** is re-opened. This can be repeated as often as required. If control supply voltage is interrupted, the output relay de-energizes and the time delay is reset.

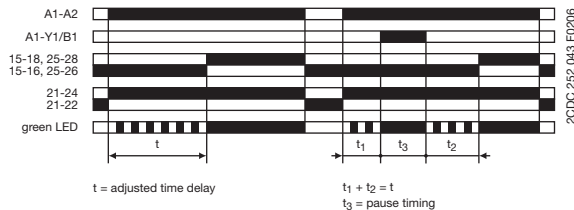

■ OFF-delay with auxiliary voltage (Delay on break) CT-MFS, CT-MBS, CT-AHS

This function requires continuous control supply voltage for timing. If control input **Y1-Z2** is closed, the output relay energizes immediately. If control input **Y1-Z2** is opened, the time delay starts. The green LED flashes during timing. When the selected time delay is complete, the output relay de-energizes and the flashing green LED turns steady. If control input **Y1-Z2** closes before the time delay is complete, the time delay is reset and the output relay does not change state. Timing starts again when control input **Y1-Z2** re-opens. Pause timing / Accumulative OFF-delay (CT-MFS): Timing can be paused by closing control input **X1-Z2**. The elapsed time t_1 is stored and continues from this time value when **X1-Z2** is re-opened. This can be repeated as often as required. If control supply voltage is interrupted, the output relay de-energizes and the time delay is reset.

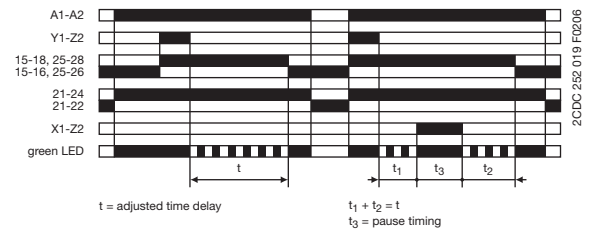

■ OFF-delay with auxiliary voltage (Delay on break) CT-MVS, CT-APS

This function requires continuous control supply voltage for timing. If control input **A1-Y1/B1** is closed, the output relay energizes immediately. If control input **A1-Y1/B1** is opened, the time delay starts. The green LED flashes during timing. When the selected time delay is complete, the output relay de-energizes and the flashing green LED turns steady. If control input **A1-Y1/B1** recloses before the time delay is complete, the time delay is reset and the output relay does not change state. Timing starts again when control input **A1-Y1/B1** re-opens. If control supply voltage is interrupted, the output relay de-energizes and the time delay is reset.

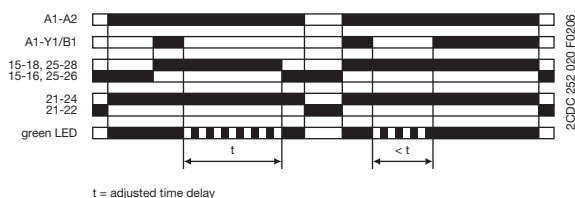

■ OFF-delay without auxiliary voltage (True delay on break) CT-ARS

The OFF-delay function without auxiliary voltage does not require continuous control supply voltage for timing. After a storage time of several months without any voltage, a formatting time of about 5 minutes is necessary. Applying control supply voltage energizes the output relay immediately. Applied control supply voltage is displayed by the glowing green LED. If control supply voltage is interrupted, the OFF-delay starts and the LED turns off. When timing is complete, the output relay de-energizes. For correct operation of the unit, it is necessary to complete the minimum energizing time. As soon as timing starts, the LED turns off.

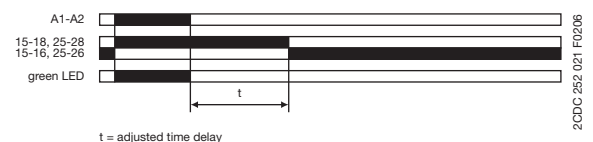

CT-S range

Function diagrams

1

OFF-delay without auxiliary voltage for DC contactor coils CT-VBS

The DC contactor coil connected to the output is energized when control supply voltage is applied.

If control supply voltage is disconnected, the DC contactor coil remains energized for a short time delay. This time delay depends on the coil drop-out voltage and on the wattage of the contactor coil.

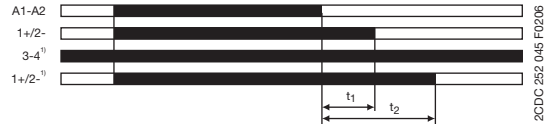

t_1 = OFF-delay (without jumper between terminals 3 and 4 ¹⁾)
 t_2 = OFF-delay (with jumper between terminals 3 and 4 ¹⁾)
¹⁾ only for version 200-240 V AC

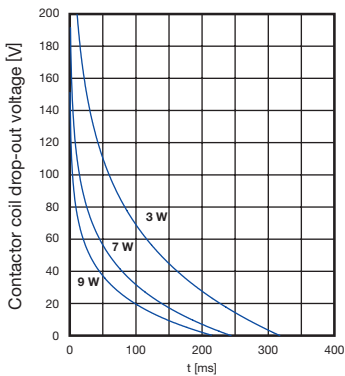

2CDC 252 127 F0205

Time delay guideline values
200-240 V AC version without jumper 3/4

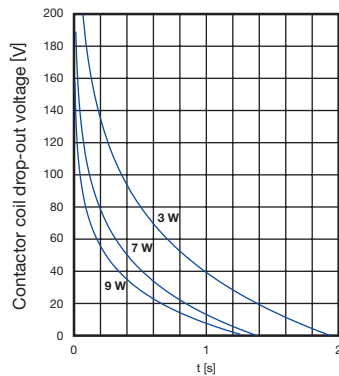

2CDC 252 128 F0205

Time delay guideline values
200-240 V AC version with jumper 3/4

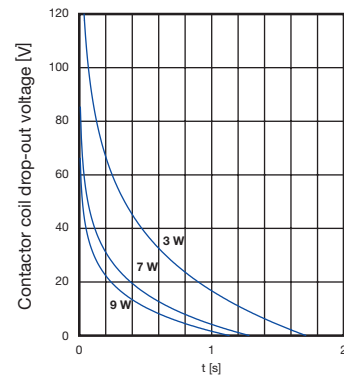

2CDC 252 129 F0205

Time delay guideline values
110-127 V AC version

Symmetrical ON-delay and OFF-delay (Symmetrical delay on make and delay on break) CT-MFS, CT-MBS

This function requires continuous control supply voltage for timing. Closing control input **Y1-Z2** starts the ON-delay t_1 . When timing is complete, the output relay energizes. Opening control input **Y1-Z2** starts the OFF-delay t_2 . Both timing functions are displayed by the flashing green LED. When the OFF-delay t_2 is complete, the output relay de-energizes. If control input **Y1-Z2** opens before the ON-delay t_1 is complete, the time delay is reset and the output relay remains de-energized. If control input **Y1-Z2** closes before the OFF-delay t_2 is complete, the time delay is reset and the output relay remains energized. Pause timing / Accumulative, symmetrical ON-delay and OFF-delay (CT-MFS): Timing can be paused by closing control input **X1-Z2**. The elapsed time t_{1a} or t_{2a} is stored and continues from this time value when **X1-Z2** is re-opened. This can be repeated as often as required. If control supply voltage is interrupted, the output relay de-energizes and the time delay is reset.

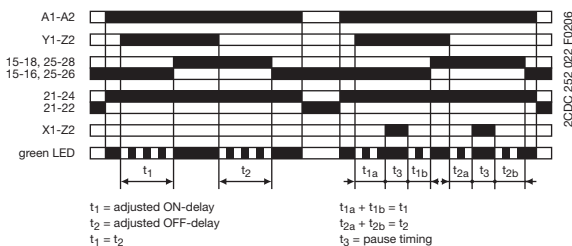

2CDC 252 022 F0206

t_1 = adjusted ON-delay
 t_2 = adjusted OFF-delay
 $t_1 = t_2$
 $t_{1a} + t_{1b} = t_1$
 $t_{2a} + t_{2b} = t_2$
 t_3 = pause timing

Symmetrical ON-delay and OFF-delay (Symmetrical delay on make and delay on break) CT-MVS

This function requires continuous control supply voltage for timing. Closing control input **A1-Y1/B1** starts the ON-delay t_1 . When timing is complete, the output relay energizes. Opening control input **A1-Y1/B1** starts the OFF-delay t_2 . Both timing functions are displayed by the flashing green LED. When the OFF-delay t_2 is complete, the output relay de-energizes. If control input **A1-Y1/B1** opens before the ON-delay t_1 is complete, the time delay is reset and the output relay remains de-energized. If control input **A1-Y1/B1** closes before the OFF-delay t_2 is complete, the time delay is reset and the output relay remains energized. If control supply voltage is interrupted, the output relay de-energizes and the time delay is reset.

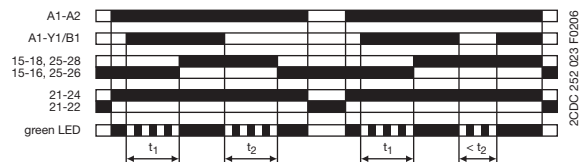

2CDC 252 023 F0206

t_1 = adjusted ON-delay
 t_2 = adjusted OFF-delay
 $t_1 = t_2$

CT-S range

Function diagrams

Asymmetrical ON-delay and OFF-delay (Asymmetrical delay on make and delay on break) CT-MXS

This function requires continuous control supply voltage for timing. Closing control input **A1-Y1/B1** starts the ON-delay t_1 . When timing is complete, the output relay energizes. Opening control input **A1-Y1/B1** starts the OFF-delay t_2 . When the OFF-delay is complete, the output relay de-energizes. Both timing functions are displayed by the flashing green LED. The ON-delay and OFF-delay are independently adjustable. If control input **A1-Y1/B1** opens before the ON-delay is complete ($<t_1$), the time delay is reset and the output relay remains de-energized. If control input **A1-Y1/B1** closes before the OFF-delay is complete ($<t_2$), the time delay is reset and the output relay remains energized. If control supply voltage is interrupted, the output relay de-energizes and the time delay is reset.

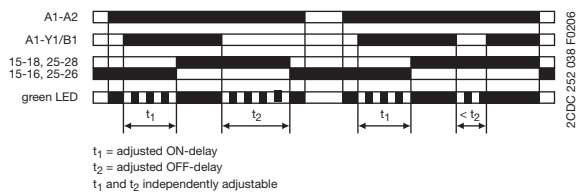

Impulse-ON (Interval) CT-MVS, CT-WBS

This function requires continuous control supply voltage for timing. The output relay energizes immediately when control supply voltage is applied and de-energizes after the set pulse time is complete. The green LED flashes during timing. When the selected pulse time is complete, the flashing green LED turns steady. If control supply voltage is interrupted, the output relay de-energizes and the time delay is reset.

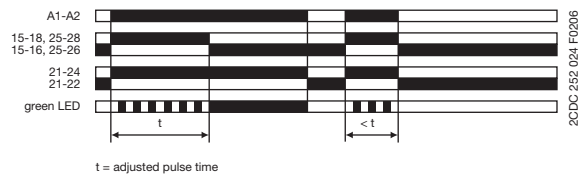

Impulse-ON (Interval) CT-MFS, CT-MBS

This function requires continuous control supply voltage for timing. The output relay energizes immediately when control supply voltage is applied and de-energizes after the set pulse time is complete. If control input **Y1-Z2** is open, timing begins when control supply voltage is applied. Or, if control supply voltage is already applied, opening control input **Y1-Z2** starts timing. The green LED flashes during timing. When the selected pulse time is complete, the output relay de-energizes and the flashing green LED turns steady. Closing control input **Y1-Z2**, before the pulse time is complete, de-energizes the output relay and resets the pulse time. Pause timing / Accumulative impulse-OFF (CT-MFS): Timing can be paused by closing control input **X1-Z2**. The elapsed time t_1 is stored and continues from this time value when **X1-Z2** is re-opened. This can be repeated as often as required. If control supply voltage is interrupted, the output relay de-energizes and the time delay is reset.

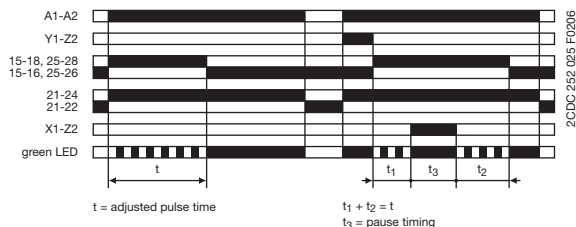

Impulse-OFF with auxiliary voltage (Trailing edge interval) CT-MFS, CT-MBS

This function requires continuous control supply voltage for timing. If control supply voltage is applied, opening control input **Y1-Z2** energizes the output relay immediately and starts timing. The green LED flashes during timing. When the selected pulse time is complete, the output relay de-energizes and the flashing green LED turns steady. Closing control input **Y1-Z2**, before the pulse time is complete, de-energizes the output relay and resets the pulse time. Pause timing / Accumulative impulse-OFF (CT-MFS): Timing can be paused by closing control input **X1-Z2**. The elapsed time t_1 is stored and continues from this time value when **X1-Z2** is re-opened. This can be repeated as often as required. If control supply voltage is interrupted, the output relay de-energizes and the time delay is reset.

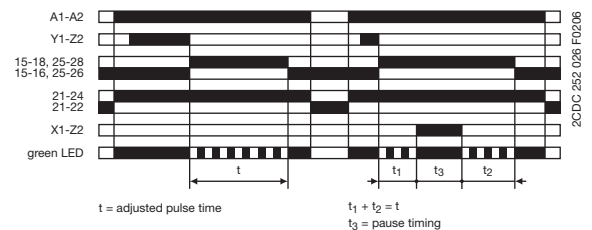

CT-S range

Function diagrams

1

Impulse-OFF with auxiliary voltage (Trailing edge interval) CT-MVS

This function requires continuous control supply voltage for timing. If control supply voltage is applied, opening control input **A1-Y1/B1** energizes the output relay immediately and starts timing. The green LED flashes during timing. When the selected pulse time is complete, the output relay de-energizes and the flashing green LED turns steady. Closing control input **A1-Y1/B1**, before the pulse time is complete, de-energizes the output relay and resets the pulse time. If control supply voltage is interrupted, the output relay de-energizes and the time delay is reset.

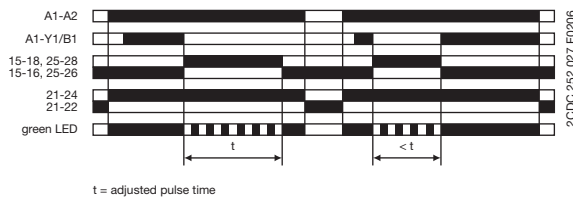

Impulse-ON and impulse-OFF (Interval and trailing edge interval) CT-MXS

This function requires continuous control supply voltage for timing. If control supply voltage is applied, closing control input **A1-Y1/B1** energizes the output relay immediately and starts the pulse time t_1 . The green LED flashes during timing. When t_1 is complete, the output relay de-energizes and the flashing green LED turns steady. Re-opening control input **A1-Y1/B1** energizes the output relay immediately and starts the pulse time t_2 . The green LED flashes during timing. When t_2 is complete, the output relay de-energizes and the flashing green LED turns steady. t_1 and t_2 are independently adjustable. If control input **A1-Y1/B1** changes state before the pulse time is complete, the output relay de-energizes and the pulse time is reset. If control input **A1-Y1/B1** changes state again, the interrupted pulse time restarts. If control supply voltage is interrupted, the output relay de-energizes and the time delay is reset.

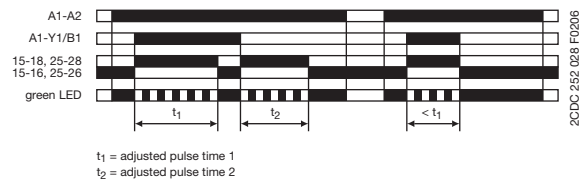

Flasher, starting with the ON time (Recycling equal times, ON first) CT-WBS

Applying control supply voltage starts timing with symmetrical ON & OFF times. The cycle starts with an ON time first. The ON & OFF times are displayed by the flashing green LED, which flashes twice as fast during the OFF time. If control supply voltage is interrupted, the output relay de-energizes and the time delay is reset.

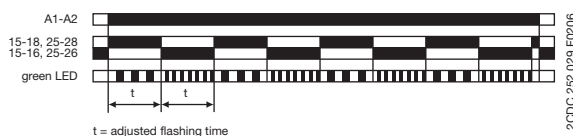

Flasher, starting with the OFF time (Recycling equal times, OFF first) CT-WBS

Applying control supply voltage starts timing with symmetrical ON & OFF times. The cycle starts with an OFF time first. The ON & OFF times are displayed by the flashing green LED, which flashes twice as fast during the OFF time. If control supply voltage is interrupted, the output relay de-energizes and the time delay is reset.

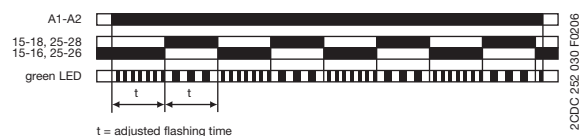

Flasher with reset, starting with the ON time (Recycling equal times with reset, ON first) CT-MFS, CT-MBS

Applying control supply voltage starts timing with symmetrical ON & OFF times. The cycle starts with an ON time first. The ON & OFF times are displayed by the flashing green LED, which flashes twice as fast during the OFF time. The time delay can be reset by closing control input **Y1-Z2**. Opening control input **Y1-Z2** starts the timer pulsing again with symmetrical ON & OFF times. If control supply voltage is interrupted, the output relay de-energizes and the time delay is reset.

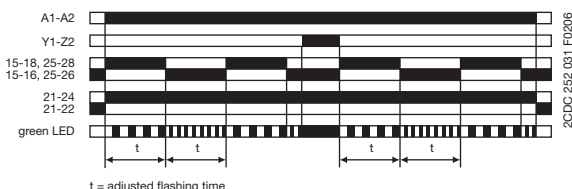

Flasher with reset, starting with the OFF time (Recycling equal times with reset, OFF first) CT-MFS, CT-MBS

Applying control supply voltage starts timing with symmetrical ON & OFF times. The cycle starts with an OFF time first. The ON & OFF times are displayed by the flashing green LED, which flashes twice as fast during the OFF time. The time delay can be reset by closing control input **Y1-Z2**. Opening control input **Y1-Z2** starts the timer pulsing again with symmetrical ON & OFF times. If control supply voltage is interrupted, the output relay de-energizes and the time delay is reset.

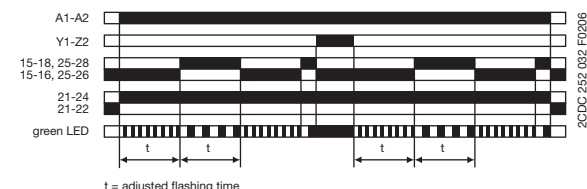

CT-S range

Function diagrams

Flasher, starting with the ON or OFF time (Recycling equal times, ON or OFF first) CT-MVS

Applying control supply voltage starts timing with symmetrical ON & OFF times. The cycle starts with an ON time first.

Closing control input **A1-Y1/B1**, with control supply voltage applied, starts the cycle with an OFF time first. The ON & OFF times are displayed by the flashing green LED, which flashes twice as fast during the OFF time.

If control supply voltage is interrupted, the output relay de-energizes and the time delay is reset.

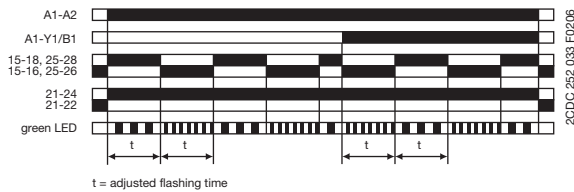

Pulse former (Single shot) CT-MFS, CT-MBS

This function requires continuous control supply voltage for timing.

Closing control input **Y1-Z2** energizes the output relay immediately and starts timing. Operating the control contact switch **Y1-Z2** during the time delay has no effect. The green LED flashes during timing. When the selected ON time is complete, the output relay de-energizes and the flashing green LED turns steady. After the ON time is complete, it can be restarted by closing control input **Y1-Z2**.

If control supply voltage is interrupted, the output relay de-energizes and the time delay is reset.

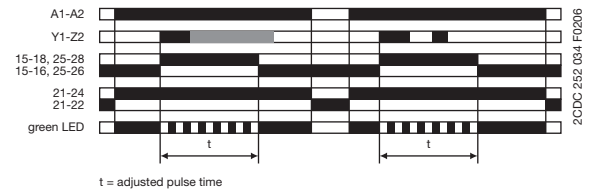

Pulse former (Single shot) CT-MVS

This function requires continuous control supply voltage for timing.

Closing control input **A1-Y1/B1** energizes the output relay immediately and starts timing. Operating the control contact switch **A1-Y1/B1** during the time delay has no effect. The green LED flashes during timing. When the selected ON time is complete, the output relay de-energizes and the flashing green LED turns steady. After the ON time is complete, it can be restarted by closing control input **A1-Y1/B1**.

If control supply voltage is interrupted, the output relay de-energizes and the time delay is reset.

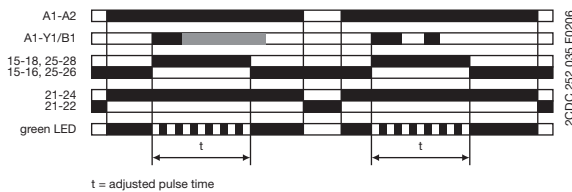

Pulse generator, starting with the ON or OFF time (Recycling unequal times, ON or OFF first) CT-MXS

This function requires continuous control supply voltage for timing.

Applying control supply voltage, with open control input **A1-Y1/B1**, starts timing with an ON time t_2 first. Applying control supply voltage, with closed control input **A1-Y1/B1**, starts timing with an OFF time t_1 first. The ON & OFF times are displayed by the flashing green LED, which flashes twice as fast during the OFF time.

The ON & OFF times are independently adjustable.

If control supply voltage is interrupted, the output relay de-energizes and the time delay is reset.

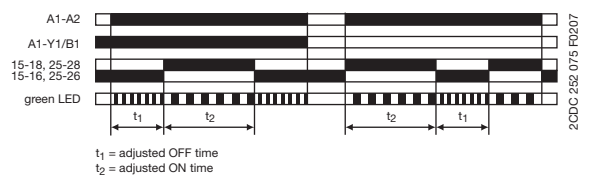

CT-S range

Function diagrams

1



Single-pulse generator, starting with the OFF time (Delay on make with interval output) CT-MXS

This function requires continuous control supply voltage for timing. Applying control supply voltage, or, if control supply voltage is already applied, opening control input **A1-Y1/B1** energizes the output relay after the OFF time t_1 is complete. When the following ON time t_2 is complete, the output relay de-energizes. The ON & OFF times are displayed by the flashing green LED, which flashes twice as fast during the OFF time. The ON & OFF times are independently adjustable. Closing control input **A1-Y1/B1**, with control supply voltage applied, de-energizes the output relay and resets the time delay. If control supply voltage is interrupted, the output relay de-energizes and the time delay is reset.

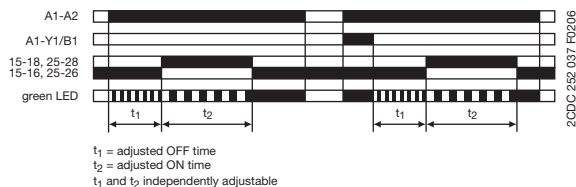

Fixed impulse with adjustable time delay (Delayed pulse output) CT-WBS

This function requires continuous control supply voltage for timing. The time delay t_1 starts when control supply voltage is applied. The green LED flashes during timing. When t_1 is complete, the output relay energizes for the fixed impulse time t_2 of 500 ms and the flashing green LED turns steady. If control supply voltage is interrupted, the time delay is reset. The output relay does not change state.

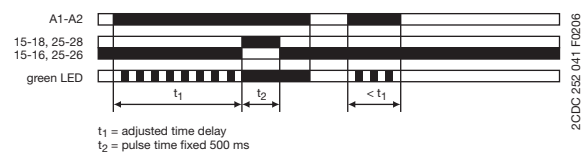

Adjustable impulse with fixed time delay (Delayed Interval) CT-WBS

This function requires continuous control supply voltage for timing. Applying control supply voltage starts the fixed time delay t_2 of 500 ms. When t_2 is complete, the output relay energizes and the selected pulse time t_1 starts. The green LED flashes during timing. When t_1 is complete, the output relay de-energizes and the flashing green LED turns steady. If control supply voltage is interrupted, the pulse time is reset. The output relay does not change state.

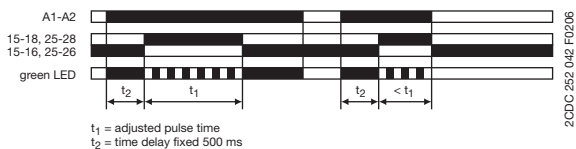

ON/OFF-Function CT-MFS, CT-MBS, CT-MVS, CT-MXS, CT-WBS

This function is used for test purposes during commissioning and troubleshooting. If the selected max. value of the time range is smaller than 300 h (front-face potentiometer "Time sector" \neq 300 h), applying control supply voltage energizes the output relay immediately and the green LED glows. Interrupting control supply voltage, de-energizes the output relay. If the selected max. value of the time range is 300 h (front-face potentiometer "Time sector" = 300 h) and control supply voltage is applied, the green LED glows, but the output relay does not energize. Time settings and operating of the control inputs have no effect on the operation.

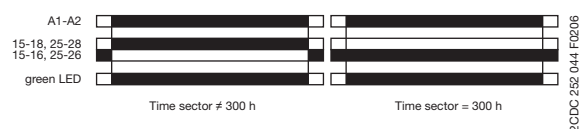

Switching relays CT-IRS

The switching relay may be used to increase the number of available contacts or to reinforce contacts, or as a coupling/decoupling interface. Approx. 10 ms after applying control supply voltage to terminals **A1-A2**, the output relay energizes. If control supply voltage is interrupted, the output relay de-energizes.



CT-S range

Function diagrams

△1□ Star-delta change-over with impulse function (Star-delta starting, interval/delay on make) CT-MFS, CT-MBS, CT-MVS.2x

This function requires continuous control supply voltage for timing. Applying control supply voltage to terminals **A1-A2**, energizes the star contactor connected to terminals **15-18** and begins the set starting time t_1 . The green LED flashes during timing. When the starting time is complete, the first c/o contact de-energizes the star contactor. Now, the fixed transition time t_2 of 50 ms starts. When the transition time is complete, the second c/o contact energizes the delta contactor connected to terminals **25-28**. The delta contactor remains energized as long as control supply voltage is applied to the unit.

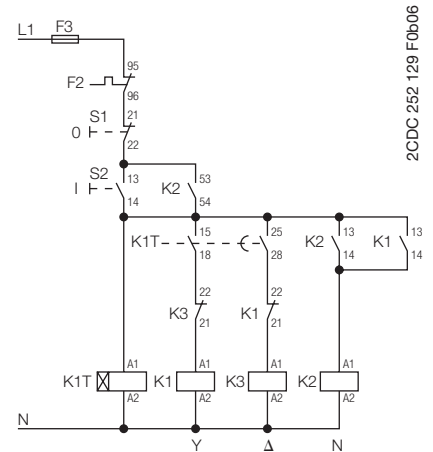
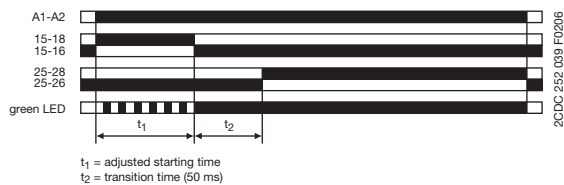

Control circuit diagram

△ Star-delta change-over (Star-delta starting) CT-SDS

This function requires continuous control supply voltage for timing. Applying control supply voltage to terminals **A1-A2**, energizes the star contactor connected to terminals **17-18** and begins the set starting time t_1 . The green LED flashes during timing. When the starting time is complete, the first output contact de-energizes the star contactor. Now, the fixed transition time t_2 of 50 ms starts. When the transition time is complete, the second output contact energizes the delta contactor connected to terminals **17-28**. The delta contactor remains energized as long as control supply voltage is applied to the unit.

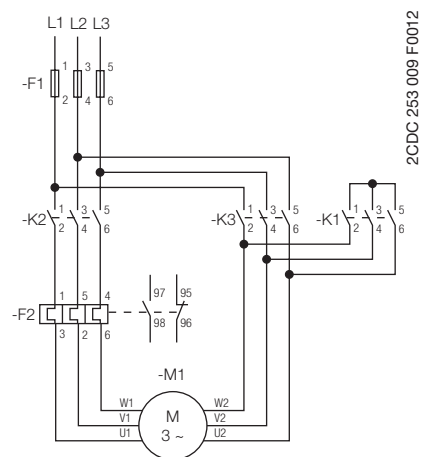
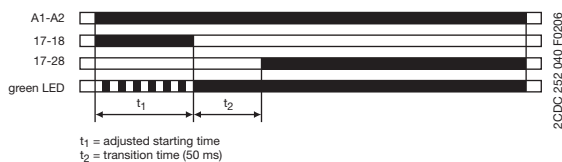

Power circuit diagram

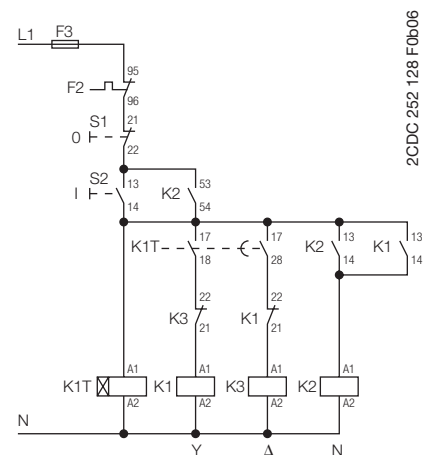

Control circuit diagram

CT-S range

Connection diagrams

1

CT-MVS.21

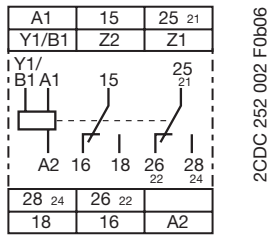

A1-A2 Supply: 24-240 V AC/DC

15-16/18 1. c/o contact
25-26/28 2. c/o contact
21-22/24 2. c/o contact as instantaneous contact

A1-Y1/B1 Control input
Z1-Z2 Remote potentiometer connection

CT-MVS.22

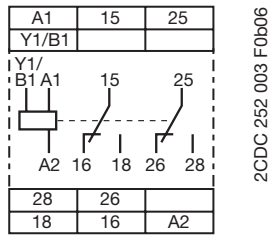

A1-A2 Supply: 24-48 V DC or 24-240 V AC

15-16/18 1. c/o contact
25-26/28 2. c/o contact

A1-Y1/B1 Control input

CT-MVS.23

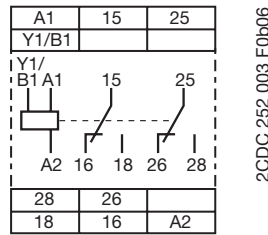

A1-A2 Supply: 380-440 V AC

15-16/18 1. c/o contact
25-26/28 2. c/o contact

A1-Y1/B1 Control input

CT-MVS.12

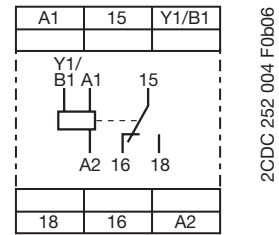

A1-A2 Supply: 24-48 V DC or 24-240 V AC

15-16/18 1. c/o contact

A1-Y1/B1 Control input

CT-MXS.22

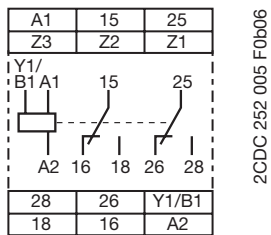

A1-A2 Supply: 24-48 V DC or 24-240 V AC

15-16/18 1. c/o contact
25-26/28 2. c/o contact

A1-Y1/B1 Control input
Z1-Z2 Remote potentiometer connection
Z3-Z2 Remote potentiometer connection

CT-MFS.21

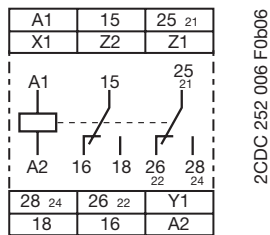

A1-A2 Supply: 24-240 V AC/DC

15-16/18 1. c/o contact
25-26/28 2. c/o contact
21-22/24 2. c/o contact as instantaneous contact

Y1-Z2 Control input
X1-Z2 Control input
Z1-Z2 Remote potentiometer connection

CT-MBS.22

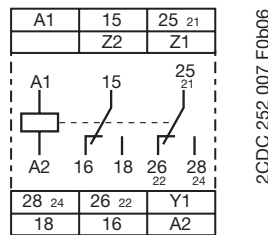

A1-A2 Supply: 24-48 V DC or 24-240 V AC

15-16/18 1. c/o contact
25-26/28 2. c/o contact
21-22/24 2. c/o contact as instantaneous contact

Y1-Z2 Control input
Z1-Z2 Remote potentiometer connection

CT-WBS.22

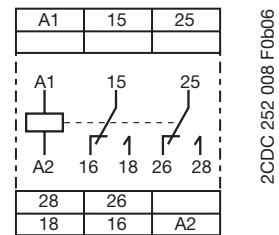

A1-A2 Supply: 24-48 V DC or 24-240 V AC

15-16/18 1. c/o contact
25-26/28 2. c/o contact

CT-ERS.21

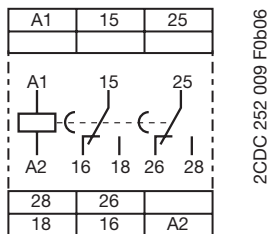

A1-A2 Supply: 24-240 V AC/DC

15-16/18 1. c/o contact
25-26/28 2. c/o contact

CT-ERS.22

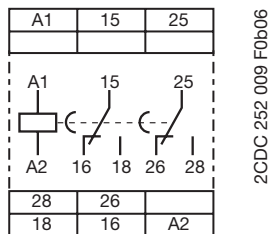

A1-A2 Supply: 24-48 V DC or 24-240 V AC

15-16/18 1. c/o contact
25-26/28 2. c/o contact

CT-ERS.12

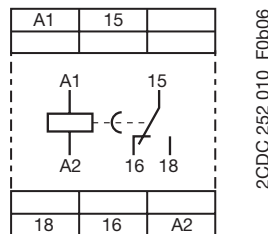

A1-A2 Supply: 24-48 V DC or 24-240 V AC

15-16/18 1. c/o contact

CT-S range

Connection diagrams

CT-APS.21

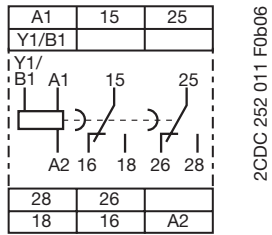

A1-A2 Supply: 24-240 V AC/DC
 15-16/18 1. c/o contact
 25-26/28 2. c/o contact
 A1-Y1/B1 Control input

CT-APS.22

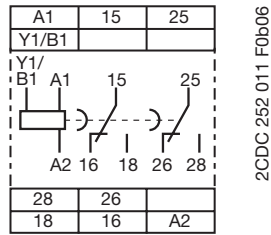

A1-A2 Supply: 24-48 V DC or 24-240 V AC
 15-16/18 1. c/o contact
 25-26/28 2. c/o contact
 A1-Y1/B1 Control input

CT-APS.12

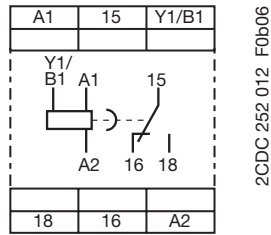

A1-A2 Supply: 24-48 V DC or 24-240 V AC
 15-16/18 1. c/o contact
 A1-Y1/B1 Control input

CT-AHS.22

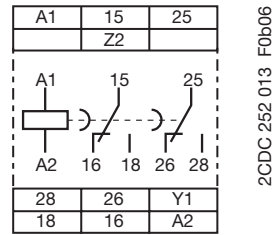

A1-A2 Supply: 24-48 V DC or 24-240 V AC
 15-16/18 1. c/o contact
 25-26/28 2. c/o contact
 Y1-Z2 Control input

CT-ARS.11

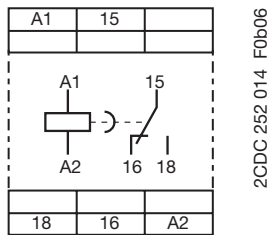

A1-A2 Supply: 24-240 V AC/DC
 15-16/18 1. c/o contact

CT-ARS.21

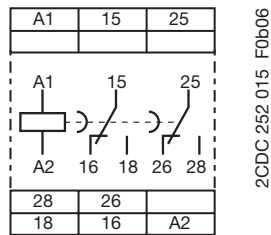

A1-A2 Supply: 24-240 V AC/DC
 15-16/18 1. c/o contact
 25-26/28 2. c/o contact

CT-VBS.17

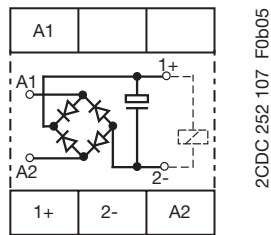

A1-A2 Supply: 110-127 V AC
 1+ - 2- Contactor coil

CT-VBS.18

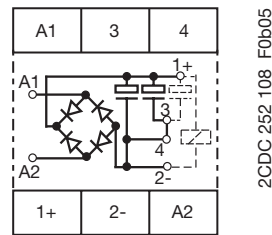

A1-A2 Supply: 200-240 V AC
 1+ - 2- Contactor coil
 3-4 Jumper for setting the time delay (see time delay diagram)

CT-SDS.22

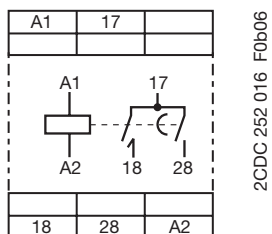

A1-A2 Supply: 24-48 V DC or 24-240 V AC
 17-18 1. n/o contact
 17-28 2. n/o contact

CT-SDS.23

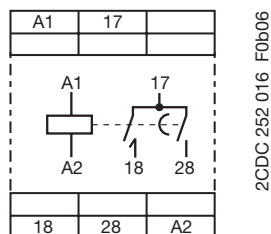

A1-A2 Supply: 380-440 V AC
 17-18 1. n/o contact
 17-28 2. n/o contact

CT-S range

Connection diagrams

1

□ CT-IRS.16

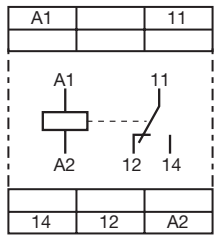

2CDC 252 123 F0b05

A1-A2 Supply: 24 AC/DC

11-12/14 1. c/o contact

□ CT-IRS.14

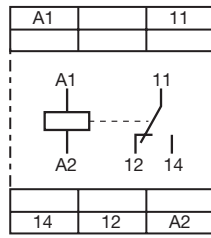

2CDC 252 123 F0b05

A1-A2 Supply: 110-240 V AC

11-12/14 1. c/o contact

□ CT-IRS.26

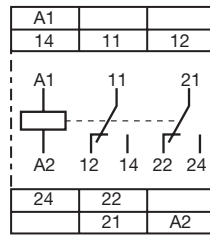

2CDC 252 124 F0b05

A1-A2 Supply: 24 AC/DC

11-12/14 1. c/o contact
 21-22/24 2. c/o contact

□ CT-IRS.24

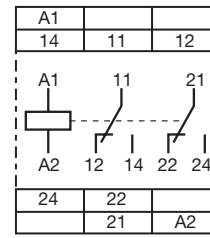

2CDC 252 124 F0b05

A1-A2 Supply: 110-240 V AC

11-12/14 1. c/o contact
 21-22/24 2. c/o contact

□ CT-IRS.26G (gold-plated cont.)

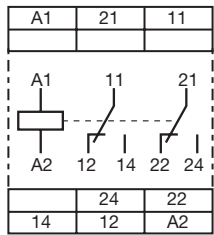

2CDC 252 125 F0b05

A1-A2 Supply: 24 AC/DC

11-12/14 1. c/o contact
 21-22/24 2. c/o contact

□ CT-IRS.24G (gold-plated cont.)

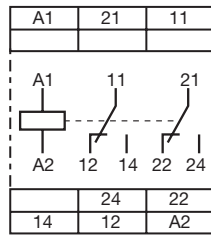

2CDC 252 125 F0b05

A1-A2 Supply: 110-240 V AC

11-12/14 1. c/o contact
 21-22/24 2. c/o contact

□ CT-IRS.36

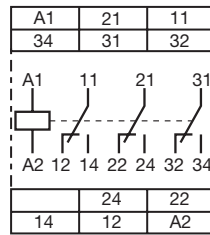

2CDC 252 035 F0b08

A1-A2 Supply: 24 V AC/DC

11-12/14 1. c/o contact
 21-22/24 2. c/o contact
 31-32/34 3. c/o contact

□ CT-IRS.35

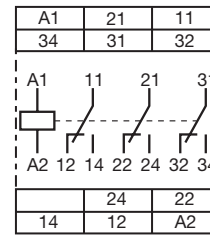

2CDC 252 035 F0b08

A1-A2 Supply: 220-240 V AC

11-12/14 1. c/o contact
 21-22/24 2. c/o contact
 31-32/34 3. c/o contact

CT-S range

Technical data

Data at $T_a = 25\text{ °C}$ and rated values, unless otherwise indicated

		CT-S
Input circuit - Supply circuit		
Rated control supply voltage U_s	CT-xxx.x1	24-240 V AC/DC
	CT-xxx.x2	24-48 V DC, 24-240 V AC
	CT-xxx.x3	380-440 V AC
	CT-xxx.x4	110-240 V AC
	CT-xxx.x5	220-240 V AC
	CT-xxx.x6	24 V AC/DC
	CT-xxx.x7	100-127 V AC or 110 V DC
	CT-xxx.x8	200-240V AC/DC
Rated control supply voltage U_s tolerance		-15...+10 %
Rated frequency		DC or 50/60 Hz
Frequency range AC		47-63 Hz
Typical current / power consumption		depending on device, see data sheet
Power failure buffering time	24 V DC	min. 15 ms
	230/400 V AC	min. 20 ms
Input circuit - Control circuit		
Kind of triggering	CT-MVS, CT-MXS, CT-APS	voltage-related triggering
Control input, Control function	A1-Y1/B1	start timing external
Parallel load / polarized		yes / no
Maximum cable length to the control input		50 m - 100 pF/m
Minimum control pulse length		20 ms
Control voltage potential		see rated control supply voltage
Current consumption of the control input	24 V DC	1.2 mA
	230 V AC	8 mA
	400 V AC	6 mA
Kind of triggering	CT-MFS, CT-MBS, CT-AHS	volt-free triggering
Control input, Control function	Y1-Z2	start timing external
	X1-Z2	pause timing / accumulative functions (CT-MFS)
Maximum switching current in the control circuit		1 mA
Maximum cable length to the control input		50 m - 100 pF/m
Minimum control pulse length		20 ms
No-load voltage at the control inputs		10-40 V DC
Remote potentiometer		
Remote potentiometer connections, Resistance value	Z1-Z2	50 k Ω (CT-MFS, CT-MBS, CT-MVS.21, CT-MXS)
	Z3-Z2	50 k Ω (CT-MXS)
Maximum cable length to remote potentiometer		2 x 25 m, shielded with 100 pF/m
Shield connection		Z2
Timing circuit		
Time ranges	10 time ranges 0.05 s - 300 h	1.) 0.05-1 s 2.) 0.15-3 s 3.) 0.5-10 s 4.) 1.5-30 s 5.) 5-100 s 6.) 15-300 s 7.) 1.5-30 min 8.) 15-300 min 9.) 1.5-30 h 10.) 15-300 h
	7 time ranges 0.05 s - 10 min (CT-SDS, CT-ARS)	1.) 0.05-1 s 2.) 0.15-3 s 3.) 0.5-10 s 4.) 1.5-30 s 5.) 5-100 s 6.) 15-300 s 7.) 0.5-10 min
Recovery time	24-240 V AC/DC	<50 ms
	24-48 V DC, 24-240 V AC	< 80 ms
	380-440 V AC	< 60 ms
Accuracy within the rated control supply voltage tolerance		$\Delta t < 0.004\%$ / V
Accuracy within the temperature range		$\Delta t < 0.03\%$ / °C
Repeat accuracy (constant parameters)		< $\pm 0.2\%$
Star-delta transition time		fixed 50 ms (CT-SDS, CT-MBS, CT-MFS, CT-MVS.2x)
Star-delta transition time tolerance		± 2 ms
Minimum energizing time		100 ms (CT-ARS)
Formatting time ¹⁾		5 min (CT-ARS)

¹⁾ prior to first commissioning and after a six-month stop in operation

CT-S range

Technical data

1

Indication of operational states			
Control supply voltage / timing	U/T: green LED	: control supply voltage applied / : timing	
Control supply voltage	U: green LED	: control supply voltage applied	
Relay state	R, R1, R2: yellow LED	: output relay energized	
Output circuit			
Kind of output	15-16/18	relay, 1 c/o contact	
	15-16/18; 25-26/28	relay, 2 c/o contacts	
	15-16/18; 25(21)-26(22)/28(24)	relay, 2 c/o contacts, 2nd c/o contact selectable as inst. contact	
	17-18; 17-28	relay, 2 n/o contacts (CT-SDS)	
Contact material		Cd-free, on request	
Rated operational voltage U_o	IEC/EN 60947-1	250 V	
Minimum switching voltage / minimum switching current		12 V / 10 mA (CT-IRS.2xG: 10 mV / 10 μ A)	
Maximum switching voltage / maximum switching current		see load limit curves (CT-IRS.2xG: 10 V / 200 mA)	
Rated operational current I_o	AC12 (resistive) at 230 V	4 A	
(IEC/EN 60947-5-1)	AC15 (inductive) at 230 V	3 A	
	DC12 (resistive) at 24 V	4 A	
	DC13 (inductive) at 24 V	2 A (CT-ARS; 1.5 A)	
AC rating (UL 508)	Utilization category (Control Circuit Rating Code)	B 300	
	max. rated operational voltage	300 V AC	
	Maximum continuous thermal current at B300	5 A	
	max. making/breaking apparent power at B300	3600 VA / 360 VA	
Mechanical lifetime		30 x 10 ⁶ switching cycles	
Electrical lifetime	at AC12, 230 V, 4 A	0.1 x 10 ⁶ switching cycles	
Max. fuse rating to achieve short-circuit protection	n/c contact	6 A fast-acting	
(IEC/EN 60947-5-1)	n/o contact	10 A fast-acting	
General data ²⁾			
MTBF		on request	
Duty time		100%	
Dimensions (W x H x D)	product dimensions	22.5 x 85.6 x 103.7 mm (0.89 x 3.37 x 4.08 in)	
	packaging dimensions	97 x 109 x 30 mm (3.82 x 4.29 x 1.18 in)	
Weight		depending on device, see ordering details	
Mounting		DIN rail (IEC/EN 60715), snap-on mounting without any tool	
Mounting position		any	
Minimum distance to other units	vertical / horizontal	not necessary / not necessary	
Material of housing		UL 94 V-0	
Degree of protection	housing / terminals	IP50 / IP20	
Electrical connection ²⁾			
Wire size	fine-strand with(out) wire end ferrule	Screw connection technology	Easy Connect Technology (Push-in)
		1 x 0.5-2.5 mm ² (1 x 20-14 AWG) 2 x 0.5-1.5 mm ² (2 x 20-16 AWG)	2 x 0.5-1.5 mm ² (2 x 20-16 AWG)
	rigid	1 x 0.5-4 mm ² (1 x 20-12 AWG) 2 x 0.5-2.5 mm ² (2 x 20-14 AWG)	2 x 0.5-1.5 mm ² (2 x 20-16 AWG)
Stripping length		8 mm (0.32 in)	-
Tightening torque		0.6-0.8 Nm (5.31-7.08 lb.in)	-

²⁾Data for all references 1SVR 730 xxx xxx and 1SVR 740 xxx xxx. For devices with 1SVR 430 xxx xxx please refer to the data sheet.

CT-S range

Technical data

1

Environmental data

Ambient temperature ranges	operation / storage	-25...+60 °C / -40...+85 °C, -40...+60 °C / -40...+85 °C (CT-MVS.21, CT-MFS.21, CT-ERS.21, CT-APS.21)
Damp heat (cyclic) (IEC/EN 60068-2-30)		6 x 24 h cycle, 55 °C, 95 % RH
Vibration, sinusoidal (IEC/EN 60068-2-6)	functioning resistance	40 m/s ² , 10-58/60-150 Hz 60 m/s ² , 10-58/60-150 Hz, 20 cycles
Vibration, seismic (IEC/EN 60068-3-3)	functioning	20 m/s ²
Shock, half-sine (IEC/EN 60068-2-27)	functioning resistance	100 m/s ² , 11 ms, 3 shocks/direction 300 m/s ² , 11 ms, 3 shocks/direction

Isolation data

Rated insulation voltage U _i	input circuit / output circuit	500 V
	output circuit 1 / output circuit 2	300 V
Rated impulse withstand voltage U _{imp} between all isolated circuits	VDE 0110, IEC/EN 60664	4 kV; 1.2/50 µs
Power-frequency withstand voltage test between all isolated circuits (test voltage)	routine test type test	2.0 kV, 50 Hz, 1 s 2.5 kV, 50 Hz, 1 min
Basic insulation (IEC/EN 61140)	input circuit / output circuit	500 V
Protective separation (IEC/EN 61140; EN 50178)	input circuit / output circuit	250 V
Pollution degree (IEC/EN 60664-1)		3
Overvoltage category (IEC/EN 60664-1)		III

Standards

Product standard	IEC 61812-1, EN 61812-1 + A11, DIN VDE 0435 part 2021
Low Voltage Directive	2006/95/EC
EMC Directive	2004/108/EC
RoHS Directive	2002/95/EC

Electromagnetic compatibility

Interference immunity to		IEC/EN 61000-6-1, IEC/EN 61000-6-2
electrostatic discharge	IEC/EN 61000-4-2	Level 3, 6 kV / 8 kV
radiated, radio-frequency electromagnetic field	IEC/EN 61000-4-3	Level 3, 10 V/m (1 GHz) 3 V/m (2 GHz) 1 V/m (2.7 GHz)
electrical fast transient / burst	IEC/EN 61000-4-4	Level 3, 2 kV / 5 kHz
surge	IEC/EN 61000-4-5	Level 4, 2 kV A1-A2
conducted disturbances, induced by radio-frequency fields	IEC/EN 61000-4-6	Level 3, 10 V
harmonics and interharmonics	IEC/EN 61000-4-13	Class 3
Interference emission		IEC/EN 61000-6-3, IEC/EN 61000-6-4
high-frequency radiated	IEC/CISPR 22, EN 55022	Class B
high-frequency conducted	IEC/CISPR 22, EN 55022	Class B

„Approvals and marks“ see page 1/4.

CT-S range

Technical diagrams

1

Technical diagrams

Load limit curves

AC load (resistive)

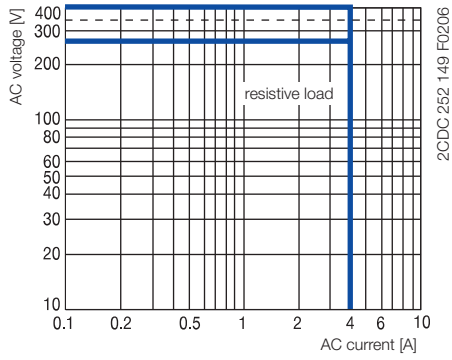

DC load (resistive)

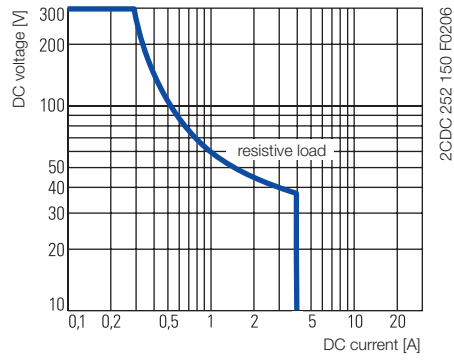

Derating factor F
for inductive AC load

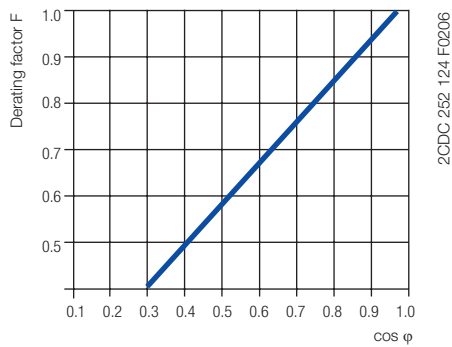

Contact lifetime

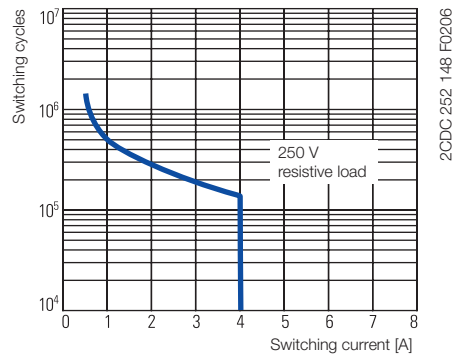

CT-S range

Wiring notes, Dimensional drawings

Wiring notes

Control inputs (volt-free triggering)

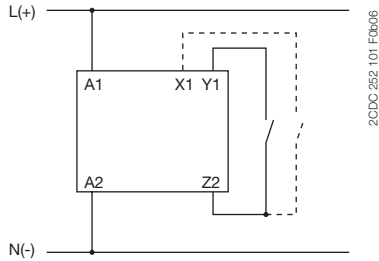

Triggering of the control inputs (volt-free) with a proximity switch (3 wire)

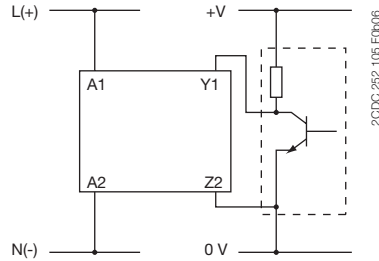

Control inputs (voltage-related triggering)

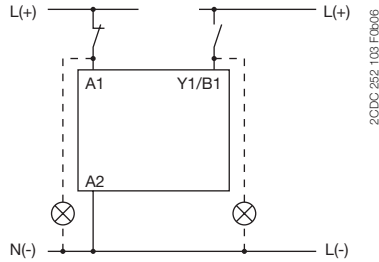
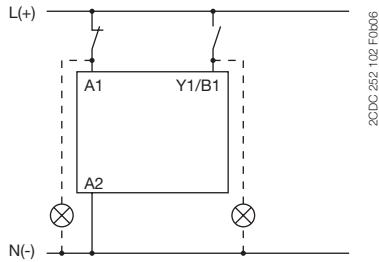

The control input **Y1/B1** is triggered with electric potential against **A2**. It is possible to use the control supply voltage from terminal **A1** or any other voltage within the rated control supply voltage range.

Remote potentiometer

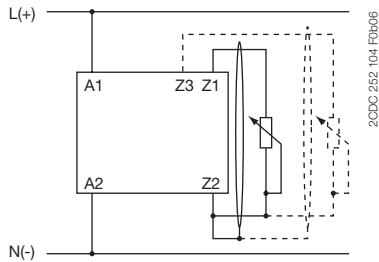

Dimensional drawing

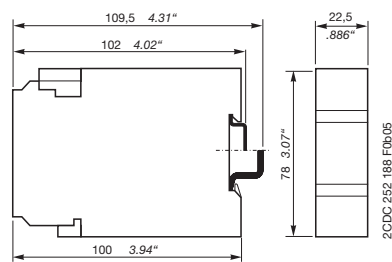

1SVR 430 xxx xxx

Dimensions in mm and inches

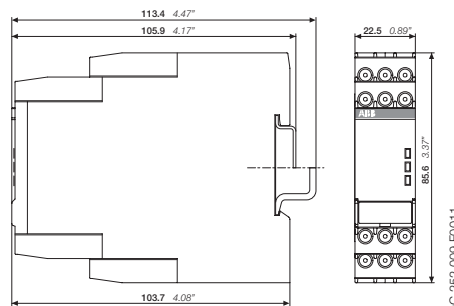

1SVR 730 xxx xxx, 1SVR 740 xxx xxx

Measuring and monitoring relays

Product group picture

2



Measuring and monitoring relays

Table of contents

Measuring and monitoring relays	
Product group picture	1
Table of contents	2
Benefits and advantages	3
Monitoring features and application ranges	5
Approvals and marks	7
Current and voltage monitoring relays, single-phase	9
Three-phase monitoring relays	27
Grid feeding monitoring relays - Voltage and frequency monitoring functions	49
Insulation monitoring relays for unearthed supply systems	63
Motor load monitoring relays	77
Motor control and protection	83
Thermistor motor protection relays	89
Temperature monitoring relays	99
Liquid level monitors and controls	111
Contact protection relays	125
Sensor interface relays	131
Cycle monitoring relay with watchdog function	137
General technical data, Accessories, Current transformers	143

Measuring and monitoring relays

Benefits and advantages

CM-N range: Multifunctional



- 45 mm wide housing
- Output contacts: 2 c/o (SPDT) contacts
- Continuous voltage range (24-240 V AC/DC) or single-supply
- Setting and operation via front-face operating controls
- Adjustment of threshold values and switching hysteresis via direct reading scale
- Adjustable time delays
- Integrated and snap-fitted front-face marker label
- Sealable transparent cover (accessory)

CM-S range: Universal and multifunctional

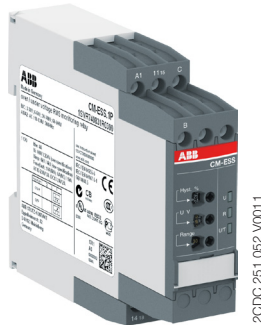

- Only 22.5 mm wide housing
- Output contacts: 1 or 2 c/o (SPDT) contacts
- One supply voltage range or supplied by measuring circuit
- Setting and operation via front-face operating controls
- Adjustment of threshold values and switching hysteresis via direct reading scale
- Integrated and snap-fitted front-face marker
- Snap-on housing: The relays can be placed on a DIN rail tool-free - just snap it on or remove it tool-free
- Sealable transparent cover (accessory)

CM-E range: Economy



- Only 22.5 mm wide housing
- Output contacts: 1 c/o contact or 1 n/o contact
- One supply voltage range
- One monitoring function
- Cost-efficient solution for OEM applications
- Preset monitoring ranges

ABB's measuring and monitoring relays in a new housing

Benefits at a glance

Easy Connect Technology

New options:

Additionally to the existing well established screw connections a new innovative connection technology can be offered: Easy Connect Technology with push-in terminals.

Tool-free wiring:

The push-in terminals can be wired with rigid or fine stranded wires with wire end ferrules totally tool-free. The connection direction is exactly the same as the screw version.

Higher utility class:

The Easy Connect Technology provides excellent vibration resistance with gas tight push-in terminals – the right solution for harsh environment.

Extended features

Flammability:

The plastic housing material used meets the requirements for the highest flammability class. (UL94 V-0 rated)

Look and feel:

The new housing fits perfectly with ABB's control products offer.

Measuring and monitoring relays

Benefits and advantages

Combination screws for CM-E range ①

Easy tightening and release of the connection screws with pozidrive, pan- or crosshead screwdriver.

Safety ②

The „real distance“ is hidden. The clearance and the creepage distances of our products exceed international standards and substantially increase the safety of our products.

Easy Connect Technology ③

Tool-free wiring and excellent vibration resistance. Push-in terminals provide connection of wires up to 2 x 0.5 - 1.5 mm² (2 x 20 -16 AWG), rigid or fine-strand with or without wire end ferrules. The extended type designators for products with push-in terminals are indicated by a P following the extended type designator e.g. CM-xxS.xxP.

Double-chamber cage connection terminals ④

Double-chamber cage connection terminals provide connection of wires up to 2 x 0,5-2.5 mm² (2 x 20-14 AWG) rigid or fine-strand, with or without wire end ferrules. Potential distribution does not require additional terminals. The extended type designators for products with double-chamber cage connection terminals are indicated by a S following the extended type designator e.g. CM-xxS.xxS.

LED's for status indication ⑤

All actual operational states are displayed by front-face LEDs, thus simplifying commissioning and troubleshooting.

Integrated marker label ⑥

Integrated marker labels allow the product to be marked quickly and simply. No additional marker labels are required.

Sealable transparent cover ⑦

Protection against unauthorized changes of time and threshold values. Available as an accessory.

Snap-On housing ⑧

Tool-free DIN rail installation and deinstallation of the monitoring relay.

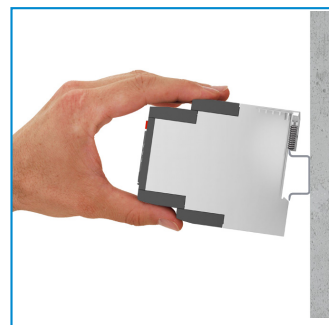
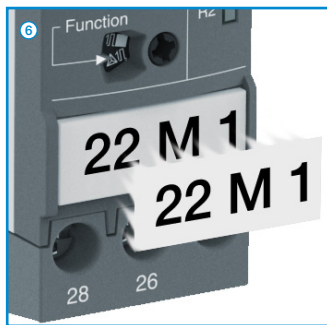
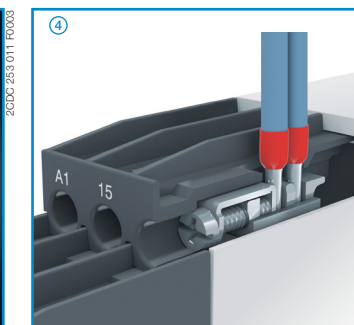
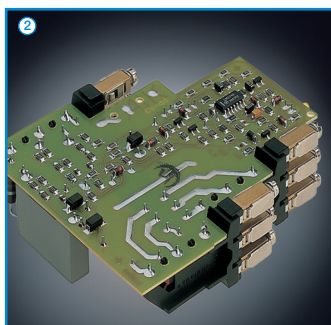
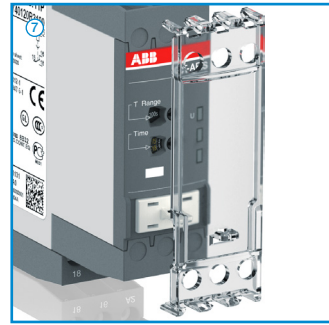
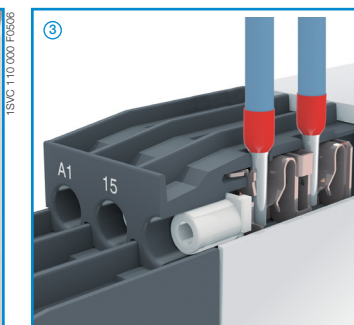

Measuring and monitoring relays

Monitoring features and application ranges

Single-phase current and voltage monitoring

- Over- or undercurrent monitoring CM-SRS and CM-SRS.M
- Over- and undercurrent monitoring CM-SFS
- Over- or undervoltage monitoring CM-ESS and CM-ESS.M
- Over- and undervoltage monitoring CM-EFS

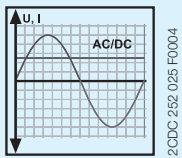

Current monitoring

- Monitoring of motor current consumption
- Monitoring of lighting installations and heating circuits
- Monitoring of hoisting gear and transportation equipment overload
- Monitoring of locking devices, electromechanical brake gear and locked rotor

Voltage monitoring

- Speed monitoring of DC motors
- Monitoring of battery voltages and other supply networks
- Monitoring of upper and lower voltage threshold values

Insulation monitoring

- For electrically isolated AC systems: CM-IWS.2
- For electrically isolated AC, DC and mixed AC/DC systems: CM-IWS.1, CM-IWN.1 and especially for solar applications:
 - ≤ 500 μF: CM-IWN.4
 - ≤ 1000 μF: CM-IWN.5
 - ≤ 2000 μF: CM-IWN.6

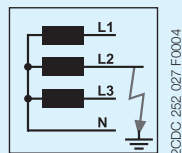

- Monitoring of electrically isolated supply mains for insulation resistance failure
- Detection of initial faults
- Protection against earth faults

Motor load monitoring

CM-LWN monitoring relays load states of single- and three-phase asynchronous motors.

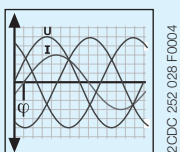

- Detection of V-belt breaking
- Motor protection against overload
- Monitoring of filters for clogging
- Protection of pumps against dry running
- Detection of high pressure in conduit systems
- Monitoring for dulling blades in sawing and cutting machines

Three-phase monitoring

- Phase failure CM-PBE
- Over- and undervoltage CM-PVE
- Phase sequence and phase failure CM-PFE and CM-PFS
- Phase sequence and phase failure, over- and undervoltage CM-PSS.xx and CM-PVS.xx
- Phase sequence and phase failure, unbalance CM-PAS.xx
- Phase sequence and phase failure, unbalance, over- and undervoltage CM-MPS.xx and CM-MPN.xx
- Over- and undervoltage, over- and underfrequency CM-UFS.1

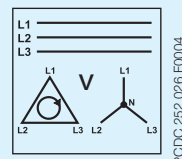

Three-phase voltage monitoring

- Voltage monitoring of mobile three-phase equipment
- Protection of personnel and installations against phase reversal
- Monitoring of the supply voltage to machines and installations
- Protection of equipment against damage caused by unstable supply voltage
- Switching to emergency or auxiliary supply
- Protection of motors against damage caused by unbalanced phase voltages and phase loss
- Automatic connection & disconnection of decentralised power stations to the grid

Grid feeding monitoring relays

The CM-UFx range monitors all voltage and frequency parameters in a grid and ensures the safe feeding of decentral produced electrical energy into the grid.

- Monitoring of the voltage with up to 2 thresholds for over- and undervoltage
- Monitoring of the frequency with up to 2 thresholds for over- and underfrequency
- Optional ROCOF (rate of change of frequency) and vector shift
- Acc. to national grid feeding standards such as CEI 0-21, VDE AR-N 4105 etc.

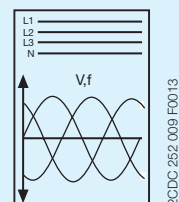

Thermistor motor protection

CM-MSE, CM-MSS and CM-MSN provide full protection of motors with integrated PTC resistor sensors.

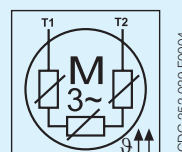

- Protection of motors against thermal overload, e. g. caused by insufficient cooling, heavy load starting conditions, undersized motors, etc.

Measuring and monitoring relays

Monitoring features and application ranges

Liquid level monitoring and control

CM-ENE, CM-ENS and CM-ENN for control and regulation of liquid levels and ratios of mixtures of conductive fluids.

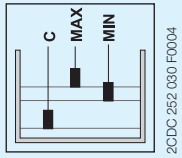

2CDC 252 030 F0004

- Protection of pumps against dry running
- Protection against container overflow
- Control of liquid levels
- Detection of leaks
- Control of mixing ratios

Cycle monitoring

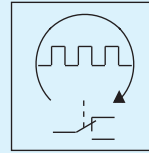

2CDC 252 036 F0004

- External monitoring of the correct function of programmable logic controllers (plc) and industrial pcs (ipc)

Contact protection, sensor evaluation

The CM-KRN protects sensitive control contacts from excessive loads and can store switch positions. The CM-SIS supplies and evaluates NPN and PNP sensors.

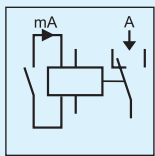

2CDC 252 031 F0004

- Storage of the switching states of bouncing contacts
- Amplification of the switch state information of sensitive contacts
- Supply and evaluation of NPN or PNP sensors

Temperature monitoring

Acquisition, messaging and regulation of temperatures of solid, liquid and gaseous media in processes and machines

- with CM-TCS via PT100 sensor
- with C512 and C513 with PT100, PT1000, KTY83, KTY84 or NTC sensors

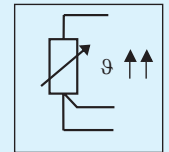

2CDC 252 032 F0004

- Motor and system protection
- Control panel temperature monitoring
- Frost monitoring
- Temperature limits for process variables, e.g. in the packing or electroplating industry
- Control of systems and machines like heating, air-conditioning and ventilation systems, solar collectors, heat pumps or hot water supply systems
- Monitoring of servomotors with KTY sensors
- Bearing and gear oil monitoring
- Coolant monitoring

Measuring and monitoring relays

Approvals and marks

2

■ existing □ pending		Current and voltage monitoring, single-phase							Three-phase monitoring																
		CM-SRS.1S/P	CM-SRS.2S	CM-SRS.MS/P	CM-SFS.2S/P	CM-ESS.2S	CM-ESS.MS/P	CM-EFS.2S/P	CM-PBE	CM-PVE	CM-PFE	CM-PFS.S/P	CM-PSS.x1S/P	CM-PVS.x1S/P	CM-PAS.x1S/P	CM-MPS.x1S/P	CM-MPS.x3S/P	CM-MPN.52S/P	CM-MPN.62S/P	CM-MPN.72S/P					
Approvals																									
UL 508, CAN/CSA C22.2 No.14	■	■	■	■	■	■	■	■	■	■	■	■	■	■	■	■	■	■	■	■	■	■	■	■	■
GL	□	□	□	□	□	□	□	□	□	□	□	□	□	□	□	□	□	□	□	□	□	□	□	□	□
GOST	■ ¹⁾	■ ¹⁾	■ ¹⁾	■ ¹⁾	■ ¹⁾	■ ¹⁾	■ ¹⁾	■ ¹⁾	■ ¹⁾	■ ¹⁾	■ ¹⁾	■ ¹⁾	■ ¹⁾	■ ¹⁾	■ ¹⁾	■ ¹⁾	■ ¹⁾	■ ¹⁾	■ ¹⁾	■ ¹⁾	■ ¹⁾	■ ¹⁾	■ ¹⁾	■ ¹⁾	■ ¹⁾
EAC	■	■	■	■	■	■	■	■	■	■	■	■	■	■	■	■	■	■	■	■	■	■	■	■	■
CB scheme	■	■	■	■	■	■	■	■	■	■	■	■	■	■	■	■	■	■	■	■	■	■	■	■	■
CCC	■	■	■	■	■	■	■	■	■	■	■	■	■	■	■	■	■	■	■	■	■	■	■	■	■
RMRS	■	■	■	■	■	■	■	■	■	■	■	■	■	■	■	■	■	■	■	■	■	■	■	■	■
Rail applications ²⁾	■	■	■	■	■	■	■	■	■	■	■	■	■	■	■	■	■	■	■	■	■	■	■	■	■
Marks																									
CE	■	■	■	■	■	■	■	■	■	■	■	■	■	■	■	■	■	■	■	■	■	■	■	■	■
C-Tick	■	■	■	■	■	■	■	■	■	■	■	■	■	■	■	■	■	■	■	■	■	■	■	■	■

■ existing □ pending		Insulation monitoring relays for ungrounded supply mains					Motor load monitoring		Temperature monitoring			Contact protection, sensor interface		Grid feeding monitoring relays			
		CM-IWS.2S/P	CM-IWS.1S/P	CM-IWN.1S/P	CM-IWN.4,5,6.S/P	CM-IWN.S/P	CM-LWN		CM-TCS.xS/P	C512	C513	CM-KRN	CM-SIS		CM-UFS.1	CM-UFD.M21	CM-UFD.M22
Approvals																	
UL 508, CAN/CSA C22.2 No.14	■	■	■	■	■	■	■	■	■	■	■	■	■	■	■	■	■
GL	■	■	■	■	■	■	■	■	■	■	■	■	■	■	■	■	■
GOST	■ ¹⁾	■ ¹⁾	■ ¹⁾	■ ¹⁾	■ ¹⁾	■ ¹⁾	■ ¹⁾	■ ¹⁾	■ ¹⁾	■ ¹⁾	■ ¹⁾	■ ¹⁾	■ ¹⁾	■ ¹⁾	■ ¹⁾	■ ¹⁾	■ ¹⁾
CB scheme	■	■	■	■	■	■	■	■	■	■	■	■	■	■	■	■	■
CCC	■	■	■	■	■	■	■	■	■	■	■	■	■	■	■	■	■
RMRS	■	■	■	■	■	■	■	■	■	■	■	■	■	■	■	■	■
Rail applications ²⁾	■	■	■	■	■	■	■	■	■	■	■	■	■	■	■	■	■
DEKRA CEI 0-21																	■
VDE-AR-N 4105 „Erzeugungsanlagen am Niederspannungsnetz“																	■
BDEW „Erzeugungsanlagen am Mittelspannungsnetz“																	■
Marks																	
CE	■	■	■	■	■	■	■	■	■	■	■	■	■	■	■	■	■
C-Tick	■	■	■	■	■	■	■	■	■	■	■	■	■	■	■	■	■

■ existing □ pending		Cycle monitoring			Thermistor motor protection									Liquid level monitoring					
		CM-WDS			CM-MSE	CM-MSS (1)	CM-MSS (2)	CM-MSS (3)	CM-MSS (4)	CM-MSS (5)	CM-MSS (6)	CM-MSS (7)	CM-MSN	CM-ENE MIN	CM-ENE MAX	CM-ENS	CM-ENS UP/...	CM-ENN	CM-ENN UP/...
Approvals																			
UL 508, CAN/CSA C22.2 No.14	■			■	■	■	■	■	■	■	■	■	■	■	■	■	■	■	■
GL					■	■	■	■	■	■	■	■	■	■	■	■	■	■	■
GOST	■ ¹⁾				■ ¹⁾	■ ¹⁾	■ ¹⁾	■ ¹⁾	■ ¹⁾	■ ¹⁾	■ ¹⁾	■ ¹⁾	■ ¹⁾	■ ¹⁾	■ ¹⁾	■ ¹⁾	■ ¹⁾	■ ¹⁾	■ ¹⁾
EAC	■				■	■	■	■	■	■	■	■	■	■	■	■	■	■	■
II (2) G D, PTB 02 ATEX 3080					■	■	■	■	■	■	■	■	■	■	■	■	■	■	■
CB scheme	■				■	■	■	■	■	■	■	■	■	■	■	■	■	■	■
CCC	■				■	■	■	■	■	■	■	■	■	■	■	■	■	■	■
RMRS	■				■	■	■	■	■	■	■	■	■	■	■	■	■	■	■
Marks																			
CE	■				■	■	■	■	■	■	■	■	■	■	■	■	■	■	■
C-Tick	■				■	■	■	■	■	■	■	■	■	■	■	■	■	■	■

¹⁾ May have been replaced by EAC during the availability of this catalog edition.

²⁾ Applicable in rail application following the latest standards for rail applications: NF F 16-101/102 (I2/F2 classified), EN 45545 (Hazard Level 3), DIN 5510, EN 50155, IEC 60571. Further information is available in our rail segment brochure 2CDC110084B0201.

³⁾ Version with protective separation without ® approval

Current and voltage monitoring relays, single-phase

Product group picture

2



Current and voltage monitoring relays, single-phase

Table of contents

Current and voltage monitoring relays, single-phase	
Product group picture	9
Table of contents	10
Benefits and advantages	11
Operating controls	12
Selection table - Current monitoring relays	13
Selection table - Voltage monitoring relays	14
Ordering details - Current monitoring relays	15
Ordering details - Voltage monitoring relays	16
Function diagrams	17
Connection diagrams, DIP switches	20
Technical data - Current monitoring relays	22
Technical data - Voltage monitoring relays	24
Notes	26







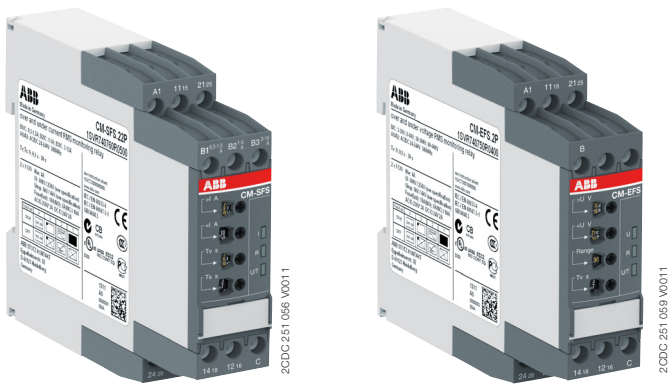







































































Current and voltage monitoring relays, single-phase

Benefits and advantages

2



Characteristics current and voltage monitoring relays

- Monitoring of DC and AC currents: 3 mA to 15 A ¹⁾
- Monitoring of DC and AC voltages from 3 - 600 V
- TRMS measuring principle
- One device includes 3 measuring ranges
- One device includes 4 measuring ranges: 3 - 30 V; 6 - 60 V; 30 - 300 V; 60 - 600 V
- Over- and undercurrent monitoring¹⁾
- Over- and undervoltage monitoring¹⁾
- ON or OFF-delay configurable¹⁾
- Open- or closed-circuit principle configurable¹⁾
- Threshold values for >U and/or <U adjustable¹⁾
- Latching function configurable¹⁾
- Thresholds for >I and/or <I adjustable¹⁾
- Fixed hysteresis of 5 %¹⁾
- Start-up delay T_v adjustable 0; 0.1 - 30 s¹⁾
- Tripping delay T_v adjustable 0; 0.1 - 30 s¹⁾
- 1 x 2 c/o contacts (common signal) or 2 x 1 c/o contact (separate signals for >I and <I) configurable ¹⁾
- 1 x 2 c/o contacts (common signal) or 2 x 1 c/o contact (separate signals for >U and <U) configurable¹⁾
- 22.5 mm width
- 3 LEDs for the indication of operational states
- Approvals / Marks                                        /                                       

¹⁾ depending on device

²⁾ Applicable in rail application following the latest standards for rail applications: NF F 16-101/102 (I2/F2 classified), EN 45545 (Hazard Level 3), DIN 5510, EN 50155, IEC 60571. Further information is available in our rail segment brochure 2CDC110084B0201.

Current monitoring, single-phase

The ABB current monitoring relays CM-SRS.xx reliably monitor the occurrence of currents that exceed or fall below the selected threshold value. The functions overcurrent or undercurrent monitoring can be preselected. Single- and multifunction devices for the monitoring of direct or alternating currents from 3 mA to 15 A are available.

Current window monitoring (I_{min} , I_{max})

The window monitoring relay CM-SFS.2x is available if the application requires the simultaneous monitoring of over- and undercurrents.

Voltage monitoring, single-phase

The ABB voltage monitoring relays CM-SRS.xx are used to monitor direct and alternating voltages within a range of 3-600 V. Over- or undervoltage detection can be preselected.

Voltage window monitoring (U_{min} , U_{max})

For the simultaneous detection of over- and undervoltages, the window monitoring relay CM-EFS.2 can be used.

Current and voltage monitoring relays, single-phase

Operating controls

Current monitoring relays

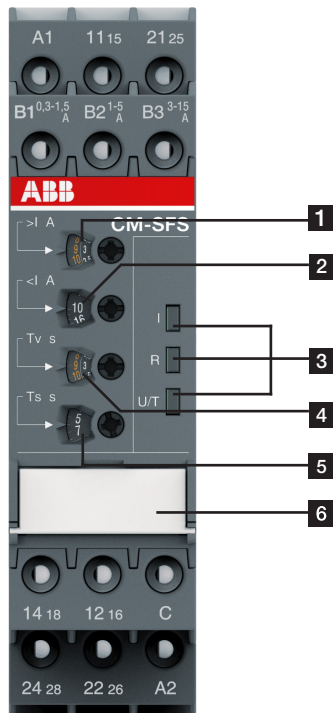

- 1** Adjustment of the threshold value $>I$ for overcurrent
- 2** Adjustment of the threshold value $<I$ for undercurrent
- 3** Indication of operational states
U/T: green LED – control supply voltage/timing
R: yellow LED – relay status
I: red LED – over- / undercurrent
- 4** Adjustment of the tripping delay T_v
- 5** Adjustment of the start-up delay T_s
- 6** DIP switches (see DIP switch functions on page 2/20)
 - ON-delay
 - OFF-delay
 - Closed-circuit principle
 - Open-circuit principle
 - Latching function activated
 - Latching function not activated
 - 2x1 c/o (SPDT) contact
 - 1x2 c/o (SPDT) contacts

Voltage monitoring relays

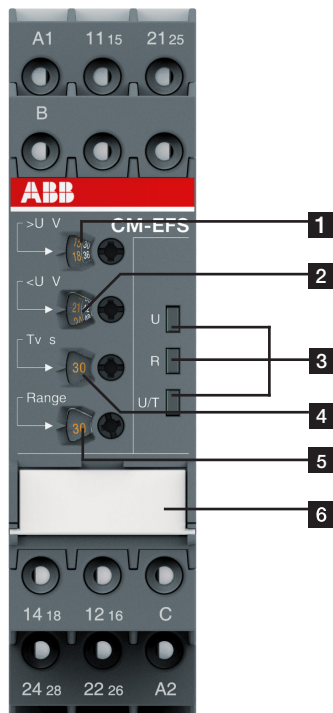

- 1** Adjustment of the threshold value $>U$ for overvoltage
- 2** Adjustment of the threshold value $<U$ for undervoltage
- 3** Indication of operational states
U/T: green LED – control supply voltage/timing
R: yellow LED – relay status
U: red LED – over- / undervoltage
- 4** Adjustment of the tripping delay T_v
- 5** Adjustment of the measuring range
- 6** DIP switches (see DIP switch functions on page 2/20)
 - ON-delay
 - OFF-delay
 - Closed-circuit principle
 - Open-circuit principle
 - Latching function activated
 - Latching function not activated
 - 2x1 c/o (SPDT) contact
 - 1x2 c/o (SPDT) contacts

Current and voltage monitoring relays, single-phase

Selection table - Current monitoring relays



Type	Order number	CM-SRS.11S	CM-SRS.11P	CM-SRS.11S	CM-SRS.11P	CM-SRS.11S	CM-SRS.11P	CM-SRS.12S	CM-SRS.21S	CM-SRS.21P	CM-SRS.21S	CM-SRS.21P	CM-SRS.21S	CM-SRS.21P	CM-SRS.22S	CM-SRS.M1S	CM-SRS.M1P	CM-SRS.M2S	CM-SFS.21S	CM-SFS.21P	CM-SFS.22S	
Rated control supply voltage U_s																						
24 - 240 V AC/DC		■	■					■		■	■				■		■	■	■	■	■	■
110 - 130 V AC				■	■			■			■	■			■							
220 - 240 V AC						■	■		■			■	■			■						
Measuring ranges AC/DC																						
3 - 30 mA		■	■	■	■	■	■		■	■	■	■	■	■								
10 - 100 mA		■	■	■	■	■	■		■	■	■	■	■	■								
0.1 - 1 A		■	■	■	■	■	■		■	■	■	■	■	■								
0.3 - 1.5 A								■	■	■	■	■	■	■								■
1 - 5 A								■	■	■	■	■	■	■								■
3 - 15 A								■	■	■	■	■	■	■								■
Monitoring function																						
Over- or undercurrent		■	■	■	■	■	■	■	■	■	■	■	■	■	■	■	■	■	■	■	■	■
Windows current monitoring																				■	■	■
Latching																				sel	sel	sel
Open circuit or closed circuit principle																				sel	sel	sel
Timing functions for tripping delay																						
ON delay, 0 or 0.1 - 30 s									adj	adj	adj	adj	adj	adj	adj	adj	adj	adj	adj	adj	adj	adj
ON or OFF delay																					sel	sel
Output																						
c/o contact		1	1	1	1	1	1	1	1	2	2	2	2	2	2	2	2	2	2	2	2	2
Connection type																						
Push-in terminals		■	■	■	■	■	■	■	■	■	■	■	■	■								■
Double-chamber cage connection terminals		■		■		■	■	■	■	■	■	■	■	■	■	■	■	■	■	■	■	■

adj: adjustable
sel: selectable

Current and voltage monitoring relays, single-phase

Selection table - Voltage monitoring relays



Type	Order number	1	2	3	4	5	6	7	8	9	10	11	12	13	14		
CM-ESS.1S	1SVR 730 830 R0300																
CM-ESS.1P	1SVR 740 830 R0300																
CM-ESS.1S	1SVR 730 831 R0300																
CM-ESS.1P	1SVR 740 831 R0300																
CM-ESS.1S	1SVR 730 831 R1300																
CM-ESS.1P	1SVR 740 831 R1300																
CM-ESS.2S	1SVR 730 830 R0400																
CM-ESS.2P	1SVR 740 830 R0400																
CM-ESS.2S	1SVR 730 831 R0400																
CM-ESS.2P	1SVR 740 831 R0400																
CM-ESS.2S	1SVR 730 831 R1400																
CM-ESS.2P	1SVR 740 831 R1400																
CM-ESS.MS	1SVR 730 830 R0500																
CM-ESS.MP	1SVR 740 830 R0500																
CM-EFS.2S	1SVR 730 750 R0400																
CM-EFS.2P	1SVR 740 750 R0400																
Rated control supply voltage U_c																	
24 - 240 V AC/DC		■	■					■	■					■	■	■	
110 - 130 V AC				■	■					■	■						
220 - 240 V AC						■	■					■	■				
Measuring ranges AC/DC																	
3 - 30 V		■	■	■	■	■	■	■	■	■	■	■	■	■	■	■	
6 - 60 V		■	■	■	■	■	■	■	■	■	■	■	■	■	■	■	
30 - 300 V		■	■	■	■	■	■	■	■	■	■	■	■	■	■	■	
60 - 600 V		■	■	■	■	■	■	■	■	■	■	■	■	■	■	■	
Monitoring function																	
Over- or undervoltage		■	■	■	■	■	■	■	■	■	■	■	■	■	■	■	
Windows voltage monitoring															■	■	
Latching														sel	sel	sel	sel
Open circuit or closed circuit principle														sel	sel	sel	sel
Timing functions for tripping delay																	
ON delay, 0 or 0.1 - 30 s								adj	adj	adj	adj	adj	adj	adj	adj	adj	
ON or OFF delay																sel	sel
Output																	
c/o contact		1	1	1	1	1	1	2	2	2	2	2	2	2	2	2	
Connection type																	
Push-in terminals			■		■		■		■		■		■		■	■	
Double-chamber cage connection terminals		■		■		■		■		■		■		■		■	

adj: adjustable
sel: selectable

Current and voltage monitoring relays, single-phase



























Ordering details - Current monitoring relays

2

Description

The CM range current monitoring relays protect single-phase mains (DC or AC) from over- and undercurrent from 3 mA to 15 A. Two different terminal versions are available. You can choose between the proven screw connection technology (double-chamber cage connecting terminals) and the completely tool-free Easy Connect Technology (push-in terminals).

Ordering details

Rated control supply voltage	Function	Tripping delay T_V	Measuring range	Type	Order code	Price 1 pce	Weight (1 pce) kg (lb)			
24-240 V AC/DC	 	without	3-30 mA 10-100 mA 0.1-1 A	CM-SRS.11S	1SVR730840R0200		0.145 (0.320)			
110-130 V AC					1SVR730841R0200		0.161 (0.355)			
220-240 V AC					1SVR730841R1200		0.161 (0.355)			
24-240 V AC/DC				 	without	3-30 mA 10-100 mA 0.1-1 A	CM-SRS.11P	1SVR740840R0200		0.137 (0.302)
110-130 V AC								1SVR740841R0200		0.153 (0.337)
220-240 V AC								1SVR740841R1200		0.153 (0.337)
24-240 V AC/DC	 	without	0.3-1.5 A 1-5 A 3-15 A	CM-SRS.12S	1SVR730840R0300		0.137 (0.302)			
110-130 V AC					1SVR730841R0300		0.168 (0.370)			
220-240 V AC					1SVR730841R1300		0.168 (0.370)			
24-240 V AC/DC	 	adjustable 0 or 0.1-30 s	3-30 mA 10-100 mA 0.1-1 A	CM-SRS.21S	1SVR730840R0400		0.152 (0.335)			
110-130 V AC					1SVR730841R0400		0.179 (0.395)			
220-240 V AC					1SVR730841R1400		0.179 (0.395)			
24-240 V AC/DC				 	adjustable 0 or 0.1-30 s	3-30 mA 10-100 mA 0.1-1 A	CM-SRS.21P	1SVR740840R0400		0.168 (0.370)
110-130 V AC								1SVR740841R0400		0.168 (0.370)
220-240 V AC								1SVR740841R1400		0.168 (0.370)
24-240 V AC/DC	 	adjustable 0 or 0.1-30 s	0.3-1.5 A 1-5 A 3-15 A	CM-SRS.22S	1SVR730840R0500		0.144 (0.399)			
110-130 V AC					1SVR730841R0500		0.181 (0.399)			
220-240 V AC					1SVR730841R1500		0.181 (0.399)			
24-240 V AC/DC	  	adjustable 0 or 0.1-30 s	3-30 mA 10-100 mA 0.1-1 A	CM-SRS.M1S	1SVR730840R0600		0.153 (0.337)			
24-240 V AC/DC				 	adjustable 0 or 0.1-30 s	0.3-1.5 A 1-5 A 3-15 A	CM-SRS.M1P	1SVR740840R0600		0.142 (0.313)
24-240 V AC/DC	 	adjustable 0 or 0.1-30 s	0.3-1.5 A 1-5 A 3-15 A				CM-SRS.M2S	1SVR730840R0700		0.155 (0.342)
24-240 V AC/DC				  	adjustable 0 or 0.1-30 s	3-30 mA 10-100 mA 0.1-1 A	CM-SFS.21S	1SVR730760R0400		0.150 (0.331)
24-240 V AC/DC	 	adjustable 0 or 0.1-30 s	0.3-1.5 A 1-5 A 3-15 A				CM-SFS.21P	1SVR740760R0400		0.139 (0.306)
24-240 V AC/DC				  	adjustable 0 or 0.1-30 s	0.3-1.5 A 1-5 A 3-15 A	CM-SFS.22S	1SVR730760R0500		0.158 (0.348)









CM-SRS.22S

2CDC 251 054 V0011



CM-SFS.22P

2CDC 251 058 V0011

-  Overcurrent monitoring
-  Undercurrent monitoring
-  Without latching
-  With latching
-  1x2 c/o (SPDT) contacts
-  2x1 c/o (SPDT) contact

S: screw connection
P: push-in / easy connect

Current and voltage monitoring relays, single-phase







Ordering details - Voltage monitoring relays

Description

The CM range voltage monitoring relays provide reliable monitoring of voltages as well as detection of phase loss in single-phase mains.

All devices are available with two different terminal versions. You can choose between the proven screw connection technology (double-chamber cage connecting terminals) and the completely tool-free Easy Connect Technology (push-in terminals).

Ordering details

Rated control supply voltage	Function	Tripping delay T_V	Measuring range	Type	Order code	Price 1 pce	Weight (1 pce) kg (lb)			
24-240 V AC/DC		without	3-30 V 6-60 V 30-300 V 60-600 V	CM-ESS.1S	1SVR730830R0300		0.135 (0.298)			
110-130 V AC					1SVR730831R0300		0.164 (0.362)			
220-240 V AC							CM-ESS.1P	1SVR740830R0300		0.126 (0.278)
24-240 V AC/DC								1SVR740831R0300		0.155 (0.342)
110-130 V AC							1SVR740830R0400		0.153 (0.337)	
220-240 V AC							1SVR740831R0400		0.181 (0.399)	
24-240 V AC/DC		adjustable 0 or 0.1-30 s	3-30 V 6-60 V 30-300 V 60-600 V	CM-ESS.2S	1SVR730830R0400		0.153 (0.337)			
110-130 V AC					1SVR730831R0400		0.181 (0.399)			
220-240 V AC							CM-ESS.2P	1SVR740830R0400		0.142 (0.313)
24-240 V AC/DC								1SVR740831R0400		0.170 (0.375)
110-130 V AC							1SVR740830R0500		0.154 (0.340)	
220-240 V AC							1SVR740831R0500		0.143 (0.320)	
24-240 V AC/DC		adjustable 0 or 0.1-30 s	3-30 V 6-60 V 30-300 V 60-600 V	CM-EFS.2S	1SVR730750R0400		0.157 (0.346)			
24-240 V AC/DC					CM-EFS.2P	1SVR740750R0400		0.146 (0.322)		
										



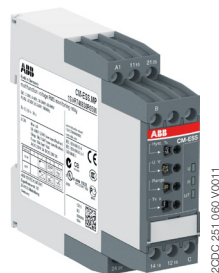

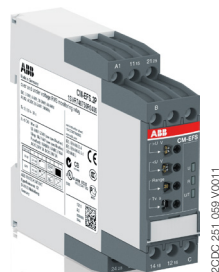

S: screw connection
P: push-in / easy connect



CM-ESS.MP



CM-EFS.2

-  Overcurrent monitoring
-  Undercurrent monitoring
-  Without latching
-  With latching
-  1x2 c/o (SPDT) contacts
-  2x1 c/o (SPDT) contact

Current and voltage monitoring relays, single-phase

Function diagrams

Function diagrams - CM-SRS.1

Overcurrent monitoring

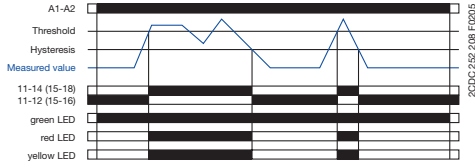

Undercurrent monitoring

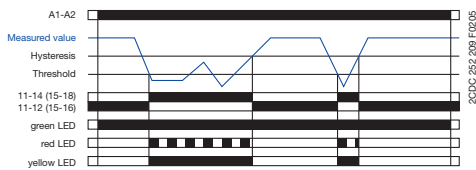

Function diagrams - CM-SRS.2

Overcurrent monitoring

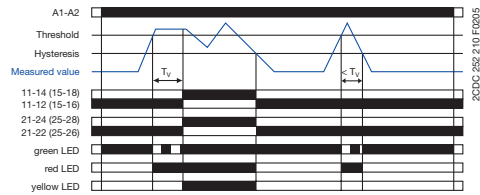

Undercurrent monitoring

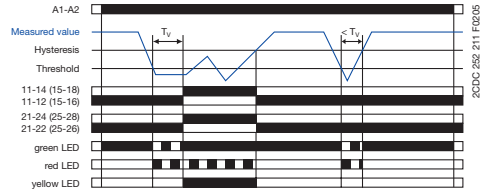

If the measured value exceeds resp. drops below the adjusted threshold value, the output relay(s) energize(s): on the CM-SRS.1 immediately, on the CM-SRS.2 after the set tripping delay T_V . If the measured value exceeds resp. drops below the threshold value plus resp. minus the adjusted hysteresis, the output relay(s) de-energize(s). The hysteresis is adjustable within a range of 3-30 % of the threshold value.

Function diagrams - CM-SRS.M

Overcurrent monitoring without latching

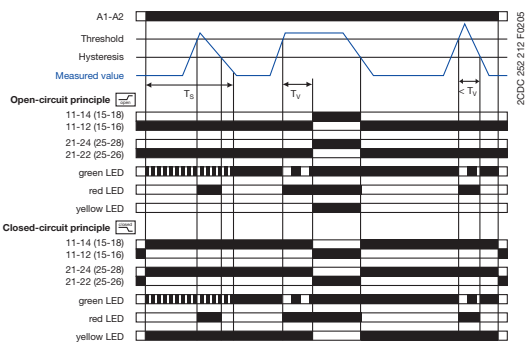

Undercurrent monitoring without latching

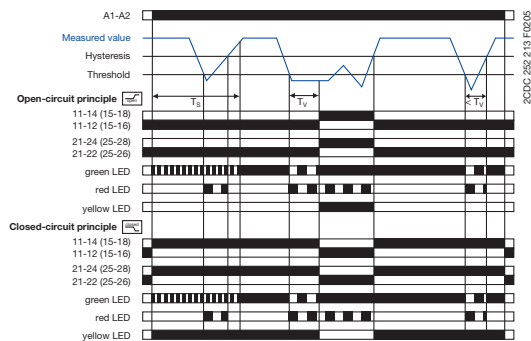

Overcurrent monitoring with latching

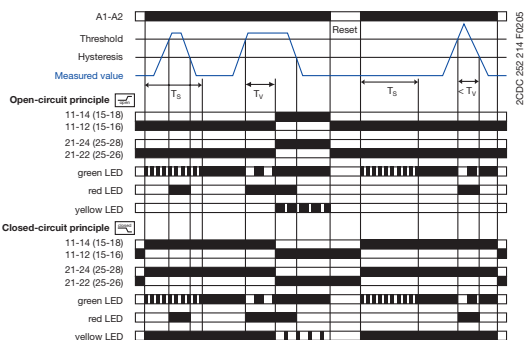

Undercurrent monitoring with latching

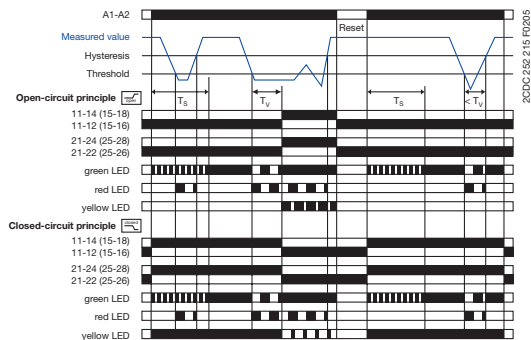

If the measured value exceeds resp. drops below the adjusted threshold value before the set start-up delay T_S is complete, the output relays do not change their actual state. If the measured value exceeds resp. drops below the adjusted threshold value when T_S is complete, the tripping delay T_V starts. If T_V is complete and the measured value is still exceeding resp. below the threshold value plus resp. minus the set hysteresis, the output relays energize / de-energize .

If the measured value exceeds resp. drops below the threshold value minus resp. plus the set hysteresis and the latching function is not activated , the output relays de-energize / energize . With activated latching function , the output relays remain energized and de-energize only, when the supply voltage is interrupted / the output relays remain de-energized and energize only, when the supply voltage is switched off and then again switched on = Reset.

The hysteresis is adjustable within a range of 3-30 % of the threshold value.

Current and voltage monitoring relays, single-phase

Function diagrams

Function diagrams - CM-SFS.2

Current window monitoring 1x2 c/o contact
ON-delayed without latching

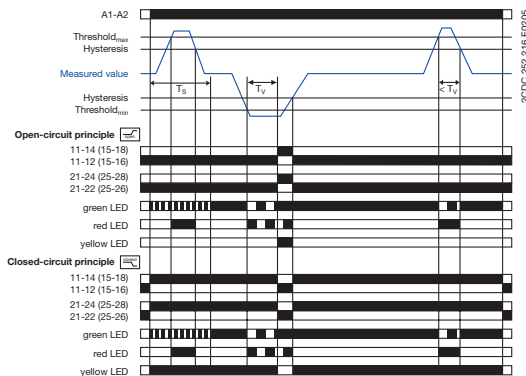

Further function diagrams see data sheet.

Current window monitoring 1x2 c/o contact
OFF-delayed without latching

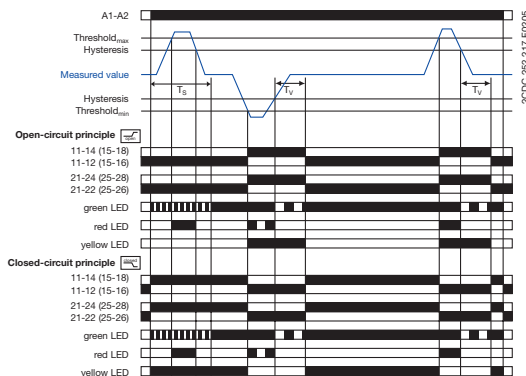

ON-delayed current window monitoring with parallel switching c/o contacts

If the measured value exceeds resp. drops below the adjusted threshold value before the set start-up delay T_s is complete, the output relays do not change their actual state.

If the measured value exceeds resp. drops below the adjusted threshold value when T_s is complete, the tripping delay T_v starts, when is configured. If T_v is complete and the measured value is still exceeding resp. below the threshold value minus resp. plus the fixed hysteresis (5%), the output relays energize /de-energize .

If the measured value exceeds resp. drops below the threshold value plus resp. minus the hysteresis and the latching function is not activated , the output relays de-energize / energize . With activated latching function the output relays remain energized and de-energize only, when the supply voltage is interrupted / the output relays remain de-energized and energize only, when the supply voltage is switched off and then again switched on = Reset.

OFF-delayed current window monitoring with parallel switching c/o contacts

If the measured value exceeds resp. drops below the adjusted threshold value when the set start-up delay T_s is complete, the output relays energize / de-energize , when is configured, and remain in this position during the set tripping delay T_v . If the measured value exceeds resp. drops below the threshold value plus resp. minus the fixed hysteresis (5%) and the latching function is not activated , the tripping delay T_v starts. After completion of T_v , the output relays de-energize / energize , provided that the latching function is not activated . With activated latching function the output relays remain energized and de-energize only, when the supply voltage is interrupted / the output relays remain de-energized and energize only, when the supply voltage is switched off and then again switched on = Reset. When is adjusted on the device, the functionality is equivalent to the one described above. There is only to consider that in this case, instead of both output relays, only one output relay each will be switched.

$$">I" = 11_{15}-12_{16}/14_{18}; "<I" = 21_{25}-22_{26}/24_{28}$$

Function diagrams - CM-ESS.1

Overvoltage monitoring

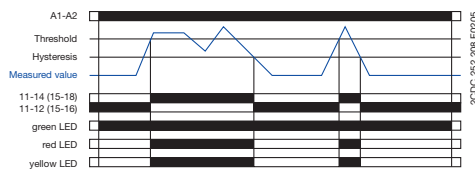

Undervoltage monitoring

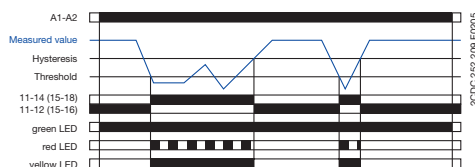

Function diagrams - CM-ESS.2

Overvoltage monitoring

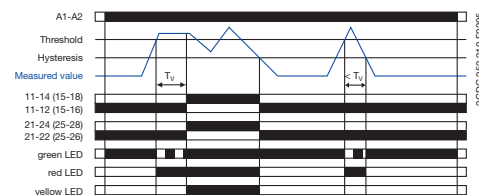

Undervoltage monitoring

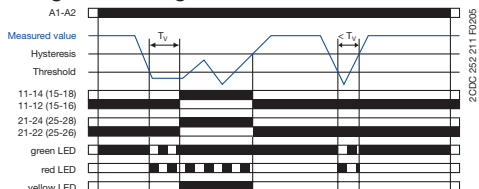

Depending on the configuration, the voltage monitoring relays **CM-ESS.1** and **CM-ESS.2** can be used for over- or undervoltage monitoring in single-phase AC and/or DC systems. The voltage to be monitored (measured value) is applied to terminals B-C. The devices work according to the open-circuit principle. If the measured value exceeds resp. drops below the adjusted threshold value, the output relay(s) energize(s): on the CM-ESS.1 immediately, on the CM-ESS.2 after the set tripping delay T_v . If the measured value exceeds resp. drops below the threshold value plus resp. minus the adjusted hysteresis, the output relay(s) de-energize(s). The hysteresis is adjustable within a range of 3-30 % of the threshold value.

Current and voltage monitoring relays, single-phase

Function diagrams

Function diagrams - CM-ESS.M

Overvoltage monitoring without latching

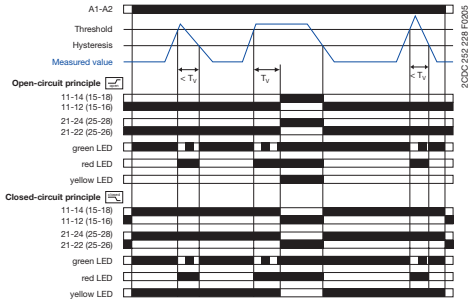

Overvoltage monitoring with latching

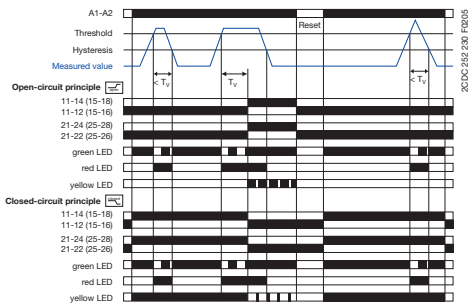

Undervoltage monitoring without latching

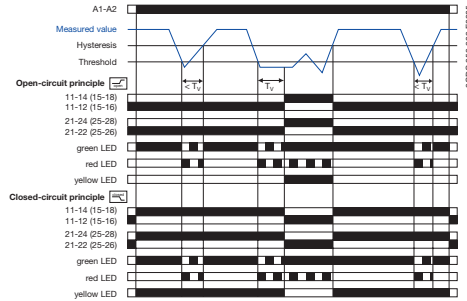

Undervoltage monitoring with latching

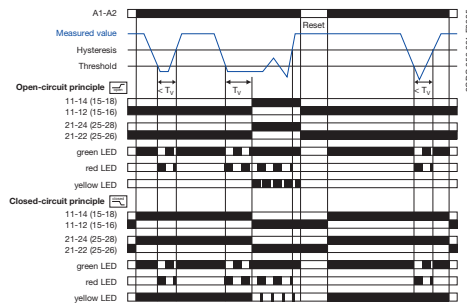

If the measured value exceeds resp. drops below the adjusted threshold value, the tripping delay T_V starts. If T_V is complete and the measured value is still exceeding resp. below the threshold value plus resp. minus the set hysteresis, the output relays energize / de-energize .

If the measured value exceeds resp. drops below the threshold value plus resp. minus the set hysteresis and the latching function is not activated , the output relays de-energize / energize . With activated latching function the output relays remain energized and de-energize only, when the supply voltage is interrupted / the output relays remain de-energized and energize only, when the supply voltage is switched off and then again switched on = Reset. The hysteresis is adjustable within a range of 3-30 % of the threshold value.

Further function diagrams see data sheet.

Voltage window monitoring 1x2 c/o contact

ON-delayed without latching

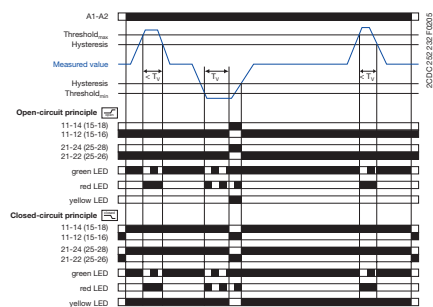

ON-delayed voltage window monitoring with parallel switching c/o contacts

If the measured value exceeds resp. drops below the adjusted threshold value, the tripping delay T_V starts, when is configured. If T_V is complete and the measured value is still exceeding resp. below the threshold value minus resp. plus the fixed hysteresis (5%), the output relays energize / de-energize .

If the measured value exceeds resp. drops below the threshold value plus resp. minus the hysteresis and the latching function is not activated , the output relays de-energize / energize . With activated latching function the output relays remain energized and de-energize only, when the supply voltage is interrupted / the output relays remain de-energized and energize only, when the supply voltage is switched off and then again switched on = Reset.

OFF-delayed voltage window monitoring with parallel switching c/o contacts

If the measured value exceeds resp. drops below the adjusted threshold value, the output relays energize / de-energize , when is configured, and remain in this position during the set tripping delay T_V .

If the measured value exceeds resp. drops below the threshold value plus resp. minus the fixed hysteresis (5%) and the latching function is not activated , the tripping delay T_V starts.

After completion of T_V , the output relays de-energize / energize , provided that the latching function is not activated . With activated latching function the output relays remain energized and de-energize only, when the supply voltage is interrupted / the output relays remain de-energized and energize only, when the supply voltage is switched off and then again switched on = Reset.

When is adjusted on the device, the functionality is equivalent to the one described above. There is only to consider that in this case, instead of both output relays, only one output relay each will be switched.

$$">U" = 11_{15}-12_{16}/14_{18}; "<U" = 21_{25}-22_{26}/24_{28}$$

Voltage window monitoring 1x2 c/o contact

OFF-delayed without latching

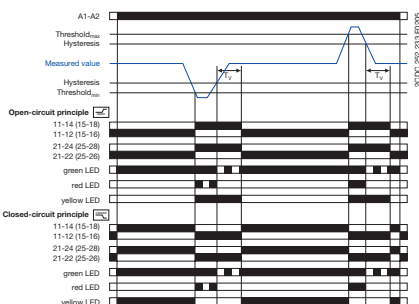

Current and voltage monitoring relays, single-phase

Connection diagrams, DIP switches

Connection diagram CM-SRS.1, CM-SRS.2

A1	11 ₁₅	C
B1	B2	B3

2CDC 252 204 F0005

A1	11 ₁₅	21 ₂₅
B1	B2	B3

2CDC 252 205 F0005

A1-A2 Control supply voltage
 B1-C Measuring range 1: 3-30 mA or 0.3-1.5 A
 B2-C Measuring range 2: 10-100 mA or 1-5 A
 B3-C Measuring range 3: 0.1-1 A or 3-15 A
 11₁₅-12₁₆/14₁₈ Output contacts - open-circuit principle

A1-A2 Control supply voltage
 B1-C Measuring range 1: 3-30 mA or 0.3-1.5 A
 B2-C Measuring range 2: 10-100 mA or 1-5 A
 B3-C Measuring range 3: 0.1-1 A or 3-15 A
 11₁₅-12₁₆/14₁₈ Output contacts - open-circuit principle
 21₂₅-22₂₆/24₂₈ open-circuit principle

DIP switch functions CM-SRS.1, CM-SRS.2

Position	2	1
ON ↑		
OFF		

2CDC 252 272 F0005

1 ON Undercurrent monitoring
 OFF Overcurrent monitoring
 OFF = Default

Connection diagram CM-SRS.M

A1	11 ₁₅	21 ₂₅
B1	B2	B3

2CDC 252 205 F0005

A1-A2 Control supply voltage
 B1-C Measuring range 1: 3-30 mA bzw. 0.3-1.5 A
 B2-C Measuring range 2: 10-100 mA bzw. 1-5 A
 B3-C Measuring range 3: 0.1-1 A bzw. 3-15 A
 11₁₅-12₁₆/14₁₈ Output contacts - open- or closed circuit principle

DIP switch functions CM-SRS.M

Position	4	3	2	1
ON ↑				
OFF				

2CDC 252 273 F0005

1 ON Undercurrent monitoring
 OFF Overcurrent monitoring
 2 ON Closed-circuit principle
 OFF Open-circuit principle
 3 ON Latching function activated
 OFF Latching function not activated
 OFF = Default

Connection diagram CM-SFS.2

A1	11 ₁₅	21 ₂₅
B1	B2	B3

2CDC 252 205 F0005

A1-A2 Control supply voltage
 B1-C Measuring range 1: 3-30 mA or 0.3-1.5 A
 B2-C Measuring range 2: 10-100 mA or 1-5 A
 B3-C Measuring range 3: 0.1-1 A or 3-15 A
 11₁₅-12₁₆/14₁₈ Output contacts - open- or closed circuit principle

DIP switch function CM-SFS.2

Position	4	3	2	1
ON ↑				
OFF				

2CDC 252 274 F0005

1 ON OFF-delay
 OFF ON-delay
 2 ON Closed-circuit principle
 OFF Open-circuit principle
 3 ON Latching function activated
 OFF Latching function not activated
 4 ON 2x1 c/o contact
 OFF 1x2 c/o contacts
 OFF = Default

Connection diagram CM-ESS.M

A1	11 ₁₅	21 ₂₅
B		

2CDC 252 207 F0005

A1-A2 Control supply voltage
 B-C Measuring ranges: 3-30 V; 6-60 V; 30-300 V; 60-600 V
 11₁₅-12₁₆/14₁₈ Output contacts - Open- or closed circuit principle

DIP switch functions CM-ESS.M

Position	4	3	2	1
ON ↑				
OFF				

2CDC 252 276 F0005

1 ON Undervoltage monitoring
 OFF Overvoltage monitoring
 2 ON Closed-circuit principle
 OFF Open-circuit principle
 3 ON Latching function activated
 OFF Latching function not activated
 OFF = Default

Current and voltage monitoring relays, single-phase

Connection diagrams, DIP switches

2

Connection diagram CM-ESS.1, CM-ESS.2

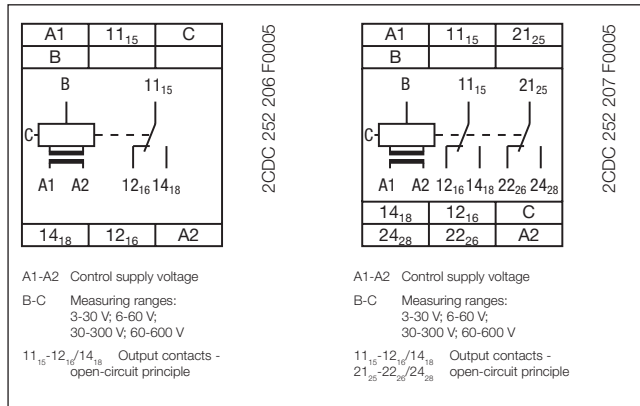

DIP switch functions CM-ESS.1, CM-ESS.2

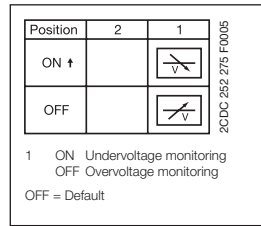

Connection diagram CM-EFS.2

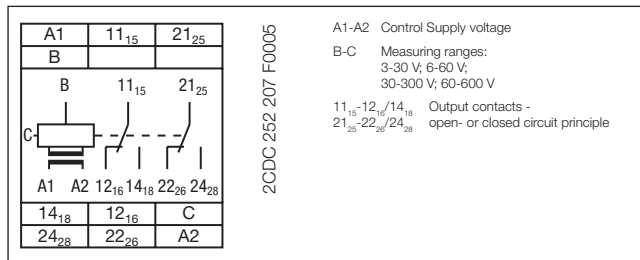

DIP switch functions CM-EFS.2

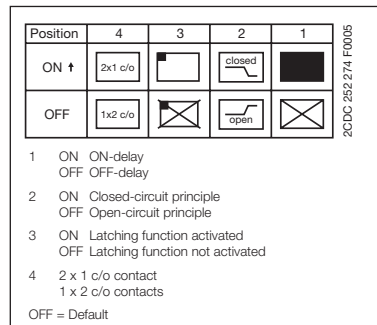

Current monitoring relays, single-phase

Technical data - Current monitoring relays

Type		CM-SRS.1	CM-SRS.2	CM-SRS.M	CM-SFS.2	
Input circuit - Supply circuit		A1-A2				
Rated control supply voltage U_s	A1-A2	110-130 V AC				
	A1-A2	220-240 V AC				
	A1-A2	24-240 V AC/DC				
Rated control supply voltage U_s tolerance		-15...+10 %				
Rated frequency	AC versions	50/60 Hz				
	AC/DC versions	50/60 Hz or DC				
Current / power consumption		see data sheets				
Power failure buffering time		20 ms				
Transient overvoltage protection		Varistors				
Input circuit - Measuring circuit		B1/B2/B3-C				
Monitoring function		over- or undercurrent monitoring configurable			over- and under- current monitoring	
Measuring method		True RMS measuring principle				
Measuring inputs		CM-SxS.x1			CM-SxS.x2	
Terminal connection		B1-C	B2-C	B3-C	B1-C	B2-C
Measuring ranges AC/DC		3-30 mA	10-100 mA	0.1-1 A	0.3-1.5 A	1-5 A
Input resistance		3.3 Ω	1 Ω	0.1 Ω	0.05 Ω	0.01 Ω
Pulse overload capacity $t < 1$ s		500 mA	1 A	10 A	15 A	50 A
Continuous capacity		50 mA	150 mA	1.5 A	2 A	7 A
Threshold value(s)		adjustable within the indicated measuring range				
Setting accuracy of threshold value		10 %				
Repeat accuracy (constant parameters)		0.07 % of full scale				
Hysteresis related to the threshold value		3-30 % adjustable			5 % fixed	
Measuring signal frequency range		DC / 15 Hz - 2 kHz				
Rated measuring signal frequency range		DC / 50-60 Hz				
Maximum response time		AC: 80 ms / DC: 120 ms				
Accuracy within the control supply voltage tolerance		$\Delta U \leq 0.5$ %				
Accuracy within the temperature range		$\Delta U \leq 0.06$ % / °C				
Timing circuit						
Start-up delay T_s		none	0 or 0.1-30 s adjustable			
Tripping delay T_v		none	0 or 0.1-30 s adjustable			
Repeat accuracy (constant parameters)		± 0.07 % of full scale				
Accuracy within the control supply voltage tolerance		-	$\Delta t \leq 0.5$ %			
Accuracy within the temperature range		-	$\Delta t \leq 0.06$ % / °C			
Indication of operational states						
Control supply voltage	U/T: green LED	 : control supply voltage applied, : start-up delay T_s active, : tripping delay T_v active				
Measured value	I: red LED	 : overcurrent, : undercurrent				
Relay status	R: yellow LED	 : relay energized, no latching function : relay energized, active latching function : relay de-energized, active latching function				
Output circuits		11(15)-12(16)/14(18), 21(25)-22(26)/24(28) - Relays				
Kind of output		1 c/o contact	2 c/o contacts		1x2 c/o contacts or 2x1 c/o contact configurable	
Operating principle		open-circuit principle ¹⁾		open- or closed-circuit principle configurable ¹⁾		
Contact material		AgNi				
Rated operational voltage U_o	IEC/EN 60947-1	250 V				
Minimum switching voltage / minimum switching current		24 V / 10 mA				
Maximum switching voltage / maximum switching current		250 V AC / 4 A AC				
Rated operational current I_o (IEC/EN 60947-5-1)	AC12 (resistive) at 230 V	4 A				
	AC15 (inductive) at 230 V	3 A				
	DC12 (resistive) at 24 V	4 A				
	DC13 (inductive) at 24 V	2 A				
AC rating (UL 508)	Utilization category (Control Circuit Rating Code)	B 300				
	max. rated operational voltage	300 V AC				
	max. continuous thermal current at B 300	5 A				
	max. making/breaking apparent power (Make/Break) at B 300	3600/360 VA				
Mechanical lifetime		30x10 ⁶ switching cycles				
Electrical lifetime (AC12, 230 V, 4 A)		0.1x10 ⁶ switching cycles				
Max. fuse rating to achieve short-circuit protection	n/c contact	6 A fast-acting	10 A fast-acting		6 A fast-acting	
	n/o contact	10 A fast-acting				

¹⁾ Open-circuit principle: output relay energizes if the measured value exceeds / falls below the adjusted threshold value
Closed-circuit principle: output relay de-energizes if measured value exceeds / falls below the adjusted threshold value

²⁾ In case of measured currents > 10 A, lateral spacing has to be min. 10 mm

Current monitoring relays, single-phase

Technical data - Current monitoring relays







2

Type		CM-SRS.1	CM-SRS.2	CM-SRS.M	CM-SFS.2
General data					
MTBF		on request			
Duty time		100%			
Dimensions (W x H x D)	product dimensions	22.5 x 85.6 x 103.7 mm (0.89 x 3.37 x 4.08 in)			
	packaging dimensions	97 x 109 x 30 mm (3.82 x 4.29 x 1.18 in)			
Weight	net weight	depending on device, see ordering details			
	gross weight	depending on device, see ordering details			
Mounting		DIN rail (IEC/EN 60715), snap-on mounting without any tool			
Mounting position		any			
Minimum distance to other units		10mm (0.39in) at measured current > 10 A ²⁾			
Material of housing		UL 94 V-0			
Degree of protection	housing / terminals	IP50 / IP20			
Electrical connection					
Wire size		Screw connection technology		Easy Connect Technology (Push-in)	
	fine-strand with(out) wire end ferrule	1 x 0.5-2.5 mm ² (1 x 20-14 AWG) 2 x 0.5-1.5 mm ² (2 x 20-16 AWG)		2 x 0.5-1.5 mm ² (2 x 20-16 AWG)	
		rigid	1 x 0.5-4 mm ² (1 x 20-12 AWG) 2 x 0.5-2.5 mm ² (2 x 20-14 AWG)		2 x 0.5-1.5 mm ² (2 x 20-16 AWG)
Stripping length		8 mm (0.32 in)			
Tightening torque		0.6-0.8 Nm (5.31-7.08 lb.in)		-	
Environmental data					
Ambient temperature range	operation / storage	-20...+60 °C / -40...+85 °C			
Damp heat (IEC 60068-2-30)		55 °C, 6 cycles			
Vibration (sinusoidal) (IEC/EN 60255-21-1)		Class 2			
Shock (IEC/EN 60255-21-2)		Class 2			
Isolation data					
Rated insulation voltage (VDE 0110, IEC 60947-1, IEC/EN 60255-5)	supply / measuring circuit / output	600 V			
	supply / output 1/2	250 V			
Rated impulse withstand voltage U _{imp} (IEC/EN 60947-1, IEC/EN 60255-5)	supply / measuring circuit / output	6 kV 1.2/50 µs			
	supply / output 1/2	4 kV 1.2/50 µs			
Pollution degree (VDE 0110, IEC 664, IEC/EN 60255-5)		3			
Overvoltage category (VDE 0110, IEC 664, IEC/EN 60255-5)		III			
Standards					
Product standard		IEC/EN 60255-6			
Low Voltage Directive		2006/95/EC			
EMC Directive		2004/108/EC			
Electromagnetic compatibility					
Interference immunity to		IEC/EN 61000-6-2			
electrostatic discharge	IEC/EN 61000-4-2	Level 3			
radiated, radio-frequency, electromagnetic field	IEC/EN 61000-4-3	Level 3			
electrical fast transient / burst	IEC/EN 61000-4-4	Level 3			
surge	IEC/EN 61000-4-5	Level 3			
conducted disturbances, induced by radio-frequency fields	IEC/EN 61000-4-6	Level 3			
Interference emission		IEC/EN 61000-6-3			
high-frequency radiated	IEC/CISPR 22; EN 55022	Class B			
high-frequency conducted	IEC/CISPR 22; EN 55022	Class B			

Voltage monitoring relays, single-phase

Technical data - Voltage monitoring relays

2

Type		CM-ESS.1	CM-ESS.2	CM-ESS.M	CM-EFS.2
Input circuit - Supply circuit		A1-A2			
Rated control supply voltage U_s	A1-A2	110-130 V AC			
	A1-A2	220-240 V AC			
	A1-A2	24-240 V AC/DC			
Rated control supply voltage U_s tolerance		-15...+10 %			
Rated frequency	AC versions	50/60 Hz			
	AC/DC versions	50/60 Hz or DC			
Current / power consumption		see data sheet			
Power failure buffering time		20 ms			
Transient overvoltage protection		Varistors			
Input circuit - Measuring circuit		B-C			
Monitoring function		over- or undervoltage monitoring configurable		over- and undervoltage monitoring configurable	
Measuring method		True RMS measuring principle			
Measuring inputs		CM-ExS			
	Terminal connection	B-C	B-C	B-C	B-C
	Measuring range AC/DC	3-30 V	6-60 V	30-300 V	60-600 V
	Input resistance	600 k Ω	600 k Ω	600 k Ω	600 k Ω
	Pulse overload capacity $t < 1$ s	800 V	800 V	800 V	800 V
	Continuous capacity	660 V	660 V	660 V	660 V
Threshold value(s)		adjustable within the indicated measuring range			
Setting accuracy of threshold value		10 %			
Repeat accuracy (constant parameters)		± 0.07 % of full scale			
Hysteresis related to the threshold value		3-30 % adjustable			5 % fixed
Measuring signal frequency range		DC / 15 Hz - 2 kHz			
Rated measuring signal frequency range		DC / 50-60 Hz			
Maximum response time		AC: 80 ms / DC: 120 ms			
Accuracy within the control supply voltage tolerance		$\Delta U \leq 0.5$ %			
Accuracy within the temperature range		$\Delta U \leq 0.06$ % / $^{\circ}\text{C}$			
Transient overvoltage protection		Varistors			
Timing circuit					
Delay time T_v		none	0 or 0.1-30 s adjustable		
Repeat accuracy (constant parameters)		± 0.07 % of full scale			
Accuracy within the control supply voltage tolerance		-	$\Delta t \leq 0.5$ %		
Accuracy within the temperature range		-	$\Delta t \leq 0.06$ % / $^{\circ}\text{C}$		
Indication of operational states					
Control supply voltage	U/T: green LED	 : control supply voltage applied  : tripping delay T_v active			
Measured value	U: red LED	 : overvoltage,  : undervoltage			
Relay status	R: yellow LED	 : relay energized, no latching function  : relay energized, active latching function  : relay de-energized, active latching function			
Output circuits					
Kind of output		1 c/o contact	2 c/o contacts	1x2 c/o contacts or 2x1 c/o contact configurable	
Operating principle		open-circuit principle ¹⁾		open- or closed-circuit principle configurable ¹⁾	
Contact material		AgNi			
Rated operational voltage U_e	IEC/EN 60947-1	250 V			
Minimum switching voltage / minimum switching current		24 V / 10 mA			
Maximum switching voltage / maximum switching current		250 V AC / 4 A AC			
Rated operational current I_e (IEC/EN 60947-5-1)	AC12 (resistive) at 230 V	4 A			
	AC15 (inductive) at 230 V	3 A			
	DC12 (resistive) at 24 V	4 A			
	DC13 (inductive) at 24 V	2 A			

¹⁾ Open-circuit principle: output relay energizes if the measured value exceeds  / falls below  the adjusted threshold value
 Closed-circuit principle: output relay de-energizes if measured value exceeds  / falls below  the adjusted threshold value

Voltage monitoring relays, single-phase

Technical data - Voltage monitoring relays

2

Type		CM-ESS.1	CM-ESS.2	CM-ESS.M	CM-EFS.2
AC rating (UL 508)	Utilization category (Control Circuit Rating Code)	B 300			
	max. rated operational voltage	300 V AC			
	max. continuous thermal current at B 300	5 A			
	max. making/breaking apparent power (Make/Break) at B 300	3600/360 VA			
Mechanical lifetime		30x10 ⁶ switching cycles			
Electrical lifetime (AC12, 230 V, 4 A)		0.1x10 ⁶ switching cycles			
Max. fuse rating to achieve short-circuit protection	n/c contact	6 A fast-acting	10 A fast-acting	6 A fast-acting	
	n/o contact	10 A fast-acting			
General data					
MTBF		on request			
Duty time		100%			
Dimensions (W x H x D)	product dimensions	22.5 x 85.6 x 103.7 mm (0.89 x 3.37 x 4.08 in)			
	packaging dimensions	97 x 109 x 30 mm (3.82 x 4.29 x 1.18 in)			
Weight	net weight	depending on device, see ordering details			
	gross weight	depending on device, see ordering details			
Mounting		DIN rail (IEC/EN 60715), snap-on mounting without any tool			
Mounting position		any			
Minimum distance to other units	vertical / horizontal	not necessary / not necessary			
Material of housing		UL 94 V-0			
Degree of protection	housing / terminals	IP50 / IP20			
Electrical connection					
Wire size		Screw connection technology		Easy Connect Technology (Push-in)	
	fine-strand with(out) wire end ferrule	1 x 0.5-2.5 mm ² (1 x 20-14 AWG) 2 x 0.5-1.5 mm ² (2 x 20-16 AWG)		2 x 0.5-1.5 mm ² (2 x 20-16 AWG)	
	rigid	1 x 0.5-4 mm ² (1 x 20-12 AWG) 2 x 0.5-2.5 mm ² (2 x 20-14 AWG)		2 x 0.5-1.5 mm ² (2 x 20-16 AWG)	
Stripping length		8 mm (0.32 in)			
Tightening torque		0.6-0.8 Nm (5.31-7.08 lb.in)		-	
Isolation data					
Rated insulation voltage (VDE 0110, IEC 60947-1, IEC/EN 60255-5)	supply / measuring circuit / output	600 V			
	supply / output 1/2	250 V			
Rated impulse withstand voltage U _{imp} (IEC/EN 60947-1, IEC/EN 60255-5)	supply / measuring circuit / output	6 kV 1.2/50 μs			
	supply / output 1/2	4 kV 1.2/50 μs			
Pollution degree (VDE 0110, IEC 664, IEC/EN 60255-5)		3			
Overvoltage category (VDE 0110, IEC 664, IEC/EN 60255-5)		III			
Standards					
Product standard		IEC/EN 60255-6			
Low Voltage Directive		2006/95/EC			
EMC Directive		2004/108/EC			
Electromagnetic compatibility					
Interference immunity to electrostatic discharge	IEC/EN 61000-4-2	IEC/EN 61000-6-2 Level 3			
radiated, radio-frequency, electromagnetic field	IEC/EN 61000-4-3	Level 3			
electrical fast transient / burst	IEC/EN 61000-4-4	Level 3			
surge	IEC/EN 61000-4-5	Level 3			
conducted disturbances, induced by radio-frequency fields	IEC/EN 61000-4-6	Level 3			
Interference emission		IEC/EN 61000-6-3			
high-frequency radiated	IEC/CISPR 22; EN 55022	Class B			
high-frequency conducted	IEC/CISPR 22; EN 55022	Class B			

Three-phase monitoring relays

Product group picture

2



Three-phase monitoring relays

Table of contents

Three-phase monitoring relays	
Product group picture	27
Table of contents	28
Benefits and advantages, Applications	29
Operating controls	30
Selection table singlefunctional	31
Selection table multifunctional	32
Ordering details - Singlefunctional	33
Ordering details - Multifunctional	34
Function diagrams	35
Connection diagrams, DIP switches	39
DIP switches, Rotary switches	40
Technical data	41

Three-phase monitoring relays

Benefits and advantages, Applications

2

Characteristics of the CM range three-phase monitors

- Adjustable phase unbalance threshold value ¹⁾
- Adjustable ON-delay/OFF-delay time ¹⁾
- Dual frequency measuring 50/60 Hz
- Powered by the measuring circuit
- 1 n/o contact, 1 or 2 c/o contacts
- LEDs for the indication of operational states
- Multifunctional and single-functional devices
- Phase failure detection
- Phase sequence monitoring ¹⁾
- Over- and undervoltage monitoring (fixed or adjustable)¹⁾
- Wide-range operating voltage guarantees world-wide operation
- Approvals / Marks



¹⁾ depending on device type

²⁾ Applicable in rail application following the latest standards for rail applications: NF F 16-101/102 (I2/F2 classified), EN 45545 (Hazard Level 3), DIN 5510, EN 50155, IEC 60571. Further information is available in our rail segment brochure 2CD-C110084B0201.

Phase unbalance monitoring

If the supply by the three-phase system is unbalanced due to uneven distribution of the load, the motor will convert a part of the energy into reactive power. This energy gets lost unexploited; also the motor is exposed to higher thermal stress. Other thermal protection devices fail to detect continuing unbalances which can lead to damage or destruction of the motor. The CM range three-phase monitors with phase unbalance monitoring can reliably detect this critical situation.

Phase sequence

Changing the phase sequence during operation or a wrong phase sequence prior to startup causes a change of the rotational direction of the connected device. Generators, pumps or fans rotate in the wrong direction and the installation is no longer working properly. Especially for moveable equipment, such as construction machinery, phase sequence detection prior to the startup process is highly reasonable.

Phase loss

In case of phase loss, undefined states of the installation are likely to occur. E.g. the startup process of motors is disturbed. All three-phase monitors of the ABB CM range detect a phase loss as soon as the voltage of one phase drops below 60% of its nominal value.

Voltage monitoring

All electric devices can be damaged when operated continuously in a network with out-of-range voltages. For example, safe starting is not ensured in case of undervoltage. Also, the switching state of a contactor is not clearly defined when operated in a „forbidden“ voltage range. This can lead to undefined states of the installation and cause damage or destruction of valuable parts.

Extended functionality

ABB's new generation of three-phase monitoring relays feature additional functions making the application field for the devices considerably larger.

Selectable phase sequence monitoring

The phase sequence monitoring can be switched off by means of a rotary switch or a DIP switch. This enables monitoring of three-phase mains where phase sequence is not relevant for the application, for example in case of motors with forward and reverse rotation, heating applications, etc.

Automatic phase sequence correction

The automatic phase sequence correction is activated by means of a DIP switch. With activated phase sequence correction, it is ensured that for any non-fixed or portable equipment, e.g. construction machinery, the correct phase sequence is always applied to the input terminals of the load. For details regarding the wiring, please see function description / diagrams.

Structure of the type designation

CM- _ _ x.yz

x: width of enclosure

y: Control supply voltage / measuring range

1	110, 115, 120, 127 V supply systems (phase-neutral)
2	220, 230, 240 V supply systems (phase-neutral)
3	200, 208, 220, 230, 240, 257, 260 V supply systems (phase-phase)
4	440, 460 V supply systems (phase-phase)
5	480, 500 V supply systems (phase-phase)
6	575, 600 V supply systems (phase-phase)
7	660, 690 V supply systems (phase-phase)
8	200, 400 V supply systems (phase-phase)

z: Rated frequency / output circuit

1	50/60 Hz – 1x2 c/o
2	50/60 Hz – 1x2 or 2x1 c/o
3	50/60/400 Hz – 1x2 oder 2x1 c/o

Three-phase monitoring relays

Operating controls

S-Range Housing

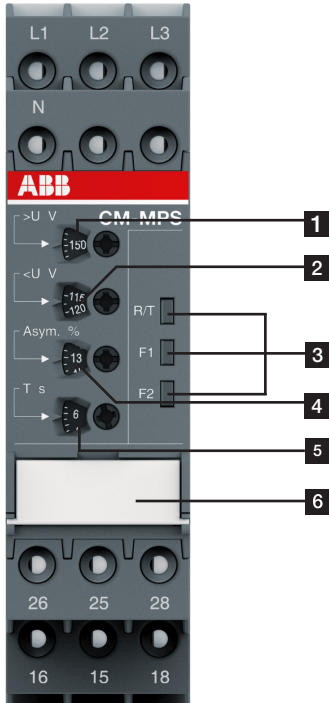

- 1** Adjustment of the hysteresis $>U$ for overvoltage
- 2** Adjustment of the threshold value $<U$ for undervoltage
- 3** Indication of operational states
R/T: red LED – Relay status / timing
F1: yellow LED – Fault message
F2: yellow LED – Fault message
- 4** Adjustment of the threshold value $Asym.$ for phase unbalance
- 5** Adjustment of the tripping delay T_v
- 6** DIP switches (see DIP switch functions on page 2/40)
 - ON-delay
 - OFF-delay
 - Phase sequence monitoring deactivated
 - Phase sequence monitoring activated
 - Phase sequence correction activated
 - Phase sequence correction deactivated
 - 2x1 c/o (SPDT) contact
 - 1x2 c/o (SPDT) contacts

2

N-Range Housing

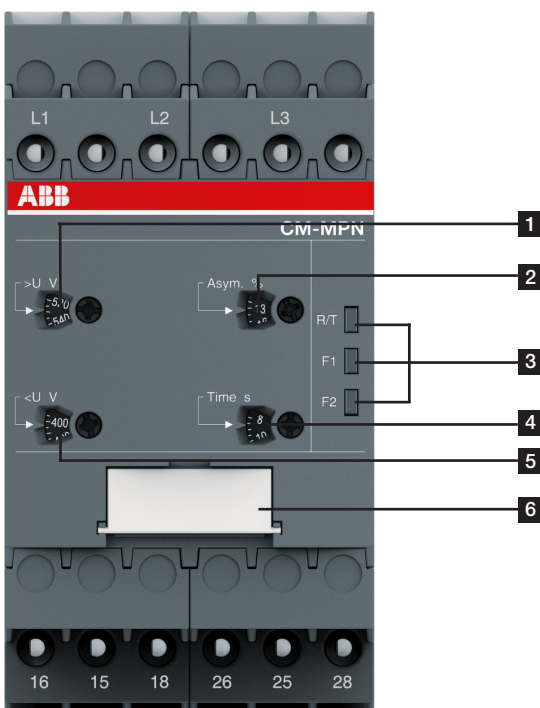

- 1** Adjustment of the hysteresis $>U$ for overvoltage
- 2** Adjustment of the threshold value $Asym.$ for phase unbalance
- 3** Indication of operational states
R/T: red LED – Relay status / timing
F1: yellow LED – Fault message
F2: yellow LED – Fault message
- 4** Adjustment of the tripping delay T_v
- 5** Adjustment of the hysteresis $<U$ for undervoltage
- 6** DIP switches (see DIP switch functions on page 2/40)
 - ON-delay
 - OFF-delay
 - Phase sequence monitoring deactivated
 - Phase sequence monitoring activated
 - Phase sequence correction activated
 - Phase sequence correction deactivated
 - 2x1 c/o (SPDT) contact
 - 1x2 c/o (SPDT) contacts

Three-phase monitoring relays

Selection table singlefunctional



Rated control supply voltage U_c	Type	Order number	1SVR 550 881 R9400	1SVR 550 882 R9500	1SVR 550 870 R9400	1SVR 550 871 R9500	1SVR 550 824 R9100	1SVR 730 824 R9300	1SVR 740 824 R9300	1SVR 730 784 R2300	1SVR 740 784 R2300	1SVR 730 784 R3300	1SVR 740 784 R3300	1SVR 730 794 R1300	1SVR 730 794 R3300	1SVR 740 794 R2300	1SVR 730 774 R1300	1SVR 740 774 R1300	1SVR 730 774 R3300	1SVR 740 774 R3300
Phase to Phase	CM-PBE																			
160-300 V AC	CM-PBE																			
200-400 V AC	CM-PBE																			
200-500 V AC	CM-PBE																			
208-440 V AC	CM-PBE																			
300-500 V AC	CM-PBE																			
320-460 V AC	CM-PBE																			
350-580 V AC	CM-PBE																			
380 V AC	CM-PBE																			
380-440 V AC	CM-PBE																			
400 V AC	CM-PBE																			
Phase to Neutral	CM-PBE																			
185-265 V AC	CM-PBE																			
220-240 V AC	CM-PBE																			
Rated frequency	CM-PBE																			
50/60 Hz	CM-PBE																			
Suitable for monitoring	CM-PBE																			
Single-phase mains	CM-PBE																			
Three-phase mains	CM-PBE																			
Monitoring function	CM-PBE																			
Phase failure	CM-PBE																			
Phase sequence	CM-PBE																			
Automatic phase sequence correction	CM-PBE																			
Overvoltage	CM-PBE																			
Undervoltage	CM-PBE																			
Unbalance	CM-PBE																			
Neutral ¹⁾	CM-PBE																			
Thresholds	CM-PBE																			
fix	CM-PBE																			
Timing functions for tripping delay	CM-PBE																			
ON delay	CM-PBE																			
On and OFF delay	CM-PBE																			
Connection type	CM-PBE																			
Push-in terminals	CM-PBE																			
Double-chamber cage connection terminals	CM-PBE																			

¹⁾ The external conductor voltage towards the neutral conductor is measured.

adj: adjustable
sel: selectable

Three-phase monitoring relays

Selection table multifunctional



	Order number																	
	Type																	
Rated control supply voltage U_c	1SVR 730 885 R1300	1SVR 740 885 R1300	1SVR 730 885 R3300	1SVR 740 885 R3300	1SVR 730 884 R1300	1SVR 740 884 R1300	1SVR 730 884 R3300	1SVR 740 884 R3300	1SVR 730 885 R4300	1SVR 740 885 R4300	1SVR 730 884 R4300	1SVR 740 884 R4300	1SVR 750 487 R6300	1SVR 760 487 R6300	1SVR 750 488 R6300	1SVR 760 488 R6300	1SVR 750 489 R6300	1SVR 760 489 R6300
CM-MPS.11S	CM-MPS.11P	CM-MPS.21S	CM-MPS.21P	CM-MPS.31S	CM-MPS.31P	CM-MPS.41S	CM-MPS.41P	CM-MPS.23S	CM-MPS.23P	CM-MPS.43S	CM-MPS.43P	CM-MPN.52S	CM-MPN.52P	CM-MPN.62S	CM-MPN.62P	CM-MPN.72S	CM-MPN.72P	
Phase to Phase																		
160-300 V AC					■	■												
300-500 V AC							■	■			■	■						
350-580 V AC													■	■				
450-720 V AC															■	■		
530-820 V AC																	■	■
Phase to Neutral																		
90-170 V AC	■	■																
180-280 V AC			■	■					■	■								
Rated frequency																		
50/60 Hz	■	■	■	■	■	■	■	■	■	■	■	■	■	■	■	■	■	■
50/60/400 Hz									■	■	■	■						
Suitable for monitoring																		
Single-phase mains	■	■	■	■	■	■	■	■	■	■	■	■	■	■	■	■	■	■
Three-phase mains	■	■	■	■	■	■	■	■	■	■	■	■	■	■	■	■	■	■
Monitoring function																		
Phase failure	■	■	■	■	■	■	■	■	■	■	■	■	■	■	■	■	■	■
Phase sequence	sel	sel	sel	sel	sel	sel	sel	sel	adj	adj	adj	adj	adj	adj	adj	adj	adj	
Automatic phase sequence correction									adj	adj	adj	adj	adj	adj	adj	adj	adj	
Overvoltage	■	■	■	■	■	■	■	■	■	■	■	■	■	■	■	■	■	
Undervoltage	■	■	■	■	■	■	■	■	■	■	■	■	■	■	■	■	■	
Unbalance	■	■	■	■	■	■	■	■	■	■	■	■	■	■	■	■	■	
Neutral ¹⁾	■ ²⁾	■ ²⁾	■ ²⁾	■ ²⁾					■ ²⁾	■ ²⁾								
Thresholds																		
adj	adj	adj	adj	adj	adj	adj	adj	adj	adj	adj	adj	adj	adj	adj	adj	adj	adj	
Timing functions for tripping delay																		
On and OFF delay	adj	adj	adj	adj	adj	adj	adj	adj	adj	adj	adj	adj	adj	adj	adj	adj	adj	
Connection type																		
Push-in terminals		■		■		■		■		■		■		■		■		
Double-chamber cage connection terminals	■		■		■		■		■		■		■		■		■	

¹⁾ The external conductor voltage towards the neutral conductor is measured. adj: adjustable
²⁾ Interrupted neutral monitoring sel: selectable

Three-phase monitoring relays

Ordering details - Singlefunctional

2

Description

Only reliable and continuous monitoring of a three-phase network guarantees the trouble-free and economic operation of machines and installations.

Ordering details

Rated control supply voltage = measuring voltage	Monitoring function	Neutral monitoring	Type	Order code	Price 1 pce	Weight (1 pce) kg (lb)
3x380-440 V AC, 220-240 V AC	Phase failure detection (Single- and three-phase)	■	CM-PBE ¹⁾	1SVR550881R9400		0.08 (0.17)
3x380-440 V AC			CM-PBE	1SVR550882R9500		0.08 (0.17)
3x320-460 V AC, 185-265 V AC	Over- / undervoltage and phase failure detection (Single- and three-phase)	■	CM-PVE ¹⁾	1SVR550870R9400		0.08 (0.17)
3x320-460 V AC			CM-PVE	1SVR550871R9500		0.08 (0.17)
3x208-440 V AC	Phase sequence monitoring and phase failure detection (Three-phase)		CM-PFE ²⁾	1SVR550824R9100		0.08 (0.17)



CM-PBE

2CDC 251 064 V0011

Ordering details

Rated control supply voltage = measuring voltage	Monitoring function	Type	Order code	Price 1 pce	Weight (1 pce) kg (lb)
3x200-500 V AC	Phase sequence monitoring and phase failure detection (Three-phase)	CM-PFS.S	1SVR730824R9300		0.127 (0.280)
		CM-PFS.P	1SVR740824R9300		0.119 (0.262)
3x380 V AC	Over- / undervoltage with fixed threshold values ± 10 %	CM-PSS.31S	1SVR730784R2300		0.132 (0.291)
		CM-PSS.31P	1SVR740784R2300		0.123 (0.271)
		CM-PSS.41S	1SVR740784R3300		0.132 (0.291)
		CM-PSS.41P	1SVR730784R3300		0.123 (0.271)
3x160-300 V AC	Over- and undervoltage with adjustable threshold values (Three-phase)	CM-PVS.31S	1SVR730794R1300		0.141 (0.311)
		CM-PVS.31P	1SVR740794R1300		0.132 (0.291)
3x300-500 V AC	Over- and undervoltage with adjustable threshold values (Three-phase)	CM-PVS.41S	1SVR730794R3300		0.139 (0.306)
		CM-PVS.41P	1SVR740794R3300		0.131 (0.289)
3x200-400 V AC	Over- and undervoltage with adjustable threshold values (Three-phase)	CM-PVS.81S	1SVR730794R2300		0.136 (0.300)
		CM-PVS.81P	1SVR740794R2300		0.128 (0.282)
3x160-300 V AC	Phase unbalance (Three-phase)	CM-PAS.31S	1SVR730774R1300		0.133 (0.293)
		CM-PAS.31P	1SVR740774R1300		0.124 (0.273)
		CM-PAS.41S	1SVR730774R3300		0.132 (0.291)
3x300-500 V AC	Phase unbalance (Three-phase)	CM-PAS.41P	1SVR740774R3300		0.123 (0.271)



CM-PSS.41P

2CDC 251 064 V0011



CM-PAS.31P

2CDC 251 063 V0011

¹⁾ The version with neutral monitoring is also suitable for monitoring single-phase mains. For this, all three external conductors (L1,L2,L3) have to be jumpered and connected as one single conductor.

²⁾ For applications where a reverse fed voltage >60% is expected, we recommend to use our three-phase monitoring relays for unbalance CM-PAS.xx

S: screw connection
P: push-in / easy connect

Three-phase monitoring relays

Ordering details - Multifunctional

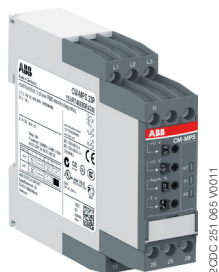

CM-MPS.23P

2CDC 251 065 V0011



CM-MPN.52P

2CDC 251 062 V0011

Ordering details

Rated control supply voltage = measuring voltage	DIP switch	Monitoring function	Neutral monitoring	Type	Order code	Price 1 pce	Weight (1 pce) kg (lb)
90-170 V AC		Multifunctional (Three-phase phase failure detection, Phase sequence monitoring, overvoltage, undervoltage, Phase unbalance)	■	CM-MPS.11S	1SVR730885R1300		0.148 (0.326)
180-280 V AC	☒			CM-MPS.11P	1SVR740885R1300		0.137 (0.302)
				CM-MPS.21S	1SVR730885R3300		0.146 (0.322)
				CM-MPS.21P	1SVR740885R3300		0.135 (0.298)
				CM-MPS.31S	1SVR730884R1300		0.142 (0.313)
3x160-300 V AC	☒			CM-MPS.31P	1SVR740884R1300		0.133 (0.293)
				CM-MPS.41S	1SVR730884R3300		0.140 (0.309)
3x300-500 V AC	☒			CM-MPS.41P	1SVR740884R3300		0.132 (0.291)
				CM-MPS.23S	1SVR730885R4300		0.149 (0.328)
180-280 V AC	☒			Multifunctional (Three-phase phase failure detection, Phase sequence monitoring, overvoltage, undervoltage, Phase unbalance)	■	CM-MPS.23P	1SVR740885R4300
3x300-500 V AC	☒	CM-MPS.43S	1SVR730884R4300				0.148 (0.327)
		CM-MPS.43P	1SVR740884R4300				0.137 (0.302)
3x350-580 V AC	☒	CM-MPN.52S	1SVR750487R8300				0.230 (0.507)
		CM-MPN.52P	1SVR760487R8300				0.226 (0.498)
3x450-720 V AC	☒	CM-MPN.62S	1SVR750488R8300				0.229 (0.505)
		CM-MPN.62P	1SVR760488R8300				0.225 (0.496)
3x530-820 V AC	☒	CM-MPN.72S	1SVR750489R8300				0.224 (0.494)
		CM-MPN.72P	1SVR760489R8300				0.220 (0.485)

S: screw connection

P: push-in / easy connect

- ☒ ON-delayed
- OFF-delayed
- ☐ Phase sequence monitoring activated
- ☐ Phase sequence monitoring deactivated
- ☐ Phase sequence correction activated
- ☐ Phase sequence correction deactivated
- ☐ 2x1 c/o (SPDT) contacts
- ☐ 1x2 c/o (SPDT) contacts

Three-phase monitoring relays

Function diagrams

2

Function diagrams - Phase failure detection CM-PBE

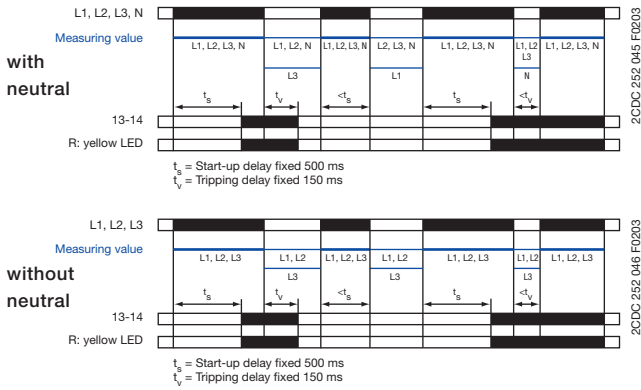

If all phases (and the neutral) are present, the output relay energizes after the start-up delay t_s is complete. If a phase failure occurs, the tripping delay t_v starts. When timing is complete, the output relay de-energizes. As soon as the voltage returns to the tolerance range, timing of t_s starts. When timing is complete, the output relay re-energizes automatically. The yellow LED glows when the output relay is energized.

Function diagrams - Phase failure under- / overvoltage detection CM-PVE

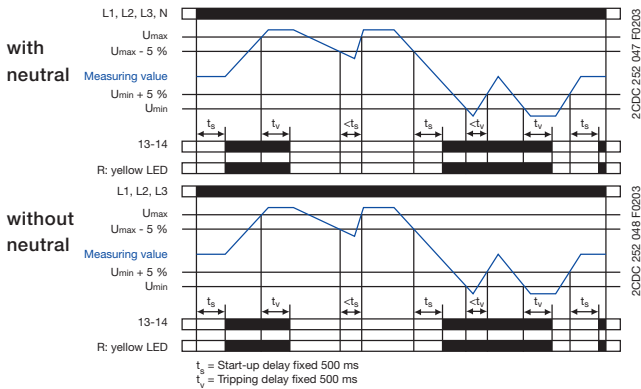

If all phases (and the neutral) are present with correct voltage, the output relay energizes after the start-up delay t_s is complete. If the voltage exceeds or falls below the fixed threshold value or if a phase failure occurs, the tripping delay t_v starts. When timing is complete, the output relay de-energizes. As soon as the voltage returns to the tolerance range, timing of t_s starts. When timing is complete, the output relay re-energizes automatically. The yellow LED glows when the output relay is energized.

Function diagram - Phase failure detection, phase sequence monitoring CM-PFE

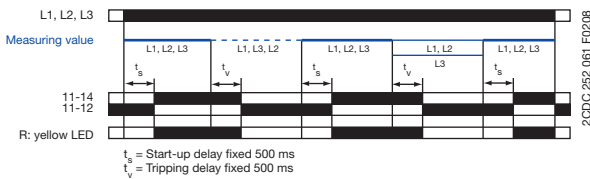

If all phases are present with the correct phase sequence, the output relay energizes after the start-up delay t_s is complete. If a phase failure or a phase sequence error occurs, the tripping delay t_v starts. When timing is complete, the output relay de-energizes. The yellow LED glows when the output relay is energized.

In case of motors which continue running with only two phases, the CM-PFE detects phase failure if the reverse fed voltage is less than 60 % of the originally applied voltage.

Function diagram - Phase failure detection, phase sequence monitoring CM-PFS

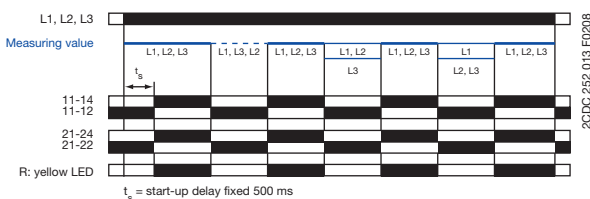

If all phases are present with the correct phase sequence, the output relay energizes after the start-up delay t_s is complete. If a phase failure or a phase sequence error occurs, the output relay de-energizes instantaneously. The yellow LED glows when the output relay is energized.

In case of motors which continue running with only two phases, the CM-PFS detects phase failure if the reverse fed voltage is less than 60 % of the originally applied voltage.

ATTENTION

If several CM-PFS units are placed side by side and the control supply voltage is higher than 415 V, spacing of at least 10 mm has to be kept between the individual units.

Three-phase monitoring relays

Function diagrams

CM-PSS.xx, CM-PVS.xx, CM.PAS.xx, CM-MPS.xx, CM-MPN.xx

Phase sequence monitoring and phase failure detection

Applying control supply voltage begins the fixed start-up delay t_{s1} . When t_{s1} is complete and all phases are present with correct voltage, the output relays energize and the yellow LED R/T glows.

Phase sequence monitoring

If phase sequence monitoring is activated, the output relays de-energize as soon as a phase sequence error occurs. The fault is displayed by alternated flashing of the LEDs F1 and F2. The output relays re-energize automatically as soon as the phase sequence is correct again.

Phase failure detection

The output relays de-energize instantaneous if a phase failure occurs. The fault is indicated by lighting of LED F1 and flashing of LED F2. The output relays re-energize automatically as soon as the voltage returns to the tolerance range.

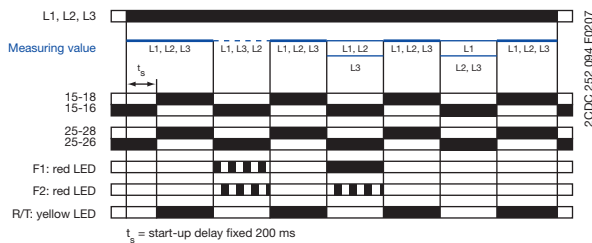

CM-MPS.11, CM-MPS.21, CM-MPS.23

Interrupted neutral monitoring

The interruption of the neutral in the main to be monitored is detected by means of phase unbalance evaluation.

Determined by the system, in case of unloaded neutral, i.e. symmetrical load between all three phases, it may happen that an interruption of the neutral will not be detected.

If the star point is displaced by asymmetrical load in the three-phase main, an interrupted neutral will be detected.

Displacement of the star point

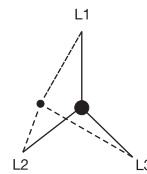

CM-MPS.x3, CM-MPN.x2

Automatic phase sequence correction

This function can be selected only if phase sequence monitoring is activated \square and operating mode 2x1 c/o (SPDT) contact \square is selected.

Applying control supply voltage begins the fixed start-up delay t_{s1} . When t_{s1} is complete and all phases are present with correct voltage, output relay R1 energizes. Output relay R2 energizes when the fixed start-up delay t_{s2} is complete and all phases are present with correct phase sequence. Output relay R2 remains de-energized if the phase sequence is incorrect.

If the voltage to be monitored exceeds or falls below the set threshold values for phase unbalance, over- or undervoltage or if a phase failure occurs, output relay R1 de-energizes and the LEDs F1 and F2 indicate the fault.

Output relay R2 is responsive only to a false phase sequence. In conjunction with a reversing contactor combination, this enables an automatic correction of the rotation direction. See circuit diagrams on the right.

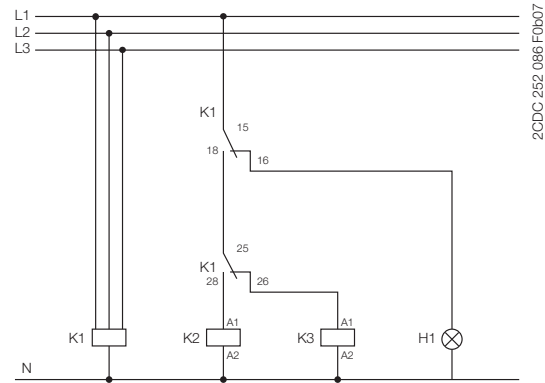
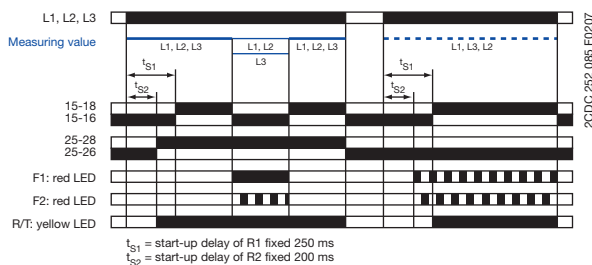

Control circuit diagram (K1 = CM-MPS.xx or CM-MPN.xx)

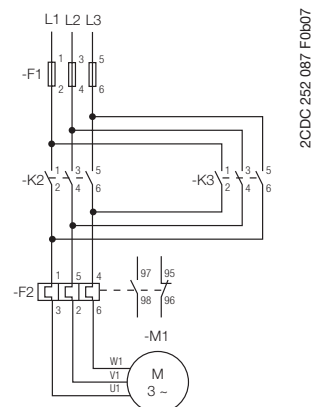

Power circuit diagram

Three-phase monitoring relays

Function diagrams

CM-PSS.xx¹, CM-PVS.xx², CM-MPS.xx², CM-MPN.xx²

Over- and undervoltage monitoring 1x2 c/o

Applying control supply voltage begins the fixed start-up delay t_s . When t_s is complete and all phases are present with correct voltage and with correct phase sequence, the output relays energize and the yellow LED R/T glows.

Type of tripping delay = ON-delay

If the voltage to be monitored exceeds or falls below the fixed¹ or set² threshold value, the output relays de-energize after the set tripping delay t_v is complete. The LED R/T flashes during timing and turns off as soon as the output relays de-energize.

The output relays re-energize automatically as soon as the voltage returns to the tolerance range, taking into account a fixed hysteresis of 5 % and the LED R/T glows.

Type of tripping delay = OFF-delay

If the voltage to be monitored exceeds or falls below the fixed¹ or set² threshold value, the output relays de-energize instantaneously and the LED R/T turns off.

As soon as the voltage returns to the tolerance range, taking into account a fixed hysteresis of 5 %, the output relays re-energize automatically after the set tripping delay t_v is complete. The LED R/T flashes during timing and turns steady when timing is complete.

ON-delay 1x2 c/o contacts 1x2 c/o

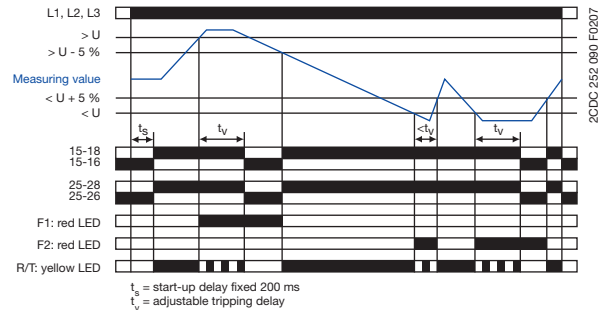

OFF-delay 1x2 c/o contacts 1x2 c/o

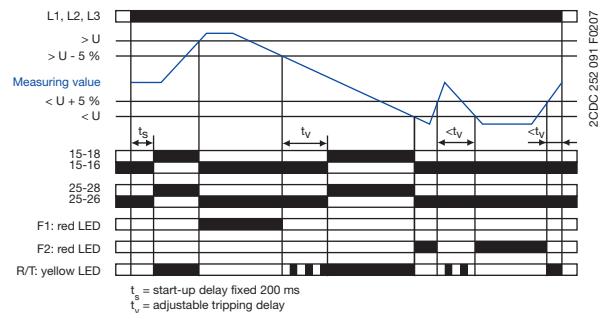

CM-MPS.x3, CM-MPN.x2

Over- and undervoltage monitoring 2x1 c/o

Applying control supply voltage begins the fixed start-up delay t_s . When t_s is complete and all phases are present with correct voltage and with correct phase sequence, the output relays energize. The yellow LED R/T glows as long as at least one output relay is energized.

Type of tripping delay = ON-delay

If the voltage to be monitored exceeds or falls below the set threshold value, output relay R1 (overvoltage) or output relay R2 (undervoltage) de-energizes after the set tripping delay t_v is complete. The LED R/T flashes during timing.

The corresponding output relay re-energizes automatically as soon as the voltage returns to the tolerance range, taking into account a fixed hysteresis of 5 %.

Type of tripping delay = OFF-delay

If the voltage to be monitored exceeds or falls below the set threshold value, output relay R1 (overvoltage) or output relay R2 (undervoltage) de-energizes instantaneously.

As soon as the voltage returns to the tolerance range, taking into account a fixed hysteresis of 5 %, the corresponding output relay re-energizes automatically after the set tripping delay t_v is complete. The LED R/T flashes during timing.

ON-delay 2x1 c/o contact 2x1 c/o

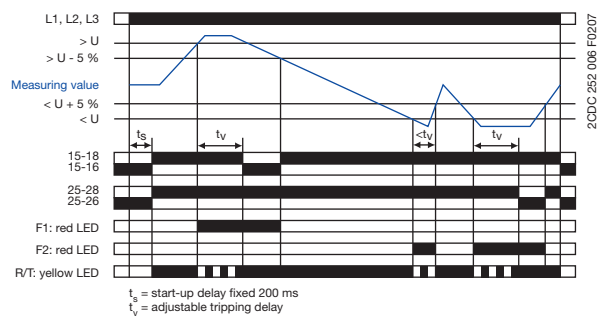

OFF-delay 2x1 c/o contact 2x1 c/o

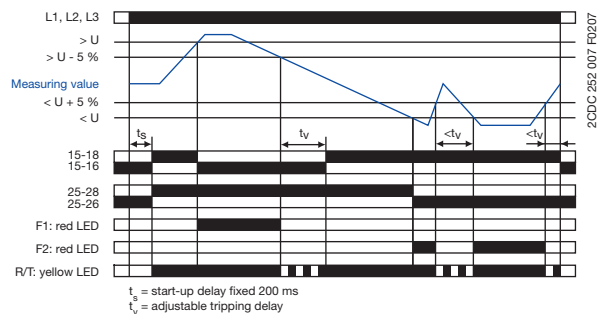

Three-phase monitoring relays

Function diagrams

CM-PAS.xx, CM-MPS.xx, CM-MPN.xx

Phase unbalance monitoring

Applying control supply voltage begins the fixed start-up delay t_s . When t_s is complete and all phases are present with correct voltage and with correct phase sequence, the output relays energize and the yellow LED R/T glows.

Type of tripping delay = ON-delay

If the voltage to be monitored exceeds or falls below the set phase unbalance threshold value, the output relays de-energize after the set tripping delay t_v is complete. The LED R/T flashes during timing and turns off as soon as the output relays de-energize.

The output relays re-energize automatically as soon as the voltage returns to the tolerance range, taking into account a fixed hysteresis of 20 % and the LED R/T glows.

Type of tripping delay = OFF-delay

If the voltage to be monitored exceeds or falls below the set phase unbalance threshold value, the output relays de-energize instantaneously and the LED R/T turns off.

As soon as the voltage returns to the tolerance range, taking into account a fixed hysteresis of 20 %, the output relays re-energize automatically after the set tripping delay t_v is complete. The LED R/T flashes during timing and turns steady when timing is complete.

ON-delay ☒

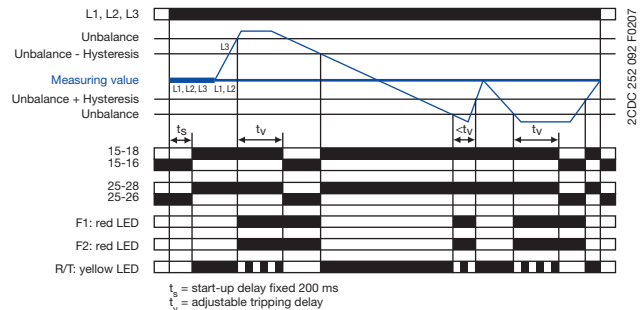

OFF-delay ■

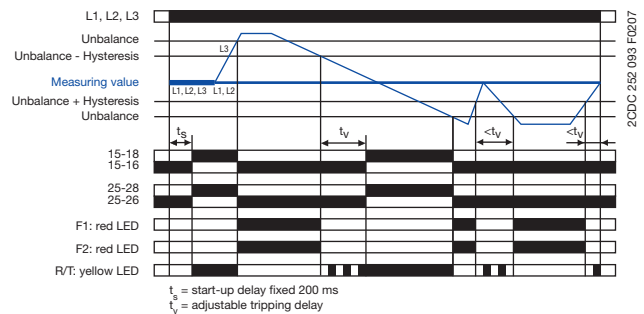

CM-PSS.xx, CM-PSV.xx, CM-PAS.xx, CM-MPS.xx, CM-MPN.xx
LED functions

Function	R/T: yellow LED	F1: red LED	F2: red LED
Control supply voltage applied, output relay energized		-	-
Tripping delay t_v active		-	-
Phase failure	-		
Phase sequence	-		
Overvoltage	-		-
Undervoltage	-	-	
Phase unbalance	-		
Interruption of the neutral	-		
Adjustment error ¹⁾			

¹⁾ Possible misadjustments of the front-face operating controls:

Overlapping of the threshold values: An overlapping of the threshold values is given, if the threshold value for overvoltage is set to a smaller value than the threshold value for undervoltage.

DIP switch 3 = OFF and DIP switch 4 = ON: Automatic phase sequence correction is activated and selected operating mode is 1x2 c/o contacts

DIP switch 2 and 4 = ON: Phase sequence detection is deactivated and the automatic phase sequence correction is activated

CM-PSS.xx, CM-PSV.xx, CM-PAS.xx, CM-MPS.xx, CM-MPN.xx
Type of tripping delay

The type of tripping delay ☒ / ■ can be adjusted via a rotary (CM-PxS.xx) or a DIP switch (CM-MPx.xx).

Switch position ON-delay ☒:

In case of a fault, the de-energizing of the output relays and the respective fault message are suppressed for the adjusted tripping delay t_v .

Switch position OFF-delay ■:

In case of a fault, the output relays de-energize instantaneously and a fault message is displayed and stored for the length of the adjusted tripping delay t_v . Thereby, also momentary undervoltage conditions are recognized.

Three-phase monitoring relays

Connection diagrams

2

Connection diagrams
CM-PBE, CM-PVE

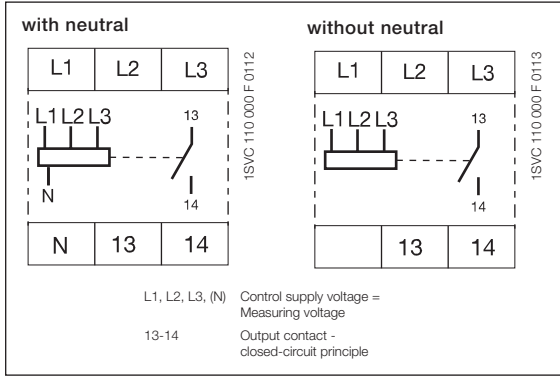

Connection diagram
CM-PVS.x1, CM-PSS.x1, CM-PAS.x1

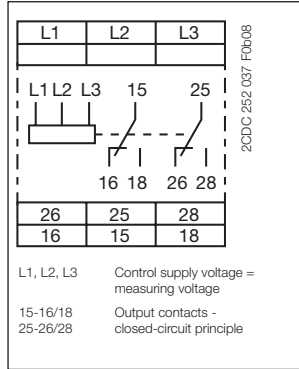

Connection diagram
CM-PFS

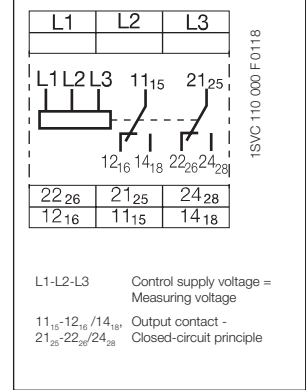

Connection diagram
CM-PFE

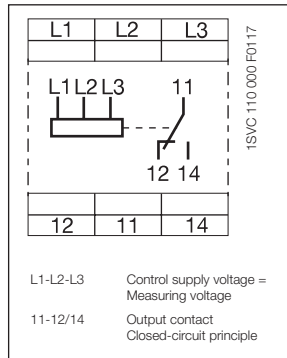

Connection diagram
CM-MPN.x2

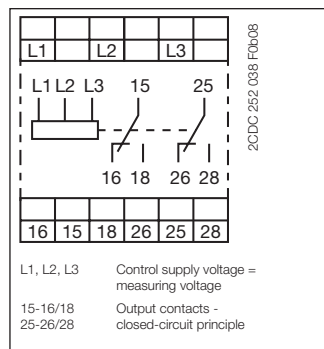

Connection diagram
CM-MPS.x1

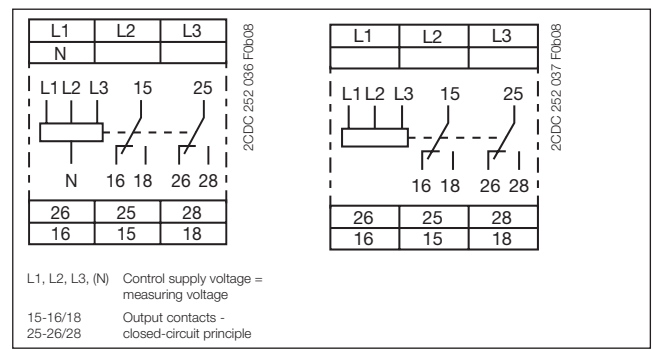

Connection diagram CM-MPS.x3

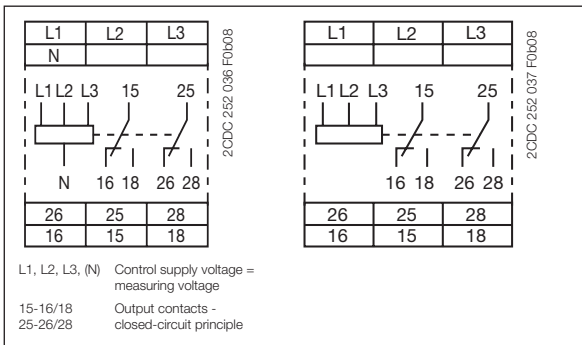

Three-phase monitoring relays DIP switches, Rotary switches

Rotary switch "Function" CM-PVS

	ON-delay with phase sequence monitoring
	OFF-delay with phase sequence monitoring
	ON-delay without phase sequence monitoring
	OFF-delay without phase sequence monitoring

Rotary switch "Function" CM-PSS

	ON-delay with phase sequence monitoring
	OFF-delay with phase sequence monitoring
	ON-delay without phase sequence monitoring
	OFF-delay without phase sequence monitoring

DIP switch functions CM-MPS.x3 and CM-MPN.x2

Position	4	3	2	1
ON ↑				
OFF				

2CDC 262 041 F0008

1 Timing function

ON ON-delayed
OFF OFF-delayed

3 Operating principle of output

ON 2x1 c/o contact
OFF 1x2 c/o contacts

2 Phase sequence monitoring

ON deactivated
OFF activated

4 Phase sequence correction

ON activated
OFF deactivated

¹⁾ Output relay R1 is responsive to overvoltage, output relay R2 is responsive to undervoltage. In case of other faults, both output relays react synchronously.

DIP switch functions CM-MPS.x1

Position	2	1
ON ↑		
OFF		

2CDC 262 040 F0008

1 Timing function

ON ON-delayed
OFF OFF-delayed

2 Phase sequence monitoring

ON deactivated
OFF activated

Three-phase monitoring relays

Technical data

2

Type	CM-PBE ¹⁾	CM-PBE	CM-PVE ¹⁾	CM-PVE	CM-PFE	CM-PFS
Supply circuit = measuring circuit	L1-L2-L3-N	L1-L2-L3	L1-L2-L3-N	L1-L2-L3	L1-L2-L3	
Rated control supply voltage U_s = measuring voltage	3x380-440 V AC, 220-240 V C	3x380-440 V AC	3x320-460 V AC, 185-265 V AC	3x320-460 V AC	3x208-440 V AC	3x200-500 V AC
Power consumption					approx. 15 VA	
Rated control supply voltage U_s tolerance	-15...+15 %		-15...+10 %		-10...+10 %	-15...+10 %
Rated frequency	50/60 Hz		50/60 Hz (-10...+10 %)			50/60 Hz
Duty time	100 %					
Measuring circuit	L1-L2-L3-N	L1-L2-L3	L1-L2-L3-N	L1-L2-L3	L1-L2-L3	
Monitoring functions	phase failure	■	■	■	■	■
	phase sequence	-	-	-	■	■
	over- / undervoltage	-	■	■	-	-
	neutral	■	-	■	-	-
Measuring ranges	3x380-440 V AC, 220-240 V AC	3x380-440 V AC	3x320-460 V AC, 185-265 V AC	3x320-460 V AC	3x208-440 V AC	3x200-500 V AC
Thresholds	U_{min}	0.6 x U_N	fixed 185 V / 320 V	fixed 320 V	0.6 x U_N	
	U_{max}		fixed 265 V / 460 V	fixed 460 V		
Hysteresis related to the threshold value	fixed 5 % (release value = 0.65 x U_N)		fixed 5 %		-	
Measuring voltage frequency	50/60 Hz (-10 %...+10 %)				50/60 Hz	
Response time	40 ms		80 ms		500 ms	
Accuracy within the rated control supply voltage tolerance	-				$\Delta U \leq 0.5 \%$	
Accuracy within the temperature range	-				$\Delta U \leq 0.06 \%$ / °C	
Timing circuit						
Start-up delay t_s	fixed 500 ms ($\pm 20 \%$)				fixed 500 ms	
Tripping t_v	fixed 150 ms ($\pm 20 \%$)		at over- / undervoltage fixed 500 ms ($\pm 20 \%$)		fixed 500 ms	-
Indication of operational states						
Relay status	R: yellow LED	Output relay energized				
Fault message	F: red LED	Only CM-PFS: Phase failure / Phase sequence error				
Output circuits	13-14				11-12/14	11(15)-12(16) / 14(18), 21(25)-22(26) / 24(28)
Kind of output	1 n/o contact				1 c/o contact	2 c/o contacts
Operating principle	closed-circuit principle ²⁾					
Contact material	AgCdO					AgNi allow, Cd free
Rated operational voltage U_o	IEC/EN 60947-1	250 V				250 V AC
Minimum switching voltage / Minimum switching current	- / -					
Maximum switching voltage	250 V AC, 250 V DC					
Rated operational current I_o (IEC/EN 60947-5-1)	AC12 (resistive) 230 V	4 A				
	AC15 (inductive) 230 V	3 A				
	DC12 (resistive) 24 V	4 A				
	DC13 (inductive) 24 V	2 A				
Mechanical lifetime	30 x 10 ⁶ switching cycles					
Electrical lifetime (AC12, 230 V, 4 A)	0.1 x 10 ⁶ switching cycles					
Max. fuse rating to achieve short-circuit protection	n/c contact	10 A fast-acting				6 A fast-acting
	n/o contact	10 A fast-acting				
AC rating (UL 508)	Utilization category (Control Circuit Rating Code)	B 300, CM-PFS: B300, pilot duty general purpose (250 V, 4 A, cos phi 0.75)				
	max. rated operational voltage	300 V AC				
	max. continuous thermal current at B 300	5 A				
	max. making/breaking apparent power at B 300	3600/360 VA				

¹⁾ Device with neutral monitoring: The external conductor voltage towards the neutral conductor is measured.

²⁾ Closed-circuit principle: Output relay is de-energized if the measured value exceeds/drops below the adjusted threshold.

Three-phase monitoring relays

Technical data

Type	CM-PBE ¹⁾	CM-PBE	CM-PVE ¹⁾	CM-PVE	CM-PFE	CM-PFS
General data						
Dimensions (W x H x D)	22.5 x 78 x 78.5 mm (0.89 x 3.07 x 3.09 in) CM-PFS: 22.5 x 78 x 100 mm (0.89 x 3.07 x 3.94 in)					
Weight	see data sheet					
Mounting	DIN rail (IEC/EN 60715)					
Mounting position	any					
Degree of protection	housing / terminals	IP50 / IP20				
Electrical connection						
Wire size	fine-strand with wire end ferrule	2 x 0.75-1.5 mm ² (2 x 18-16 AWG)				2 x 0.75-2.5 mm ²
	fine-strand without wire end ferrule	2 x 1-1.5 mm ² (2 x 18-16 AWG)				(2 x 8-14 AWG)
	rigid	2 x 0.75-1.5 mm ² (2 x 18-16 AWG)				2 x 0.5-4 mm ² (2 x 20-12 AWG)
Stripping length	10 mm (0.39 in)					7 mm (0.28 in)
Tightening torque	0.6-0.8 Nm					
Environmental data						
Ambient temperature range	operation / storage	-20...+60 °C / -40...+85 °C				-
Environmental testing (IEC 68-2-30)	24 h cycle time, 55 °C, 93 % rel., 96 h					-
Operational reliability (IEC 68-2-6)	6 g					-
Mechanical resistance (IEC 68-2-6)	10 g					-
Climatic category	IEC/EN 60721-3-3	-				3K3
Damp heat, cyclic	IEC/EN 60068-2-30	CM-PFS: 6 x 24 h cycle, 55 °C, 95 % RH				-
Vibration, sinusoidal	IEC/EN 60255-21-1	-				Class 2
Shock	IEC/EN 60255-21-2	-				Class 2
Isolation data						
Rated insulation voltage U _i (IEC/EN 60947-1, IEC/EN 60664-1)	between supply, measuring and output circuits	400 V				-
	supply circuit / output circuit	-				600 V
	output circuit 1 / output circuit 2	-				300 V
Rated impulse withstand voltage U _{imp} between all isolated circuits (VDE 0110, IEC 664)	supply circuit / output circuit	4 kV / 1.2 - 50 µs				-
	output circuit 1 / output circuit 2	-				6 kV
	output circuit 1 / output circuit 2	-				4 kV
Basic insulation for rated control supply voltage (IEC/EN 60664-1)	supply circuit / output circuit	-				600 V AC
Protective separation (IEC/EN 61140, EN 50178)	supply circuit / output circuit	-				n/a
Test voltage (routine test)	2.5 kV, 50 Hz, 1 min.					-
	supply circuit / output circuit	-				2.5 kV, 50 Hz, 1 min.
	output circuit 1 / output circuit 2	-				2.5 kV, 50 Hz, 1 min.
Pollution degree (IEC/EN 60664-1)	3					-
Overvoltage category (IEC/EN 60664-1)	III					-
Standards						
Product standard	IEC 255-6, EN 60255-6, CM-PFS: IEC/60255-1:2010					
Other standards	CM-PFS: EN 50178, IEC/EN 60204					
Low Voltage Directive	2006/95/EC					
EMC Directive	2004/108/EC					
RoHS Directive	CM-PFS: 2002/95/EC					
Electromagnetic compatibility						
Interference immunity to	EN 61000-6-2, CM-PFS: EN 61000-6-1, EN 61000-6-2					
electrostatic discharge	IEC/EN 61000-4-2	Level 3 - 6 kV/ 8 kV				-
radiated, radio-frequency, electromagnetic field	IEC/EN 61000-4-3	Level 3 - 10 V/m (1 GHz) / 3 V/m (2 GHz) / 1 V/m (2.7 GHz)				-
electrical fast transient / burst	IEC/EN 61000-4-4	Level 3 - 2 kV / 5 kHz				-
surge	IEC/EN 61000-4-5	Level 4 - 2 kV-L				-
conducted disturbances, induced by radio-frequency fields	IEC/EN 61000-4-6	Level 3 - 10 V				-
voltage dips, short interruptions and voltage variations	IEC/EN 61000-4-11	-				Class 3
harmonics and interharmonics	IEC/EN 61000-4-13	-				Class 3
Interference emission	EN 61000-6-4, CM-PFS:					
high-frequency radiated	IEC/CISPR 22, EN 55022	-				Class B
high-frequency conducted	IEC/CISPR 22, EN 55022	-				Class B

¹⁾ Device with neutral monitoring: The external conductor voltage towards the neutral conductor is measured.

Three-phase monitoring relays

Technical data

2

Type	CM-PSS.31	CM-PSS.41	CM-PVS.31	CM-PVS.41	CM-PVS.81	CM-PAS.31	CM-PAS.41																																																
Input circuit = Measuring circuit	L1, L2, L3																																																						
Rated control supply voltage U_s = measuring voltage	3x380 V AC	3x400 V AC	3x160-300 V AC	3x300-500 V AC	3x200-400 V AC	3x160-300 V AC	3x300-500 V AC																																																
Rated control supply voltage U_s tolerance	-15...+10 %																																																						
Rated frequency	50/60 Hz																																																						
Frequency range	45-65 Hz																																																						
Typical current / power consumption	25 mA / 18 VA (380 V AC)	25 mA / 18 VA (400 V AC)	25 mA / 10 VA (230 V AC)	25 mA / 18 VA (400 V AC)	19 mA / 10 VA (300 V AC)	25 mA / 10 VA (230 V AC)	25 mA / 18 VA (400 V AC)																																																
Measuring circuit	L1, L2, L3																																																						
Monitoring functions	<table border="0" style="width: 100%; border-collapse: collapse;"> <tr> <td style="width: 15%;"></td> <td style="width: 15%;">Phase failure</td> <td style="width: 15%;">■</td> <td style="width: 15%;">■</td> <td style="width: 15%;">■</td> <td style="width: 15%;">■</td> <td style="width: 15%;">■</td> <td style="width: 15%;">■</td> </tr> <tr> <td></td> <td>Phase sequence</td> <td colspan="6">can be switched off</td> </tr> <tr> <td></td> <td>Automatic phase sequence correction</td> <td>-</td> <td>-</td> <td>-</td> <td>-</td> <td>-</td> <td>-</td> </tr> <tr> <td></td> <td>Over- / undervoltage</td> <td>■</td> <td>■</td> <td>■</td> <td>■</td> <td>■</td> <td>-</td> </tr> <tr> <td></td> <td>Phase unbalance</td> <td>-</td> <td>-</td> <td>-</td> <td>-</td> <td>-</td> <td>■</td> </tr> <tr> <td></td> <td>Neutral</td> <td>-</td> <td>-</td> <td>-</td> <td>-</td> <td>-</td> <td>-</td> </tr> </table>								Phase failure	■	■	■	■	■	■		Phase sequence	can be switched off							Automatic phase sequence correction	-	-	-	-	-	-		Over- / undervoltage	■	■	■	■	■	-		Phase unbalance	-	-	-	-	-	■		Neutral	-	-	-	-	-	-
	Phase failure	■	■	■	■	■	■																																																
	Phase sequence	can be switched off																																																					
	Automatic phase sequence correction	-	-	-	-	-	-																																																
	Over- / undervoltage	■	■	■	■	■	-																																																
	Phase unbalance	-	-	-	-	-	■																																																
	Neutral	-	-	-	-	-	-																																																
Measuring range	<table border="0" style="width: 100%; border-collapse: collapse;"> <tr> <td style="width: 15%;"></td> <td style="width: 15%;">Overvoltage</td> <td style="width: 15%;">3x418 V AC</td> <td style="width: 15%;">3x440 V AC</td> <td style="width: 15%;">3x220-300 V AC</td> <td style="width: 15%;">3x420-500 V AC</td> <td style="width: 15%;">3x300-400 V AC</td> <td style="width: 15%;">-</td> </tr> <tr> <td></td> <td>Undervoltage</td> <td>3x342 V AC</td> <td>3x360 V AC</td> <td>3x160-230 V AC</td> <td>3x300-380 V AC</td> <td>3x210-300 V AC</td> <td>-</td> </tr> <tr> <td></td> <td>Phase unbalance</td> <td>-</td> <td>-</td> <td>-</td> <td>-</td> <td>-</td> <td>2-25 % of average of phase voltages</td> </tr> </table>								Overvoltage	3x418 V AC	3x440 V AC	3x220-300 V AC	3x420-500 V AC	3x300-400 V AC	-		Undervoltage	3x342 V AC	3x360 V AC	3x160-230 V AC	3x300-380 V AC	3x210-300 V AC	-		Phase unbalance	-	-	-	-	-	2-25 % of average of phase voltages																								
	Overvoltage	3x418 V AC	3x440 V AC	3x220-300 V AC	3x420-500 V AC	3x300-400 V AC	-																																																
	Undervoltage	3x342 V AC	3x360 V AC	3x160-230 V AC	3x300-380 V AC	3x210-300 V AC	-																																																
	Phase unbalance	-	-	-	-	-	2-25 % of average of phase voltages																																																
Thresholds	<table border="0" style="width: 100%; border-collapse: collapse;"> <tr> <td style="width: 15%;"></td> <td style="width: 15%;">Overvoltage</td> <td style="width: 15%;">fixed</td> <td style="width: 15%;">-</td> <td style="width: 15%;">adjustable within measuring range</td> <td style="width: 15%;">-</td> <td style="width: 15%;">-</td> <td style="width: 15%;">-</td> </tr> <tr> <td></td> <td>Undervoltage</td> <td>fixed</td> <td>-</td> <td>adjustable within measuring range</td> <td>-</td> <td>-</td> <td>-</td> </tr> <tr> <td></td> <td>Phase unbalance (switch-off value)</td> <td>-</td> <td>-</td> <td>-</td> <td>-</td> <td>-</td> <td>adjust. within meas. range</td> </tr> </table>								Overvoltage	fixed	-	adjustable within measuring range	-	-	-		Undervoltage	fixed	-	adjustable within measuring range	-	-	-		Phase unbalance (switch-off value)	-	-	-	-	-	adjust. within meas. range																								
	Overvoltage	fixed	-	adjustable within measuring range	-	-	-																																																
	Undervoltage	fixed	-	adjustable within measuring range	-	-	-																																																
	Phase unbalance (switch-off value)	-	-	-	-	-	adjust. within meas. range																																																
Hysteresis related to the threshold value	<table border="0" style="width: 100%; border-collapse: collapse;"> <tr> <td style="width: 15%;"></td> <td style="width: 15%;">Over- / undervoltage</td> <td style="width: 15%;">fixed 5 %</td> <td style="width: 15%;">-</td> <td style="width: 15%;">-</td> <td style="width: 15%;">-</td> <td style="width: 15%;">-</td> <td style="width: 15%;">-</td> </tr> <tr> <td></td> <td>Phase unbalance</td> <td>-</td> <td>-</td> <td>-</td> <td>-</td> <td>-</td> <td>fixed 20 %</td> </tr> </table>								Over- / undervoltage	fixed 5 %	-	-	-	-	-		Phase unbalance	-	-	-	-	-	fixed 20 %																																
	Over- / undervoltage	fixed 5 %	-	-	-	-	-																																																
	Phase unbalance	-	-	-	-	-	fixed 20 %																																																
Rated frequency of the measuring signal	50/60 Hz																																																						
Frequency range of the measuring signal	45-65 Hz																																																						
Maximum measuring cycle time	100 ms																																																						
Accuracy within the rated control supply voltage tolerance	$\Delta U \leq 0.5 \%$																																																						
Accuracy within the temperature range	$\Delta U \leq 0.06 \% / ^\circ\text{C}$																																																						
Measuring method	True RMS																																																						
Timing circuit																																																							
Start-up delay t_s	fixed 200 ms																																																						
Tripping delay t_v	ON- or OFF-delay 0; 0.1-30 s adjustable					ON- delay 0; 0.1-30 s adjustable																																																	
Repeat accuracy (constant parameters)	- w 0.2 %																																																						
Accuracy within the rated control supply voltage tolerance	$\Delta t \leq 0.5 \%$																																																						
Accuracy within the temperature range	$\Delta t \leq 0.06 \% / ^\circ\text{C}$																																																						
Indication of operational states	Details see function description / -diagrams		1 yellow LED, 2 red LED's			Details see function description / -diagrams																																																	
Output circuits	15-16/18, 25-26/28																																																						
Kind of output	relay, 2 x 1 c/o contact																																																						
Operating principle	closed-circuit principle ¹⁾																																																						
Contact material	AgNi alloy, Cd free																																																						
Rated operational voltage U_o	IEC/EN 60947-1 250 V																																																						
Minimum switching power	24 V / 10 mA																																																						
Maximum switching voltage	see load limit curve																																																						

¹⁾ Closed-circuit principle: Output relay(s) de-energize(s) if measured value exceeds or falls below the adjusted threshold value

Three-phase monitoring relays

Technical data

2

Type		CM-PSS.31	CM-PSS.41	CM-PVS.31	CM-PVS.41	CM-PVS.81	CM-PAS.31	CM-PAS.41
Rated operational current I _o (IEC/EN 60947-5-1)	AC12 (resistive) 230 V	4 A						
	AC15 (inductive) 230 V	3 A						
	DC12 (resistive) 24 V	4 A						
	DC13 (inductive) 24 V	2 A						
AC rating (UL 508)	Utilization category (Control Circuit Rating Code)	B 300						
	max. rated operational voltage	300 V AC						
	max. continuous thermal current at B 300	5 A						
	max. making/breaking apparent power at B 300	3600/360 VA						
Mechanical lifetime		30 x 10 ⁶ switching cycles						
Electrical lifetime (AC12, 230 V, 4 A)		0.1 x 10 ⁶ switching cycles						
Max. fuse rating to achieve short- circuit protection	n/c contact	6 A fast-acting						
	n/o contact	10 A fast-acting						

General data

MTBF		on request
Duty time		100%
Dimensions (W x H x D)	product dimensions	22.5 x 85.6 x 103.7 mm (0.89 x 3.37 x 4.08 in)
	packaging dimensions	97 x 109 x 30 mm (3.82 x 4.29 x 1.18 in)
Weight		depending on device, see ordering details
Mounting		DIN rail (IEC/EN 60715), snap-on mounting without any tool
	Mounting position	any
Minimum distance to other units	vertical / horizontal	not necessary / not necessary
Material of housing		UL 94 V-0
Degree of protection	housing / terminals	IP50 / IP20

Electrical connection

Wire size		Screw connection technology	Easy Connect Technology (Push-in)
fine-strand with(out) wire end ferrule		1 x 0.5-2.5 mm ² (1 x 20-14 AWG)	2 x 0.5-1.5 mm ² (2 x 20-16 AWG)
		2 x 0.5-1.5 mm ² (2 x 20-16 AWG)	
	rigid	1 x 0.5-4 mm ² (1 x 20-12 AWG)	2 x 0.5-1.5 mm ² (2 x 20-16 AWG)
		2 x 0.5-2.5 mm ² (2 x 20-14 AWG)	
Stripping length		8 mm (0.32 in)	
Tightening torque		0.6-0.8 Nm (5.31-7.08 lb.in)	-
Environmental data			
Ambient temperature ranges	operation / storage	-25...+60 °C / -40...+85 °C	
Damp heat (IEC 60068-2-30)		55 °C, 6 cycles	
Climatic category		3K3	
Vibration (sinusoidal) (IEC/EN 60255-21-1)		Class 2	
Shock (IEC/EN 60255-21-2)		Class 2	

Isolation data

Rated insulation voltage U _i	input circuit / output circuit	600 V
	output circuit 1 / output circuit 2	300 V
Rated impulse withstand voltage U _{imp} (VDE 0110, IEC/EN 60664)	input circuit	6 kV; 1.2/50 μs
	output circuit	4 kV; 1.2/50 μs
Test voltage between all isolated circuits (routine test)		2.5 kV, 50 Hz, 1 s
Basic insulation	input circuit / output circuit	600 V
Protective separation (VDE 0106 part 101 and 101/A, IEC/EN 1140)	input circuit / output circuit	-
Pollution degree (VDE 0110, IEC/EN 60664)		3
Overvoltage category (VDE 0110, IEC 60664)		III

Standards

Product standard	IEC/EN 60255-6, EN 50178
Low Voltage Directive	2006/95/EC
EMC directive	2004/108/EC
RoHS directive	2002/95/EC

Electromagnetic compatibility

Interference immunity to		
electrostatic discharge	IEC/EN 61000-4-2	EN 61000-6-1, EN 61000-6-2 Level 3 (6 kV / 8 kV)
radiated, radio-frequency, electromagnetic field	IEC/EN 61000-4-3	Level 3 (10 V/m)
electrical fast transient / burst	IEC/EN 61000-4-4	Level 3 (2 kV / 2 kHz)
surge	IEC/EN 61000-4-5	Level 4 (2 kV L-L)
conducted disturbances, induced by radio-frequency fields	IEC/EN 61000-4-6	Level 3 (10 V)
Interference emission		
high-frequency radiated	IEC/CISPR 22, EN 55022	EN 61000-6-3, EN 61000-6-4
high-frequency conducted	IEC/CISPR 22, EN 55022	Class B

Three-phase monitoring relays

Technical data

2

Type	CM-MPS.11	CM-MPS.21	CM-MPS.31	CM-MPS.41
Input circuit = Measuring circuit	L1, L2, L3, N		L1, L2, L3	
Rated control supply voltage U_s = measuring voltage	3x90-170 V AC	3x180-280 V AC	3x160-300 V AC	3x300-500 V AC
Rated control supply voltage U_s tolerance	-15...+10 %			
Rated frequency	50/60 Hz			
Frequency range	45-65 Hz			
Typical current / power consumption	25 mA / 10 VA (115 V AC)	25 mA / 18 VA (230 V AC)	25 mA / 10 VA (230 V AC)	25 mA / 18 VA (400 V AC)
Measuring circuit	L1, L2, L3, N		L1, L2, L3	
Monitoring functions	Phase failure Phase sequence Automatic phase sequence correction Over- / undervoltage Phase unbalance Interrupted neutral	■ ■ - ■ ■ ■	■ ■ - ■ ■ -	■ ■ - ■ ■ -
Measuring range	Overvoltage Undervoltage Phase unbalance	3x120-170 V AC 3x90-130 V AC 2-25 % of average of phase voltages	3x240-280 V AC 3x180-220 V AC 3x160-230 V AC	3x420-500 V AC 3x300-380 V AC
Thresholds	Overvoltage Undervoltage Phase unbalance (switch-off value)	adjustable within measuring range adjustable within measuring range adjustable within measuring range	adjustable within measuring range	
Hysteresis related to the threshold value	Over- / undervoltage Phase unbalance	fixed 5 % fixed 20 %		
Rated frequency of the measuring signal	50/60 Hz			
Frequency range of the measuring signal	45-65 Hz			
Maximum measuring cycle time	100 ms			
Accuracy within the rated control supply voltage tolerance	$\Delta U \leq 0.5 \%$			
Accuracy within the temperature range	$\Delta U \leq 0.06 \% / ^\circ\text{C}$			
Measuring method	True RMS			
Timing circuit				
Start-up delay t_s	fixed 200 ms			
Tripping delay t_v	ON- or OFF-delay 0; 0.1-30 s adjustable			
Accuracy within the rated control supply voltage tolerance	$\Delta t \leq 0.5 \%$			
Accuracy within the temperature range	$\Delta t \leq 0.06 \% / ^\circ\text{C}$			
Indication of operational states	Details see function description / -diagrams			
Output circuits	15-16/18, 25-26/28			
Kind of output	relay, 1 x 2 c/o contacts			
Operating principle	closed-circuit principle ¹⁾			
Contact material	AgNi alloy, Cd free			
Rated operational voltage U_o (IEC/EN 60947-1)	250 V			
Minimum switching power	24 V / 10 mA			
Maximum switching voltage	see load limit curve			
Rated operational current I_o (IEC/EN 60947-5-1)	AC12 (resistive) 230 V AC15 (inductive) 230 V DC12 (resistive) 24 V DC13 (inductive) 24 V	4 A 3 A 4 A 2 A		
AC rating (UL 508)	Utilization category (Control Circuit Rating Code)	B 300		
	max. rated operational voltage max. continuous thermal current at B 300 max. making/breaking apparent power at B 300	300 V AC 5 A 3600/360 VA		
Mechanical lifetime	30 x 10 ⁶ switching cycles			
Electrical lifetime (AC12, 230 V, 4 A)	0,1 x 10 ⁶ switching cycles			
Max. fuse rating to achieve short-circuit protection	n/c contact n/o contact	6 A fast-acting 10 A fast-acting		

¹⁾ Closed-circuit principle: Output relay(s) de-energize(s) if measured value exceeds or falls below the adjusted threshold value

Three-phase monitoring relays

Technical data

Type		CM-MPS.11	CM-MPS.21	CM-MPS.31	CM-MPS.41
General data					
MTBF		on request			
Duty time		100%			
Dimensions (W x H x D)	product dimensions	22.5 x 85.6 x 103.7 mm (0.89 x 3.37 x 4.08 in)			
	packaging dimensions	97 x 109 x 30 mm (3.82 x 4.29 x 1.18 in)			
Weight		Screw connection technology		Easy Connect Technology (Push-in)	
	net weight	depending on device, see ordering details			
	gross weight	depending on device, see ordering details			
Mounting		DIN rail (IEC/EN 60715), snap-on mounting without any tool			
Mounting position		any			
Minimum distance to other units	vertical / horizontal	not necessary / not necessary			
Material of housing		UL 94 V-0			
Degree of protection	housing / terminals	IP50 / IP20			
Electrical connection					
Wire size		Screw connection technology		Easy Connect Technology (Push-in)	
	fine-strand with(out) wire end ferrule	1 x 0.5-2.5 mm ² (1 x 20-14 AWG) 2 x 0.5-1.5 mm ² (2 x 20-16 AWG)		2 x 0.5-1.5 mm ² (2 x 20-16 AWG)	
	rigid	1 x 0.5-4 mm ² (1 x 20-12 AWG) 2 x 0.5-2.5 mm ² (2 x 20-14 AWG)		2 x 0.5-1.5 mm ² (2 x 20-16 AWG)	
Stripping length		8 mm (0.32 in)			
Tightening torque		0.6-0.8 Nm (5.31-7.08 lb.in)		-	
Environmental data					
Ambient temperature ranges	operation / storage	-25...+60 °C / -40...+85 °C			
Damp heat (IEC 60068-2-30)		55 °C, 6 cycles			
Climatic category		3K3			
Vibration (sinusoidal) (IEC/EN 60255-21-1)		Class 2			
Shock (IEC/EN 60255-21-2)		Class 2			
Isolation data					
Rated insulation voltage U _i	input circuit / output circuit	600 V			
	output circuit 1 / output circuit 2	300 V			
Rated impulse withstand voltage U _{imp} (VDE 0110, IEC/EN 60664)	input circuit	6 kV; 1.2/50 µs			
	output circuit	4 kV; 1.2/50 µs			
Test voltage between all isolated circuits (routine test)		2.5 kV, 50 Hz, 1 s			
Basic insulation	input circuit / output circuit	600 V			
Protective separation (VDE 0106 part 101 and 101/A, IEC/EN 61140)	input circuit / output circuit	yes		-	
Pollution degree (VDE 0110, IEC/EN 60664)		3			
Overvoltage category (VDE 0110, IEC 60664)		III			
Standards					
Product standard		IEC/EN 60255-6, EN 50178			
Low Voltage Directive		2006/95/EC			
EMC directive		2004/108/EC			
RoHS directive		2002/95/EC			
Electromagnetic compatibility					
Interference immunity to		EN 61000-6-1, EN 61000-6-2			
electrostatic discharge	IEC/EN 61000-4-2	Level 3 (6 kV / 8 kV)			
radiated, radio-frequency, electromagnetic field	IEC/EN 61000-4-3	Level 3 (10 V/m)			
electrical fast transient / burst	IEC/EN 61000-4-4	Level 3 (2 kV / 2 kHz)			
surge	IEC/EN 61000-4-5	Level 4 (2 kV L-L)			
conducted disturbances, induced by radio-frequency fields	IEC/EN 61000-4-6	Level 3 (10 V)			
harmonics and interharmonics	IEC/EN 61000-4-13	Class 3			
Interference emission		EN 61000-6-3, EN 61000-6-4			
high-frequency radiated	IEC/CISPR 22, EN 55022	Class B			
high-frequency conducted	IEC/CISPR 22, EN 55022	Class B			

Three-phase monitoring relays

Technical data

2

Type	CM-MPS.23	CM-MPS.43	CM-MPN.52	CM-MPN.62	CM-MPN.72
Input circuit = Measuring circuit	L1, L2, L3, N		L1, L2, L3		
Rated control supply voltage U_s = measuring voltage	3x180-280 V AC	3x300-500 V AC	3x350-580 V AC	3x450-720 V AC	3x530-820 V AC
Rated control supply voltage U_s tolerance	-15...+10 %				
Rated frequency	50/60/400 Hz		50/60 Hz		
Frequency range	45-440 Hz		45-65 Hz		
Typical current / power consumption	5 mA / 4 VA (230 V AC)	5 mA / 4 VA (400 V AC)	29 mA / 41 VA (480 V AC)	29 mA / 52 VA (600 V AC)	29 mA / 59 VA (690 V AC)
Measuring circuit	L1, L2, L3, N		L1, L2, L3		
Monitoring functions	Phase failure <input type="checkbox"/> <input type="checkbox"/> <input type="checkbox"/> <input type="checkbox"/> <input type="checkbox"/> Phase sequence can be switched off Automatic phase sequence correction configurable Over- / undervoltage <input type="checkbox"/> <input type="checkbox"/> <input type="checkbox"/> <input type="checkbox"/> <input type="checkbox"/> Phase unbalance <input type="checkbox"/> <input type="checkbox"/> <input type="checkbox"/> <input type="checkbox"/> <input type="checkbox"/> Interrupted neutral <input type="checkbox"/> <input type="checkbox"/> <input type="checkbox"/> <input type="checkbox"/> <input type="checkbox"/>				
Measuring range	Overvoltage 3x240-280 V AC 3x420-500 V AC 3x480-580 V AC 3x600-720 V AC 3x690-820 V AC Undervoltage 3x180-220 V AC 3x300-380 V AC 3x350-460 V AC 3x450-570 V AC 3x530-660 V AC				
Thresholds	Phase unbalance 2-25 % of average of phase voltages Overvoltage adjustable within measuring range Undervoltage adjustable within measuring range Phase unbalance (switch-off value) adjustable within measuring range				
Hysteresis related to the threshold value	Over- / undervoltage fixed 5 % Phase unbalance fixed 20 %				
Rated frequency of the measuring signal	50/60/400 Hz		50/60 Hz		
Frequency range of the measuring signal	45-440 Hz		45-65 Hz		
Maximum measuring cycle time	100 ms				
Accuracy within the rated control supply voltage tolerance	$\Delta U \leq 0.5 \%$				
Accuracy within the temperature range	$\Delta U \leq 0.06 \% / ^\circ\text{C}$				
Measuring method	True RMS				
Timing circuit	15-16/18, 25-26/28				
Start-up delay t_s and t_{s2}	fixed 200 ms				
Start-up delay t_{s1}	fixed 250 ms				
Tripping delay t_v	ON- or OFF-delay 0; 0.1-30 s adjustable				
Accuracy within the rated control supply voltage tolerance	$\Delta t \leq 0.5 \%$				
Accuracy within the temperature range	$\Delta t \leq 0.06 \% / ^\circ\text{C}$				
Indication of operational states	Details see function description / -diagrams				
Output circuits	15-16/18, 25-26/28				
Kind of output	relay, 2 x 1 or 1 x 2 c/o contacts configurable				
Operating principle	closed-circuit principle ¹⁾				
Contact material	AgNi alloy, Cd free				
Rated operational voltage U_o	IEC/EN 60947-1 250 V				
Minimum switching power	24 V / 10 mA				
Maximum switching voltage	see load limit curve				
Rated operational current I_o (IEC/EN 60947-5-1)	AC12 (resistive) 230 V	4 A			
	AC15 (inductive) 230 V	3 A			
	DC12 (resistive) 24 V	4 A			
	DC13 (inductive) 24 V	2 A			
AC rating (UL 508)	Utilization category (Control Circuit Rating Code)	B 300			
	max. rated operational voltage	300 V AC			
	max. continuous thermal current at B 300	5 A			
	max. making/breaking apparent power at B 300	3600/360 VA			
Mechanical lifetime	30 x 10 ⁶ switching cycles				
Electrical lifetime (AC12, 230 V, 4 A)	0.1 x 10 ⁶ switching cycles				
Max. fuse rating to achieve short-circuit protection	n/c contact	6 A fast-acting	10 A fast-acting		
	n/o contact	10 A fast-acting			

¹⁾ Closed-circuit principle: Output relay(s) de-energize(s) if measured value exceeds or falls below the adjusted threshold value

Three-phase monitoring relays

Technical data

Type	CM-MPS.23	CM-MPS.43	CM-MPN.52	CM-MPN.62	CM-MPN.72
General data					
MTBF	on request				
Duty time	100%				
Dimensions (W x H x D)	product dimensions				
	22.5 x 85.6 x 103.7 mm (0.89 x 3.37 x 4.08 in)				
Weight	packaging dimensions				
	97 x 109 x 30 mm (3.82 x 4.29 x 1.18 in)				
Mounting	depending on device, see ordering details				
Mounting position	DIN rail (IEC/EN 60715), snap-on mounting without any tool				
Minimum distance to other units	vertical / horizontal	not necessary / not necessary			
Material of housing	UL 94 V-0				
Degree of protection	housing / terminals	IP50 / IP20			
Electrical connection					
Wire size	fine-strand with(out) wire end ferrule	Screw connection technology		Easy Connect Technology (Push-in)	
		1 x 0.5-2.5 mm ² (1 x 20-14 AWG) 2 x 0.5-1.5 mm ² (2 x 20-16 AWG)		2 x 0.5-1.5 mm ² (2 x 20-16 AWG)	
Stripping length	rigid	1 x 0.5-4 mm ² (1 x 20-12 AWG) 2 x 0.5-2.5 mm ² (2 x 20-14 AWG)		2 x 0.5-1.5 mm ² (2 x 20-16 AWG)	
		8 mm (0.32 in)			
Tightening torque	0.6-0.8 Nm (5.31-7.08 lb.in)				-
Environmental data					
Ambient temperature ranges	operation / storage	-25...+60 °C / -40...+85 °C			
Damp heat (IEC 60068-2-30)	55 °C, 6 cycles				
Climatic category	3K3				
Vibration (sinusoidal) (IEC/EN 60255-21-1)	Class 2				
Shock (IEC/EN 60255-21-2)	Class 2				
Isolation data					
Rated insulation voltage U _i	input circuit / output circuit	600 V		1000 V	
	output circuit 1 / 2	300 V			
Rated impulse withstand voltage U _{imp} (VDE 0110, IEC/EN 60664)	input circuit	6 kV; 1.2/50 μs		8 kV; 1.2/50 μs	
	output circuit	4 kV; 1.2/50 μs			
Test voltage (routine test) between	isolated output circuits	2.5 kV, 50 Hz, 1 s			
	input circuit and isolated output circuits	2.5 kV, 50 Hz, 1 s		4 kV, 50 Hz, 1 s	
Basic insulation	input circuit / output circuit	600 V		1000 V	
Protective separation (VDE 0106 part 101 and 101/A, IEC/EN 61140)	input circuit / output circuit	-			
Pollution degree (VDE 0110, IEC/EN 60664)	3				
Overvoltage category (VDE 0110, IEC 60664)	III				
Standards					
Product standard	IEC/EN 60255-6, EN 50178				
Low Voltage Directive	2006/95/EC				
EMC directive	2004/108/EC				
RoHS directive	2002/95/EC				
Electromagnetic compatibility					
Interference immunity to	EN 61000-6-1, EN 61000-6-2				
electrostatic discharge	IEC/EN 61000-4-2	Level 3 (6 kV / 8 kV)			
	IEC/EN 61000-4-3	Level 3 (10 V/m)			
radiated, radio-frequency, electromagnetic field					
electrical fast transient / burst	IEC/EN 61000-4-4	Level 3 (2 kV / 2 kHz)			
surge	IEC/EN 61000-4-5	Level 4 (2 kV L-N) ; Level 4 (2 kV L-L)			
conducted disturbances, induced by radio-frequency fields	IEC/EN 61000-4-6	Level 3 (10 V)			
harmonics and interharmonics	IEC/EN 61000-4-13	Class 3			
Interference emission	EN 61000-6-3, EN 61000-6-4				
high-frequency radiated	IEC/CISPR 22, EN 55022	Class B			
high-frequency conducted	IEC/CISPR 22, EN 55022	Class B			

Grid feeding monitoring relays - Voltage and frequency monitoring functions Product group picture

2



Grid feeding monitoring relays - Voltage and frequency monitoring functions Table of contents

Grid feeding monitoring relays - Voltage and frequency monitoring functions	
Product group picture	49
Table of contents	50
Benefits and advantages, applications	51
Operating controls - CM-UFD.Mxx	52
Operating controls - CM-UFS.1	53
Applications	54
Ordering and selection	55
Functional diagrams - CM-UFS.1	56
Connection diagrams	57
Technical data - CM-UFD.Mxx	58
Technical data - CM-UFS.1	63

Grid feeding monitoring relays - Voltage and frequency monitoring functions

Benefits and advantages, Applications

2

Characteristics CM-UFD.M22

- Monitoring of voltage and frequency in single- and three-phase mains 2-wire, 3-wire or 4-wire
- Type tested in accordance to CEI 0-21
- Over- and undervoltage, 10 minutes average value as well as over- and underfrequency monitoring
- Two-level threshold settings for over-/undervoltage and frequency
- ROCOF (rate of change of frequency) monitoring configurable
- Integrated management of redundancy function (acc. CEI 0-21, mandatory in plants with $P > 20$ kW)
- Measured values, thresholds and settings shown on the display
- All threshold values adjustable as absolute values
- Default setting according to CEI 0-21
- True RMS measuring principle
- High measurement accuracy
- 3 control inputs for remote trip, feedback signal, and external signal
- Tripping delay for each threshold adjustable
- Interrupted neutral detection
- Error memory for up to 99 entries (incl. cause of error, measured value, relative timestamp)
- Autotest function
- Password setting protection
- 3 c/o (SPDT) contacts
- LEDs for the indication of operational states

Characteristics CM-UFS.1

- Monitoring of three-phase mains for grid feeding
- Type-tested in accordance with DIN V VDE V 0126-1-1: February 2006
- Neutral conductor connection configurable
- Can also be used to monitor single-phase mains
- Threshold value for the 10 minutes average value adjustable (110-115% of U_N)
- Start-up delay t_{s1} prior to first grid connection and after a short-term interruption, 30 s fixed
- Restart delay t_{s2} , 30 s fixed
- Powered by the measuring circuit
- True RMS measuring principle
- 2 c/o (SPDT) contacts
- 3 LEDs for the indication of operational states

Characteristics CM-UFD.M21

- Monitoring of three-phase mains for grid feeding
- Type-tested in accordance with VDE AR-N 4105
- Two-channel measuring circuit and two processors to ensure single-fault tolerance
- Over- and undervoltage, 10 minutes average value as well as over- and underfrequency monitoring
- Two-level threshold settings for over-/undervoltage/-frequency configurable according to 'BDEW guideline for generating plants connected to the medium voltage grid'
- Vector shift detection configurable
- Measured values, thresholds and settings shown on the display
- All threshold values adjustable as absolute values
- Default setting according to VDE AR-N 4105
- True RMS measuring principle
- 2 control inputs for feedback signal of subsequent section switch
- Monitoring of subsequent section switch configurable
- Tripping delay (0.05-130.00 s) for each single threshold adjustable
- Alarm memory for up to 99 entries (incl. cause of alarm, measured value, relative timestamp)
- Test function
- Simulation mode
- Code lock and mechanical sealing possible
- 5 digital outputs (transistor outputs) for signalling the cause of alarm to a superior control system
- 2 c/o (SPDT) contacts
- 105 mm (4.13 in) width
- LEDs for the indication of operational states
- Standby mode
- Optimized for use with generators
- Automatic restart after a failure in the feedback loop

Grid feeding monitoring relays - Voltage and frequency monitoring functions Operating controls - CM-UFD.Mxx

CM-UFD.M21

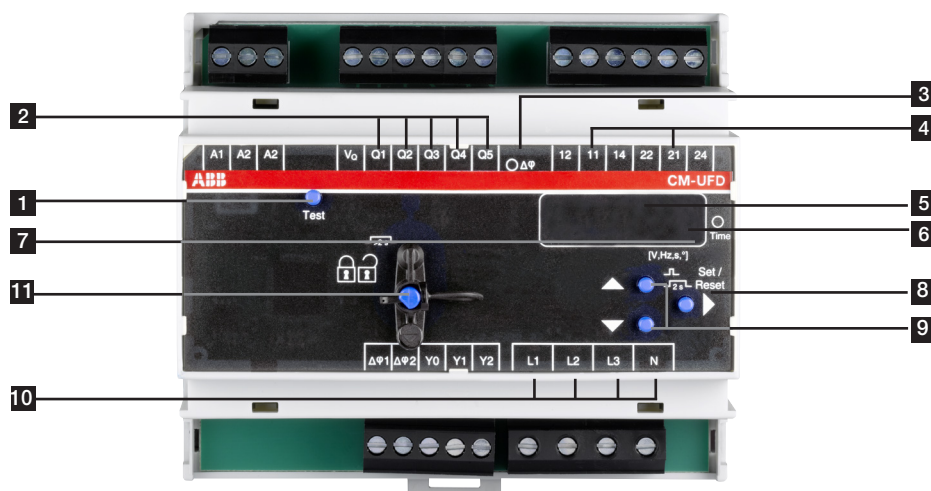

- 1** Button Test
- 2** Indication of operational states
Q1: red LED - overvoltage
Q2: red LED - undervoltage
Q3: red LED - overfrequency
Q4: red LED - underfrequency
Q5: red LED - error, if Pr-1 or Pr-2 activated ¹⁾
 $\Delta\varphi$: red LED - vector shift
- 3** $\Delta\varphi$: red LED - vector shift
- 4** 11: yellow LED - 1st c/o (SPDT) contact energized
21: yellow LED - 2nd c/o (SPDT) contact energized
- 5** Display (4-digits)
Voltage, 10 minutes average value, frequency or vector shift value, alarm and error messages
- 6** Indication of time
Time: yellow LED - a time delay is displayed
- 7** Indication of device mode
- 8** Button Set / Reset ►
- 9** Button Up / Down ▲ ▼
- 10** Indication of operational states
L1: yellow LED - kind of measured value
L2: yellow LED - kind of measured value
L3: yellow LED - kind of measured value
N: yellow LED - kind of measured value
- 11** Status indication of device locking and sealable lock button
Red LED - device is locked

¹⁾ if Pr-3 or Pr-4 activated, 2nd threshold referring to LED Q1-Q4.

CM-UFD.M22

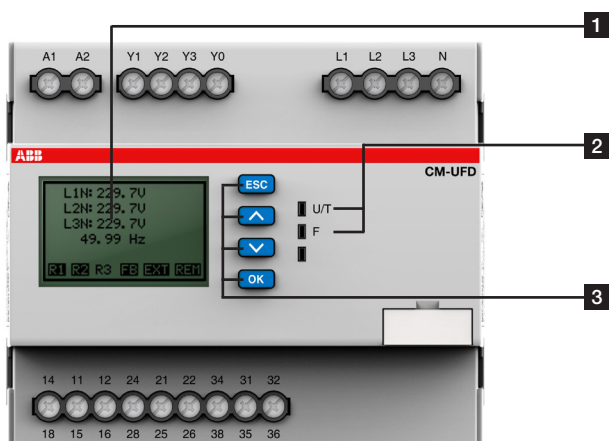

- 1** Display
R1 R2 R3 - relay status; in this case R3 is de-energized
FB - status feedback loop Y0-Y1; in this case FB is closed
EXT - status input external signal; in this case input is closed
REM - status remote trip input; in this case input is closed
- 2** Indication of operational states
U/T: green LED - supply voltage applied / flashing = timing active
F: red LED - failure
- 3** Keypad
ESC: escape / return to previous menu
▲: up / value increase
▼: down / value decrease
OK: enter / confirm selection

Grid feeding monitoring relays - Voltage and frequency monitoring functions Operating controls - CM-UFS.1

CM-UFS.1

2

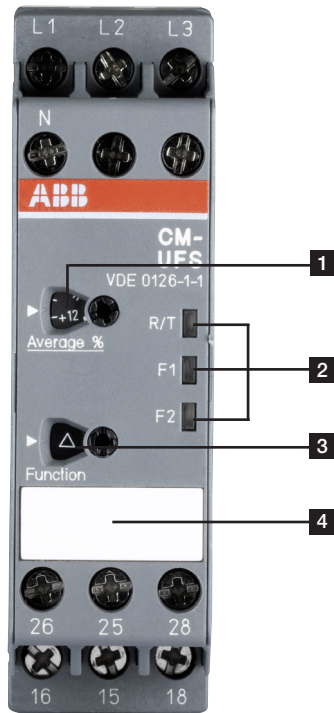

- 1** Adjustment of the threshold value for the 10 minutes average value
- 2** Indication of operational states
R/T: yellow LED - relay status, timing
F1: red LED - fault message
F2: red LED - fault message
- 3** Selection of neutral conductor, connected or not
- 4** Marker label

Grid feeding monitoring relays - Voltage and frequency monitoring functions Applications

Example of application - CM-UFD.M21

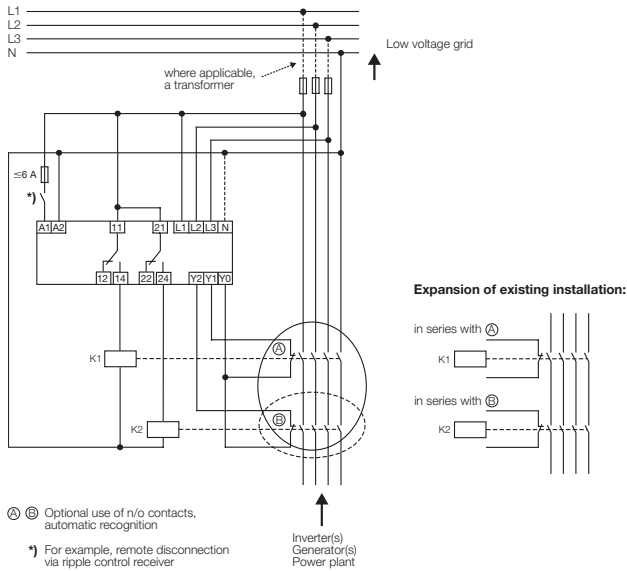

2CDC 252 013 F0212

Example of application - CM-UFS

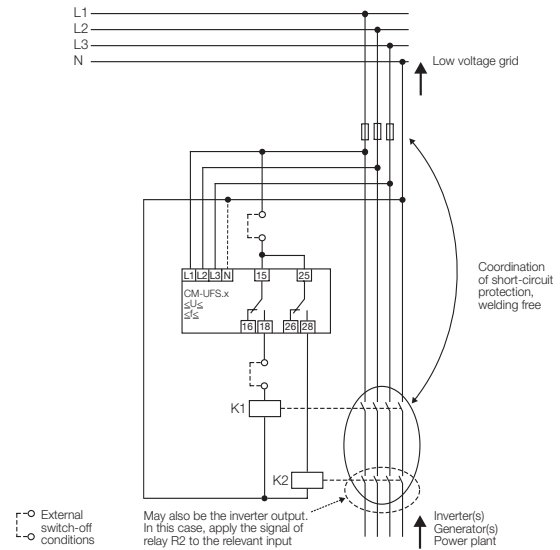

2CDC 252 022 F0209

Example of single-phase application CM-UFD.M22

Contactor as DDI ¹⁾

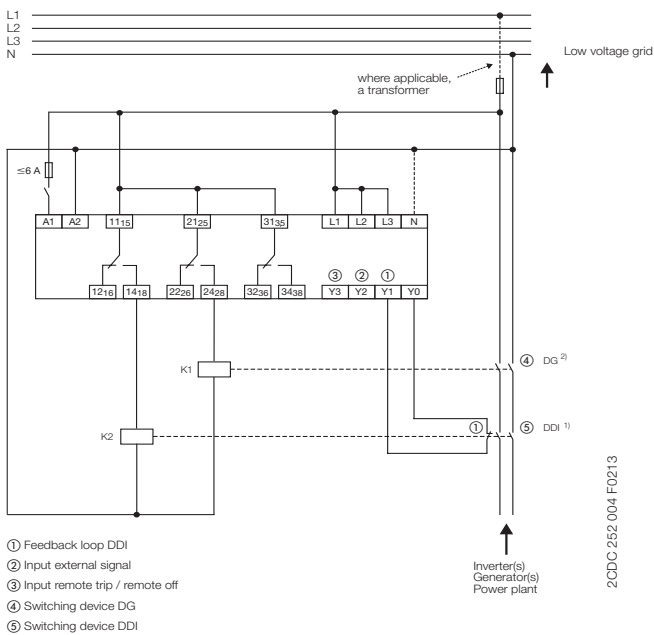

2CDC 252 004 F0213

Example of three-phase application CM-UFD.M22

Contactor as DDI ¹⁾, breaker as DG ²⁾

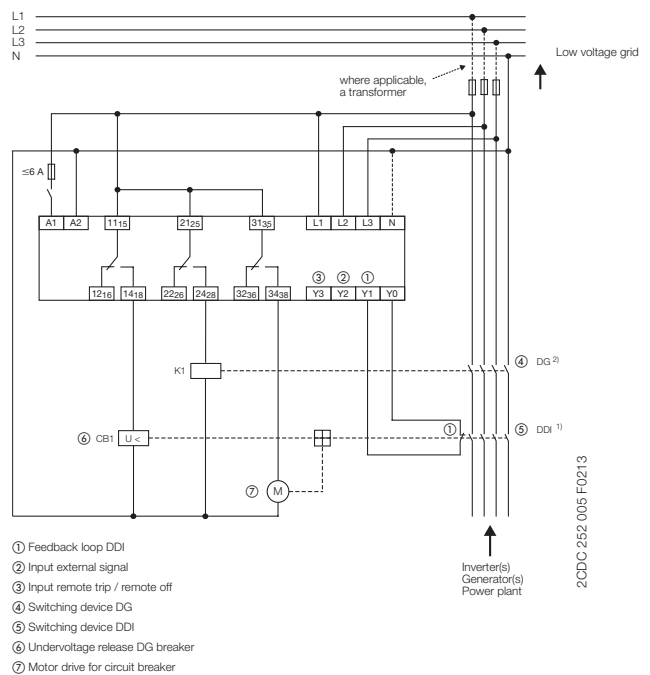

2CDC 252 005 F0213

¹⁾ DDI acc. to CEI 0-21

²⁾ DG acc. to CEI 0-21

Grid feeding monitoring relays - Voltage and frequency monitoring functions Ordering and selection

2



CM-UFD.M21

2CDC251 003 S0012



CM-UFD.M22

2CDC251 005 S0013



CM-UFS.1

2CDC251 014 S0009

Description

Only reliable and continuous monitoring of a three-phase network guarantees the trouble-free and economic operation of machines and installations.

Ordering details

Rated control supply voltage = measuring voltage	Type	Order code	Price 1 pce	Weight (1 pce) kg (lb)
24-240 V AC/DC	CM-UFD.M21	1SVR510730R0300		0.225 (0.496)
24-240 V AC/DC	CM-UFD.M22	1SVR560730R3400		0.283 (0.624)
3 x 400 V AC (L-L) / 230 V AC (L-N)	CM-UFS.1	1SVR630736R0300		0.14 (0.31)

Type	Order number
CM-UFD.M21	1SVR 510 730 R0300
CM-UFD.M22	1SVR 560 730 R3400
CM-UFS.1	1SVR 630 736 R0300

Rated control supply voltage U_s	CM-UFD.M21	CM-UFD.M22	CM-UFS.1
24-240 V AC/DC	■	■	
3 x 400 V AC (L-L) / 230 V AC (L-N)			■
Rated frequency			
DC and 50/60 Hz respectively	■		
50 Hz			■
DC or 50 Hz		■	
Suitable for monitoring			
Single-phase mains		■	
Three-phase mains	■	■	■
Monitoring function			
Over-/undervoltage	■	■	■
Over-/underfrequency	■	■	■
ROCOF (rate of change of frequency)		■	
10 minutes average value	■	■	■
Phase failure			■
Vector shift	■		
Thresholds	adj	adj	adj

Grid feeding monitoring relays - Voltage and frequency monitoring functions

Function diagrams - CM-UFS.1

Function of the yellow LED

The yellow LED is flashing during timing and turns steady as soon as the output relays are energized.

Phase failure monitoring

Applying control supply voltage begins the fixed start-up delay t_{S1} . When t_{S1} is complete and all phases are present with correct voltage and frequency, the output relays energize.

They de-energize instantaneously if a phase failure occurs. The fault is indicated by LEDs.

As soon as all 3 phases are present again, the output relays re-energize automatically after the fixed restart delay t_{S2} is complete.

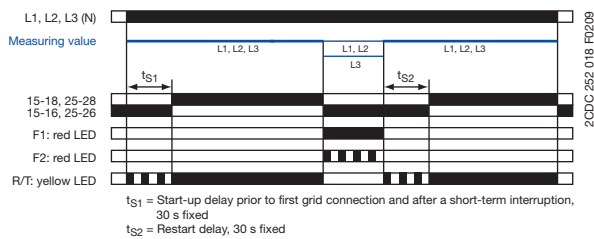

Over- and underfrequency monitoring

Applying control supply voltage begins the fixed start-up delay t_{S1} . When t_{S1} is complete and all phases are present with correct voltage and frequency, the output relays energize.

If the frequency to be monitored exceeds or falls below the fixed threshold value, the output relays deenergize instantaneously. The fault type is indicated by LEDs.

As soon as the frequency returns to the tolerance range, taking into account a fixed hysteresis, the output relays re-energize after the fixed restart delay t_{S2} is complete.

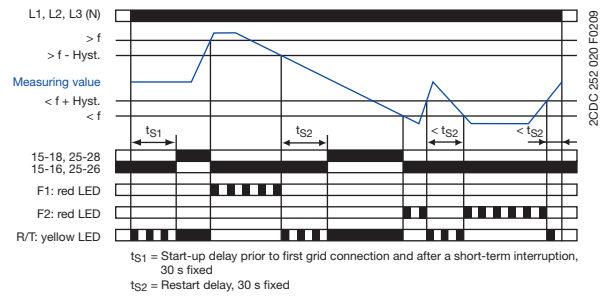

Over- and undervoltage monitoring

Applying control supply voltage begins the fixed start-up delay t_{S1} . When t_{S1} is complete and all phases are present with correct voltage and frequency, the output relays energize.

If the voltage to be monitored exceeds or falls below the fixed threshold value, the output relays de-energize instantaneously. The fault type is indicated by LEDs.

As soon as the voltage returns to the tolerance range, taking into account a fixed hysteresis of 5 %, the output relays re-energize after the fixed restart delay t_{S2} is complete.

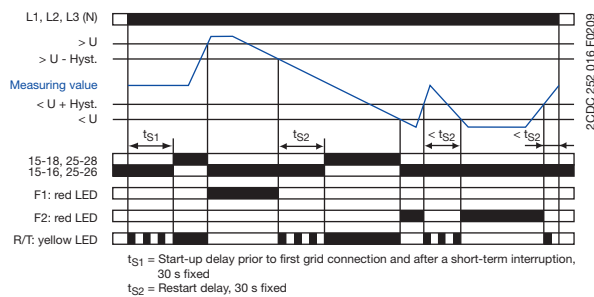

10 minutes average value monitoring

Applying control supply voltage begins the fixed start-up delay t_{S1} . When t_{S1} is complete and all phases are present with correct voltage and frequency, the output relays energize.

The voltages of the individual phases are measured over a period of 10 minutes and the average value is calculated. If the 10 minutes average value of a phase exceeds the set threshold value, the output relays de-energize instantaneously. The fault is indicated by LEDs.

As soon as the 10 minutes average value drops again below the set threshold value, the output relays reenergize instantaneously.

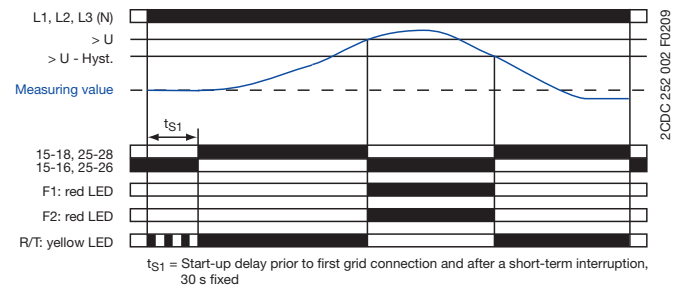

Grid feeding monitoring relays - Voltage and frequency monitoring functions Connection diagrams

2

Electrical connection - CM-UFS.1

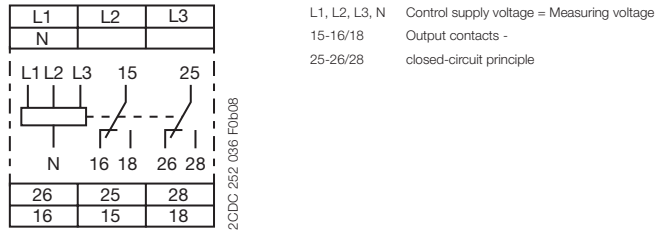

Electrical connection - CM-UFD.M21

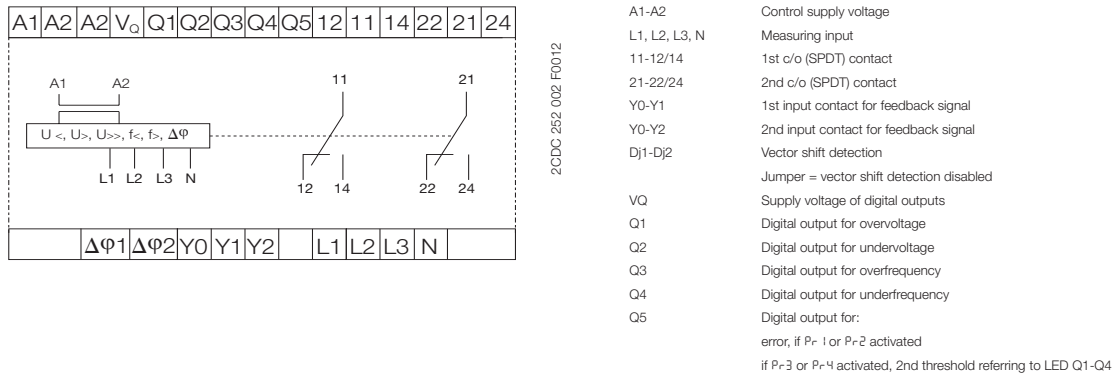

Electrical connection - CM-UFD.M22

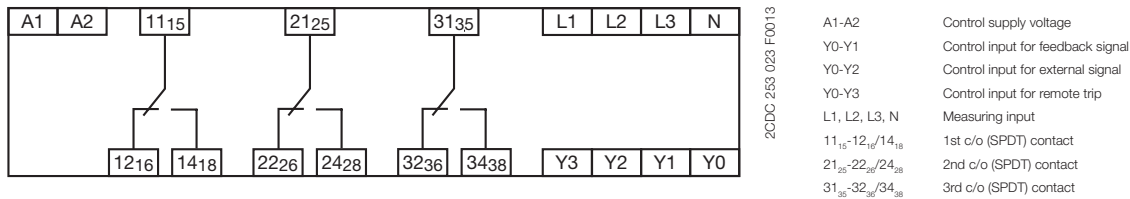

Grid feeding monitoring relays - Voltage and frequency monitoring functions

Technical data - CM-UFD.Mxx

Technical data

Data at $T_a = 25\text{ °C}$ and rated values, unless otherwise indicated

Type		CM-UFD.M21	CM-UFD.M22
Input circuit - Supply circuit		A1-A2	
Rated control supply voltage U_s		24-240 V AC/DC	
Rated control supply voltage U_s tolerance		-15...+20 %	-15...+10 %
Rated frequency		DC and 50/60 Hz respectively	DC or 50 Hz
Frequency range AC		40-70 Hz	40-60 Hz
Typical current / power consumption	24 V DC	92 mA / 2.2 W	64 mA / 1.5 W
	230 V AC	25 mA / 5.7 VA	6.4 mA / 1.5 VA
Power failure buffering time		5 ms	200 ms, according to LVFRT (Low Voltage Fault Ride Through)
Measuring circuit		L1, L2, L3 (N)	L1-N, L2-N, L3-N or L-L
Monitoring functions	over-/undervoltage $U^{--}, U^- / U_-, U_{--}$	yes, can be switched off	-
	over-/underfrequency $F^{--}, F^- / F_-, F_{--}$	yes, can be switched off	-
	10 minutes average value per phase U_{av}	yes, can be switched off	-
	vector shift α_{5r}	yes, can be switched off	-
	overvoltage av. (59 S1)	-	■
	overvoltage (59 S2)	-	■
	undervoltage (27 S1)	-	■
	undervoltage (27 S2)	-	■
	overfrequency (81 > S1)	-	■
	underfrequency (81 < S1)	-	■
	overfrequency (81 > S2)	-	■
	underfrequency (81 < S2)	-	■
	ROCOF	-	■ configurable
	Neutral	-	■ activated, if L-N
Measuring ranges	over-/undervoltage $U^{--}, U^- / U_-, U_{--}$	10-310 V AC (L1, L2, L3, N)	-
		15-530 V AC (L1, L2, L3)	-
	over-/underfrequency $F^{--}, F^- / F_-, F_{--}$	40-70 Hz	-
	vector shift α_{5r}	0...+45°	-
	voltage (4-wire system L1, L2, L3-N)	-	0-312 V AC
	(3-wire system L1, L2, L3)	-	0-540 V AC
	(2-wire system L-N)	-	0-312 V AC
	frequency	-	40-60 Hz
Threshold values	over-/undervoltage, 10 minutes average value $U^{--}, U^- / U_-, U_{--}, U_{\text{av}}$	15-300 V AC, adjustable in 0.1 V steps (< 100 V) / in 1 V steps (> 100 V) (L1, L2, L3, N)	-
		15-520 V AC, adjustable in 0.1 V steps (< 100 V) / in 1 V steps (> 100 V) (L1, L2, L3)	-
	over-/underfrequency $F^{--}, F^- / F_-, F_{--}$	45-65 Hz, adjustable in 0.01 Hz steps	-
	vector shift α_{5r}	2-20°, adjustable in 0.1° steps	-
	overvoltage med. (59 S1)	CM-UFD.M22: adjustable, 1.00-1.30 * U_s in 0.01 * U_s steps	-
	overvoltage (59 S2)	CM-UFD.M22: adjustable, 1.00-1.20 * U_s in 0.01 * U_s steps	-
	undervoltage (27 S1)	CM-UFD.M22: adjustable, 0.20-1.00 * U_s in 0.01 * U_s steps	-
	undervoltage (27 S2)	CM-UFD.M22: adjustable, 0.05-1.00 * U_s in 0.01 * U_s steps	-
	overfrequency (81 > S1)	CM-UFD.M22: adjustable, 50-54 Hz in 0.1 Hz steps	-
	underfrequency (81 < S1)	CM-UFD.M22: adjustable, 46-50 Hz in 0.1 Hz steps	-
	overfrequency (81 > S2)	CM-UFD.M22: adjustable, 50-54 Hz in 0.1 Hz steps	-
	underfrequency (81 < S2)	CM-UFD.M22: adjustable, 46-50 Hz in 0.1 Hz steps	-
	ROCOF	adjustable, 0.1-1 Hz/s, in 0.1 Hz/s steps	-
Hysteresis related to the threshold value	over-/undervoltage, 10 minutes average value $H^{--}, H^- / H_-, H_{--}, H_{\text{av}}$	1.0-99.9 V, adjustable in 0.1 V steps	-
	over-/underfrequency $H^{--}, H^- / H_-, H_{--}$	0.05-10.00 Hz, adjustable in 0.05 Hz steps	-
	Overvoltage	-	0.95-0.97 * U_s
	Undervoltage	-	1.03-1.05 * U_s
	Overfrequency	-	0.997-0.999 * f_n
	underfrequency	-	1.001-1.003 * f_n
Accuracy of measurements	voltage measurement L1, L2, L3, N	± 0.6 % of measured value	-
	voltage measurement L1, L2, L3	± 0.8 % of measured value	-
	frequency measurement	± 0.04 Hz ± 1 digit	-
	Voltage	-	≤ 2 %
	Frequency	-	± 20 mHz
	Delay times	-	≤ 5 % ± 20 ms
Display accuracy		> 100 V: ± 1 digit (1 V)	-
		< 100 V: ± 1 digit (0.1 V)	-
Rated frequency of measuring signal		50/60 Hz	50 Hz
Frequency range of the measuring signal		40-70 Hz	40-60 Hz

Grid feeding monitoring relays - Voltage and frequency monitoring functions

Technical data - CM-UFD.Mxx

2

Type		CM-UFD.M21	CM-UFD.M22
Measuring principle		True RMS	
	overvoltage U_{ov} , U_{ov}	< 65 ms	adjustable, 0.05-600 s in 0.05 steps, $\pm 3\% \pm 20$ ms
	undervoltage U_{uv} , U_{uv}	< 65 ms	
	overfrequency F_{of} , F_{of}	< 65 ms	
	underfrequency F_{uf} , F_{uf}	< 65 ms	
	10 minutes average value per phase U_{eff}	depending on the voltage jump	-
	vector shift α_{5F}	< 50 ms	-
Measuring cycle at 50 Hz	ROCOF	-	640 ms
Reaction time neutral interruption		-	< 150 ms
Accuracy within the rated control supply voltage tolerance		$\Delta U \leq 0.1\%$	-
Accuracy within the temperature range		$\Delta U \leq 0.15\% / ^\circ\text{C}$	$\Delta U \leq 0.02\% / ^\circ\text{C}$
Input circuit - Feedback circuits		Y10-Y11, Y20-Y21, Y30-Y31	Y0, Y1, Y2, Y3
Number		2	3
Kind of inputs	(Y0-Y1)	feedback contact of section switch 1	DDI feedback, trip and release monitoring times adjustable
	(Y0-Y2)	feedback contact of section switch 2	external signal
	(Y0-Y3)	-	remote trip
Electrical isolation	from supply voltage	yes	
	from the measuring circuit	no	
	from the relay outputs	yes	
Type of triggering		volt-free triggering	
Max. switching current in the control circuit		4 mA	6 mA
Max. cable length at the control input		5 m	10 m
No-load voltage at the control inputs		< 35 V DC	22-26 V DC (V0-V1, V2, V3)
Feedback time section switch		0.5-99 s, adjustable in steps of 0.1 s	20 ms
Control circuit vector shift detection (only CM-UFD.M21)		$\Delta\phi 1-\Delta\phi 2$	
Type of triggering		volt-free triggering	
Electrical isolation	from the supply voltage	yes	
	from the measuring circuit	no	
	from the relay outputs	yes	
	from the transistor outputs	yes	
Control input, control function		jumpered = vector shift detection de-activated open = vector shift detection activated (additional configuration in the software is necessary)	
Max. switching current in the control circuit		4 mA	
Max. cable length at the control input		5 m	
No-load voltage at the control inputs		< 35 V DC	
Timing circuits		CM-UFD.M21	CM-UFD.M22
Start-up delay (prior to first grid connection)		see 'adjustable OFF-delay' d_{OFF}	-
Start-up delay, R1 (prior to first grid connection or re-connection after interruption)		-	adjustable, 1.00-600.00 s in 0.05 s steps
Restart delay (after a short-term interruption <3 s)		5 s (fixed)	-
Restart delay, R1		-	adjustable, 0.05-600.00 s in 0.05 s steps
Start-up delay, R2 (prior to first grid connection or re-connection after interruption)		-	1 s, fixed
ON-delay, R3		-	adjustable, 0.00-10.00 s in 0.05 s steps
On-time, R3		-	adjustable, 0.05-10.00 s in 0.05 s steps
Trip window, feedback loop Y1		-	adjustable, 0.05-0.50 s in 0.05 s steps
Release window, feedback loop Y1		-	adjustable, 0.05-10.00 s in 0.05 s steps
Tripping delay		ON-and/or OFF-delay configurable	adjustable, 0.05-600.00 s in 0.05 s steps
ROCOF error time		-	adjustable, 0.05-600.00 s in 0.05 s steps
Adjustment range of the ON-delay	over-/undervoltage, over-/underfrequency d_{AL}	0.05-130.00 s, adjustable in 0.01 s steps	-
Tolerance of the ON-delay		0.1% \pm 5 ms	-
Adjustment range of the OFF-delay	over-/undervoltage, over-/underfrequency d_{OF}	0 (>200 ms)-999 s, adjustable in 1 s steps	-
	vector shift d_{OF}	3-240 s, adjustable in 1 s steps	-
Tolerance of the OFF-delay		0.1% \pm 105 ms	-
Delayed activation of the vector shift detection d_{EON}		2-20 s, adjustable in 1 s steps (Delay is effective just once after switching on or restart)	-
Accuracy within the rated control supply voltage tolerance		$\Delta t \leq 0.01\%$	$\Delta t \leq 0.5\% \pm 20$ ms
Accuracy within the temperature range		$\Delta t \leq 0.0001\% / ^\circ\text{C}$	$\Delta t \leq 1\% \pm 20$ ms

Grid feeding monitoring relays - Voltage and frequency monitoring functions

Technical data - CM-UFD.Mxx

Relay outputs			
Kind of outputs	11-12/14	Relay, 1st c/o (SPDT) contact	-
	21-22/24	Relay, 2nd c/o (SPDT) contact	-
		2 x 1 c/o (SPDT) contact	-
	11-12/14 (15-16/18)	-	relay, 1st c/o (SPDT) contact, trip delay for DDI
	21-22/24 (25-26/28)	-	relay, 2nd c/o (SPDT) contact, redundancy relay for DG
	31-32/34 (35-36/38)	-	relay, 3rd c/o (SPDT) contact, closing commander for breaker motor, also sync. with relay 1
Operating principle	11-12/14	closed-circuit principle	
	21-22/24	-	open- or closed-circuit principle configurable
	31-32/34	-	
Contact material		AgNi	AgNi allow, Cd free
Rated operational voltage U_g (IEC/EN 60947-1)		250 V AC	
Minimum switching voltage / minimum switching current		12 V / 10 mA	
Maximum switching voltage / maximum switching current		400 V AC / 6A	see load limit curves
Rated operational current I_g (IEC/EN 60947-5-1)	AC12 (resistive) 230 V	6 A	4 A
	AC15 (inductive) 230 V	1.5 A	3 A
	DC12 (resistive) 24 V	6 A	4 A
	DC13 (inductive) 24 V	2 A	2 A
			30 x 10 ⁸ switching cycles
Mechanical lifetime			
Electrical lifetime	at AC12, 230 V AC, 6 A	1 x 10 ⁸ switching cycles	50 x 10 ⁸ switching cycles
Maximum fuse rating to achieve short-circuit protection	n/c contact	6 A, operating class gG/gL	10 A fast tripping
	n/o contact	6 A, operating class gG/gL	10 A fast tripping
Conventional thermal current I_{th} (IEC/EN 60947-1)		6 A	5 A

Transistor outputs (only CM-UFD.M21)			
Number		5	
Rated operational voltage U_g		24 V DC	
Operational voltage range		4.5-27 V DC	
Residual ripple		5 %	
Current	state "0"	max. 0.1 mA / output	
	state "1"	max. 20 mA / output	
Electrical isolation	from the supply voltage	yes	
	from the measuring circuit	yes	
	from the relay outputs	yes	
	from the inputs of the feedback contacts	yes	
Maximum fuse rating to achieve short-circuit protection		100 mA fast-acting	

General data		CM-UFD.M21	CM-UFD.M22
MTBF		on request	
Repeat accuracy (constant parameters)		-	< ±0.5 %
Duty time		100%	
Dimensions (W x H x D)	product dimensions	105 x 90 x 69 mm (4.13 x 3.54 x 2.72 in)	108 x 90 x 67 mm (4.25 x 3.54 x 2.64 in)
	packaging dimensions	175 x 107 x 130 mm (6.89 x 4.21 x 5.12 in)	121 x 99 x 71 mm (4.76 x 3.90 x 2.80 in)
Weight	net weight	0.225 kg (0.496 lb)	0.283 kg (0.624 lb)
	gross weight	0.343 kg (0.756 lb)	0.334 kg (0.736 lb)
Mounting		DIN rail (IEC/EN 60715) TH 35-7.5 and TH 35-15, snap-on mounting without any tool	
Mounting position		any	
Minimum distance to other units	vertical	not necessary	
	horizontal	not necessary	
Material of housing			PA666FR
Degree of protection	housing / terminals	IP30 / IP20	IP20
Electrical connection		CM-UFD.M21	CM-UFD.M22
Wire size	fine-strand with wire end ferrule	1 x 0.5 - 2.5 mm ² (1 x 20 - 14 AWG)	1 x 0.25-4 mm ² (1 x 24-12 AWG), 2 x 0.25-0.75 mm ² (2 x 24-18 AWG)
		1 x 0.5 - 2.5 mm ² (1 x 20 - 14 AWG)	1 x 0.2-4 mm ² (1 x 24-12 AWG), 2 x 0.2-1.5 mm ² (2 x 24-16 AWG)
	rigid	1 x 0.5 - 4 mm ² (1 x 20 - 12 AWG)	1 x 0.2-0.6 mm ² (1 x 24-10 AWG), 2 x 0.2-1.5 mm ² (2 x 24-16 AWG)
Stripping length		7 mm (0.28 in)	8 mm (0.314 in)
Tightening torque		0.5 Nm (4.42 lb.in)	0.5-0.6 Nm (4.4-5.3 lb.in)

Grid feeding monitoring relays - Voltage and frequency monitoring functions

Technical data - CM-UFD.Mxx

2

Isolation data			
Rated insulation voltage U_i (IEC/EN 60947-1, IEC/EN 60664-1, VDE 0110-1)	supply / measuring / output circuits	300 V	600 V
	output 1 / output 2 / output 3	300 V	300 V
Rated impulse withstand voltage U_{imp} (IEC/EN 60947-1, IEC/EN 60664-1, VDE 0110-1)	supply / measuring / output circuits	4 kV	6 kV; 1.2/50 μ s
	output 1 / output 2 / output 3	4 kV	4 kV; 1.2/50 μ s
Basic insulation acc. rated control supply voltage (IEC/EN 60664-1, VDE 0110-1)	supply / measuring / output circuits	300 V	600 V
	output 1 / output 2 / output 3	300 V	300 V
Protective separation acc. rated voltage (VDE 0106 part 101 and 101/A1; IEC/EN 61440)	supply / measuring / output circuits	-	250 V
	output 1 / output 2 / output 3	-	250 V
Test voltage, routine test (IEC/EN 60255-5, IEC/EN 61010-1)	supply / measuring / output circuits	3.82 kV DC	2.2 kV, 50 Hz, 1s
	output 1 / output 2 / output 3	3.82 kV DC	2.2 kV, 50 Hz, 1s
Test voltage, type test (CEI 0-21)	supply / measuring / output circuits	-	5 kV, 50 Hz, 1s
	output 1 / output 2 / output 3	-	4 kV, 50 Hz, 1s
Pollution degree (IEC/EN 60664-1, VDE 0110-1)		2	3
Overvoltage category (IEC/EN 60664-1, VDE 0110-1)		II	IV
Environmental data			
Ambient temperature ranges	operation	-20...+55 °C	-20...+60 °C
	storage	-20...+70 °C	-20...+80 °C
	transport	-20...+70 °C	-20...+80 °C
Damp heat, cyclic (IEC 60068-2-30)		55 °C, 6 cycles	6 x 24 h cycle, 55 °C, 95 % RH
Climatic category (EN 50178)		3K3	3K5 (w/o condensation, w/o icing)
Vibration, sinusoidal (IEC/EN 60255-21-1)		Class 1	Class 2
Shock (IEC/EN 60255-21-2)		Class 1	Class 2
Standards / Directives			
Product standard		IEC/EN 60255	IEC/EN 60255-1
Application standards		VDE-AR-N 4105, BDEW	CEI 0-21: 2012-06 + CEI 0-12; V1: 2012-12 + A70 Terna
Low Voltage Directive		2006/95/EC	
EMC Directive		2004/108/EC	
RoHS Directive		2002/95/EC	2011/65/EC
Electromagnetic compatibility			
Interference immunity to		IEC/EN 61000-6-1, IEC/EN 61000-6-2. CM-UFD.M22: CEI 0-21 Tab.11	
electrostatic discharge radiated, radio-frequency, electromagnetic field	IEC/EN 61000-4-2 IEC/EN 61000-4-3	Level 3, 6 kV / 8 kV CM-UFD.M22: Level 3, 10 V/m CM-UFD.M21: Level 3, 10 V/m (80-1000 MHz) Level 2, 3 V/m (1400-2000 MHz) Level 1, 1 V/m (2000-2700 MHz)	
electrical fast transient / burst surge	IEC/EN 61000-4-4 IEC/EN 61000-4-5	Level 4, 4 kV / 5 kHz Level 3, 1 kV L-L, 2kV L-earth	Level 3, 2 kV / 5 kHz Level 3, installation class 3, supply and measuring input 1 kV L-L, 2 kV L-earth
conducted disturbances, induced by radio-frequency fields	IEC/EN 61000-4-6	Level 3, 10 V	
Interference emission		IEC/EN 61000-6-3, IEC/EN 61000-6-4	
high-frequency radiated	IEC/CISPR 22, EN 55022	Class B	
high-frequency conducted	IEC/CISPR 22, EN 55022	Class B	

Grid feeding monitoring relays - Voltage and frequency monitoring functions

Technical data - CM-UFS.1

2

Type	CM-UFS.1	
Input circuit - Supply circuit	L1, L2, L3	L-N
Rated control supply voltage U_s = measuring voltage	3 x 400 V AC	3 x 230 V AC
Rated control supply voltage tolerance U_s	-20...+20 %	
Control supply voltage range	3 x 300-500 V AC	3 x 180-280 V AC
Rated frequency	50 Hz	
Frequency range	45-55 Hz	
Typical current / power consumption	23 mA / 16 VA	
Power failure buffering time	min. 20 ms	
Input circuit - Measuring circuit		
Monitoring functions	Phase failure	■
	Over-/ undervoltage	■
	Over-/ underfrequency	■
	10 minutes average value	■
Measuring range	Voltage range	3 x 320-460 V AC
	Frequency range	45-55 Hz
Thresholds	Overvoltage	115 % of U_s , fixed
	Undervoltage	80 % of U_s , fixed
	Overfrequency	50.2 Hz fixed
	Underfrequency	47.5 Hz fixed
	10 minutes average value	110-115% of U_s , adjustable
Hysteresis related to the threshold value	Over-/ undervoltage	5 % fixed
	Over-/ underfrequency	20 mHz fixed
Rated frequency of the measuring signal	50 Hz	
Frequency range of the measuring signal	45-55 Hz	
Maximum measuring cycle time	50 ms	
Maximum reaction time (time between fault detection and change of switching status of the relay)	Over-/ undervoltage	< 120 ms
	Over-/ underfrequency	< 100 ms
	10 minutes average value	without delay
Accuracy within the rated control supply voltage tolerance	$\Delta U \leq 0.5 \%$	
Accuracy within the temperature range	$\Delta U \leq 0.06 \%$ / °C	
Measuring method	True RMS	
Timing circuit		
Start-up delay t_{s1} prior to grid connection after a short interruption	30 s fixed	
Restart delay t_{s2}	30 s fixed	
Accuracy within the rated control supply voltage tolerance	$\Delta t \leq 0.5 \%$	
Accuracy within the temperature range	$\Delta t \leq 0.06 \%$ / °C	
Indication of operational states	1 yellow LED, 2 red LEDs Details see operation mode and function description/diagrams	
Output circuits	15-16/18, 25-26/28	
Kind of output	Relay, 1 x 2 c/o (SPDT) contacts	
Operation principle	closed-circuit principle ¹⁾	
Contact material	AgNi alloy, Cd free	
Rated operational voltage U (IEC/EN 60947-1)	250 V	
Minimum switching voltage / switching current	24 V / 10 mA	
Maximum switching voltage / switching current	see load limit curve	
Rated operational current I (IEC/EN 60947-5-1)	AC12 (resistive) 230 V	4 A
	AC15 (inductive) 230 V	3 A
	DC12 (resistive) 24 V	4 A
	DC13 (inductive) 24 V	2 A
Mechanical lifetime	30 x 10 ⁶ switching cycles	
Electrical lifetime (AC12, 230 V, 4 A)	0.1 x 10 ⁶ switching cycles	
Max. fuse rating to achieve short-circuit protection	n/c contact	6 A fast-acting
	n/o contact	10 A fast-acting

¹⁾ Closed-circuit principle: Output relay(s) de-energize(s) if measured value exceeds or falls below the adjusted threshold value

Grid feeding monitoring relays - Voltage and frequency monitoring functions

Technical data - CM-UFS.1

Type		CM-UFS.1
General data		
MTBF		on request
Duty time		100%
Repeat accuracy (constant parameters)		< ± 50
Dimensions (W x H x D)	product dimensions	22.5 x 78 x 100 mm (0.89 x 3.07 x 3.94 in)
Weight	gross weight	0.140 kg (0.31 lb)
Mounting		DIN rail (IEC/EN 60715), snap-on mounting without any tool
Mounting position		any
Minimum distance to other units	vertical / horizontal	not necessary / not necessary
Degree of protection	housing / terminals	IP50 / IP20
Electrical connection		
Wire size	fine-strand with(out) wire end ferrule	2 x 0.75 - 2.5 mm ² (2 x 18-14 AWG)
	rigid	2 x 0.5 - 4 mm ² (2 x 20-12 AWG)
Stripping length		7 mm (0.28 in)
Tightening torque		0.6-0.8 Nm (5.31-7.08 lb.in)
Environmental data		
Ambient temperature range	operation / storage	-25...+60 °C / -40...+85 °C
Damp heat, cyclic (IEC/EN 60068-2-30)		2 x 12 h cycle, 55 °C, 95 % RH
Climatic category (IEC/EN 60721-3-1)		3K3
Vibration (sinusoidal) (IEC/EN 60255-21-1)		Class 2
Shock (IEC/EN 60255-21-2)		Class 2
Isolation data		
Rated impulse withstand voltage U _i	input circuit / output circuit	600 V
	output circuit 1 / 2	300 V
Rated impulse withstand voltage U _{imp} (VDE 0110, IEC/EN 60664)	input circuit	6 kV; 1.2/50 µs
	output circuit	4 kV; 1.2/50 µs
Test voltage between all isolated circuits (routine test)		2.5 kV, 50 Hz, 1 s
Basic insulation	input circuit / output circuit	600 V
Protective separation (VDE 0160 Part 101 and 101/A, IEC/EN 61140)	input circuit / output circuit	yes
Pollution degree (VDE 0110, IEC/EN 60664)		3
Overvoltage category (VDE 0110, IEC 60664)		III
Standards		
Product standard	IEC/EN 60255-6, DIN V VDE V 0126-1-1: February 2006	IEC/EN 60255-6, Guideline for connections to ENEL distribution network Ed. 2.1, January 2011
Further standards	EN 50178, EN 61727	
Low Voltage Directive	2006/95/EC	
EMV-Directive	2004/108/EC	
RoHS-Directive	2002/95/EC	
Electromagnetic compatibility		
Interference immunity to		IEC/EN 61000-6-1, IEC/EN 61000-6-2
electrostatic discharge	IEC/EN 61000-4-2	Level 3 (6 kV / 8 kV)
radiated, radio-frequency, electromagnetic field	IEC/EN 61000-4-3	Level 3 (10 V/m)
electrical fast transient / burst	IEC/EN 61000-4-4	Level 3 (2 kV / 2 kHz)
surge	IEC/EN 61000-4-5	Level 4 (2 kV L-L, L-N)
conducted disturbances, induced by radio-frequency fields	IEC/EN 61000-4-6	Level 3 (10 V)
harmonics and interharmonics	IEC/EN 61000-4-13	Class 3
Interference emission		IEC/EN 61000-6-3, IEC/EN 61000-6-4
high-frequency radiated	IEC/CISPR 22, EN 50022	Class B
high-frequency conducted	IEC/CISPR 22, EN 50022	Class B

Insulation monitoring relays for unearthed supply systems

Product group picture

2

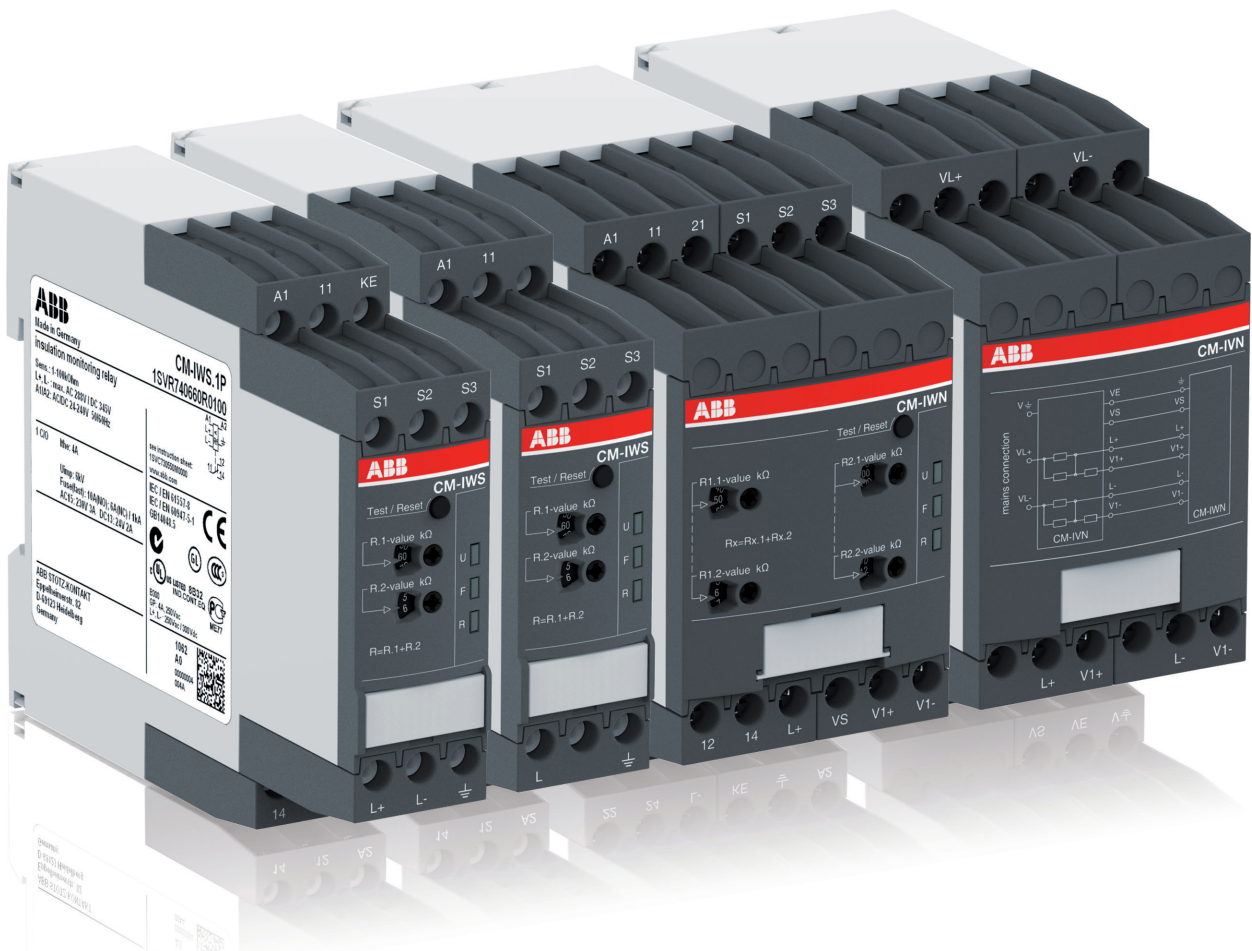

Insulation monitoring relays for unearthed supply systems

Table of contents

Insulation monitoring relays for unearthed supply systems	
Product group picture	63
Table of contents	64
Benefits and advantages	65
Benefits and advantages, applications	66
Operating controls	67
Selection table	68
Insulation monitoring in IT systems	69
Ordering details	70
Operating state indication, Connection diagrams, DIP switches	71
Connection diagrams, DIP switches	72
Technical data	73
Technical data CM-IVN	76

Insulation monitoring relays for unearthed supply systems

Benefits and advantages

2

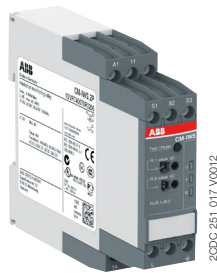

CM-IWS.2



CM-IWS.1

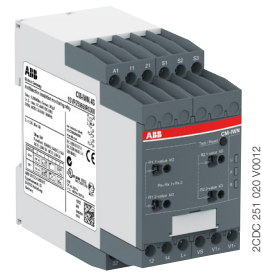

CM-IWN.1

Insulation monitoring relays for unearthed pure AC systems: Characteristics

- For monitoring the insulation resistance of unearthed IT systems: up to $U_n = 400$ V AC
- According to IEC/EN 61227-8 "Electrical safety in low voltage distribution systems up to 1000 V AC and 1500 V DC – Equipment for testing, measuring or monitoring of protective measures – Part 8: Insulation monitoring devices for IT systems"
- Rated control supply voltage 24–240 V AC/DC
- Superimposed DC signal
- One measuring range 1–100 k Ω
- Precise adjustment of the threshold value in 1 k Ω steps
- Interrupted wire detection
- Fault storage/latching configurable by control input
- 1 c/o (SPDT) contact, closed-circuit principle
- 22.5 mm [0.89 in] width
- 3 LEDs for status indication

Insulation monitoring relays for unearthed AC, DC or mixed AC/DC systems: Characteristics

- For monitoring the insulation resistance of unearthed IT systems up to $U_n = 250$ V AC and 300 V DC or $U_n = 400$ V AC and 600 V DC
- According to IEC/EN 61227-8 "Electrical safety in low voltage distribution systems up to 1000 V AC and 1500 V DC – Equipment for testing, measuring or monitoring of protective measures – Part 8: Insulation monitoring devices for IT systems"¹⁾
- CM-IWN.4,5,6: Specifically for applications with high system leakage capacitances, for example in photovoltaic environments
- Rated control supply voltage 24–240 V AC/DC
- Prognostic measuring principle with superimposed square wave signal
- 1 or 2 measuring ranges (1–100 k Ω or 1–100 k Ω + 2–200 k Ω)
- 1 or 2 (configurable) c/o contacts¹⁾
- Precise adjustment of the measuring value in 1 or 2 k Ω steps
- (non-volatile) fault storage, configurable latching, interrupted wire protection, open- or closed-circuit principle selectable¹⁾
- 22.5 or 45 mm width
- 3 LEDs for status indication

¹⁾ depending on devices

Additional characteristics for CM-IWN.1,4,5,6:

- One (1 x 2 c/o) or two (2 x 1 c/o) threshold values $R_{an1}/R1$ ¹⁾ (final switch-off) and $R_{an2}/R2$ ²⁾ (prewarning) configurable³⁾
- Precise adjustment of the threshold values in 1 k Ω steps (R1) and 2 k Ω steps (R2)
- Interrupted wire detection configurable
- Non-volatile fault storage configurable
- Open- or closed-circuit principle configurable

¹⁾ CM-IWN.6 does not meet the requirements of IEC/EN 61557-8 regarding the response time t_{an} .

²⁾ term acc. to IEC/EN 61557-8

³⁾ R2 only active with 2 x 1 c/o configuration

Insulation monitoring relays for unearthed supply systems

Benefits and advantages, Applications

Application / monitoring function CM-IWx

The CM-IWx serve to monitor insulation resistance in accordance with IEC 61557-8 in unearthed IT AC systems, IT AC systems with galvanically connected DC circuits, or unearthed IT DC systems. The insulation resistance between system lines and system earth is measured. If this falls below the adjustable threshold values, the output relay(s) energize or de-energize. The CM-IWS.x can monitor control circuits (single-phase) and main circuits (3-phase). Supply systems with voltages $U_n = 0-400$ V AC (45-65 Hz), $U_n = 0-250$ V AC (15-400 Hz) or $0-300$ V DC can be directly connected. For systems with voltages above 400 V AC the insulation monitoring relay with or without the coupling unit CM-IVN can be used.

Application / monitoring function CM-IWN.x

The CM-IWN.x serves to monitor insulation resistance in accordance with IEC 61557-8 in unearthed IT AC systems, IT AC systems with galvanically connected DC circuits, or unearthed IT DC systems. The insulation resistance between system lines and system earth is measured. If this falls below the adjustable threshold values, the output relays switch into the fault state. The device can monitor control circuits (single-phase) and main circuits (3-phase). Supply systems with voltages $U_n = 0-400$ V AC (15-400 Hz) or $0-600$ V DC can be directly connected to the measuring inputs and their insulation resistance being monitored. For systems with voltages above 400 V AC and 600 V DC the coupling unit CM-IVN can be used for the expansion of the CM-IWN.x voltage range.

Expansion of assortment for the requirements of decentral electrical energy sources

ABB's insulation monitoring relays from the CM-IWN range provide higher system leakage capacitances which are necessary especially for solar applications. This expanded product range covers the requirements of decentral electrical sources (e.g. photovoltaic systems). The range of system leakage capacitances is 20 - 2000 μ F.

Application / monitoring function CM-IVN

The coupling unit CM-IVN is designed to extend the nominal voltage range of the insulation monitoring relay CM-IWN.1 up to 690 V AC and 1000 V DC. The coupling unit can be connected to the system to be monitored by means of the terminals VL+ and VL-. The terminal Vw has to be connected to the earth potential. The terminals L+, V1+, L-, V1-, VS and VE have to be connected to the CM-IWN.1 as shown in the connection diagrams below. Supply systems with voltages $U_n = 0-690$ V AC (15-400 Hz) or $0-1000$ V DC can be connected.

Measuring principle CM-IWS.2

A superimposed DC measuring signal is used for measurement. From the superimposed DC measuring voltage and its resultant current the value of the insulation resistance of the system to be monitored is calculated.

Measuring principle CM-IWN.x, CM-IWS.1

A pulsating measuring signal is fed into the system to be monitored and the insulation resistance is calculated. This pulsating measuring signal alters its form depending on the insulation resistance and system leakage capacitance. From this altered form the change in the insulation resistance is forecast. When the forecast insulation resistance corresponds to the insulation resistance calculated in the next measurement cycle and is smaller than the set threshold value, the output relay de-energizes. This measuring principle is also suitable for the detection of symmetrical insulation faults.



Insulation monitoring relays for unearthed supply systems

Operating controls

2

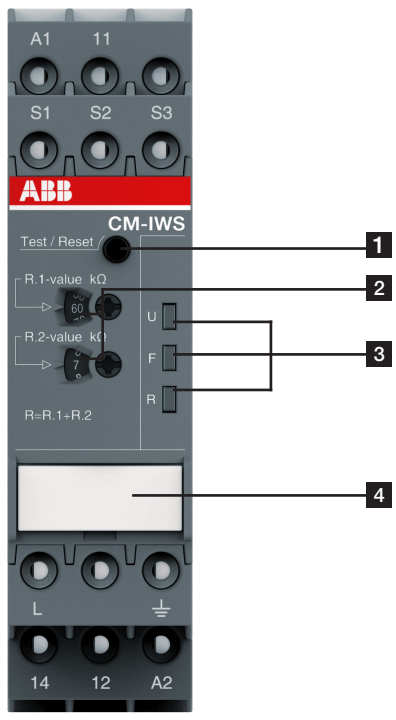

- 1 Test and reset button**
- 2 Configuration and setting**
Front-face rotary switches for threshold value adjustment:
R.1 for R1 tens figures:
0, 10, 20, 30, 40, 50, 60, 70, 80, 90 kΩ in ten kΩ steps
R.2 for R1 units figures:
1, 2, 3, 4, 5, 6, 7, 8, 9, 10 kΩ in one kΩ steps
- 3 Indication of operational states**
U: green LED - control supply voltage
F: red LED - fault message
R: yellow LED - relay status
- 4 Marker label for devices without DIP switches**

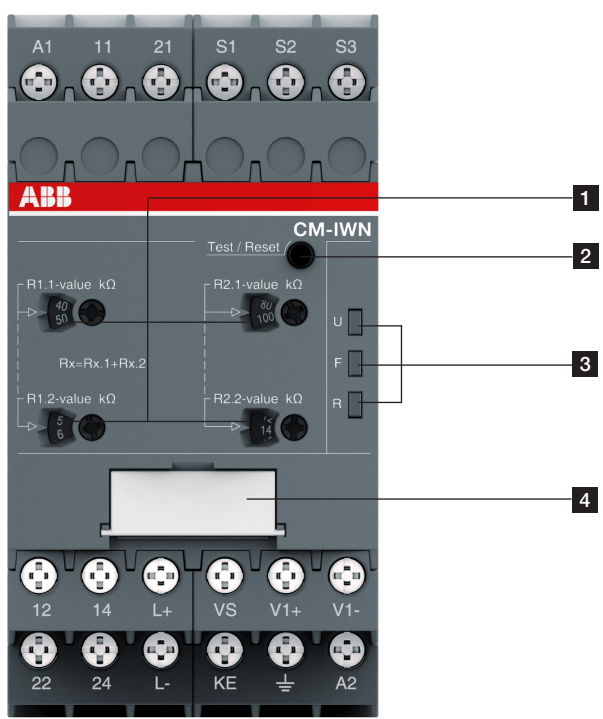

- 1 Front-face rotary switches to adjust the threshold value:**
R1.1 for R1 tens figure:
0, 10, 20, 30, 40, 50, 60, 70, 80, 90 kΩ in ten kΩ steps
R1.2 for R1 units figure:
1, 2, 3, 4, 5, 6, 7, 8, 9, 10 kΩ in one kΩ steps
R2.1 for R2 tens figure:
0, 20, 40, 60, 80, 100, 120, 140, 160, 180 kΩ in twenty kΩ steps
R2.2 for R2 units figure:
2, 4, 6, 8, 10, 12, 14, 16, 18, 20 kΩ in two kΩ steps
- 2 Test and reset button**
- 3 Indication of operational states**
U: green LED – control supply voltage
F1: red LED – fault message
F2: yellow LED – relay status
- 4 DIP switches (see DIP switch functions)**

Insulation monitoring relays for unearthed supply systems

Insulation monitoring in IT systems

In electricity supply systems, an earthing system defines the electrical potential of the conductors relative to that of the earth's conductive surface. The choice of earthing system has implications for the safety and electromagnetic compatibility of the power supply. Note that regulations for earthing (grounding) systems vary considerably among different countries.

The international standard IEC 60364 distinguishes three families of earthing arrangements, using the two-letter codes TN, TT and IT.

The first letter indicates the connection between earth and the power-supply equipment (generator or transformer):

T: direct connection of a point with earth (Latin: terra)

I: no point is connected with earth (insulation),
except perhaps via a high impedance

The second letter indicates the connection between earth and the electrical device being supplied:

T: direct connection of a point with earth

N: direct connection to neutral at the origin of installation,
which is connected to the earth

IT supply systems

The IT system is supplied either by an isolation transformer or a voltage source, such as battery or a generator.

In this system no active conductor is directly connected to earth potential. The advantage of this is that only a small fault current can flow in case of an insulation fault. This current is essentially caused by the leakage capacitance of the system.

The fuse of the system or MCB does not respond, thus maintaining the voltage supply and therefore operation even in case of a phase-to-earth fault.

The high reliability of an IT system is guaranteed thanks to continuous insulation monitoring.

The insulation monitoring device recognizes insulation faults as they develop, and immediately reports that the value has fallen below the minimum. This prevents operational interruptions caused by a second more severe insulation fault.

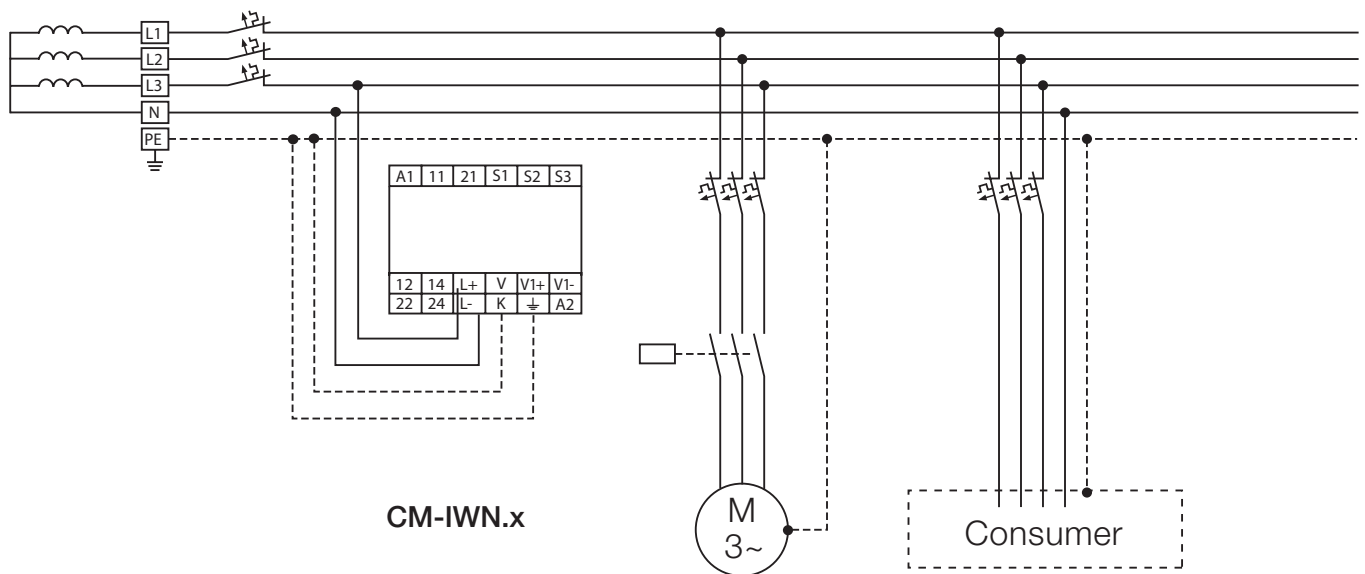

Insulation monitoring relays for unearthed supply systems

Selection table

	Type	Order number																			
	CM-IWS.2S	1SVR 730 670 R0200																			
	CM-IWS.2P	1SVR 740 670 R0200																			
	CM-IWS.1S	1SVR 730 660 R0100																			
	CM-IWS.1P	1SVR 740 660 R0100																			
	CM-IVN.1S	1SVR 750 660 R0200																			
	CM-IVN.1P	1SVR 760 660 R0200																			
	CM-IVN.4S	1SVR 750 660 R0300																			
	CM-IVN.4P	1SVR 760 660 R0300																			
	CM-IVN.5S	1SVR 750 660 R0400																			
	CM-IVN.5P	1SVR 760 660 R0400																			
	CM-IVN.6S	1SVR 750 660 R0500																			
	CM-IVN.6P	1SVR 760 660 R0500																			
Rated control supply voltage U_s																					
24 - 240 VAC/DC			■	■	■	■	■	■	■	■	■	■	■	■	■	■	■	■	■	■	■
Measuring voltages																					
250 V AC (L-PE)					■	■															
400 V AC (L-PE)			■	■			■	■	■	■	■	■	■	■	■	■	■	■	■	■	■
690 V AC (L-PE)							■ ¹⁾	■ ¹⁾	■ ¹⁾	■ ¹⁾	■ ¹⁾	■ ¹⁾	■ ¹⁾	■ ¹⁾	■ ¹⁾	■ ¹⁾	■ ¹⁾	■ ¹⁾	■ ¹⁾	■ ¹⁾	■ ¹⁾
300 V DC (L-PE)					■	■															
600 V DC (L-PE)							■	■	■	■	■	■	■	■	■	■	■	■	■	■	■
1000 V DC (L-PE)							■ ¹⁾	■ ¹⁾	■ ¹⁾	■ ¹⁾	■ ¹⁾	■ ¹⁾	■ ¹⁾	■ ¹⁾	■ ¹⁾	■ ¹⁾	■ ¹⁾	■ ¹⁾	■ ¹⁾	■ ¹⁾	■ ¹⁾
Measuring range																					
1 - 100 k Ω			■	■	■	■	■	■	■	■	■	■	■	■	■	■	■	■	■	■	■
2 - 200 k Ω							■	■	■	■	■	■	■	■	■	■	■	■	■	■	■
System leakage capacitance, max.																					
10 μ F			■	■	■	■															
20 μ F							■	■													
500 μ F									■	■											
1000 μ F											■	■									
2000 μ F													■	■							
Output																					
1 c/o			■	■	■	■															
1 x 2 c/o or 2 x 1 c/o							■	■	■	■	■	■	■	■	■	■	■	■	■	■	■
Operating principle																					
Open-circuit principle			■	■	■	■															
Open- or closed-circuit principle adjustable							■	■	■	■	■	■	■	■	■	■	■	■	■	■	■
Test																					
Front face button or control input			■	■	■	■	■	■	■	■	■	■	■	■	■	■	■	■	■	■	■
Reset																					
Front-face button or control input			■	■	■	■	■	■	■	■	■	■	■	■	■	■	■	■	■	■	■
Fault storage / latching configurable			■	■	■	■	■	■	■	■	■	■	■	■	■	■	■	■	■	■	■
Non volatile storage configurable			■	■	■	■	■	■	■	■	■	■	■	■	■	■	■	■	■	■	■
Interrupted wire detection							■	■	■	■	■	■	■	■	■	■	■	■	■	■	■
Threshold values configurable			1	1	1	1	2	2	2	2	2	2	2	2	2	2	2	2	2	2	2
1) With coupling unit CM-IVN		screw version		CM-IVN.S: 1SVR750669R9400																	
		push-in version		CM-IVN.P: 1SVR760669R9400																	

Insulation monitoring relays for unearthed supply systems

Ordering details



CM-IWS.2

Description

The high reliability of an IT system is guaranteed thanks to continuous insulation monitoring. An insulation monitoring device recognizes insulation faults as they develop, and immediately reports that the value has fallen below the minimum. This prevents operational interruption caused by a second, more severe insulation fault.

ABB developed a totally new range of insulation monitors for AC, DC or mixed AC/DC IT Systems up to 690 V AC or 1000 V DC. With only 4 devices most standard applications can be served. Additionally a version for solar applications with increased earth leakage capacitance has been added.

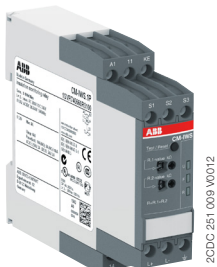

CM-IWS.1



CM-IWN.1

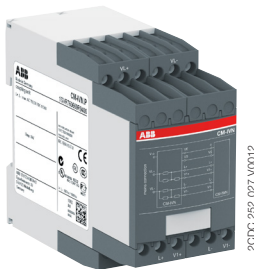

CM-IVN

Ordering details

Rated control supply voltage = measuring voltage	Nominal voltage U_n of the distribution system to be monitored	System leakage capacitance, max.	Adjustment range of the specified response value R_{an} (threshold)	Type	Order code	Price	Weight (1 pce)
						1 pce	kg (lb)
24-240 V AC/DC	0-250 V AC / 0-300 V DC	10 μ F	1-100 k Ω	CM-IWS.1S	1SVR730660R0100		0.148 (0.326)
				CM-IWS.1P	1SVR740660R0100		0.137 (0.302)
24-240 V AC/DC	0-400 V AC	10 μ F	1-100 k Ω	CM-IWS.2S	1SVR730670R0200		0.141 (0.311)
				CM-IWS.2P	1SVR740670R0200		0.130 (0.287)
24-240 V AC/DC	0-400 V AC / 0-600 V DC	20 μ F		CM-IWN.1S	1SVR750660R0200		0.241 (0.531)
				CM-IWN.1P	1SVR760660R0200		0.217 (0.478)
24-240 V AC/DC	0-400 V AC / 0-600 V DC	500 μ F	1-100 k Ω 2-200 k Ω (activated / de-activated by DIP-switch)	CM-IWN.4S	1SVR750660R0300		0.241 (0.531)
				CM-IWN.4P	1SVR760660R0300		0.217 (0.478)
24-240 V AC/DC	0-400 V AC / 0-600 V DC	1000 μ F		CM-IWN.5S	1SVR750660R0400		0.241 (0.531)
				CM-IWN.5P	1SVR760660R0400		0.217 (0.478)
24-240 V AC/DC	0-400 V AC / 0-600 V DC	2000 μ F		CM-IWN.6S	1SVR760660R0500		0.241 (0.531)
				CM-IWN.6P	1SVR760660R0500		0.217 (0.478)

Ordering details - Coupling unit

Rated control supply voltage = measuring voltage	Nominal voltage U_n of the distribution system to be monitored	Type	Order code	Price	Weight (1 pce)
				1 pce	kg (lb)
Passive device, no control supply voltage needed	0-690 V AC / 0-1000 V DC	CM-IVN.S	1SVR750669R9400		0.179 (0.395)
		CM-IVN.P	1SVR760669R9400		0.165 (0.364)

S: screw connection
P: push-in / easy connect

Insulation monitoring relays for unearthed supply systems

Operating state indication, Connection diagrams, DIP switches

LEDs, status information and fault messages CM-IWN.x

Operational state	LED U (green)	LED F (red)	LED R (yellow)
Start-up		OFF	OFF
No fault		OFF	¹⁾
Prewarning			
Insulation fault (below threshold value)			¹⁾
KE/⊥ wire interruption			¹⁾
L+/L- wire interruption during system start-up / test function			¹⁾
System leakage capacitance too high / invalid measurement result			¹⁾
Internal system fault	¹⁾		¹⁾
Setting fault ²⁾			
Test function		OFF	¹⁾
No fault after fault storage ³⁾		⁴⁾	

¹⁾ Depending on the configuration.

²⁾ Possible faulty setting: The threshold value for final switch-off is set at a higher value than the threshold value for prewarning

³⁾ The device has triggered after an insulation fault. The fault has been stored and the insulation resistance has returned to a higher value than the threshold value plus hysteresis.

⁴⁾ Depending on the fault

LEDs, status information and fault messages CM-IWS.x

Operational state	LED U (green)	LED F (red)	LED R (yellow)
Start-up		OFF	OFF
No fault		OFF	
Insulation fault (below threshold value)			OFF
Invalid measuring result			OFF
KE/⊥ wire interruption (only CM-IWS.1)			OFF
CM-IWS.1: System leakage capacitance too high / invalid measurement result			OFF
CM-IWS.2: Invalid measurement result			OFF
Internal system fault	OFF		OFF
Test function		OFF	OFF
No fault after fault storage ³⁾		⁴⁾	

Connection diagram CM-IWS.2

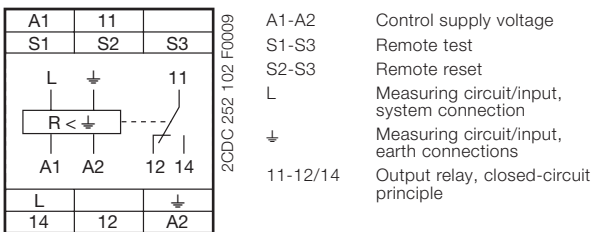

Connection diagram CM-IWS.1

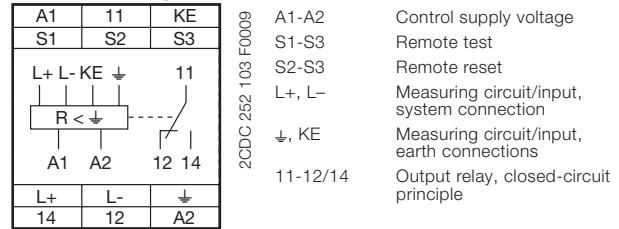

Connection diagram CM-IWN.1, 4, 5, 6

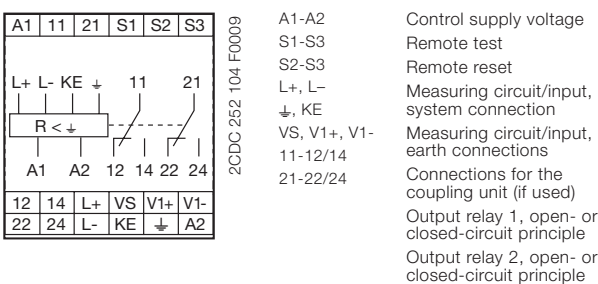

Connection diagram CM-IVN

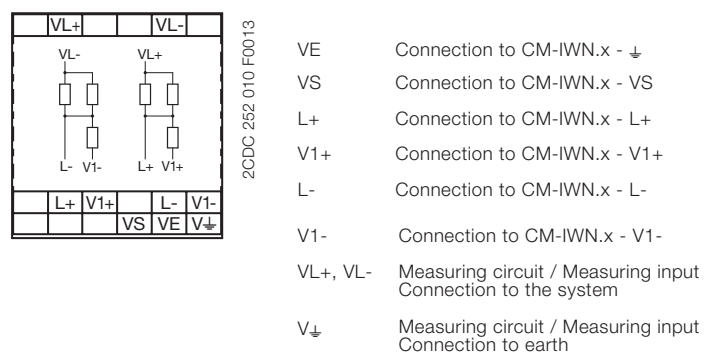

DIP switches of CM-IWN.1, 4, 5, 6

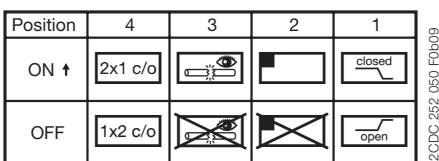

	ON	OFF (default)
DIP switch 1 Operating principle of the output relays	Closed-circuit principle <input checked="" type="checkbox"/> If closed-circuit principle is selected, the output relays de-energize in case a fault is occurring. In non-fault state the relays are energized.	Open-circuit principle <input checked="" type="checkbox"/> If open-circuit principle is selected, the output relays energize in case a fault is occurring. In non-fault state the relays are de-energized.
DIP switch 2 Non-volatile fault storage	Fault storage activated (latching) <input checked="" type="checkbox"/> If the fault storage function is activated, the output relays remain in tripped position until a reset is done either by the front-face button or by the remote reset connection S2-S3. This function is non-volatile.	Fault storage de-activated (non latching) <input checked="" type="checkbox"/> If the fault storage function is de-activated, the output relays switch back to their original position as soon as the insulation fault no longer exists.
DIP switch 3 Interrupted wire detection	Interrupted wire detection activated <input checked="" type="checkbox"/> With this configuration, the CM-IWN.1 monitoring relays the wires connected to ⊥ and KE for interruptions.	Interrupted wire detection de-activated <input checked="" type="checkbox"/> With this configuration the interrupted wire detection is de-activated.
DIP switch 4 2 x 1 c/o, 1 x 2 c/o	2 x 1 c/o (SPDT) contact <input checked="" type="checkbox"/> If operating principle 2 x 1 c/o contact is selected, the output relay R1 (11-12/14) reacts to threshold value R1 (final switch-off) and the output relay R2 (21-22/24) reacts to threshold value R2 (prewarning)	1 x 2 c/o (SPDT) contacts <input checked="" type="checkbox"/> If operating principle 1 x 2 c/o contacts is selected, both output relays R1 (11-12/14) and R2 (21-22/24) react synchronously to threshold value R1. Settings of the threshold value R2 have no effect on the operation.

Insulation monitoring relays for unearthed supply systems

Technical data

Data at $T_a = 25\text{ °C}$ and rated values, unless otherwise indicated

		CM-IWS.2	CM-IWS.1	CM-IWN.1, 4, 5, 6
Input circuit - Supply circuit		A1 - A2		
Rated control supply voltage U		24-240 V AC/DC		
Rated control supply voltage tolerance		-15...+10 %		
Typical current / power consumption		24 V DC 30 mA / 0.7 VA	35 mA / 0.9 VA	55 mA / 1.3 VA
		115 V AC 12 mA / 1.4 VA	17 mA / 2.0 VA	20 mA / 2.3 VA
		230 V AC 12 mA / 2.8 VA	14 mA / 3.2 VA	15 mA / 3.5 VA
Rated frequency f		DC or 15-400 Hz		
Frequency range AC		13.5-440 Hz		
Power failure buffering time	min.	20 ms		
Input circuit - Measuring circuit		L, ↓	L+, L-, ↓, KE	L+, L-, ↓, KE
Monitoring function		insulation resistance monitoring of IT systems (IEC/EN 61557-8)		
Measuring principle		superimposed DC voltage	prognostic measuring principle with superimposed square wave signal	
Nominal voltage U_n of the distribution system to be monitored		0-400 V AC	0-250 V AC / 0-300 V DC	400 V AC / 0-600 V DC
Voltage range of the distribution system to be monitored		0-460 V AC (tolerance +15 %)	0-287.5 V AC / 0-345 V DC (tolerance +15 %)	0-460 V AC / 0-690 V DC (tolerance +15 %)
Rated frequency f_N of the distribution system to be monitored		50-60 Hz	DC or 15-400 Hz	DC or 15-400 Hz
System leakage capacitance C_e	max.	10 μ F		CM-IWN.1: 20 μ F CM-IWN.4: 500 μ F CM-IWN.5: 1000 μ F CM-IWN.6: 2000 μ F
Tolerance of the rated frequency f_N		45-65 Hz	13.5-440 Hz	13.5-440 Hz
Extraneous DC voltage U_g (when connected to an AC system)	max.	none	290 V DC	460 V DC
Number of possible response / threshold values		1		2
Adjustment range of the specified response value R_{an} (threshold)	min.-max.	1-100 k Ω		-
	min.-max. R1	-		1-100 k Ω
	min.-max. R2	-		2-200 k Ω (activated / de-activated by DIP-switch)
Adjustment resolution		1 k Ω R1 1 k Ω R2 -		1 k Ω 2 k Ω -
Tolerance of the adjusted threshold value / Relative percentage uncertainty A at -5...+45 °C, $U_n = 0-115\%$, $U_s = 85-110\%$, $f_N, f_s, C_e = 1\mu$ F		at 1-10 k Ω R_F $\pm 0.5\%$ at 10-100 k Ω R_F $\pm 6\%$ at 1-15 k Ω R_F - at 15-200 k Ω R_F -		- - $\pm 1\text{ k}\Omega^*$ $\pm 8\%$
Hysteresis related to the threshold value		25 %; min. 2 k Ω		
Internal impedance Z_i	at 50 Hz	135 k Ω	100 k Ω	155 k Ω
Internal DC resistance R_i		185 k Ω	115 k Ω	185 k Ω
Measuring voltage U_m		15 V	22 V	24 V
Tolerance of measuring voltage U_m		+10 %		
Measuring current I_m	max.	0.1 mA	0.3 mA	0.15 mA
Response time t_{an}		pure AC system DC system or AC system with connected rectifiers	0.5 x R_{an} and $C_e = 1\mu$ F	max. 10 s max. 15 s
Repeat accuracy (constant parameters)		< 0.1 % of full scale		
Accuracy of R_a (measured value) within the rated control supply voltage tolerance		< 0.05 % of full scale		
Accuracy of R_a (measured value) within the operation temperature range		at 1-10 k Ω R_F 5 W / K at 10-100 k Ω R_F 0.05 % / K at 10-200 k Ω R_F -		- 0.05 % / K
Transient overvoltage protection (\perp - terminal)		Z-diode	avalanche diode	
Input circuit - Control circuits		S1 - S2 - S3		
Control inputs - volt free	S1-S3 S2-S3	remote test remote reset		
Maximum switching current in the control circuit		1 mA		
Maximum cable length to the control inputs		50 m - 100 pF/m [164 ft - 30.5 pF/ft]		
Minimum control pulse length		150 ms		
No-load voltage at the control input		$\leq 24\text{ V} \pm 5\%$		$\leq 24\text{ V DC}$

*in combination with CM-IWN $\pm 1.5\text{ k}\Omega$

Insulation monitoring relays for unearthed supply systems

Technical data

2

		CM-IWS.2	CM-IWS.1	CM-IWN.1, 4, 5, 6
Indication of operational states				
Control supply voltage		LED U (green)		
Fault message		LED F (red)		
Relay status		LED R (yellow)		
Output circuits				
Kind of output		relay, 1 c/o (SPDT) contact		2 x 1 or 1 x 2 c/o (SPDT) contacts configurable
Operating principle		closed-circuit principle ¹⁾		open- or closed circuit principle ¹⁾ configurable
Contact material		AgNi alloy, Cd free		
Rated voltage (VDE 0110, IEC 60947-1)		250 V AC / 300 V DC		
Min. switching voltage / Min. switching current		24 V / 10 mA		
Max. switching voltage / Max. switching current		see data sheet		
Rated operational current I _o (IEC/EN 60947-5-1)	AC12 (resistive) at 230 V	4 A		
	AC15 (inductive) at 230 V	3 A		
	DC12 (resistive) at 24 V	4 A		
	DC13 (inductive) at 24 V	2 A		
AC rating (UL 508)	Utilization category (Control Circuit Rating Code)	B 300, pilot duty general purpose (250 V, 4 A, cos φ 0.75)		
	max. rated operational voltage	250 V AC		
	max. continuous thermal current at B 300	4 A		
	max. making/breaking apparent power at B 300	3600/360 VA		
Mechanical lifetime		30 x 10 ⁸ switching cycles		
Electrical lifetime (AC12, 230 V, 4 A)		0.1 x 10 ⁸ switching cycles		
Max. fuse rating to achieve short-circuit protection	n/c contact	6 A fast-acting		
	n/o contact	10 A fast-acting		
Conventional thermal current I _m (IEC/EN 60947-1)		4 A		
General data				
Duty time		100 %		
Dimensions (W x H x D)	product dimension	22.5 x 85.6 x 103.7 mm (0.89 x 3.37 x 4.08 in)		45 x 85.6 x 103.7 mm (0.89 x 3.37 x 4.08 in)
	packaging dimension	97 x 109 x 30 mm (3.82 x 4.29 x 1.18 in)		97 x 109 x 30 mm (3.82 x 4.29 x 1.18 in)
Weight	grossweight	CM-IWS.2P:	CM-IWS.1P:	CM-IWN.xP:
		0.130 kg (0.287 lb)	0.137 kg (0.302 lb)	0.217 kg (0.478 lb)
	CM-IWS.2S:	CM-IWS.1S:	CM-IWN.xS:	
	0.141 kg (0.311 lb)	0.148 kg (0.326 lb)	0.241 kg (0.531 lb)	
netweight	CM-IWS.2P:	CM-IWS.1P:	CM-IWN.xP:	
	0.155 kg (0.342 lb)	0.162 kg (0.357 lb)	0.246 kg (0.542 lb)	
	CM-IWS.2S:	CM-IWS.1S:	CM-IWN.xS:	
	0.166 kg (0.366 lb)	0.173 kg (0.381 lb)	0.270 kg (0.595 lb)	
Mounting		DIN rail (IEC/EN 60715), snap-on mounting without any tool		
Mounting position		any		
Minimum distance to other units	vertical	not necessary		10 mm (0.39 in)
	horizontal	10 mm (0.39 in) at U _n > 240 V	not necessary	10 mm (0.39 in) at U _n > 400 V
Material of housing		UL 94 V-0		
Degree of protection	housing / terminal	IP50 / IP20		
Electrical connection				
		Screw connection technology		Easy Connect Technology (Push-in)
Wire size	fine-strand with(out) wire end ferrule	1 x 0.5-2.5 mm ² (1 x 20-14 AWG) 2 x 0.5-1.5 mm ² (2 x 20-16 AWG)		2 x 0.5-1.5 mm ² (2 x 20-16 AWG)
	rigid	1 x 0.5-4 mm ² (1 x 20-12 AWG) 2 x 0.5-2.5 mm ² (2 x 20-14 AWG)		2 x 0.5-1.5 mm ² (2 x 20-16 AWG)
Stripping length		8 mm (0.32 in)		
Tightening torque		0.6-0.8 Nm (5.31-7.08 lb.in)		

¹⁾ Closed-circuit principle: Output relay(s) de-energize(s) if a fault is occurring
Open-circuit principle: Output relay(s) energize(s) if a fault is occurring

Insulation monitoring relays for unearthed supply systems

Technical data

2

		CM-IWS.2	CM-IWS.1	CM-IWN.1, 4, 5, 6
Environmental data				
Ambient temperature ranges	operation / storage / transport	-25...+60 °C/-40...+85 °C/-40...+85 °C		
Climatic category	IEC/EN 60721-3-3	3K5 (no condensation, no ice formation)		
Damp heat, cyclic	IEC/EN 60068-2-30	6 x 24 h cycle, 55 °C, 95 % RH		
Vibration, sinusoidal	IEC/EN 60255-21-1	Class 2		
Shock, half-sine	IEC/EN 60255-21-2	Class 2		
Isolation data				
Rated impulse withstand voltage U_{imp} between all isolated circuits (IEC/EN 60947-1, IEC/EN 60664-1, VDE 0110-1)	supply / measuring circuit	6 kV		
	supply / output circuit	6 kV		
	measuring / output circuit	6 kV		
	output 1 / output circuit 2	4 kV		
Pollution degree (IEC/EN 60664-1, VDE 0110-1)		3		
Overvoltage category (IEC/EN 60664-1, VDE 0110-1)		III		
Rated insulation voltage U_i (IEC/EN 60947-1, IEC/EN 60664-1, VDE 0110-1)	supply / measuring circuit	400 V	300 V	600 V
	supply / output circuit	300 V		
	supply / measuring circuit	400 V	300 V	600 V
	output 1 / output circuit 2	-	-	300 V
Basis isolation for rated control supply voltage (IEC/EN 60664-1, VDE 0110-1)	supply / measuring circuit	400 V AC / 300 V DC	250 V AC / 300 V DC	400 V AC / 600 V DC
	supply / output circuit	250 V AC / 300 V DC		
	measuring / output circuit	400 V AC / 300 V DC	250 V AC / 300 V DC	400 V AC / 600 V DC
	output 1 / output 2	250 V AC / 300 V DC		
Protective separation (IEC/EN 61140)	supply / output circuit	250 V AC / 250 V DC		
	supply / measuring circuit	250 V AC / 250 V DC		
	measuring / output circuit	250 V AC / 250 V DC		
	output 1 / output 2	250 V AC / 250 V DC		
Test voltage between all isolated circuits, routine test (IEC/EN 60255-5, IEC/EN 61010-1)	supply / output circuit	2.32 kV, 50 Hz, 2 s		
	supply / measuring circuit	2.32 kV, 50 Hz, 2 s		
	measuring / output circuit	2.2 kV, 50 Hz, 1 s		
		2.53 kV, 50 Hz, 1 s		
Standards				
Product standard		IEC/EN 61557-8, IEC/EN 60255-6		
Other standards		EN 50178		
Low Voltage Directive		2006/95/EC		
EMC Directive		2004/108/EC		
RoHS Directive		2002/95/EC		
Electromagnetic compability				
Interference immunity to		IEC/EN 61000-6-1, IEC/EN 61000-6-2, IEC/EN 61326-2-4		
electrostatic discharge	IEC/EN 61000-4-2	Level 3, 6 kV / 8 kV		
radiated, radio-frequency, electromagnetic field	IEC/EN 61000-4-3	Level 3, 10 V/m (1 GHz) / 3 V/m (2 GHz) / 1 V/m (2.7 GHz)		
electrical fast transient/burst	IEC/EN 61000-4-4	Level 3, 2 kV / 5 kHz		
surge	IEC/EN 61000-4-5	Level 3, installation class 3, supply circuit and measuring circuit 1 kV L-L, 2 kV L-earth		
conducted disturbances, induced by radio-frequency fields	IEC/EN 61000-4-6	Level 3, 10 V		
voltage dips, short interruptions and voltage variations	IEC/EN 61000-4-11	Class 3		
harmonics and interharmonics	IEC/EN 61000-4-13	Class 3		
Interference emissions		IEC/EN 61000-6-3, IEC/EN 61000-6-4		
high-frequency radiated	IEC/CISPR 22, EN 55022	Class B		
high-frequency conducted	IEC/CISPR 22, EN 55022	Class B		

Insulation monitoring relays for unearthed supply systems

Technical data CM-IVN

2

Input circuit - Measuring circuit		VL+, VL-, V+
Function		expansion of the nominal voltage range of the insulation monitoring relay CM-IWN to 690 V AC or 1000 V DC, max. length of connection cable 40 cm see CM-IWN
Measuring principle		
Nominal voltage U_n of the distribution system to be monitored		0-690 V AC / 0-1000 V DC
Voltage range of the distribution system to be monitored		0-793.5 V AC / 0-1150 V DC (tolerance +15 %)
Rated frequency f_N of the distribution system to be monitored		DC or 15-400 Hz
Tolerance of the rated frequency f_N		13.5-440 Hz
System leakage capacitance C_e	max.	identical to that of the insulation monitoring relay used
Extraneous DC voltage U_{ig} (when connected to an AC system)	max.	793.5 V DC
Tolerance of the adjusted threshold value / Relative percentage uncertainty A at $-5...+45\text{ }^\circ\text{C}$, $U_n = 0-115\%$, $U_s = 85-110\%$, $f_N, f_s, C_e = 1\text{ }\mu\text{F}$	at 1-15 k Ω R_F at 15-200 k Ω R_F	$\pm 1.5\text{ k}\Omega$ $\pm 8\%$
Internal impedance Z_i	at 50 Hz	195 k Ω
Internal DC resistance R_i		200 k Ω
Measuring voltage U_m		24 V
Tolerance of measuring voltage U_m		+10 %
Measuring current I_m		0.15 mA
General data		
MTBF		on request
Duty time		100 %
Dimensions (W x H x D)		45 x 78 x 100 mm (1.78 x 3.07 x 3.94 in)
Weight	gross weight net weight	0.200 kg (0.441 lb) 0.169 kg (0.373 lb)
Mounting		DIN rail (IEC/EN 60715), snap-on mounting without any tool
Mounting position		any
Minimum distance to other units	vertical horizontal	not necessary 10 mm (0.39 in) at $U_n > 600\text{ V}$
Degree of protection		IP50 / IP20
Electrical connection		
Wire size	fine-strand with(out) wire end ferrule rigid	2 x 0.75-2.5 mm ² (2 x 18-14 AWG) 2 x 0.5-4 mm ² (2 x 20-12 AWG)
Stripping length		7 mm (0.28 in)
Tightening torque		0.6-0.8 Nm (5.31-7.08 lb.in)
Max. length of connection cable to CM-IWN		40 cm
Environmental data		
Ambient temperature ranges	operation / storage / transport	-25...+60 °C / -40...+85 °C / -40...+85 °C
Climatic category	IEC/EN 60721-3-3	3K5 (no condensation, no ice formation)
Damp heat, cyclic	IEC/EN 60068-2-30	6 x 24 h cycle, 55 °C, 95 % RH
Vibration, sinusoidal	IEC/EN 60255-21-1	Class 2
Shock, half-sine	IEC/EN 60255-21-2	Class 2
Isolation data		
Rated impulse withstand voltage U_{imp} between all isolated circuits (IEC/EN 60947-1, IEC/EN 60664-1, VDE 0110-1)	input circuit / PE	8 kV
Pollution degree (IEC/EN 60664-1, VDE 0110-1)		3
Overvoltage category (IEC/EN 60664-1, VDE 0110-1)		III
Rated insulation voltage U_i (IEC/EN 60947-1, IEC/EN 60664-1, VDE 0110-1)	input circuit / PE	1000 V
Test voltage between all isolated circuits, routine test (IEC/EN 60255-5, IEC/EN 61010-1)	input circuit / PE	3.3 kV, 50 Hz, 1 s
Standards		
Product standard		IEC/EN 61557-8, IEC/EN 60255-6
Other standards		EN 50178
Low Voltage Directive		2006/95/EC
EMC Directive		2004/108/EC
RoHS Directive		2002/95/EC
Electromagnetic compatibility		
Interference immunity to		IEC/EN 61000-6-1, IEC/EN 61000-6-2, IEC/EN 61326-2-4
electrostatic discharge	IEC/EN 61000-4-2	Level 3, 6 kV / 8 kV
radiated, radio-frequency, electromagnetic field	IEC/EN 61000-4-3	Level 3, 10 V/m (1 GHz) / 3 V/m (2 GHz) / 1 V/m (2.7 GHz)
electrical fast transient/burst	IEC/EN 61000-4-4	Level 3, 2 kV / 5 kHz
surge	IEC/EN 61000-4-5	Level 3, installation class 3, supply circuit and measuring circuit 1 kV L-L, 2 kV L-earth
conducted disturbances, induced by radio-frequency fields	IEC/EN 61000-4-6	Level 3, 10 V
voltage dips, short interruptions and voltage variations	IEC/EN 61000-4-11	Level 3
harmonics and interharmonics	IEC/EN 61000-4-13	Level 3
Interference emission		IEC/EN 61000-6-3, IEC/EN 61000-6-4
high-frequency radiated	IEC/CISPR 22, EN 50022	Class B
high-frequency conducted	IEC/CISPR 22, EN 50022	Class B

Insulation monitoring relays for unearthed supply systems

Notes

Lined area for notes, consisting of numerous horizontal blue dotted lines.

Motor load monitoring relays

Product picture

2



Motor load monitoring relays

Table of contents

Motor load monitoring relays	
Product picture	77
Table of contents	78
Fields of application	79
Ordering details	80
Technical information	81
Technical data	82

Motor load monitoring relays

Fields of application

The motor load monitor relay monitors the load states of single-phase and three-phase asynchronous motors. The evaluation of the phase angle between current and voltage allows a very precise monitoring of the load states.

Compared with other conventional measuring principles (e.g. pressure transducers, current measurement), $\cos \varphi$ monitoring is a more precise and economical alternative. The motor is used as a sensor for its own load status.

2 Main applications

- Pump monitoring
 - Dry-running protection (underload)
 - Closed valves (overload)
 - Pipe break (overload)
- Heating, air-conditioning, ventilation
 - Monitoring of filter pollution
 - V-belt breakage (underload)
 - Closed shutters/valves (overload)
 - Air ventilating volume
- Agitating machines
 - High consistency within the tank (overload)
 - Pollution of the tank (overload)
- Transport/Conveyance
 - Congested conveyor belts (overload)
 - Jamming of belts (overload)
 - Material accumulation in spiral conveyors (overload)
 - Lifting platforms
- Machine installation
 - Wear of tools, e.g. worn saw blades in circular saws, etc. (overload)
 - Tool breakage (underload)
 - V-belt drives (breakage underload)

Pump control

Dry-running protection

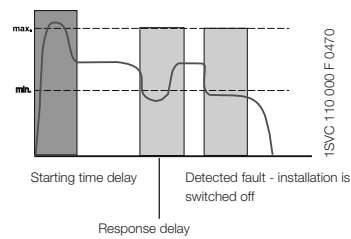

Filter pollution

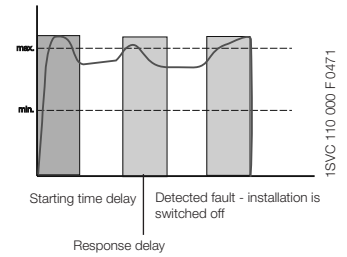

Ventilator monitoring

V-belt monitoring

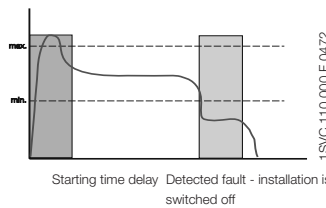

Filter pollution

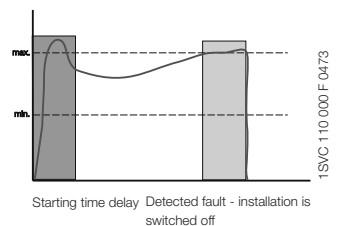

Wiring examples (for motor currents ≤ 20 A)

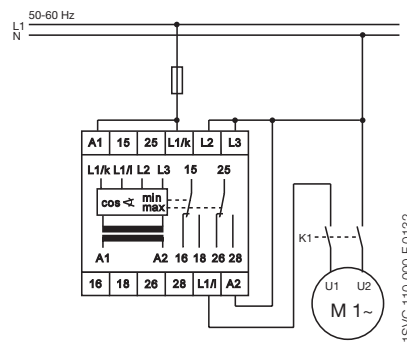
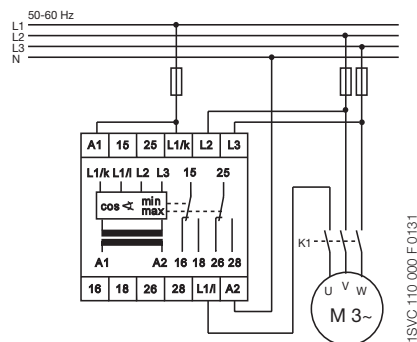

Wiring examples (for motor currents ≥ 20 A)

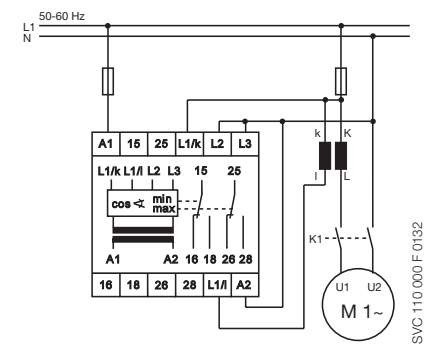
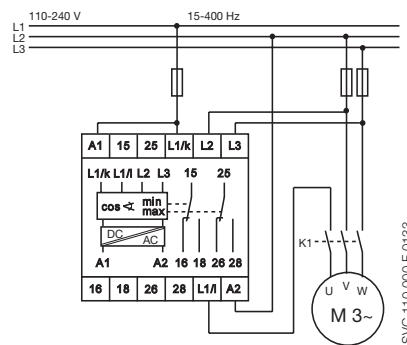
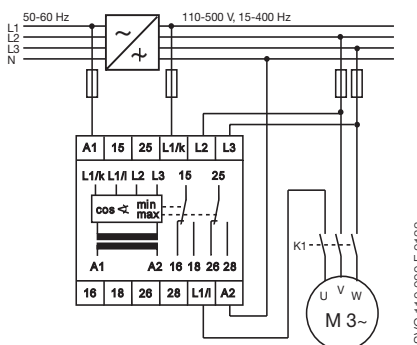
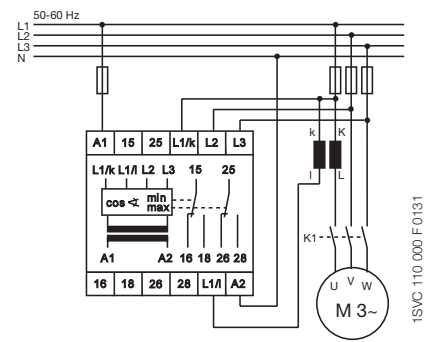

• Current transformers 2/103

Motor load monitoring relays

Ordering details

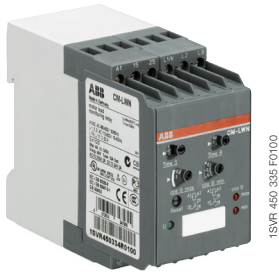

CM-LWN

Description

The motor load monitor CM-LWN monitors the load of single-phase and three-phase asynchronous motors. The evaluation of the phase angle between current and voltage ($\cos \varphi$ monitoring) allows a very precise monitoring of the load status.

Ordering details

Rated control supply voltage = measuring voltage	Current range	Type	Order code	Price	Weight (1 pce)
				1 pce	kg (lb)
24-240 V AC/DC	0.5-5 A	CM-LWN	1SVR450335R0000		0.30 (0.66)
110-130 V AC			1SVR450330R0000		0.30 (0.66)
220-240 V AC			1SVR450331R0000		0.30 (0.66)
380- 440 V AC			1SVR450332R0000		0.30 (0.66)
480-500 V AC			1SVR450334R0000		0.30 (0.66)
24-240 V AC/DC	2-20 A		1SVR450335R0100		0.30 (0.66)
110-130 V AC			1SVR450330R0100		0.30 (0.66)
220-240 V AC			1SVR450331R0100		0.30 (0.66)
380- 440 V AC			1SVR450332R0100		0.30 (0.66)
480-500 V AC			1SVR450334R0100		0.30 (0.66)

Current transformers see page 2/132.

Characteristics

- Pump monitoring
- Under- and overload monitoring $\cos \varphi$ in one unit
- Adjustable starting delay 0.3-30 s
- Direct measurement of currents up to 20 A
- Adjustable response time delay 0.2-2 s
- Single-phase or three-phase monitoring
- 2 x 1 c/o contact, closed-circuit principle
- 3 LEDs for status indication

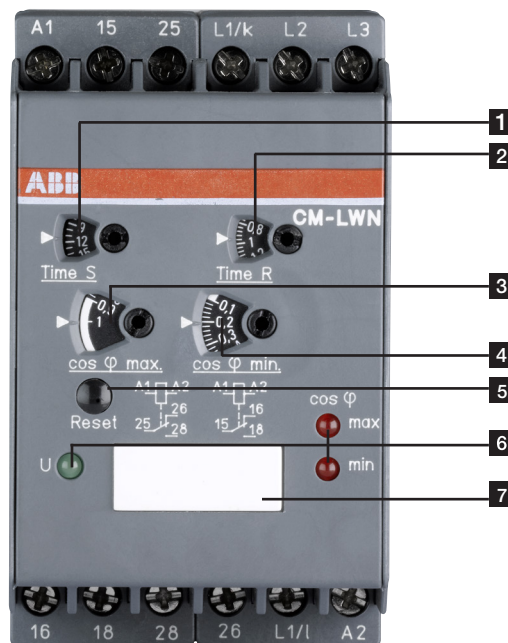

- 1 Starting delay „Time S“
- 2 Response delay „Time R“
- 3 Threshold for load limit $\cos \varphi_{\max}$
- 4 Threshold for load limit $\cos \varphi_{\min}$
- 5 Reset button
- 6 Indication of operational states
U: green LED – control supply voltage
 $\cos \varphi_{\max}$: red LED – $\cos \varphi_{\max}$ exceeded
 $\cos \varphi_{\min}$: red LED – below $\cos \varphi_{\min}$
- 7 Marker label

Motor load monitoring relays

Technical information

2

The **CM-LWN** module monitors the load status of inductive loads.

The primary application is the monitoring of single- or three-phase asynchronous motors (squirrel cage) under varying load conditions. The measuring principle is based on the evaluation of the phase shift (φ) between the voltage and the current in one phase.

The phase difference is nearly inversely proportional to the load. Therefore, $\cos \varphi$, measured relatively from 0 to 1, measures the relationship of effective power to apparent power. A value towards 0 indicates low load and a value towards 1 indicates high load.

Threshold values can be set individually for $\cos \varphi_{\max}$ and $\cos \varphi_{\min}$. If the set threshold value is reached, a LED lights up and the relay is de-energized.

If $\cos \varphi$ returns to the acceptable limits (taking into account the hysteresis), the relay is reset to its original state and the LED flashes permanently to indicate the occurrence of the trip event. This message can be deleted using the reset button or by switching off the supply.

A time delay (Time S) of 0.3 to 30 s can be set for the starting phase of the motor. It is also possible to set a response delay time (Time R) of 0.2 to 2 s to suppress unwanted tripping due to unavoidable short load changes during normal operation.

To guarantee correct operation of the response delay (Time R), the adjusted value for $\cos \varphi_{\max}$ has to be higher than the value for $\cos \varphi_{\min}$ plus the hysteresis. Consequently, the overload and underload indication must not be active at the same time.

Due to the internal electrical isolation of the supply circuit and the measuring circuit, it is also possible to use the device in systems with different supply voltages.

Function diagram - CM-LWN

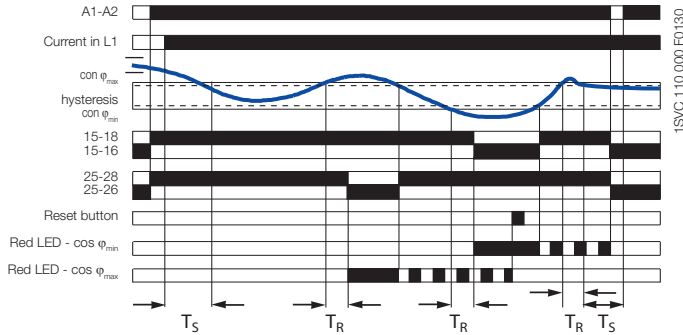

Connection diagram CM-LWN

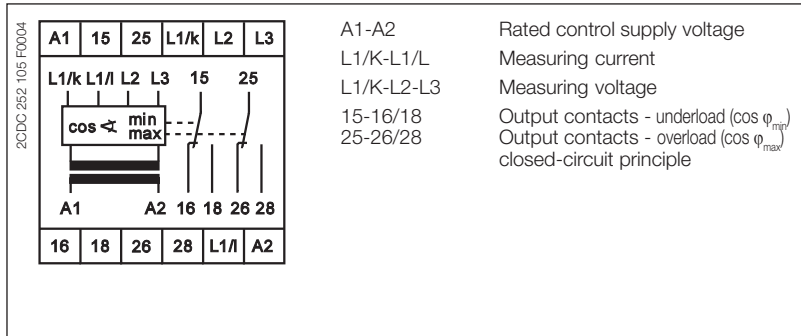

Motor load monitoring relays

Technical data

Type		CM-LWN A1-A2
Input circuit - Supply circuit		
Rated control supply voltage U_s - power consumption	A1-A2	24-240 V AC/DC approx. 8.4 VA/W
	A1-A2	110-130 V AC approx. 3.6 VA
	A1-A2	220-240 V AC approx. 3.6 VA
	A1-A2	380-440 V AC approx. 3.6 VA
	A1-A2	480-500 V AC approx. 3.6 VA
Rated control supply voltage U_s tolerance		-15 %...+10 %
Rated frequency	AC versions	50-60 Hz
	AC/DC versions	15-400 Hz or DC
Duty time		100 %
Measuring circuit		L1/L-L1/K-L2-L3
Monitoring function		Motor load monitoring by $\cos \phi$
Voltage range	L1/K-L2-L3	110-500 V AC single-phase or three-phase
Current range	L1/L-L1/K	0.5-5 A version 2-20 A version
Permissible overload of current input		25 A for 3 s / 100 A for 3 s
Thresholds		$\cos \phi_{\min}$ and $\cos \phi_{\max}$ adjustable from 0 to 1
Hysteresis (related to phase angle ϕ in °)		4°
Frequency of measuring voltage		15-400 Hz
Response time		300 ms
Timing circuits		indication of over- and undervoltage fault
Start-up time (Time S)		0.3-30 s, adjustable
Response delay (Time R)		0.2-2 s, adjustable
Accuracy within the rated control supply voltage tolerance		$\Delta t \leq 0.5 \%$
Accuracy within the temperature range		$\Delta t \leq 0.06 \%$ / °C
Indication of operational states		
Control supply voltage		U: green LED
below $\cos \phi_{\min}$		$\cos \phi_{\min}$: red LED
$\cos \phi_{\max}$ exceeded		$\cos \phi_{\max}$: red LED
Output circuits		15-16/18, 25-26/28
Kind of output		2 x 1 c/o contact
Operational principle		closed-circuit principle ¹⁾
Contact material		AgCdO
Rated voltage (VDE 0110, IEC 664-1, IEC 947-1)		250 V
Max. switching voltage		400 V AC, 300 V DC
Rated operational current I_b (IEC/EN 60947-1)	AC12 (resistive) 230 V	4 A
	AC15 (inductive) 230 V	3 A
	DC12 (resistive) 24 V	4 A
	DC13 (inductive) 24 V	2 A
AC rating (UL 508)	Utilization category (Control Circuit Rating Code)	B 300
	max. rated operational voltage	300 V AC
	max. continuous thermal current at B 300	5 A
	max. making/breaking apparent power at B 300	3600/360 VA
Mechanical lifetime		30×10^6 switching cycles
Electrical lifetime	at AC12, 230 V, 4 A	0.1×10^6 switching cycles
Max. fuse rating to achieve short-circuit protection	n/c / n/o contact	10 A fast-acting / 10 A fast-acting
General data		
Dimensions (W x H x D)		45 mm x 78 mm x 100 mm (1.77 inch x 3.07 inch x 3.94 inch)
Mounting position		any
Degree of protection	housing / terminals	IP50 / IP20
Ambient temperature range	operation / storage	-25...+65 °C / -40...+85 °C
Mounting		DIN rail (IEC/EN 60715)
Electrical connection		
Wire size	fine-strand with wire end ferrule	2 x 2.5 mm ² (2 x 14 AWG)
Standards		
Product standard		IEC 255-6, EN 60255-6
Low Voltage Directive		2006/95/EC
EMC Directive		2004/108/EC, 91/263/EEC, 92/31/EEC, 93/68/EEC, 93/67/EEC
Electromagnetic compatibility		EN 61000-6-2, EN 61000-6-4
electrostatic discharge	IEC/EN 61000-4-2	Level 3 (6 kV / 8 kV)
radiated, radio-frequency, electromagnetic field	IEC/EN 61000-4-3	Level 3 (10 V/m)
electrical fast transient / burst	IEC/EN 61000-4-4	Level 3 (2 kV / 5 kHz)
surge	IEC/EN 61000-4-5	Level 4 (2 kV L-L)
conducted disturbances, induced by radio-frequency fields	IEC/EN 61000-4-6	Level 3 (10 V)
Operational reliability (IEC 68-2-6)		5 g
Mechanical resistance (IEC 68-2-6)		10 g
Environmental testing (IEC 68-2-30)		24 h cycle time, 55 °C, 93 % rel., 96 h
Isolation data		
Rating (HD 625.1 S1, VDE 0110, IEC 664-1, IEC 60255-5)		
Rated insulation voltage between supply- measuring- and output circuit		250 V, 400 V, 500 V depending on the version
Rated impulse withstand voltage between all isolated circuits		4 kV / 1.2 - 50 μ s
Test voltage between all isolated circuits		2.5 kV, 50 Hz, 1 min.
Pollution category		3
Overvoltage category		III

¹⁾ Open-circuit principle: Output relay is energized if the measured value exceeds/drops below the adjusted threshold.

Closed-circuit principle: Output relay is de-energized if the measured value exceeds/drops below the adjusted threshold.

Motor control and protection

Product group picture

2



Motor control and protection

Table of contents

Motor control and protection	
Product group picture	83
Table of contents	84
Benefits and advantages	85
Technical data	86
Notes	88

Motor control and protection

Benefits and advantages

2

UMC100-FBP is a flexible, modular and expandable motor management system for constant-speed low-voltage range motors.

It's most important tasks include motor protection, prevention of plant standstills and the reduction of down time. This is made possible by early information relating to possible motor problems which avoids unplanned plant standstills. Even if a motor trips, quick diagnosis of the cause of the fault serves to reduce downtime.

UMC100-FBP combines in a very compact unit:

Motor protection

- Overload, underload
- Overvoltage, undervoltage
- Blocked rotor, low / high current
- Phase failure, imbalance, phase sequence
- Earth leakage
- Thermistor protection
- Limitation of starts per time
- One single version with integrated measuring system covers the rated motor current from 0,24 to 63 A

Motor control

- Integrated and easy to parametrize motor starter functions like direct, reverse, star-delta,...
- Additionally free programmable logic for application specific control functions
- Expansion modules DX111, DX122 for more I/Os
- Expansion modules VI150, VI155 for 3-phase voltage measuring

Motor diagnostics

- Quick and comprehensive access to all relevant data via fieldbus and/or operator panel
- Current, thermal load
- Phase voltages
- Power factor
- Energy

Communication

- Communication-independent basic device
- Freely selectable fieldbus protocol with FieldBusPlug
- Profibus DP
- DeviceNet
- Modbus RTU
- Ethernet Modbus TCP
- CANopen

Typical application segments

- Oil & gas
- Cement
- Paper
- Mining
- Steel
- Chemical industry

Further information

UMC & FBP Catalog 2CDC 190 022 C0205

UMC & FBP Brochure 2CDC 135 011 B0203

Motor control and protection

Technical data



Basic device UMC100-FBP

UMC100-FBP allows the connection of one I/O-expansion module DX111 or DX122, and one voltage module VI150 or VI155. Expansion modules are connected via 2-wire bus, the max. distance to UMC100-FBP is 3 m.

Main power	
Voltage	max 1000 V AC
Frequency	45 to 65 Hz
Rated motor current	0.24 to 63 A, without accessories
	Greater currents with transformer
Transformer diameter	11 mm (max 25 mm ²)
Tripping classes	5, 10, 20, 30, 40 in accordance with EN/IEC 60947-4-1
Short-circuit protection	Separate fuse on network side

Control unit	
Supply voltage	24 V DC
Reverse polarity protection	yes
Inputs	6 digital inputs 24 V DC
	1 PTC input
Outputs	3 relay outputs relay
	1 digital output transistor
Interfaces	1 for ABB FieldBusPlug
	1 for UMC100-PAN control station
	1 for expansion module
Parametric assignment	via fieldbus, control station and / or software
Addressing	Control station or addressing set
LEDs	3 LEDs: green, yellow, red

Environment and mechanical data	
Fastening	on DIN busbar (EN50022-35) or with 4 screws x M4
Dimensions (W x H x D)	70 x 105 x 110 mm (incl. FieldBusPlug and control panel)
Weight	0.39 kg
Terminal cross-section	max. 2.5 mm ² or 2 x 1.5 mm ²

I/O-expansion modules DX111 / DX122

Expansion modules to increase the number of I/Os of a UMC100-FBP. Easy use of inputs by parametrizing for fault or warning; individual message on operator panel configurable.

Supply voltage	24 V DC	
Inputs	DX111	8 digital inputs 24 V DC
	DX122	8 digital inputs 110/230 V AC
Outputs	4 relay outputs relay	
	1 analogue output, 0/4 to 20 mA / 0 to 10 V configurable	
Fastening	on DIN busbar (EN50022-35)	
Dimensions (W x H x D)	45 x 77 x 100 mm (without terminal block)	



Motor control and protection

Technical data

2



Voltage expansion modules

Measures the 3 phase voltages of a motor. Different versions for use in grounded and ungrounded networks.

Supply voltage		24 V DC
Inputs	VI150	3 analogue inputs 150 - 690 V AC
		For use in grounded networks
	VI155	3 analogue inputs 150 - 690 V AC
		For use in all networks
Outputs		1 relay output
Fastening		on DIN busbar (EN50022-35)
Dimensions (W x H x D)		22.5 x 77 x 100 mm (without terminal block)

Ethernet-Modbus TCP interface MTQ22-FBP

Ethernet connectivity for up to four UMC100. Supports all network topologies.

Supply voltage		24 V DC (+30 % ... -20 %) (19.2 ... 31.2 V DC) including ripple
Current consumption		Max. 180 mA (at 19.2 ... 31.2 V DC)
Pollution degree terminals		3
Total power dissipation		max. 3.5 W
Short-circuit protection at port 1 ... 4		PTC resistor
Reverse polarity protection of supply inputs		Yes

Thermistor motor protection relays

Product group picture

2



Thermistor motor protection relays

Table of contents

Thermistor motor protection relays	
Product group picture	89
Table of contents	90
Benefits and advantages, Applications	91
Operating controls	92
Selection table thermistor motor protection relays	93
Ordering details	94
Ordering details - PTC temperature sensors C011	95
Technical data	96
Connection diagrams	98

Thermistor motor protection relays

Benefits and advantages, Applications

Operating principle and fields of application for thermistor motor protection relays

The CM range of thermistor motor protection relays are used to control motors equipped with PTC temperature sensors. The PTC temperature sensors are incorporated in the motor windings to measure the motor heating. This enables direct control and evaluation of the following operating conditions:

2

- heavy duty starting
- increased switching frequency
- single-phase operation
- high ambient temperature
- insufficient cooling
- break operation
- unbalance

The relay is independent of the rated motor current, the insulation class and the method of starting.

The PTC sensors are connected in series to the terminals T_a and T_b (or T_a and T_{bx} without short-circuit detection). The number of possible PTC sensors per measuring circuit is limited by the sum of the individual PTC sensor resistances: $R_G = R_1 + R_2 + R_N \leq 1.5 \text{ k}\Omega$.

Under normal operating conditions the resistance is below the response threshold. If only one of the PTC resistors heats up excessively, the output relay de-energizes. If the autoreset function is configured, the output relay energizes automatically after cooling down.

Devices with manual (push button on front-side) or remote reset configuration have to be controlled via the control input by the required signal.

Further applications:

Temperature monitoring of equipment with PTC sensors integrated, such as:

- machine rolling bearings,
- hot-air ventilators,
- oil,
- air,
- heating installations, etc.

Resistance characteristic

for one single temperature sensor acc. to DIN 44 081.

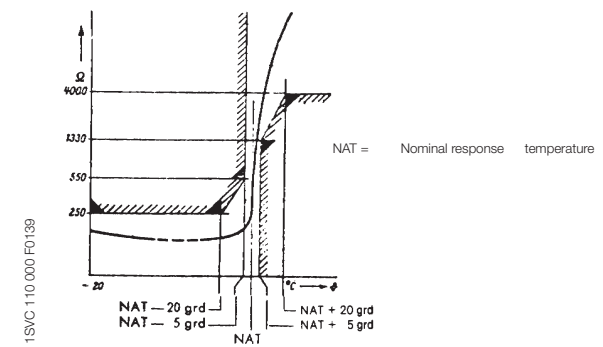

CM-MSE

- Auto reset
- Connection of several sensors (max. 6 sensors conn. in series)
- Monitoring of bimetals
- 1 n/o contact
- Excellent cost / performance ratio

CM-MSS (1), 1 c/o contact

- Auto reset
- Connection of several sensors
- Monitoring of bimetals
- 1 c/o contact
- 2 LEDs for status indication

CM-MSS (2), 2 c/o contacts

- Fault storage can be switched off
- Auto reset configurable
- Reset button
- Remote reset
- Monitoring of bimetals
- 2 c/o contacts
- 2 LEDs for status indication

CM-MSS (3), 2 c/o contacts, short-circuit monitoring configurable

- Fault storage can be switched off
- Auto reset configurable
- Reset button
- Remote reset
- Monitoring of bimetals
- Short-circuit monitoring of the sensor circuit configurable
- 2 c/o contacts
- 2 LEDs for status indication

CM-MSS (4) + CM-MSS (5), 1-channel

- Short-circuit monitoring of the sensor circuit
- Wide supply voltage range: 24-240 V AC/DC
- Non-volatile fault storage selectable
- Reset and test button
- Remote reset
- Auto reset configurable
- Output contacts: 1 n/c and 1 n/o or 2 c/o contacts
- 2 LEDs for status indication

CM-MSS (6), 2-channel, single evaluation

- Short-circuit monitoring for the sensor circuits
- Wide supply voltage range: 24-240 V AC/DC
- 2 separate sensor circuits for monitoring of two motors or one motor with 2 sensor circuits (prewarning and final switch off)
- Reset button
- Auto reset configurable
- Output contacts: 2 x 1 c/o contact
- 3 LEDs for status indication

CM-MSS (7), 3 sensor circuits, accumulative evaluation

- Short-circuit monitoring for the sensor circuits
- Wide supply voltage range 24-240 V AC/DC
- Non-volatile fault storage configurable
- Remote reset
- Auto reset configurable
- Reset and test button
- Output contacts: 1 n/c and 1 n/o contact
- 4 LEDs for status indication

CM-MSN, 6 sensor circuits, accumulative evaluation

- Short-circuit monitoring of the sensor circuit
- Wide supply voltage range: 24-240 V AC/DC
- Non-volatile fault storage configurable
- Remote reset
- Auto reset configurable
- Reset and test button
- Output contacts: 1 n/c, 1 n/o contact
- 7 LEDs for status indication

accumulative evaluation = if any input exceeds the threshold, the output relay will trip

Thermistor motor protection relays

Operating controls

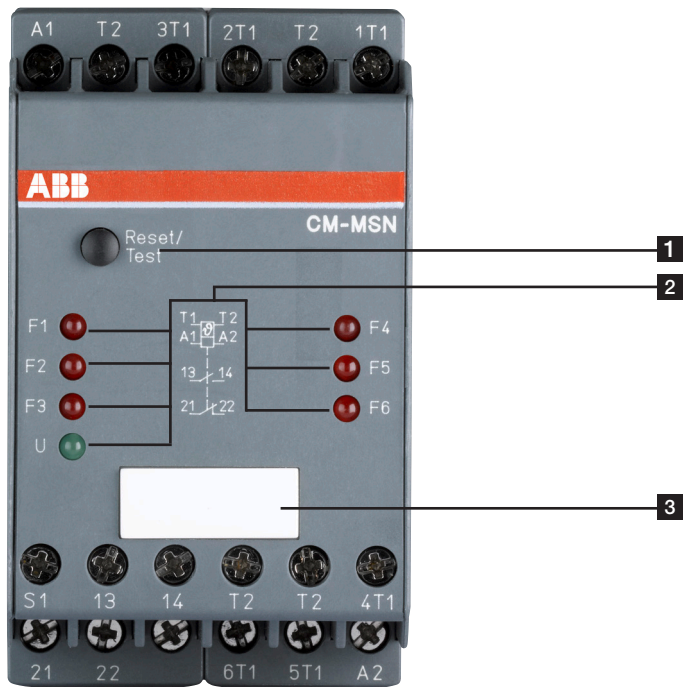

- 1** Reset / Test button
- 2** Indication of operational states
U: green LED – control supply voltage
F: red 1-6 LED – fault message
- 3** Marker label

Thermistor motor protection relays

Selection table thermistor motor protection relays

2

	Type	Order number
	CM-MSE	1SVR 550 805 R9300
		1SVR 550 800 R9300
		1SVR 550 801 R9300
	CM-MSS (1)	1SVR 430 800 R9100
		1SVR 430 800 R9100
	CM-MSS (2)	1SVR 430 811 R9300
		1SVR 430 811 R9300
		1SVR 430 811 R0300
		1SVR 430 811 R1300
	CM-MSS (3)	1SVR 430 710 R9300
		1SVR 430 711 R0300
		1SVR 430 711 R1300
		1SVR 430 711 R2300
	CM-MSS (4)	1SVR 430 720 R0400
	CM-MSS (5)	1SVR 430 720 R0300
	CM-MSS (6)	1SVR 430 710 R0200
	CM-MSS (7)	1SVR 430 720 R0500
	CM-MSN	1SVR 450 025 R0100
Function		
Number of sensor circuits		1 1 1 1 1 1 1 1 1 1 1 1 1 1 1 2 3 6
Wire break monitoring		■ ■ ■ ■ ■ ■ ■ ■ ■ ■ ■ ■ ■ ■ ■ ■ ■ ■ ■
Short-circuit detection ¹⁾		■ ■ ■ ■ ■ ■ ■ ■ ■ ■ ■ ■ ■ ■ ■ ■ ■ ■ ■
Non-volatile fault storage ²⁾		■ ■ ■ ■ ■ ■ ■ ■ ■ ■ ■ ■ ■ ■ ■ ■ ■ ■ ■
Operation / Reset		
Auto reset		■ ■ ■ ■ ■ ■ ■ ■ ■ ■ ■ ■ ■ ■ ■ ■ ■ ■ ■
Manual reset		■ ■ ■ ■ ■ ■ ■ ■ ■ ■ ■ ■ ■ ■ ■ ■ ■ ■ ■
Remote reset		■ ■ ■ ■ ■ ■ ■ ■ ■ ■ ■ ■ ■ ■ ■ ■ ■ ■ ■
Test button		■ ■ ■ ■ ■ ■ ■ ■ ■ ■ ■ ■ ■ ■ ■ ■ ■ ■ ■
Output contacts		
Operational principle	Closed-circuit principle	
1 n/o		■ ■ ■ ■ ■ ■ ■ ■ ■ ■ ■ ■ ■ ■ ■ ■ ■ ■ ■
1 c/o		■ ■ ■ ■ ■ ■ ■ ■ ■ ■ ■ ■ ■ ■ ■ ■ ■ ■ ■
2 c/o		■ ■ ■ ■ ■ ■ ■ ■ ■ ■ ■ ■ ■ ■ ■ ■ ■ ■ ■
1 n/o + 1 n/c		■ ■ ■ ■ ■ ■ ■ ■ ■ ■ ■ ■ ■ ■ ■ ■ ■ ■ ■
1 c/o per sensor circuit		■ ■ ■ ■ ■ ■ ■ ■ ■ ■ ■ ■ ■ ■ ■ ■ ■ ■ ■
1 n/o + 1 n/c accumulative evaluation		■ ■ ■ ■ ■ ■ ■ ■ ■ ■ ■ ■ ■ ■ ■ ■ ■ ■ ■
Width of housing		
22.5 mm		■ ■ ■ ■ ■ ■ ■ ■ ■ ■ ■ ■ ■ ■ ■ ■ ■ ■ ■
45 mm		■ ■ ■ ■ ■ ■ ■ ■ ■ ■ ■ ■ ■ ■ ■ ■ ■ ■ ■
Supply voltages		
24 V AC		■ ■ ■ ■ ■ ■ ■ ■ ■ ■ ■ ■ ■ ■ ■ ■ ■ ■ ■
24 V AC/DC		■ ■ ■ ■ ■ ■ ■ ■ ■ ■ ■ ■ ■ ■ ■ ■ ■ ■ ■
110-130 V AC		■ ■ ■ ■ ■ ■ ■ ■ ■ ■ ■ ■ ■ ■ ■ ■ ■ ■ ■
220-240 V AC		■ ■ ■ ■ ■ ■ ■ ■ ■ ■ ■ ■ ■ ■ ■ ■ ■ ■ ■
380-440 V AC		■ ■ ■ ■ ■ ■ ■ ■ ■ ■ ■ ■ ■ ■ ■ ■ ■ ■ ■
24-240 V AC/DC		■ ■ ■ ■ ■ ■ ■ ■ ■ ■ ■ ■ ■ ■ ■ ■ ■ ■ ■

¹⁾ For CM-MSS (3): configurable via terminals

²⁾ Auto reset without non-volatile fault storage configurable by permanent jumpering of connection terminals S1-T2 or S1/X1-S2/X2

Thermistor motor protection relays

Ordering details



CM-MSE



CM-MSS (5)



CM-MSN

Description

The thermistor motor protection relays CM-MSE, CM-MSS and CM-MSN are used to control motors equipped with PTC temperature sensors. The PTC temperature sensors are incorporated in the motor windings to measure the motor heating. This enables direct control and evaluation of various operating conditions. Depending on the products also ATEX approvals for use in hazardous areas are available.

ABB also offers PTC temperature sensors C011 (according to DIN 44081) which are suitable for embedding in motor windings.

Ordering details

Rated control supply voltage = measuring voltage	Type	Order code	Price	Weight (1 pce)
			1 pce	kg (lb)
24 V AC	CM-MSE	1SVR550805R9300		0.11 (0.24)
110-130 V AC		1SVR550800R9300		0.11 (0.24)
220-240 V AC		1SVR550801R9300		0.11 (0.24)
24 V AC/DC ¹⁾	CM-MSS (1)	1SVR430800R9100		0.15 (0.33)
220-240 V AC		1SVR430801R1100		0.15 (0.33)
24 V AC/DC ¹⁾	CM-MSS (2)	1SVR430810R9300		0.15 (0.33)
24 V AC		1SVR430811R9300		0.15 (0.33)
110-130 V AC		1SVR430811R0300		0.15 (0.33)
220-240 V AC	CM-MSS (3) ⁴⁾	1SVR430811R1300		0.15 (0.33)
24 V AC/DC ¹⁾		1SVR430710R9300		0.15 (0.33)
110-130 V AC		1SVR430711R0300		0.15 (0.33)
220-240 V AC	CM-MSS (4) ^{2) 4)}	1SVR430711R1300		0.15 (0.33)
380-440 V AC		1SVR430711R2300		0.15 (0.33)
24-240 V AC/DC	CM-MSS (5) ^{3) 4)}	1SVR430720R0400		0.15 (0.33)
	CM-MSS (6) ⁴⁾	1SVR430720R0300		0.15 (0.33)
	CM-MSS (7) ⁴⁾	1SVR430710R0200		0.15 (0.33)
	CM-MSS (7) ⁴⁾	1SVR430720R0500		0.15 (0.33)
	CM-MSN ⁴⁾	1SVR450025R0100		0.23 (0.51)

¹⁾ Not electrically isolated

²⁾ CM-MSS (4): 1-channel 1 n/c, 1 n/o

³⁾ CM-MSS (5): 1-channel 2 c/o

⁴⁾ Ⓜ

Thermistor motor protection relays

Ordering details - PTC temperature sensors C011

2



1SVC 110 000 F0531

Temperature sensor characteristics

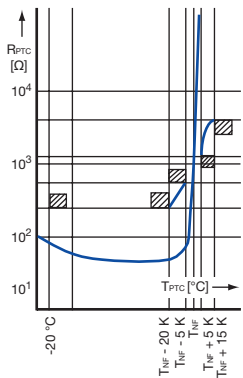

2CDC 252 068 F0208

Description

The PTC temperature sensors (temperature-dependent with positive temperature coefficient) are selected by the manufacturer of the motor depending on:

- the motor insulation class according to IEC/EN 60034-11,
- the special characteristics of the motor, such as the conductor cross-section of the windings, the permissible overload factor etc.
- special conditions prescribed by the user, such as the permissible ambient temperature, risks resulting from locked rotor, extent of permitted overload etc.

One temperature sensor must be embedded in each phase winding. For instance, in case of three-phase squirrel cage motors, three sensors are embedded in the stator windings. For pole-changing motors with one winding (Dahlander connection), 3 sensors are also sufficient. Pole-changing motors with two windings, however, require The sensors are suitable for embedding in motor windings with rated operating voltages of up to 600 V AC. Conductor length: 500 mm per sensor. A 14 V varistor can be connected in parallel to protect the sensors from overvoltage. Due to their characteristics, the thermistor motor protection relays can also be used with PTC temperature sensors of other manufacturers which comply with DIN 44 081 and DIN 44 082 6 sensors.

If an additional warning is required before the motor is switched off, separate sensors for a correspondingly lower temperature must be embedded in the winding. They have to be connected to a second control unit.

Ordering details

Rated response temperature T_{NF}	Color coding	Type	Order code	Price 1 pce	Weight (1 pce) kg (lb)
70 °C	white-brown	C011-70 ¹⁾	GHC0110003R0001		0.02 (0.044)
80 °C	white-white	C011-80 ¹⁾	GHC0110003R0002		0.02 (0.044)
90 °C	green-green	C011-90 ¹⁾	GHC0110003R0003		0.02 (0.044)
100 °C	red-red	C011-100 ¹⁾	GHC0110003R0004		0.02 (0.044)
110 °C	brown-brown	C011-110 ¹⁾	GHC0110003R0005		0.02 (0.044)
120 °C	gray-gray	C011-120 ¹⁾	GHC0110003R0006		0.02 (0.044)
130 °C	blue-blue	C011-130 ¹⁾	GHC0110003R0007		0.02 (0.044)
140 °C	white-blue	C011-140 ¹⁾	GHC0110003R0011		0.02 (0.044)
150 °C	black-black	C011-150 ¹⁾	GHC0110003R0008		0.02 (0.044)
160 °C	blue-red	C011-160 ¹⁾	GHC0110003R0009		0.02 (0.044)
170 °C	white-green	C011-170 ¹⁾	GHC0110003R0010		0.02 (0.044)
150 °C	black-black	C011-3-150 ²⁾	GHC0110033R0008		0.05 (0.11)

¹⁾ Temperature sensor C011, standard version acc. to DIN 44081

²⁾ Triple temperature sensor C011-3

Technical data

Characteristic data	Sensor type C011
Cold-state resistance	50 -100 Ω at 25 °C
Warm-state resistance ± 5 up to 6 K of rated response temperature T_{NF}	10 000 Ω
Thermal time constant, sensor open ¹⁾	< 5 s
Permitted ambient temperature	+180 °C

Rated response temperature \pm tolerance $T_{NF} \pm \Delta T_{NF}$	PTC resistance R from -20 °C to $T_{NF} - 20$ K	PTC resistance R ²⁾ at PTC temperatures of:		
		$T_{NF} - \Delta T_{NF}$ (UPTC ≤ 2.5 V)	$T_{NF} + \Delta T_{NF}$ (UPTC ≤ 2.5 V)	$T_{NF} + 15$ K (UPTC ≤ 7.5 V)
70 ± 5 °C	$\leq 100 \Omega$	$\leq 570 \Omega$	$\geq 570 \Omega$	-
80 ± 5 °C				
90 ± 5 °C				
100 ± 5 °C				
110 ± 5 °C				
120 ± 5 °C				
130 ± 5 °C				
140 ± 5 °C				
150 ± 5 °C				
160 ± 5 °C				
170 ± 7 °C		$\leq 570 \Omega$	$\geq 570 \Omega$	-

¹⁾ Not embedded in windings.

²⁾ For triple temperature sensor take values x 3.

Thermistor motor protection relays

Technical data

Type		CM-MSE	CM-MSS	CM-MSN
Input circuit				
Rated control supply voltage U_s power consumption	A1-A2	24 V AC approx. 1.5 VA		
	A1-A2	24 V AC/DC approx. 1.1 VA / 0.6 W		
	A1-A2	110-130 V AC approx. 1.5 VA		
	A1-A2	220-240 V AC approx. 1.5 VA		
	A1-A2	380-440 V AC approx. 1.7 VA		
Rated control supply voltage U_s tolerance	A1-A2	24-240 V AC/DC approx. 1.4-1.7 W / approx. 3.5-5.7 VA		
Rated frequency		AC: 50-60 Hz / 24-240 V AC/DC versions: 15-400 Hz		
Duty time		100 %		
Measuring circuit				
Monitoring function		T1-T2	T1-T2/T2x, 1T1...6T1-T2	1T1...6T1-T2
Number of sensor circuits		1	1, 2 oder 3 (see order details)	6
Short-circuit monitoring		-	see ordering details	yes
Non-volatile fault storage		-	see ordering details	configurable
Test function		-	see ordering details	yes
Sensor circuit				
Temperature threshold (relay de-energizes)		2.7-3.7 k Ω	CM-MSS (1+2): 3050 \pm 550 Ω CM-MSS (3-7): 3.6 k Ω \pm 5 %	3.6 k Ω \pm 5 %
Temperature hysteresis (relay energizes)		1.7-2.3 k Ω	CM-MSS (1+2): 1900 \pm 400 Ω CM-MSS (3-7): 1.6 k Ω \pm 5 %	1.6 k Ω \pm 5 %
Short-circuit threshold (relay de-energizes)		<18 Ω		
Short-circuit hysteresis (relay energizes)		>45 Ω		
Maximum total resistance of sensors connected in series (cold state)		\leq 1.5 k Ω		
Maximum sensor cable length for short-circuit detection		2 x 100 m at 0.75 mm ² , 2 x 400 m at 2.5 mm ²		
Response time		<100 ms		
Control circuit for storage and hysteresis function				
Remote reset	S1-T2 or S1/X1-S2/X2	-	n/o contact	
Maximum no-load voltage		-	approx. 25 V, 24-240 V; AC/DC versions: 5.5 V	
Maximum cable length		-	\leq 50 m, 100-200 m if shielded	
Indication of operational states				
Control supply voltage	U: green LED	-	[]: control supply voltage applied	
Fault indication	F: red LED	-	[]: output relay de-energized	
Output circuits				
		13-14	11-12/14, 21-22/24, 13-14, 21-22	13-14, 21-22
Kind of output		1 n/o contact	CM-MSS (1): 1 c/o contact CM-MSS (2,3,5): 2 c/o contacts CM-MSS (4, 7): 1 n/o + 1 n/c CM-MSS (6): 2x1 c/o contact	1 n/o + 1 n/c contact
Operational principle		closed-circuit principle (output relay de-energizes if the measured value exceeds/drops below the adjusted threshold)		
Contact material		AgCdO	CM-MSS (1+2+6): AgCdO CM-MSS (3+4+5+7): AgNi	AgNi
Rated voltage (VDE 0110, IEC 664-1, IEC 60947-1)		250 V		
Maximum switching voltage		250 V		
Rated operational current I_o (IEC/EN 60947-5-1)	AC12 (resistive) at 230 V	4 A		
	AC15 (inductive) at 230 V	3 A		
	DC12 (resistive) at 24 V	4 A		
	DC13 (resistive) at 24 V	2 A (1.5 A - n/c contact ¹⁾)		
AC rating (UL 508)	Utilization category (Control Circuit Rating Code)			
	max. rated operational voltage	300 V AC		
	max. continuous thermal current at B300	5 A		
	max. making/breaking apparent power at B300	3600/360 VA		
Mechanical lifetime		30 (10 ¹¹) x 10 ⁶ switching cycles		
Electrical lifetime (AC12, 230 V, 4 A)		0.1 x 10 ⁶ switching cycles		
Max. fuse rating to achieve short-circuit protection	n/c contact	10 A fast-acting	4 A (10 A ¹⁾) fast-acting	10 A fast-acting
	n/o contact	10 A fast-acting	6 A (10 A ¹⁾) fast-acting	10 A fast-acting
General data				
Dimensions (W x H x D)		22.5 x 78 x 78.5 mm (0.89 x 3.07 x 3.09 in)	22.5 x 78 x 100 mm (0.89 x 3.07 x 3.94 in)	45 x 78 x 100 mm (1.77 x 3.07 x 3.94 in)
Weight		approx. 0.11 kg (0.24 lb)	approx. 0.15 kg (0.33 lb)	approx. 0.23 kg (0.51 lb)
Mounting position		any		
Degree of protection	housing / terminals	IP50 / IP20		
Ambient temperature range	operation	-20...+60 °C		
	storage	-40...+85 °C		
Mounting		DIN rail (IEC/EN 60715)		

¹⁾ 1SVR 430 710 R 0200, 1SVR 430 8xx R xxxx

Thermistor motor protection relays

Technical data,

2

Type		CM-MSE	CM-MSS	CM-MSN
Electrical connection				
Wire size	fine strand with wire end ferrule	2 x 1.5 mm ² (2 x 16 AWG)	2 x 2.5 mm ² (2 x 14 AWG)	
	fine strand without wire end ferrule	2 x 0.75-1.5 mm ² (2 x 18-16 AWG)	2 x 0.75-2.5 mm ² (2 x 18-14 AWG)	
	rigid	2 x 1-1.5 mm ² (2 x 18-16 AWG)	2 x 0.5-4 mm ² (2 x 20-12 AWG)	
Stripping length		2 x 0.75-1.5 mm ² (2 x 18-16 AWG)	2 x 0.5-4 mm ² (2 x 20-12 AWG)	
Tightening torque		10 mm (0.39 inch)	7 mm (0.28 inch)	
Standards				
Product standard		IEC 255-6, EN 60255-6		
Low Voltage Directive		2006/95/EC		
EMC Directive		2004/108/EC, 91/263/EEC, 92/31/EEC, 93/68/EEC, 93/67/EEC		
Electromagnetic compatibility		EN 61000-6-2, EN 61000-6-4		
electrostatic discharge	IEC/EN 61000-4-2	Level 3 (6 kV / 8 kV)		
radiated, radio-frequency, electromagnetic field	IEC/EN 61000-4-3	Level 3 (10 V/m)		
electrical fast transient /burst	IEC/EN 61000-4-4	Level 3 (2 kV / 5 kHz)		
surge	IEC/EN 61000-4-5	Level 3/4 (1/2 kV)		
conducted disturbances, induced by radio-frequency fields	IEC/EN 61000-4-6	Level 3 (10 V)		
Operational reliability (IEC 68-2-6)		6 g	4 g	5 g
Resistance to vibration (IEC 68-2-6)		10 g	6 g	10 g
Environmental testing (IEC 68-2-30)		24 h cycle time, 55 °C, 93 % rel., 96 h		
Isolation data				
Rated voltage between supply, measuring and output circuit		250 V		
Rated impulse withstand voltage between all isolated circuits		4 kV / 1.2 - 50 μs		
Test voltage between all isolated circuits		2.5 kV, 50 Hz, 1 min.		
Pollution degree		3		
Overvoltage category		III		

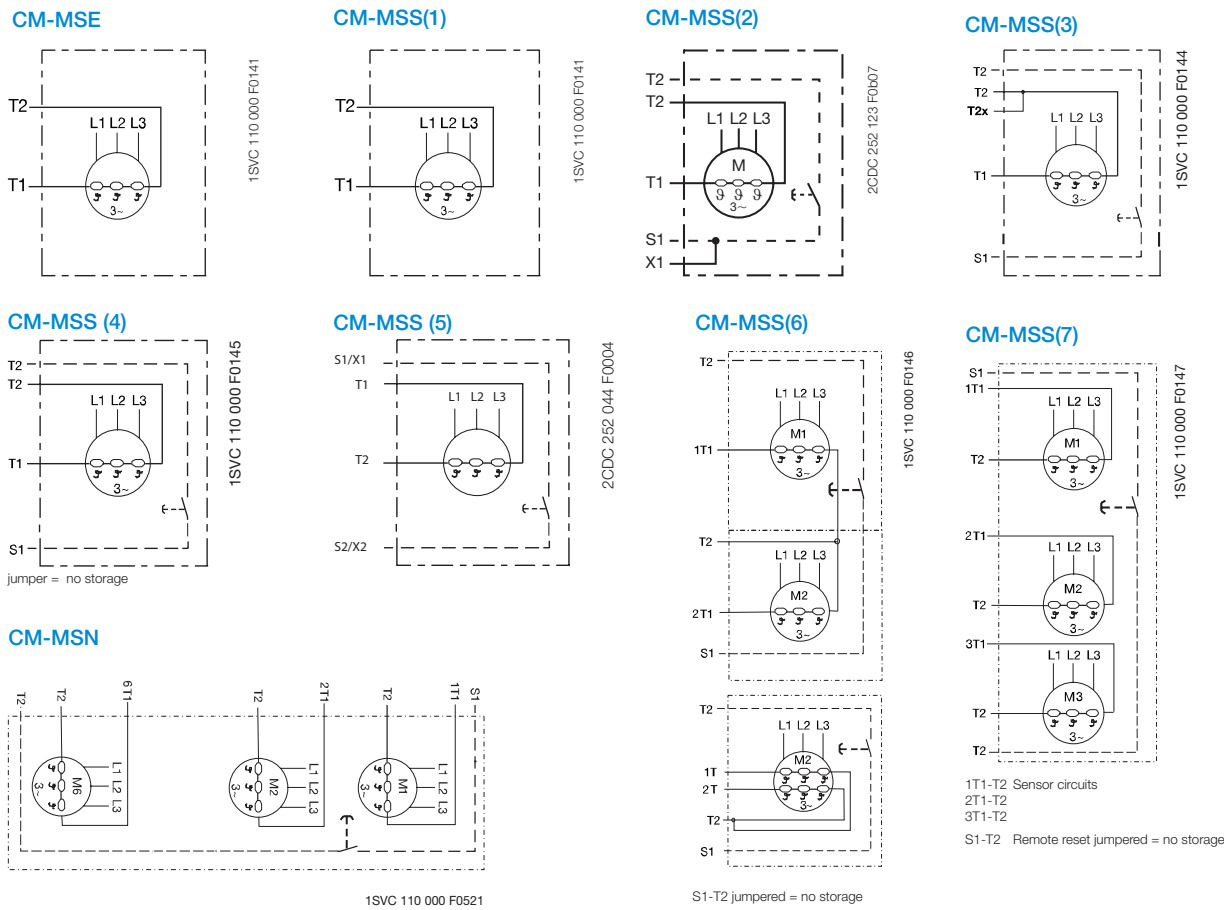

Thermistor motor protection relays

Connection diagrams

CM-MSE

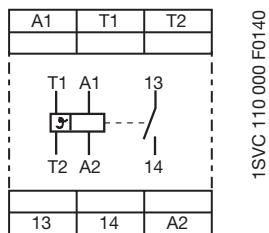

1SVC 110 000 F0140

A1-A2 Rated control supply voltage
T1-T2 Sensor circuit
13-14 Output contact - Closed-circuit principle

CM-MSS(1)

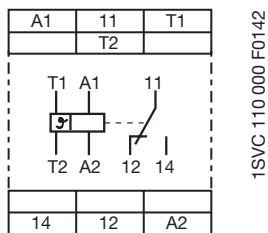

1SVC 110 000 F0142

A1-A2 Rated control supply voltage
T1-T2 Sensor circuit
11-12/14 Output contact - Closed-circuit principle

CM-MSS(2)

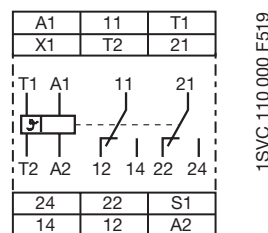

1SVC 110 000 F519

A1-A2 Rated control supply voltage
T1-T2 Sensor circuit
S1-T2 Remote reset X1-T2 jumper = no storage
11-12/14 Output contacts -
21-22/24 Closed-circuit principle

CM-MSS(3)

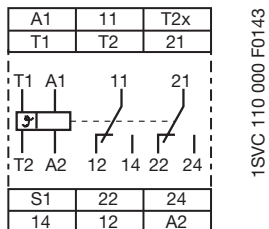

1SVC 110 000 F0143

A1-A2 Rated control supply voltage
S1-T2 Remote reset jumper = without storage
T1-T2x measuring circuit without short-circuit monitoring
T1-T2 measuring circuit with short-circuit monitoring
11-12/14 Output contacts -
21-22/24 Closed-circuit principle

CM-MSS (4)

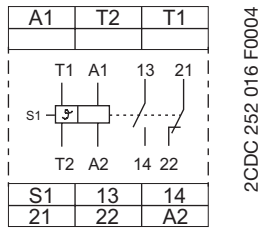

2CDC 252 016 F0004

A1-A2 Rated control supply voltage
T1-T2 Sensor circuit
S1-T2 Remote reset
13-14 Output contacts -
21-22 Closed-circuit principle

CM-MSS (5)

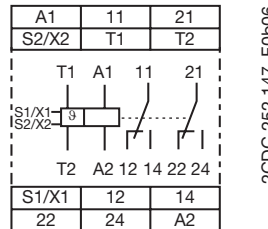

2CDC 252 147 F0606

A1-A2 Rated control supply voltage
T1-T2 Sensor circuit
S1/X1-S2/X2 Reset
11-12/14 Output contacts -
21-22/24 Closed-circuit principle

CM-MSS(6)

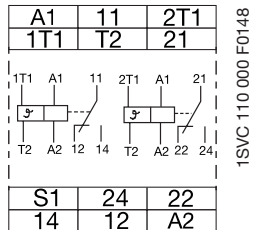

1SVC 110 000 F0148

A1-A2 Rated control supply voltage
11-12/14, 21-22/24 Output contacts -
Closed-circuit principle
1T1-T2 Sensor circuit
2T1-T2

CM-MSS(7)

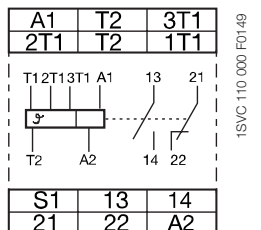

1SVC 110 000 F0149

A1-A2 Rated control supply voltage
13-14 Output contacts -
21-22 Closed-circuit principle

CM-MSN

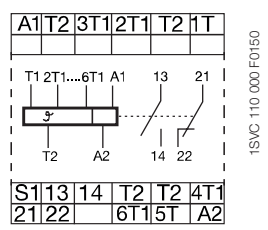

1SVC 110 000 F0150

A1-A2 Rated control supply voltage
13-14 Output contacts -
21-22 Closed-circuit principle

Temperature monitoring relays

Product group picture

2



Temperature monitoring relays

Table of contents

Temperature monitoring relays	
Product group picture	99
Table of contents	100
Benefits and advantages, Applications	101
Operating controls	102
Selection	103
Ordering details	104
Function diagrams	105
Overview, functional description and diagrams	106
Connection diagrams, Resistance thermometer sensors	107
Technical data - CM-TCS.xx	108
Technical data - C51x	110

Temperature monitoring relays

Benefits and advantages, Applications

Overview

The temperature monitoring relays can be used for temperature measurement in solid, liquid and gaseous media. The temperature is acquired by the sensor in the medium, evaluated by the device and monitored to determine whether it is within an operating range (range monitoring function) or has exceeded or fallen below a threshold.

2

Characteristics CM-TCS

- Adjustable sensor type: PT100
- Functionality like overtemperature monitoring, undertemperature monitoring, temperature window monitoring configurable
- All configurations and adjustments by front-face operating elements
- Precise adjustment with direct reading scales
- One or two threshold values
- Hysteresis 2...20 % adjustable
- Operating temperature range -40...+60 °C
- 1 x 2 c/o or 2 x 1 c/o configurable
- Open- or closed-circuit principle configurable
- Short-circuit monitoring and interrupted wire detection
- 22.5 mm (0.89 in) width
- LEDs for status indication

Functional description

The temperature monitoring relays CM-TCS monitor overtemperature, undertemperature, or temperatures between two threshold values (window monitoring) with PT100 sensor. As soon as the temperature falls below or exceeds the threshold value the output relays change their positions according to the configured functionality and the front-face LEDs display the current status. Regardless of the selected configuration, the device is monitoring its measuring circuit for interrupted wires or short-circuits.

Characteristics C512 + C513

- Adjustable sensor types: PT100, PT1000, KTY83, KTY84, NTC-B57227-K333-A1
- Measuring principle for 2-wire and 3-wire sensors
- Temperature monitor for 1-3 sensor circuits
- Adjustable over-, undertemperature monitoring or range monitoring function
- 2 thresholds
- Hysteresis for both thresholds (1-99 Kelvin)
- Adjustable time delay from 0-999 s affects to both thresholds
- Storage function selectable via external signal (Y1-Y2)
- Non volatile storage of parameter settings
- 1 n/o (for wire-break and short-circuit detection) and 2 c/o
- Multifunctional digital display
- 3 LEDs for status indication
- Open- or closed-circuit principle selectable
- 45 mm wide housing with 24 terminals

C512

- Temperature monitor for 1 sensor circuit

C513

- Temperature monitor for 1-3 sensor circuits
- In the 3-sensor version the status of the single sensors is displayed if the temperature exceeds or falls below the threshold. This way it can be easily determined which one of the connected sensors has exceeded or dropped below either one or both threshold values.

Temperature monitoring relays

Operating controls

S-Range Housing

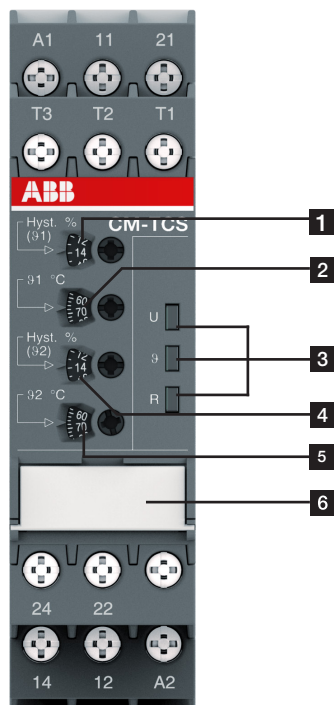

- 1** Adjustment of the hysteresis for threshold value ϑ_1
- 2** Adjustment of the threshold value ϑ_1
- 3** Indication of operational states
 U: green LED – status indication of control supply voltage
 ϑ : red LED – fault message, state of measuring input
 R: yellow LED – status indication of the output relays
- 4** Adjustment of the hysteresis for threshold value ϑ_2
- 5** Adjustment of the threshold value ϑ_2
- 6** DIP switch functions / marker label (on page 2/108)
 - Overtemperature monitoring
 - Undertemperature monitoring
 - Temperature window monitoring activated
 - Temperature window monitoring de-activated
 - Closed-circuit principle
 - Open-circuit principle
 - 2 x 1 c/o (SPDT) contact
 - 1 x 2 c/o (SPDT) contacts

Temperature monitoring relays

Selection

2

	New range																		
	Type	Order number																	
	CM-TCS.21S	1SVR 730 740 R9100																	
	CM-TCS.21P	1SVR 740 740 R9100																	
	CM-TCS.11S	1SVR 730 740 R0100																	
	CM-TCS.11P	1SVR 740 740 R0100																	
	CM-TCS.22S	1SVR 730 740 R9200																	
	CM-TCS.22P	1SVR 740 740 R9200																	
	CM-TCS.12S	1SVR 730 740 R0200																	
	CM-TCS.12P	1SVR 740 740 R0200																	
	CM-TCS.23S	1SVR 730 740 R9300																	
	CM-TCS.23P	1SVR 740 740 R9300																	
	CM-TCS.13S	1SVR 730 740 R0300																	
	CM-TCS.13P	1SVR 740 740 R0300																	
	C512-24	1SAR 700 016 R0005																	
	C512-W	1SAR 700 016 R0010																	
	C513-W	1SAR 700 016 R0010																	
Rated control supply voltage U_s																			
24 V AC/DC			■	■															
24-240 V AC/DC					■	■													
Technology																			
analogue			■	■	■	■	■	■	■	■	■	■	■	■					
digital																		■	■
Sensor circuits (2 or 3 wire)																			
number of temperature sensors			1	1	1	1	1	1	1	1	1	1	1	1				1	1
number of thresholds			2	2	2	2	2	2	2	2	2	2	2	2				2	2
Sensor type																			
PT100			■	■	■	■	■	■	■	■	■	■	■	■				■	■
PT100, KTY83, KTY84, NTC, PT1000																		■	■
Measuring temperature range																			
-50...+50 °C			■	■	■	■													
0...+100 °C							■	■	■	■									
0...+200 °C											■	■	■	■					
-50...+500 °C																		■	■
Monitoring function																			
overtemperature			■	■	■	■	■	■	■	■	■	■	■	■				■	■
undertemperature			■	■	■	■	■	■	■	■	■	■	■	■				■	■
window temperature			■	■	■	■	■	■	■	■	■	■	■	■				■	■
Operating principle																			
open or closed principle			■	■	■	■	■	■	■	■	■	■	■	■				■	■
Output contacts																			
n/o																		1	1
c/o			2	2	2	2	2	2	2	2	2	2	2	2				2	2

Temperature monitoring relays

Ordering details

Description

Acquisition, messaging and regulation of temperatures of solid, liquid and gaseous media in processes and machines via PT100, PT1000, KTY83, KTY84 or NTC sensors. ABB offers different temperature monitoring relays to meet the needs of your application:



CM-TCS

Ordering details - Temperature monitoring relays PT100 sensors, 2 or 3 wire connection, 2 thresholds adjustable

Rated control supply voltage	Measuring range	Type	Order code	Price	Weight (1 pce)
				1 pce	kg (lb)
24-240 V AC/DC	-50...+50 °C	CM-TCS.11S	1SVR730740R0100		0.151 (0.333)
		CM-TCS.11P	1SVR740740R0100		0.140 (0.309)
	0...+100 °C	CM-TCS.12S	1SVR730740R0200		0.151 (0.333)
		CM-TCS.12P	1SVR740740R0200		0.140 (0.309)
	0...+200 °C	CM-TCS.13S	1SVR730740R0300		0.151 (0.333)
		CM-TCS.13P	1SVR740740R0300		0.140 (0.309)
24 V AC/DC	-50...+50 °C	CM-TCS.21S	1SVR730740R9100		0.138 (0.304)
		CM-TCS.21P	1SVR740740R9100		0.127 (0.280)
	0...+100 °C	CM-TCS.22S	1SVR730740R9200		0.138 (0.304)
		CM-TCS.22P	1SVR740740R9200		0.127 (0.280)
	0...+200 °C	CM-TCS.23S	1SVR730740R9300		0.138 (0.304)
		CM-TCS.23P	1SVR740740R9300		0.127 (0.280)



C512, C513

Ordering details - Temperature monitoring relays C51x range with display and digital setup

Rated control supply voltage	Measuring range	Type ²⁾	Order code	Price	Weight (1 pce)
				1 pce	kg (lb)
24 V AC/DC		C512-24	1SAR700100R0005		0.32 (0.71)
24-240 V AC/DC	-50...+500 °C ¹⁾	C512-W	1SAR700100R0010		0.33 (0.73)
24-240 V AC/DC		C513-W	1SAR700110R0010		0.34 (0.75)

¹⁾ The measuring range depends on the used sensor type:

- PT100: -50...+500 °C
- PT1000: -50...+500 °C
- NTC: +80...+160 °C

(Typ Siemens Matsushita B57272-A333-A1 - 100 °C: 1,8 kΩ, 25 °C: 32,762 kΩ)

- KTY84: -40...+300 °C
- KTY83: -50...+175 °C

³⁾ PT100 sensors, PT1000, KTY83, KTY84, NTC-B57227-K333-A1, 2 or 3 wire connection, 2 thresholds, multifunctional display Open- or closed-circuit principle adjustable, 1 n/o, 2 c/o contacts

Ordering details - Replaceable cover marking for digital devices

Use for	Language	Type	Order code	Price	Weight (1 pce)
				5 pces	kg (lb)
C512	German	C512-D	1SVR700101R0100		
C512	English	C512-E	1SVR700102R0100		
C513	German	C513-D	1SVR700111R0100		
C513	English	C513-E	1SVR700112R0100		

Temperature monitoring relays

Function diagrams

CM-TCS - Overtemperature monitoring, 1 x 2 c/o contacts [\[12-04\]](#)

With this configuration, settings via 92 have no influence on the operating function (92 disabled).

Open-circuit principle:

If the measured value is correct, the output relays remain de-energized when control supply voltage is applied. If the measured value exceeds the adjusted threshold value 91, the output relays energize. If the measured value drops again below the adjusted threshold value 91 minus the adjusted hysteresis, the output relays de-energize.

Closed-circuit principle:

The behavior is inverse to the one with open-circuit principle.

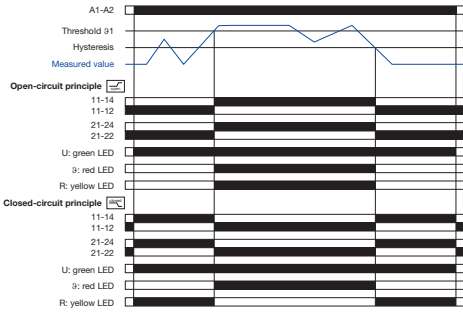

2CDC 252 006 F0209

Undertemperature monitoring, 1 x 2 c/o contacts [\[12-04\]](#)

With this configuration, settings via 91 have no influence on the operating function (91 disabled).

Open-circuit principle:

If the measured value is correct, the output relays remain de-energized when control supply voltage is applied. If the measured value drops below the adjusted threshold value 92, the output relays energize. If the measured value exceeds again the adjusted threshold value 92 plus the adjusted hysteresis, the output relays de-energize.

Closed-circuit principle:

The behavior is inverse to the one with open-circuit principle.

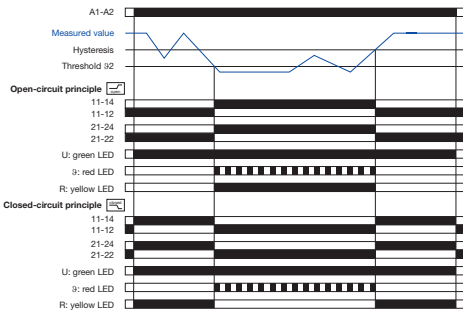

2CDC 252 010 F0209

Temperature window monitoring, 1 x 2 c/o contacts [\[12-04\]](#)

Open-circuit principle:

If the measured value is correct, the output relays remain de-energized when control supply voltage is applied. If the measured value exceeds the adjusted threshold value 91 or drops below the adjusted threshold value 92, the output relays energize. If the measured value drops again below the adjusted threshold value t , minus the adjusted hysteresis or exceeds again the adjusted threshold value 92 plus the adjusted hysteresis, the output relays de-energize.

Closed-circuit principle:

The behavior is inverse to the one with open-circuit principle.

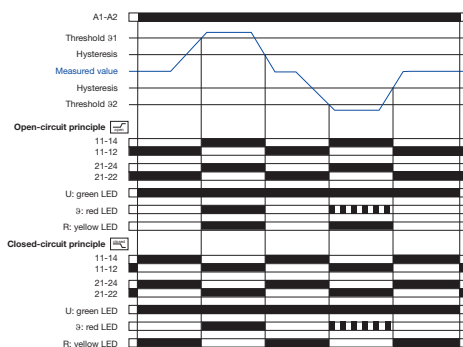

2CDC 252 012 F0209

Overtemperature monitoring, 2 x 1 c/o contact [\[01-08\]](#)

Open-circuit principle:

If the measured value is correct, the output relays remain de-energized when control supply voltage is applied. If the measured value exceeds the adjusted threshold value 92, output relay R2 (prewarning) energizes. If the measured value exceeds the adjusted threshold value 91, output relay R1 (final switch-off) energizes.

If the measured value drops again below the adjusted threshold value 91 minus the adjusted hysteresis, output relay R1 (final switch-off) de-energizes. If the measured value drops below the adjusted threshold value 92 minus the adjusted hysteresis, output relay R2 (prewarning) de-energizes.

Closed-circuit principle:

The behavior is inverse to the one with open-circuit principle.

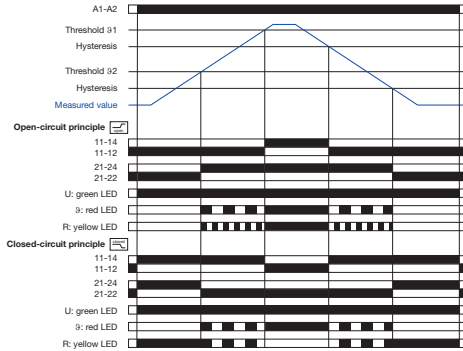

2CDC 252 008 F0209

Undertemperature monitoring, 2 x 1 c/o contact [\[01-08\]](#)

Open-circuit principle:

If the measured value is correct, the output relays remain de-energized when control supply voltage is applied. If the measured value drops below the adjusted threshold value 91, output relay R1 (prewarning) energizes. If the measured value drops below the adjusted threshold value 92, output relay R2 (final switch-off) energizes.

If the measured value exceeds again the adjusted threshold value 92 plus the adjusted hysteresis, output relay R2 (final switch-off) de-energizes. If the measured value exceeds the adjusted threshold value 91 plus the adjusted hysteresis, output relay R1 (prewarning) de-energizes.

Closed-circuit principle:

The behavior is inverse to the one with open-circuit principle.

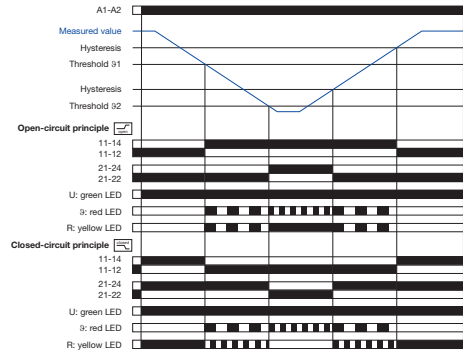

2CDC 252 011 F0209

Temperature window monitoring, 2 x 1 c/o contact [\[01-08\]](#)

Open-circuit principle:

If the measured value is correct, the output relays remain de-energized when control supply voltage is applied.

If the measured value exceeds the adjusted threshold value 91 or drops below the adjusted threshold value 92, output relay R1 (> 91) or R2 (< 92) respectively energizes.

If the measured value drops again below the adjusted threshold value 91 minus the adjusted hysteresis or exceeds again the adjusted threshold value 92 plus the adjusted hysteresis, output relay R1 (> 91) or R2 (< 92) respectively de-energizes.

Closed-circuit principle:

The behavior is inverse to the one with open-circuit principle.

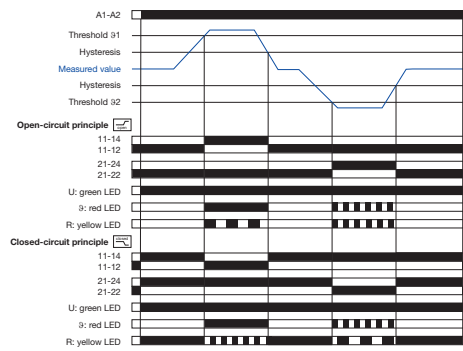

2CDC 252 013 F0209

Temperature monitoring relays

Overview, Functional description and diagrams

Functional description

Digital tripping devices

Once the temperature has reached the set threshold of ν_1 , output relay K1 changes its switching state after the set time delay t has elapsed (K2 reacts in the same way for ν_2).

Characteristic curves of resistance sensors

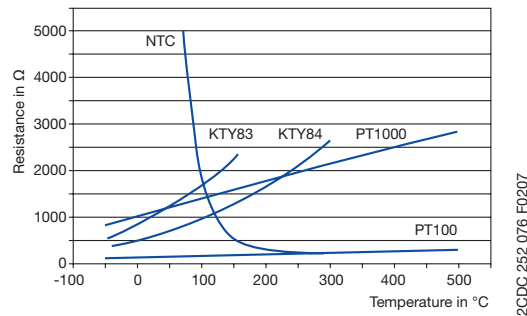

DIP switches CM-TCS

Position	4	3	2	1
ON ↑	2x1 c/o	closed	←	↘
OFF	1x2 c/o	open	⊗	↗

Function diagrams

Overtemperature - C512/C513

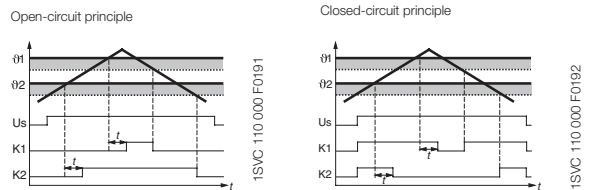

Undertemperature - C512/C513

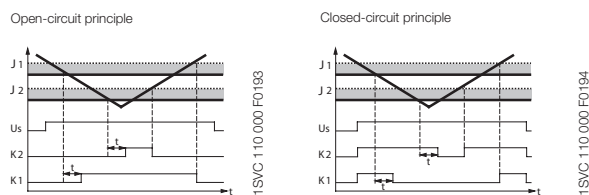

Range monitoring - C512/C513

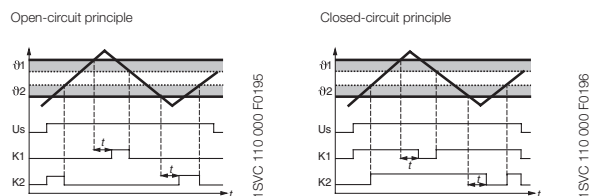

Function principle with storage function - C512/C513

using overtemperature with closed-circuit principle as an example

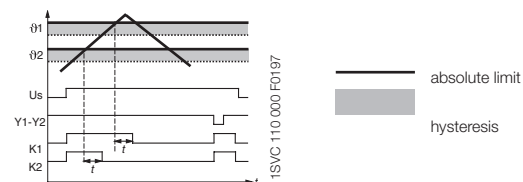

	ON	OFF (default)
DIP switch 1 Monitoring principle	Overtemperature monitoring <input checked="" type="checkbox"/> If overtemperature monitoring is selected, the CM-TCS recognizes temperatures above the selected threshold and trips the output relay according to the selected operating principle.	Undertemperature monitoring <input checked="" type="checkbox"/> If undertemperature monitoring is selected, the CM-TCS recognizes temperatures below the selected threshold and trips the output relay according to the selected operating principle.
DIP switch 2 Temperature window monitoring	Temperature window monitoring activated <input checked="" type="checkbox"/> If temperature window monitoring is selected, the CM-TCS monitors over- and undertemperature. If temperature window monitoring is activated, DIP switch 1 is disabled.	Temperature window monitoring de-activated <input checked="" type="checkbox"/> Temperature window monitoring is de-selected.
DIP switch 3 Operating principle of the output relays	Closed-circuit principle <input checked="" type="checkbox"/> If closed-circuit principle is selected, the output relays are energized. They de-energize if a fault is occurring.	Open-circuit principle <input checked="" type="checkbox"/> If open-circuit principle is selected, the output relays are deenergized. They energize if a fault is occurring.
DIP switch 4 2 x 1 c/o contact, 1 x 2 c/o contacts	2 x 1 c/o (SPDT) contact <input checked="" type="checkbox"/> If operating principle 2 x 1 c/o contact is selected, the output relay R1 (11-12/14) reacts to threshold value t_1 and the output relay R2 (21-22/24) reacts to threshold value t_2 .	1 x 2 c/o (SPDT) contacts <input checked="" type="checkbox"/> If operating principle 1 x 2 c/o contacts is selected, both output relays R1 (11-12/14) and R2 (21-22/24) react synchronously to one threshold value. Overtemperature monitoring: Settings of the threshold value t_2 have no effect on the operation. Undertemperature monitoring: Settings of the threshold values t_2 have no effect on the operation.

Temperature monitoring relays

Connection diagrams, Resistance thermometer sensors

Connection diagrams

2

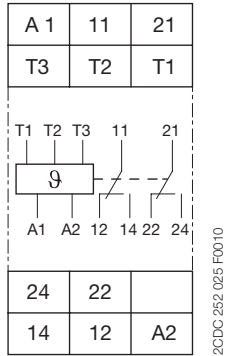

CM-TCS

- A1-A2 Control supply voltage
- 11-12/14 Output relay R1
- 21-22/24 Output relay R2
- T1, T2, T3 Measuring input, connection PT100

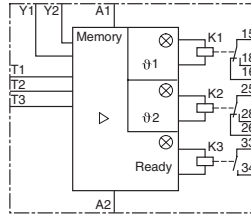

C512

- A1-A2 Rated control supply voltage
- 15-16/18 Output contacts
- 25-26/28
- 33-34
- T1-T3 Sensor connection
- Y1-Y2 Connection for storage bridge

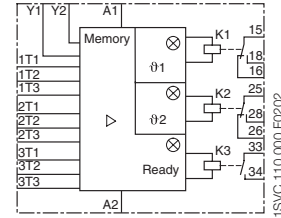

C513

- A1-A2 Rated control supply voltage
- 15-16/18 Output contacts
- 25-26/28
- 33-34
- 1T1-1T3 Sensor connection 1
- 2T1-2T3 Sensor connection 2
- 3T1-3T3 Sensor connection 3
- Y1-Y2 Connection for storage bridge

Connection of resistance thermometer sensors

2-wire measurement

When using 2-wire temperature sensors the sensor resistance and the wire resistance are added together. The resulting systematic errors must be taken into account when adjusting the tripping device.

A jumper must be connected between the terminals T2 and T3.

The following table can be used for PT100 sensors to determine the temperature errors caused by the line length.

When using resistance sensors with two-wire connection a bridge must be inserted between terminals T2 and T3.

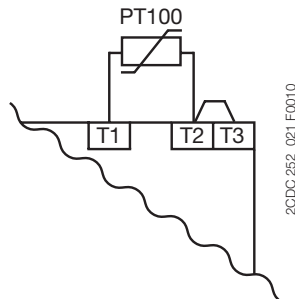

3-wire measurement

To minimize the influence of the wire resistance, a three-wire connection is usually used. By means of the additional wire two measuring circuits are created. One of these two circuits is used for reference. This way, the tripping device can calculate and take into account the wire resistance automatically.

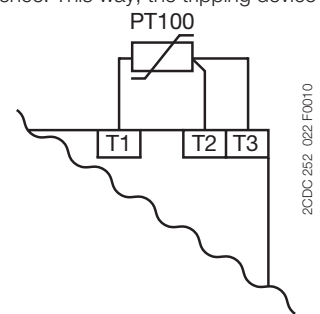

Error caused by the line

The error resulting from the line resistance amounts to approx. 2.5 Kelvin/Ohm. If the resistance of the line is not known and it is not possible to measure it, the error caused by the line can be estimated using the following table.

Temperature error

(depending on the line length and conductor cross section for PT100 sensors at an ambient temperature of 20 °C, in K)

Line length in m	Wire size mm ²			
	0.50	0.75	1	1.5
0	0.0	0.0	0.0	0.0
10	1.8	1.2	0.9	0.6
25	4.5	3.0	2.3	1.5
50	9.0	6.0	4.5	3.0
75	13.6	9.0	6.8	4.5
100	18.1	12.1	9.0	6.0
200	36.3	24.2	18.1	12.1
500	91.6	60.8	45.5	30.2

Electrical isolation

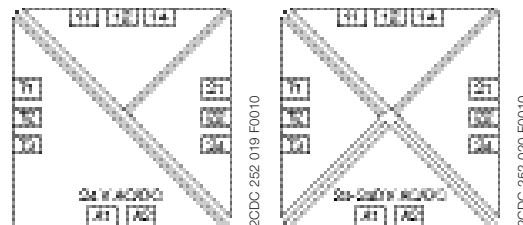

- Electrical isolation
- Protective separation acc. to IEC/EN 61140; EN 50178

Temperature monitoring relays

Technical data - CM-TCS.xx

Type		CM-TCS.11/12/13	CM-TCS.21/22/23
Input circuit			
Rated control supply voltage U_s	A1-A2	24-240 V AC/DC	24 V AC/DC
Rated control supply voltage U_s tolerance		-15...+10 %	
Typical current / power / consumption	24 V DC	33 mA / 0.8 VA	18 mA / 0.45 VA
	115 V AC	12.5 mA / 1.5 VA	n/a
	230 V AC	13 mA / 2.9 VA	n/a
Rated frequency	AC	15-400 Hz	50/60 Hz
Frequency range	AC	13.5-440 Hz	45-65 Hz
Power failure buffering time	min.	20 ms	
Measuring circuit		T1, T2, T3	
Sensor type		PT100	
Connection of the sensor	2-wire	yes, jumper between T2-T3	
	3-wire	yes, use terminal T1, T2, T3	
Monitoring function		overtemperature, undertemperature or window monitoring	
Threshold values adjustable within the measuring range	CM-TCS.x1	-50...+50 °C	
	CM-TCS.x2	0...+100 °C	
	CM-TCS.x3	0...+200 °C	
Number of possible thresholds		2	
Tolerance of the adjusted threshold value		typ. ± 5 % of the range end value	
Hysteresis related to the threshold value		2-20 % of threshold value, min. 1 °C	
Measuring principle		continuous current	
Typical current in the sensor circuit		0.8 mA	
Maximum current in sensor circuit		0.9 mA	
Interrupted wire detection		yes, indicated via LED status	
Short-circuit detection		yes, indicated via LED status	
Accuracy within the rated control supply voltage tolerance		< 0.2 °C / or < 0.01 %/K	
Accuracy within the temperature range		< 0.2 °C / or < 0.01 %/K	
Repeat accuracy (constant parameters)		< 0.2 % of full scale	
Maximum measuring cycle		320 ms	
Output circuit			
Kind of output		2 x 1 or 1 x 2 c/o (SPDT) contacts configurable	
Operating principle		open- or closed-circuit principle configurable ¹⁾	
Contact material		AgNi alloy, Cd free	
Rated operational voltage (IEC/EN 60947-1)		250 V AC / 300 V DC	
Minimum switching voltage / Minimum switching current		24 V / 10 mA	
Maximum switching voltage / Maximum switching current		see 'Load limit curves'	
Rated operating current I_n (IEC/EN 60947-1-5)	AC12 (resistive) 230 V	4 A	
	AC15 (inductive) 230 V	3 A	
	DC12 (resistive) 24 V	4 A	
	DC13 (inductive) 24 V	2 A	
AC Rating (UL508)	utilization category	B 300, pilot duty general purpose (250 V, 4 A, $\cos \phi$ 0.75)	
	maximum rated operational voltage	250 V AC	
	maximum continuous thermal current at B 300	4 A	
	maximum making/breaking apparent power at B 300	3600/360 VA	
Mechanical lifetime		30 x 10 ⁹ switching cycles	
Electrical lifetime (AC12, 230 V, 4 A)		0.1 x 10 ⁹ switching cycles	
Maximum fuse rating to achieve short-circuit protection	n/c contact	6 A fast-acting	
	n/o contact	10 A fast-acting	
Conventional thermal current I_{th} acc. IEC/EN 60947-1		4 A	
General data			
Dimensions (W x H x D)		22.5 x 85.6 x 103.7 mm (0.89 x 3.37 x 4.08 in)	
Mounting position		any	
Weight	net weight	CM-TCS.1x	0.151 kg (0.333 lb)
		CM-TCS.2x	0.138 kg (0.304 lb)
	gross weight	CM-TCS.1x	0.176 kg (0.388 lb)
		CM-TCS.2x	0.163 kg (0.360 lb)
Degree of protection	enclosure / terminals	IP50 / IP20	
Ambient temperature range	operation	-40...+60 °C	
	storage/transport	-40...+85 °C	
Mounting		DIN rail (IEC/EN 60715), snap-on mounting without any tool	

¹⁾ Closed-circuit principle: Output relay(s) de-energize(s) if measured value exceeds or falls below the adjusted threshold value

Temperature monitoring relays

Technical data - CM-TCS.xx

Type	CM-TCS.11/12/13'		CM-TCS.21/22/23
Electrical connection			
Wire size		Screw connection technology	Easy Connect Technology (Push-in)
fine-strand without wire end ferrule	A1, A2, 11, 12, 14, 21, 22, 24	1 x 0.5-2.5 mm ² (1 x 20-14 AWG) 2 x 0.5-1.5 mm ² (2 x 20-16 AWG)	2 x 0.5-1.5 mm ² (2 x 20-16 AWG) connection with lever
	T1, T2, T3	1 x 0.2-2.5 mm ² (1 x 24-14 AWG) 2 x 0.2-1.5 mm ² (2 x 24-16 AWG)	2 x 0.2-1.5 mm ² (2 x 24-16 AWG) connection with lever
	A1, A2, 11, 12, 14, 21, 22, 24	1 x 0.5-2.5 mm ² (1 x 20-14 AWG) 2 x 0.5-1.5 mm ² (2 x 20-16 AWG)	2 x 0.5-1.5 mm ² (2 x 20-16 AWG) connection: push-in
	T1, T2, T3	1 x 0.2-2.5 mm ² (1 x 24-14 AWG) 2 x 0.2-1.5 mm ² (2 x 24-16 AWG)	2 x 0.2-1.5 mm ² (2 x 24-16 AWG) insulated ferrule (DIN 46228-4-E); connection: push-in ferrule (DIN 46228-1-A): < 0.5 mm ² , connection with lever ≥ 0.5 mm ² , connection: push-in
rigid	A1, A2, 11, 12, 14, 21, 22, 24	1 x 0.5-4 mm ² (1 x 20-12 AWG) 2 x 0.5-2.5 mm ² (2 x 20-14 AWG)	2 x 0.5-1.5 mm ² (2 x 20-16 AWG) connection: push-in
	T1, T2, T3	1 x 0.2-4 mm ² (1 x 24-12 AWG) 2 x 0.2-2.5 mm ² (2 x 24-14 AWG)	2 x 0.2-1.5 mm ² (2 x 24-16 AWG) < 0.5 mm ² , connection with lever ≥ 0.5 mm ² , connection: push-in
Stripping length		8 mm (0.32 in)	
Tightening torque	< 0.5 mm ²	0.5 Nm (4.43 lb.in)	-
	≥ 0.5 mm ²	0.6 - 0.8 Nm (5.31 - 7.08 lb.in)	-
Standards			
Product standard	IEC/EN 60255-6: 2008		
Other standards	EN 50178, IEC/EN 60204		
Low Voltage Directive	2006/95/EC		
EMC Directive	2004/108/EC		
RoHS Directive	2002/95/EC		
Environmental data			
Ambient temperature ranges	operation/storage/ transport	-40...+60°C/-40...+85°C/-40...+85°C	
Climatic category		3K5 (no condensation, no ice formation)	
Damp heat, cyclic		6 x 24 h cycle, 55 °C, 95 % RH	
Vibration, sinusoidal		Class 2	
Shock		Class 2	
Isolation data			
Rated impulse withstand voltage U _{imp} between all isolated circuits (IEC/EN 60947-1, IEC/EN 60664-1)	supply circuit / measuring circuit	4 kV	-
	supply circuit / output circuits	4 kV	
	measuring circuit / output circuits	4 kV	
	output circuit 1 / output circuit 2	4 kV	
Pollution degree (IEC/EN 60664-1)		3	
Overvoltage category (IEC/EN 60664-1)		III	
Rated insulation voltage U _i (IEC/EN 60947-1, IEC/EN 60664-1)	supply circuit / measuring circuit	300 V	-
	supply circuit / output circuits	300 V	
	measuring circuit / output circuits	300 V	
	output circuit 1 / output circuit 2	300 V	
Basis isolation for rated control supply voltage (IEC/EN 60664-1)	supply circuit / measuring circuit	250 V AC / 300 V DC	-
	supply circuit / output circuits	250 V AC / 300 V DC	
	measuring circuit / output circuits	250 V AC / 300 V DC	
	output circuit 1 / output circuit 2	250 V AC / 300 V DC	
Protective separation (IEC/EN 61140, EN 50178)	supply circuit / measuring circuit	250 V AC / 250 V DC	-
	supply circuit / output circuits	250 V AC / 300 V DC	250 V AC / 250 V DC
	measuring circuit / output circuits	250 V AC / 300 V DC	250 V AC / 250 V DC
	output circuit 1 / output circuit 2	250 V AC / 300 V DC	
Test voltage between all isolated circuits, routine test (IEC/EN 60255-5, IEC/EN 61010-1)	supply circuit / measuring circuit	2.0 kV, 50 Hz, 1 s	-
	supply circuit / output circuits	2.0 kV, 50 Hz, 1 s	
	measuring circuit / output circuits	2.0 kV, 50 Hz, 1 s	
	output circuit 1 / output circuit 2	2.0 kV, 50 Hz, 1 s	
Test voltage between all isolated circuits, type test (IEC/EN 60255-5)	supply circuit / measuring circuit	4.0 kV, 50 Hz, 1 s	-
	supply circuit / output circuits	4.0 kV, 50 Hz, 1 s	
	measuring circuit / output circuits	4.0 kV, 50 Hz, 1 s	
	output circuit 1 / output circuit 2	4.0 kV, 50 Hz, 1 s	
Electromagnetic compatibility			
Interference immunity to		IEC/EN 61000-6-1, IEC/EN 61000-6-2, IEC/EN 61326-2-4	
electrostatic discharge	IEC/EN 61000-4-2	Level 3, 6 kV / 8 kV	
radiated, radio-frequency, electromagnetic field	IEC/EN 61000-4-3	Level 3, 10 V/m (1 GHz) / 3 V/m (2 GHz) / 1 V/m (2.7 GHz)	
electrical fast transient/burst	IEC/EN 61000-4-4	Level 3, 2 kV / 5 kHz	
surge	IEC/EN 61000-4-5	Level 3, installation class 3, supply circuit and measuring circuit 1 kV L-L, 2 kV L-earth	
conducted disturbances, induced by radio-frequency fields	IEC/EN 61000-4-6	Level 3, 10 V	
voltage dips, short interruptions and voltage variations	IEC/EN 61000-4-11	Class 3	
harmonics and interharmonics	IEC/EN 61000-4-13	Class 3	
Interference emission		EN 61000-6-3, EN 61000-6-4	
high-frequency radiated	IEC/CISPR 22, EN 55022	Class B	
high-frequency conducted	IEC/CISPR 22, EN 55022	Class B	

Temperature monitoring relays

Technical data - C51x

Type		C512	C513
Input circuit			
Rated control supply voltage U_s	A1-A2	24 V AC/DC	-
Power consumption	A1-A2	24-240 V AC/DC	
	AC	< 7 VA	
	DC	< 4 W	
Rated control supply voltage U_s tolerance		-15...+10 %	
Rated frequency	AC		
Sensor circuit			
Sensor type		PT100, PT1000, KTY83, KTY84, NTC	
Sensor current	PT100	typ. 1 mA	
	PT1000, KTY83, KTY84, NTC	typ. 0.2 mA	
Wire-break detection		yes (not for NTC)	
Short-circuit detection		yes	
3-wire connection		yes (2-wire connection of sensors with terminals T2 and T3 bridged)	
Measuring circuit			
Setting accuracy at $T_a = 20\text{ °C}$ (T_{20})		< $\pm 2\text{ K} \pm 1\text{ digit}$	
Accuracy within the temperature range		0.05 °C / °C deviation from T_{20}	
Response time		500 ms	
Hysteresis settings	temperature 1	1-99 kelvin	
	temperature 2	1-99 kelvin	
Tripping delay		0-999 s	
Output circuit			
Kind of output		2 c/o + 1n/o	2 c/o + 1 n/o
Rated operating current I_a (IEC/EN 60947-1-5)	AC12 (resistive) 230 V	n/a	
	AC15 (inductive) 230 V	3 A	
	DC12 (resistive) 24 V	1 A	
	DC13 (inductive) 24 V	0.1 A	
			30 x 10 ⁶ switching cycles
Mechanical lifetime		0.1 x 10 ⁵ switching cycles	
Electrical lifetime (AC15 at 3 A)		4 A, operating class gL/gG	
Max. fuse rating to achieve short-circuit protection			
General data			
Dimensions (W x H x D)		45 x 105.9 x 86 mm (1.77 x 4.17 x 3.39 in)	
Tightening torque		0.8-1.2 Nm	
Mounting position		any	
Degree of protection	enclosure / terminals	IP 40 / IP 20	
Ambient temperature range	operation	-25...+60 °C	
	storage	-40...+80 °C	
Mounting		DIN rail (IEC/EN 60715)	
Electrical connection			
Wire size	rigid	1 x 4 mm ² (1 x 12 AWG), 2 x 2.5 mm ² (2 x 14 AWG)	
	fine-strand with wire end ferrule	1 x 2.5 mm ² (1 x 14 AWG), 2 x 1.5 mm ² (2 x 16 AWG)	
Standards			
Environmental conditions		IEC 60721-3-3	
Low Voltage Directive		IEC 60947-5-1, VDE 0660	
Electromagnetic compatibility	Interference immunity	EN 61000-6-2	
	Interference emission	EN 61000-6-4	
Vibration resistance (IEC 68-2-6)		5-26 Hz / 0.75 mm	
Shock resistance (IEC 68-2-27)		15 g / 11 ms	
Isolation data			
Rated insulation voltage		300 V AC	
Pollution degree		3	

Liquid level monitors and controls

Product group picture

2



Liquid level monitors and controls

Table of contents

Liquid level monitors and controls	
Product group picture	111
Table of contents	112
Benefits and advantages	113
Operating controls	114
Ordering details	115
Ordering details - Accessories	116
Function diagrams	117
Connection diagrams	119
Application examples	120
Application examples	121
Technical data	122

Liquid level monitors and controls

Benefits and advantages

2

CM-ENE MIN/MAX

- Monitoring of pump systems for dry running (ENE MIN) and overflow (ENE MAX)
- Connection of 2 electrodes possible at C and MIN/MAX
- 3 supply voltage versions
- Optimal price/performance ratio
- 1 n/o contact: Open-circuit principle for CM-ENE MIN, Closed-circuit principle for CM-ENE MAX
- LED for status indication

CM-ENS

- Monitoring and control of liquid levels (when draining or filling liquids in tanks)
- Monitoring and control of mixture ratios (conductivity of liquids)
- Adjustable response sensitivity 5-100 k Ω
- 4 supply voltage versions 24 - 415 V AC
- Version with protective separation acc. to VDE 0160 
- Cascadable
- 1 c/o contact or 1 n/o and 1 n/c contact
- 2 LEDs for status indication

CM-ENS UP/DOWN

- Monitoring and control of liquid levels
- Selectable function "fill" or "drain"
- Adjustable response sensitivity 5-100 k Ω
- Cascadable
- 1 c/o contact
- 2 LEDs for status indication

CM-ENN

- Monitoring and control of liquid levels (when emptying or filling liquids in tanks)
- Monitoring and control of mixture ratios (conductivity of liquids)
- 3 response sensitivities from 250 Ω - 500 k Ω in one unit
- 5 supply voltage versions 24 V AC/DC - 415 V AC
- Selectable ON- or OFF-delay 0.1-10 s
- 2 c/o contacts
- 2 LEDs for status indication

CM-ENN UP/DOWN

- Liquid level relay with 5 electrode inputs
- Level control with integrated overflow and dry-running protection
- Adjustable response sensitivity 5-100 k Ω
- Cascadable
- 1 c/o contact and 2 n/c contacts as alarm outputs
- 4 LEDs for status indication

Liquid level monitors and controls

Operating controls

CM-ENS



- 1** „Sens.“ - sensitivity potentiometer for adjusting the response sensitivity
- 2** Indication of operational states
R: yellow LED - relay status
U: green LED - control supply voltage
- 3** Marker label

CM-ENN



- 1** „Function.“ - function selector switch:
„UP“ - fill
„DOWN“ - drain
- 2** „Sens.“ - potentiometer for adjusting the response sensitivity
- 3** Indication of operational states
R: MIN/MAX: yellow LED - relay status MIN/MAX
U: green LED - control supply voltage
R AL1: yellow LED - relay status AL1
R AL2: yellow LED - relay status AL2
- 4** Marker label

Liquid level monitors and controls

Ordering details

2



CM-ENE MIN



CM-ENE MAX



CM-ENS



CM-ENN

Description

ABB's liquid level monitoring relays for regulation and control of liquid levels and ratios of mixtures of conductive fluids.

The assortment includes single function and multifunction monitoring relays which can be used for overflow and dry-running protection, for filling and draining applications, for max and min alarm or any combination of such functions. Furthermore a wide range of accessories is available

Ordering details

Rated control supply voltage	Type	Order code	Price 1 pce	Weight (1 pce) kg (lb)
24 V AC	CM-ENE MIN	1SVR550855R9500		0.15 (0.33)
110-130 V AC		1SVR550850R9500		0.15 (0.33)
220-240 V AC		1SVR550851R9500		0.15 (0.33)
24 V AC	CM-ENE MAX	1SVR550855R9400		0.15 (0.33)
110-130 V AC		1SVR550850R9400		0.15 (0.33)
220-240 V AC		1SVR550851R9400		0.15 (0.33)
24 V AC	CM-ENS	1SVR430851R9100		0.15 (0.33)
110-130 V AC		1SVR430851R0100		0.15 (0.33)
220-240 V AC		1SVR430851R1100		0.15 (0.33)
380-415 V AC		1SVR430851R2100		0.15 (0.33)
220-240 V AC ¹⁾		1SVR430851R1300		0.15 (0.33)
24 V AC		CM-ENS UP/DOWN	1SVR430851R9200	
110-130 V AC	1SVR430851R0200			0.15 (0.33)
220-240 V AC	1SVR430851R1200			0.15 (0.33)
24-240 V AC/DC	CM-ENN	1SVR450055R0000		0.30 (0.66)
24 V AC		1SVR450059R0000		0.30 (0.66)
110-130 V AC		1SVR450050R0000		0.30 (0.66)
220-240 V AC		1SVR450051R0000		0.30 (0.66)
380-415 V AC	CM-ENN UP/DOWN	1SVR450052R0000		0.30 (0.66)
24 V AC		1SVR450059R0100		0.15 (0.33)
110-130 V AC		1SVR450050R0100		0.15 (0.33)
220-240 V AC	CM-ENN UP/DOWN	1SVR450051R0100		0.15 (0.33)
380-415 V AC		1SVR450052R0100		0.15 (0.33)

¹⁾ Version with protective separation acc. to VDE 0160, 1 n/o, 1 n/c

Liquid level monitors are

Suitable for		Not suitable for	
spring water	acids, bases	chemically pure water	ethylene glycol
drinking water	liquid fertilizers	fuel	concentrated alcohol
sea water	milk, beer, coffee	oils	paraffin
sewage	non-concentrated alcohol	explosive areas (liquid gas)	lacquers

Liquid level monitors and controls

Ordering details - Accessories

Compact support CM-KH-3 for 3 bar electrodes

- Ideally suited for use with liquid level relays CM-ENS and CM-ENN
- Wire connection by screw terminals
- Pull relief by M16 screwed cable glands
- Temperature range up to 90 °C
- Food safe material (PPH)
- Screw-in electrodes (M4 thread)
- Distance plate (CM-AH-3) and locking nut (CM-GM-1) optionally available as an accessory

Compact support CM-KH-3 (Dimensions in mm)

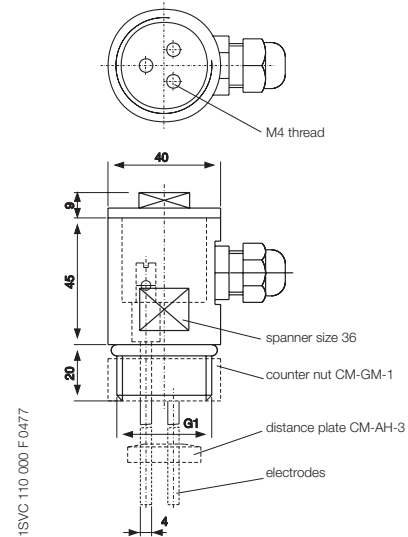
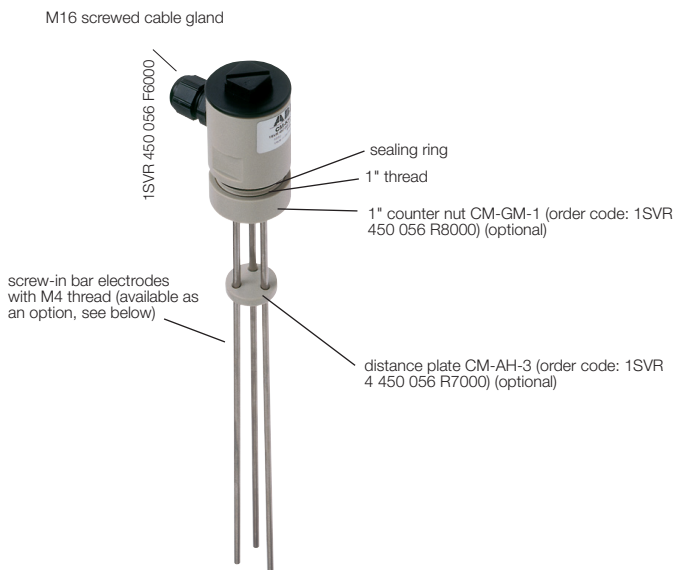

Distance plate CM-AH-3

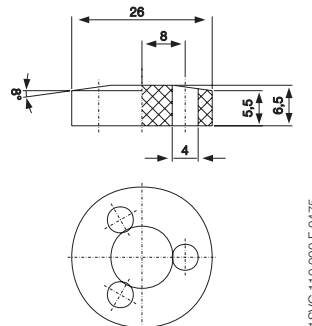

Counter nut CM-GM-1

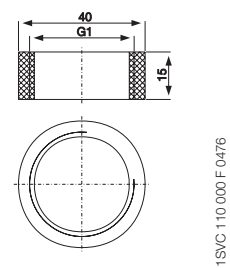

Technical data compact support

Type of mounting:	G 1" thread
Mounting position:	any
Enclosure material:	PPH
Sealing:	NBR 70
Temperature range:	90 °C max.
Pressure:	10 bar max. (60 °C)

Description	Type	Order code	Price	Pkg qty	Weight (1 pce) kg (lb)
Compact support for 3 bar electrodes	CM-KH-3	1SVR450056R6000			0.06 (0.132)
Distance plate for 3 bar electrodes	CM-AH-3	1SVR450056R7000		1	0.06 (0.132)
Counter nut for 1" thread	CM-GM-1	1SVR450056R8000			0.06 (0.132)

Screw-in bar electrodes for compact support CM-KH-3

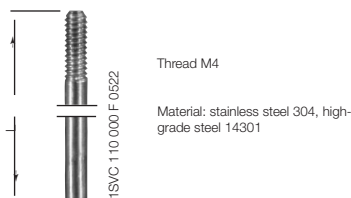

During project engineering the compatibility of the electrode material with the medium to be supervised is to be examined!

Suspension electrode CM-HE

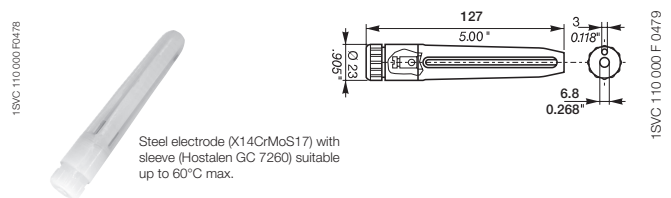

Lenght	Type	Order code	Price	Pkg qty	Weight (1 pce) kg (lb)
300 mm	CM-SE-300	1SVR450056R0000			0.08 (0.176)
600 mm	CM-SE-600	1SVR450056R0100			0.08 (0.176)
1000 mm	CM-SE-1000	1SVR450056R0200		1	0.08 (0.176)
CM-HE	CM-HE	1SVR402902R0000			0.08 (0.176)

Liquid level monitors and controls

Function diagrams

Function diagram - CM-ENS

2

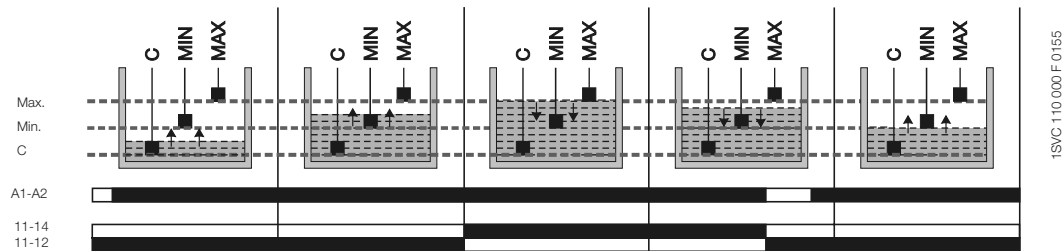

The CM-ENS monitors levels of conductive liquids and is used for example for liquid level control in pump systems. It can be used for filling or draining tanks for example. It is also suitable for monitoring the conductivity of liquids. The measuring principle is based on the resistance change sensed by single-pole electrodes. After the supply voltage is applied to the terminals A1 and A2, the output relay is de-energized. The probes must be connected to C, MAX, MIN. The output relay energizes if the liquid exceeds the maximum level (C and MAX wet) and de-energizes if the liquid level is below the minimum level (MAX and MIN dry). Based on the measuring circuit there will be a response delay of approx. 250 ms at maximum sensitivity. Different levels in one tank can be controlled by up to 5 CM-ENS without interfering with each other.

Function diagram - CM-ENN UP/DOWN

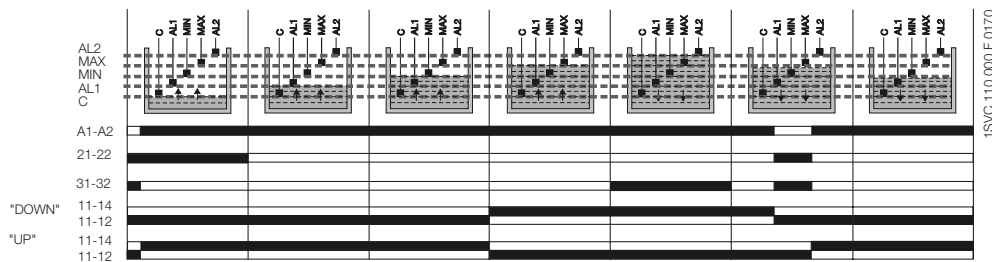

If a metal tank is used, the ground reference electrode C is not required. In this case the cable can be connected directly to the metal surface of the tank.

The CM-ENN UP/DOWN monitors levels of conductive liquids and media and is used e.g. for liquid level control in pump systems. The measuring principle is based on the resistance change sensed by single-pole electrodes. The function of the output relay 11-12/14 can be selected by a selector switch on the front of the unit to fill "UP" or drain "DOWN". If the "UP" function is selected, the output relay is energized until the MAX electrode becomes wet. Then it is de-energized and not re-energized until the MIN electrode becomes dry. If the "DOWN" function is selected, the output relay is energized as soon as the MAX electrode becomes wet. It remains energized until the liquid level has dropped below the MIN electrode. The electrode inputs AL1 and AL2 energize/de-energize the corresponding output relays RAL1 (21-22) and RAL2 (31-32). AL1 opens if contact RAL1 (21-22) is wet. AL2 closes if contact RAL2 (31-32) is wet. This way, two additional alarm outputs for exceeding or dropping below the normal level can be implemented in addition to the filling levels MAX and MIN.

Function diagram - CM-ENS UP/DOWN

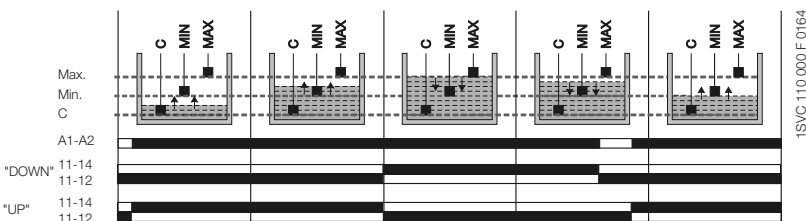

The CM-ENS UP/DOWN monitors levels of conductive liquids and other media, and is used e.g. for liquid level control in pump systems.

The measuring principle is based on the resistance change sensed by single-pole electrodes. The output relay functions fill (UP) or drain (DOWN) can be selected on a front-face selector switch. If the "UP" function is selected, the output relay is energized until the MAX electrode becomes wet. Then it is de-energized and not re-energized until the MIN electrode becomes dry. If the "DOWN" function is selected, the output relay is energized as soon as the MAX electrode becomes wet. It remains energized until the liquid level has dropped below the MIN electrode. The electrodes can be connected to more than one CM-ENS unit without interference.

Liquid level monitors and controls

Function diagrams

Function diagrams - CM-ENN

Circuit with 2 electrodes

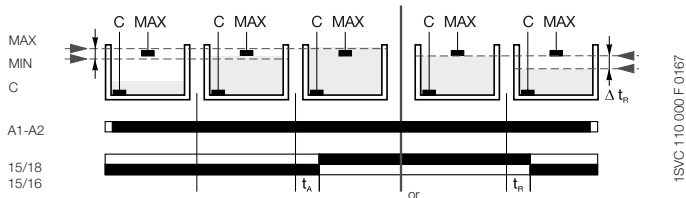

1SVC 110 000 F 0167

The CM-ENN monitors levels of conductive liquids and is used for example for liquid level monitoring in pump control systems, for dry-running protection of submersible pumps or overflow monitoring of tanks. It is also suitable for conductivity monitoring of liquids. The measuring principle is based on the resistance change sensed by single-pole electrodes (wet or dry).

Instead of electrodes, other sensors or transducers can also be used if their output quantities are different resistance values. The measuring, output and supply circuits are electrically isolated for potential separation and to prevent electrical interference.

Due to the integrated ON- or OFF-delay, it is possible to set up time-dependent liquid controls using only two electrodes (C, MAX). Different liquid levels in one tank can be controlled by up to 5 CM-ENN (AC version) without mutual interference.

Circuit with 3 electrodes

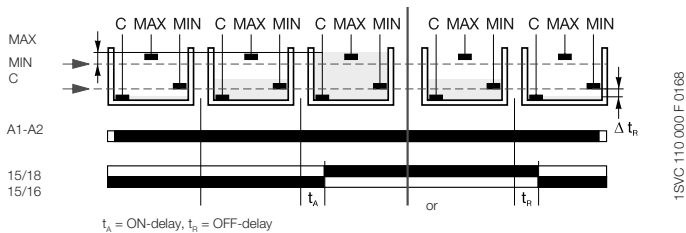

1SVC 110 000 F 0168

Function diagram - CM-ENE MIN

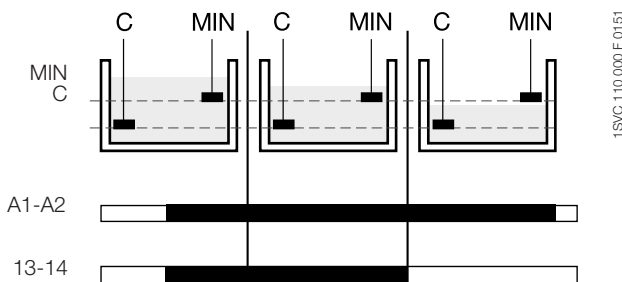

1SVC 110 000 F 0151

The liquid level relays CM-ENE MIN and CM-ENE MAX are used to monitor levels of conductive liquids, for example in pump control systems for dry-running or overflow monitoring.

The measuring principle is based on the occurring resistance change when moistening single-pole electrodes. The single-pole electrodes (see also section Accessories) are connected to the terminals C and MIN or MAX.

If the supply voltage is applied to A1-A2 and the electrodes are wet, the output relay of the CM-ENE MIN is energized and the output relay of the CM-ENE MAX is de-energized.

The output relay of the CM-ENE MIN de-energizes if the electrodes are no longer wet. The output relay of the CM-ENE MAX energizes if the electrodes are no longer wet.

Function diagram CM-ENE MAX

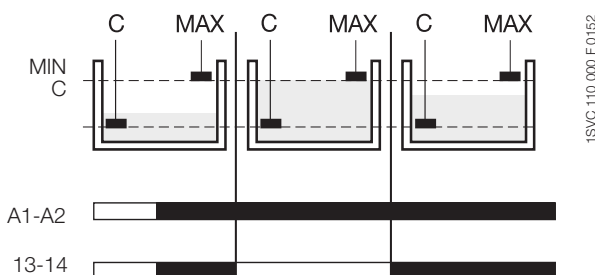

1SVC 110 000 F 0152

Liquid level monitors and controls

Connection diagrams

2

Connection diagram CM-ENE MIN

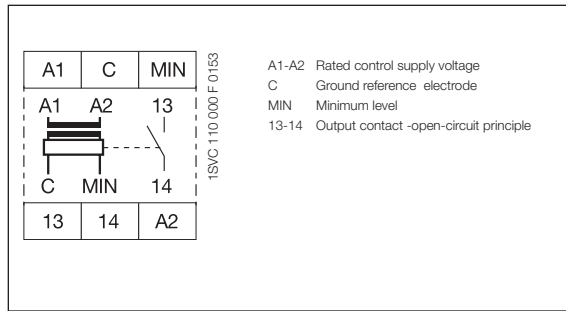

Connection diagram CM-ENE MAX

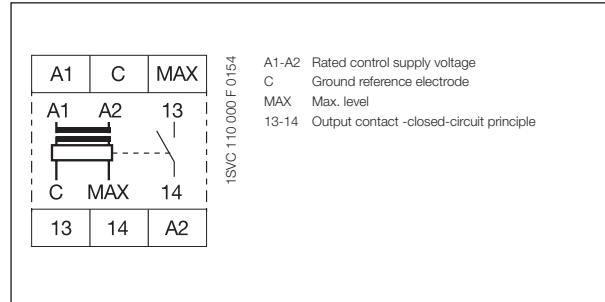

Connection diagram CM-ENS

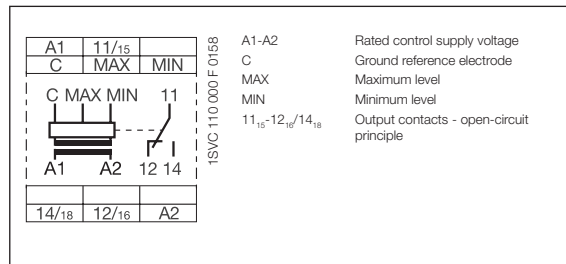

Connection diagram CM-ENN

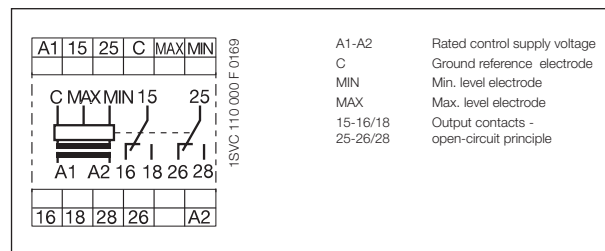

Connection diagram CM-ENS UP/DOWN

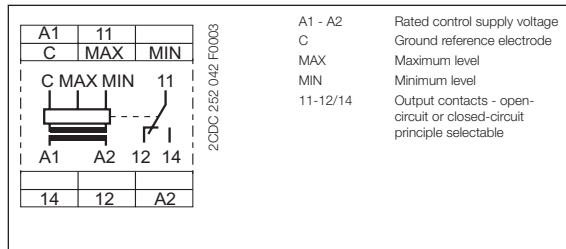

Connection diagram CM-ENN UP/DOWN

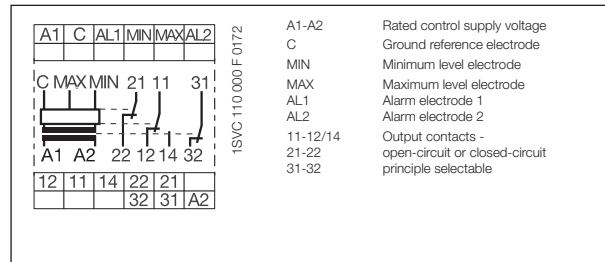

Liquid level monitors and controls

Application examples

Application examples CM-ENE MIN/MAX

CM-ENE MIN

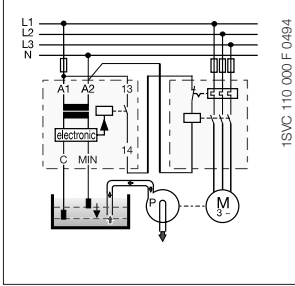

CM-ENE MAX

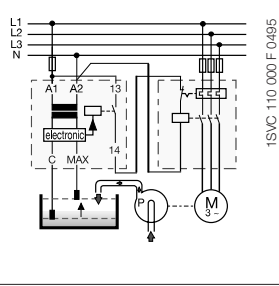

CM-ENE MIN und CM-ENE MAX

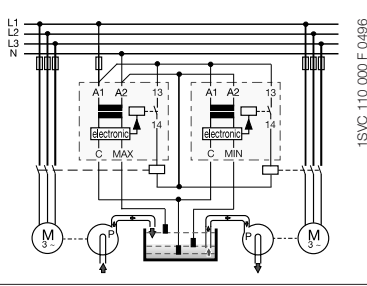

Application examples CM-ENS

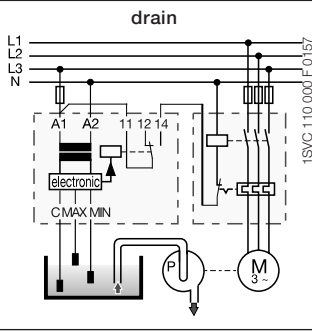
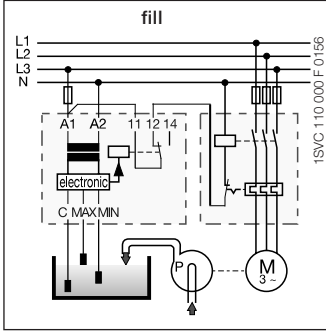

Cascading
The electrode inputs can be interconnected as required, which ensures simple monitoring of different liquid levels.

1SVC 110 000 F 0159

Redundancy
Redundant liquid level monitoring or control can be implemented by connecting the electrodes to two units. This makes the application much safer.

1SVC 110 000 F 0160

Application examples CM-ENS UP/DOWN

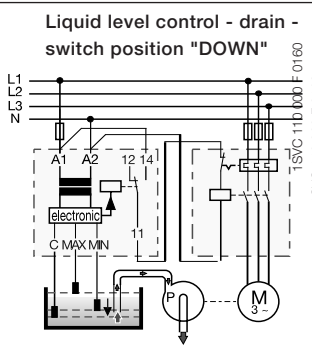
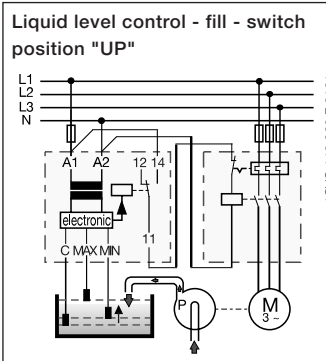

Cascading of electrodes
The electrode inputs can be interconnected as required, which ensures simple monitoring of different liquid levels.

1SVC 110 000 F 0159

Redundancy
Redundant liquid level monitoring or control can be implemented by connecting the electrodes to two units. This makes the application much safer.

1SVC 110 000 F 0160

Liquid level monitors and controls

Application examples

Application examples CM-ENN

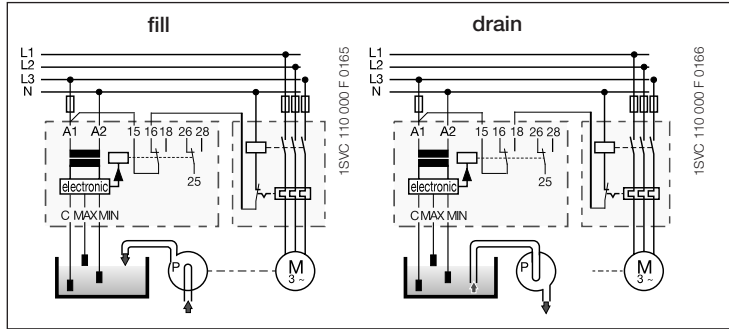

For commissioning, set both potentiometers (response sensitivity = R value and ON-delay = time value) to the minimum value (5) and select a suitable resistance range (sector). After all electrodes have been wetted by the liquid being monitored, turn the sensitivity potentiometer towards maximum value (100) until the relay de-energizes. If the relay does not energize, select a higher Ω value (sector) on the device and proceed as before. Then it has to be checked if the relay de-energizes properly as soon as the electrodes C and MIN are no longer wet. Liquid levels higher than the maximum level electrode can be obtained by setting an ON-delay (TA = 0.1...10 s).

Liquid levels lower than the minimum level electrode can be obtained by setting an OFF-delay time (TR = 0.1...10 s), e.g. for emptying tanks.

Application example CM-ENN UP/DOWN

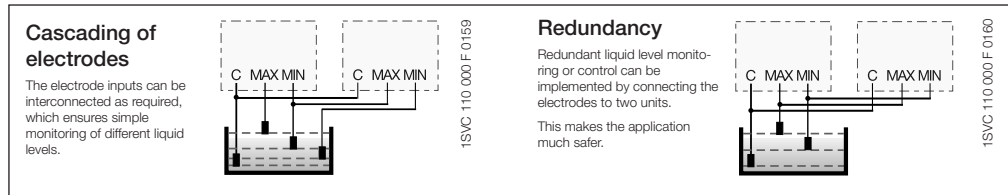
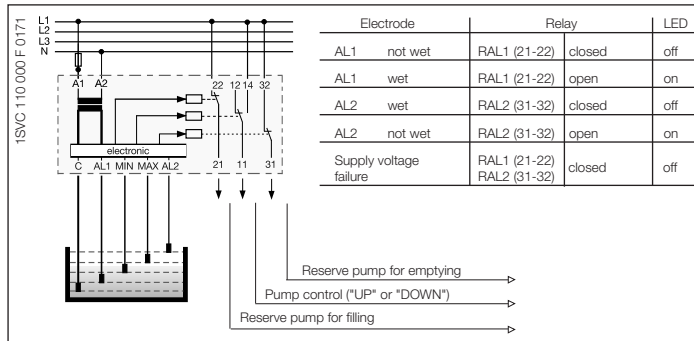

Liquid level monitors and controls

Technical data

Type		CM-ENE MIN	CM-ENE MAX
Supply circuit			
Rated control supply voltage U_s - power consumption	A1-A2	24 V AC	approx. 1.5 VA
	A1-A2	110-130 V AC	approx. 1.2 VA
	A1-A2	220-240 V AC	approx. 1.4 VA
Rated control supply voltage U_s tolerance		-15...+15 %	
Rated frequency		50-60 Hz	
Duty time		100 %	
Measuring circuit		MIN-C, MAX-C	
Monitoring function		dry-running protection	overflow protection
Response sensitivity		0-100 k Ω , not adjustable	
Maximum electrode voltage		30 V AC	
Maximum electrode current		1.5 mA	
Electrode supply line	max. cable capacity	3 nF	
	max. cable length	30 m	
Timing circuit			
Time delay		-	
Tripping delay		fixed approx. 200 ms	
Indication of operational states			
Output relay energized		R: yellow LED	
Output circuits		13-14	
Kind of output		1 n/o contact	
Operational principle ¹⁾		open-circuit principle	closed-circuit principle
Contact material		AgCdO	
Rated operational voltage U_o (IEC/EN 60947-1)		250 V	
Minimum switching voltage / minimum switching current		- / -	
Maximum switching voltage		250 V	
Rated operational current I_o (IEC/EN 60947-5-1)	AC12 (resistive) 230 V	4 A	
	AC15 (inductive) 230 V	3 A	
	DC12 (resistive) 24 V	4 A	
	DC13 (inductive) 24 V	2 A	
AC rating (UL 508)	Utilization category (Control Circuit Rating Code)	B 300	
	max. rated operational voltage	300 V AC	
	max. continuous thermal current at B 300	5 A	
	max. making/breaking apparent power at B 300	3600/360 VA	
Mechanical lifetime		30 x 10 ⁶ switching cycles	
Electrical lifetime (AC12, 230 V, 4 A)		0.3 x 10 ⁶ switching cycles	
Max. fuse rating to achieve short-circuit protection	n/c contact	-	
	n/o contact	10 A fast-acting	
General data			
Dimensions (W x H x D)		22.5 x 78 x 78.5 mm (0.89 x 3.07 x 3.09 in)	
Mounting position		any	
Degree of protection	enclosure / terminals	IP50 / IP20	
Ambient temperature range	operation / storage	-20...+60 °C / -40...+85 °C	
Mounting		DIN rail (IEC/EN 60715)	
Electrical connection			
Wire size	fine-strand with wire-end ferrule	2 x 0.75-1.5 mm ² (2 x 18-16 AWG)	
	fine-strand without wire-end ferrule	2 x 1-1.5 mm ² (2 x 18-16 AWG)	
	rigid	2 x 0.75-1.5 mm ² (2 x 18-16 AWG)	
Stripping length		10 mm (0.39 inch)	
Tightening torque		0.6-0.8 Nm	
Standards			
Product standard		IEC 255-6, EN 60255-6	
Low Voltage Directive		2006/95/EC	
EMC Directive		2004/108/EC	
Electromagnetic compatibility		EN 61000-6-2, EN 61000-6-4	
electrostatic discharge	IEC/EN 61000-4-2	Level 3 (6 kV / 8 kV)	
radiated, radio-frequency, electromagnetic field	IEC/EN 61000-4-3	Level 3 (10 V/m)	
electrical fast transient / burst	IEC/EN 61000-4-4	Level 3 (2 kV / 5 kHz)	
surge	IEC/EN 61000-4-5	Level 4 (2 kV L-L)	
conducted disturbances, induced by radio-frequency fields	IEC/EN 61000-4-6	Level 3 (10 V)	
Resistance to vibration (IEC 68-2-6)		6 g	
Mechanical resistance (IEC 68-2-6)		10 g	
Isolation data			
Rat. insulation volt. betw. supply, meas. & output circuit (VDE 0110, IEC 60947)		250 V	
Rated impulse withstand voltage between all isolated circuits (VDE 0110, IEC 664)		4 kV / 1.2-50 μ s	
Test voltage between all isolated circuits		2.5 kV, 50 Hz, 1 min.	
Pollution category (VDE 0110, IEC 664, IEC 255-5)		3 / C	
Overvoltage category (VDE 0110, IEC 664, IEC 255-5)		III / C	
Environmental testing (IEC 68-2-30)		24 h cycle time, 55 °C, 93 % rel., 96 h	

¹⁾ Open-circuit principle: Output relay energizes if the measured value exceeds/drops below the adjusted threshold.

Closed-circuit principle: Output relay de-energizes if the measured value exceeds/drops below the adjusted threshold.

Liquid level monitors and controls

Technical data

2

Type		CM-ENS	CM ENS UP/DOWN
Supply circuit			
Rated control supply voltage U_s -	A1-A2	24 V AC	24 V AC
power consumption	A1-A2	110-130 V AC approx. 1.5 VA	110-130 V AC approx. 4 VA
	A1-A2	220-240 V AC approx. 1.5 VA	220-240 V AC approx. 4 VA
	A1-A2	380-415 V AC approx. 1.5 VA	
Rated control supply voltage U_s tolerance		-15...+10 %	
Rated frequency		50-60 Hz	
Duty time		100 %	
Measuring circuit		MAX-MIN-C	
Monitoring function		liquid level control	
Response sensitivity		5-100 k Ω , adjustable	
Maximum electrode voltage		30 V AC	
Maximum electrode current		1 mA	
Electrode supply line	max. cable capacity	10 nF	
	max. cable length	100 m	
Timing circuit			
Time delay		-	
Tripping delay		approx. 250 ms	
Indication of operational states			
Control supply voltage		U: green LED	
Output relay energized		R MAX/MIN: yellow LED	
Alarm relay AL1		-	R AL1: yellow LED
Alarm relay AL2		-	R AL2: yellow LED
Output circuits		11-12/14, 21-22, 31-32	
Kind of output		1 c/o contact, 1 n/o + 1 n/c contact ²⁾	
Operational principle ¹⁾		open-circuit principle	open- and closed-circuit principle
Contact material		AgCdo	
Rated operational voltage U_e (IEC/EN 60947-1)		250 V	
Minimum switching voltage / minimum switching current		- / -	
Maximum switching voltage		250 V	
Rated operational current I_e (IEC/EN 60947-5-1)	AC12 (resistive) 230 V	4 A	
	AC15 (inductive) 230 V	3 A	
	DC12 (resistive) 24 V	4 A	
	DC13 (inductive) 24 V	2 A	
AC rating (UL 508)	Utilization category (Control Circuit Rating Code)	B 300	
	max. rated operational voltage	300 V AC	
	max. continuous thermal current at B 300	5 A	
	max. making/breaking apparent power at B 300	3600/360 VA	
Mechanical lifetime		30 x 10 ⁶ switching cycles	
Electrical lifetime (AC12, 230 V, 4 A)		0.3 x 10 ⁶ switching cycles	
Max. fuse rating to achieve short-circuit protection	n/c / n/o contact	10 A fast-acting / 10 A fast-acting	
General data			
Dimensions (W x H x D)		22.5 x 70 x 100 mm (0.89 x 3.07 x 3.94 in)	
Mounting position		any	
Degree of protection	enclosure / terminals	IP50 / IP20	
Ambient temperature range	operation / storage	-20...+60 °C / -40...+85 °C	
Mounting		DIN rail (IEC/EN 60715)	
Electrical connection			
Wire size	fine-strand with wire end ferrule	2 x 2.5 mm ² (2 x 14 AWG)	
Standards			
Product standard		IEC 255-6, EN 60255-6	
Low Voltage Directive		2006/95/EC	
EMC Directive		2004/108/EC	
Electromagnetic compatibility			
electrostatic discharge	IEC/EN 61000-4-2	Level 3 (6 kV / 8kV)	
radiated, radio-frequency, electromagnetic field	IEC/EN 61000-4-3	Level 3 (10 V/m)	
electrical fast transient / burst	IEC/EN 61000-4-4	Level 3 (2 kV / 5 kHz)	
surge	IEC/EN 61000-4-5	Level 4 (2 kV L-L)	
conducted disturbances, induced by radio-frequency fields	IEC/EN 61000-4-6	Level 3 (10 V)	
Resistance to vibration (IEC 68-2-6)		4 g	
Mechanical resistance (IEC 68-2-6)		6 g	
Isolation data			
Rated insulation voltage between supply, measuring and output circuit (VDE 0110, IEC 60947)		250 V	
Rated impulse withstand voltage between all isolated circuits (VDE 0110, IEC 664)		4 kV / 1.2 - 50 μ s	
Test voltage between all isolated circuits		2.5 kV, 50 Hz, 1 min.	
Pollution category (VDE 0110, IEC 664, IEC 255-5)		3 / C	
Overvoltage category (VDE 0110, IEC 664, IEC 255-5)		III / C	
Environmental testing (IEC 68-2-30)		24 h cycle time, 55 °C, 93 % rel., 96 h	

¹⁾ Open-circuit principle: Output relay energizes if the measured value exceeds/drops below the adjusted threshold.
 Closed-circuit principle: Output relay de-energizes if the measured value exceeds/drops below the adjusted threshold.

²⁾ 1SVR 430 851 R1300 (version with safe isolation)

Liquid level monitors and controls

Technical data

Type		CM-ENN UP/DOWN	CM-ENN	
Supply circuit				
Rated control supply voltage U_s - power consumption	A1-A2	24 V AC	24 V AC	
	A1-A2	110-130 V AC approx. 1.5 VA	110-130 V AC approx. 2.5 VA	
	A1-A2	220-240 V AC approx. 1.5 VA	220-240 V AC approx. 3 VA	
	A1-A2	380-415 V AC approx. 1.5 VA	380-415 V AC approx. 4 VA	
	A1-A2		24-240 V AC/DC approx. 2 VA/W	
Rated control supply voltage U_s tolerance		-15...+10 %		
Rated frequency		50-60 Hz	50-60 Hz oder DC	
Duty time		100 %		
Measuring circuit				
		MAX-MIN-C		
Monitoring function		liquid level control		
Response sensitivity		adjustable	adjustable	
		5-100 k Ω	250 Ω - 5 k Ω : 2.5-50 k Ω : 25-500 k Ω	
Maximum electrode voltage		30 V AC	20 V AC	
Maximum electrode current		1 mA	8 mA	2 mA
Electrode supply line	max. cable capacity	10 nF	200 nF	20 nF
	max. cable length	100 m	1000 m	100 m
				20 m
Timing circuit				
Time delay		-	0.1-10 s, adjustable, ON- or OFF-delay	
Tripping delay		approx. 250 ms	-	
Indication of operational states				
Control supply voltage		U: green LED		
Output relay energized		R MAX/MIN: yellow LED	R: yellow LED	
Output circuits				
		11-12/14, 21-22, 31-32	15-16/18, 25-26/28	
Kind of output		1 c/o + 2 n/c contacts	2 c/o contacts	
Operational principle ¹⁾		open-circuit principle	open- and closed-circuit principle	
Contact material		AgCdO		
Rated operational voltage U_o	IEC/EN 60947-1	250 V	400 V	
Minimum switching voltage / minimum switching current		- / -		
Maximum switching voltage		250 V	400 V	
Rated operational current I_o (IEC/EN 60947-5-1)	AC12 (resistive) 230 V	4 A	5 A	
	AC15 (inductive) 230 V	3 A		
	DC12 (resistive) 24 V	4 A	5 A	
	DC13 (inductive) 24 V	2 A	2.5 A	
AC rating (UL 508)	Utilization category (Control Circuit Rating Code)	B 300		
	max. rated operational voltage	300 V AC		
	max. continuous thermal current at B 300	5 A		
	max. making/breaking apparent power at B 300	3600/360 VA		
Mechanical lifetime		30 x 10 ⁶ switching cycles		
Electrical lifetime (AC12, 230 V, 4 A)		0.3 x 10 ⁶ switching cycles	0.1 x 10 ⁶ switching cycles	
Max. fuse rating to achieve short-circuit protection	n/c / n/o contact	4 A fast-acting / 6 A fast-acting		
General data				
Dimensions (W X H X D)		45 x 78 x 100 mm (1.77 x 3.07 x 3.94 in)		
Mounting position		any		
Degree of protection	enclosure / terminals	IP50 / IP20		
Ambient temperature range	operation / storage	-25...+65 °C / -40...+85 °C		
Mounting		DIN rail (IEC/EN 60715)		
Electrical connection				
Wire size	fine-strand with wire end ferrule	2 x 2.5 mm ² (2 x 14 AWG)		
Standards				
Product standard		IEC 255-6, EN 60255-6		
Low Voltage Directive		2006/95/EC		
EMC Directive		2004/108/EC		
Electromagnetic compatibility				
electrostatic discharge	IEC/EN 61000-4-2	Level 3 (6 kV / 8kV)		
radiated, radio-frequency, electromagnetic field	IEC/EN 61000-4-3	Level 3 (10 V/m)		
electrical fast transient / burst	IEC/EN 61000-4-4	Level 3 (2 kV / 5 kHz)		
surge	IEC/EN 61000-4-5	Level 4 (2 kV L-L)		
conducted disturbances, induced by radio-frequency fields	IEC/EN 61000-4-6	Level 3 (10 V)		
Resistance to vibration (IEC 68-2-6)		5 g		
Mechanical resistance (IEC 68-2-6)		10 g		
Isolation data				
Rated insulation voltage between supply, measuring and output circuit (VDE 0110, IEC 60947)		250 V	500 V	
Rated impulse withstand voltage between all isolated circuits (VDE 0110, IEC 664)		4 kV / 1.2 - 50 μ s		
Test voltage between all isolated circuits		2.5 kV, 50 Hz, 1 min.		
Pollution category (VDE 0110, IEC 664, IEC 255-5)		3 / C		
Overvoltage category (VDE 0110, IEC 664, IEC 255-5)		III / C		
Environmental testing (IEC 68-2-30)		24 h cycle time, 55 °C, 93 % rel., 96 h		

¹⁾ Open-circuit principle: Output relay energizes if the measured value exceeds/drops below the adjusted threshold.
 Closed-circuit principle: Output relay de-energizes if the measured value exceeds/drops below the adjusted threshold.

Contact protection relays

Product group picture

2



Contact protection relays

Table of contents

Contact protection relays	
Product group picture	125
Table of contents	126
Benefits, advantages and operating controls	127
Ordering details	128
Technical information	129
Technical data	130

Contact protection relays

Benefits and advantages, Operating controls

Characteristics CM-KRN

- Protects and reduces load from sensitive control contacts
- Adjustable ON-delay 0.05-30 s
- Acts as two-position switch
- Stores switch positions
- Electrically isolated circuits
- 2 c/o contacts
- 2 LEDs for status indication

2

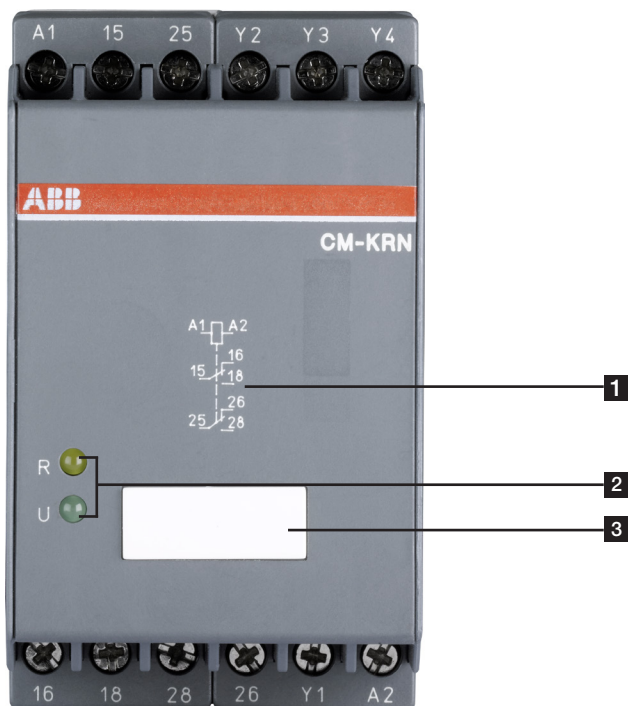

1 Connection diagram

2 Indication of operational states

R: yellow LED - relay status

U: green LED - control supply voltage

3 Marker label

Contact protection relays

Ordering details



CM-KRN

Description

Contact protection relay:

The CM-KRN protects sensitive control contacts from excessive load. It can be used with latching function or without. Bounce time of control contacts can be bypassed by the adjustable response delay time. Use for contact protection.

Ordering details

Rated control supply voltage	Timing circuit	Type	Order code	Price	Weight (1 pce) kg (lb)
24 V AC	0.05-30 s	CM-KRN	1SVR450089R0000		0.30 (0.66)
110-130 V AC			1SVR450080R0000		0.30 (0.66)
220-240 V AC			1SVR450081R0000		0.30 (0.66)
380-415 V AC			1SVR450082R0000		0.30 (0.66)
24 V AC			1SVR450099R0000		0.30 (0.66)
110-130 V AC			1SVR450090R0000		0.30 (0.66)
220-240 V AC			1SVR450091R0000		0.30 (0.66)
24 V AC/DC ¹⁾			1SVR450099R1000		0.30 (0.66)

¹⁾ Not electrically isolated

Contact protection relays

Technical information

2

Use for contact protection. The contact to be protected is connected to terminals Y1 and Y2. Use for contact protection with latching capacity. The output relay energizes after contact Y1-Y3 has been closed for at least 20 ms. It remains energized until contact Y1-Y4 closes. The switching positions are stored. The relay is suitable for load reduction purposes for devices with minimum and maximum contacts. The CM-KRN can be operated via 3-wire proximity sensors for switching of higher power. The supply circuit, the control circuit and the output circuit are electrically isolated against each other.

Function diagram - CM-KRN

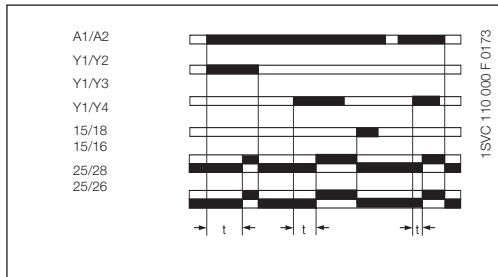

Connection diagram CM-KRN

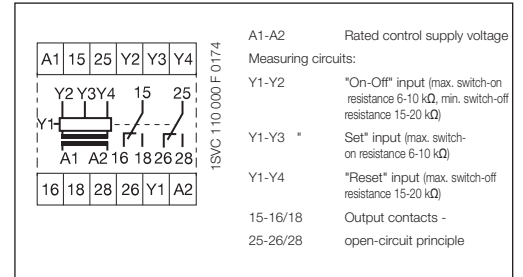

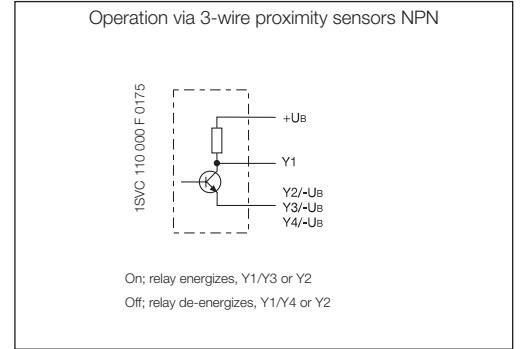
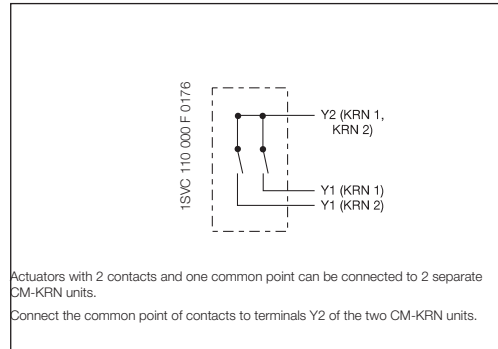

Use, applications



Contact protection relays

Technical data

Type	CM-KRN	
Supply circuit	A1-A2	
Rated control supply voltage U_g - power consumption	A1-A2	24 V AC - approx. 3.5 VA
	A1-A2	24 V AC/DC - approx. 3.5 VA
	A1-A2	110-130 V AC - approx. 3.5 VA
	A1-A2	220-240 V AC - approx. 3.5 VA
	A1-A2	380-415 V AC - approx. 3.5 VA
Rated control supply voltage U_g tolerance	-15...+10 %	
Rated frequency	50-60 Hz	
Duty time	100 %	
Timing circuit		
ON-delay time	0.05-1 s, 1.5-30 s	
OFF-delay time	max. 50 ms	
Measuring circuit / contact circuit	Y1-Y2/Y3/Y4	
Measuring input	contact protection without latching	Y1-Y2
	contact protection with latching	Y1-Y3/Y4
Threshold	Y1-Y2/Y3	6-10 k Ω
Threshold-Hysteresis	Y1-Y2/Y4	15-20 k Ω
No-load voltage at the measuring input	≤ 10 V DC	
Contact time for latching (CM-KRN without timing circuit)	min. 20 ms	
Switching current at the measuring input	3 mA	
Maximum applied voltage at the measuring input	$\leq \pm 30$ V (contact voltage)	
Indication of operational states		
Control supply voltage	U: green LED	 : control supply voltage applied
Relay status	R: yellow LED	 : output relay energized
Output circuit	15-16/18, 25-26/28	
Kind of output	relay, 2 c/o contacts	
Operating principle ¹⁾	open-circuit principle	
Rated operational voltage (VDE 0110, IEC 60947-5-1)	400 V	
Rated switching voltage	400 V AC	
Rated operational current I_g (IEC/EN 60947-5-1)	AC12 (resistive) 230 V	5 A
	AC15 (inductive) 230 V	3 A
	DC12 (resistive) 24 V	5 A
	DC13 (inductive) 24 V	2.5 A
AC rating (UL 508)	Utilization category (Control Circuit Rating Code)	B 300
	max. rated operational voltage	300 V AC
	max. continuous thermal current at B 300	5 A
	max. making/breaking apparent power at B 300	3600/360 VA
Mechanical lifetime	30×10^6 switching cycles	
Electrical lifetime (AC12, 230 V, 5 A)	0.1×10^6 switching cycles	
Max. fuse rating to achieve short-circuit protection	n/c / n/o contact	10 A fast-acting / 10 A fast-acting
General data		
Dimensions (W x H x D)	45 x 78 x 100 mm (1.77 x 3.07 x 3.94 in)	
Mounting position	any	
Degree of protection	enclosure / terminals	IP20 / IP50
Ambient temperature range	operation / storage	-25...+65 °C / -40...+85 °C
Mounting	DIN rail (IEC/EN 60715)	
Electrical connection		
Wire size	fine-strand with wire end ferrule	2 x 2.5 mm ² (2 x 14 AWG)
Standards		
Product standard	IEC 255-6, EN 60255-6	
Low Voltage Directive	2006/95/EC	
EMC Directive	2004/108/EC	
Electromagnetic compatibility		
Interference immunity to electrostatic discharge	IEC/EN 61000-4-2	6 kV / 8 kV
radiated, radio-frequency, electromagnetic field	IEC/EN 61000-4-3	10 V/m
electrical fast transient / burst	IEC/EN 61000-4-4	2 kV / 5 kHz
surge	IEC/EN 61000-4-5	2 kV symmetrical
conducted disturbances, induced by radio-frequency fields	IEC/EN 61000-4-6	10 V
Isolation data		
Rated insulation voltage (IEC 60947-1)	400 V	
Rated impulse withstand voltage U_{imp} (IEC 644-6)	4 kV	
Pollution category (IEC 255-5, IEC 664)	3	
Overvoltage category (IEC 255-5, IEC 664)	III	

¹⁾ Open-circuit principle: Output relay is energized if the measured value exceeds/drops below the adjusted threshold.

Sensor interface relays

Product group picture

2



Sensor interface relays

Table of contents

Sensor interface relays	
Product group picture	131
Table of contents	132
Benefits, advantages and operating controls	133
Ordering details	134
Technical information	135
Technical data	136

Sensor interface relays

Benefits and Advantages, Operating controls

Characteristics CM-SIS

2

- High efficiency
- Low heating
- Wide range of supply voltage
- Constant output voltage 24 V DC
- Protective separation acc. to EN 50178 (VDE 0160)
- Short-circuit and overload proof
- Input protected by internal fuse
- 2 x 1 c/o contact
- 3 LEDs for status indication

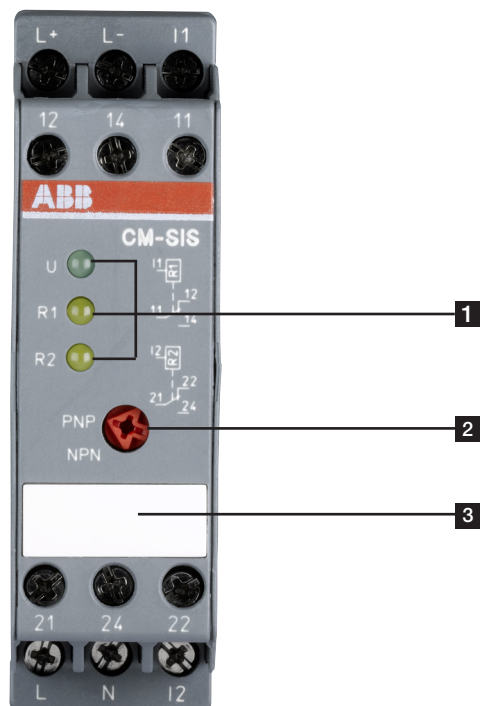

1 Indication of operational states

U: green LED - control supply voltage

R1: red LED - relay status R1

R2: red LED - relay status R2

2 Rotary switch for sensor type selection

3 Marker label

Sensor interface relays

Ordering details



CM-SIS

Description

Senior interface relay:

The CM-SIS is used to supply 2- or 3-wire NPN or PNP sensors with power and to evaluate their switching signals. Two sensors of the types NPN or PNP can be connected simultaneously. Selection is done via the front-face rotary switch.

Ordering details

Rated control supply voltage	Type	Order code	Price	Weight (1 pce) kg (lb)
110-240 V AC / 105-260 V DC ¹⁾	CM-SIS	1SVR430500R2300		0.22 (0.48)

¹⁾ Protective separation, short circuit and overload proof

Sensor interface relays

Technical information

2

The CM-SIS (terminals L+, L-) supplies the connected sensors with voltage (24 V DC), the maximum power supply current is 0.5 A. The supply voltage and the sensor inputs are electrically isolated from the supply circuit. To ensure maximum safety when using these sensors, the principle of protective separation has been included.

Each sensor input signal energizes the corresponding output relay without delay. The relay is energized as soon as a threshold current is exceeded at input I1 or I2. Sensor leakage currents of up to 8 mA don't affect the evaluation. The threshold value is about 9 mA. If the threshold value at input I1 or I2 is exceeded the corresponding relay R1 or R2 energizes and the corresponding LED lights up.

The wide-range supply voltage input of CM-SIS allows its application in nearly all supply systems.

The CM-SIS is also suitable for other applications, for example it is also possible to connect PTC or NTC resistors instead of PNP or NPN sensors or to operate the SIS directly by switching contacts.

Function diagram - CM-SIS

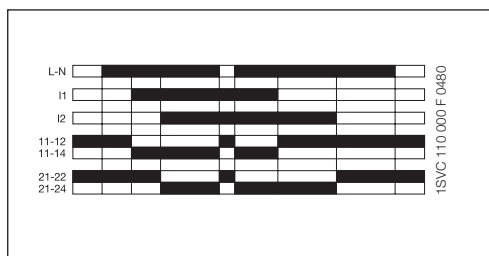

Connection diagram CM-SIS

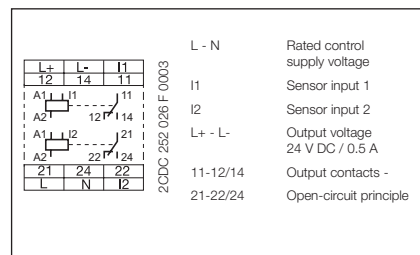

Connection of 2-wire sensors

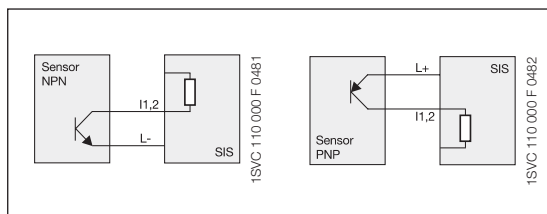

Connection of 3-wire sensors

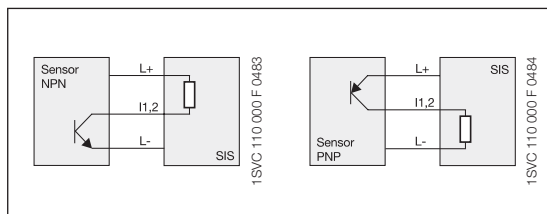

Sensor interface relays

Technical data

Type		CM-SIS
Input circuit		
Supply voltage	L-N AC	110-240 V AC (-15...+10 %)
	DC	110-240 V (max. 105-260 V DC)
Frequency, AC supply		47-440 Hz
Supply voltage failure bridging time		10 ms min. at 100 % load
Current consumption	max.	0.35 A
	at 115 V AC	0.27 A
	at 230 V AC	0.14 A
Inrush current at 25°C (≤ 2 ms)		33 A
Internal input fuse		800 mA slow-acting
Measuring circuit		L+, L- / I1, I2
Sensor voltage	L+ L-	24 V DC ± 3%
Sensor current / power		max. 0.5 A / 12 W
Residual ripple		max. 100 mV _{pp}
Deviation with	load change statical	max. ± 0.5 %
	load change dynamical 10-90 % change of the input voltage	max. .5 %
Short-circuit protection		overcurrent switch-off with automatic restart
Overload protection		excess temperature and overcurrent switch-off
Reset after thermal overload switch-off		automatic reset after cooling down
Sensor type connection possibilities	I1, I2	2- or 3-wire connection, NPN or PNP selectable by front-face switch
Input resistance		approx. 2.5 kΩ
Threshold value for relays R1, R2		$U_{\text{emitter, collector}} < 2,3 \text{ V}$ (I1, I2 > 8 mA)
Maximum switching frequency		approx. 20 Hz
Output circuit		11-12/14, 21-22/24
Kind of output		2 relays, 1 c/o contact each
Operating principle		open-circuit principle ¹⁾
Rated operational voltage		250 V
Maximum switching voltage		250 V AC
Rated operational current I _B (IEC/EN 60947-5-1)	AC12 (resistive) 230 V	4 A
	AC15 (inductive) 230 V	3 A
	DC12 (resistive) 24 V	4 A
	DC13 (inductive) 24 V	2 A
AC rating (UL 508)	Utilization category (Control Circuit Rating Code)	B 300
	max. rated operational voltage	300 V AC
	max. continuous thermal current at B 300	5 A
	max. making/breaking apparent power at B 300	3600/360 VA
Mechanical lifetime		10 x 10 ⁶ switching cycles
Electrical lifetime		0.1 x 10 ⁶ switching cycles
Max. fuse rating to achieve short-circuit protection	n/c / n/o contact	6 A fast-acting / 10 A fast-acting
Indication of operational states		
Control supply voltage	U: green LED	: control supply voltage applied
Relay status R1	R1: yellow LED	: threshold value at input I1 exceeded
Relay status R2	R2: yellow LED	: threshold value at input I2 exceeded
General data		
Efficiency at rated load		approx. 84 % (at 230 V AC)
Ambient temperature range	operation / storage	0...+55 °C / -25...+75 °C
Dimensions (W x H x D)		22.5 x 78 x 100 mm (0.89 x 3.07 x 3.94 in)
Mounting position		horizontally
Mounting		DIN rail (IEC/EN 60715)
Minimum distance to other units		left-hand side 10 mm (0.39 in), vertical distance 50 mm (1.97 in)
Electrical connection		
Wire size		2 x 2,5 mm ² (2 x 14 AWG)
Standards		
Product standard		IEC 255-6, EN 60255-6
Electrical safety		IEC(EN) 60255-5, EN 50178 (VDE 0160), EN60950, UL 508, CSA 22.2
Electrical isolation		protective separation between L+,L-, I1,I2, and L,N,I1,I2,I4,I21,I22,I24
Electromagnetic compatibility		
Interference immunity to electrostatic discharge	IEC/EN 61000-4-2	EN 61000-6-2 Level 3 (6 / 8 kV)
radiated, radio-frequency, electromagnetic field	IEC/EN 61000-4-3	Level 3 (10 V/m)
electrical fast transient / burst surge	IEC/EN 61000-4-4	Level 4 (4 kV)
conducted disturbances, induced by radio-frequency fields	IEC/EN 61000-4-5	Inst. class 3 (2 kV)
Interference immunity to Input current harmonics	IEC/EN 61000-4-6	Level 3 (10 V)
	EN 50081-2	radiated noise EN 55011, class B
		no limitation
Isolation data		
Insulation testing		2.5 kV AC (routine test), 3 kV AC (type test)
Degree of pollution		2
Overvoltage category		II

¹⁾ Open-circuit principle: Output relay is energized if the measured value exceeds/drops below the adjusted threshold.

Cycle monitoring relay with watchdog function

Product group picture

2



Cycle monitoring relay with watchdog function

Table of contents

Cycle monitoring relay with watchdog function	
Product group picture	137
Table of contents	138
Benefits, advantages and operating controls	139
Ordering details	140
Technical information	141
Technical data	142

Cycle monitoring relay with watchdog function

Benefits and Advantages, Operating controls

Characteristics

2

- Cycle monitor for monitoring the function of programmable logic controllers or industrial pcs
- 4 selectable cycle monitoring time ranges from 0.5 to 1000 ms
- 24 V DC supply
- 1 c/o contact
- 2 LEDs for status indication

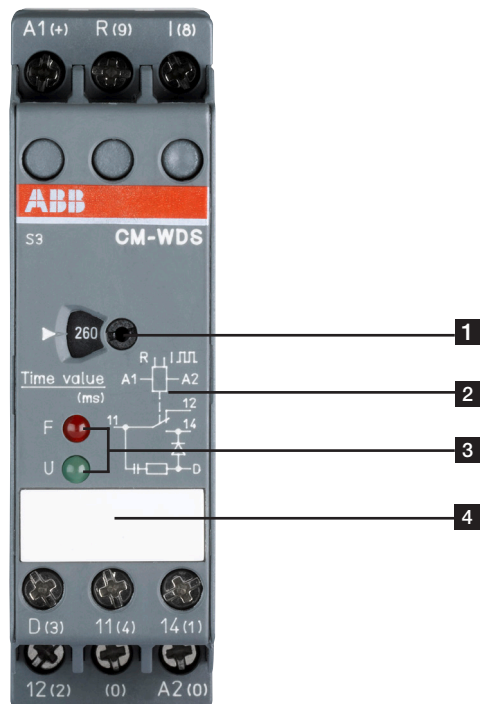

- 1 Setting the lower threshold value of cycle monitoring time
- 2 Connection diagram
- 3 Indication of operational states
F: red LED - cycle error
U: green LED - control supply voltage
- 4 Marker label

Cycle monitoring relay with watchdog function

Ordering details

Description

The cycle monitoring relay CM-WDS (watchdog) observes if a regularly intermittent pulse is applied to its pulse input "I". It is, for example, possible to connect the output of a programmable logic controller (plc), which is set and reset regularly (e. g. once each cycle). The connected cycle pulse must be generated by suitable programming of the plc/ipc. Now, the CM-WDS monitors if the cycle time of the plc/ipc program is smaller than the cycle monitoring time set by means of the front-face selector switch "time value (ms)".

The output relay 11-12/14 of the CM-WDS energizes and the red LED is switched off, if there are minimum 8 successive regular pulses on input "I". When the pulse signal stays out or is not regular, the output relay de-energizes and the red LED is illuminated.

In case the monitoring time is too short or too long, this can be adjusted by a modified programming of the plc/ips or by modified setting of the monitoring time "time value (ms)".

A fault recognized and stored with the CM-WDS can be reset by an H-impulse (0-1-transition) on the reset input "R(9)", so that the cycle monitoring is again released. The reset impulse can be generated by means of a reset button or by suitable programming of the controller (plc/ipc).



2CDC 251 011 S0012

CM-WDS

Ordering details

Rated control supply voltage	Type	Order code	Price 1 pce	Weight (1 pce) kg (lb)
24 V DC	CM-WDS	1SVR430896R000		0.15 (0.33)

Cycle monitoring relay with watchdog function

Technical information

2

Function diagram - CM-WDS

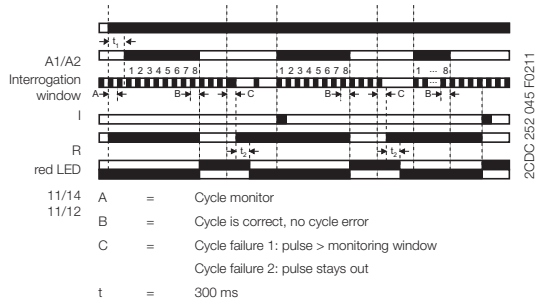

Connection diagram CM-WDS

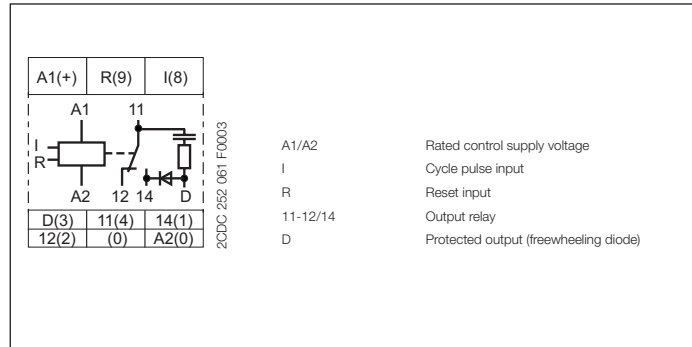

Example of application - circuit diagram

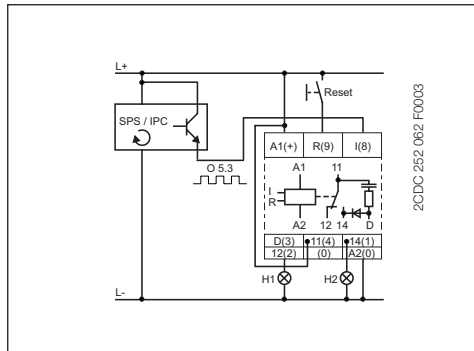

Application

The CM-WDS is designed for the external monitoring of the correct function of programmable logic controllers (plc) and industrial pcs (ipc).

Cycle monitoring relay with watchdog function

Technical data

Type	CM-WDS	
Input circuit	A1-A2	
Rated control supply voltage U_s - power consumption	24 V DC - approx. 1 W	
Tolerance of the rated control supply voltage U_s	-30 % - +30 %	
Duty time	100 %	
Measuring circuit	I	
Monitoring function	cycle monitoring	
Measuring voltage	24 V DC	
Current consumption at the measuring input	approx. 5 mA	
Setting range of cycle monitoring time	selectable: 0.5-150 ms, 0.5-260 ms, 0.5-500 ms, 0.5-1000 ms	
Response time	approx. 0.5-1000 ms	
Accuracy within the supply voltage tolerance	$\Delta U \leq 0.5 \%$	
Accuracy within the temperature range	$\Delta U \leq 0.06 \%$ / °C	
Timing circuit		
ON-delay	approx. 2.2-10 s	
Indication of operational states		
Control supply voltage	U: green LED	
Output relay de-energized / cycle error	F: red LED	
Output circuit	11-12/14	
Kind of output	1 c/o	
Operating principle	Closed-circuit principle ¹⁾	
Contact material	AgCdo	
Rated operational voltage U_o	IEC/EN 60947-1	250 V
Minimum switching voltage / Minimum switching current	250 V AC, 250 V DC	
Maximum switching voltage	250 V AC, 250 V DC	
Rated operational current I_o (IEC/EN 60947-5-1)	AC12 (resistive) 230 V	4 A
	AC15 (inductive) 230 V	3 A
	DC12 (resistive) 24 V	4 A
	DC13 (inductive) 24 V	2 A
AC rating (UL 508)	Utilization category (Control Circuit Rating Code)	B 300
	max. rated operational voltage	300 V AC
	max. continuous thermal current at B 300	5 A
	max. making/breaking apparent power at B 300	3600/360 VA
Mechanical lifetime	10 x 10 ⁶ switching cycles	
Electrical lifetime (AC12, 230 V, 4 A)	0.1 x 10 ⁶ switching cycles	
Max. fuse rating to achieve short-circuit protection	n/c / n/o contacts	10 A fast-acting / 10 A fast-acting
General data		
Dimensions (W x H x D)	22.5 x 78 x 100 mm (0.89 x 3.07 x 3.94 in)	
Mounting position	any	
Degree of protection	enclosure / terminals	IP50 / IP20
Ambient temperature range	operation / storage	-20...+60 °C / -40...+85 °C
Mounting	DIN rail (IEC/EN 60715)	
Electrical connection		
Wire size	fine-strand with wire end ferrule	2 x 2.5 mm ² (2 x 14 AWG)
Standards		
Product standard	IEC 255-6, EN 60255-6	
Low Voltage Directive	2006/95/EC	
EMC Directive	2004/108/EC	
Operational reliability (IEC 68-2-6)	4 g	
Mechanical shock resistance (IEC 68-2-6)	6 g	
Electromagnetic compatibility		
Interference immunity to electrostatic discharge	IEC/EN 61000-4-2	EN 61000-6-2 Level 3 (6 kV / 8 kV)
radiated, radio-frequency, electromagnetic field	IEC/EN 61000-4-3	Level 3 (10 V/m)
electrical fast transient / burst	IEC/EN 61000-4-4	Level 3 (2 kV / 5 kHz)
surge	IEC/EN 61000-4-5	Level 3 (2 kV L-L)
conducted disturbances, induced by radio-frequency fields	IEC/EN 61000-4-6	Level 3 (10 V)
Interference emission	EN 61000-6-4	
Isolation data		
Rated insulation voltage between supply-, control- and output circuit (VDE 0110, IEC 60947-1)	250 V	
Rated impulse withstand between all isolated circuits (VDE 0110, IEC 664)	4 kV / 1.2-50 μ s	
Test voltage between all isolated circuits	2.5 kV, 50 Hz, 1 min	
Pollution degree (VDE 0110, IEC 664, IEC 255-5)	3/C	
Overvoltage category (VDE 0110, IEC 664, IEC 255-5)	III	
Environmental tests (IEC 68-2-30)	24 h cycle, 55 °C, 93 % rel. 96 h	

¹⁾ Closed-circuit principle: Output relay de-energizes if a cycle error occurs

General technical data, Accessories, Current transformers

Table of contents

General technical data, Accessories, Current transformers	
Table of contents	144
Technical diagrams - CM-range	145
Dimensional drawings	147
Ordering details - CM-range accessories	149

General technical data, Accessories, Current transformers

Technical diagrams - CM-range

Load limit curves

CM-S (22.5 mm), CM-E (22.5 mm), CM-UFD.M22

AC load (resistive)

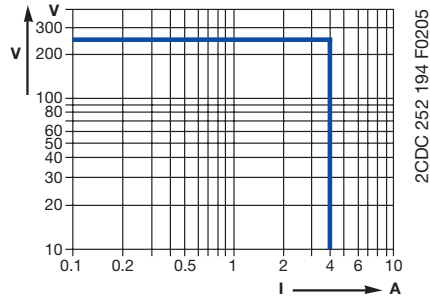

DC load (resistive)

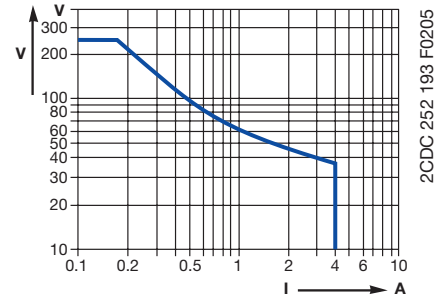

Derating factor F for inductive AC load

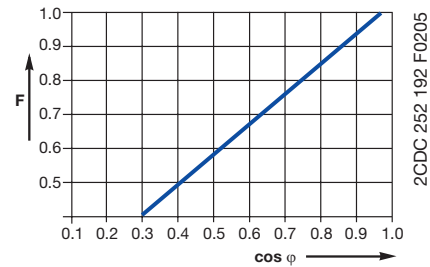

Contact lifetime

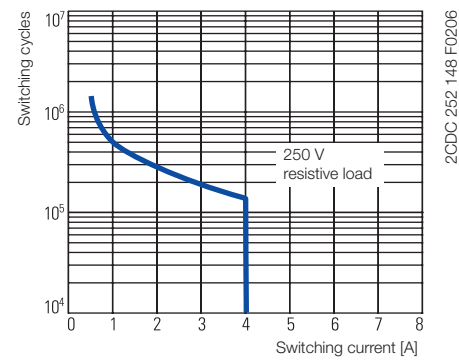

CM-N (45 mm)

AC load (resistive)

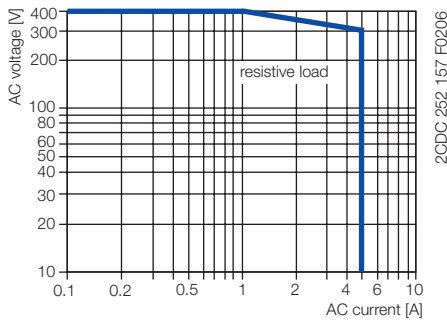

DC load (resistive)

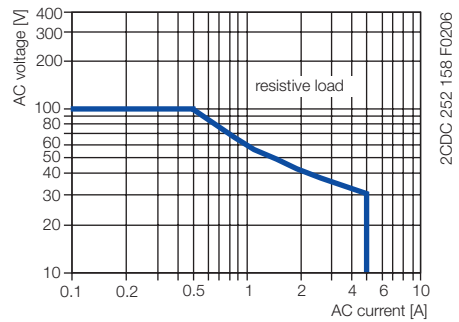

Derating factor F for inductive AC load

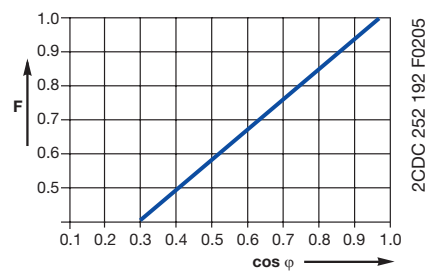

Contact lifetime

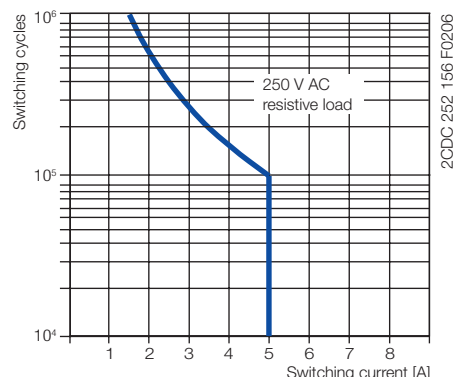

General technical data, Accessories, Current transformers

Technical diagrams - CM-range

Load limit curves CM-UFD.M21

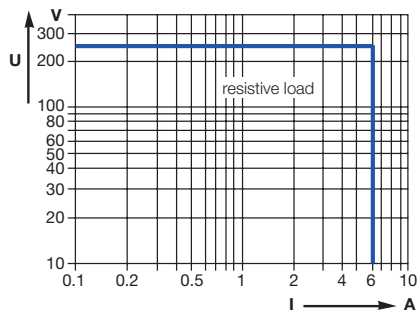

2CDC 252 010 F0212

AC load (resistive)

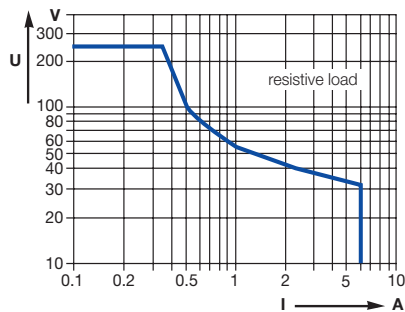

2CDC 252 011 F0212

DC load (resistive)

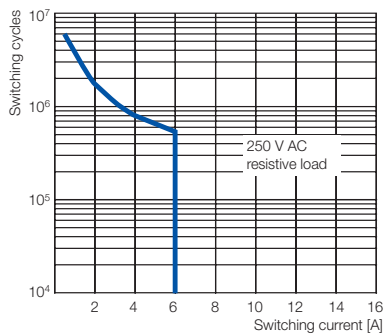

2CDC 252 012 F0212

Contact lifetime

General technical data, Accessories, Current transformers

Dimensional drawings

Measuring and monitoring relays CM range old housing

Dimensions in mm

2

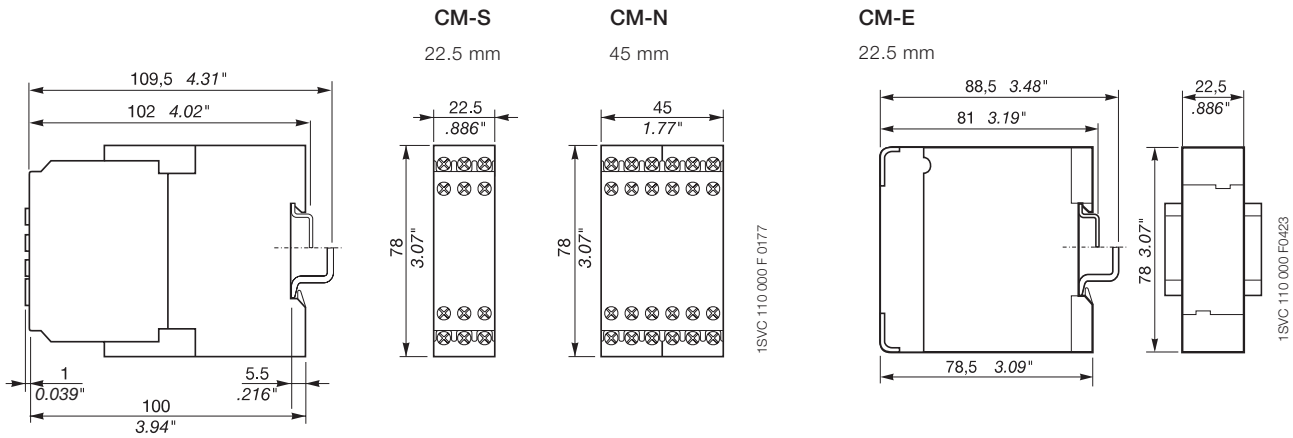

Measuring and monitoring relays CM range new housing

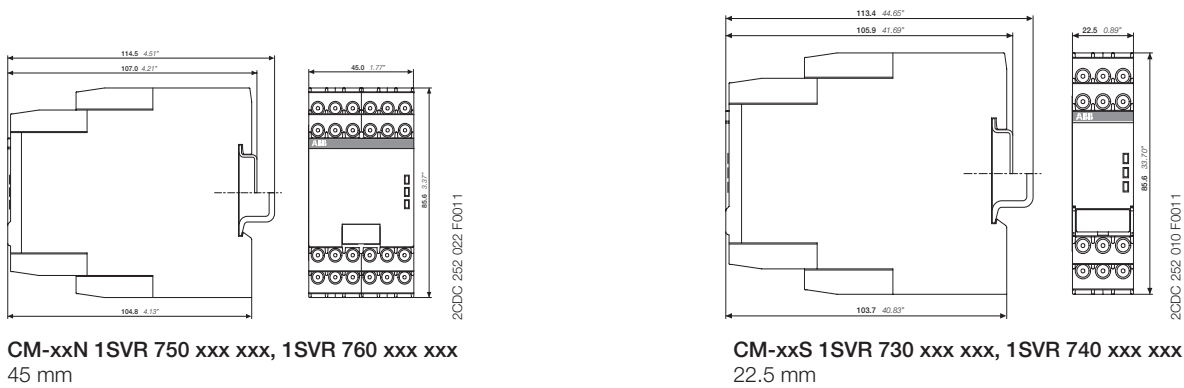

Temperature monitoring relays

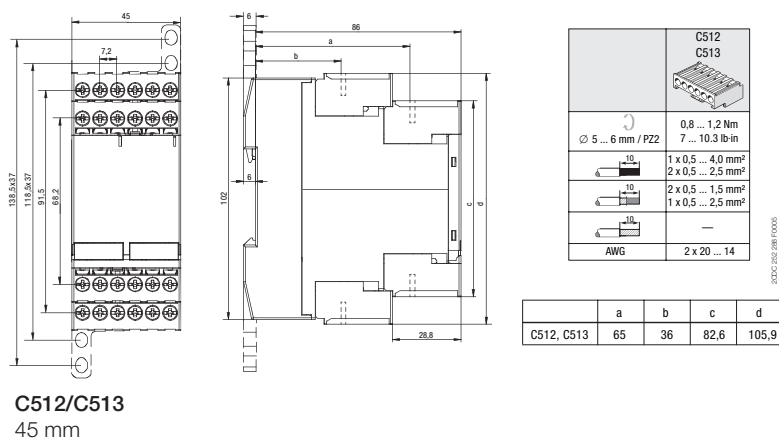

General technical data, Accessories, Current transformers

Dimensional drawings

Dimensional drawing CM-UFD.M21

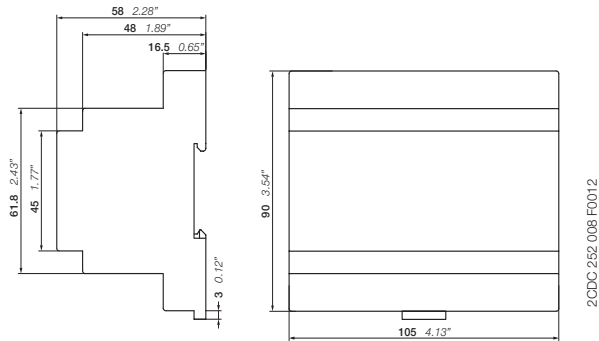

Dimensional drawing CM-UFD.M22

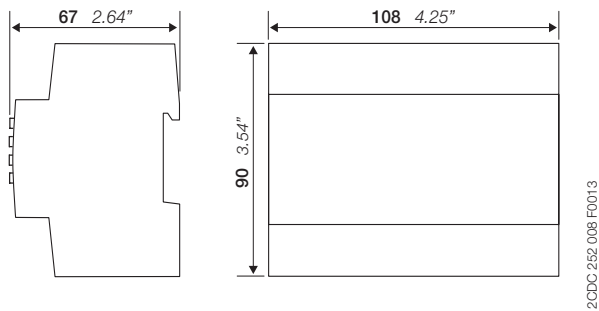

General technical data, Accessories, Current transformers

Ordering details - CM-range accessories

2

Accessories

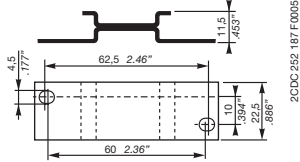

ADP.01

2CDC 252 187 F0005



MAR.01

2CDC 252 186 F0005

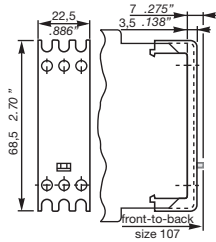

Sealable cover
COV.01

2CDC 252 186 F0005

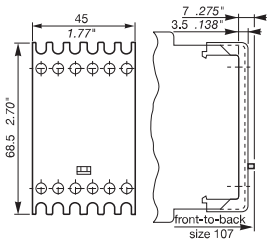

Sealable cover
COV.02

1SVC 110 000 F 0190

Ordering details

Description	For type	Width in mm	for devices	Type	Order code	Price pce	Pkg qty	Weight (1 pce) g (oz)
Adapter for screw mounting	CM-S CM-S.S/P	22.5		ADP.01	1SVR430029R0100		1	18.4 (0.65)
	CM-N CM-N.S/P	45		ADP.02	1SVR440029R0100		1	36.7 (1.30)
Marker label	CM-S, CM-N CM-S.S/P CM-N.S/P		without DIP switches	MAR.01	1SVR366017R0100		10	0.19 (0.007)
	CM-S, CM-N		with DIP switches	MAR.02	1SVR430043R0000		10	0.13 (0.005)
	CM-S.S/P CM-N.S/P		with DIP switches	MAR.12	1SVR730006R0000		10	0.152 (0.335)
Sealable transparent cover	CM-S	22.5		COV.01	1SVR430005R0100		1	5.2 (0.18)
	CM-N	45		COV.02	1SVR440005R0100		1	7.7 (0.27)
	CM-S.S/P	22.5		COV.11	1SVR730005R0100		1	4.0 (0.129)
	CM-N.S/P	45		COV.12	1SVR750005R0100		1	7 (0.247)

General technical data, Accessories, Current transformers

Ordering details - CM-range accessories

2CDC 251 002 F0005

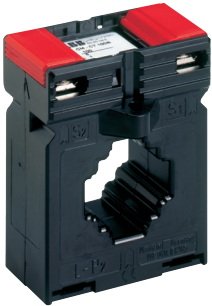

CM-CT

Plug-in current transformers CM-CT

Without primary conductor though with foot angle, insulating protective cap and bar fastening screws
 Primary / rated current from 50 A to 600 A
 Secondary current of 1 A or 5 A
 Class 1

Ordering details

Rated primary current	Secondary current	Burden class	Type	Order code	Price pce	Weight (1 pce) g (oz)
50 A	1 A	1 VA / 1	CM-CT 50/1	1SVR450116R1000		0.31 (0.683)
75 A		1.5 VA / 1	CM-CT 75/1	1SVR450116R1100		0.31 (0.683)
100 A		2.5 VA / 1	CM-CT 100/1	1SVR450116R1200		0.276 (0.608)
150 A		2.5 VA / 1	CM-CT 150/1	1SVR450116R1300		0.32 (0.705)
200 A		2.5 VA / 1	CM-CT 200/1	1SVR450116R1400		0.222 (0.489)
300 A		5 VA / 1	CM-CT 300/1	1SVR450117R1100		0.29 (0.639)
400 A	5 A	5 VA / 1	CM-CT 400/1	1SVR450117R1200		0.27 (0.595)
500 A		5 VA / 1	CM-CT 500/1	1SVR450117R1300		0.29 (0.639)
600 A		5 VA / 1	CM-CT 600/1	1SVR450117R1400		0.24 (0.529)
50 A		1 VA / 1	CM-CT 50/5	1SVR450116R5000		0.3 (0.661)
75 A		1.5 VA / 1	CM-CT 75/5	1SVR450116R5100		0.31 (0.683)
100 A		2.5 VA / 1	CM-CT 100/5	1SVR450116R5200		0.31 (0.683)
150 A	5 A	2.5 VA / 1	CM-CT 150/5	1SVR450116R5300		0.28 (0.617)
200 A		5 VA / 1	CM-CT 200/5	1SVR450116R5400		0.29 (0.639)
300 A		5 VA / 1	CM-CT 300/5	1SVR450117R5100		0.252 (0.556)
400 A		5 VA / 1	CM-CT 400/5	1SVR450117R5200		0.26 (0.573)
500 A		5 VA / 1	CM-CT 500/5	1SVR450117R5300		0.208 (0.459)
600 A		5 VA / 1	CM-CT 600/5	1SVR450117R5400		0.21 (0.463)

2CDC 251 003 F0005



CM-CT with mounted accessories

Ordering details - Accessories

Description	Type	Order code	Price 10 pces	Weight (1 pce) g (oz)
Snap-on fastener for DIN rail mounting of CM-CT	CM-CT A	1SVR450118R1000		0.009 (0.02)

2CDC 251 159 F0006



CM-CT-A mounted on DIN rail

Operating principle / circuit diagram

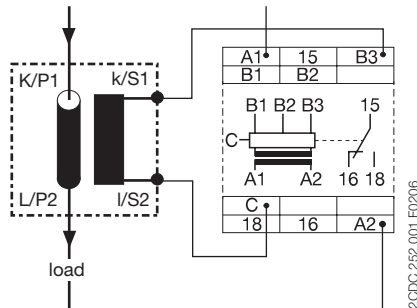

Dimensional drawing

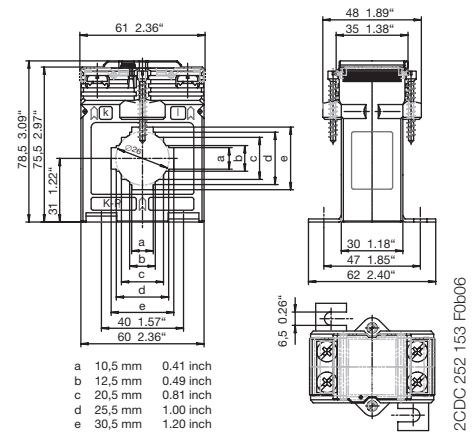

Primary switch mode power supplies

Product group picture

3



Primary switch mode power supplies

Table of contents

Primary switch mode power supplies	
Table of contents	3/2
Overview	3/3
Approvals and marks	3/4
Selection table - Single-phase	3/5
Selection table - Three-phase, CP-ASI	3/6
CP-D range	3/7
Table of contents	3/8
Benefits and advantages	3/9
Ordering details	3/10
Technical data	3/11
Technical diagrams	3/15
Dimensional drawings	3/16
CP-E range	3/17
Table of contents	3/18
Benefits and advantages	3/19
Ordering details	3/20
Technical data	3/21
Technical diagrams, Wiring instructions	3/29
Technical diagrams, Dimensional drawings	3/30
CP-T range	3/31
Table of contents	3/32
Benefits and advantages	3/33
Ordering details	3/34
Technical data	3/35
Technical diagrams, Dimensional drawings	3/39
Technical diagrams	3/40
CP-S and CP-C	3/41
Table of contents	3/42
Benefits and advantages	3/43
Operating control	3/44
Ordering details	3/45
Technical data	3/46
Technical diagrams, Dimensional drawings	3/50
Redundancy units	3/51
Ordering details	3/51
Technical data	3/52
Dimensional drawings	3/56
CP-ASI range	3/57
Table of contents	3/58
Benefits and advantages	3/59
Ordering details	3/60
Technical data	3/61
Technical diagrams	3/63
Dimensional drawings	3/64
CP-B range	3/65
Table of contents	3/66
Benefits and advantages	3/67
Ordering details	3/68
Technical data	3/69
Technical data, Technical diagrams	3/70
Dimensional drawings	3/71
Electronic protection devices EPD24	3/73

Primary switch mode power supplies

Overview

Modern power supply units are a vital component in most areas of energy management and automation technology. ABB as your global partner in these areas pays the utmost attention to the resulting requirements. Innovation is the key to a substantial enlargement of our power supply product program:

CP-D

The CP-D range of power supply units in MDRC design (modular DIN rail components) fits into all domestic installation and distribution panels.

CP-E

The CP-E range offers enhanced functionality while the number of different types has been considerably reduced. Now all power supply units can be operated at an ambient temperature of up to +70 °C.

CP-T

The CP-T range of three-phase power supply units is ABB's youngest member of the power supply family.

CP-S

The CP-S range is ABB's standard range, a high-end power supply unit optimised for serial applications.

CP-C

The CP-C range's pluggable function modules adapt these power supply units exactly to your application's needs. Of course, all ABB power supply units feature primary switch mode technology – environmentally sound and cost-efficiency. This represents the highest level of innovative industrial electronics.

Application manual

For today's applications, e.g. in control engineering, it is essential to make the right decision regarding the selection and planning of the power supply unit. Incorrect dimensioning or incorrect connection of a power supply unit can seriously affect the safety and/or availability of the entire installation.

ABB's "Power Supply Units" application manual provides a general overview of switch mode power supply units, thus helping you to choose the ideal power supply unit and avoid problems during engineering and commissioning. The manual generally shows and explains the fundamental

characteristics of and the differences between power supply units, and provides a detailed introduction to the ABB product range on the basis of the selection criteria. Finally, it describes and explains application examples for engineering.

The manual is available in English and German.

English Version: 2CDC 114 048 M0203

German Version: 2CDC 114 048 M0103

Primary switch mode power supplies

Approvals and marks

		CP-D						
		CP-D 12/0.83	CP-D 12/2.1	CP-D 24/0.42	CP-D 24/1.3	CP-D 24/2.5	CP-D 24/4.2	CP-D RU
Approvals								
	UL 508, CAN/CSA C22.2 No.107.1	■ ¹⁾	■ ¹⁾	■ ¹⁾	■ ¹⁾	■ ¹⁾	■ ¹⁾	
	UL 1310, CAN/CSA C22.2 No.223 (Class 2 Power Supply)	■ ¹⁾	■ ¹⁾	■ ¹⁾	■ ¹⁾	■ ¹⁾		
	UL 60950, CAN/CSA C22.2 No.60950	■ ¹⁾	■ ¹⁾	■ ¹⁾	■ ¹⁾	■ ¹⁾	■ ¹⁾	
	GOST	■ ²⁾	■ ²⁾	■ ²⁾	■ ²⁾	■ ²⁾	■ ²⁾	
	CCC	■ ¹⁾	■ ¹⁾	■ ¹⁾	■ ¹⁾	■ ¹⁾	■ ¹⁾	
Marks								
	CE	■	■	■	■	■	■	■
	C-Tick	□	□	□	□	□	□	

		CP-E												CP-T									
		CP-E 5/3.0	CP-E 12/2.5	CP-E 12/10.0	CP-E 24/0.75	CP-E 24/1.25	CP-E 24/2.5	CP-E 24/5.0	CP-E 24/10.0	CP-E 24/20.0	CP-E 48/0.62	CP-E 48/1.25	CP-E 48/5.0	CP-E 48/10.0	CP-RUD	CP-T 24/5.0	CP-T 24/10.0	CP-T 24/20.0	CP-T 24/40.0	CP-T 48/5.0	CP-T 48/10.0	CP-T 48/20.0	
Approvals																							
	UL 508, CAN/CSA C22.2 No.107.1	■ ¹⁾	■ ¹⁾	■ ¹⁾	■ ¹⁾	■ ¹⁾	■ ¹⁾	■ ¹⁾	■ ¹⁾	■ ¹⁾	■ ¹⁾	■ ¹⁾	■ ¹⁾	■ ¹⁾		■ ¹⁾	■ ¹⁾	■ ¹⁾	■ ¹⁾	■ ¹⁾	■ ¹⁾	■ ¹⁾	■ ¹⁾
	UL 1310, CAN/CSA C22.2 No.223 (Class 2 Power Supply)	■	■		■	■	■				■	■									■	■	■
	ANSI/ISA-12.12 (Class I, Div. 2, hazardous locations) CAN/CSA C22.2 No. 213	■	■	■	■	■	■	■	■	■	■	■	■	■		■	■	■	■	■	■	■	■
	UL 60950, CAN/CSA C22.2 No.60950	■ ¹⁾	■ ¹⁾	■ ¹⁾	■ ¹⁾	■ ¹⁾	■ ¹⁾	■ ¹⁾	■ ¹⁾	■ ¹⁾	■ ¹⁾	■ ¹⁾	■ ¹⁾	■ ¹⁾		■ ¹⁾	■ ¹⁾	■ ¹⁾	■ ¹⁾	■ ¹⁾	■ ¹⁾	■ ¹⁾	■ ¹⁾
	GOST	■ ²⁾	■ ²⁾	■ ²⁾	■ ²⁾	■ ²⁾	■ ²⁾	■ ²⁾	■ ²⁾	■ ²⁾	■ ²⁾	■ ²⁾	■ ²⁾	■ ²⁾		■ ²⁾	■ ²⁾	■ ²⁾	■ ²⁾	■ ²⁾	■ ²⁾	■ ²⁾	■ ²⁾
	CCC	■ ¹⁾	■ ¹⁾	■ ¹⁾	■ ¹⁾	■ ¹⁾	■ ¹⁾	■ ¹⁾	■ ¹⁾	■ ¹⁾	■ ¹⁾	■ ¹⁾	■ ¹⁾	■ ¹⁾									
	GB4943, GB9254, GB17625.1															■	■	■	■	■	■	■	■
Marks																							
	CE	■	■	■	■	■	■	■	■	■	■	■	■	■	■	■	■	■	■	■	■	■	■
	C-Tick	■	■	■	■	■	■	■	■	■	■	■	■	■	■	□	□	□	□	□	□	□	□

		CP-S			CP-C				CP-A		CP-B			
		CP-S 24/5.0	CP-S 24/10.0	CP-S 24/20.0	CP-C 24/5.0	CP-C 24/10.0	CP-C 24/20.0	CP-C MM	CP-A RU	CP-A CM	CP-B 24/3.0	CP-B 24/10.0	CP-B 24/20.0	CP-B EXT.2
Approvals														
	UL 508, CAN/CSA C22.2 No.107.1	■ ¹⁾	■ ¹⁾	■ ¹⁾	■ ¹⁾	■ ¹⁾	■ ¹⁾				■	■	■	■
	UL 1604 (Class I, Div. 2, hazardous locations), CAN/CSA C22.2 No.213	■ ¹⁾	■ ¹⁾	■ ¹⁾	■ ¹⁾	■ ¹⁾	■ ¹⁾							
	UL 60950, CAN/CSA C22.2 No.60950	■ ¹⁾	■ ¹⁾	■ ¹⁾	■ ¹⁾	■ ¹⁾	■ ¹⁾		■ ¹⁾	■ ¹⁾				
	GOST	■ ²⁾	■ ²⁾	■ ²⁾	■ ²⁾	■ ²⁾	■ ²⁾	■ ²⁾	■ ²⁾	■ ²⁾	■ ²⁾	■ ²⁾	■ ²⁾	■ ²⁾
	CB scheme	■	■	■	■	■	■		■	■				
Marks														
	CE	■	■	■	■	■	■	■	■	■	■	■	■	■
	C-Tick	■	■	■	■	■	■	■	■	□				

¹⁾ Approvals refer to the rated input voltage U_{in}.
²⁾ May have been replaced by EAC during the availability of this catalog edition.

Primary switch mode power supplies

Selection table - Single-phase

3

		Order number	1SVR 427 041 R1000	1SVR 427 043 R1200	1SVR 427 041 R0000	1SVR 427 043 R0100	1SVR 427 044 R0200	1SVR 427 045 R0400	1SVR 427 033 R3000	1SVR 427 032 R1000	1SVR 427 035 R1000	1SVR 427 030 R0000	1SVR 427 031 R0000	1SVR 427 032 R0000	1SVR 427 034 R0000	1SVR 427 035 R0000	1SVR 427 036 R0000	1SVR 427 030 R2000	1SVR 427 031 R2000	1SVR 427 034 R0000	1SVR 427 035 R2000	1SVR 427 014 R0000	1SVR 427 015 R0100	1SVR 427 016 R0100	1SVR 427 024 R0000	1SVR 427 025 R0000	1SVR 427 026 R0000	
			Single phase																									
			CP-D						CP-E												CP-S			CP-C				
Rated output voltage	5 VDC																											
	12 VDC		■	■					■		■																	
	24 VDC				■	■	■	■				■	■	■	■	■	■						■	■	■	■	■	■
	48 VDC																	■	■	■	■							
Rated output current	0.42 A				■																							
	0.625 A																		■									
	0.75 A											■																
	0.83 A		■																									
	1.25 A												■															
	1.3 A					■																						
	2.1 A			■																								
	2.5 A						■				■				■													
	3 A								■																			
	4.2 A							■																				
	5 A														■						■			■		■		
	10 A											■				■							■			■		
	20 A																■							■			■	
	Rated output power	10 W		■		■																						
15 W									■																			
18 W																												
30 W				■		■				■									■									
60 W							■																					
100 W								■																				
120 W												■											■			■		
240 W															■								■			■		
480 W																■									■		■	
Rated input voltage	100 - 240 V AC		■	■	■	■	■	■	■	■	■	■	■	■	■	■	■	■	■	■	■	■	■	■	■	■	■	■
	115/230 V AC auto select																											
	115 - 230 V AC																											
	110 - 240 V AC																						■			■	■	■
	110 - 120 V AC																											
220 - 240 V AC																												
DC input voltage range	120 - 370 V DC		■	■	■	■	■	■	■			■																
	90 - 375 V DC									■																		
	210 - 370 V DC										■				■													
	100 - 350 V DC																						■			■	■	■
220 - 350 V DC																												
Features	Power reserve design																						■	■	■	■	■	■
	Adjustable output voltage			■		■	■	■	■	■	■	■	■	■	■	■	■	■	■	■	■	■	■	■	■	■	■	■
	Integrated input fuse		■	■	■	■	■	■	■	■	■	■	■	■	■	■	■	■	■	■	■	■	■	■	■	■	■	■
	Short circuit stable		■	■	■	■	■	■	■	■	■	■	■	■	■	■	■	■	■	■	■	■	■	■	■	■	■	■
	Fold forward behavior (U/I)		■	■	■	■	■	■	■	■	■	■	■	■	■	■	■	■	■	■	■	■	■	■	■	■	■	■
	Fold back behavior (hiccup)								■			■																
	Power factor correction																											
	Ambient temp. rating -25°C (-40°C) to 70°C		■	■	■	■	■	■	■	■	■	■	■	■	■	■	■	■	■	■	■	■	■	■	■	■	■	■
	Parallel connection								■	■	3	■	■	■	■	3	3	3	■	■	■	■	3	3	5	5	5	5
	Serial connection		■	■	■	■	■	■	■	■	2	■	■	■	■	2	2	2	■	■	■	■	2	2	■	■	■	■

Primary switch mode power supplies

Selection table - Three-phase, CP-ASI

		Order number												
		1SVR 427 054 R0000	1SVR 427 055 R0000	1SVR 427 056 R0000	1SVR 427 057 R0000	1SVR 427 054 R2000	1SVR 427 055 R2000	1SVR 427 056 R2000						
		Three phase							AS-Interface					
		CP-T							CP-ASI					
Rated output voltage	24 V DC	■	■	■	■									
	30.5 V DC								■	■	■	■		
	48 V DC					■	■	■						
Rated output current	2.8 A								■					
	3 A									■	■			
	5 A	■				■								
	8 A													■
	10 A		■				■							
	20 A			■				■						
	40 A				■									
Rated output power	85 W								■					
	120 W	■												
	122 W									■	■			
	240 W		■			■								
	244 W													■
	480 W			■			■							
	960 W				■			■						
Rated input voltage	85-132 V AC, 184-264 V AC								■	■		■		
	3 x 400 - 800 V AC	■	■	■	■	■	■	■						
DC input voltage range	18-32.4 V DC													■
	480 - 820 V DC	■	■	■	■	■	■	■						
Features	Adjustable output voltage	■	■	■	■	■	■	■						
	Integrated input fuse	■	■	■	■	■	■	■						
	Short circuit stable	■	■	■	■	■	■	■						
	Fold forward behavior (U/I)	■	■	■	■	■	■	■						
	Fold back behavior (hiccup)	■	■	■	■	■	■	■						
	Power factor correction													
	Ambient temp. rating -25°C (-40°C) to 70°C	■	■	■	■	■	■	■						
	Serial connection		2	2	2	2	2	2						
	Suited for AS-Interfaces									■	■	■	■	

CP-D range

Product group picture

3



CP-D range

Table of contents

CP-D range	
Product group picture	3/7
Table of contents	3/8
Benefits and advantages	3/9
Ordering details	3/10
Technical data	3/11
Technical diagrams	3/15
Dimensional drawings	3/16

CP-D range

Benefits and advantages

Characteristics

- Output voltages 12 V, 24 V DC
 - Adjustable output voltages (devices > 10 W)
 - Output currents 0.42 A / 0.83 A / 1.3 A / 2.1 A / 2.5 A / 4.2 A
 - Power range 10 W, 30 W, 60 W, 100 W
 - Wide range input 100-240 V AC (90-264 V AC, 120-375 V DC)
 - High efficiency of up to 89 %
 - Low power dissipation and low heating
 - Free convection cooling (no forced cooling with ventilators)
 - Ambient temperature range during operation -40 °C...+70 °C
 - Open-circuit, overload and short-circuit stable
 - Integrated input fuse
 - U/I characteristic (fold-forward behaviour at overload – no switch-off)
 - LEDs for status indication
 - Light-grey housing in RAL 7035
- Approvals / Marks
(depending on device, partly pending):



Benefits

Width and structural form ①

With their width between 18 to 90 mm only, the CP-D range switch mode power supplies are ideally suited for installation in distribution panels.

Wide range input ②

Optimised for world-wide applications: The CP-D power supplies can be supplied with 90-264 V AC or 120-375 V DC.

Adjustable output voltage ③

The CP-D range types > 10 W feature a continuously adjustable output voltage. Thus, they can be optimally adapted to the application, e.g. compensating the voltage drop caused by a long line length.

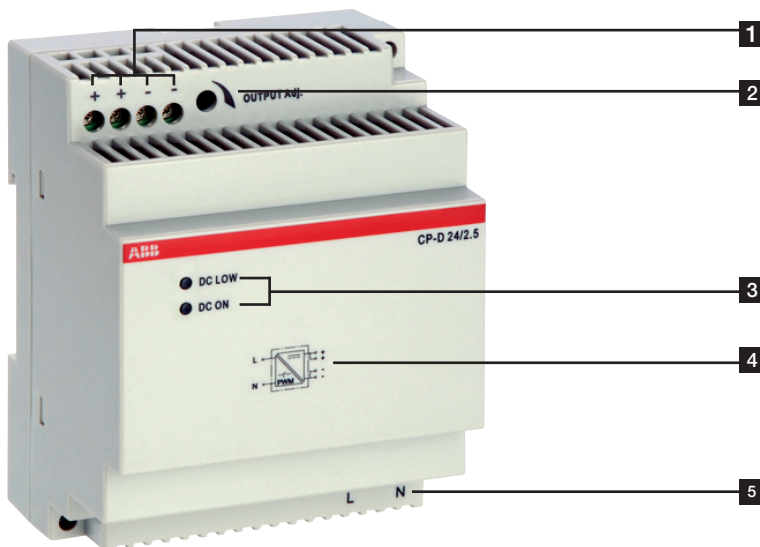
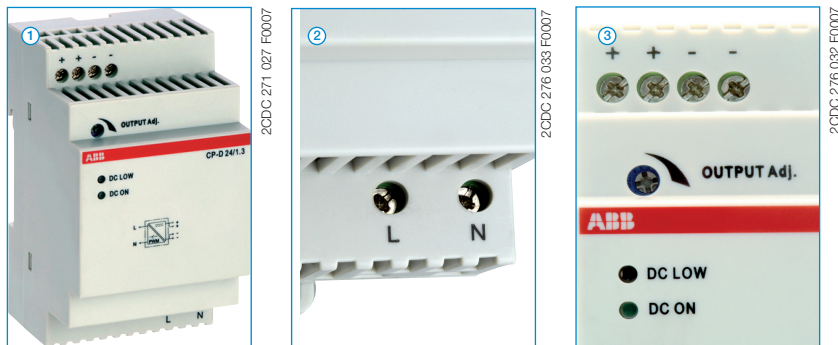

- 1** OUTPUT ++/--: terminals - output
- 2** INPUT L, N: terminals - input
- 3** Indication of operational states
DC ON: green LED - output voltage applied
DC LOW: red LED - output voltage too low
- 4** Circuit diagram
- 5** OUTPUT Adjust: potentiometer - adjustment of output voltage

CP-D range

Ordering details



CP-D 12/0.83, CP-D 24/0.42



CP-D 12/2.1, CP-D 24/1.3



CP-D 24/2.5

Description

The CP-D range of modular power supply units in MDRC design (modular DIN rail components) is ideally suited for installation in distribution panels. This range offers devices with output voltages of 12 V DC and 24 V DC at output currents of 0.42 A to 4.2 A. Thanks to a high thermal efficiency corresponding to low power and heat dissipation, the devices can be operated without forced cooling. All devices feature the U/I output characteristic (fold forward behaviour). All power supply units in the CP-D range are approved according to all relevant international standards.

Ordering details

Input voltage range	Rated output voltage / current	Type	Order code	Price 1 pce	Weight (1 pce) kg (lb)
90-264 V AC/ 120-375 V DC	12 V DC / 0.83 A	CP-D 12/0.83	1SVR427041R1000		0.06 (0.13)
90-264 V AC/ 120-375 V DC	12 V DC / 2.1 A	CP-D 12/2.1	1SVR427043R1200		0.19 (0.41)
90-264 V AC/ 120-375 V DC	24 V DC / 0.42 A	CP-D 24/0.42	1SVR427041R0000		0.06 (0.13)
90-264 V AC/ 120-375 V DC	24 V DC / 1.3 A	CP-D 24/1.3	1SVR427043R0100		0.19 (0.41)
90-264 V AC/ 120-375 V DC	24 V DC / 2.5 A	CP-D 24/2.5	1SVR427044R0200		0.25 (0.56)
90-264 V AC/ 120-375 V DC	24 V DC / 4.2 A	CP-D 24/4.2	1SVR427045R0400		0.32 (0.71)

CP-D range

Technical data

Data at $T_a = 25\text{ °C}$, $U_{in} = 230\text{ V AC}$ and rated values, unless otherwise indicated

Type	CP-D 12/0.83	CP-D 12/2.1
Input circuit - supply circuit		
	L, N	
Rated input voltage U_{in}	100-240 V AC	
Input voltage range	90-264 V AC / 120-375 V DC	
Frequency range AC	47-63 Hz	
Typical input current / typical power consumption	at 110 V AC	200 mA / 12.68 W
	at 230 V AC	128.3 mA / 13.01 W
Inrush current limiting	at 230 V AC	30 A (max. 3 ms)
Power failure buffering time	min. 30 ms	
Internal input fuse	1 A slow-acting / 250 V AC	2 A slow-acting / 250 V AC
Power factor correction (PFC)	no	
Indication of operational states		
Output voltage	DC ON: green LED	□: output voltage applied
	DC LOW: red LED	□: output voltage too low
Output circuit		
	+, -	++, --
Rated output voltage	12 V DC	
Tolerance of the output voltage	±1 %	
Adjustment range of the output voltage	-	12-14 V DC
Rated output power	10 W	30 W
Rated output current I_r	$T_a \leq 60\text{ °C}$	0.83 A
	$60\text{ °C} < T_a \leq 70\text{ °C}$	2.5 %/°C
Derating of the output current	load change statical	max. 1 %
	change of output voltage within the input voltage range	max. 1 %
Control time	< 1 ms	
Starting time after applying the supply voltage	at I_r	1000 ms
Rise time	at rated load	typ. 1 ms
Residual ripple and switching peaks	BW = 20 MHz	50 mV
Parallel connection	yes, using CP-D RU	
Series connection	yes, to increase voltage	
Resistance to reverse feed	18 V / 1 s	
Output circuit - No-load, overload and short-circuit behaviour		
Characteristic curve of output	U/I characteristic curve	
Short-circuit protection	continuous short-circuit stability	
Short-circuit behaviour	continuation with output power limiting	
Current limiting at short circuit	typ. 1.4 A	typ. 5.9 A
Overload protection	output power limiting	
Overvoltage protection	15-16.5 V DC	
No-load protection	continuous no-load stability	
Starting of capacitive loads	unlimited	
General data		
Efficiency	typ. 78 %	typ. 82 %
Duty time	100 %	
Dimensions (W x H x D)	18 x 91 x 57.5 mm	53 x 91 x 57.5 mm
	(0.71 x 3.58 x 2.26 in)	(2.09 x 3.58 x 2.26 in)
Weight	0.066 kg (0.13 lb)	0.196 kg (0.41 lb)
Material of housing	plastic	
Mounting	DIN rail (IEC/EN 60715), snap-on mounting without any tool	
Mounting position	horizontal	
Minimum distance to other units	horizontal / vertical	25 mm / 25 mm (0.98 in / 0.98 in)
Degree of protection	housing / terminals	IP20 / IP20
Protection class	II	

CP-D range

Technical data

Data at $T_a = 25\text{ °C}$, $U_n = 230\text{ V AC}$ and rated values, unless otherwise indicated

Type		CP-D 12/0.83	CP-D 12/2.1
Electrical connection - Input circuit / Output circuit			
Wire size	fine-strand with wire end ferrule	0.2-1.5 mm ² (24-16 AWG)	0.2-2.5 mm ² (24-14 AWG)
	rigid	0.2-2.5 mm ² (26-12 AWG)	0.2-2.5 mm ² (24-12 AWG)
Stripping length		4-5 mm (0.16-0.2 in)	7 mm (0.28 in)
Tightening torque		0.6 Nm (5 lb.in)	0.7 Nm (6 lb.in)
Environmental data			
Ambient temperature range	operation	-40...+70 °C	
	rated load	-40...+60 °C	
	storage	-40...+85 °C	
Damp heat (cyclic) (IEC/EN 60068-2-30)		4 x 24 cycles, 40 °C, 95 % RH	
Vibration (sinusoidal) (IEC/EN 60068-2-6)		50 m/s ² , 10 Hz - 2 kHz	
Shock (half-sine) (IEC/EN 60068-2-27)		40 m/s ² , 22 ms	
Isolation data			
Rated insulation voltage U_i	input circuit / output circuit	3 kV AC	
Pollution degree		2	
Overvoltage category (UL/IEC/EN 60950-1)		II	
Standards			
Product standard		EN 61204	
Low Voltage Directive		2006/95/EC	
EMC Directive		2004/108/EC	
Electrical safety		UL 508, UL 60950-1, EN 60950-1	
Protective low voltage		SELV (EN 60950-1)	
Electromagnetic compatibility			
Interference immunity to		EN 61000-6-2	
electrostatic discharge	IEC/EN 61000-4-2	Level 4 (4 kV / 8 kV)	Level 4 (4 kV / 15 kV)
radiated, radio-frequency, electromagnetic field	IEC/EN 61000-4-3	Level 3 (10 V/m)	
electrical fast transient/burst	IEC/EN 61000-4-4	Level 4 (4 kV)	
surge	IEC/EN 61000-4-5	Level 3 (2 kV L-L)	
conducted disturbances, induced by radio-frequency fields	IEC/EN 61000-4-6	Level 3 (10 V)	
Interference emission		EN 61000-6-3	
high-frequency radiated	IEC/CISPR 22, EN 55022	Class B	
high-frequency conducted	IEC/CISPR 22, EN 55022	Class B	

„Approvals and marks“ on page 3/4.

CP-D range

Technical data

Data at $T_a = 25\text{ }^\circ\text{C}$, $U_{in} = 230\text{ V AC}$ and rated values, unless otherwise indicated

Type	CP-D 24/0.42	CP-D 24/1.3	CP-D 24/2.5	CP-D 24/4.2	
Input circuit - supply circuit					
	L, N				
Rated input voltage U_{in}	100-240 V AC				
Input voltage range	90-264 V AC / 120-375 V DC				
Frequency range AC	47-63 Hz				
Typical input current / typical power consumption	at 110 V AC	184 mA / 11.62 W	600 mA / 37.92 W	1120 mA / 69.3 W	1800 mA / 117.3 W
	at 230 V AC	120.6 mA / 12 W	344 mA / 38.16 W	660 mA / 70.1 W	900 mA / 114.4 W
Inrush current limiting	at 230 V AC		30 A (max. 3 ms)	50 A (max. 3 ms)	60 A (max. 3 ms)
Power failure buffering time			min. 30 ms	min. 60 ms	
Internal input fuse	1 A slow-acting / 250 V AC		2 A slow-acting / 250 V AC		3.15 A slow-acting / 250 V AC
Power factor correction (PFC)	no				
Indication of operational states					
Output voltage	DC ON: green LED	[]: output voltage applied			
	DC LOW: red LED	[]: output voltage too low			
Output circuit					
	+, -		++, --		
Rated output voltage	24 V DC				
Tolerance of the output voltage	$\pm 1\%$				
Adjustment range of the output voltage	-		24-28 V DC		
Rated output power	10 W	30 W	60 W	100 W	
Rated output current I_o	$T_a \leq 60\text{ }^\circ\text{C}$: 0.42 A	$T_a \leq 60\text{ }^\circ\text{C}$: 1.3 A	$T_a \leq 55\text{ }^\circ\text{C}$: 2.5 A	$T_a \leq 60\text{ }^\circ\text{C}$: 4.2 A	
Derating of the output current	$60\text{ }^\circ\text{C} < T_a \leq 70\text{ }^\circ\text{C}$: 2.5 %/ $^\circ\text{C}$	$60\text{ }^\circ\text{C} < T_a \leq 70\text{ }^\circ\text{C}$: 2.5 %/ $^\circ\text{C}$	$55\text{ }^\circ\text{C} < T_a \leq 70\text{ }^\circ\text{C}$: 2.5 %/ $^\circ\text{C}$	$60\text{ }^\circ\text{C} < T_a \leq 70\text{ }^\circ\text{C}$: 2.5 %/ $^\circ\text{C}$	
	Maximum load change statical deviation with change of output voltage within the input voltage range	max. 1 %			
Control time	< 1 ms				
Starting time after applying the supply voltage	at I_o 1000 ms				
Rise time	at rated load typ. 1 ms				
Residual ripple and switching peaks	BW = 20 MHz 50 mV				
Parallel connection	yes, using CP-D RU				
Series connection	yes, to increase voltage				
Resistance to reverse feed	35 V / 1 s				
Output circuit - No-load, overload and short-circuit behaviour					
Characteristic curve of output	U/I characteristic curve				
Short-circuit protection	continuous short-circuit stability				
Short-circuit behaviour	continuation with output power limiting				
Current limiting at short circuit	typ. 0.78 A	typ. 4.2 A	typ. 6.05 A	typ. 11.5 A	
Overload protection	output power limiting				
Overvoltage protection	30-33 V DC				
No-load protection	continuous no-load stability				
Starting of capacitive loads	unlimited				
General data					
Efficiency	typ. 80 %	typ. 83 %	typ. 86 %	typ. 89 %	
Duty time	100 %				
Dimensions (W x H x D)	18 x 91 x 57.5 mm	53 x 91 x 57.5 mm	71 x 91 x 57.5 mm	89.9 x 91 x 57.5 mm	
	(0.71 x 3.58 x 2.26 in)	(2.09 x 3.58 x 2.26 in)	(2.80 x 3.58 x 2.26 in)	(3.54 x 3.58 x 2.26 in)	
Weight	0.066 kg (0.13 lb)	0.196 kg (0.41 lb)	0.252 kg (0.55 lb)	0.386 kg / (0.72 lb)	
Material of housing	plastic				
Mounting	DIN rail (IEC/EN 60715), snap-on mounting without any tool				
Mounting position	horizontal				
Minimum distance to other units	horizontal / vertical		25 mm / 25 mm (0.98 in / 0.98 in)		
Degree of protection	housing / terminals		IP20 / IP20		
Protection class	II				

CP-D range

Technical data

Data at $T_a = 25\text{ °C}$, $U_n = 230\text{ V AC}$ and rated values, unless otherwise indicated

Type	CP-D 24/0.42	CP-D 24/1.3	CP-D 24/2.5	CP-D 24/4.2
Electrical connection - Input circuit / Output circuit				
Wire size	fine-strand with wire end ferrule	0.2-1.5 mm ² (24-16 AWG)	0.2-2.5 mm ² (24-14 AWG)	
	rigid	0.2-2.5 mm ² (26-12 AWG)	0.2-2.5 mm ² (24-12 AWG)	
Stripping length	4-5 mm (0.16-0.2 in)		7 mm (0.28 in)	
Tightening torque	0.6 Nm (5 lb.in)		0.7 Nm (6 lb.in)	
Environmental data				
Ambient temperature range	operation	-40...+70 °C		
	rated load	-40...+60 °C	-40...+55 °C	-40...+60 °C
	storage	-40...+85 °C		
Damp heat (cyclic) (IEC/EN 60068-2-30)	4 x 24 cycles, 40 °C, 95 % RH			
Vibration (sinusoidal) (IEC/EN 60068-2-6)	50 m/s ² , 10 Hz - 2 kHz			
Shock (half-sine) (IEC/EN 60068-2-27)	40 m/s ² , 22 ms			
Isolation data				
Rated insulation voltage U_i	input circuit / output circuit	3 kV AC	4 kV AC	3 kV AC
Pollution degree	2			
Overvoltage category (UL/IEC/EN 60950-1)	II			
Standards				
Product standard	EN 61204			
Low Voltage Directive	2006/95/EC			
EMC Directive	2004/108/EC			
Electrical safety	UL 508, UL 60950-1, EN 60950-1			
Protective low voltage	SELV (EN 60950-1)			
Electromagnetic compatibility				
Interference immunity to	EN 61000-6-2			
electrostatic discharge	IEC/EN 61000-4-2	Level 4 (4 kV / 8 kV)	Level 4 (4 kV / 15 kV)	Level 4 (4 kV / 8 kV)
		radiated, radio-frequency, electromagnetic field		
radiated, radio-frequency, electromagnetic field	IEC/EN 61000-4-3	Level 3 (10 V/m)		
electrical fast transient/burst	IEC/EN 61000-4-4	Level 4 (4 kV)		
surge	IEC/EN 61000-4-5	Level 3 (2 kV L-L)		
conducted disturbances, induced by radio-frequency fields	IEC/EN 61000-4-6	Level 3 (10 V)		
Interference emission	EN 61000-6-3			
high-frequency radiated	IEC/CISPR 22, EN 55022	Class B		
high-frequency conducted	IEC/CISPR 22, EN 55022	Class B		

„Approvals and marks“ on page 3/4.

CP-D range

Technical diagrams

3

Characteristic curve of output at $T_a = 25\text{ }^\circ\text{C}$

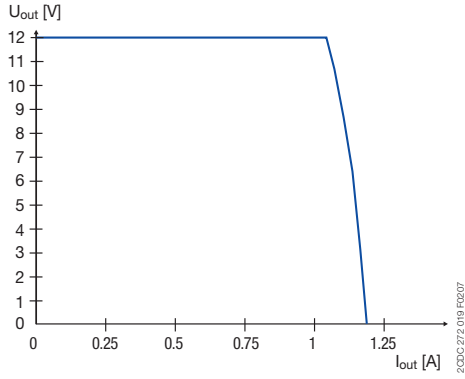

CP-D 12/0.83

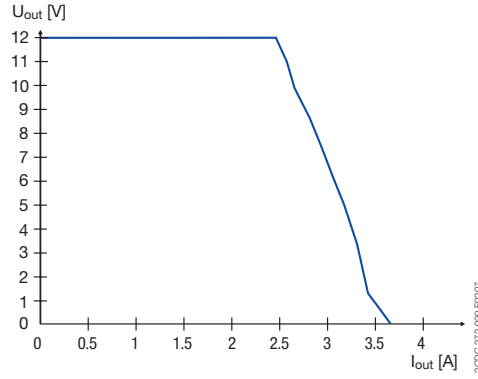

CP-D 12/2.1

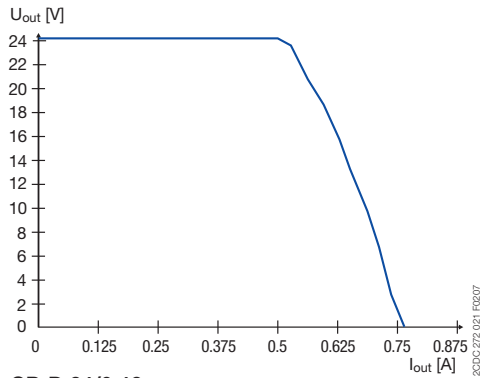

CP-D 24/0.42

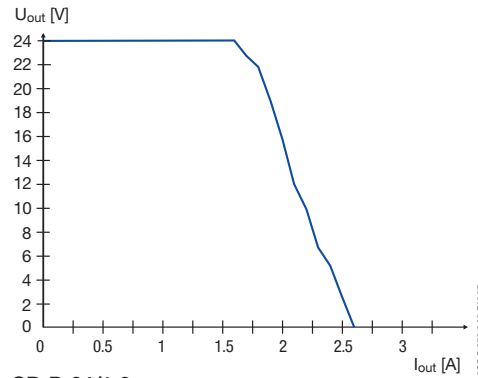

CP-D 24/1.3

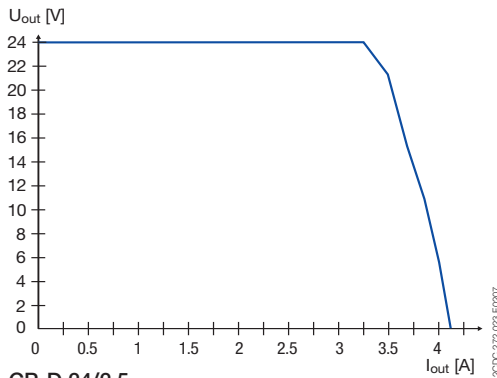

CP-D 24/2.5

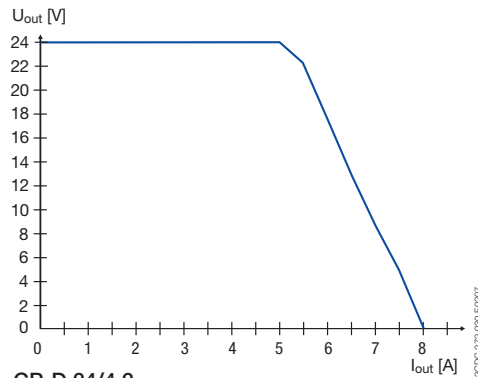

CP-D 24/4.2

Characteristic curve of temperature at rated output voltage

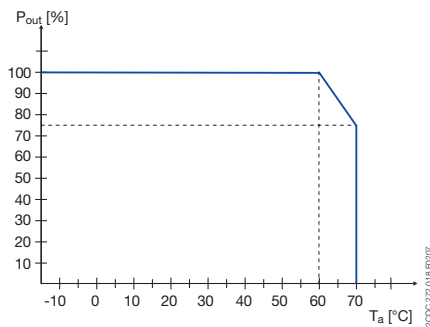

CP-D except CP-D 24/2.5

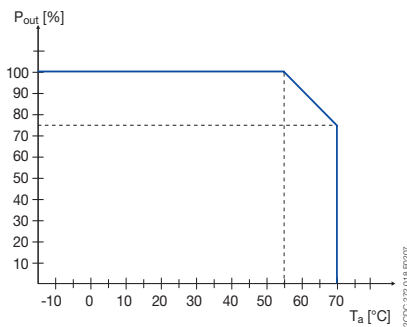

CP-D 24/2.5

CP-D range

Dimensional drawings

Dimensional drawings

dimensions in mm

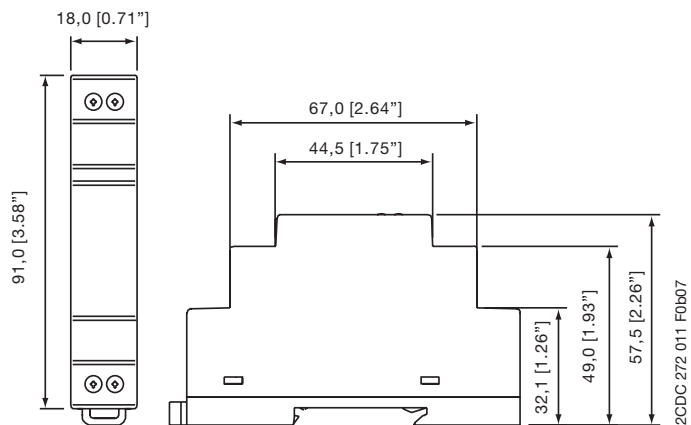

CP-D 12/0.83, CP-D 24/0.42

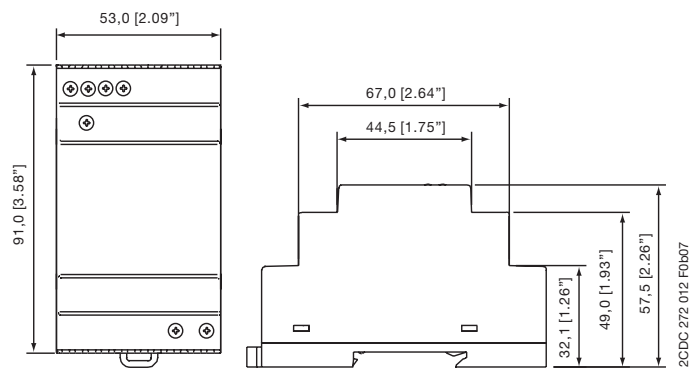

CP-D 12/2.1, CP-D 24/1.3

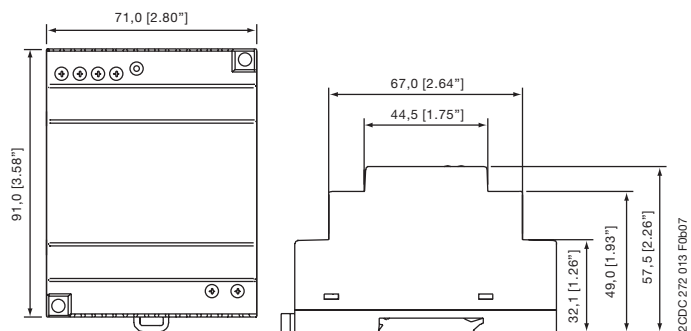

CP-D 24/2.5

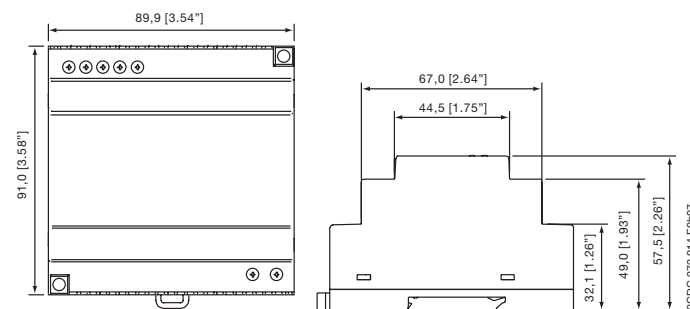

CP-D 24/4.2

CP-E range Product group picture

3



CP-E range

Table of contents

CP-E range	
Product group picture	3/17
Table of contents	3/18
Benefits and advantages	3/19
Ordering details	3/20
Technical data	3/21
Technical diagrams, Wiring instructions	3/29
Technical diagrams, Dimensional drawings	3/30

CP-E range

Benefits and advantages

3

Characteristics

- Output voltages 5 V, 12 V, 24 V, 48 V DC
- Adjustable output voltages
- Output currents 0.625 A / 0.75 A / 1.25 A / 2.5 A / 3 A / 5 A / 10 A / 20 A
- Power range 15 W, 18 W, 30 W, 60 W, 120 W, 240 W, 480 W
- High efficiency of up to 90 %
- Low power dissipation and low heating
- Free convection cooling (no forced cooling with ventilators)
- Ambient temperature range during operation -40...+70 °C
- Open-circuit, overload and short-circuit stable
- Integrated input fuse
- U/I characteristic curve on devices > 18 W (fold-forward behaviour at overload – no switch-off)
- Redundancy units offering true redundancy
- LED(s) for status indication
- Signalling output/contact for output voltage OK
Transistor on 24 V devices > 18 W and < 120 W
Solid-state on 24 V devices \geq 120 W
- Approvals / Marks
(depending on device, partly pending):



Benefits

Signalling output/contact ①

The CP-E range 24 V devices > 18 W offer an output/contact for monitoring of the output voltage and remote diagnosis.

Wide range input ②

Optimised for world-wide applications: The CP-E power supplies can be supplied within a wide range of AC or DC voltage.

Adjustable output voltage ③

The CP-E range types feature a continuously adjustable output voltage. Thus, they can be optimally adapted to the application, e.g. compensating the voltage drop caused by a long line length.

Redundancy units ④

For decoupling of parallelized power supply units \leq 40 V. Thus, true redundancy can be achieved.

Further information about redundancy unit on page 51.

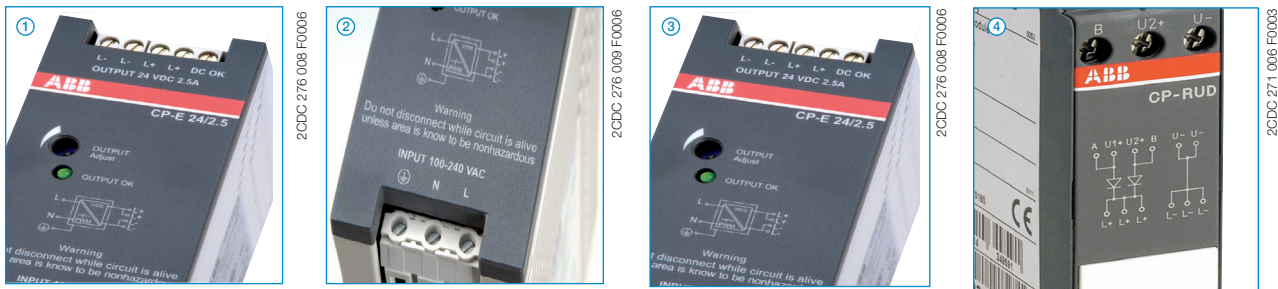

- 1** INPUT L, N, PE: terminals - input
- 2** Circuit diagram
- 3** single/parallel: sliding switch - adjustment of single or parallel operation
- 4** Indication of operational states
DC ON: green LED - green LED - output voltage OK
DC LOW: red LED - output voltage too low
- 5** OUTPUT L+, L+, L-, L-: terminals - output
- 6** OUTPUT Adjust: potentiometer - adjustment of output voltage

CP-E range

Ordering details

Description

This range offers types with output voltages from 5 V DC to 48 V DC at output currents of 0.625 A to 20 A. The high thermal efficiency of up to 90 %, corresponding to very low power and heat dissipation, allows operation without forced cooling. The functionality has been enhanced while the number of different types has been considerably reduced.

Of course all power supplies of the CP-E range are approved in accordance with all relevant international standards.

Ordering details - CP-E < 100 W

Input voltage range	Rated output voltage / current	Type	Order code	Price 1 pce	Weight (1 pce) kg (lb)
90-264 V AC / 120-375 V DC	5 V DC / 3 A	CP-E 5/3.0	1SVR427033R3000		0.15 (0.33)
85-264 V AC / 90-375 V DC	12 V DC / 2.5 A	CP-E 12/2.5	1SVR427032R1000		0.29 (0.64)
90-132 V AC, 180-264 V AC / 210-375 V DC	12 V DC / 10 A	CP-E 12/10.0	1SVR427035R1000		1.00 (2.20)
90-264 V AC / 120-375 V DC	24 V DC / 0.75 A	CP-E 24/0.75	1SVR427030R0000		0.15 (0.33)
85-264 V AC / 90-375 V DC	24 V DC / 1.25 A	CP-E 24/1.25	1SVR427031R0000		0.29 (0.64)
85-264 V AC / 90-375 V DC	24 V DC / 2.5 A	CP-E 24/2.5	1SVR427032R0000		0.36 (0.79)



2CDC 271 017 F0008

CP-E 24/0.75



2CDC 271 013 F0008

CP-E 12/2.5



2CDC 271 028 F0008

CP-E 48/5.0





Ordering details - CP-E ≥ 120 W

Input voltage range	Rated output voltage / current	Type	Order code	Price 1 pce	Weight (1 pce) kg (lb)
90-132 V AC, 180-264 V AC / 210-375 V DC	24 V DC / 5 A	CP-E 24/5.0	1SVR427034R0000		1.00 (2.20)
90-132 V AC, 180-264 V AC / 210-375 V DC	24 V DC / 10 A	CP-E 24/10.0	1SVR427035R0000		1.36 (3.01)
90-264 V AC / 120-375 V DC	24 V DC / 20 A	CP-E 24/20.0	1SVR427036R0000		1.90 (4.18)
85-264 V AC / 90-375 V DC	48 V DC / 0.625 A	CP-E 48/0.62	1SVR427030R2000		0.29 (0.64)
85-264 V AC / 90-375 V DC	48 V DC / 1.25 A	CP-E 48/1.25	1SVR427031R2000		0.36 (0.79)
90-132 V AC, 180-264 V AC / 210-375 V DC	48 V DC / 5 A	CP-E 48/5.0	1SVR427034R2000		1.36 (3.01)
90-264 V AC / 120-375 V DC	48 V DC / 10 A	CP-E 48/10.0	1SVR427035R2000		1.90 (4.19)

CP-E range

Technical data

Data at $T_a = 25\text{ °C}$, $U_{in} = 230\text{ V AC}$ and rated values, unless otherwise indicated

Type		CP-E 5/3.0	CP-E 12/2.5	CP-E 12/10.0
Input circuit				
Rated input voltage U_{in}		100-240 V AC	L, N	
Input voltage range		90-264 V AC / 120-375 V DC	85-264 V AC / 90-375 V DC	115 / 230 V AC auto select 90-132 V AC, 180-264 V AC / 210-375 V DC
Frequency range AC		47-63 Hz		
Typical input current	at 115 V AC at 230 V AC	335 mA 210 mA	560 mA 330 mA	2.2 A 0.83 A
Typical power consumption		19.8 W	35.9 W	143 W
Inrush current limiting	at 115 V AC at 230 V AC	10 A (max. 3 ms) 18 A (max. 3 ms)	20 A (max. 3 ms) 40 A (max. 3 ms)	24 A (max. 5 ms) 48 A (max. 5 ms)
Discharge current	input / output input / PE	0.25 mA 3.5 mA		
Power failure buffering time	at 115 V AC at 230 V AC	min. 20 ms min. 75 ms	min. 20 ms min. 30 ms	min. 25 ms min. 30 ms
Internal input fuse		2 A slow-acting / 250 V AC		3.15 A slow-acting / 250 V AC
Power factor correction (PFC)		no		yes, passive, 0.7
Indication of operational states				
Output voltage	green LED red LED	OK:  L: output voltage OK LOW:  L: output voltage too low	OUTPUT OK:  L: output voltage OK -	OUTPUT OK:  L: output voltage OK OUTPUT LOW:  L: output voltage too low
Output circuit				
Rated output voltage		5 V DC	L+, L-, L+, L+, L-, L-	
Tolerance of the output voltage		0...+1 %	12 V DC	
Adjustment range of the output voltage		4.5-5.75 V DC	12-14 V DC	11.4-14.5 V DC
Rated output power		15 W	30 W	120 W
Rated output current I_L	$T_a \leq 60\text{ °C}$	3.0 A	2.5 A	10 A
Derating of the output current	$60\text{ °C} < T_a \leq 70\text{ °C}$	2.5 %/°C	2.5 %/°C	
Maximum deviation with	load change statical	±2 %	±0.5 %	±1 % (single mode) ±5 % (parallel mode)
	change of output voltage within the input voltage range	±1 %	±0.5 %	±0.5 %
Control time		< 2 ms		
Starting time after applying the supply voltage	at I_L with 3500 µF with 7000 µF	max. 1 s - max. 1.5 s	max. 2 s -	- max. 1.5 s
Rise time	at rated load with 3500 µF with 7000 µF	max. 150 ms - max. 500 ms	max. 500 ms -	- max. 500 ms
Fall time		max. 150 ms		
Residual ripple and switching peaks	BW = 20 MHz	50 mV		
Parallel connection		yes, to enable redundancy		configurable, to increase power, up to 3 devices, min. 0.1 I_L - max. 0.9 I_L
Series connection		yes, to increase voltage		yes, to increase voltage, max. 2 devices
Resistance to reverse feed		1 s - max. 7.5 V DC	1 s - max. 18 V DC	max. 18 V DC
Output circuit - No-load, overload and short-circuit behaviour				
Characteristic curve of output		Hiccup-mode	U/I characteristic curve	
Short-circuit protection		continuous short-circuit proof		
Short-circuit behaviour		Hiccup-mode	continuation with output power limiting	
Overload protection		output power limiting		
No-load protection		continuous no-load stability		
Starting of capacitive loads		7000 µF	3500 µF	7000 µF

CP-E range

Technical data

Data at $T_a = 25\text{ °C}$, $U_{in} = 230\text{ V AC}$ and rated values, unless otherwise indicated



Type		CP-E 5/3.0	CP-E 12/2.5	CP-E 12/10.0
General data				
Power dissipation		typ. 5 W	typ. 5.6 W	typ. 24 W
Efficiency		typ. 75 %	typ. 84 %	typ. 84 %
Duty time		100 %		
Dimensions (W x H x D)		22.5 x 90 x 114 mm (0.89 x 3.54 x 4.49 in)	40.5 x 90 x 114 mm (1.59 x 3.54 x 4.49 in)	63.2 x 123.6 x 123.6 mm (2.49 x 4.87 x 4.87 in)
Weight		0.144 kg (0.317 lb)	0.287 kg (0.633 lb)	0.888 kg (1.958 lb)
Material of housing		Plastic		Metal
Mounting		DIN rail (IEC/EN 60715), snap-on mounting without any tool		
Mounting position		horizontal		
Minimum distance to other units	horizontal / vertical	25 mm / 25 mm (0.98 in / 0.98 in)		
Degree of protection	housing / terminals	IP20 / IP20		
Protection class		I		
Electrical connection - input circuit / output circuit				
Wire size	fine-strand with wire end ferrule	0.2-2.5 mm ² (24-14 AWG)		0.2-4 mm ² (24-11 AWG)
	fine-strand without wire end ferrule			0.2-6 mm ² (24-10 AWG)
	rigid			
Stripping length		6 mm (0.24 in)	8 mm (0.31 in)	
Tightening torque	input / output	0.6 Nm (5 lb.in)		1.0 Nm (9 lb.in) / 0.62 Nm (5.5 lb.in)
Environmental data				
Ambient temperature range	operation	-20...+70 °C	-40...+70 °C	-35...+70 °C
	rated load	-20...+60 °C	-40...+60 °C	-35...+60 °C
	storage	-20...+85 °C	-40...+85 °C	-40...+85 °C
Damp heat (cyclic) (IEC/EN 60068-2-30)		95 RH, % without condensation		
Vibration (sinusoidal) (IEC/EN 60068-2-6)		10-500 Hz, 2 G, along X, Y, Z each axis, 60 min. for each axis		
Shock (half-sine) (IEC/EN 60068-2-27)		15 G, 11 ms, 3 axes, 6 faces, 3 times for each face		
Isolation data				
Rated insulation voltage U_i	input circuit / output circuit	3 kV AC		
	input / PE	1.5 kV AC		
	output / PE	0.5 kV AC; 0.71 kV DC		
Pollution degree		2		
Overvoltage category (UL/IEC/EN 60950-1)		II		
Standards				
Product standard		EN 61204-3		
Low Voltage Directive		2006/95/EC		
EMC directive		2004/108/EC		
RoHS directive		2002/95/EC		
Electrical safety		EN 60950-1, UL 60950-1, UL 508	EN 60950-1, UL 60950-1, UL 508, EN 61558-1, EN 61558-2-17; EN 60204-1	
Protective low voltage		SELV (EN 60950)		
Electromagnetic compatibility				
Interference immunity to		IEC/EN 61000-6-2		
electrostatic discharge	IEC/EN 61000-4-2	Level 4 (air discharge 15 kV / contact discharge 8 kV)		
radiated, radio-frequency, electromagnetic field	IEC/EN 61000-4-3	Level 3 (10 V/m)		
electrical fast transient/burst	IEC/EN 61000-4-4	Level 4 (4 kV / 2,5 kHz)	Level 4 (4 kV / 5 kHz)	
surge	IEC/EN 61000-4-5	L-L Level 3 (2 kV) / L-PE Level 4 (4 kV)		
conducted disturbances, induced by radio-frequency fields	IEC/EN 61000-4-6	Level 3 (10 V)		
power frequency magnetic fields	IEC/EN 61000-4-8	Level 4 (30 A/m)		
voltage dips, short interruptions and voltage variations	IEC/EN 61000-4-11	dip: >95 % 10 ms / >30 % 500 ms interruptions: >95 % 5000 ms		
Interference emission		IEC/EN 61000-6-3		
high-frequency radiated	IEC/CISPR 22, EN 55022	Class B		
high-frequency conducted	IEC/CISPR 22, EN 55022	Class B		
limits for harmonic current emissions	IEC/EN 61000-3-2	Class D	Class A	Class D

„Approvals and marks“ on page 3/4.

CP-E range

Technical data

Data at $T_a = 25\text{ °C}$, $U_{in} = 230\text{ V AC}$ and rated values, unless otherwise indicated

Type		CP-E 24/0.75	CP-E 24/1.25	CP-E 24/2.5
Input circuit			L, N	
Rated input voltage U_n		100-240 V AC		
Input voltage range		90-264 V AC / 120-375 V DC	85-264 V AC / 90-375 V DC	
Frequency range AC		47-63 Hz		
Typical input current	at 115 V AC	335 mA	560 mA	1060 mA
	at 230 V AC	210 mA	330 mA	590 mA
Typical power consumption		22.8 W	36.7 W	69.2 W
Inrush current limiting	at 115 V AC	10 A (max. 3 ms)	20 A (max. 3 ms)	20 A (max. 3 ms)
	at 230 V AC	18 A (max. 3 ms)	40 A (max. 3 ms)	40 A (max. 3 ms)
Discharge current	input / output	0.25 mA		
	input / PE	3.5 mA		
Power failure buffering time	at 115 V AC	min. 20 ms	min. 20 ms	
	at 230 V AC	min. 75 ms	min. 30 ms	
Internal input fuse		2 A slow-acting / 250 V AC		
Power factor correction (PFC)		no		
Indication of operational states				
Output voltage	green LED	OK:  : output voltage OK	OUTPUT OK:  : output voltage OK	
	red LED	LOW:  : output voltage too low	-	-
Output circuit		L+,L-	L+, L+, L-, L-	
Rated output voltage		24 V DC		
Tolerance of the output voltage		0 ... +1 %		
Adjustment range of the output voltage		21.6-28.8 V DC	24-28 V DC	
Rated output power		18 W	30 W	60 W
Rated output current I_o	$T_a \leq 60\text{ °C}$	0.75 A	1.25 A	2.5 A
Derating of the output current	$60\text{ °C} < T_a \leq 70\text{ °C}$	2.5 %/°C		
Signalling output for output voltage OK	DC OK	-	transistor	
Maximum deviation with	load change statical	±2 %	±0.5 %	
	change of output voltage within the input voltage range	±1 %	±0.5 %	
Control time		< 2 ms		
Starting time after applying the supply voltage	at I_o	max. 1 s		
	with 3500 µF	-	max. 2 s	-
	with 7000 µF	max. 1.5 s	-	max. 1.5 s
Rise time	at rated load	max. 150 ms		
	with 3500 µF	-	max. 500 ms	-
	with 7000 µF	max. 500 ms	-	max. 500 ms
Fall time		max. 150 ms		
Residual ripple and switching peaks	BW = 20 MHz	50 mV		
Parallel connection		yes, to enable redundancy		
Series connection		yes, to increase voltage		
Resistance to reverse feed		1 s - max. 35 V DC		
Output circuit - No-load, overload and short-circuit behaviour				
Characteristic curve of output		Hiccup-mode	U/I characteristic curve	
Short-circuit protection		continuous short-circuit proof		
Short-circuit behaviour		Hiccup-mode	continuation with output power limiting	
Overload protection		output power limiting		
No-load protection		continuous no-load stability		
Starting of capacitive loads		7000 µF	3500 µF	7000 µF

CP-E range

Technical data

Data at $T_a = 25\text{ °C}$, $U_{in} = 230\text{ V AC}$ and rated values, unless otherwise indicated



Type		CP-E 24/0.75	CP-E 24/1.25	CP-E 24/2.5
General data				
Power dissipation		typ. 4.45 W	typ. 5.5 W	typ. 8.8 W
Efficiency		typ. 77 %	typ. 86 %	typ. 89 %
Duty time		100 %		
Dimensions (W x H x D)		22.5 x 90 x 114 mm (0.89 x 3.54 x 4.49 in)	40.5 x 90 x 114 mm (1.59 x 3.54 x 4.49 in)	
Weight		0.143 kg (0.315 lb)	0.270 kg (0.60 lb)	0.331 kg (0.73 lb)
Material of housing		Plastic		
Mounting		DIN rail (IEC/EN 60715), snap-on mounting without any tool		
Mounting position		horizontal		
Minimum distance to other units	horizontal / vertical	25 mm / 25 mm (0.98 in / 0.98 in)		
Degree of protection	housing / terminals	IP20 / IP20		
Protection class		I		
Electrical connection - input circuit / output circuit				
Wire size	fine-strand with wire end ferrule fine-strand without wire end ferrule rigid	0.2-2.5 mm ² (24-14 AWG)		
Stripping length		6 mm (0.24 in)		
Tightening torque	input / output	0.6 Nm (5 lb.in)		
Environmental data				
Ambient temperature range	operation rated load storage	-20...+70 °C -20...+60 °C -20...+85 °C	-40...+70 °C -40...+60 °C -40...+85 °C	
Damp heat (cyclic) (IEC/EN 60068-2-30)		95 % RH, without condensation		
Vibration (sinusoidal) (IEC/EN 60068-2-6)		10-500 Hz, 2 G, along X, Y, Z each axis, 60 min. for each axis		
Shock (half-sine) (IEC/EN 60068-2-27)		15 G, 11 ms, 3 axes, 6 faces, 3 times for each face		
Isolation data				
Rated insulation voltage U_i	input circuit / output circuit input / PE output / PE	3 kV AC 1.5 kV AC 0.5 kV AC; 0.71 kV DC		
Pollution degree		2		
Overvoltage category (UL/IEC/EN 60950-1)		II		
Standards				
Product standard		EN 61204-3		
Low Voltage Directive		2006/95/EC		
EMC directive		2004/108/EC		
RoHS directive		2002/95/EC		
Electrical safety		EN 50178, EN 60950-1, UL 60950-1, UL 508	EN 60950-1, UL 60950-1, UL 508, EN 61558-1, EN 61558-2-17; EN 60204-1	
Protective low voltage		SELV (EN 60950)		
Electromagnetic compatibility				
Interference immunity to		IEC/EN 61000-6-2		
electrostatic discharge	IEC/EN 61000-4-2	Level 4 (air discharge 15 kV / contact discharge 8 kV)		
radiated, radio-frequency, electromagnetic field	IEC/EN 61000-4-3	Level 3 (10 V/m)		
electrical fast transient/burst	IEC/EN 61000-4-4	Level 4 (4 kV / 2.5 kHz)	Level 4 (4 kV / 5 kHz)	
surge	IEC/EN 61000-4-5	L-L Level 3 (2 kV) / L-PE Level 4 (4 kV)		
conducted disturbances, induced by radio-frequency fields	IEC/EN 61000-4-6	Level 3 (10 V)		
power frequency magnetic fields	IEC/EN 61000-4-8	Level 4 (30 A/m)		
voltage dips, short interruptions and voltage variations	IEC/EN 61000-4-11	dip: >95 % 10 ms / >30 % 500 ms, interruptions: >95 % 5000 ms		
Interference emission		IEC/EN 61000-6-3		
high-frequency radiated	IEC/CISPR 22, EN 55022	Class B		
high-frequency conducted	IEC/CISPR 22, EN 55022	Class B		
limits for harmonic current emissions	IEC/EN 61000-3-2	Class D	Class A	

„Approvals and marks“ on page 3/4.

CP-E range

Technical data

Data at $T_a = 25\text{ °C}$, $U_{in} = 230\text{ V AC}$ and rated values, unless otherwise indicated

Type		CP-E 24/5.0	CP-E 24/10.0	CP-E 24/20.0
Input circuit		L, N		
Rated input voltage U_n		115 / 230 V AC auto select		115-230 V AC
Input voltage range		90-132 V AC, 180-264 V AC / 210-375 V DC	90-132 V AC, 180-264 V AC / 210-375 V DC	90-264 V AC, 120-375 V DC
Frequency range AC		47-63 Hz		
Typical input current	at 115 V AC	2.2 A	4.0 A	4.9 A
	at 230 V AC	0.83 A	1.55 A	2.5 A
Typical power consumption		140 W	270 W	539 W
Inrush current limiting	at 115 V AC	24 A (max. 5 ms)	30 A (max. 5 ms)	25 A (max. 5 ms)
	at 230 V AC	48 A (max. 5 ms)	60 A (max. 5 ms)	50 A (max. 5 ms)
Discharge current	input / output	0.25 mA		
	input / PE	3.5 mA		
Power failure buffering time	at 115 V AC	min. 25 ms		
	at 230 V AC	min. 30 ms		
Internal input fuse		3.15 A slow-acting / 250 V AC	6.3 A slow-acting / 250 V AC	10 A slow-acting / 250 V AC
Power factor correction (PFC)		yes, passive, 0.7		yes, active 115 V AC: 0.99 230 V AC: 0.97
Indication of operational states				
Output voltage	green LED	OUTPUT OK:  : output voltage OK		
	red LED	OUTPUT LOW:  : output voltage too low		
Output circuit		L+, L+, L-, L-		
Rated output voltage		24 V DC		
Tolerance of the output voltage		0...+1 %		
Adjustment range of the output voltage		22.5-28.5 V DC		
Rated output power		120 W	240 W	480 W
Rated output current I_L	$T_a \leq 60\text{ °C}$	5 A	10 A	-
	$T_a \leq 55\text{ °C}$	-	-	20 A
Derating of the output current	$60\text{ °C} < T_a \leq 70\text{ °C}$	2.5 %/°C		-
	$55\text{ °C} < T_a \leq 70\text{ °C}$	-	-	2.5 %/°C
Signalling contact for output voltage OK	13-14	solid-state (max. 60 V DC, 0.3 A)		
Minimum fuse rating to achieve short-circuit protection	13-14	$\geq 60\text{ V DC}$, $\leq 0.3\text{ A}$ fast-acting		
Maximum deviation with	load change statical	$\pm 1\%$ (single mode), $\pm 5\%$ (parallel mode)		
	change of output voltage within the input voltage range	$\pm 0.5\%$		
Control time		< 2 ms		
Starting time after applying the supply voltage	at I_L	max. 1 s		
	with 3500 μF	max. 1.5 s	-	-
	with 7000 μF	-	max. 1.5 s	-
Rise time	at rated load	max. 150 ms		
	with 3500 μF	max. 500 ms	-	-
	with 7000 μF	-	max. 500 ms	-
Fall time		max. 150 ms		
Residual ripple and switching peaks	BW = 20 MHz	50 mV	100 mV	
Parallel connection		configurable, to increase power, up to 3 devices, min. 0.1 I_L - max. 0.9 I_L		
Series connection		yes, to increase voltage, max. 2 devices		
Resistance to reverse feed		max. 35 V DC		
Output circuit - No-load, overload and short-circuit behaviour				
Characteristic curve of output		U/I characteristic curve		
Short-circuit protection		continuous short-circuit proof		
Short-circuit behaviour		continuation with output power limiting		
Overload protection		output power limiting		
No-load protection		continuous no-load stability		
Starting of capacitive loads		3500 μF	7000 μF	

CP-E range

Technical data

Data at $T_a = 25\text{ °C}$, $U_{in} = 230\text{ V AC}$ and rated values, unless otherwise indicated

Type		CP-E 24/5.0	CP-E 24/10.0	CP-E 24/20.0
General data				
Power dissipation		typ. 20 W	typ. 35 W	typ. 63 W
Efficiency		typ. 86 %	typ. 89 %	typ. 89 %
Duty time		100 %		
Dimensions (W x H x D)		63.2 x 123.6 x 123.6 mm (2.49 x 4.87 x 4.87 in)	83 x 123.6 x 123.6 mm (3.27 x 4.87 x 4.87 in)	175 x 123.6 x 123.6 mm (6.89 x 4.87 x 4.87 in)
Weight		0.882 kg (1.945 lb)	1.334 kg (2.941 lb)	1.850 kg (4.079 lb)
Material of housing		Metal		
Mounting		DIN rail (IEC/EN 60715), snap-on mounting without any tool		
Mounting position		horizontal		
Minimum distance to other units	horizontal / vertical	25 mm / 25 mm (0.98 in / 0.98 in)		
Degree of protection	housing / terminals	IP20 / IP20		
Protection class		I		
Electrical connection - input circuit / output circuit				
Wire size	fine-strand with wire end ferrule	0.2-4 mm ² (24-11 AWG)		
	fine-strand without wire end ferrule	0.2-6 mm ² (24-10 AWG)		
	rigid			
Stripping length		8 mm (0.31 in)		
Tightening torque	input / output	1.0 Nm (9 lb.in) / 0.62 Nm (5.5 lb.in)		
Environmental data				
Ambient temperature range	operation	-35...+70 °C	-40...+70 °C	
	rated load	-35...+60 °C	-40...+60 °C	-40...+55 °C
	storage	-40...+85 °C	-40...+85 °C	
Damp heat (cyclic) (IEC/EN 60068-2-30)		95 %RH, without condensation		
Vibration (sinusoidal) (IEC/EN 60068-2-6)		10-500 Hz, 2 G, along X, Y, Z each axis, 60 min. for each axis		
Shock (half-sine) (IEC/EN 60068-2-27)		15 G, 11 ms, 3 axes, 6 faces, 3 times for each face		
Isolation data				
Rated insulation voltage U_i	input circuit / output circuit	3 kV AC		
	input / PE	1.5 kV AC		
	output / PE	0.5 kV AC; 0.71 kV DC		
	signalling contact / PE	0.5 kV DC		
Pollution degree		2		
Overvoltage category (UL/IEC/EN 60950-1)		II		
Standards				
Product standard		EN 61204-3		
Low Voltage Directive		2006/95/EC		
EMC directive		2004/108/EC		
RoHS directive		2002/95/EC		
Electrical safety		EN 60950-1, UL 60950-1, UL 508, EN 61558-1, EN 61558-2-17; EN 60204-1		
Protective low voltage		SELV (EN 60950)		
Electromagnetic compatibility				
Interference immunity to		IEC/EN 61000-6-2		
electrostatic discharge	IEC/EN 61000-4-2	Level 4 (air discharge 15 kV / contact discharge 8 kV)		
radiated, radio-frequency, electromagnetic field	IEC/EN 61000-4-3	Level 3 (10 V/m)		
electrical fast transient/burst	IEC/EN 61000-4-4	Level 4 (4 kV / 5 kHz)	Level 4 (4 kV / 2.5 kHz)	
surge	IEC/EN 61000-4-5	L-L Level 3 (2 kV) / L-PE Level 4 (4 kV)		
conducted disturbances, induced by radio-frequency fields	IEC/EN 61000-4-6	Level 3 (10 V)		
power frequency magnetic fields	IEC/EN 61000-4-8	Level 4 (30 A/m)		
voltage dips, short interruptions and voltage variations	IEC/EN 61000-4-11	dip: >95 % 10 ms / >30 % 500 ms interruptions: >95 % 5000 ms		
Interference emission		IEC/EN 61000-6-3		
high-frequency radiated	IEC/CISPR 22, EN 55022	Class B		
high-frequency conducted	IEC/CISPR 22, EN 55022	Class B		
limits for harmonic current emissions		Class D		

„Approvals and marks“ on page 3/4.

CP-E range

Technical data

Data at $T_a = 25\text{ °C}$, $U_{in} = 230\text{ V AC}$ and rated values, unless otherwise indicated

Type	CP-E 48/0.62	CP-E 48/1.25	CP-E 48/5.0	CP-E 48/10.0
Input circuit				
L, N				
Rated input voltage U_{in}	100-240 V AC		115 / 230 V AC auto select	115-230 V AC
Input voltage range	85-264 V AC / 90-375 V DC		90-132 V AC, 180-264 V AC / 210-375 V DC	90-264 V AC, 120-375 V DC
Frequency range AC	47-63 Hz			
Typical input current	at 115 V AC 560 mA at 230 V AC 330 mA	1060 mA 590 mA	4.0 A 1.55 A	4.9 A 2.5 A
Typical power consumption	35.7 W			
Inrush current limiting	at 115 V AC 20 A (max. 3 ms) at 230 V AC 40 A (max. 3 ms)	20 A (max. 3 ms) 40 A (max. 3 ms)	30 A (max. 5 ms) 60 A (max. 5 ms)	25 A (max. 5 ms) 50 A (max. 5 ms)
Discharge current	input / output input / PE	0.25 mA 3.5 mA		
Power failure buffering time	at 115 V AC min. 20 ms at 230 V AC min. 30 ms		min. 25 ms	min. 25 ms
Internal input fuse	2 A slow-acting / 250 V AC		6.3 A slow-acting / 250 V AC	10 A slow-acting / 250 V AC
Power factor correction (PFC)	no		yes, passive, 0.7	yes, active 115 V AC: 0.99 230 V AC: 0.97
Indication of operational states				
Output voltage	green LED red LED	OUTPUT OK: <input type="checkbox"/> <input type="checkbox"/> L: output voltage OK OUTPUT LOW: <input type="checkbox"/> <input type="checkbox"/> L: output voltage too low		
L+, L+, L-, L-				
Rated output voltage	48 V DC			
Tolerance of the output voltage	0...+1 %			
Adjustment range of the output voltage	48-55 V DC		47-56 V DC	
Rated output power	30 W	60 W	240 W	480 W
Rated output current I_L	$T_a \leq 60\text{ °C}$ 0.625 A $T_a \leq 55\text{ °C}$ -	1.25 A -	5 A -	- 10 A
Derating of the output current	$60\text{ °C} < T_a \leq 70\text{ °C}$ 2.5 %/°C $55\text{ °C} < T_a \leq 70\text{ °C}$ -	- -	- -	- 2.5 %/°C
Signalling output for output voltage OK	DC OK			
Maximum deviation with load change statical	$\pm 0.5\%$		$\pm 1\%$ (single mode) $\pm 5\%$ (parallel mode)	
change of output voltage within the input voltage range	$\pm 0.5\%$		$\pm 0.5\%$	
Control time	< 2 ms			
Starting time after applying the supply voltage	at I_L max. 1 s with 3500 μF max. 2 s with 7000 μF -	- -	- max. 1.5 s	- max. 1.5 s
Rise time	at rated load max. 150 ms with 3500 μF max. 500 ms with 7000 μF -	- -	- max. 500 ms	- max. 500 ms
Fall time	max. 150 ms			
Residual ripple and switching peaks	BW = 20 MHz 50 mV		100 mV	
Parallel connection	yes, to enable redundancy		configurable, to increase power, up to 3 devices, min. 0.1 I_L - max. 0.9 I_L	
Series connection	yes, to increase voltage		yes, to increase voltage, max. 2 devices	
Resistance to reverse feed	1 s - max. 63 V DC			
Output circuit - No-load, overload and short-circuit behaviour				
Characteristic curve of output	U/I characteristic curve			
Short-circuit protection	continuous short-circuit proof			
Short-circuit behaviour	continuation with output power limiting			
Overload protection	output power limiting			
No-load protection	continuous no-load stability			
Starting of capacitive loads	3500 μF	7000 μF	unlimited	7000 μF

CP-E range

Technical data

Data at $T_a = 25\text{ °C}$, $U_{in} = 230\text{ V AC}$ and rated values, unless otherwise indicated

Type	CP-E 48/0.62	CP-E 48/1.25	CP-E 48/5.0	CP-E 48/10.0
General data				
Power dissipation	typ. 4.9 W	typ. 7.8 W	typ. 32 W	typ. 60 W
Efficiency	typ. 86 %	typ. 89 %	typ. 90 %	
Duty time	100 %			
Dimensions (W x H x D)	40.5 x 90 x 114 mm (1.59 x 3.54 x 4.49 in)		83 x 123.6 x 123.6 mm (3.27 x 4.87 x 4.87 in)	175 x 123.6 x 123.6 mm (6.89 x 4.87 x 4.87 in)
Weight	0.264 kg (0.582 lb)	0.316 kg (0.697 lb)	1.322 kg (2.915 lb)	1.839 kg (4.054 lb)
Material of housing	Plastic		Metal	
Mounting	DIN rail (IEC/EN 60715), snap-on mounting without any tool			
Mounting position	horizontal			
Minimum distance to other units	horizontal / vertical		25 mm / 25 mm (0.98 in / 0.98 in)	
Degree of protection	housing / terminals		IP20 / IP20	
Protection class	I			
Electrical connection - input circuit / output circuit				
Wire size	fine-strand with wire end ferrule		0.2-4 mm ² (24-11 AWG)	
	fine-strand without wire end ferrule		0.2-2.5 mm ² (24-14 AWG)	
	rigid		0.2-6 mm ² (24-10 AWG)	
Stripping length	6 mm (0.24 in)		8 mm (0.31 in)	
Tightening torque	input / output		0.6 Nm (5 lb.in) / 1.0 Nm (9 lb.in) / 0.62 Nm (5.5 lb.in)	
Environmental data				
Ambient temperature range	operation		-40...+70 °C	
	rated load		-40...+60 °C	
	storage		-40...+85 °C	
Damp heat (cyclic) (IEC/EN 60068-2-30)	95 % RH, without condensation			
Vibration (sinusoidal) (IEC/EN 60068-2-6)	10-500 Hz, 2 G, along X, Y, Z each axis, 60 min. for each axis			
Shock (half-sine) (IEC/EN 60068-2-27)	15 G, 11 ms, 3 axes, 6 faces, 3 times for each face			
Insulation data				
Rated insulation voltage U_i	input circuit / output circuit		3 kV AC	
	input / PE		1.5 kV AC	
	output / PE		0.5 kV AC; 0.71 kV DC	
Pollution degree	2			
Overvoltage category (UL/IEC/EN 60950-1)	II			
Standards				
Product standard	EN 61204-3			
Low Voltage Directive	2006/95/EC			
EMC directive	2004/108/EC			
RoHS directive	2002/95/EC			
Electrical safety	EN 60950-1, UL 60950-1, UL 508, EN 61558-1, EN 61558-2-17; EN 60204-1			
Protective low voltage	SELV (EN 60950)			
Electromagnetic compatibility				
Interference immunity to	IEC/EN 61000-6-2			
electrostatic discharge	IEC/EN 61000-4-2	Level 4 (air discharge 15 kV / contact discharge 8 kV)		
radiated, radio-frequency, electromagnetic field	IEC/EN 61000-4-3	Level 3 (10 V/m)		
electrical fast transient/burst	IEC/EN 61000-4-4	Level 4 (4 kV / 5 kHz)	Level 4 (4 kV / 2.5 kHz)	
surge	IEC/EN 61000-4-5	L-L Level 3 (2 kV) / L-PE Level 4 (4 kV)		
conducted disturbances, induced by radio-frequency fields	IEC/EN 61000-4-6	Level 3 (10 V/m)		
power frequency magnetic fields	IEC/EN 61000-4-8	Level 4 (30 A/m)		
voltage dips, short interruptions and voltage variations	IEC/EN 61000-4-11	dip: >95 % 10 ms / >30 % 500 ms, interruptions: >95 % 5000 ms		
Interference emission	IEC/EN 61000-6-3			
high-frequency radiated	IEC/CISPR 22, EN 55022	Class B		
high-frequency conducted	IEC/CISPR 22, EN 55022	Class B		
limits for harmonic current emissions	Class A		Class D	

„Approvals and marks“ on page 3/4.

CP-E range

Technical diagrams, Wiring instructions

Output curve at $T_a = 25\text{ }^\circ\text{C}$

3

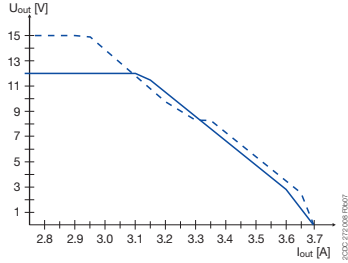

CP-E 12/2.5

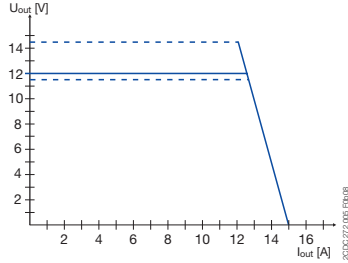

CP-E 12/10.0

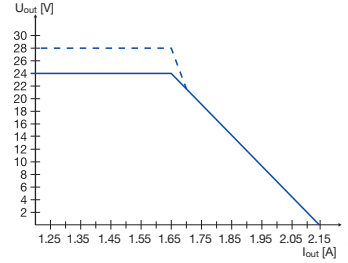

CP-E 24/1.25

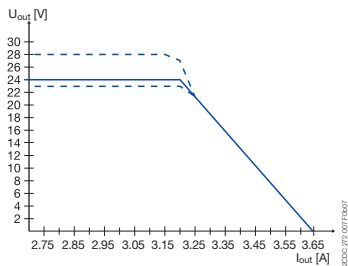

CP-E 24/2.5

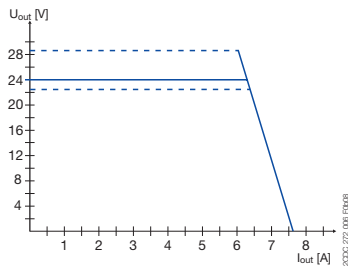

CP-E 24/5.0

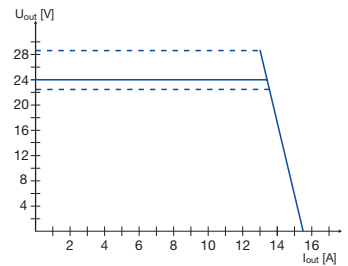

CP-E 24/10.0

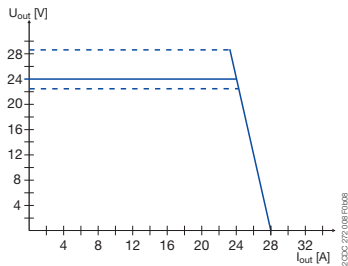

CP-E 24/20.0

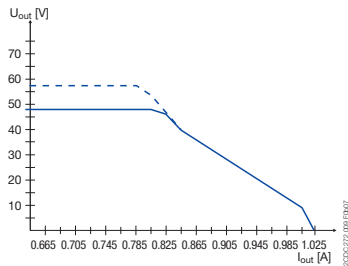

CP-E 48/0.62

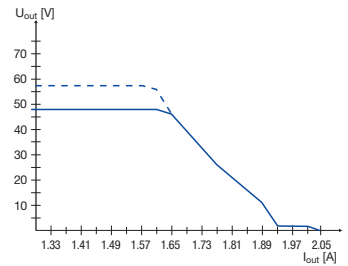

CP-E 48/1.25

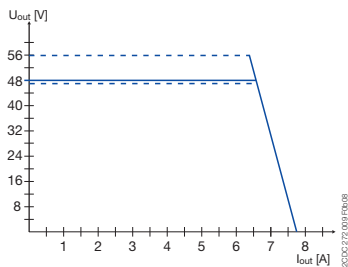

CP-E 48/5.0

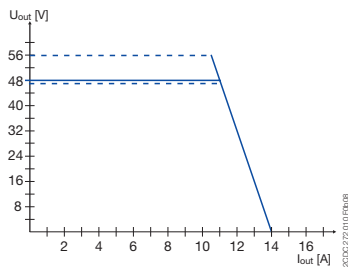

CP-E 48/10.0

Wiring instructions

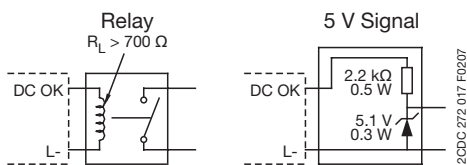

CP-E 24/1.25, CP-E 24/2.5

CP-E range

Technical diagrams, Dimensional drawings

Temperature behaviour at $T_a = 25\text{ }^\circ\text{C}$

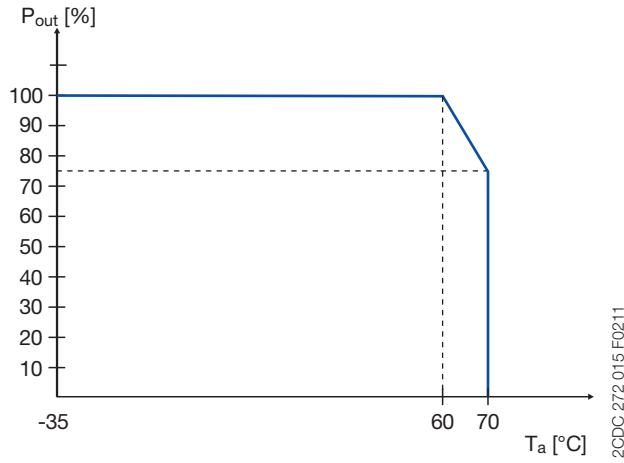

CP-E 12/10.0, CP-E 24/5.0

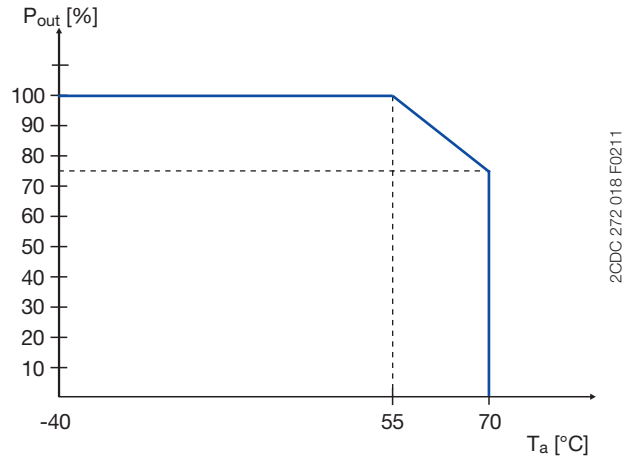

CP-E 24/20.0, CP-E 48/10.0

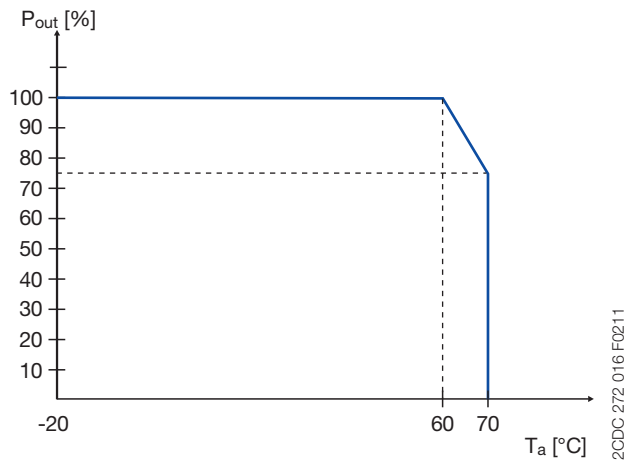

CP-E 5/3.0, CP-E 24/0.75

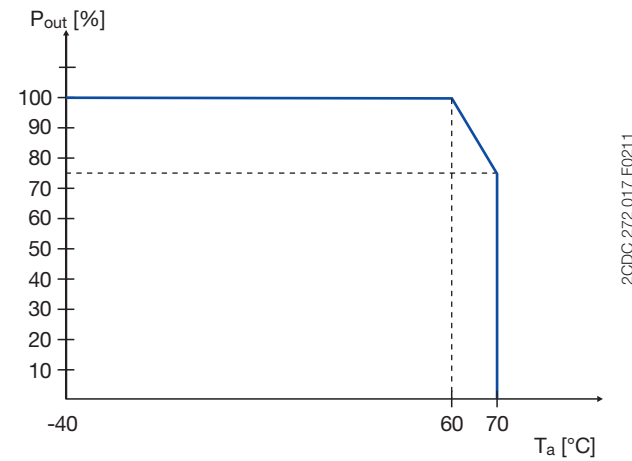

CP-E 12/2.5, CP-E 24/1.25, CP-E 48/0.62,
CP-E 24/2.5, CP-E 48/1.25, CP-E 24/10.0, CP-E 48/5.0

Dimensional drawings

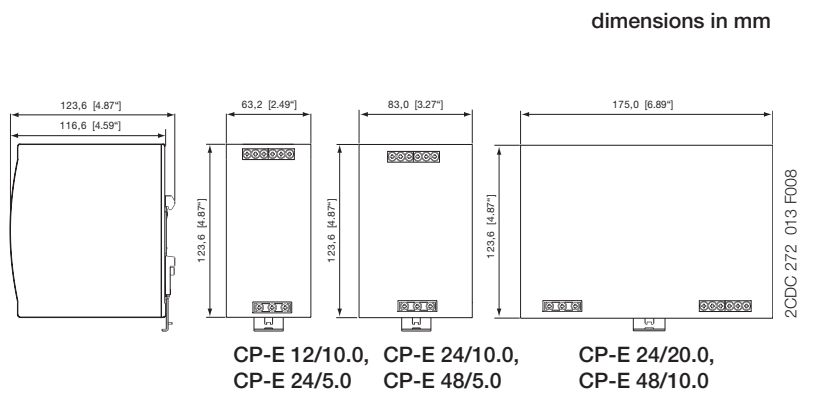
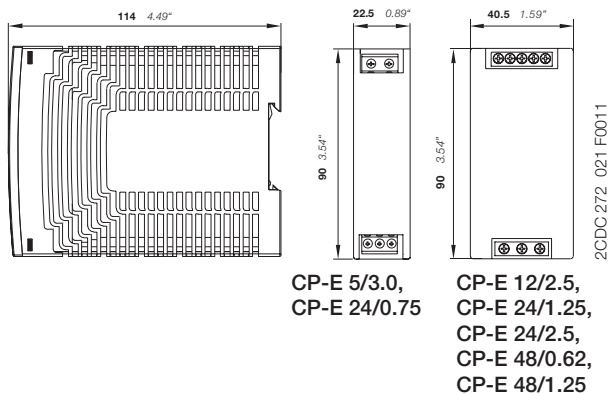

dimensions in mm

CP-T range Product group picture

3



CP-T range

Table of contents

CP-T range	
Product group picture	3/31
Table of contents	3/32
Benefits and advantages	3/33
Ordering details	3/34
Technical data	3/35
Technical diagrams, Dimensional drawings	3/39
Technical diagrams	3/40

CP-T range

Benefits and advantages

Characteristics

- Rated output voltages 24 V, 48 V DC
- Output voltage adjustable via front-face rotary potentiometer "OUTPUT Adjust"
- Rated output currents 5 A, 10 A, 20 A, 40 A
- Rated output powers 120 W, 240 W, 480 W, 960 W
- Three-phase or two-phase operation (see derating note)
- Supply range 3 x 400 – 500 V AC (3 x 340 – 575 V AC, 480 – 820 V DC)
- Typical efficiency of 93 %
- Low power dissipation and low heating
- Free convection cooling (no forced cooling with ventilators)
- Ambient temperature range during operation -40...+70 °C ¹⁾
- Open-circuit, overload and short-circuit stable
- Integrated input fuse
- Redundancy unit CP-A RU offering true redundancy, available as accessory
- LEDs for status indication
- Signalling contact "13-14" (solid state) for output voltage OK
- Approvals / marks (depending on device, partly pending):



¹⁾ 480 W variants: -30...+70°C

Benefits

Signalling output ①

The devices of the CP-T series offer a solid state output for function monitoring and remote diagnostics.

Wide input range

Wide range input optimized for world-wide applications:
The CP-T power supplies can be used in 340 - 575 V AC or 480 - 820 V DC supply systems.

Adjustable output voltage ②

The CP-T range feature a continuously adjustable output voltage. Thus, they can be optimally adapted to the application, e.g. compensating the voltage drop caused by a long line length.

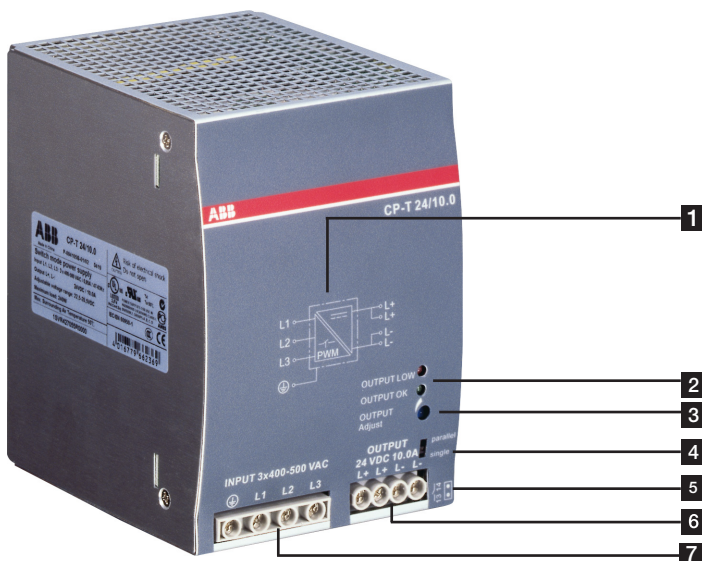
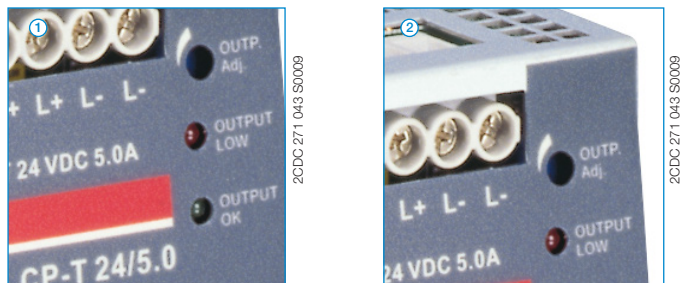

1 Circuit diagram

2 Indication of operational states

DC ON: green LED - green LED - output voltage OK

DC LOW: red LED - output voltage too low

3 single/parallel: sliding switch - adjustment of single or parallel operation

4 Configuration of single or parallel operation

5 Signalling contact

OUTPUT 13-14: terminals - signalling contact

A solid-state output indicates the error-free operation of the output voltage.

6 OUTPUT L+, L+, L-, L-: terminals - output

7 INPUT L1, L2, L3, PE: terminals - input

CP-T range

Ordering details



2CDC 271 048 S0009

CP-T 24/5.0



2CDC 271 048 S0009

CP-T 24/10.0, CP-T 48/5.0



2CDC 271 047 S0009

CP-T 24/20.0, CP-T 48/10.0

Description

The CP-T range of three-phase power supply units is the youngest member of ABB's power supply family. In terms of design and functionality, the new range perfectly supplements the existing products and extends the range appropriately. The devices can be supplied with a three-phase voltage as well as with two-phase mains. Here, ABB offers power supply units with 24 V DC and 48 V DC outputs with 5 A, 10 A, 20 A and 40 A and efficiency of up to 92 %. As in the case of all products, they are designed for an ambient temperature of up to 70 °C. All products can be supplied within an AC supply voltage range between 340 to 575 V AC and a DC supply voltage range between 480 to 820 V DC.

Ordering details

Input voltage range	Rated output voltage / current	Type	Order code	Price 1 pce	Weight (1 pce) kg (lb)
340-575 V AC / 480-820 V DC	24 V DC / 5 A	CP-T 24/5.0	1SVR427054R0000		0.80 (1.77)
340-575 V AC / 480-820 V DC	24 V DC / 10 A	CP-T 24/10.0	1SVR427055R0000		1.05 (2.31)
340-575 V AC / 480-820 V DC	24 V DC / 20 A	CP-T 24/20.0	1SVR427056R0000		1.75 (3.86)
340-575 V AC / 480-820 V DC	24 V DC / 40 A	CP-T 24/40.0	1SVR427057R0000		3.20 (7.05)
340-575 V AC / 480-820 V DC	48 V DC / 5 A	CP-E 48/5.0	1SVR427054R2000		1.05 (2.31)
340-575 V AC / 480-820 V DC	48 V DC / 10 A	CP-E 48/10.0	1SVR427055R2000		1.75 (3.86)
340-575 V AC / 480-820 V DC	48 V DC / 20 A	CP-E 48/20.0	1SVR427056R2000		3.40 (7.50)

CP-T range

Technical data

Data at $T_a = 25\text{ °C}$, $U_{in} = 3 \times 400\text{ V AC}$ and rated values, unless otherwise indicated

Type	CP-T 24/5.0	CP-T 24/10.0	CP-T 24/20.0	CP-T 24/40.0
Input circuit				
L1, L2, L3				
Rated input voltage U_n	3 x 400-500 V AC			
Input voltage range	340-575 V AC 480-820 V DC			
Frequency range AC	47-63 Hz			
Typical input current	0.36 A	0.65 A	1.1 A	1.72 A
Typical power consumption	135 W	270 W	538 W	1058 W
Inrush current limiting	10 A	20 A		30 A
Power failure buffering time	min. 20 ms			min. 15 ms
Internal input fuse	per phase 2 A / 600 V AC		T 3.15 A / 500 V AC	T 5 A / 500 V AC
Recommended backup fuse	3 pole miniature circuit breaker ABB Type S203			
Power factor correction (PFC)	Yes, passive			
Discharge current	towards PE input / output		< 0.25 mA	
Indication of operational states				
Output voltage	OUTPUT OK: green LED		output voltage OK	
	OUTPUT LOW: red LED		output voltage too low	
Output circuit				
L+, L+, L-, L-				
Rated output voltage	24 V DC			
Tolerance of the output voltage	0...+1 %			
Adjustment range of the output voltage	22.5-28.5 V DC			
Rated output power	120 W	240 W	480 W	960 W
Rated output current I_r	$T_a \leq 60\text{ °C}$ 5 A	10 A	20 A	40 A
Derating of the output current	$60\text{ °C} < T_a \leq 70\text{ °C}$	2.5 %/°C		3.5 %/°C
Signalling contact for output voltage OK	13-14	solid state (max. 60 V DC, 0.3 A)		
	Threshold	17.6-19.4 V		
	Insulation voltage	500 V DC		
Minimum fuse rating to achieve short-circuit protection	13-14	$\geq 60\text{ V DC}$, $\leq 0.3\text{ A}$ fast-acting		
Maximum deviation with	load change statical	$\pm 1\%$	$\pm 1\%$ (single mode)	$\pm 5\%$ (parallel mode)
	change of output voltage within the input voltage range	$\pm 0.5\%$		
Control time	at nominal load	< 2 ms		
Starting time after applying the supply voltage	at I_r	max. 1 s		
	with 3500 μF	max. 1.5 s		
Rise time	at nominal load	max. 150 ms		
	with 3500 μF	max. 500 ms		
Fall time		max. 150 ms		
Residual ripple and switching peaks	BW = 20 MHz	100 mV		80 mV
Parallel connection		not supported	configurable, to increase power, up to 2 devices, min. $0.1 I_r$ - max $0.9 I_r$	to increase power, up to 2 devices, min. $0.1 I_r$ - max. $0.9 I_r$, use active current balancing
Series connection		not supported	yes, to increase voltage, max. 2 devices	
Resistance to reverse feed		approx. 35 V		
Output circuit - No-load, overload and short-circuit behaviour				
Characteristic curve of output	combined U/I characteristic curve and hiccup mode		U/I- or Hiccup-mode adjustable	hiccup / fold back behavior
Short-circuit protection	continuous short-circuit proof			
Short-circuit behaviour	current limiting			
Overload protection	hiccup mode			
No-load protection	continuous no-load stability			
Overtemperature protection	yes, automatic recovery after temperature went down			
Starting of capacitive loads	3500 μF	7000 μF	7000 μF	7000 μF

CP-T range

Technical data

Data at $T_a = 25\text{ °C}$, $U_{in} = 3 \times 400\text{ V AC}$ and rated values, unless otherwise indicated

Type	CP-T 24/5.0	CP-T 24/10.0	CP-T 24/20.0	CP-T 24/40.0
General data				
Efficiency	typ. 89 %	typ. 90 %		typ. 92 %
Duty time	100%			
Dimensions (W x H x D)	74.3 x 124 x 118.8 mm (2.92 x 4.88 x 4.68 in)	89 x 124 x 118.8 mm (3.5 x 4.88 x 4.68 in)	150 x 124 x 118.8 mm (5.91 x 4.88 x 4.68 in)	275.8 x 124 x 118.8 mm (10.86 x 4.88 x 4.68 in)
Weight	0.78 kg (1.72 lb)	1.045 kg (2.30 lb)	1.657 kg (3.653 lb)	3.275 kg (7.220 lb)
Material of housing	Metal			
Mounting	DIN rail (IEC EN 60715), snap-on mounting without any tool			
Mounting position	horizontal			
Minimum distance to other units	horizontal / vertical 25 mm / 25 mm (0.98 in / 0.98 in)			
Degree of protection	housing / terminals IP20 / IP20			
Protection class	I			
Electrical connection - input circuit / output circuit / signalling circuit				
Wire size	fine-strand with wire end ferrule	0,2-4 mm ² (24-11 AWG)		
	fine-strand without wire end ferrule	0,2-6 mm ² (24-10 AWG)		
	rigid	0,2-6 mm ² (24-10 AWG)		
Stripping length	8 mm (0.31 in)			
Tightening torque	input / output	1 Nm (9 lb.in) / 0.6 Nm (5.5 lb.in)		1 Nm (9 lb.in) / 1.8 Nm (15.6 lb.in)
Environmental data				
Ambient temperature range	operation	-40...+70 °C	-30...+70 °C	-40...+70 °C
	rated load	-40...+60 °C	-30...+60 °C	-40...+60 °C
	storage	-40...+85 °C		
Damp heat (cyclic) (IEC/EN 60068-2-30)	95 % without condensation			
Vibration (sinusoidal) (IEC/EN 60068-2-6)	2 g, 10-500 Hz, 2G, each along X, Y, Z axes 60 min / cycle			
Shock (half-sine) (IEC/EN 60068-2-27)	15 g, 11 ms, 3 axes, 6 faces, 3 times for each face			
Isolation data				
Rated insulation voltage U_i	input circuit / output circuit	3 kV AC		
	input / PE	1.5 kV AC		
	output / PE	0.5 kV AC; 0.71 kV DC		
	signalling output / PE	0.5 kV DC		
Pollution degree	2			
Standards				
Product standard	EN 61204-3			
Low Voltage Directive	2006/95/EC			
EMC directive	2004/108/EC			
RoHS directive	2002/95/EC			
Electrical safety	EN 60950-1, UL 60950-1, UL 508, EN 61558-1, EN 61558-2-17; EN 60204-1			
Protective low voltage	SELV			
Electromagnetic compatibility				
Interference immunity to	IEC/EN 61000-6-2			
electrostatic discharge	IEC/EN 61000-4-2	Level 4 (air discharge 15 kV / contact discharge 8 kV)		
radiated, radio-frequency, electromagnetic field	IEC/EN 61000-4-3	Level 3 (10 V/m)		
electrical fast transient/burst	IEC/EN 61000-4-4	Level 4 (4 kV / 2.5 kHz)	Level 4 (4 kV / 5 kHz)	
surge	IEC/EN 61000-4-5	L-L Level 3 (2 kV) / L-PE Level 4 (4 kV)		
conducted disturbances, induced by radio-frequency fields	IEC/EN 61000-4-6	Level 3 (10 V)		
power frequency magnetic fields	IEC/EN 61000-4-8	Level 4 (30 A/m)		
voltage dips, short interruptions and voltage variations	IEC/EN 61000-4-11	dips: >95 % 0.5 ms / >30 % 0.5 ms, interruptions: >95 % 250 ms		
Interference emission	IEC/EN 61000-6-3			
high-frequency radiated	IEC/CISPR 22, EN 55022	Class B		
high-frequency conducted	IEC/CISPR 22, EN 55022	Class B		
limits for harmonic current emissions	IEC/EN 61000-3-2	Class A		

„Approvals and marks“ on page 3/4.

CP-T range

Technical data

Data at $T_a = 25\text{ °C}$, $U_{in} = 3 \times 400\text{ V AC}$ and rated values, unless otherwise indicated

Type	CP-T 48/5.0	CP-T 48/10.0	CP-T 48/20.0
Input circuit			
Rated input voltage U_n	3 x 400-500 V AC		
Input voltage range	340-575 V AC 480-820 V DC		
Frequency range AC	47-63 Hz		
Typical input current	0.65 A	1.1 A	1.72 A
Typical power consumption	264 W	535 W	1050 W
Inrush current limiting	20 A		30 A
Power failure buffering time	min. 20 ms		min. 15 ms
Internal input fuse	per phase 2 A / 600 V AC	T3.15 A / 500 V AC	T 5 A / 500 V AC
Power factor correction (PFC)	yes, passive		
Discharge current	towards PE < 3.5 mA		
	input / output < 0.25 mA		
Indication of operational states			
Output voltage	OUTPUT OK: green LED OUTPUT LOW: red LED	output voltage OK output voltage too low	
Output circuit			
Rated output voltage	48 V DC		
Tolerance of the output voltage	0...+1 %		
Adjustment range of the output voltage	47-56 V DC		
Rated output power	240 W	480 W	960 W
Rated output current I_r	$T_a \leq 60\text{ °C}$ 5 A	10 A	20 A
Derating of the output current	$60\text{ °C} < T_a \leq 70\text{ °C}$ 2.5 %/°C	3.5 %/°C	
Maximum deviation with	load change statical	$\pm 1\%$ (single mode) $\pm 5\%$ (parallel mode)	
	change of output voltage within the input voltage range	$\pm 0.5\%$	
Control time	at rated load	< 2 ms	
Starting time after applying the supply voltage	at I_r	max. 1 s	
	with 7000 μF	max. 1.5 s	
Rise time	at rated load	max. 150 ms	
	with 7000 μF	max. 500 ms	
Fall time	max. 150 ms		
Residual ripple and switching peaks	BW = 20 MHz	100 mV	80 mV
Parallel connection	configurable, to increase power, up to 2 devices, min. 0.1 I_r - max 0.9 I_r)		to increase power, up to 2 devices, min. 0.1 I_r - max. 0.9 I_r use active current balancing
Series connection	yes, to increase voltage, max. 2 devices		
Resistance to reverse feed	approx. 35 V	approx. 63 V	approx. 63 V
Output circuit - No-load, overload and short-circuit behaviour			
Characteristic curve of output	combined U/I and hiccup mode	U/I or hiccup mode, configurable	hiccup mode / fold back behavior
Short-circuit protection	continuous short-circuit proof		
Short-circuit behaviour	current limiting		
Overload protection	hiccup mode		
No-load protection	continuous no-load stability		
Over temperature protection	yes, automatic recovery after temperature went down		
Starting of capacitive loads	7000 μF		

CP-T range

Technical data

Data at $T_a = 25\text{ °C}$, $U_{in} = 3 \times 400\text{ V AC}$ and rated values, unless otherwise indicated

Type		CP-T 48/5.0	CP-T 48/10.0	CP-T 48/20.0
General data				
Efficiency		typ. 91 %		typ. 93 %
Duty time		100%		
Dimensions (W x H x D)		89 x 124 x 118.8 mm (3.5 x 4.88 x 4.68 in)	150 x 124 x 118.8 mm (5.91 x 4.88 x 4.68 in)	275.8 x 124 x 118.8 mm (10.86 x 4.88 x 4.68 in)
Weight		1.045 kg (2.30 lb)	1.657 kg (3.653 lb)	3.275 kg (7.22 lb)
Material of housing		Metal		
Mounting		DIN rail (IEC EN 60715), snap-on mounting without any tool		
Mounting position		horizontal		
Minimum distance to other units	horizontal / vertical	25 mm / 25 mm (0.98 in / 0.98 in)		
Degree of protection	housing / terminals	IP20 / IP20		
Protection class		I		
Electrical connection - input circuit / output circuit				
Wire size	fine-strand with wire end ferrule	0.2-4 mm ² (24-11 AWG)		0.2-4 mm ² (24-11 AWG) / 0.5-10 mm ² (20-8 AWG)
	fine-strand without wire end ferrule	0.2-6 mm ² (24-10 AWG)		
	rigid			
Stripping length		8 mm (0.31 in)		
Tightening torque	input / output	1 Nm (9 lb.in) / 0.6 Nm (5.5 lb.in)		1 Nm (9 lb.in) / 1.8 Nm (15.6 lb.in)
Environmental data				
Ambient temperature range	operation	-40...+70 °C	-30...+70 °C	-40...+70 °C
	rated load	-40...+60 °C	-30...+60 °C	-40...+60 °C
	storage	-40...+85 °C	-40...+85 °C	-40...+85 °C
Damp heat (cyclic) (IEC/EN 60068-2-30)		95 % without condensation		
Vibration (sinusoidal) (IEC/EN 60068-2-6)		10-500 Hz, 2G, each along X, Y, Z axes 6 min / cycle		
Shock (half-sine) (IEC/EN 60068-2-27)		15G, 11 ms, 3 axes, 6 Faces, 3 times for each face		
Isolation data				
Rated insulation voltage U_i	input circuit / output circuit	3 kV AC		
	input / PE	1.5 kV AC		
	output / PE	0.5 kV AC; 0.71 kV DC		
Pollution degree		2		
Standards				
Product standard		EN 61204-3		
Low Voltage Directive		2006/95/EC		
EMC directive		2004/108/EC		
RoHS directive		2002/95/EC		
Electrical safety		EN 60950-1, UL 60950-1, UL 508, EN 61558-1, EN 61558-2-17; EN 60204-1		
Protective low voltage		SELV		
Electromagnetic compatibility				
Interference immunity to		IEC/EN 61000-6-2		
electrostatic discharge	IEC/EN 61000-4-2	Level 4 (air discharge 15 kV / contact discharge 8 kV)		
radiated, radio-frequency, electromagnetic field	IEC/EN 61000-4-3	Level 3 (10 V/m)		
electrical fast transient/burst	IEC/EN 61000-4-4	Level 4 (4 kV / 5 kHz)		
surge	IEC/EN 61000-4-5	L-L Level 3 (2 kV) / L-PE Level 4 (4 kV)		
conducted disturbances, induced by radio-frequency fields	IEC/EN 61000-4-6	Level 3 (10 V)		
power frequency magnetic fields	IEC/EN 61000-4-8	Level 4 (30 A/m)		
voltage dips, short interruptions and voltage variations	IEC/EN 61000-4-11	dips: >95 % 0.5 ms / >30 % 0.5 ms interruptions: >95 % 250 ms IEC/EN 61000-6-3		
Interference emission		IEC/EN 61000-6-3		
high-frequency radiated	IEC/CISPR 22, EN 55022	Class B		
high-frequency conducted	IEC/CISPR 22, EN 55022	Class B		
limits for harmonic current emissions	IEC/EN 61000-3-2	Class A		

„Approvals and marks“ on page 3/4.

CP-T range

Technical diagrams, Dimensional drawings

Technical diagrams

Output curve at $T_j = 25\text{ }^\circ\text{C}$

dimensions in mm

3

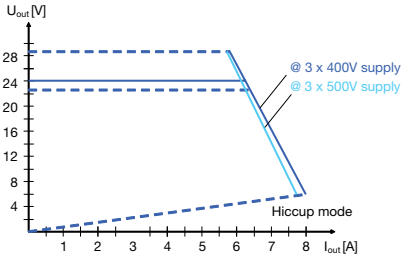

CP-T 24/5.0

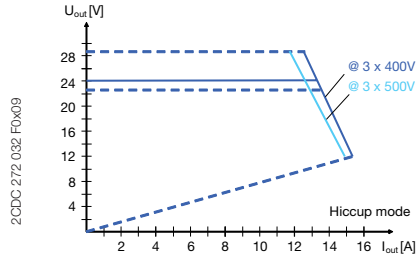

CP-T 24/10.0

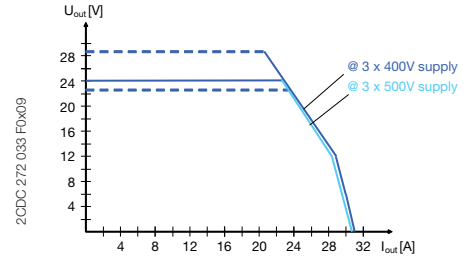

CP-T 24/20.0 U/I curve

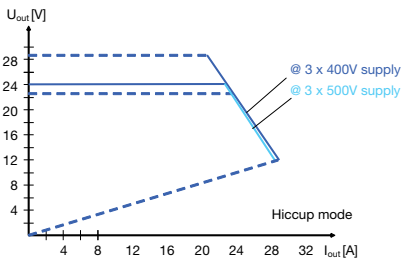

CP-T 24/20.0 Hiccup mode

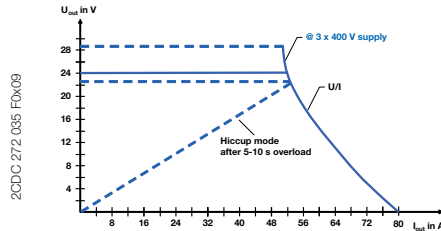

CP-T 24/40.0

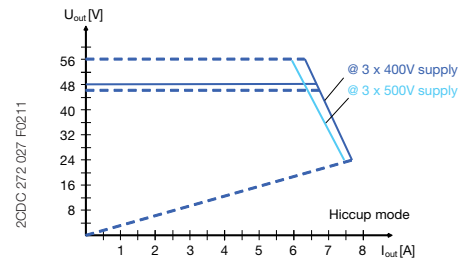

CP-T 48/5.0

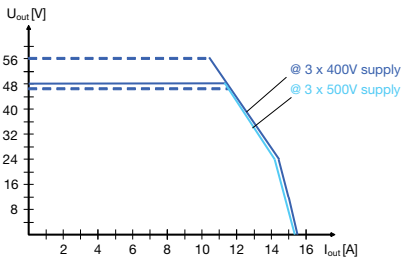

CP-T 48/10.0 U/I curve

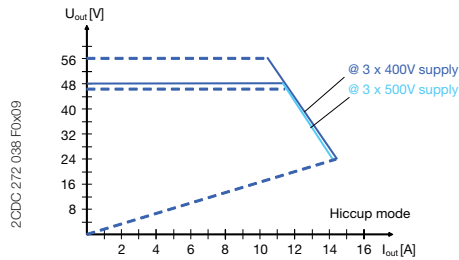

CP-T 48/10.0 Hiccup mode

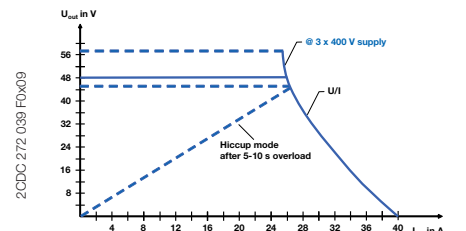

CP-T 48/20.0

Dimensional drawings

dimensions in mm

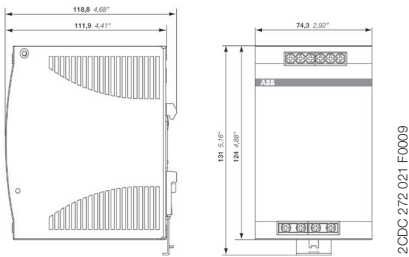

CP-T 24/5.0

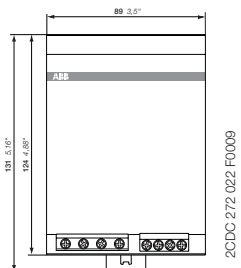

CP-T 24/10.0, CP-T 48/5.0

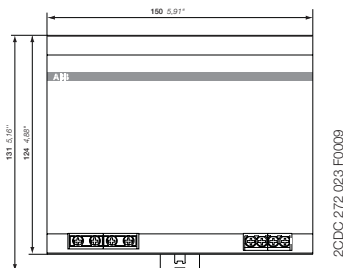

CP-T 24/20.0, CP-T 48/10.0

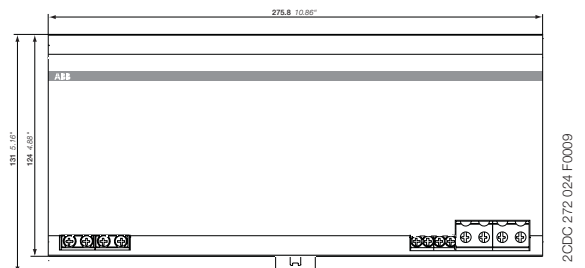

CP-T 24/40.0, CP-T 48/20.0

CP-T range

Technical diagrams

Temperature curve at rated load

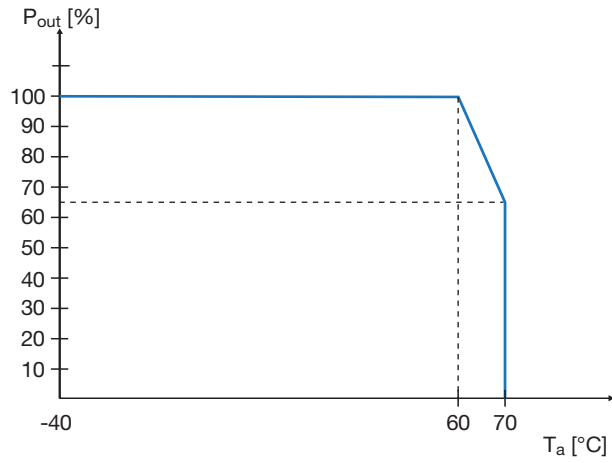

CP-T 24/40.0, CP-T 48/20.0

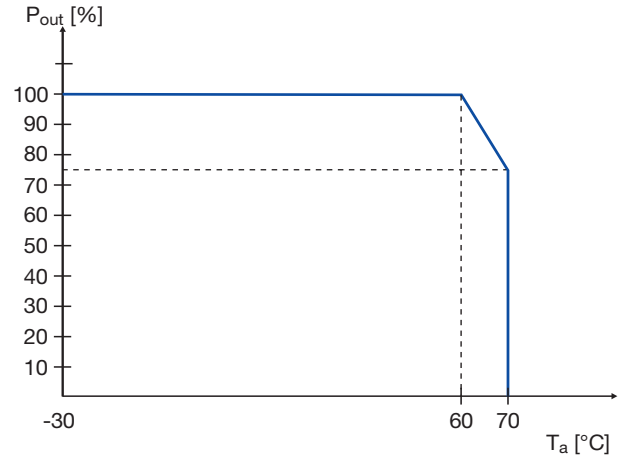

CP-T 24/20.0, CP-T 48/10.0

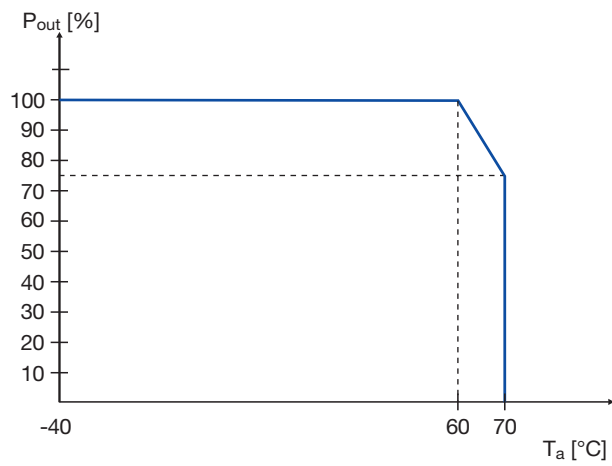

CP-T 24/5.0, CP-T 24/10.0, CP-T 48/5.0

CP-S and CP-C

Product group picture

3



CP-S and CP-C

Table of contents

CP-S and CP-C range	
Product group picture	3/41
Table of contents	3/42
Benefits and advantages	3/43
Operating control	3/44
Ordering details	3/45
Technical data	3/46
Technical diagrams, Dimensional drawings	3/50

CP-S and CP-C

Benefits and advantages

Characteristics

CP-S and CP-C range

- Output current 5 A, 10 A and 20 A
- Integrated power reserve of up to 50 %
- 5 A and 10 A devices with pluggable connecting terminals
- Approvals / marks (depending on device, partly pending)



CP-S range

- 10 A and 20 A device with front-face selector switch to adjust rated input voltage range: 110-120 V AC or 220-240 V AC
- Output voltage fixed at 24 V DC
- Parallel operation for redundancy

CP-C range

- Wide range input 110-240 V AC (85-264 V AC, 100-350 V DC)
- Output voltage adjustable within a range of 22-28 V DC
- Parallel operation for increased capacity and redundancy
- Power factor correction (PFC) acc. to EN 61000-3-2
- Function module pluggable onto the front side

Messaging module CP-C MM:

- LED for status indication
- Relay outputs "Input OK" and "Output OK"
- REMOTE ON/OFF function to switch on and off the power supply externally
- Output voltage monitoring is only possible in decoupled parallel operation

Benefits

Integrated power reserve ①

The new CP-S and CP-C range power supplies feature an integrated power reserve of up to 50 %. No oversized electricity supply is needed, especially under heavy load conditions.

Pluggable connecting terminals ②

Extended flexibility in operation due to pluggable connecting terminals (this feature is not offered on all devices).

Adjustable output voltage ③

The CP-C range types feature a continuously adjustable output voltage from 22 to 28 V. Thus, they can be optimally adapted to the application, e.g. compensating the voltage drop caused by long line length.

Pluggable function modules ④

The CP-C range power supplies can be equipped with pluggable modules to add additional functions (e.g. messaging module). Thus, the power supplies can be ideally adapted to the relevant application.

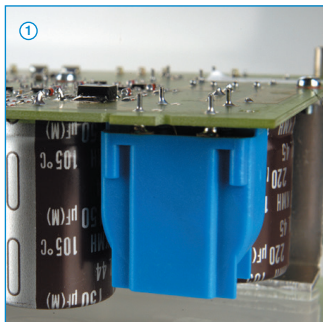

2CDC 27/3 056 F0004



2CDC 27/3 057 F0004



2CDC 27/3 046 F0004



2CDC 27/3 058 F0004

CP-S and CP-C Operating control



- 1** OUTPUT L+, L-: terminals - output
- 2** Indication of operational states
OUTPUT OK: green LED - output voltage OK
- 3** OUTPUT Adj.: rotary potentiometer - adjustment of output voltage
- 4** Circuit diagram
- 5** INPUT L, N, PE: terminals - input

3

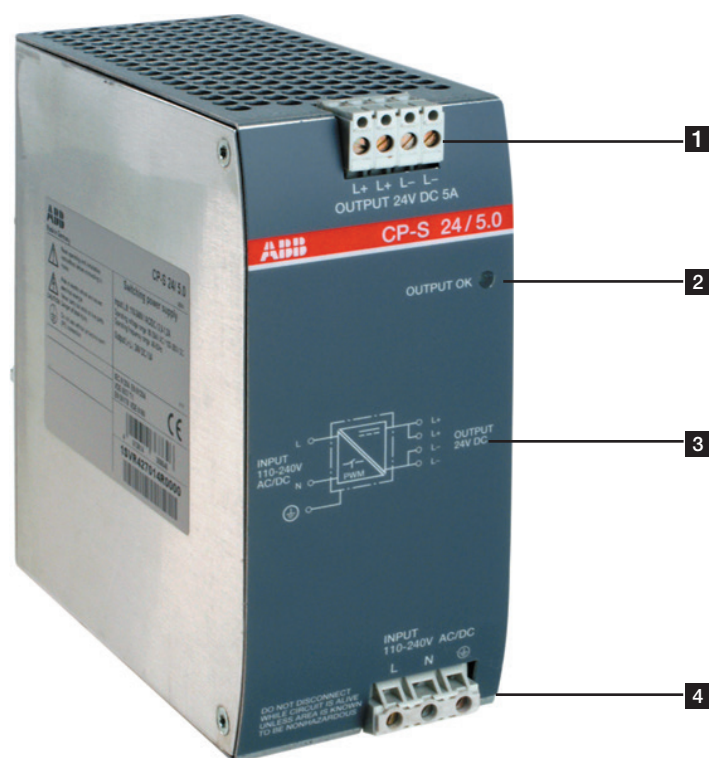

- 1** OUTPUT L+, L-: terminals - output
- 2** Indication of operational states
OUTPUT OK: green LED - output voltage OK
- 3** Circuit diagram
- 4** INPUT L, N, PE: terminals - input

CP-S and CP-C

Ordering details

3



2CDC 271 061 F0004

CP-S 24/5.0



2CDC 271 063 F0004

CP-S 24/20.0



2CDC 271 065 F0004

CP-C 24/10.0

Description

The power supply units in the CP-S and CP-C range are ABB's high-end solutions. Designed with an integrated 50 % power reserve and an efficiency of approximately 89 % these are the perfect products for all complex, highly reliable applications. All the devices cover the U-I output characteristic and are built with thermal protection which switches off in case of overheating. In particular, the devices of the CP-C range feature a much broader functionality, including active power factor correction and pluggable function modules.

These products are designed to trip MCB's in the 24VDC output circuit. Coordination tables are available.

Ordering details - CP-S

Input voltage range	Rated output voltage / current	Type	Order code	Price 1 pce	Weight (1 pce) kg (lb)
85-264 V AC / 110-350 V DC	24 V DC / 5 A	CP-S 24/5.0	1SVR427014R0000		0.96 (2.11)
85-132 V AC, 184-264 V AC / 220-350 V DC	24 V DC / 10 A	CP-S 24/10.0	1SVR427015R0100		1.07 (2.35)
85-132 V AC, 184-264 V AC / 220-350 V DC	24 V DC / 20 A	CP-S 24/20.0	1SVR427016R0100		2.83 (6.23)

Ordering details - CP-C

Input voltage range	Rated output voltage / current	Type	Order code	Price 1 pce	Weight (1 pce) kg (lb)
85-264 V AC / 110-350 V DC	24 V DC / 5 A	CP-C 24/5.0	1SVR427024R0000		0.96 (2.11)
85-264 V AC / 110-350 V DC	24 V DC / 10 A	CP-C 24/10.0	1SVR427025R0000		1.34 (2.95)
85-264 V AC / 110-350 V DC	24 V DC / 20 A	CP-C 24/20.0	1SVR427026R0000		3.15 (6.94)

Description	Type	Order code	Price 1 pce	Weight (1 pce) kg (lb)
Messaging module for CP-C range power supplies	CP-C MM	1SVR427081R0000		0.065 (0.14)

CP-S and CP-C

Technical data

Data at $T_a = 25\text{ °C}$, $U_{in} = 230\text{ V AC}$ and rated values, unless otherwise indicated

Type		CP-C 24/5.0 CP-S 24/5.0	CP-C 24/10.0 CP-S 24/10.0	CP-C 24/20.0 CP-S 24/20.0
Input circuit - supply circuit				
Rated input voltage U_{in}	CP-C	110-240 V AC	L, N	
	CP-S	switch position 115 switch position 230	110-240 V AC	110-120 V AC 220-240 V AC
Input voltage range	CP-C	85-264 V AC / 100-350 V DC ¹⁾	85-132 V AC	
	CP-S	switch position 115 switch position 230	85-264 V AC / 100-350 V DC ¹⁾	184-264 V AC / 220-350 V DC ¹⁾
Frequency range AC		47-63 Hz		
Typical input current	CP-S and CP-C at 110-240 V AC	2.2-1.2 A	2.6-1.2 A	5.5-2.5 A
	CP-S at 110-120 V AC	-	4.2-4.0 A	9.0-8.0 A
	CP-S at 220-240 V AC	-	2.4-2.2 A	4.5-4.0 A
Typ. power consumption		135 W	269 W	538 W
Inrush current limiting / I ² t (cold start)	CP-C	< 23 A / approx. 0.9 A ² s	< 33 A / approx. 0.2 A ² s	< 40 A / approx. 1.9 A ² s
	CP-S		< 40 A / approx. 1.8 A ² s	< 70 A / approx. 8 A ² s
Power failure buffering time		min. 100 ms	min. 40 ms	min. 40 ms
Transient overvoltage protection		varistors		
Internal input fuse (apparatus protection, not accessible)		4 A (slow-acting)	6.3 A (slow-acting)	12 A (fast-acting)
Power factor correction (PFC)	CP-C	yes, active		
	CP-S	no		
Indication of operational states				
Output voltage	OUTPUT OK: green LED	┌───┐: output voltage OK		
Output circuit				
Rated output voltage		24 V DC		
Tolerance of the output voltage	CP-C	±1 %		
	CP-S	-1...+5 %		
Adjustment range of the output voltage	CP-C	22-28 V DC, default setting 24 V ±0.5 %		
	CP-S	fixed		
Rated output power		120 W	240 W	480 W
Rated output current	$T_a \leq 60\text{ °C}$	5 A	10 A	20 A
Peak output current (power reserve)	$T_a \leq 40\text{ °C}$	typ. ≤ 7.25 A	typ. ≤ 12.25 A	typ. ≤ 22.5 A
Derating	$60\text{ °C} < T_a \leq 70\text{ °C}$	2.5 % per Kelvin temperature increase		
Deviation with	CP-C	load change statical 10-90 %	typ. < ±0.05 %	
	CP-S	load change statical 10-90 %	typ. < ±0.1 %	
		load change dynamical 10-90 %	typ. < ±3 %	
		change of the input voltage of ±10 %	typ. < ±0.05 %	
Control time		typ. < 1 ms		
Starting time after applying supply voltage	CP-C	< 200 ms	< 200 ms	typ. < 200 ms
	CP-S		< 250 ms	typ. < 300 ms
Rise time 10-90 %	CP-C	typ. < 30 ms	typ. < 4 ms	typ. < 12 ms
	CP-S		typ. < 5 ms	typ. < 15 ms
Residual ripple and switching peaks	BW = 20 MHz	typ. < 50 mV _{pp}		
Parallel connection		yes, up to 5 devices, to enable redundancy and to increase power, current not symmetrical (CP-S only redundancy)		
Series connection		yes, to increase voltage, for decoupling refer to the application manual		
Resistance to reverse feed		approx. 35 V DC		
Output circuit - No-load, overload and short-circuit behaviour				
Characteristic curve of output		see also U/I- and I/T-characteristic curves		
Current limiting at short circuit		U/I characteristic curve with power reserve		
Short-circuit protection		approx. 11 A	approx. 19 A	approx. 25 A
Overload protection		continuous short-circuit stability		
Starting of capacitive loads		thermal protection		
		unlimited		
General data				
Power dissipation		typ. < 15 W	typ. < 29 W	typ. < 58 W
Efficiency		typ. 89 %		
Discharge current for PE		< 3.5 mA		
MTBF	CP-C	500.000 h		
	CP-S	350.000 h		
Dimensions (W x H x D)		56.5 (60 ²⁾ x 130 x 135.5 mm (2.22 (2.36 ²⁾ x 5.12 x 5.35 in)	90 (93.5 ²⁾ x 130 x 135.5 mm (3.54 (3.68 ²⁾ x 5.12 x 5.35 in)	200 (203.5 ²⁾ x 130 x 135.5 mm (7.87 (8.01 ²⁾ x 5.12 x 5.35 in)
Weight	CP-C	approx. 0.96 kg (2.12 lb)	approx. 1.34 kg (2.95 lb)	approx. 3.15 kg (6.94 lb)
	CP-S		approx. 1.07 kg (2.36 lb)	approx. 2.83 kg (6.23 lb)
Minimum distance to other units	horizontal / vertical	10 mm / 80 mm (0.39 in / 3.15 in)		
Degree of protection	housing / terminals	IP20 / IP20		
Material of housing	housing shell / cover	aluminium / zinc-coated sheet steel		
Protection class (EN 61140)		I		
Mounting		DIN rail (IEC/EN 60715), snap-on mounting		
Mounting position		horizontal		

CP-S and CP-C

Technical data

Data at $T_a = 25\text{ °C}$, $U_{in} = 230\text{ V AC}$ and rated values, unless otherwise indicated

Type		CP-C 24/5.0 CP-S 24/5.0	CP-C 24/10.0 CP-S 24/10.0	CP-C 24/20.0 CP-S 24/20.0
Electrical connection - Input circuit				
Wire size	fine-strand with wire end ferrule	0.2-2.5 mm ² (24-14 AWG)		2.5-10 mm ² (14-8 AWG)
	fine-strand without wire end ferrule			0.5-10 mm ² (20-8 AWG)
	rigid			0.5-16 mm ² (20-6 AWG)
Stripping length		7 mm (0.28 in)		12 mm (0.47 in)
Tightening torque		0.4 Nm		1.2-1.5 Nm
Electrical connection - Output circuit				
Wire size	fine-strand with wire end ferrule	0.12-2.5 mm ² (26-14 AWG)		2.5-10 mm ² (14-8 AWG)
	fine-strand without wire end ferrule			0.5-10 mm ² (20-8 AWG)
	rigid			0.5-16 mm ² (20-6 AWG)
Stripping length		8 mm (0.31 in)		12 mm (0.47 in)
Tightening torque		0.4 Nm		1.2-1.5 Nm
Environmental data				
Ambient temperature range	operation	-25...+70 °C		
	rated load	0...+60 °C (without derating)		
	storage	-40...+85 °C		
Damp heat (IEC/EN 60068-2-3)		93 % at +40 °C, no condensation		
Climatic category (IEC/EN 60721)		3K3		
Vibration (IEC/EN 60068-2-6)				
Shock (IEC/EN 60068-2-27)				
Isolation data				
Rated insulation voltage U_i between all isolated circuits (IEC/EN 60950-1; EN 50178)	input / output	300 V		
	input / PE	300 V		
	output / PE	50 V		
Rated impulse withstand voltage U_{imp} between all isolated circuits (IEC/EN 60950-1; EN 50178)	input / output	4 kV; 1.2/50 μ s		
	input / PE	2.5 kV; 1.2/50 μ s		
	output / PE	500 V; 1.2/50 μ s		
Power-frequency withstand voltage test (test voltage) (routine test / type test)	input / output	1.5 kV AC / 3.0 kV AC		
	input / PE	1.5 kV AC / 3.0 kV AC		
	output / PE	500 V DC / 500 V DC		
Pollution degree (IEC/EN 60950-1; EN 50178)		2		
Overvoltage category (IEC/EN 60950-1; EN 50178)		II		
Standards				
Product standard		IEC/EN 61204		
Low Voltage Directive		2006/95/EC		
EMC Directive		2004/108/EC		
Electrical safety		EN 50178, EN 60950, UL 60950, UL 508		
Protective low voltage		SELV (EN 60950)		
Electromagnetic compatibility				
Interference immunity to		IEC/EN 61000-6-2		
electrostatic discharge	IEC/EN 61000-4-2	Level 4 (8 kV / 15 kV)		
radiated, radio-frequency, electromagnetic field	IEC/EN 61000-4-3	Level 3 (10 V/m)		
electrical fast transient / burst	IEC/EN 61000-4-4	Level 4 (4 kV)		
surge	IEC/EN 61000-4-5	Level 4 (2 kV symmetrical, level 3 - 3 kV asymmetrical)		
conducted disturbances, induced by radio-frequency fields	IEC/EN 61000-4-6	Level 3 (10 V)		
Interference emission		IEC/EN 61000-6-3		
high-frequency radiated	IEC/CISPR 22; EN 55022	Class B		
high-frequency conducted	IEC/CISPR 22; EN 55022	Class B		

¹⁾ at $U > 264\text{ V}$ use additionally an appropriate external fuse

²⁾ with lateral screw



³⁾ pluggable connecting terminals, actuate only when power is off

„Approvals and marks“ on page 3/4.

CP-S and CP-C

Technical data

Data at $T_a = 25\text{ °C}$, $U_{in} = 230\text{ V AC}$ and rated values, unless otherwise indicated

Type	CP-C MM	
Input circuit - Supply circuit		
Rated input voltage U_n	110-240 V AC / 100-350 V DC	
Input voltage range	70-264 V AC / 80-350 V DC	
Power consumption	2.5 VA / 1.5 W	
Input circuit - Control circuit		
Kind of triggering	volt-free triggering	
Control input, control function	Remote OFF	remote off
Threshold "Switching-off power supply unit"	$R \leq 1\text{ k}\Omega$	
Threshold "Switching-on power supply unit"	$R \geq 10\text{ k}\Omega$	
Input current	typ. 1 mA (200 mA for 200 μ s)	
Maximum cable length to the control input	25 m - 100 pF/m	
Measuring circuit - INPUT		
powered by the input circuit of the power supply unit		
Monitoring function	undervoltage monitoring of input voltage of the power supply unit	
Thresholds	85 V AC / 90 V DC	
Hysteresis, related to the threshold value	AC: typ. -8 % / DC -30 %	
Accuracy, tolerance	-5 % at AC and DC	
Maximum measuring cycle	typ. < 50 ms	
Measuring circuit - OUTPUT		
powered by the output circuit of the power supply unit		
Monitoring function	undervoltage monitoring of output voltage of the power supply unit	
Thresholds	20 V DC	
Hysteresis, related to the threshold value	typ. 5 %	
Accuracy, tolerance	$\pm 1\%$	
Maximum measuring cycle	typ. < 10 ms	
Indication of operational states		
Remote off	REMOTE OFF: green LED	 : „REMOTE OFF“ input $R \leq 1\text{ k}\Omega$
Status of power supply input	Input OK: green LED	 : relay „INPUT OK“ energized
Status of power supply output	OUTPUT OK: green LED	 : relay „OUTPUT OK“ energized
Output circuits		
11-12/14, 21-22/24		
Kind of output	relays, 2 x 1 c/o contacts	
Operating principle	closed-circuit principle	
Contact material	AgNi	
Rated voltage (VDE 0110, IEC/EN 60947-1)	250 V	
Minimum switching voltage / Minimum switching current	24 V / 10 mA	
Maximum switching voltage / Maximum switching current	250 V / 1 A	
Rated operating current I_o (IEC/EN 60947-1)	AC12 (resistive) at 230 V	1 A
	AC15 (inductive) at 230 V	1 A
	DC12 (resistive) at 24 V	1 A
	DC13 (inductive) at 24 V	1 A
Mechanical lifetime	30 x 10 ⁶ switching cycles	
Electrical lifetime	0.1 x 10 ⁶ switching cycles	
Short circuit proof, maximum fuse rating	n/c contact	2 A, gL
	n/o contact	2 A, gL
General data		
Duty time	100 %	
Dimensions (W x H x D, when mounted)	56.5 x 54 x 24 mm (2.22 x 2.13 x 0.94 in)	
Weight	0.065 kg (0.14 lb)	
Degree of protection	housing / terminals	IP20 / IP20
Material of housing	Plastic	
Protection class (EN 61140)	II	
Mounting	snap-on mounting, without any tool	
Mounting position	plugged onto the power supply unit	
Electrical connection		
Wire size	fine-strand with wire end ferrule	0.2-2.5 mm ² (24-14 AWG)
	fine-strand without wire end ferrule	
	rigid	0.2-4 mm ² (24-12 AWG)
Stripping length	7.5 mm (0.3 inch)	
Tightening torque	0.4-0.6 Nm	

CP-S and CP-C

Technical data

Data at $T_a = 25\text{ °C}$, $U_{in} = 230\text{ V AC}$ and rated values, unless otherwise indicated

Type	CP-C MM	
Environmental data		
Ambient temperature range	operation	-25...+70 °C
	storage	-40...+85 °C
Damp heat (IEC/EN 60068-2-3)		93 % at +40 °C, no condensation
Climatic category (IEC/EN 60721)		3K3
Vibration (IEC/EN 60068-2-6)		
Shock (IEC/EN 60068-2-27)		
Isolation data		
Rated insulation voltage U_i (IEC/EN 60974-1, EN 50178, VDE 0160)		250 V
Protective separation (EN 50178, EN 60950) supply / measuring circuits / relay outputs		yes
Rated impulse withstand voltage U_{imp} between all isolated circuits (IEC 664, VDE 0110)		4 kV; 1.2/50 μ s
Test voltage between all circuits (type test)		2.5 kV AC
Pollution degree (EN 60950)		2
Overvoltage category (EN 60950)		II
Standards		
Product standard		IEC/EN 61204
Low Voltage Directive		2006/95/EC
EMC Directive		2004/108/EC
Electrical safety		EN 50178, EN 60950, UL 60950, UL 508
Elektromagnetic compatibility		
Interference immunity to		IEC/EN 61000-6-2
electrostatic discharge	IEC/EN 61000-4-2	Level 3 and 4 (6 kV / 8 kV)
radiated, radio-frequency, electromagnetic field	IEC/EN 61000-4-3	Level 3 (10 V/m)
electrical fast transient / burst	IEC/EN 61000-4-4	Level 4 and 2 (4 kV power input / 1 kV control input)
surge	IEC/EN 61000-4-5	Level 3 and 2 (4 kV symmetrical power input / 1 kV control input)
conducted disturbances, induced by radio-frequency fields	IEC/EN 61000-4-6	Level (10 V)
Interference emission		IEC/EN 61000-6-3
high-frequency radiated	IEC/CISPR 22; EN 55022	Class B
high-frequency conducted	IEC/CISPR 22; EN 55022	Class B

„Approvals and marks“ on page 3/4.

CP-S and CP-C

Technical diagrams, Dimensional drawings

Technical diagrams

Output curve at 25 °C

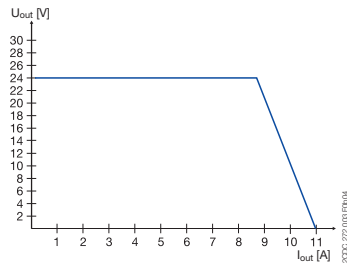

CP-S 24/5.0

Output curve at 25 °C

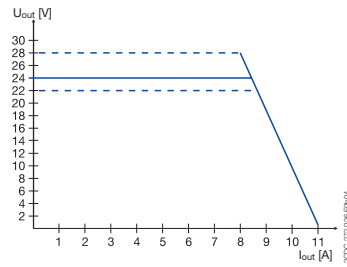

CP-C 24/5.0

Temperature curve at $U_{out} = 24\text{ V DC}$

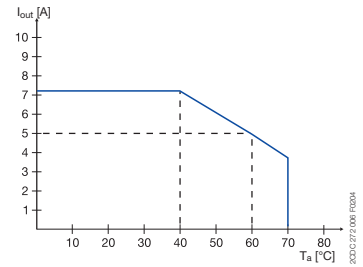

CP-S 24/5.0, CP-C 24/5.0

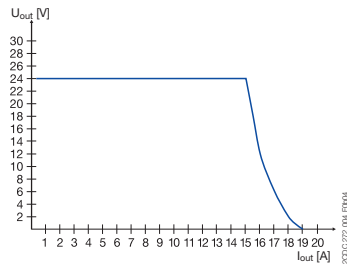

CP-S 24/10.0

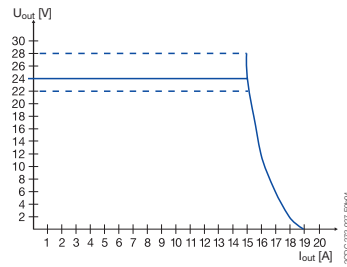

CP-C 24/10.0

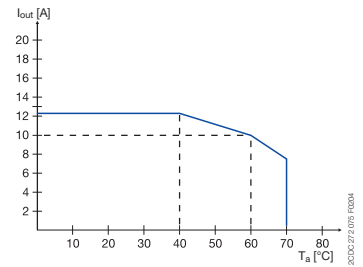

CP-S 24/10.0, CP-C 24/10.0

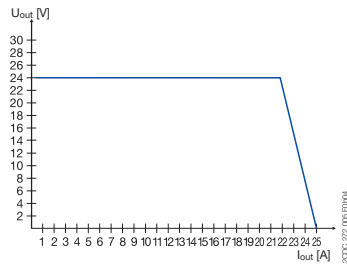

CP-S 24/20.0

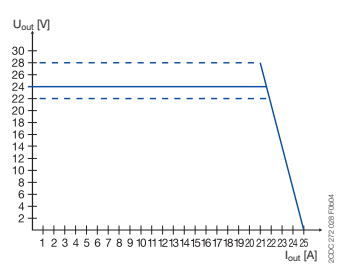

CP-C 24/20.0

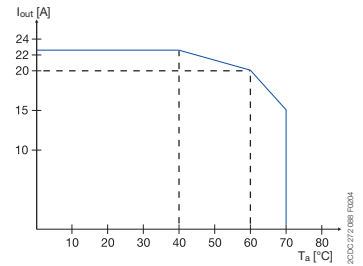

CP-S 24/20.0, CP-C 24/20.0

Dimensional drawings

dimensions in mm

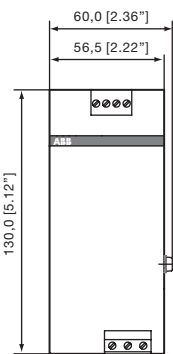
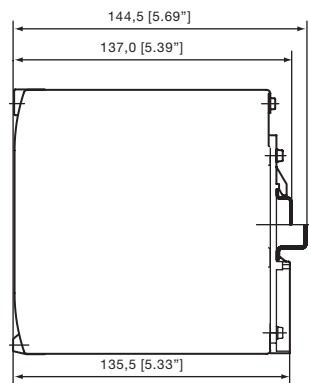

CP-S 24/5.0
CP-C 24/5.0
CP-A RU

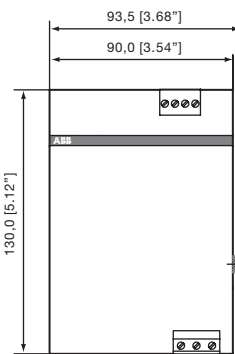

CP-S 24/10.0
CP-C 24/10.0

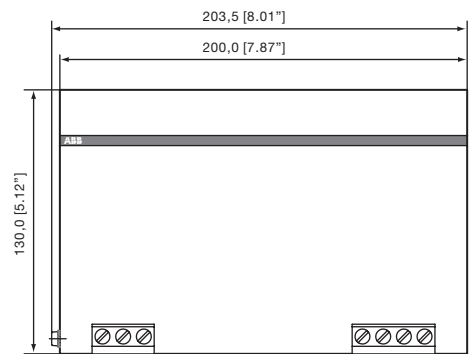

CP-S 24/20.0
CP-C 24/20.0

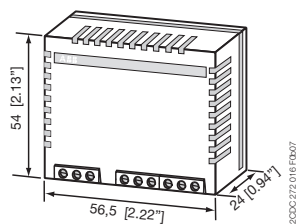

CP-C MM

Redundancy units

Ordering details

3



2CDC 271 008 F0005

CP-A RU + CP-A CM



2CDC 271 010 F0006

CP-A RU



2CDC 271 006 F0003

CP-RUD



2CDC 271 010 F0006

CP-D RU

Ordering details

Description	suitable for decoupling of two CP-24 V DC power supply units or suitable for decoupling of CP-E power supply units	Type	Order code	Price 1 pce	Weight (1 pce) kg (lb)
2 inputs each up to 20 A and 1 output up to 40 A	≤ 40 V and ≥ 5 A	CP-A RU	1SVR427071R0000		0.89 (1.96)
Control module for CP-A RU redundancy units	-	CP-A CM	1SVR427075R0000		0.063 (0.14)
2 inputs each up to 2.5 A and 1 output up to 5 A	≤ 35 V and < 5 A	CP-RUD	1SVR423418R9000		0.15 (0.33)

Ordering details - CP-D RU for decoupling of two CP-D power supply units

Input voltage range	Rated input current	Rated output voltage / current	Type	Order code	Price	Weight (1 pce) kg (lb)
9-35 V DC	2 x 5 A	24 V DC / 1 x 10 A	CP-D RU	1SVR427049R0000		0.075 (0.165)

Redundancy units

Technical data

Type	CP-A RU		CP-A RU in combination with CP-A CM
Input circuit - Supply circuit	(+/-, +/-)		
Rated input voltage U_{in}	24 V DC		
Input voltage range per channel	10-28 V DC	13-28 V DC	
Rated input current I_{in} per channel	1-20 A		
Maximum input current per channel	30 A for 300 s		
Transient overvoltage protection	yes		
Output circuit	(++/--)		
Rated output voltage U_{out}	24 V DC		
Voltage drop	typ. 0.6 V, max. 0.9 V		
Rated output current I_{out}	1-40 A		
Output ratings per channel	$T_a = 60\text{ °C}$	10-28 V DC / 40 A	13-28 V DC / 40 A
	$T_a = 70\text{ °C}$	10-28 V DC / 30 A	13-28 V DC / 30 A
Derating	$60\text{ °C} < T_a \leq 70\text{ °C}$	2.5 % per Kelvin temperature increase	
Peak output current	60 A for 300 s		
Resistance to reverse feed	< 40 V		
General data			
Dimensions (W x H x D)	56.5 (60 ¹⁾) x 130 x 135.5 mm; (2.22 (2.36 ¹⁾) x 5.12 x 5.35 in)		
Weight	0.89 kg (1.96 lb)		
Minimum distance to other units	horizontal / vertical	10 mm / 50 mm (0.39 in / 1.97 in)	
Degree of protection	housing / terminals	IP20 / IP20	
Material of housing	housing shell / cover	aluminium / zinc-coated sheet steel	
Protection class		III ²⁾	
Mounting		DIN rail (IEC/EN 60715)	
Mounting position		horizontal	
Electrical connection - Input circuit / Output circuit			
Wire size	fine-strand with wire end ferrule	2.5-10 mm ² (14-8 AWG)	
	fine-strand without wire end ferrule	0.5-10 mm ² (20-8 AWG)	
	rigid	0.5-16 mm ² (20-6 AWG)	
Stripping length		12 mm (0.47 in)	
Tightening torque		1.2-1.5 Nm	
Environmental data			
Ambient temperature range	operation	-25...+70 °C	
	rated load	-25...+60 °C (without derating)	
	storage	-40...+85 °C	
Damp heat (IEC/EN 60068-2-3)		93 % at 40 °C, no condensation	
Climatic category (IEC/EN 60721)		3K3	
Vibration (IEC/EN 60068-2-6)			
Shock (IEC/EN 60068-2-27)			
Isolation data			
Insulation voltage	between input / output / housing	500 V AC (routine test)	
Pollution degree (EN 50178)		2	
Standards			
Product standard		IEC/EN 61204	
Low Voltage Directive		2006/95/EC	
EMC Directive		2004/108/EC	
Electrical safety		EN 50178, EN 60950, UL 60950, UL 508	
Electromagnetic compatibility			
Interference immunity to		IEC/EN 61000-6-2	
electrostatic discharge	IEC/EN 61000-4-2	Level 3 (air discharge ±8 kV, contact discharge ±6 kV)	
radiated, radio-frequency, electromagnetic field	IEC/EN 61000-4-3	Level 3 (10 V/m)	
electrical fast transient / burst	IEC/EN 61000-4-4	Level 3 (±2 kV)	
surge	IEC/EN 61000-4-5	Level 1 (±0.5 kV)	
conducted disturbances, induced by radio-frequency fields	IEC/EN 61000-4-6	Level 3 (10 V)	
Interference emission		IEC/EN 61000-6-3	
high-frequency radiated	IEC/CISPR 22 / EN 55022	Class B	
high-frequency conducted	IEC/CISPR 22 / EN 55022	Class B	



¹⁾ incl. lateral screw

²⁾ This device is designed for connection to a safety extra-low voltage source. If no safety extra-low voltage is used at the input side, the lateral screw can be used for grounding of the housing (protection class I).

„Approvals and marks“ on page 3/4.

Redundancy units

Technical data

Type	CP-A CM	
Input circuit - Supply circuit		
Rated input voltage U _n		24 V DC
Input voltage range		13-28 V DC
Rated input current	at rated sense load and 24 V DC	120 mA
Power consumption	at 24 V DC	approx. 1 W
Measuring circuit		
Monitoring function		11-12/14, 21-22/24 undervoltage monitoring
Measuring voltage		rated operational voltage
Thresholds		14-28 V
Hysteresis, related to the threshold value		fix: 3-5 %
Accuracy, tolerance		10 % of full-scale value
Maximum measuring cycle		6 ms
Indication of operational states		
Status of input 1	IN 1: green LED	 L: voltage at input 1 > than threshold 1 = no faults present
Status of input 2	IN 2: green LED	 L: voltage at input 2 > than threshold 2 = no faults present
Output status	OUT: green LED	 L: U _{OUT} > 3 V = no faults present
Output circuit		
Kind of output		relays, 2 x 1 c/o contact
Contact material		AgNi
Operating principle		closed-circuit principle
Rated operational voltage U _e (IEC/EN 60947-1, VDE 0110)		250 V
Minimum switching voltage / Minimum switching current		24 V / 10 mA
Maximum switching voltage / Maximum switching current		250 V / 1 A
Rated operational current I _e (IEC/EN 60947-5-1)	AC12 (resistive) at 230 V	1 A
	AC15 (inductive) at 230 V	1 A
	DC12 (resistive) at 24 V	1 A
	DC13 (inductive) at 24 V	1 A
Mechanical lifetime		30 x 10 ⁶ switching cycles
Electrical lifetime		0.1 x 10 ⁶ switching cycles
Rating according UL 508	General purpose (GP) 250 V AC	1 A
Maximum fuse rating to achieve short-circuit protection	n/o contact	2 A, gL
	n/c contact	2 A, gL
Sense output (+, +, -)		
Sense output voltage		1 SVR 427 075 R0000 13-28 V DC
Sense output current		0.1 A
Maximum fuse rating		For applications acc. UL the sense output shall be provided with a listed DC fuse 3 A
General data		
Duty time		100 %
Dimensions (W x H x D, when mounted)		56.5 x 54 x 24 mm (2.22 x 2.13 x 0.94 in)
Material of housing		plastic
Weight		0.063 kg (0.14 lb)
Degree of protection	housing / terminals	IP20 / IP20
Protection class		II
Mounting		snap-on mounting, without any tool
Mounting position		plugged onto the redundancy unit CP-A RU
Electrical connection		
Wire size	fine-strand with wire end ferrule	0.2-2.5 mm ² (24-14 AWG)
	fine-strand without wire end ferrule	
	rigid	0.2-4 mm ² (24-12 AWG)
Stripping length		7.5 mm (0.3 in)
Tightening torque		0.4-0.6 Nm
Isolation data		
Rated insulation voltage U _i (IEC/EN 60947-1, EN 50178, VDE 0160)		250 V
Rated impulse withstand voltage U _{imp} (type test) between all circuits (IEC 664, VDE 0110)		2.5 kV
Power-frequency withstand voltage test (routine test) between all circuits		1.2 kV AC
Protective separation (EN 50178) between input and output		yes
Pollution degree		2
Overvoltage category		II
Environmental data		
Ambient temperature range	operation	-25...+70 °C
	storage	-40...+85 °C
Damp heat (IEC/EN 60068-2-3)		93 % at 40 °C, no condensation
Climatic category (IEC/EN 60721)		3K3
Vibration (IEC/EN 60068-2-6)		
Shock (IEC/EN 60068-2-27)		

Redundancy units

Technical data

Type		CP-RUD
Input circuit - Supply circuit		A: U1+/-U ; B: U2+/-U
Rated input voltage U_{in}		24 V DC
Input voltage range		5-35 V DC
Rated input current I_{in} per channel		0.5-2.5 A
Maximum input current per channel		10 A for 300 s
Transient overvoltage protection		no
Output circuit		L+, L+, L+, L-, L-, L-
Rated output voltage U_{out}		24 V DC
Voltage drop		typ. 0.6 V, max. 0.7 V
Rated output current I_{out}		0.5-5 A
Peak output current		20 A for 150 s
Resistance to reverse feed		< 35 V
General data		
Dimensions (W x H x D)		22.5 x 78 x 100 mm (0.89 x 3.07 x 4.02 in)
Weight		0.135 kg (0.30 lb)
Minimum distance to other units	horizontal / vertical	10 mm / 10 mm (0.39 in / 0.39 in)
Degree of protection	housing / terminals	IP20 / IP20
Material of housing	housing shell / cover	plastic / plastic
Protection class		-
Mounting		DIN rail (IEC/EN 60715)
Mounting position		horizontal
Electrical connection - Input circuit / Output circuit		
Wire size	fine-strand with wire end ferrule	2 x 0.75-2.5 mm ² (2 x 18-14 AWG)
	fine-strand without wire end ferrule	
	rigid	2 x 0.5-4 mm ² (2 x 20-12 AWG)
Stripping length		7 mm (0.28 in)
Tightening torque		0.6-0.8 Nm
Environmental data		
Ambient temperature range	operation	-20...+60 °C
	rated load	-20...+60 °C
	storage	-40...+85 °C
Damp heat (IEC/EN 60068-2-3)		93 % at 40 °C, no condensation
Climatic category (IEC/EN 60721)		-
Vibration (IEC/EN 60068-2-6)		-
Shock (IEC/EN 60068-2-27)		-
Isolation data		
Insulation voltage	between input / output / housing	-
Pollution degree (EN 50178)		2
Standards		
Product standard		
Low Voltage Directive		2006/95/EC
EMC Directive		2004/108/EC
Electrical safety		EN 50178
Electromagnetic compatibility		
Interference immunity to		IEC/EN 61000-6-2
electrostatic discharge	IEC/EN 61000-4-2	Level 3 (air discharge ±8 kV, contact discharge ±6 kV)
radiated, radio-frequency, electromagnetic field	IEC/EN 61000-4-3	Level 3 (10 V/m)
electrical fast transient/burst	IEC/EN 61000-4-4	Level 3 (±2 kV)
surge	IEC/EN 61000-4-5	Level 1 (±0.5 kV)
conducted disturbances, induced by radio-frequency fields	IEC/EN 61000-4-6	Level 3 (10 V)
Interference emission		IEC/EN 61000-6-3
high-frequency radiated	IEC/CISPR 22 / EN 55022	Class B
high-frequency conducted	IEC/CISPR 22 / EN 55022	Class B

¹⁾ incl. lateral screw

²⁾ This device is designed for connection to a safety extra-low voltage source. If no safety extra-low voltage is used at the input side, the lateral screw can be used for grounding of the housing (protection class I).

Redundancy units

Technical data

3

Type		CP- D RU
Input circuit - Supply circuit		IN 1 + + -, IN 2 + + -
Rated input voltage U_{in}		24 V DC
Input voltage range		9-35 V DC
Rated input current I_{in} per channel		5 A
Maximum input current per channel		10 A for 300 s
Transient overvoltage protection		no
Output circuit		OUT + + +, - - -
Rated output voltage U_{out}		24 V DC
Voltage drop		typ. 0.5 V
Rated output current I_{out}		10 A
Resistance to reverse feed		< 35 V
General data		
MTBF		on request
Duty time		100 %
Dimensions (W x H x D)	product dimensions	35 x 91 x 56.5 mm (1.38 x 3.58 x 2.22 in)
	packaging dimensions	134 x 94 x 48 mm (5.28 x 3.70 x 1.89 in)
Weight	net weight	0.075 kg (0.165 lb)
	gross weight	0.130 kg (0.286 lb)
Material of housing		plastic
Mounting		DIN rail, snap-on mounting without any tool
Mounting position		horizontal
Minimum distance to other units	horizontal / vertical	25 mm (0.98 in) / 25 mm (0.98 in)
Electrical connection - Input circuit / Output circuit		
Wire size	fine-strand with (out)	0.2-2.5 mm ² (24-14 AWG)
	wire end ferrule	
	rigid	0.2-2.5 mm ² (24-12 AWG)
Stripping length		7.0 mm (0.28 in)
Tightening torque		0.67 Nm (6 lb.in)
Environmental data		
Ambient temperature range	operation	-40...+70 °C
	storage	-40...+85 °C
Relative humidity	RH at 40 °C	20-95 %, no condensation
Vibration (IEC/EN 60068-2-6)		Mounting by rail: 10-500 Hz, 2 G, along X, Y, Z each axis, 60 min for each axis
Shock (IEC/EN 60068-2-27)		15 G, 11 ms, 3 axis, 6 faces, 3 times for each face
Standards		
Product standard		IEC/EN 61204-3
Low Voltage Directive		2006/95/EC
EMC Directive		2004/108/EC
RoHS Directive		2002/95/EC
Electromagnetic compatibility		
Interference immunity to		EN 55024
electrostatic discharge	IEC/EN 61000-4-2	Level 3, air discharge 8 kV, contact discharge 4 kV
radiated, radio-frequency, electromagnetic field	IEC/EN 61000-4-3	Level 3, 10 V/m
electrical fast transient/burst	IEC/EN 61000-4-4	Level 3, 2 kV / 5 kHz
conducted disturbances, induced by radio-frequency fields	IEC/EN 61000-4-6	Level 3, 10 V
Interference emission		EN 55022
high-frequency radiated	IEC/CISPR 22 / EN 55022	Class B
high-frequency conducted	IEC/CISPR 22 / EN 55022	Class B

Redundancy units

Dimensional drawings

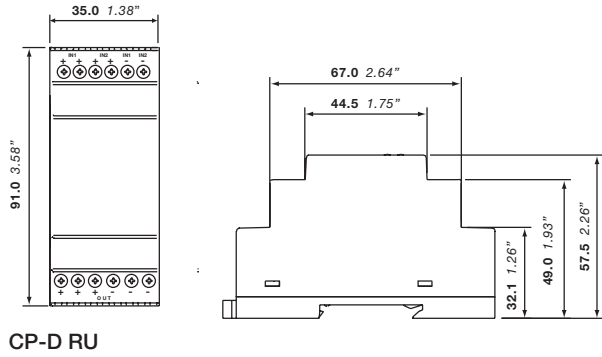

CP-D RU

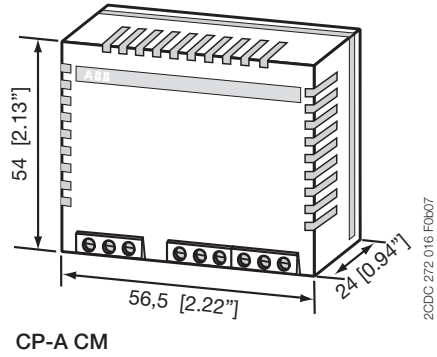

CP-A CM

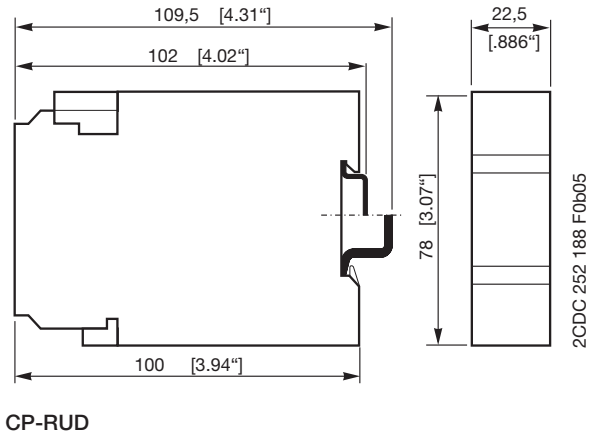

CP-RUD

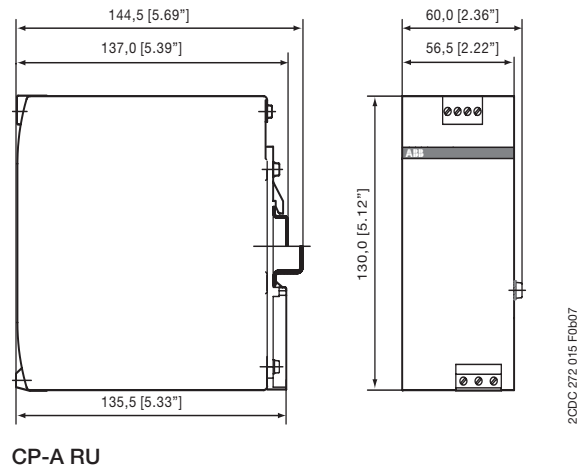

CP-A RU

CP-ASI range

Product group picture

3



CP-ASI range

Table of contents

CP-ASI	
Product group picture	3/57
Table of contents	3/58
Benefits and advantages	3/59
Ordering details	3/60
Technical data	3/61
Technical diagrams	3/63
Dimensional drawings	3/64

CP-ASI range

Benefits and advantages

Characteristics

- Rated output voltage 30.5 V DC for ASI-bus
- Rated output current up to 8.0 A
- High efficiency of up to 92 % ¹⁾
- Infrared addressing mode ²⁾
- Low power dissipation and low heating
- Free convection cooling (no forced cooling with ventilators)
- Ambient temperature range during operation -10...70 °C ³⁾
- Open-circuit, overload and short-circuit stable
- Integrated input fuse
- Tool-free mounting on DIN rail as well as demounting
- LEDs for the indication of operational states

■ Approval:  / Mark: 

¹⁾ Efficiency is depending on device

²⁾ Except CP-ASI/4,0 DC/DC

³⁾ Ambient temperature range CP-ASI/4,0 DC/DC -25...70°C

⁴⁾ Approvals are related to rated input voltage U_{in}

3

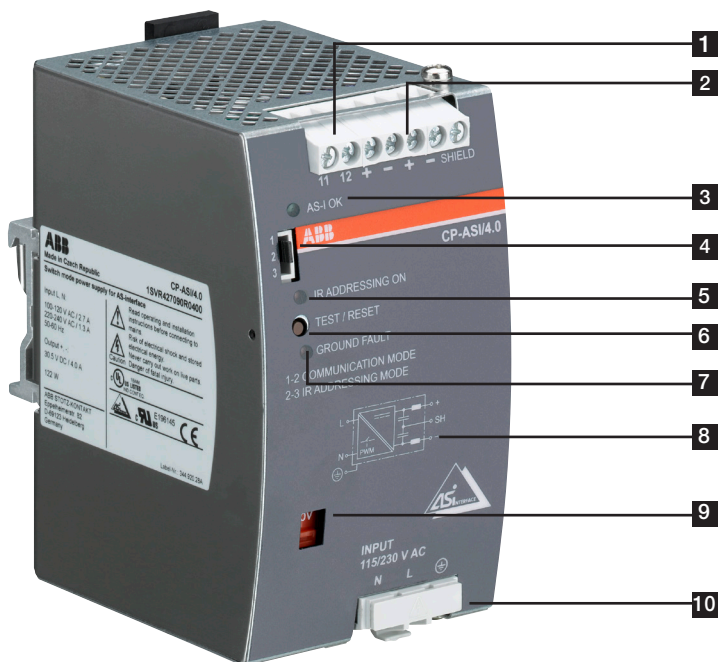

- 1 Output +, -, +, -, SHIELD: output terminals
- 2 Signalling contact 11-12: ground fault signalling terminals
- 3 Indication of operational states
ASI OK: green LED - output voltage OK
- 4 Configuration of operation mode Jumper
- 5 Indication of operational states
IR ADDRESSING ON: red LED - infrared addressing mode active
- 6 Test and reset button
- 7 Indication of operational states
GROUND FAULT: red LED - ground fault detected
- 8 Circuit diagram
- 9 Input voltage selector Adjustment of input voltage
- 10 Input L, N, PE: input terminals

CP-ASI range

Ordering details



2CDC 271 002 S0012

CP-ASI/2.8



2CDC 271 003 S0012

CP-ASI/4.0 DC/DC



2CDC 271 004 S0012

CP-ASI/4.0



2CDC 271 005 S0012

CP-ASI/8.0

Description

The CP-ASI power supply range is specifically designed with integrated data decoupling for the supply of AS-Interface systems.

Up to 62 slaves (binary I/O devices) can be supplied with a single two-conductor cable.

The configurable IR addressing mode allows the easy assign of new ID addresses by means of an external infrared programming unit.

Ordering details

Input Voltage Range	Rated Output Voltage	Rated Output Current	Type	Order code	Price 1 pce	Weight (1 pce) kg (lb)
85-132 V AC, 184-264 V AC	30.5 V DC	2.8 A	CP-ASI/2.8	1SVR427090R0280		0.495 (1.091)
85-132 V AC, 184-264 V AC	30.5 V DC	4.0 A	CP-ASI/4.0	1SVR427090R0400		0.653 (1.440)
18-32.4 V DC	30.5 V DC	4.0 A	CP-ASI/4.0 DC/DC	1SVR427095R0400		0.488 (1.076)
85-132 V AC, 184-264 V AC	30.5 V DC	8.0 A	CP-ASI/8.0	1SVR427090R0800		0.897 (1.978)

CP-ASI range

Technical data

Data at $T_a = 25\text{ }^\circ\text{C}$, $U_{in} = 230\text{ V AC}$ and rated values, unless otherwise indicated

Type	CP-ASI/2.8	CP-ASI/4.0	CP-ASI/8.0	CP-ASI/4.0 DC/DC
Input circuit - Supply circuit	L, N			
Rated input voltage U_{in}	-	-	-	24 V DC
	switch position 115 V	100-120 V AC	-	-
	switch position 230 V	220-240 V AC	-	-
Input voltage range	-	-	-	18.0-32.4 V DC
	switch position 115 V	85-132 V AC	-	-
	switch position 230 V	184-264 V AC	184-264 V AC / 240-300 V DC	184-264 V AC
Frequency range AC	47-63 Hz	-	-	-
Typical input current	-	-	-	5.6 A
	switch position 115 V	2.0 A	2.7 A	6.0 A
	switch position 230 V	0.9 A	1.3 A	2.8 A
Allowed voltage between input and earth (ground)	-	-	-	max. 60 V DC / 42.4 V AC
Allowed input ripple voltage	-	-	-	max. 5 Vpp, 47 Hz - 40 kHz
Continuous input voltage with no damage to the DC/DC converter	-	-	-	max. 36.0 V DC
Turn-on voltage	-	-	-	typ. 17.5 V DC
Shut-down voltage	-	-	-	typ. 14.0 V DC
	-	-	-	typ. 35 V DC
Typical power consumption	94 W	135 W	261 W	132 W
Inrush current limiting / Ft (cold start)	< 20 A (132 V AC) / approx. 1.5 A ² /s < 38 A (264 V AC) / approx. 1.8 A ² /s	< 44.7 A (120 V AC) / approx. 3.7 A ² /s < 49.3 A (132 V AC) / approx. 4.6 A ² /s < 49.7 A (230 V AC) / approx. 2.5 A ² /s < 57.5 A (264 V AC) / approx. 3.3 A ² /s	< 12 A (100 V AC) / approx. 1.0 A ² /s < 14 A (120 V AC) / approx. 1.5 A ² /s < 24 A (220 V AC) / approx. 1.4 A ² /s < 27 A (240 V AC) / approx. 1.6 A ² /s	< 1.8 A / approx. 1.0 A ² /s
Discharge current towards PE	< 3.5 mA	-	-	-
Power failure buffering time	-	-	-	max. 0.5 ms
	at 115 V AC	min. 35 ms	min. 40 ms	min. 20 ms
	at 230 V AC	min. 40 ms	-	min. 30 ms
Transient overvoltage protection	varistors			
Reverse input polarity protection	-	-	-	included, unit does not start at reversed polarity
Internal input fuse	8 A slow acting / 250 V AC	3.15 A slow acting / 250 V AC	8 A slow acting / 250 V AC	10 A slow acting
External fusing (not necessary, but recommended)	circuit breaker with C characteristic min 6 A, or alternatively 10 A with B characteristic			
Power factor correction (PFC)	at 115 V AC	0.58	0.53	-
	at 230 V AC	0.53	0.48	-
Indication of operational states				
Output voltage	AS-I OK	LED green	-	-
IR addressing mode	IR ADDRESSING ON	LED red	-	-
Overload	OVERLOAD	LED red	-	-
Output circuit	+,-			
Rated output voltage	30.5 V DC			
Rated output power	85 W	122 W	244 W	122 W
Tolerance of the output voltage	± 3 %			
Adjustment range of the output voltage	-			
Rated output current I_o	$T_a \leq 60\text{ }^\circ\text{C}$	2.8 A	4.0 A	8.0 A
Derating of the output current	$60\text{ }^\circ\text{C} < T_a \leq 70\text{ }^\circ\text{C}$	2.5 %/°C	-	-
Signalling contact for ground fault	-	max. 25 V AC or 60 V DC, 0.5 A	-	-
Control time	< 2 ms			
Starting time after applying the supply voltage	max. 400 ms	max. 700 ms	max. 500 ms	max. 1 s (typ. 650 ms)
Rise time	max. 100 ms	-	-	-
	at rated load	-	-	typ. 100 ms
	with 5 mF	-	-	typ. 200 ms
Residual ripple	BW = 500 kHz	typ. < 50 mV _{pp}	-	-
Switching peaks	BW = 20 MHz	typ. < 100 mV _{pp}	-	-
Output circuit - No-load, overload and short-circuit behaviour				
Characteristic curve of output	U/I characteristic curve		Combined U/I characteristic curve and hiccup mode	U/I characteristic curve
Short-circuit protection	continuous short-circuit stability		temporary short-circuit stability	continuous short-circuit stability
Short-circuit behaviour	continuation with output power limiting		-	continuation with output power limiting
Current limiting at short circuit	min / max	3.2 A / 4.6 A	4.2 A / 6.5 A	12 A / 25 A (max. 5 s)
Overload protection	output power limiting		temporary output power limiting	output power limiting

CP-ASI range

Technical data

Data at $T_a = 25\text{ °C}$, $U_{in} = 230\text{ V AC}$ and rated values, unless otherwise indicated

Type		CP-ASI/2.8	CP-ASI/4.0	CP-ASI/8.0	CP-ASI/4.0 DC/DC
Overtemperature, overload and short circuit behaviour		CP-ASI/8.0: at 8.4 A < I_{max} < 12 A continuous current for 2-5 s, afterwards safety switch-off			
Overtemperature protection		CP-ASI/4.0 DC/DC: yes, automatic recovery after temperature went down			
No-load protection		continuous no-load stability			
General data					
MTBF		on request			
Power dissipation		typ. < 9.1 W (230 V AC, 2.8 A)	typ. < 13.5 W (230 V AC, 4.0 A)	typ. < 21.2 W (230 V AC, 8.0 A)	typ. < 12.7 W (24 V DC, 4.0 A)
Efficiency		typ. 90.5 %	typ. 90 %	typ. 92.0 %	typ. 90.5 %
Duty time		100 %			
Dimensions (W x H x D)	product dimensions	49 x 131 x 107 mm (1.93 x 5.16 x 4.21 in)	73 x 131 x 107 mm (2.87 x 5.16 x 4.21 in)	91 x 131 x 107 mm (3.58 x 5.16 x 4.21 in)	40 x 131 x 107 mm (1.58 x 5.16 x 4.21 in)
	packaging dimensions	151 x 65 x 140 mm (5.94 x 2.56 x 5.51 in)	151 x 98 x 140 mm (5.94 x 3.86 x 5.51 in)	151 x 120 x 140 mm (5.94 x 4.72 x 5.51 in)	151 x 65 x 140 mm (5.94 x 2.56 x 5.51 in)
Weight	net weight	0.495 kg (1.019 lb)	0.653 kg (1.440 lb)	0.897 kg (1.997 lb)	0.488 kg (1.076 lb)
	gross weight	0.568 kg (1.252 lb)	0.750 kg (1.653 lb)	1.015 kg (2.238 lb)	0.750 kg (1.287 lb)
Material of housing		metal			
Mounting		DIN rail (IEC/EN 60715), snap-on mounting without any tool			
Mounting position		horizontal			
Minimum distance to other units	horizontal / vertical	15 mm / 25 mm (0.59 / 0.99 in)			
Degree of protection	housing / terminals	IP20 / IP20			
Protection class		I			
Electrical connection					
Wire size	fine-strand with wire end ferrule	0.5-4 mm ² (20-12 AWG)			
	fine-strand without wire end ferrule	0.5-4 mm ² (20-12 AWG)			
Stripping length	rigid	0.5-6 mm ² (20-10 AWG)			
		7 mm (0.28 in)			
Tightening torque		0.8 Nm (7.08 lb.in)			
Environmental data					
Ambient temperature range	operation	-10...+70 °C			-25...+70 °C
	rated load	-10...+60 °C			-25...+60 °C
	storage	-25...+85 °C			-40...+85 °C
Vibration (sinusoidal) (IEC/EN 60068-2-6)		2-17.8 Hz, amplitude ± 1.6 mm			
	sinusoidal (IEC/EN 60068-2-6)	17.8 Hz - 500 Hz, 2 g			
	random (IEC 60068-2-64)	2-800 Hz 0.5 s ² (s ³)			
Shock (half-sine) (IEC/EN 60068-2-27)		15 g (6 ms), 10 g (11 ms)			
Isolation data					
Rated insulation voltage U_i (IEC/EN 60950-1, EN 50178)	input circuit / output circuit	300 V			50 V
	input / PE	300 V			50 V
	output / PE	50 V			
	shield / output shield / PE	50 V 50 V			
Rated impulse withstand voltage U_{imp} (EN 50178)	input / output	6 kV 1.2/50 µs			1.5 kV 1.2/50 µs
	input / PE	4 kV 1.2/50 µs			0.8 kV 1.2/50 µs
	output / PE	500 V 1.2/50 µs			500 V 1.2/50 µs
Power-frequency withstand voltage test (test voltage) (routine test / type test)	input / output	2.5 kV AC / 3.0 kV AC			1.5 kV AC / 1.5 kV AC
	input / PE	2.5 kV AC / 2.5 kV AC			1.5 kV AC / 1.5 kV AC
	output / PE	500 V AC / 500 V AC			
Pollution degree (IEC/EN 60950-1)		2			
Overvoltage category (UL/IEC/EN 60950-1)	input	II (IEC/EN 60950-1), III (EN 50178)			
	output	II (IEC/EN 60950-1), II (EN 50178)			
Standards					
Low Voltage Directive		2006/95/EC			
EMC directive		2004/108/EC			
RoHS directive		2011/65/EC			
Electrical safety		IEC/EN 60950-1			
Protective low voltage		SELV (IEC/EN 60950-1), PELV			
Electromagnetic compatibility					
Interference immunity to electrostatic discharge	IEC/EN 61000-4-2	IEC/EN 61000-6-2 Level 4 (8 kV / 15 kV)			
		Level 3 (10 V/m)			
radiated, radio-frequency, electromagnetic field	IEC/EN 61000-4-3	Level 3 (10 V/m)			
		Level 3 (10 V/m)			
electrical fast transient/burst	IEC/EN 61000-4-4	input circuit: Level 4 (4 kV) output circuit: Level 3 (2 kV)			input circuit: Level 3 (2 kV) output circuit: Level 2 (1 kV)
		input circuit: Level 4 (4 kV) output circuit: Level 3 (2 kV)			
surge	IEC/EN 61000-4-5	input circuit: L-L Level 3 (2 kV) / L-PE Level 4 (4 kV) output circuit: Level 1 (0.5 kV)			input circuit: L-L Level 2 (1 kV) / L-PE Level 3 (2 kV) output circuit: Level 1 (0.5 kV)
		input circuit: L-L Level 3 (2 kV) / L-PE Level 4 (4 kV) output circuit: Level 1 (0.5 kV)			
conducted disturbances, induced by radio-frequency fields	IEC/EN 61000-4-6	Level 3 (10 V, 150 kHz - 80 MHz)			Level 3 (10 V, 150 kHz - 80 MHz)
		Level 3 (10 V, 150 kHz - 80 MHz)			
voltage dips, short interruptions and voltage variations	IEC/EN 61000-4-11	Class 3			
		Class 3			
Interference emission	IEC/EN 61000-6-3	IEC/EN 61000-6-3			IEC/EN 61000-6-3
		IEC/EN 61000-6-3			
high-frequency radiated	IEC/CISPR 22, EN 55022	Class B			
high-frequency conducted	IEC/CISPR 22, EN 55022	Class B			
limits for harmonic current emissions	IEC/EN 61000-3-2	Class A			

CP-ASI range

Technical diagrams

Characteristic curve at $T_a = 25\text{ °C}$

CP-ASI 2.8

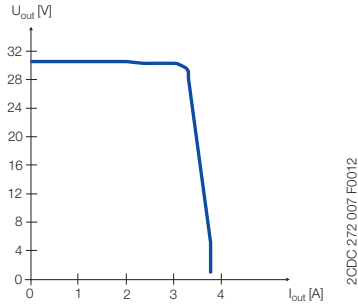

Output behaviour

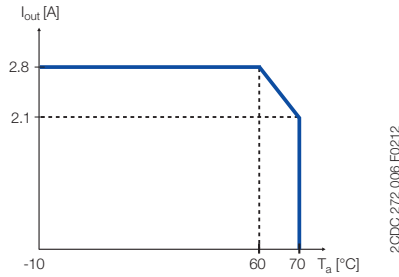

Temperaturkennlinie bei Bemessungslast

CP-ASI 4.0 DC/DC

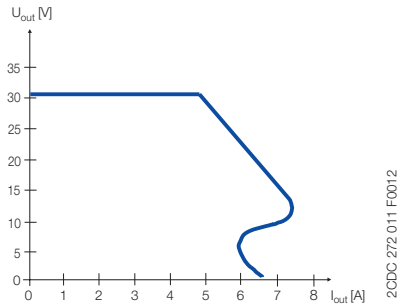

Output behaviour

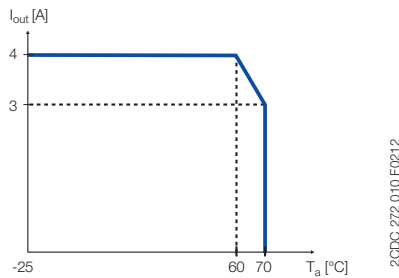

Characteristic curve of temperature at rated load

CP-ASI 4.0

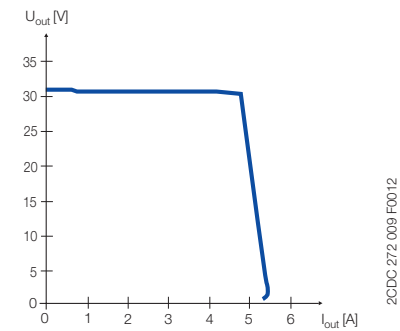

Output behaviour

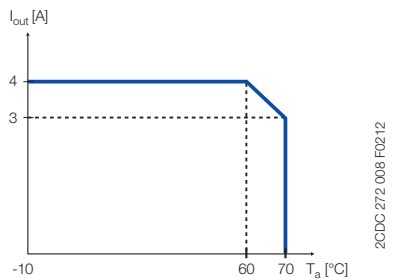

Characteristic curve of temperature at rated load

CP-ASI 8.0

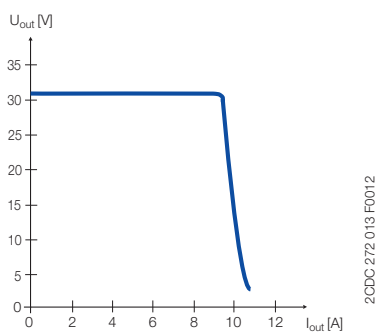

Output behaviour

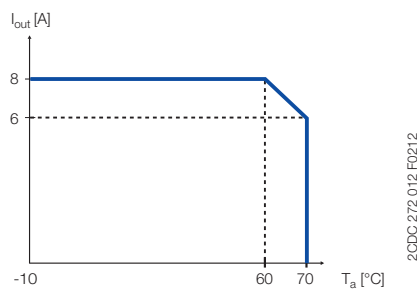

Characteristic curve of temperature at rated load

CP-ASI range

Dimensional drawings

Dimensions in mm/inch

CP-ASI 2.8

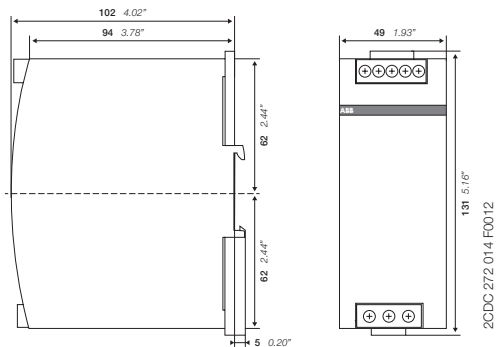

CP-ASI 4.0 DC/DC

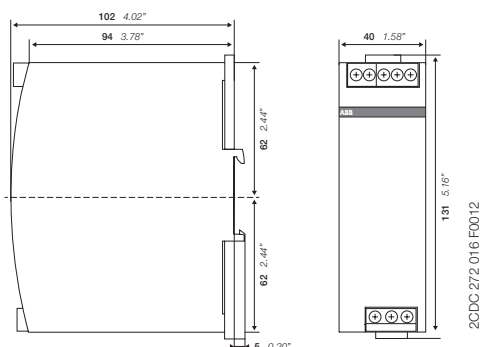

CP-ASI 4.0

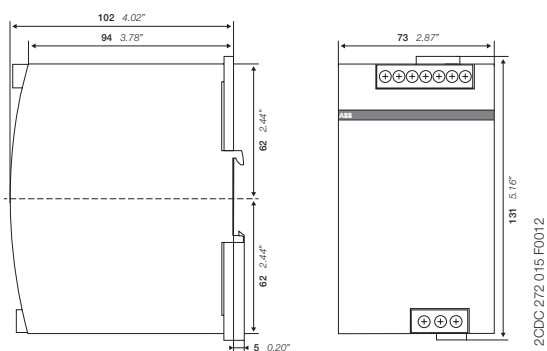

CP-ASI 8.0

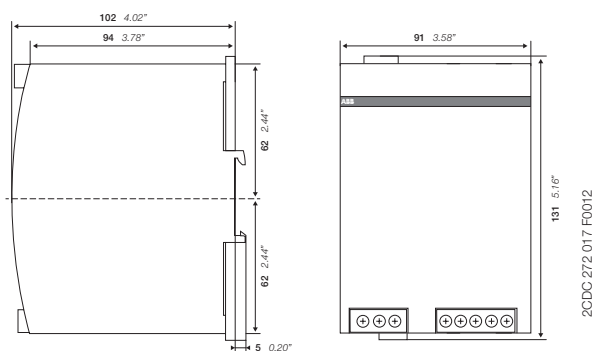

CP-B range Product group picture

3



CP-B range

Table of contents

CP-B	
Product group picture	3/65
Table of contents	3/66
Benefits and advantages	3/67
Ordering details	3/68
Technical data	3/69
Technical data, Technical diagrams	3/70
Dimensional drawings	3/71
Technical data	3/72

CP-B range

Benefits and advantages

Power supply systems have to be highly reliable in most areas of energy management and automation technology.

Often batteries are used for supporting the supply system in case of mains failures. Batteries have limited lifetimes depending on environmental parameters and have to be maintained regularly, which causes efforts and costs.

3

Using the latest ultra-capacitor technology, ABB offers an innovative and completely maintenance free new product for buffering the 24 V DC supply in case of interrupted mains on the primary side of the switch mode power supply.

The CP-B range is an ultra-capacitor buffer energy storage for power supply units which ensures a short term uninterrupted power supply system. In case of a power loss, the energy stored in the capacitor guarantees that the load is continually provided up to several hundred seconds depending on the load current.

Characteristics

- 3 buffer modules for buffering 24 V DC:
CP-B 24/3.0 (3 A / 1 kW^s¹⁾)
CP-B 24/10.0 (10 A / 10 kW^s¹⁾)
CP-B 24/20.0 (20 A / 8 kW^s¹⁾)
- CP-B 24/3.0 and CP-B 24/20.0 expandable with additional extension module(s) CP-B EXT.2 (2 kW^s¹⁾)
- LEDs for status indication
- Relay contacts for status messaging
- Very high backup times (e.g. with CP-B 24/10.0 up to 8 minutes at 1 A load current)
- Short charging times
- High efficiency, higher than 90%
- Wide temperature range
- DIN rail mountable, compact housing

Advantages in comparison to battery buffers:

- Maintenance free
- No deep discharge
- Temperature resistant
-  approval (UL508, CSA22.2 No 14)

¹⁾ internal energy buffer

		CP-B 24/3.0	CP-B 24/10.0	CP-B 24/20.0	CP-B EXT.2
Order code		1SVR427060R0300	1SVR427060R1000	1SVR427060R2000	1SVR427065R0000
Rated input voltage		24 V DC	24 V DC	24 V DC	–
Rated current		3 A DC	10 A DC	20 A DC	3 A DC
Energy storage (min.)		1.000 Ws	10.000 Ws	8.000 Ws	2.000 Ws
Typical charging time at load current	100 %	65 s	134 s	135 s	
	0 %	56 s	82 s	62 s	
Typical buffering time ¹⁾	100 %	13 s	38 s	15 s	
	50 %	28 s	76 s	30 s	
at load current	25 %	66 s	140 s	60 s	
	10 %	148 s	380 s	150 s	

$$^1) \text{ buffering time} \approx \frac{\text{energy storage} \times 0.9}{\text{current} \times \text{output voltage}}$$



1 Input terminals

SHUT-DOWN+, SHUT-DOWN-: Input signal terminals

INPUT OK, BUFFER STATUS, FAILURE: Signalling contact – terminals

L+_{IN}, L-_{IN}: Input voltage terminals

2 Indication of operational states

OPERATION: Buffer module in operation (standby or buffering)

INPUT OK: Input voltage applied

3 Output terminals

L+_{OUT}, L-_{OUT}, L-_{OUT}: Output voltage terminals

CP-B range

Ordering details



CP-B 24/3.0

2CDC 271 001 S0010



CP-B 24/10.0

2CDC 271 002 S0010



CP-B 24/20.0

2CDC 271 003 S0010

Description

Ultra capacitor based buffer units of the CP-B range offer highest reliability also in harsh environment. Due to the ultra-cap based technology the units are maintenance free, there will be no deep discharge and these products offer a very wide operational ambient temperature range.

CP-B range buffer units are an excellent solution to avoid voltage drops, for example in solar applications.

Ordering details

Rated input voltage	Rated current	Type	Order code	Price 1 pce	Weight (1 pce) kg (lb)
24 V DC	3 A DC	CP-B 24/3.0	1SVR427060R0300		0.55 (1.21)
	10 A DC	CP-B 24/10.0	1SVR427060R1000		2.10 (4.63)
	20 A DC	CP-B 24/20.0	1SVR427060R2000		2.20 (4.85)

Ordering details - Extension unit for CP-B 24/3.0 and CP-B 24/20.0

Rated voltage	Voltage range	Type	Order code	Price 1 pce	Weight (1 pce) kg (lb)
24 V DC	0-26.4 V DC	CP-B EXT.2	1SVR427065R0000		1.00 (2.20)

Example of application

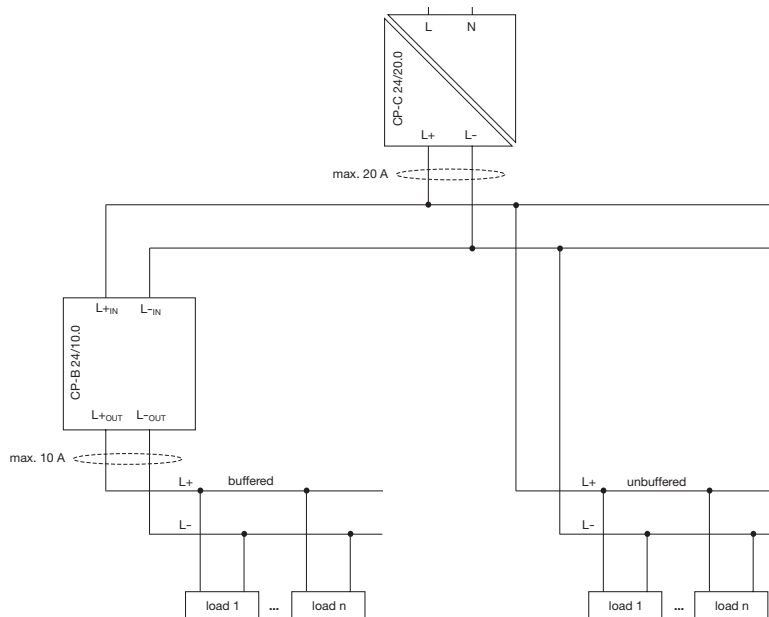

CP-B range

Technical data

Data at $T_a = 25\text{ °C}$ and rated values, unless otherwise indicated

Type		CP-B 24/3.0	CP-B 24/10.0	CP-B 24/20.0
Input circuit - Supply circuit			L+_{IN} L-_{IN}	
Rated input voltage U_{in}		24 V DC		
Input voltage range		23.7-26.4 V DC	23.9-27 V DC	23.4-27.4 V DC
Minimum charging potential		23.7 V DC	23.9 V DC	23.4 V DC
Rated input current		3 A DC	10 A DC	20 A DC
Inrush current limiting		50 A / 1 ms	35 A / 2 ms	35 A / 2 ms
Transient overvoltage protection		suppressor diode	varistor / suppressor diode	varistor / suppressor diode
Internal input fuse (apparatus protection, not accessible)		4 A slow acting	15 A (FK2)	30 A (FK2)
Internal fuse capacitors circuit (not accessible)			25 A (FK2)	
Kind of input	SHUT-DOWN	-	control input	control input
	rated voltage	-	24 V DC	24 V DC
	voltage range	-	6-45 V DC	6-45 V DC
Output circuit			L+_{OUT} L-_{OUT} L-_{OUT}	
Rated output power		69 W	240 W	480 W
Rated output voltage U_{out}		24 V DC		
Output voltage (buffer mode)		23.0 V DC	23.2 V DC	23.2 V DC
Tolerance of the output voltage		+2...-10 %		
Rated output current I	$T_a \leq 60\text{ °C}$	3 A DC	10 A DC	20 A DC
Peak output current (fully loaded capacitors required)	$T_a \leq 60\text{ °C}$	6 A DC (min. 1.5 s)	20 A DC (10 A power supply + 10 A CP-B, min. 1.5 s)	40 A DC (min. 1.5 s)
Control of limiting current		-	10.3 A DC $\pm 0.1A$	-
Shut-down if limiting current is exceeded		-	after 1.5 s	-
Short-circuit protection (only via external fuse)		-	no continuous short-circuit stability	-
Internal output fuse (not accessible)		-	15 A (FK2)	-
Required external fuse		3.15 A slow acting	10 A slow acting	25 A slow acting
Current limiting at output circuit		-	1.05...1.2 x I	-
Breaking capacity of output circuit	$\tau = 2.5\text{ ms}$	-	24 V DC, 10 A	-
Power failure buffering time ¹⁾		load-dependent, min. 13 s at 100 % load	load-dependent, min. 38 s at 100 % load	load-dependent, min. 15 s at 100 % load
Overload protection		thermal protection		
Kind of output	INPUT OK	n/o contact		
	BUFFER STATUS	-	n/o contact	
	FAILURE	-	c/o contact	
Contact material		Ag + Au-clad		
Minimum switching voltage / Minimum switching current		5 V DC / 1 mA		
Maximum switching voltage / Maximum switching current		50 V AC / 1.0 A, 30 V DC / 0.5 A		
Mechanical lifetime		5 x 10 ⁶ switching cycles		
Electrical lifetime		0.1 x 10 ⁶ switching cycles		
Maximum fuse rating to achieve short-circuit protection	n/o or n/c contact	1.0 A AC / 0.5 A DC		
General data				
Maximum internal power consumption		7 W	20 W	40 W
Power consumption with unloaded output		0.75 W	3 W	1.6 W
Energy storage (min.)		1000 Ws	10000 Ws	8000 Ws
Typical charging time at load current	100 %	65 s	134 s	135 s
	0 %	56 s	82 s	62 s
Typical buffering time at load current ¹⁾	100 %	13 s	38 s	15 s
	50 %	28 s	76 s	30 s
	25 %	66 s	140 s	60 s
	10 %	148 s	380 s	150 s
Efficiency		greater than 90 %		
Dimensions (W x H x D)	product dimensions	60 x 99 x 120 mm (2.36 x 3.90 x 4.72 in)	116 x 170 x 147 mm (4.57 x 6.69 x 5.79 in)	84 x 197 x 213 mm (3.31 x 7.76 x 8.39 in)
Weight	net weight	0.55 kg (1.21 lb)	2.1 kg (4.63 lb)	2.2 kg (4.85 lb)
Material	cover / housing shell	steel sheet powdered		
Mounting		DIN rail (IEC/EN 60715), snap-on mounting without any tool		
Mounting position		horizontal		
Minimum distance to other units	horizontal	not necessary		
	vertical	40 mm (1.58 in)		80 mm (3.15 in)
Pollution degree		2		
Degree of protection	housing / terminal	IP20		
Protection class (IEC/EN 61140)		III SELV / PELV (condition: power supply fulfills class III)		
Electrical connection - Input circuit / Output circuit		pull spring terminals	pull spring terminals	pluggable screw type terminals
Wire size	fine-strand with(out) wire end ferrule	0.08-1.0 mm ² (28-18 AWG)	0.08-1.5 mm ² (28-18 AWG)	0.2-4.0 mm ² (24-12 AWG)
	rigid	0.08-1.5 mm ² (28-16 AWG)	0.08-4.0 mm ² (28-16 AWG)	0.2-6.0 mm ² (24-10 AWG)

CP-B range

Technical data, Technical diagrams

Data at $T_a = 25\text{ °C}$ and rated values, unless otherwise indicated

Type	CP-B 24/3.0	CP-B 24/10.0	CP-B 24/20.0
Stripping length	6.0 mm (0.24 in)		7.0 mm (0.28 in)
Signalling circuit			
Wire size	fine-strand with(out) wire end ferrule		0.08-1.0 mm ² (28-18 AWG)
	rigid		0.08-1.5 mm ² (28-16 AWG)
Stripping length	6.0 mm (0.24 in)		7.0 mm (0.28 in)
Environmental data			
Ambient temperature	operation	-40...+60 °C	-20...+60 °C
	storage	-40...+60 °C	-20...+60 °C
Standards			
Product standard	EN 50178		
Low Voltage Directive	2006/95/EC		
EMC Directive	2004/108/EC		
RoHS Directive	2002/95/EC		
Electrical safety	EN 50178, EN 60950, UL 508		
Electromagnetic compatibility			
Interference immunity to	IEC/EN 61000-6-1, IEC/EN 61000-6-2		
electrostatic discharge	IEC/EN 61000-4-2	Level 3, 6 kV / 8 kV	
radiated, radio-frequency, electromagnetic field	IEC/EN 61000-4-3	Level 3, 10 V/m (27-1000 MHz) / Level 2, 3 V/m (1400-2700 MHz)	
electrical fast transient/burst	IEC/EN 61000-4-4	Level 3, 2(1) kV / 5 kHz	
surge	IEC/EN 61000-4-5	Level 1, 0.5 kV	
conducted disturbances, induced by radio-frequency fields	IEC/EN 61000-4-6	Level 3, 10 V (150 kHz-80 MHz)	
voltage dips, short interruptions and voltage variations	IEC/EN 61000-4-11	buffered by ultra-capacitors	
Interference emission	EN 61000-6-3, EN 61000-6-4		
high-frequency radiated	DIN EN 55011	B/C1	
high-frequency conducted	DIN EN 55011	B/C1	

¹⁾ buffering time $\approx \frac{\text{energy storage} \times 0.9}{\text{load current} \times \text{output voltage}}$

„Approvals and marks“ on page 3/4.

Technical diagrams

Output curve at $T_u = 25\text{ °C}$

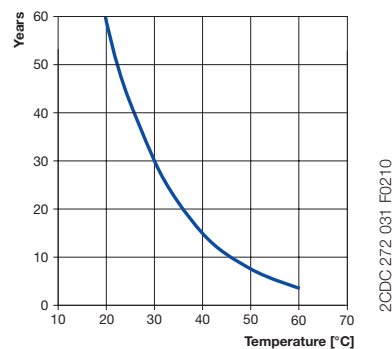
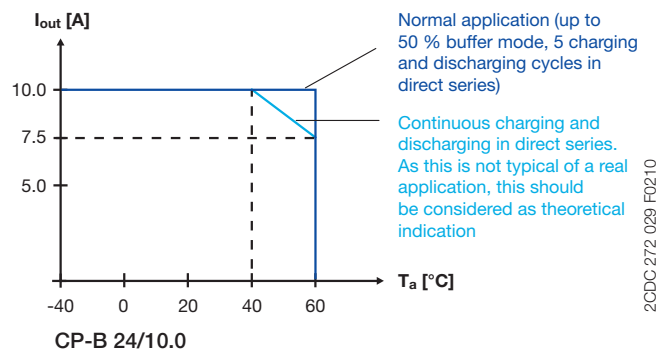
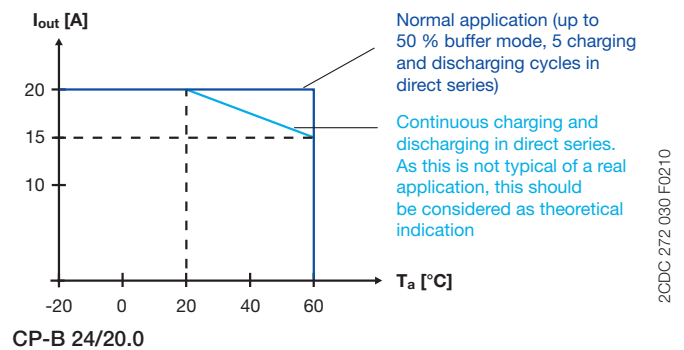
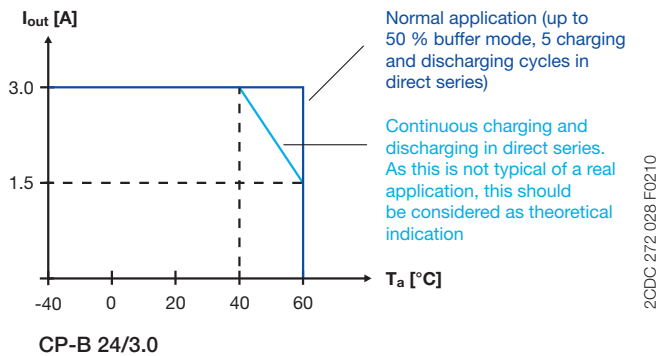

Characteristic curve of the temperature at rated load

Capacitor's life span over temperature

CP-B range Dimensional drawings

Dimensional drawings

dimensions in mm and inches

3

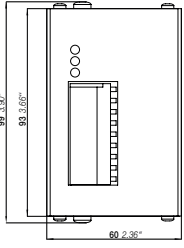

CP-B 24/3.0

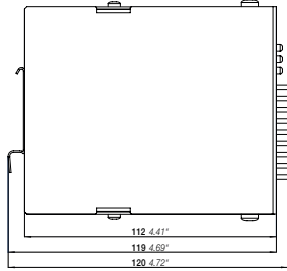

2CDC 272 037 F0010

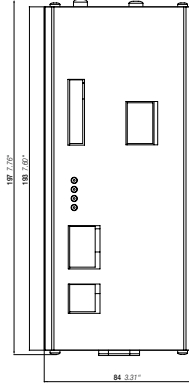

CP-B 24/20.0

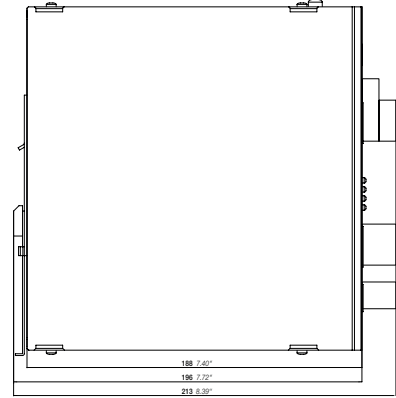

2CDC 272 039 F0010

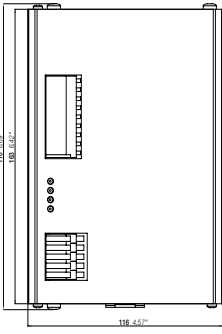

CP-B 24/10.0

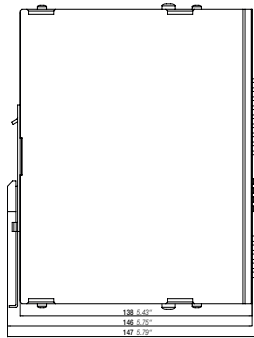

2CDC 272 038 F0010

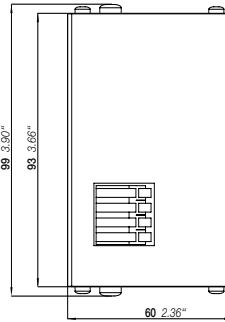

CP-B EXT.2

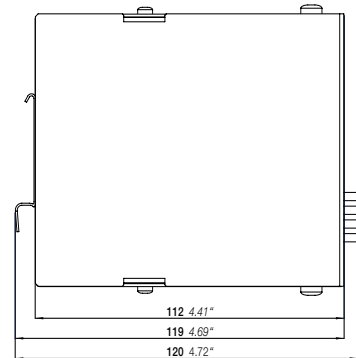

2CDC 272 036 F0010

CP-B range

Technical data

Data at $T_a = 25\text{ °C}$ and rated values, unless otherwise indicated

Type		CP-B EXT 2.0
Extension circuit		EXT+ EXT+ EXT- EXT-
Rated voltage		24 V DC
Voltage range		0-26.4 V DC
Rated current		3 A DC
Internal input fuse (apparatus protection, not accessible)		4 A slow acting (PTC)
Short-circuit protection		via internal 3 A fuse
Overload protection		only in combination with CP-B 24/3.0 or CP-B 24/20.0
Indication of operational states		status information and fault messages of the buffer module apply
General data		
Power consumption without load		0.5 W
Energy storage (min.)		2000 Ws
Dimensions (W x H x D)	product dimensions	60 x 99 x 120 mm (2.36 x 3.90 x 4.72 in)
	packaging dimensions	85 x 220 x 170 mm (3.35 x 8.66 x 6.69 in)
Weight	net weight	1.00 kg (0.20 lb)
Material	cover / housing shell	steel sheet powdered
Mounting		DIN rail (IEC/EN 60715), snap-on mounting without any tool
Mounting position		horizontal
Minimum distance to other units	horizontal	not necessary
	vertical	40 mm (1.58 in)
Pollution degree		2
Degree of protection	housing / terminal	IP20
Protection class (IEC/EN 61140)		III SELV / PELV (condition: power supply fulfills class III)
Electrical connection - Extension circuit		
Wire size	fine-strand with(out) wire end ferrule	0.08-1.0 mm ² (28-18 AWG)
	rigid	0.08-1.5 mm ² (28-16 AWG)
Stripping length		6.0 mm (0.24 in)
Signalling circuit		
Wire size	fine-strand with(out) wire end ferrule	0.08-1.0 mm ² (28-18 AWG)
	rigid	0.08-1.5 mm ² (28-16 AWG)
Stripping length		6.0 mm (0.24 in)
Environmental data		
Ambient temperature	operation	-40...+60 °C
	storage	-40...+60 °C
Vibration, sinusoidal	based on IEC/EN 60068-2-6	1.5 mm, 3-57.55 Hz; 2 g, 57.55-500 Hz, 10 cycles
Shock, half-sine	based on IEC/EN 60068-2-27	15 g, 11 ms, 3 axes, 6 faces, 3 times for each face
Standards		
Product standard		EN 50178
Low Voltage Directive		2006/95/EC
EMC Directive		2004/108/EC
RoHS Directive		2002/95/EC
Electrical safety		EN 50178, EN 60950, UL 508
Electromagnetic compatibility		
Interference immunity to		IEC/EN 61000-6-1, IEC/EN 61000-6-2
electrostatic discharge	IEC/EN 61000-4-2	Level 3, 6 kV / 8 kV
radiated, radio-frequency, electromagnetic field	IEC/EN 61000-4-3	Level 3, 10 V/m (27-1000 MHz) / Level 2, 3 V/m (1400-2700 MHz)
electrical fast transient/burst	IEC/EN 61000-4-4	Level 3, 2(1) kV / 5 kHz
surge	IEC/EN 61000-4-5	Level 1, 0.5 kV
conducted disturbances, induced by radio-frequency fields	IEC/EN 61000-4-6	Level 3, 10 V (150 kHz-80 MHz)
voltage dips, short interruptions and voltage variations	IEC/EN 61000-4-11	buffered by ultra-capacitors
Interference emission		EN 61000-6-3, EN 61000-6-4
high-frequency radiated	DIN EN 55011	B/C1
high-frequency conducted	DIN EN 55011	B/C1

„Approvals and marks“ on page 3/4.

Electronic protection devices EPD24

Product group picture

3

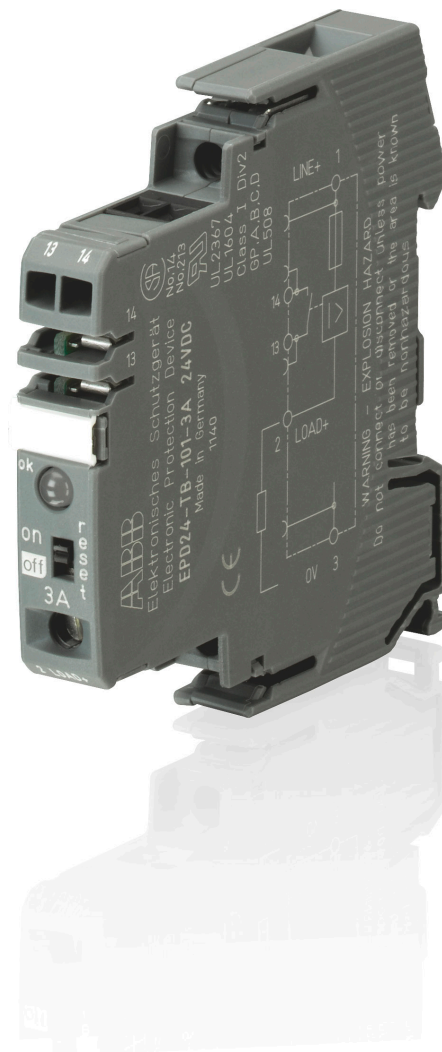

Electronic protection devices EPD24

Table of contents

Electronic protection devices EPD24	
Product group picture	3/73
Table of contents	3/74
Ordering details	3/75
Technical data	3/76
Technical information	3/78
Approvals, safety instructions	3/79
Installation guidelines	3/80

Electronic protection devices EPD24

Ordering details

3

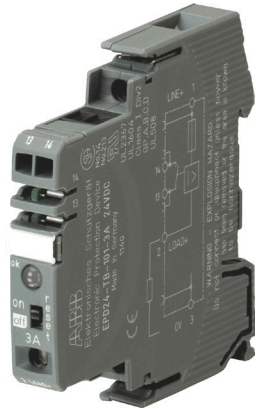

EPD24-TB-101-3A

2CDC 051 001 S0010

The protection devices EPD24 extend the ABB product range of Modular DIN rail components by electronic overcurrent protection modules for selective protection of 24V DC load circuits.

This protection is achieved by a combination of active electronic current limitation in the case of a short circuit and an overload deactivation from $1.1 \times I_n$ upwards.

If a fault occurs in a load circuit, the protection device EPD24 will detect this rapidly and reliably, disable the power output transistor and hence interrupt the current flow in the defective circuit. The maximum possible overcurrent is always limited to 1.3...1.8 times the selected rated current. An activation of capacitive loads up to 20,000 μF is possible, deactivation only occurring in the case of overloads or short circuits. Selective deactivation of the defective current circuit means undefined error states and a complete system stop are prevented.

Features

- Selective load protection, one electronic tripping characteristic.
- Active current limitation for safe connection of capacitive loads up to 20,000 μF and on overload/short circuit.
- Current ratings 0.5 A...12 A.
- Reliable overload disconnection with $1.1 \times I_n$
- Manual ON/OFF button
- Clear status and failure indication through LED and integrated auxiliary contact.
- Integral fail-safe element adjusted to current rating.
- Width per unit only 12.5 mm.
- Rail mounting
- Ease of wiring through busbar LINE+ and 0 V as well as signal bars.
- UL- and CSA-approvals allow international use of the devices.

Ordering details

Rated current I_n A	bbn 40 16779 EAN	Type	Order code	Price	Pkg qty	Weight (1 pce) kg (lb)
0.5	829960	EPD24-TB-101-0.5A	2CDE601101R2905		4	0.065 (1.433)
1	829984	EPD24-TB-101-1A	2CDE601101R2001		4	0.065 (1.433)
2	830003	EPD24-TB-101-2A	2CDE601101R2002		4	0.065 (1.433)
3	830027	EPD24-TB-101-3A	2CDE601101R2003		4	0.065 (1.433)
4	830041	EPD24-TB-101-4A	2CDE601101R2004		4	0.065 (1.433)
6	830065	EPD24-TB-101-6A	2CDE601101R2006		4	0.065 (1.433)
8	830089	EPD24-TB-101-8A	2CDE601101R2008		4	0.065 (1.433)
10	830102	EPD24-TB-101-10A	2CDE601101R2010		4	0.065 (1.433)
12	830126	EPD24-TB-101-12A	2CDE601101R2012		4	0.065 (1.433)

Ordering details

Description	bbn 40 16779 EAN	Type	Order code	Price	Pkg qty	Weight (1 pce) kg (lb)
Busbars for LINE+ and 0 V, grey insulation, length 500 mm ¹⁾	830140	EPD-BB500	2CDE605100R0500		10	0.2 (0.441)
Signal Bars for aux. contacts, grey insulation, length 21 mm	830164	EPD-SB21	2CDE605200R0021		10	0.4 (0.882)

¹⁾ Max. load with one line entry $I_{max} = 50 \text{ A}$ (recommended: mid line entry)
Max. load with two line entries $I_{max} = 63 \text{ A}$

Electronic protection devices EPD24

Technical data

Wiring diagramm

EPD24-TB-101

without signal input
with signal output F
(Single signal, N/O)

Operating condition: 13-14 closed
Fault condition: 13-14 open

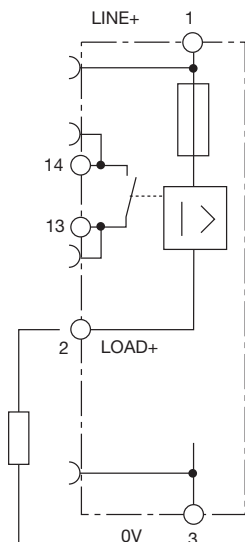

Operating data

Operating voltage U_B :	24 V DC (18...32 V)
Current rating I_N :	fixed current ratings: 0.5, 1, 2, 3, 4, 6, 8, 10, 12 A
Closed current I_V :	ON condition: typically 20...30 mA depending on signal output
Staus indication by means of:	<ul style="list-style-type: none"> - multicolour LED: <ul style="list-style-type: none"> Green: <ul style="list-style-type: none"> - unit is ON - load circuit / Power-MOSFET is switched on Orange: <ul style="list-style-type: none"> - in the event of overload or short circuit until electronic disconnection Red: <ul style="list-style-type: none"> - unit electronically disconnected - load circuit/Power-MOSFET OFF - undervoltage ($U_B < 8$ V) - after switch-on till the end of the delay period
	OFF: <ul style="list-style-type: none"> - manually switched off - or device is dead
	- potential-free auxiliary contact F
	- ON/OFF/ condition of switch

Load circuit

Load output	Power-MOSFET switching output (high slide switch)
Overload disconnection	typically $1.1 \times I_N$ ($1.05...1.35 \times I_N$)
Short-circuit current I_k	active current limitation
Trip time	see time/current characteristics
For electronic disconnection	typically 3 s at $I_{Load} > 1.1 \times I_N$ typically 100 ms...3 s at $I_{Load} > 1.8 \times I_N$ (or $1.5 \times I_N / 1.3 \times I_N$)
Temperature disconnection	internal temperature monitoring with electronic disconnection
Low voltage monitoring load output	with hysteresis, no reset required: load »OFF« at $U_B < 8$ V
Starting delay t_{start}	typically 0.5 sec after every switch-on and after applying U_B
Disconnection of load circuit	electronic disconnection
Free-wheeling circuit	suitable external free-wheeling circuit to be used with inductive load

Several load outputs must not be connected in parallel

Signal output

Electrical data	potential-free auxiliary contact max. 30 V DC/0.5 A, min. 10 V DC/10 mA
ON condition LED green	voltage U_B applied, switch is in ON position no overload, no short circuit
OFF condition LED off	- device switched off (switch is in OFF position) - no voltage U_B applied
Fault condition LED orange	overload condition $> 1.1 \times I_N$ up to electronic disconnection
Fault condition LED red	- electronic disconnection upon overload or short circuit - Device switched off with control signal (switch is in ON position)
Aux. contact	single signal, make contact
Fault	contact open, terminal 13-14 signal output fault conditions - no operating voltage U_B - ON/OFF switch is in OFF position - red LED lighted (electronic disconnection)

Electronic protection devices EPD24

Technical data

3

General data	
Fail-Safe element	backup fuse for EPD24 not required because of the integral redundant fail-safe element
Housing material	moulded
Mounting	symmetrical rail to EN 50022-35x7.5
Ambient temperature	0...+50 °C (without condensation, see EN 60204-1)
Storage temperature	-20...+70 °C
Humidity	96 hrs/95 % RH/40 °C to IEC 60068-2-78, test Cab. climate class 3K3 to EN 60721
Vibration	3 g, test to IEC 60068-2-6 test Fc
Degree of protection	housing: IP20 DIN 40050 terminals: IP20 DIN 40050
EMC	emission: EN 61000-6-3
(EMC directive, CE logo)	susceptibility: EN 61000-6-2
Isolations coordination (IEC 60934)	0.5 kV/pollution degree 2 reinforced insulation in operating area
Dielectric strength	max. 32 V DC (load circuit)
Isolation resistance (OFF condition)	n/a, only electronic disconnection
Approvals/Declarations of conformity	UL 2367 Solid State Overcurrent Protectors UL 1604, (class I, division 2, groups A, B, C, D) UL 508 CSA C22.2 No. 213 (class I, division 2) CSA C22.2 No. 142 CE logo
Dimensions (B x H x T)	12.5 x 80 x 83 mm
Weight	approx. 65 g
Terminals	Line+/LOAD+/0V
Screw terminals	M4
Max. cable cross section flexible with wire end ferrule w/wo plastic sleeve	0.5 – 10 mm ²
Multi-lead connection (2 identical cables) rigid/flexible	0.5 – 4 mm ²
Flexible with wire end ferrule without plastic sleeve	0.5 – 2.5 mm ²
Flexible with TWIN wire end ferrule with plastic sleeve	0.5 – 6 mm ²
Wire stripping length	10 mm
Tightening torque (EN 60934)	1.5 – 1.8 Nm
Terminals	aux. contacts
Screw terminals	M3
Max. cable cross section flexible with wire end ferrule w/wo plastic sleeve	0.25 - 2.5 mm ²
Wire stripping length	8 mm
Tightening torque (EN 60934)	0.5 Nm

Table 1: voltage drop, current limitation, max. load current

current rating I_N	typically voltage drop U_{ON} at I_N	active current limitation (typically)	max. load current at 100 % ON duty	
			$T_{ambient} = 40 °C$	$T_{ambient} = 40 °C$
0.5 A	70 mV	$1.8 \times I_N$	0.5 A	0.5 A
1 A	80 mV	$1.8 \times I_N$	1 A	1 A
2 A	130 mV	$1.8 \times I_N$	2 A	2 A
3 A	80 mV	$1.8 \times I_N$	3 A	3 A
4 A	100 mV	$1.8 \times I_N$	4 A	4 A
6 A	130 mV	$1.8 \times I_N$	6 A	5 A
8 A	120 mV	$1.5 \times I_N$	8 A	7 A
10 A	150 mV	$1.5 \times I_N$	10 A	9 A
12 A	180 mV	$1.3 \times I_N$	12 A	10.8 A

Attention: when mounted side-by-side without convection the ERD24 should not carry more than 80 % of its rated load with 100 % ON duty due to thermal effects.

Electronic protection devices EPD24

Technical information

Time/Current characteristic curve ($T_{\text{ambient}} = 25\text{ }^{\circ}\text{C}$)

- The trip time is typically 3 s in the range between $1.1 \times I_N$ and $1.8 \times I_N$ ¹⁾.
- Electronic current limitation occurs at typically $1.8 \times I_N$ ¹⁾ which means that under all overload conditions (independent of the power supply and the resistance of the load circuit) the max. overload before disconnection will not exceed $1.8 \times I_N$ times the current rating. Trip time is between 100 ms and 3 sec (depending on overload or at short circuit).
- Without this current limitation a considerably higher overload current would flow in the event of an overload or short circuit.

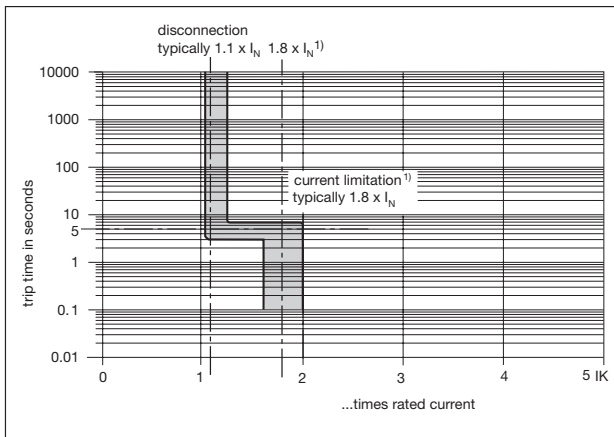

¹⁾ Current limitation typically $1.8 \times I_N$ at $I_N = 0.5\text{ A} \dots 6\text{ A}$
 Current limitation typically $1.5 \times I_N$ at $I_N = 8\text{ A}$ or 10 A
 Current limitation typically $1.3 \times I_N$ at $I_N = 12\text{ A}$

Maximum cable lengths

EPD24 reliably trips from $0\text{ }\Omega$ up to max. circuit resistance R_{max} .

Calculation of R_{max}

Selected rating I_N (A)	3	6
Operating voltage U_S (V DC) (= 80 % of 24 V) ²⁾	19.2	19.2
Trip current $I_{\text{ab}} = 1.25 \times I_N$ (A) (EPD24 trips after 3 s)	3.75	7.50
$R_{\text{max}} (\Omega) = (U_S / I_{\text{ab}}) - 0.050$	5.07	2.51

²⁾ Voltage drop of EPD24 and tolerance of trip point (typically $1.1 \times I_N = 1.05 \dots 1.35 \times I_N$) have been taken into account

Selection table for the incoming cable lengths with different cable cross-sections

Cable cross section A (mm ²)	0.14	0.25	0.34	0.5	0.75	1.00	1.50
Cable length L (m) (= single length)	cable resistance (Ω) = $(\rho_0 \times 2 \times L) / A$ ³⁾						
5	1.27	0.71	0.52	0.36	0.24	0.18	0.12
10	2.54	1.42	1.05	0.71	0.47	0.36	0.24
15	3.81	2.14	1.57	1.07	0.71	0.53	0.36
20	5.09	2.85	2.09	1.42	0.95	0.71	0.47
25	6.36	3.56	2.62	1.78	1.19	0.89	0.59
30	7.63	4.27	3.14	2.14	1.42	1.07	0.71
35	8.90	4.98	3.66	2.49	1.66	1.25	0.83
40	10.17	5.70	4.19	2.85	1.90	1.42	0.95
45	11.44	6.41	4.71	3.20	2.14	1.60	1.07
50	12.71	7.12	5.24	3.56	2.37	1.78	1.19
75	19.07	10.68	7.85	5.34	3.56	2.67	1.78
100	25.34	14.24	10.47	7.12	4.75	3.56	2.37
125	31.79	17.80	13.09	8.90	5.93	4.45	2.97
150	38.14	21.36	15.71	10.68	7.12	5.34	3.56
175	44.50	24.92	18.32	12.46	8.31	6.23	4.15
200	50.86	28.48	20.94	14.24	9.49	7.12	4.75
225	57.21	32.04	23.56	16.02	10.68	8.01	5.34
250	63.57	35.60	26.18	17.80	11.87	8.90	5.93

³⁾ Resistivity of copper $\rho_0 = 0.0178 (\Omega \times \text{mm}^2) / \text{m}$

Example 1: max. length for 1.5 mm² and 3 A: **214 m**

Example 2: max. length for 1.5 mm² and 6 A: **106 m**

Example 3: mixed wiring: (Control cabinet --- sensor/actuator level)

$R_1 = 40\text{ m}$ for 1.5 mm² and $R_2 = 5\text{ m}$ for 0.25 mm²:

$R_1 = 0.95\text{ }\Omega$, $R_2 = 0.71\text{ }\Omega$, **total ($R_1 + R_2$) = 1.66 Ω**

Electronic protection devices EPD24

Approvals, Safety instructions

Please note

The user must ensure that the cable cross sections of the relevant load circuit are suitable for the current rating of the EPD24 used. Automatic start-up of machinery after shut down must be prevented (Machinery Directive 98/37/EG and EN 60204-1). In the event of a short circuit or overload the load circuit will be disconnected electronically by the EPD24.

Information on UL approvals/CSA approvals

3



UL1604
UL File # E 339238



CSA C22.2 No. 213 (Class I, Division 2)
CSA File # 2305929

Operating Temperature Code T5

- This equipment is suitable for use in Class I, Division 2, Groups A, B, C and D or non-hazardous locations only

WARNING:

- Exposure to some chemicals may degrade the sealing properties of materials used in the following device: relay

Sealant Material:

Generic Name: Modified diglycidyl ether of bisphenol A

Supplier: Fine Polymers Corporation

Type: Epi Fine 4616L-160PK

Casing Material:

Generic Name: Liquid Crystal Polymer

Supplier: Sumitomo Chemical

Type: E4008, E4009, or E6008

RECOMMENDATION:

- Periodically inspect the device named above for any degradation of properties and replace if degradation is found

WARNING – EXPLOSION HAZARD:

- Do not disconnect equipment unless power has been removed or the area is known to be non-hazardous
- Substitution of any components may impair suitability for Class I, Division 2

UL2367



Non-hazardous use - UL File # E 339236

UL 508



Non-hazardous use - UL File # E 149922

CSA C22.2 No. 14



CSA C22.2 No. 142 - CSA File # E 2305929

Class 2

Meets requirement for Class 2 current limitation (EPD24 ... -0,5 A/1 A/2 A/3 A)

Electronic protection devices EPD24

Installation guidelines

The EPD24 features an integral power distribution system.

The following wiring modes are possible with various pluggable current and signal busbars:

- LINE+ (24 V DC)
- 0 V
- **Caution:** The electronic devices EPD24 require a 0 V connection
- Auxiliary contacts

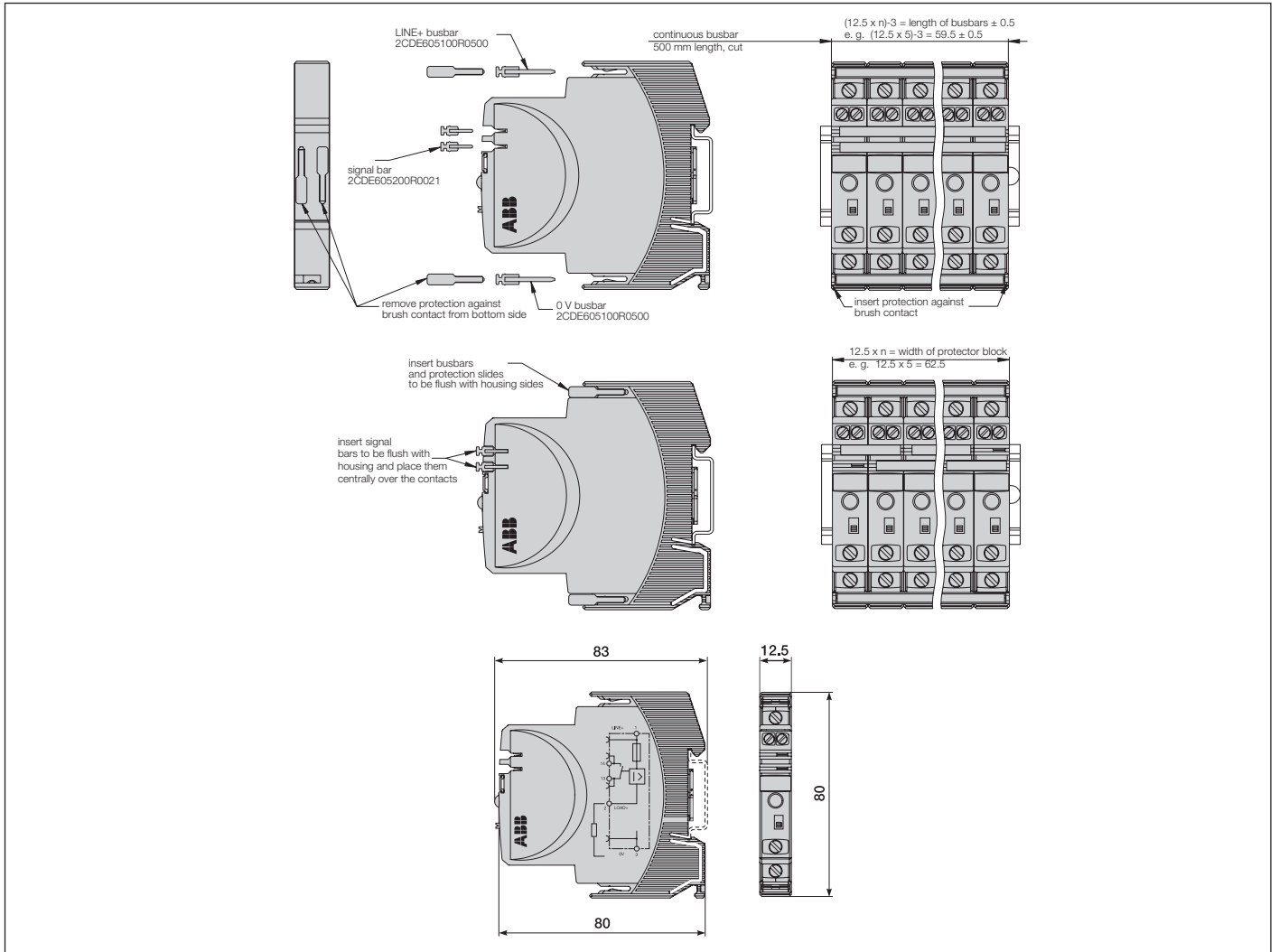

Mounting procedure

Before wiring insert busbars into protector block. A maximum of 10 connection cycles are permissible using connecting busbars.

Recommendation

After 10 units the busbars should be interrupted and receive a new entry live.

Table of length for busbars

(Order code 2CDE605100R0500)

No. of units	2	3	4	5	6	7	8	9	10
Length of busbar (mm) ± 0.5 mm	22	34.5	47	59.5	72	84.5	97	109.5	122

Analog signal converters, Serial data converters

Product group picture

4



Analog signal converters, Serial data converters

Table of contents

Analog signal converters, serial data converters	
Table of contents	4/2
Overview	4/3
Overview	4/4
Analog signal converters - CC-E range	4/5
Table of contents	4/6
Benefits and advantages	4/7
Ordering details - Standard signal converters	4/8
Ordering details - RTD converters	4/9
Ordering details - Thermocouple converters	4/10
Ordering details - Measuring converters	4/11
DIP switch settings and dimensional drawings	4/12
Wiring instructions	4/13
Technical data	4/14
Analog signal converters - CC-U range	4/17
Table of contents	4/18
Overview	4/19
Ordering details	4/21
Ordering details - Accessories	4/22
DIP switch settings	4/23
Wiring instructions	4/25
Technical information	4/26
Technical data	4/29
Technical diag., Connection diag., Dimensional drawings	4/32
Serial data converters	4/33
Table of contents	4/34
Benefits and advantages	4/35
Selection table	4/36
Ordering details	4/37
Connection diagrams and jumper settings	4/38
Technical data	4/45
Dimensional drawings	4/55

Analog signal converters, Serial data converters

Overview

Applications for analog signal processing and correct solution using CC-E and CC-U converters

Nearly every process includes a control system that receives data by means of analog signals and then evaluates the data and sets the respective parameters correspondingly.

When transmitting analog signals numerous problems may arise which can disturb or even block an ideal behavior of the process.

4

Below we have listed some processing problems together with the respective solutions to solve these problems:

Signal conversion

Sometimes the available signals cannot be processed by the controller or the actuator. In this case, signal converters are required to convert the input signal (or different input signals) to the desired output signal.

Signal amplification

If long lines or high burdens have to be operated, it may be necessary to amplify the signal. CC analog signal converters require only low input power and provide high output power.

Thus, there are no restrictions for the converter's position on the line, i.e. it can be used

- for signal refreshing ① at the end of the line (low input power)
- or for signal amplification ② at the beginning of the line (high output power).

Signal filtering

Particularly on long lines or in rough industrial environments the signals are exposed to high electromagnetic interferences. The frequency of the coupled interference signals may be in the range of the common mains frequency (50 Hz) or even much higher (in case of frequency converters). According to the specific requirements, analog signal converters are available which provide reliable suppression of those interferences by means of an input low-pass filter.

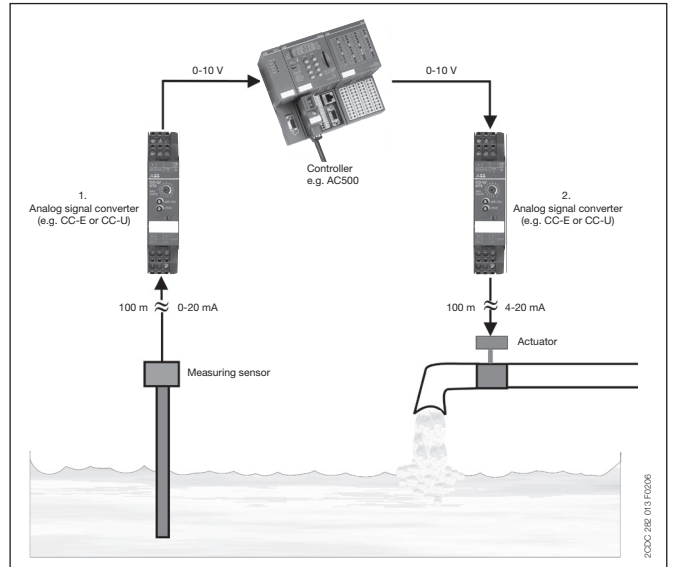

Signal separation

■ Protection against overvoltage

The increased use of micro-electronics make controls much more sensitive against overvoltages, resulting from lightning discharges or switching processes. Suppression diodes are incorporated in the input of the CC analog signal converters which enable the converters to arrest overvoltages with low energy level (resulting from switching processes) by themselves. The products furthermore provide electrical isolation between input, output and supply circuit for protection of the controller connected to the output.

■ Protection against ground loops

If components are used which refer to ground, the measuring signals can be falsified by a so-called ground loop. In this case, certain parts of the signal are transmitted via earth and not via the analog transmission line, thus causing incorrect evaluation of the signal. The electrical isolation between the input and the output disconnects these ground loops and thus enables correct signal transmission.

- existing
- ▲ existing for some devices
- pending

		CC-E/STD	CC-E/I	CC-U/STD	CC-U/STDR	CC-E/RTD	CC-U/RTD	CC-U/RTDR	CC-E/TC	CC-U/TC	CC-U/TCR	CC-E/I	CC-E _{Ac} /ILPO	CC-U/I	CC-U/V
Approvals															
	UL 508, CAN/CSA C22.2 No.14	■	■	■	■	■	■	■	■	■	■	■	■	■	■
	UL 1604 (Class I, Div 2, hazardous locations), CAN/CSA C22.2 No.213	▲		■		▲	■		▲	■		▲		■	■
	CB scheme				■			■			■				
	CCC				■			■			■				
Marks															
	CE	■	■	■	■	■	■	■	■	■	■	■	■	■	■
	C-Tick	■	■	■	■	■	■	■	■	■	■	■	■	■	■

Analog signal converters, Serial data converters

Overview

In the field of industrial data transmission, various processes of data transmission and interfaces are used today. Already existing systems need to be updated or connected to new devices for continuity of process. When new communication functions are not build-in, ABB propose a range of converters to be able to use from the standard RS232 or RS485, to the Ethernet open products or the Optical Fiber.

Ethernet communication is now one of the main features need in open communication, ABB propose the e-ILPH to connect the serial devices to the web world.

Uses

Adaptation

The use of converters allows the connection of two devices using different interfaces. To add new equipment to existing installations.

Electrical Isolation

To protect sensitive equipment it is sometimes necessary to use converters which allow electrical isolation.

To cross a disturbed environment

Some interfaces are more sensitive to noise. Electrically, it is preferable, in some cases, to change the interface or support.

Type of connection	Immunity to noise
RS232	Low
RS422	High
RS485	High
CL	High
OF	Very high
Ethernet	High

Multipoint connections

Some equipments are only designed to communicate in RS232 point to point connection. To communicate with several devices it is then necessary to use converters RS232 to RS422, RS485, CL or OF to reach multipoint mode.

Type of connection	Connection
RS232	Point to point
RS422	12 points
RS485	32 points
CL	5-6 points
OF	32 points
Ethernet	Point to point or multipoint

Increase in the transmission and amplification distances of the signals

Every connection has its own limits, to increase the communication distances you only have to change the type of link (converter) or amplify the signal (Repeater) using an ILPH.

Type of connection	Max. distances *
RS232	15m
RS422	1.2km
RS485	1.2km
CL	300-500m
OF	4km
Ethernet	100 m with CAT5 cable

* Depending on transmission speed.

"World Wide" communication

Communication is more and more used with Ethernet support. The interests are to have a distant access, to use an already existing network and to upload information and data on a supervisor or a computer. The conversions from serial to Ethernet protocol are used to connect local network to Ethernet.

Protocol conversion

Modbus is one of the main protocols used in the industrial networks. The creation of Modbus/TCP allows an adapted access to the Ethernet network. So, the conversion between these 2 protocols is necessary.

Example :

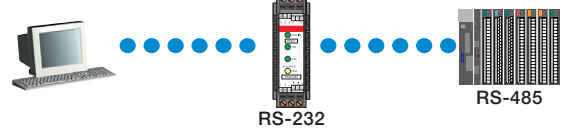

Example :

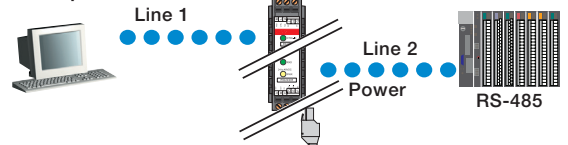

Example :

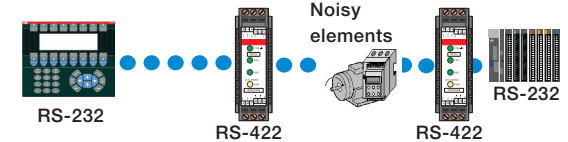

Example :

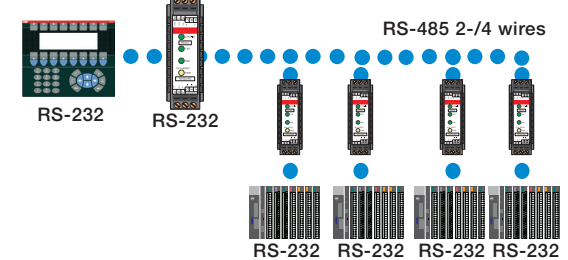

Example :

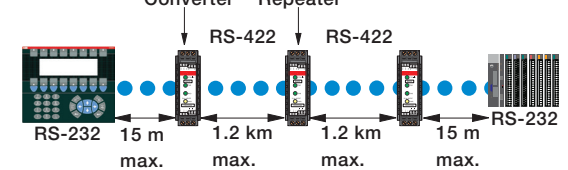

Example :

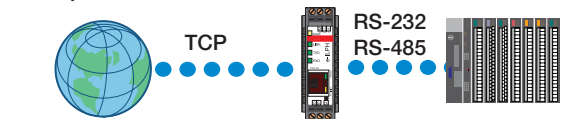

Example :

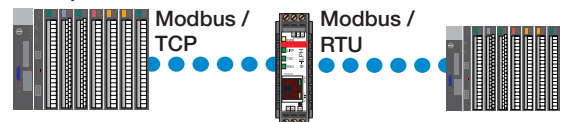

Analog signal converters - CC-E range

Product group picture

4



Analog signal converters - CC-E range

Table of contents

Analog signal converters - CC-E range	
Product group picture	4/5
Table of contents	4/6
Benefits and advantages	4/7
Ordering details - Standard signal converters	4/8
Ordering details - RTD converters	4/9
Ordering details - Thermocouple converters	4/10
Ordering details - Measuring converters	4/11
DIP switch settings and dimensional drawings	4/12
Wiring instructions	4/13
Technical data	4/14

Analog signal converters - CC-E range

Benefits and advantages

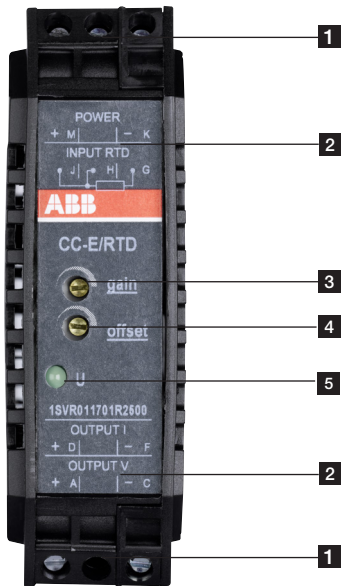

- 1 Terminals M, K, J, H, G
- 2 Terminal explanation
- 3 Adjustment of gain
- 4 Adjustment of offset
- 5 Indication of operational states
U - control supply voltage applied

CC-E range

- Universally configurable devices and single-function devices
- Adjustment and operating elements on the front side
- Safe operation by electrical 3-way isolation
- Unambiguous and clear connecting terminal markings

Conversion, measurement and separation of

- Standard signals (0-5 V, 0-10 V, 0-20 mA, 4-20 mA)
- Temperature signals of RTD sensors (PT 100)
- Thermocouple signals (types J and K)
- Current measurement signals (0-5 A, 0-20 A AC/DC)

Characteristics of single-function devices

- No adjustment or balancing necessary.

Characteristics of universal devices

- The required input and output ranges can be configured by means of directly accessible DIP switches positioned on the side
- Gain adjustment of $\pm 5\%$ by means of an adjustment potentiometer on the front-side
- Offset adjustment of $\pm 5\%$ by means of adjustment potentiometers on the front-side

CC-E/STD analog signal converter with 3-way electrical isolation

- 2 universally configurable devices (type CC-E/STD)
- 2x10 single-function devices
- "Plug and Work", no adjustment of single-function devices required

CC-E/TC analog signal converter for thermocouple signals of the types J and K with 3-way electrical isolation

- 2 universally configurable devices (type CC-E/TC)
- 2x6 single-function devices
- "Plug and Work", no adjustment of single-function devices required
- Integrated cold-junction compensation

CC-E I_{AC}/ILPO measuring converter without auxiliary power for sinusoidal currents 0-1 A, 0-5 A, output 4-20 mA

- Measuring converter for sinusoidal currents (0-1 A, 0-5 A)
- Measuring range selection by front-face sliding switch
- 4-20 mA output current in proportion to input current
- no additional power supply required

CC-E/RTD temperature signal converter for RTD sensors, linearized with 3-way electrical isolation

- 2 universally configurable devices (type CC-E/RTD)
- 2x12 single-function devices
- "Plug and Work", no adjustment of single-function devices required
- Temperature signal converter for PT100 sensors
- 2- or 3-wire connection

CC-E/I measuring converter for current signals 0-5 A, 0-20 A, AC/DC with 3-way electrical isolation

- 2 universally configurable devices (type CC-E/I)
- 2x6 single-function devices
- "Plug and Work", no adjustment of single-function devices required

Loop-powered current/current isolator without external power supply for analog current signals of 0-20 mA and 4-20 mA

- Electrical isolation between input and output
- Very low internal voltage drop ≤ 2.5 V
- Available with one or two independent channels
- Width only 18 mm (1 and 2 channels)

Analog signal converters - CC-E range

Ordering details - Standard signal converters



CC-E/I

2CDC 281 010 F0003



CC-E V/V

2CDC 281 001 F0003



CC-E I/I-2

2CDC 281 041 F0003

Ordering details - Standard signal converters

Supply voltage range	Input signal	Output signal	Type	Order code	Price 1 pce	Weight (1 pce) kg (lb)	
24 V DC	0-5 V, 0-10 V 0-20 mA, 4-20 mA	0-5 V, 0-10 V 0-20 mA, 4-20 mA	CC-E/STD ¹⁾ 3)	1SVR011700R0000		0.088 (0.194)	
		0-10 V	CC-E V/V	1SVR011710R2100		0.083 (0.183)	
	0-10 V	0-20 mA	CC-E V/I	1SVR011711R1600		0.084 (0.185)	
		4-20 mA	CC-E V/I	1SVR011712R1700		0.084 (0.187)	
	0-20 mA	0-10 V	CC-E I/V	1SVR011713R1000		0.082 (0.181)	
		0-20 mA	CC-E I/I	1SVR011714R1100		0.084 (0.187)	
		4-20 mA	CC-E I/I	1SVR011715R1200		0.084 (0.185)	
		4-20 mA	0-10 V	CC-E I/V	1SVR011716R1300		0.084 (0.185)
	4-20 mA	0-20 mA	CC-E I/I	1SVR011717R1400		0.084 (0.187)	
		4-20 mA	CC-E I/I	1SVR011718R2500		0.084 (0.187)	
	-10...+10 V	-10...+10 V	CC-E V/V	1SVR011719R2600		0.082 (0.181)	
	110-240 V AC	0-5 V, 0-10 V 0-20 mA, 4-20 mA	0-5 V, 0-10 V 0-20 mA, 4-20 mA	CC-E/STD ³⁾	1SVR011705R2100		0.090 (0.198)
0-10 V			CC-E V/V	1SVR011720R2300		0.096 (0.212)	
0-10 V		0-20 mA	CC-E V/I	1SVR011721R1000		0.087 (0.192)	
		4-20 mA	CC-E V/I	1SVR011722R1100		0.091 (0.200)	
0-20 mA		0-10 V	CC-E V/V	1SVR011723R1200		0.091 (0.200)	
		0-20 mA	CC-E I/I	1SVR011724R1300		0.088 (0.194)	
4-20 mA		4-20 mA	CC-E I/I	1SVR011725R1400		0.088 (0.194)	
		0-10 V	CC-E V/V	1SVR011726R1500		0.096 (0.212)	
4-20 mA		0-20 mA	CC-E I/I	1SVR011727R1600		0.087 (0.192)	
		4-20 mA	CC-E I/I	1SVR011728R2700		0.088 (0.194)	
loop powered		-10...+10 V	-10...+10 V	CC-E V/V	1SVR011729R2000		0.086 (0.190)
		0-20 mA, 4-20 mA	0-20 mA, 4-20 mA	CC-E I/I-1 ²⁾	1SVR010200R1600		0.038 (0.084)
	CC-E I/I-2 ²⁾			1SVR010201R0300		0.044 (0.097)	

¹⁾ 1604 Class I, Div.2 (universal device)

²⁾ CC-E-I/I-1 has 1 channel, CC-E-I/I-1 has 2 channels

³⁾ 3-way electrical isolation

⁴⁾ with relay output

Analog signal converters - CC-E range

Ordering details - RTD converters



CC-E/RTD

2CDC281-004-F0003

4

Ordering details - RTD converters

Supply voltage range	Input signal	Output signal	Type	Order code	Price 1 pce	Weight (1 pce) kg (lb)	
24 V DC	refer to table	0-10 V, 0-20 mA, 4-20 mA	CC-E/RTD ¹⁾	1SVR011701R2500		0.091 (0.200)	
	PT100 0...100 °C	0-10 V	CC-E RTD/V	1SVR011730R2500		0.084 (0.185)	
		0-20 mA	CC-E RTD/I	1SVR011731R1200		0.086 (0.190)	
		4-20 mA	CC-E RTD/I	1SVR011732R1300			
		0-10 V	CC-E RTD/V	1SVR011733R1400		0.083 (0.183)	
	PT100 -50...+50 °C	0-20 mA	CC-E RTD/I	1SVR011734R1500		0.084 (0.185)	
		4-20 mA	CC-E RTD/I	1SVR011735R1600		0.084 (0.187)	
		0-10 V	CC-E RTD/V	1SVR011736R1700		0.084 (0.185)	
	PT100 0...300 °C	0-20 mA	CC-E RTD/I	1SVR011737R1000		0.084 (0.187)	
		4-20 mA	CC-E RTD/I	1SVR011738R2100		0.101	
		0-10 V	CC-E RTD/V	1SVR011739R2200		0.084 (0.185)	
		PT100 -50...+250 °C	0-20 mA	CC-E RTD/I	1SVR011740R0700		0.084 (0.187)
	4-20 mA		CC-E RTD/I	1SVR011741R2400			
	110-240 V AC	refer to table	0-10 V, 0-20 mA, 4-20 mA	CC-E/RTD	1SVR011706R2200		0.093 (0.205)
		PT100 0...100 °C	0-10 V	CC-E RTD/V	1SVR011788R2400		0.086 (0.190)
			0-20 mA	CC-E RTD/I	1SVR011789R2500		0.088 (0.194)
			4-20 mA	CC-E RTD/I	1SVR011790R2200		0.089 (0.196)
		PT100 -50...+50 °C	0-10 V	CC-E RTD/V	1SVR011791R1700		0.087 (0.192)
0-20 mA			CC-E RTD/I	1SVR011792R1000		0.089 (0.196)	
4-20 mA			CC-E RTD/I	1SVR011793R1100			
PT100 0...300 °C		0-10 V	CC-E RTD/V	1SVR011794R1200		0.087 (0.192)	
		0-20 mA	CC-E RTD/I	1SVR011795R1300		0.089 (0.196)	
		4-20 mA	CC-E RTD/I	1SVR011796R1400			
PT100 -50...+250 °C		0-10 V	CC-E RTD/V	1SVR011797R1500		0.086 (0.190)	
		0-20 mA	CC-E RTD/I	1SVR011798R2600		0.089 (0.196)	
	4-20 mA	CC-E RTD/I	1SVR011799R2700		0.088 (0.194)		

¹⁾ 1604 Class I, Div.2 (universal device)

²⁾ CC-E-I/I-1 has 1 channel, CC-E-I/I-1 has 2 channels

⁴⁾ with relay output

Analog signal converters - CC-E range

Ordering details - Thermocouple converters



CC-E TC

2CDC 281 007 F0003

Ordering details - Thermocouple Converters

Supply voltage range	Input signal	Output signal	Type	Order code	Price 1 pce	Weight (1 pce) kg (lb)	
24 V DC	thermocouple types J and K	0-10 V, 0-20 mA, 4-20 mA	CC-E/TC ⁴⁾	1SVR011702R2600		0.089 (0.196)	
		0-10 V	CC-E TC/V	1SVR011750R0100		0.087 (0.192)	
	type J 0...600 °C	0-20 mA	CC-E TC/I	1SVR011751R2600		0.084 (0.187)	
		4-20 mA	CC-E TC/I	1SVR011752R2700		0.102	
	type K 0...1000 °C	0-10 V	CC-E TC/V	1SVR011753R2000		0.084 (0.185)	
		0-20 mA	CC-E TC/I	1SVR011754R2100		0.086 (0.190)	
		4-20 mA	CC-E TC/I	1SVR011755R2200		0.088 (0.194)	
		0-10 V, 0-20 mA, 4-20 mA	CC-E/TC	1SVR011707R2300		0.084 (0.187)	
	110-240 V AC	thermocouple types J and K	0-10 V	CC-E TC/V	1SVR011760R0300		0.088 (0.194)
			0-20 mA	CC-E TC/I	1SVR011761R2000		0.1 (0.220)
type J 0...600 °C		4-20 mA	CC-E TC/I	1SVR011762R2100		0.086 (0.190)	
		0-10 V	CC-E TC/V	1SVR011763R2200		0.088 (0.194)	
type K 0...1000 °C		0-20 mA	CC-E TC/I	1SVR011764R2300		0.086 (0.190)	
		4-20 mA	CC-E TC/I	1SVR011765R2400		0.088 (0.194)	

⁴⁾ with relay output

Analog signal converters - CC-E range

Ordering details - Measuring converters



CC-E I_{Ac}/ILPO

2CDC 281 018 F0004

4

Ordering details - Measuring Converters

Supply voltage range	Input signal	Output signal	Type	Order code	Price 1 pce	Weight (1 pce) kg (lb)
24 V DC	0-5 A, 0-20 A, AC/DC	0-10 V, 0-20 mA, 4-20 mA	CC-E/I ⁽⁵⁾	1SVR011703R2700		0.096 (0.212)
		0-10 V	CC-E I _{Ac} /V ⁽⁵⁾	1SVR011770R0500		0.090 (0.198)
	0-5 A, 0-20 A, AC	0-20 mA	CC-E I _{Ac} /I ⁽⁵⁾	1SVR011771R2200		0.092 (0.203)
		4-20 mA	CC-E I _{Ac} /I ⁽⁵⁾	1SVR011772R2300		0.092 (0.207)
	0-5 A, 0-20 A, DC	0-10 V	CC-E I _{Dc} /V ⁽⁵⁾	1SVR011773R2400		0.092 (0.207)
		0-20 mA	CC-E I _{Dc} /I ⁽⁵⁾	1SVR011774R2500		0.091 (0.200)
110-240 V AC	0-5 A, 0-20 A, AC/DC	0-10 V, 0-20 mA, 4-20 mA	CC-E/I ⁽⁵⁾	1SVR011708R0400		0.099 (0.218)
		0-10 V	CC-E I _{Ac} /V ⁽⁵⁾	1SVR011780R1100		0.092 (0.203)
	0-5 A, 0-20 A, AC	0-20 mA	CC-E I _{Ac} /I ⁽⁵⁾	1SVR011781R0600		0.092 (0.207)
		4-20 mA	CC-E I _{Ac} /I ⁽⁵⁾	1SVR011782R0700		0.095 (0.209)
	0-5 A, 0-20 A, DC	0-10 V	CC-E I _{Dc} /V ⁽⁵⁾	1SVR011783R0000		0.093 (0.205)
		0-20 mA	CC-E I _{Dc} /I ⁽⁵⁾	1SVR011784R0100		0.095 (0.209)
loop powered	0-1 A, 0-5 A, AC	4-20 mA	CC-E I _{Ac} /ILPO ⁽⁶⁾	1SVR010203R0500		0.052 (0.115)

⁽⁵⁾ with relay output

⁽⁶⁾ for sinusoidal currents

Analog signal converters - CC-E range

DIP switch settings, Dimensional drawings

CC-E/STD, CC-E x/x (universal devices)

Input	Output	Switch							
		1	2	3	4	5	6	7	8
0...5 V	0...5 V			■	■	■	■	■	■
	0...10 V			■	■	■	■	■	■
	0...20 mA			■	■	■	■	■	■
	4...20 mA			■	■	■	■	■	■
0...10 V	0...5 V			■	■	■	■	■	■
	0...10 V			■	■	■	■	■	■
	0...20 mA			■	■	■	■	■	■
	4...20 mA			■	■	■	■	■	■
0...20 mA	0...5 V	■							
	0...10 V	■							
	0...20 mA	■							
	4...20 mA	■							
4...20 mA	0...5 V	■	■						
	0...10 V	■	■						
	0...20 mA	■	■						
	4...20 mA	■	■						

2CDC 282 001 F0204

Legend	
■	ON
□	OFF

2CDC 282 002 F0204

CC-E/RTD

Input	Output	Switch					
		1	2	3	4	5	6
0...100 °C	0...10 V				■	■	■
	0-20 mA				■	■	■
	4-20 mA				■	■	■
0...300 °C	0-10 V				■	■	■
	0-20 mA				■	■	■
	4-20 mA				■	■	■
0...500 °C	0-10 V				■	■	■
	0-20 mA				■	■	■
	4-20 mA				■	■	■
-50...+50 °C	0-10 V	■					
	0-20 mA	■					
	4-20 mA	■					
-50...+250 °C	0-10 V	■	■				
	0-20 mA	■	■				
	4-20 mA	■	■				
-50...+450 °C	0-10 V	■	■				
	0-20 mA	■	■				
	4-20 mA	■	■				
High fail safe		■	■	■	■	■	■
Low fail safe		■	■	■	■	■	■

2CDC 282 006 F0208

Legend	
■	ON
□	OFF
□	no influence

2CDC 282 003 F0204

CC-E/TC

Input	Output	Switch					
		1	2	3	4	5	6
TC-J: 0...600 °C	0...10 V		■	■			■
	0...20 mA		■	■			■
	4...20 mA		■	■			■
TC-K: 0...1000 °C	0...10 V	■					■
	0...20 mA	■					■
	4...20 mA	■					■
High fail safe		■	■	■	■	■	■
Low fail safe		■	■	■	■	■	■

2CDC 282 007 F0208

Legend	
■	ON
□	OFF
□	no influence

2CDC 282 003 F0204

CC-E/I

Input	Output	Switch					
		1	2	3	4	5	6
I - DC	0...10 V	■					
		■					
I - AC	0...20 mA	■					
		■					
I - DC	4...20 mA	■	■				
		■	■				
I - AC	4...20 mA	■	■				
		■	■				

2CDC 282 005 F0208

Legend	
■	ON
□	OFF

2CDC 282 002 F0204

Input range selection - CC-E/I

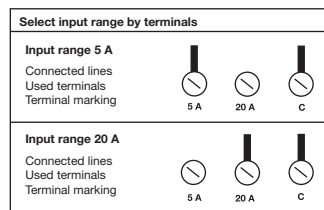

2CDC 282 011 F0204

Dimensional drawings

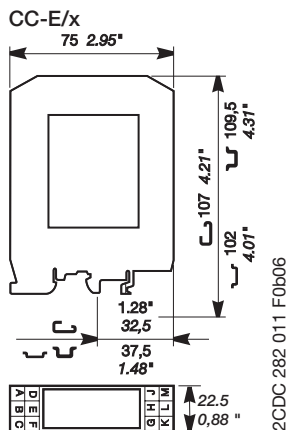

CC-E I_{AC}/ILPO, CC-E I/I

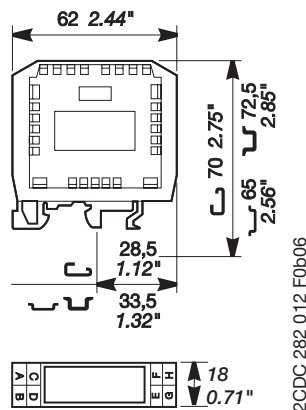

Analog signal converters - CC-E range

Wiring instructions

CC-E/STD, CC-E x/x (universal devices)

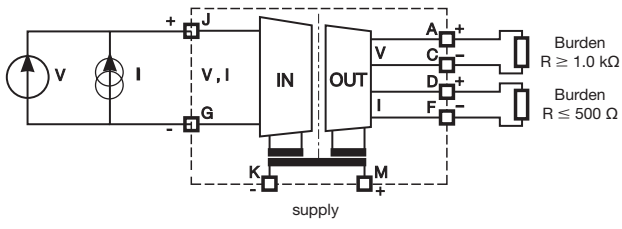

CC-E/RTD

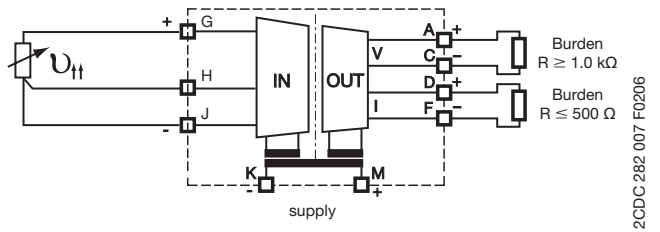

4

CC-E/TC and CC-E/I

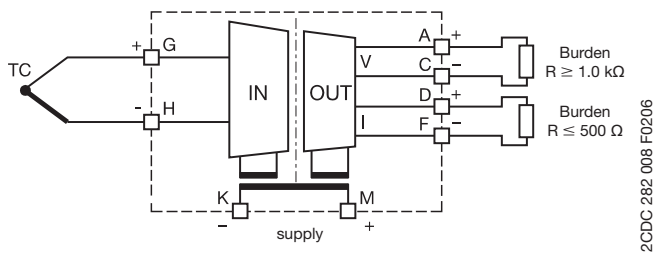

CC-E I_{AC}/ILPO

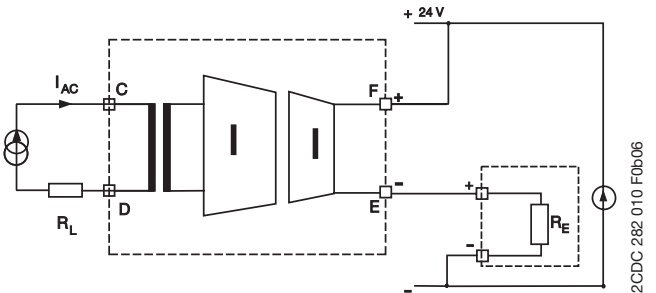

CC-E I/I-1

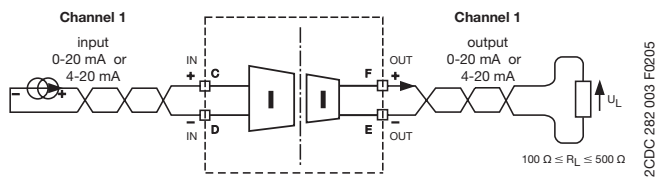

CC-E I/I-2

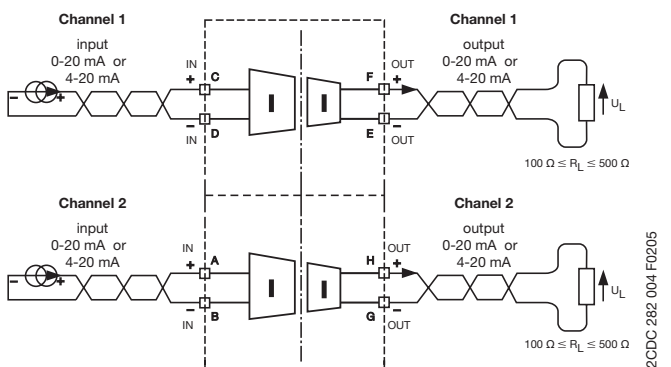

Analog signal converters - CC-E range

Technical data

Type	CC-E/STD / CC-E x/x		CC-E/RTD ³⁾	CC-E/TC	
Input circuits - Analog inputs	J-G-H	Current	Voltage	Temperature sensors	
Input signal		Standard signals		PT100	
Rated input range		0...20 mA / 4...20 mA	0...5 V / 0...10 V / -10...+10 V	-50...+500 °C	
Limitation of input signals		+55 mA	± 11 V		
Influence of line resistance				< 0.01 %/Ω	
Gain adjustment range		± 5 % (universal devices)			
Offset adjustment range		± 5 % (universal devices)			
Input impedance		50 Ω	1 MΩ	-	
Suppression at 50 Hz		-	-	> 35 dB	
Common-mode rejection		-		100 dB	
Output circuits - Analog outputs	D-F, A-C			Current	
Output signal		0-20 mA, 4-20 mA		Voltage	
Output burden		≤ 500 Ω		0-5 V, 0-10 V	
Accuracy ¹⁾		± 0.5 % of full-scale			
Residual ripple		< 0.5 %			
Response time		200 μs		10 ms	
Transmission frequency		2 kHz		80 Hz	
Reaction to input circuit interruption				2 Hz (up to -3 dB)	
				High fail safe: Output voltage > 115 % of measuring range ²⁾ Low fail safe: Output voltage < -0.6 V, output current = 0 mA	
Supply circuits	K-M	DC versions		AC versions	
Supply voltage		24 V DC		110-240 V AC - 50/60 Hz	
Supply voltage tolerance		-15...+15 %		-15...+10 %	
Power consumption		1.5 W typ.		1.5 VA typ.	
Indication of operational states		U: green LED			
General data		Ambient temperature range operation / storage			
		0...+60 °C / -20...+80 °C			
		Temperature coefficient			
		± 500 ppm/°C			
		Degree of protection (DIN 40050)			
		IP20			
		Mounting position			
		ventilation slots on top and bottom			
		Mounting			
		DIN rail (IEC/EN 60715), snap-on mounting			
Electrical connection		Wire size			
		rigid	0.2-4 mm ² (24-12 AWG)		
		fine-strand with(out) wire end ferrule	0.2-2.5 mm ² (24-14 AWG)		
		Stripping length			
		7 mm (0.28 inch)			
		Tightening torque			
		0.5 Nm (4.4 lb.in)			
Electromagnetic compatibility		Interference immunity			
		EN 61000-6-2			
		electrostatic discharge (ESD)	IEC/EN 61000-4-2	Level 3 (±6 kV / ±8 kV)	
		electromagnetic field (HF radiation resistance)	IEC/EN 61000-4-3	10 V/m	
		fast transients (Burst)	IEC/EN 61000-4-4	Level 3 (±2 kV / 5 kHz)	
		powerful impulses (Surge)	IEC/EN 61000-4-5	±2 kV / ±1 kV	
		HF line emission	IEC/EN 61000-4-6	10 V	
		Interference emission	EN 61000-6-4	Class B	
Isolation data		Test voltage between all isolated circuits			
		2.5 kV AC			
		Rated insulation voltage			
		-			

¹⁾ Includes non-linearity and factory setting, influenced by supply voltage and output load.

²⁾ Only -/RTD and -/TC: Single-function devices respond with Low fail safe to input signal interruptions.

³⁾ When connecting a 2-wire sensor, the terminals J and H have to be jumpered.

Approvals on page 4/4.

Analog signal converters - CC-E range

Technical data

4

Type	CC-E I/I-1 / CC-E I/I-2	
Input circuits - Analog inputs		
Current		
Input current I_{IN}	0-20 mA, 4-20 mA	
Min. input current	< 100 μ A	
Max. input current	50 mA ¹⁾ ($V_{IN} < 18$ V)	
Input voltage U_{IN}	< 2.5 V + ($I_{IN} \times R_i$)	
Input voltage drop U_i	< 2.5 V (20 mA, $R_i = 0 \Omega$)	
Max. input voltage	18 V ¹⁾ ($I_{IN} < 50$ mA)	
Output circuits		
Output current I_{OUT}	0-20 mA, 4-20 mA	
Output load R_L	0-500 Ω	
Output voltage U_{OUT}	$I_{OUT} \times R_L$	
Residual ripple	< 20 mV _{pp} (500 Ω , 20 mA)	
Response time (0-100 %)	< 15 ms (0-500 Ω , 20 mA), < 5 ms (500 Ω , 20 mA, 25 °C)	
Accuracy	≤ 0.1 % of full-scale (20 mA)	
Load influence (0-500 Ω)	$\leq \pm 0.05$ % / 100 Ω , ≤ -0.1 % / 100 Ω (25 °C)	
General data		
Width of the enclosure	18 mm	
Weight	1 channel	approx. 0.037 kg (0.082 (0.181) lb)
	2 channel	approx. 0.044 (0.097) kg (0.097 lb)
Mounting position	any	
Degree of protection	enclosure / terminals	IP20 / IP20
Ambient temperature range	operation / storage	-25...+60 °C / -40...+85 °C
Temperature coefficient	< ± 50 ppm / °C	
Mounting	DIN rail (IEC/EN 60715)	
Electrical connection		
Wire size	rigid	0.2-4 mm ² (24-12 AWG)
	fine-strand with(out) wire end ferrule	0.2-2.5 mm ² (24-14 AWG)
Stripping length	7 mm (0.28 inch)	
Tightening torque	0.5 Nm (4.4 lb.in)	
Standards		
Product standard	EN 50178	
Low Voltage Directive	2006/95/EC	
EMC Directive	2004/108/EC	
Electromagnetic compatibility		
Interference immunity	EN 61000-6-2	
electrostatic discharge (ESD)	EN 61000-4-2	Level 3 (± 6 kV / ± 8 kV)
electromagnetic field (HF radiation resistance)	EN 61000-4-3	10 V/m
fast transients (Burst)	EN 61000-4-4	Level 3 (± 2 kV / 5 kHz)
powerful impulses (Surge)	EN 61000-4-5	± 2 kV / ± 1 kV
HF line emission	EN 61000-4-6	10 V
magnetic fields	EN 61000-4-8	30 A/m
Interference emission	EN 61000-6-4	
Radiated noise	EN 55011	Class B
Operational reliability (EN 68-2-6)	4 g	
Mechanical resistance (EN 68-2-6)	10 g	
Environmental testing (IEC 68-2-30 Db)	24 h cycle, 55 °C, 93 % rel., 96 h	
Isolation data		
Insulation voltage input / output	500 V _{eff} / 50 Hz	
Insulation voltage between channels	5 kV _{eff} / 50 Hz (device with 2 channels)	
Pollution category	2	
Overvoltage category	II	

¹⁾ The input parameters have to be limited to the indicated maximum values.

Approvals on page 4/4.

Analog signal converters - CC-E range

Technical data

Type	CC-E/I J-G-H		CC-E I _{AC} /ILPO C-D
	AC current	DC current	2 meas. ranges selectable
Input circuits - Analog inputs			
Rated input range	0-5 A / 0-20 A	0-5 A / 0-20 A	0-1 A / 0-5 A / sinusoidal
Measuring frequency			50/60 Hz
Overload capacity of inputs	input range 1 input range 2	10 x I _{Nom} (50 A) for max. 1 s 10 x I _{Nom} (200 A) for max. 1 s	10 x I _{Nom} (50 A) for max. 2 s 10 x I _{Nom} (200 A) for max. 2 s
Gain adjustment range	±5 % (universal devices)		-
Offset adjustment range	±5 % (universal devices)		-
Input impedance / resistance	5A : 65 mΩ	20 A : 2.5 mΩ	5 mΩ
Output circuits - Analog outputs			
Output signal	0-20 mA / 4-20 mA	0-10 V	4-20 mA
Output burden / load	≤ 500 Ω	≥ 1.0 Ω	12 V DC: 150 Ω, 24 V DC: 750 Ω 30 V DC: 1050 Ω
Accuracy ¹⁾	± 2 % of full-scale		
Offset adjustment range	±5 % (universal device)		± 5 %
Gain adjustment range	±5 % (universal device)		± 20 %
Residual ripple	< 0.5 %		
Response time	0.5 s		0.6 s
Transmission frequency	DC or 50/60 Hz		AC: 50/60 Hz
Reaction to input circuit interruption	Low fail safe: output voltage < 200 mA, output current < 400 μA		-
Supply circuits			
	K-M	DC versions	AC versions
Supply voltage	24 V DC	110-240 V AC 50/60 Hz	12-30 V DC
Supply voltage tolerance	-15...+15 %	-15...+10 %	-
Power consumption	typ 1.5 W	typ 1.5 VA	-
Indication of operational states			
Supply voltage	U: green LED		-
General data			
Ambient temperature range operation / storage	0...+60 °C / -20...+80 °C		-20...+60 °C / -40...+80 °C
Temperature coefficient	± 500 ppm/°C		300 ppm/°C
Degree of protection (DIN 40050)	IP20		
Mounting position	ventilation slots on top and bottom		
Mounting	DIN rail (IEC/EN 60715), snap-on mounting		
Electrical connection			
Wire size	rigid	0.2-4 mm ² (24-12 AWG)	
	fine-strand with(out) wire end ferrule	0.2-2.5 mm ² (24-14 AWG)	
Stripping length	7 mm (0.28 inch)		
Tightening torque	0.5 Nm (4.4 lb.in)		
Electromagnetic compatibility			
Interference immunity	EN 61000-6-2		
electrostatic discharge (ESD)	IEC/EN 61000-4-2	Level 3 (±6 kV / ±8 kV)	
electromagnetic field (HF radiation resistance)	IEC/EN 61000-4-3	10 V/m	
fast transients (Burst)	IEC/EN 61000-4-4	Level 3 (±2 kV / 5 kH)	
powerful impulses (Surge)	IEC/EN 61000-4-5	±2 kV / ±1 kV	
HF line emission	IEC/EN 61000-4-6	10 V	
Interference emission	EN 61000-6-4	Class B	
Isolation data			
Test voltage (between all isolated circuits)	2.5 kV AC		
Rated insulation voltage	-		250 V AC

¹⁾ Includes non-linearity and factory setting, influenced by supply voltage and output load.

Approvals on page 4/4.

Analog signal converters - CC-U range

Product group picture



Analog signal converters - CC-U range

Table of contents

Analog signal converters - CC-U range	
Product group picture	4/17
Table of contents	4/18
Overview	4/19
Ordering details	4/21
Ordering details - Accessories	4/22
DIP switch settings	4/23
Wiring instructions	4/25
Technical information	4/26
Technical data	4/29
Technical diag., Connection diag., Dimensional drawings	4/32

Analog signal converters - CC-U range

Overview

CC-U range

- 8 different standard signal outputs on one device
- Input and output side universally configurable
- Also available with 2 threshold relay outputs
- Adjustment and operating elements on the front side
- Safe operation by electrical 3-way isolation
- Plug-in connecting terminals, unambiguously and clearly marked

Characteristics

- The required input and output ranges can be configured for all devices by means of directly accessible DIP switches positioned on the side.
- Due to the wide input range of the gain and offset stages all input signals between the minimum and the maximum input value can be universally converted to all common output signals.
- Devices for DC or AC (50/60 Hz) supply available.

Conversion, measurement and separation of

- Standard signals
- Signals of RTD sensors (PT10, PT100, PT1000)
- Thermocouple signals
- TRMS values of currents and voltages

4

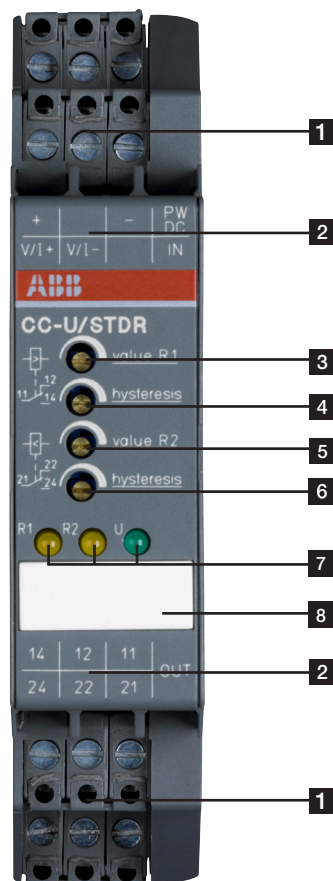

- 1 Terminals +, V/I+, V/I-, PW DC, IN, -
- 2 Terminal explanation
- 3 Adjustment of resistance value R1
- 4 Adjustment of hysteresis
- 5 Adjustment of resistance value R2
- 6 Adjustment of hysteresis
- 7 Indication of operational states
R1 yellow LED - resistance value R1
R2 yellow LED - resistance value R2
U green LED - supply voltage
- 8 Marker label

Analog signal converters - CC-U range

Overview

CC-U/STD universal signal converter with 3-way electrical isolation

- More than 120 configurations possible
- Configurable output signal response on input voltage signal interruption (low fail safe / high fail safe)
- Adjustment and operating elements on the front
- Short-circuit proof signal outputs
- Plug-in connecting terminals for inputs, outputs and supply
- Very fast signal transmission enables use in control systems

CC-U/RTD universal signal converter for PT10, PT100, PT1000 temperature sensors (acc. to IEC 751 and JIS C 16041), linearized with 3-way electrical isolation

- Configurable output signal response on input signal interruption (low / high fail safe)
- Adjustment and operating elements on the front-side
- Short-circuit proof signal outputs
- Plug-in connecting terminals for inputs, outputs and supply
- 2- or 3-wire connection

¹⁾ Japanese standard

CC-U/TC universal signal converter for thermocouples with 3-way electrical isolation

- Temperature signal converter for thermo-couples of the types K, J, T, S, E, N, R, B
- Continuously adjustable voltage signal input 0-10 mV and 0-50 mV
- Differential temperature meas. possible (see wiring instructions page 4/17)
- Configurable output signal response on input signal interruption (low fail safe / high fail safe)
- Adjustment and operating elements on the front-side
- Short-circuit proof signal outputs
- Plug-in connecting terminals for inputs, outputs and supply
- Cold-junction compensation selectable

CC-U/V universal measuring converter for RMS values of 0-600 V, with 3-way electrical isolation

- RMS converter for voltage signals up to 600 V of any wave form (DC, DC with superimposed AC components, pure sinusoidal, triangular, phase-angle controlled, etc. in a measuring range of 0-600 Hz)
- Adjustment and operating elements on the front
- Short-circuit proof signal outputs
- Plug-in connecting terminals for inputs, outputs and supply

CC-U/STDR universal signal converter for standard signals, with 2 threshold relay outputs and with 3-way electrical isolation

- Standard signal converter with 7 setting ranges
- 2 threshold relay outputs with one c/o contact each (threshold and respective hysteresis can be adjusted independently from each other)
- Open-circuit or closed-circuit principle configurable by means of a DIP switch
- 2 yellow LEDs for clear status indication of the output relays
- Plug-in connecting terminals for inputs, outputs and supply

CC-U/RTDR universal signal converter for temperature and resistance signals, with 2 threshold relay outputs and 3-way electrical isolation

- Temperature signal converter for PT100 signals (5 ranges up to 800 °C) and variable resistances from 0-380 Ω
- 2 threshold relay outputs with one c/o contact each (threshold and respective hysteresis can be adjusted independently from each other)
- Open-circuit or closed-circuit principle configurable by means of a DIP switch
- 2 yellow LEDs for clear status indication of the output relays
- Plug-in connecting terminals for inputs, outputs and supply
- 2- or 3-wire connection

CC-U/TCR universal signal converter for thermocouples, with 2 threshold relay outputs and 3-way electrical isolation

- Temperature signal converter for thermocouples of the types K, J, T, S
- 2 threshold relay outputs with one change-over contact each (threshold and respective hysteresis can be adjusted independently from each other)
- Open-circuit or closed-circuit principle configurable by means of a DIP switch
- 2 yellow LEDs for clear status indication of the output relays
- Plug-in connecting terminals for inputs, outputs and supply
- Integrated cold-junction compensation

CC-U/I universal measuring converter for RMS values of 0-1 A and 0-5 A, with 3-way electrical isolation

- RMS converter for current signals up to 1 A and up to 5 A of any wave form (DC, DC with superimposed AC components, pure sinusoidal, triangular, phase-angle controlled, etc. in a measuring range of 0-600 Hz)
- Adjustment and operating elements on the front
- Short-circuit proof signal outputs
- Plug-in connecting terminals for inputs, outputs and supply

Analog signal converters - CC-U range

Ordering details



2CDC 281 003 F0003

4 CC-U/STDR

Ordering details - Standard Signal Converters

Supply voltage range	Input signal	Output signal	Type	Order code	Price 1 pce	Weight (1 pce) kg (lb)
24-48 V DC, 24 V AC	refer to table	refer to table 2 c/o	CC-U/STD	1SVR040000R1700		0.125 (0.276)
110-240 V AC, 100-300 V DC				1SVR040001R0400		0.126 (0.278)
24-48 V DC, 24 V AC			CC-U/STDR ¹⁾	1SVR040010R0000		0.142 (0.313)
110-240 V AC, 100-300 V DC				1SVR040011R2500		



2CDC 281 005 F0003

CC-U/RTD

Ordering details - RTD Converters

Supply voltage range	Input signal	Output signal	Type	Order code	Price 1 pce	Weight (1 pce) kg (lb)
24-48 V DC, 24 V AC	refer to table	refer to table 2 c/o	CC-U/RTD	1SVR040002R0500		0.126 (0.278)
110-240 V AC, 100-300 V DC				1SVR040003R0600		0.128 (0.282)
24-48 V DC, 24 V AC			CC-U/RTDR ¹⁾	1SVR040012R2600		0.146 (0.322)
110-240 V AC, 100-300 V DC				1SVR040013R2700		0.148 (0.326)



2CDC 281 008 F0003

CC-U/TC

Ordering details - Thermocouple Converters

Supply voltage range	Input signal	Output signal	Type	Order code	Price 1 pce	Weight (1 pce) kg (lb)
24-48 V DC, 24 V AC	refer to table	refer to table 2 c/o	CC-U/TC	1SVR040004R0700		0.130 (0.287)
110-240 V AC, 100-300 V DC				1SVR040005R0000		0.128 (0.282)
24-48 V DC, 24 V AC			CC-U/TCR ¹⁾	1SVR040014R2000		0.145 (0.320)
110-240 V AC, 100-300 V DC				1SVR040015R2100		



2CDC 281 012 F0003

CC-U/I

Ordering details - Measuring Converters

Supply voltage range	Input signal	Output signal	Type	Order code	Price 1 pce	Weight (1 pce) kg (lb)
24-48 V DC, 24 V AC	refer to table	refer to table	CC-U/I ²⁾	1SVR040006R0100		0.128 (0.282)
110-240 V AC, 100-300 V DC				1SVR040007R0200		0.127 (0.280)
24-48 V DC, 24 V AC			CC-U/V ³⁾	1SVR040008R1300		0.128 (0.282)
110-240 V AC, 100-300 V DC				1SVR040009R1400		

¹⁾ with relay output

²⁾ for current RMS values

³⁾ for voltage RMS values

Analog signal converters - CC-U range

Ordering details - Accessories

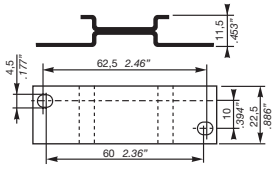

ADP.01

2CDC 252 187 F0005

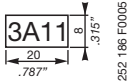

MAR.01

252 186 F0005

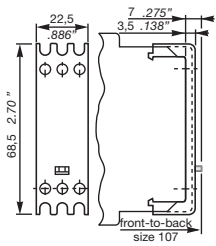

Sealable cover - COV.01

2CDC 252 185 F0005

Ordering details - Accessories

For type	Width in mm	Type	Order code	Price	Pkg qty	Weight (1 pce) g (oz)
CC-U	22.5	ADP.01	1SVR430029R0100		1	18.4 (0.65)
CC-U		MAR.01	1SVR366017R0100		10	0.19 (0.007)
CC-U	22.5	COV.01	1SVR430005R0100		1	5.2 (0.18)

Analog signal converters - CC-U range

DIP switch settings

CC-U/STD

Input	Switch 1								Gain	Coarse Type
	1	2	3	4	5	6	7	8		
Potentiometer									0	0
0...50 mV									A...D	C
0...100 mV									4...5	5
0...250 mV									0...1	1
0...500 mV									7...9	8
0...1 V									3...4	3
0...2.5 V									0	0
0...5 V									5...7	6
0...10 V									2	2
1...5 V									7...9	8
2...10 V									2...4	3
-10...+10 V									0	0
0...125 mV									3...4	3
0...8 V									3...4	3
-22.5...+22.5 mV									B...F	D
-11...+11 V									0	0
2.5...7.5 V									5...7	6
3.33...9.99 V									3...4	4
10...0 V									2	2
100...0 mV									4...5	5
0...1 mA									A...D	B
0...20 mA									2...4	3
4...20 mA									4...5	4
10...50 mA									0...1	1
20...4 mA									4...5	4
20...0 mA									4...2	3
-0.45...+0.45 mA									B...F	D
-55...+55 mA									4...6	5
High fail safe *)									-	-
Low fail safe *)									-	-
No fail safe *)									-	-

2CDC 282 019 F0203

*) Detection of input voltage signal interruptions:
If the input signal circuit is interrupted, the output signal changes to the adjusted minimum value (low fail safe) or maximum value (high fail safe).
If "No fail safe" is configured, input signal interruptions are not detected.

Output	Switch 2					
	1	2	3	4	5	6
0...5 V						
0...10 V						
1...5 V						
2...10 V						
-10...+10 V						
-5...+5 V						
-10...0 V						
-5...0 V						
0...6.66 V						
-10...+3.33 V						
-5...+1.66 V						
0...8 V						
0...4 V						
-10...-2 V						
-5...-1 V						
1.25...6.25 V						
-7.5...+2.5 V						
-3.75...+1.25 V						
1.66...8.33 V						
-6.66...+6.66 V						
-3.33...+3.33 V						
-8...0 V						
-4...0 V						
0...1 mA						
0...20 mA						
4...20 mA						
0...10 mA						
0...0.5 mA						
0...13.33 mA						
0...666 μA						
0...16 mA						
0...800 μA						
0...8 mA						
0...400 μA						
2.5...12.5 mA						
125...625 μA						
3.33...16.66 mA						
166...833 μA						
0.2...1 mA						
2...10 mA						
100...500 μA						

2CDC 282 020 F0203

Legend	
ON	■
OFF	□
no influence	■

2CDC 282 003 F0204

CC-U/STDR with relay output

Input	Switch					
	1	2	3	4	5	6
0...0 V						
0...5 V						
0...1 V						
-10...+10 V						
1...5 V						
0...20 mA						
4...20 mA						
Output						
Closed-circuit principle						
Open-circuit principle						

2CDC 282 005 F0204

Legend	
ON	■
OFF	□
no influence	■

2CDC 282 003 F0204

CC-U/RTD

Type	Input Range	Switch 1						Switch 2						Gain Coarse	
		1	2	3	4	5	6	1	2	3	4	5	6		
PT10	0...500 °C														F
	0...550 °C														E
	0...600 °C														D
	0...650 °C														C
	0...700 °C														B
	0...750 °C														A
PT100	0...800 °C														9
	0...850 °C														8
	0...50 °C														F
	0...60 °C														E
	0...70 °C														B
	0...80 °C														A
PT1000	0...90 °C														9
	0...100 °C														8
	0...200 °C														3
	0...300 °C														2
	0...400 °C														1
	0...500 °C														0
Low fail safe *)															-
High fail safe *)															-

*) Detection of input signal interruptions:
If the input signal circuit is interrupted, the output signal changes to the adjusted minimum value (low fail safe) or maximum value (high fail safe).

2CDC 282 023 F0203

CC-U/RTDR with relay output

Input PT100	Switch					
	1	2	3	4	5	6
0...100 °C						
0...200 °C						
0...400 °C						
0...600 °C						
0...800 °C						
Output						
Closed-circuit principle						
Open-circuit principle						

2CDC 282 007 F0204

Legend	
ON	■
OFF	□
no influence	■

2CDC 282 003 F0204

Output	Switch 3					
	1	2	3	4	5	6
0...5 V						
0...10 V						
1...5 V						
2...10 V						
-10...+10 V						
-5...+5 V						
-10...0 V						
-5...0 V						
0...6.66 V						
-10...+3.33 V						
-5...+1.66 V						
0...8 V						
0...4 V						
-10...-2 V						
-5...-1 V						
1.25...6.25 V						
-7.5...+2.5 V						
-3.75...+1.25 V						
1.66...8.33 V						
-6.66...+6.66 V						
-3.33...+3.33 V						
-8...0 V						
-4...0 V						
0...1 mA						
0...20 mA						
4...20 mA						
0...10 mA						
0...0.5 mA						
0...13.33 mA						
0...666 μA						
0...16 mA						
0...800 μA						
0...8 mA						
0...400 μA						
2.5...12.5 mA						
125...625 μA						
3.33...16.66 mA						
166...833 μA						
0.2...1 mA						
2...10 mA						
100...500 μA						

2CDC 282 024 F0203

2CDC 282 003 F0204

Legend	
ON	■
OFF	□
no influence	■

Analog signal converters - CC-U range

DIP switch settings

CC-U/V

Output	Switch					
	1	2	3	4	5	6
0...5 V						
0...10 V						
1...5 V						
2...10 V						
-10...+10 V						
-5...+5 V						
-10...0 V						
-5...0 V						
0...6.66 V						
-10...+3.33 V						
-5...+1.66 V						
0...8 V						
0...4 V						
-10...-2 V						
-5...-1 V						
1.25...6.25 V						
-7.5...+2.5 V						
-3.75...+1.25 V						
1.66...8.33 V						
-6.66...+6.66 V						
-3.33...+3.33 V						
-8...0 V						
-4...0 V						
0...1 mA						
0...20 mA						
4...20 mA						
0...10 mA						
0...0.5 mA						
0...13.33 mA						
0...666 μA						
0...16 mA						
0...800 μA						
0...8 mA						
0...400 μA						
2.5...12.5 mA						
125...625 μA						
3.33...16.66 mA						
166...833 μA						
0.2...1 mA						
2...10 mA						
100...500 μA						

2CDC 282 003 F0204 2CDC 282 029 F0203

Legend	
■	ON
□	OFF
□	no influence

CC-U/TC

Output	Switch 3					
	1	2	3	4	5	6
0...5 V						
0...10 V						
1...5 V						
2...10 V						
-10...+10 V						
-5...+5 V						
-10...0 V						
-5...0 V						
0...6.66 V						
-10...+3.33 V						
-5...+1.66 V						
0...8 V						
0...4 V						
-10...-2 V						
-5...-1 V						
1.25...6.25 V						
-7.5...+2.5 V						
-3.75...+1.25 V						
1.66...8.33 V						
-6.66...+6.66 V						
-3.33...+3.33 V						
-8...0 V						
-4...0 V						
0...1 mA						
0...20 mA						
4...20 mA						
0...10 mA						
0...0.5 mA						
0...13.33 mA						
0...666 μA						
0...16 mA						
0...800 μA						
0...8 mA						
0...400 μA						
2.5...12.5 mA						
125...625 μA						
3.33...16.66 mA						
166...833 μA						
0.2...1 mA						
2...10 mA						
100...500 μA						

2CDC 282 017 F0208

Legend	
■	ON
□	OFF
□	no influence

Type	Input Range	Switch 1						Switch 2							
		1	2	3	4	5	6	1	2	3	4	5	6		
K	0-100...900 °C														
J	0-250...1350 °C														
J	0-100...750 °C														
T	0-100...400 °C														
T	-150-0...400 °C														
S	0-250...1550 °C														
E	0-100...700 °C														
E	0-200...1000 °C														
N	0-100...650 °C														
N	0-200...1300 °C														
R	0-250...1350 °C														
R	0-450...1700 °C														
B	0-700...1750 °C														
mV	0-2...10 mV														
mV	0-10...50 mV														
Low fall safe *)															
High fall safe *)															

2CDC 282 010 F0204

*) Detection of input signal interruptions:

If the input signal circuit is interrupted, the output signal changes to the adjusted minimum value (low fall safe) or maximum value (high fall safe).

CC-U/I

Output	Switch					
	1	2	3	4	5	6
0...5 V						
0...10 V						
1...5 V						
2...10 V						
-10...+10 V						
-5...+5 V						
-10...0 V						
-5...0 V						
0...6.66 V						
-10...+3.33 V						
-5...+1.66 V						
0...8 V						
0...4 V						
-10...-2 V						
-5...-1 V						
1.25...6.25 V						
-7.5...+2.5 V						
-3.75...+1.25 V						
1.66...8.33 V						
-6.66...+6.66 V						
-3.33...+3.33 V						
-8...0 V						
-4...0 V						
0...1 mA						
0...20 mA						
4...20 mA						
0...10 mA						
0...0.5 mA						
0...13.33 mA						
0...666 μA						
0...16 mA						
0...800 μA						
0...8 mA						
0...400 μA						
2.5...12.5 mA						
125...625 μA						
3.33...16.66 mA						
166...833 μA						
0.2...1 mA						
2...10 mA						
100...500 μA						

2CDC 282 003 F0204 2CDC 282 029 F0203

Legend	
■	ON
□	OFF
□	no influence

CC-U/TCR with relay output

Type	Input Range	Switch					
		1	2	3	4	5	6
J	0...240 °C						
J	0...480 °C						
K	0...1200 °C						
K	0...500 °C						
K	0...1350 °C						
T	-150...+120 °C						
T	0...220 °C						
T	0...400 °C						
S	0...210 °C						
S	0...380 °C						
S	0...860 °C						
S	0...1550 °C						
Output							
Closed-circuit principle							
Open-circuit principle							

2CDC 282 004 F0204

Legend	
■	ON
□	OFF
□	no influence

Analog signal converters - CC-U range

Wiring instructions

CC-U/STD

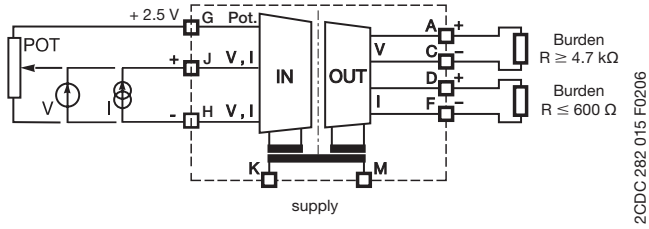

CC-U/STDR with relay output

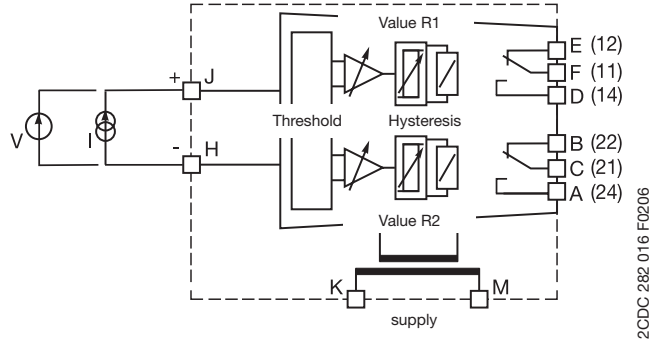

CC-U/RTD

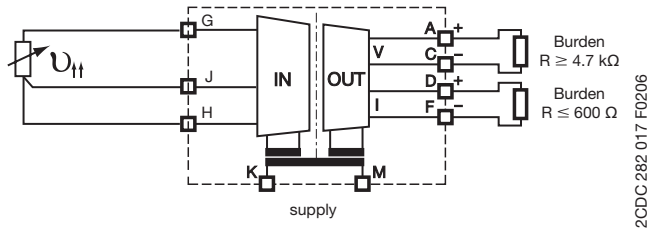

CC-U/RTDR with relay output

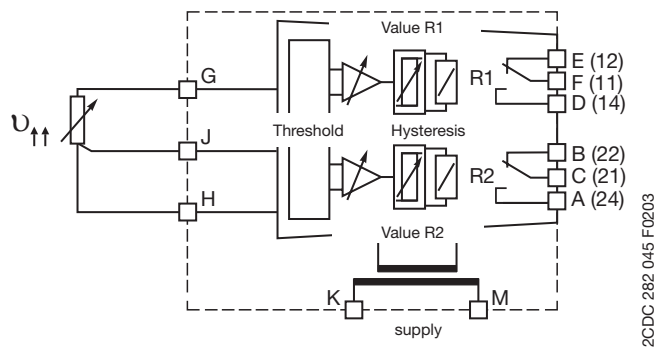

CC-U/V

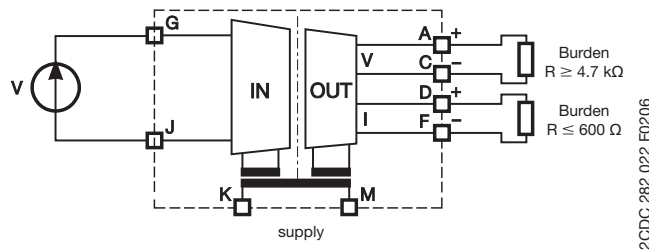

CC-U/I

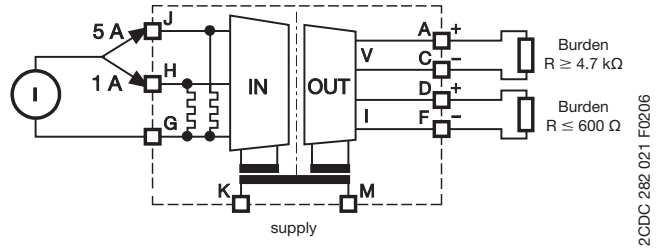

CC-U/TC

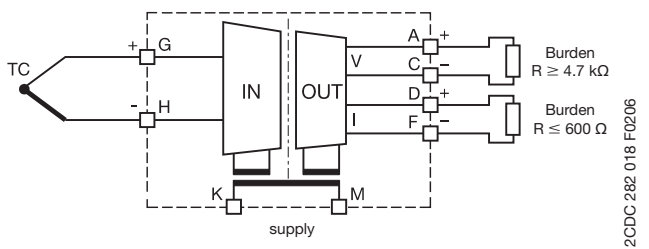

CC-U/TCR with relay output

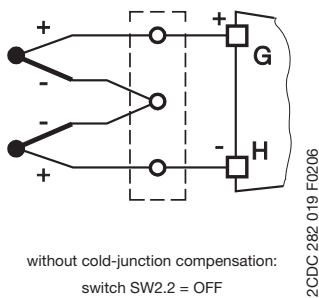
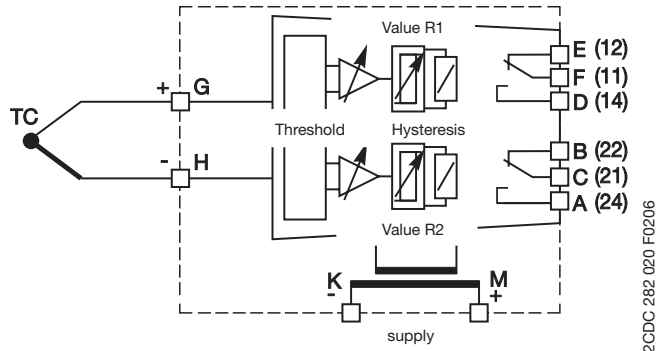

Analog signal converters - CC-U range

Technical information

CC-U/STD

Adjustment range

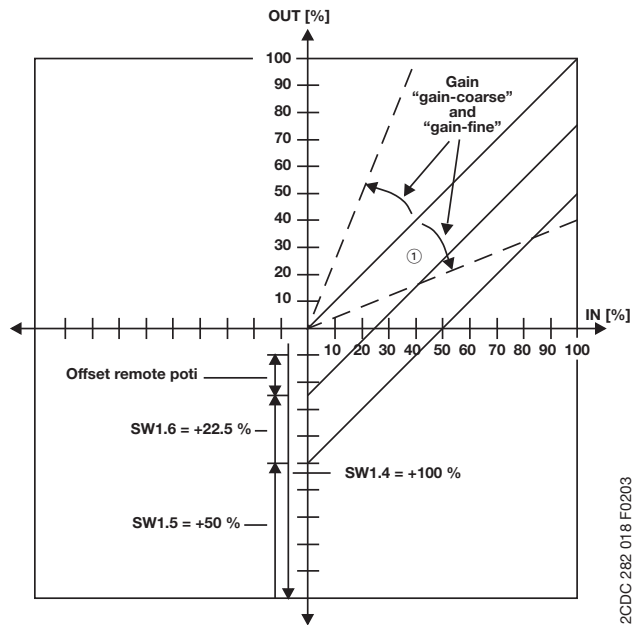

CC-U/STDR with relay output

Function diagrams

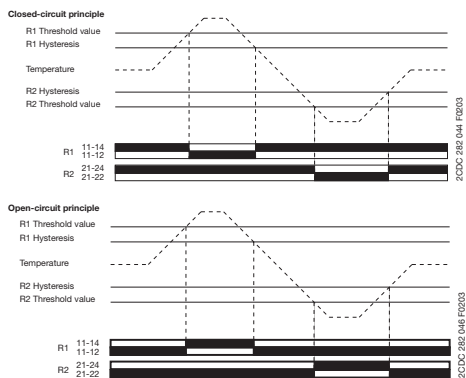

Switching points

Switching points of the output relay depending on the input range, configuration open-circuit principle

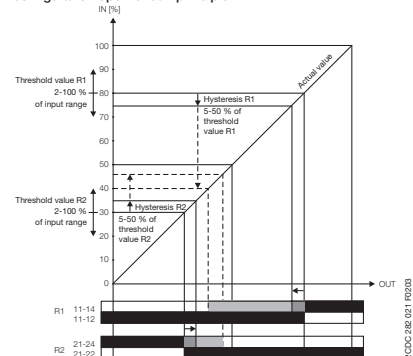

Analog signal converters - CC-U range

Technical information

CC-U/RTD

Characteristic curves

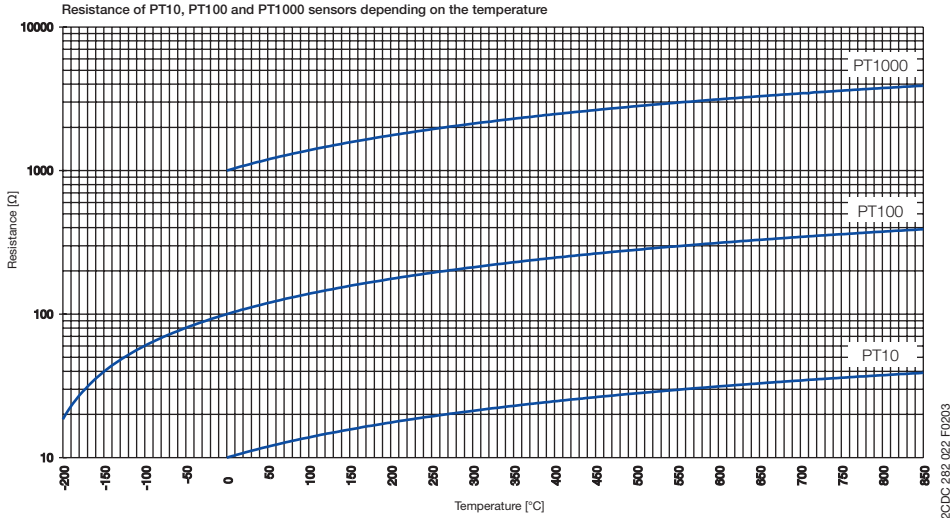

4

CC-U/RTDR with relay output

Switching points

Switching points of the output relay depending on the input range, configuration open-circuit principle

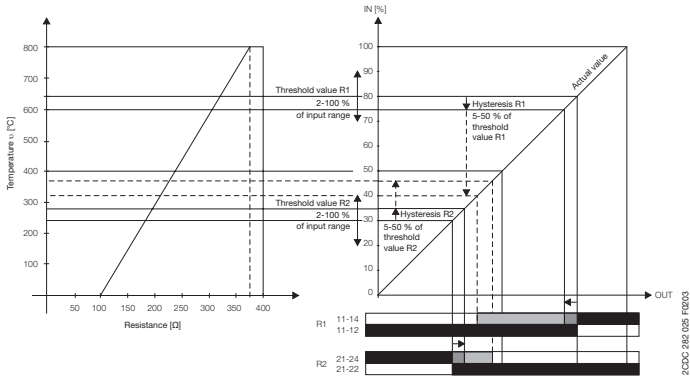

Function diagrams

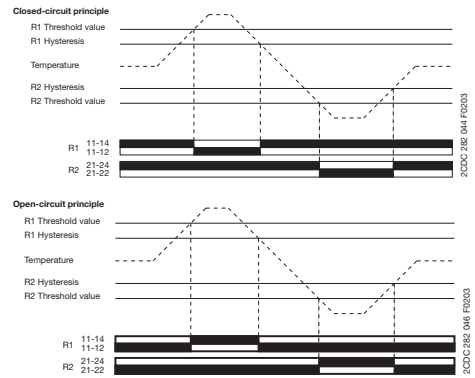

CC-U/V

Input range selection

Selecting input range by front-face rotary switch	Switch position
0...100 V	1
0...150 V	2
0...250 V	3
0...300 V	4
0...400 V	5
0...450 V	6
0...550 V	7
0...600 V	8

2CDC 282 012 F0204

Example of application

RMS measurement and conversion of a phase-angle controlled voltage signal $L1 = 230\text{ V}$

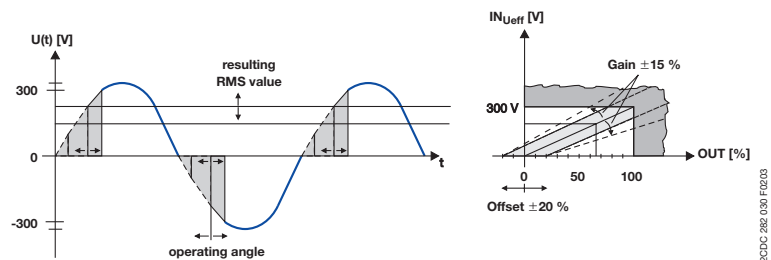

Analog signal converters - CC-U range

Technical information

CC-U/I

Input range selection

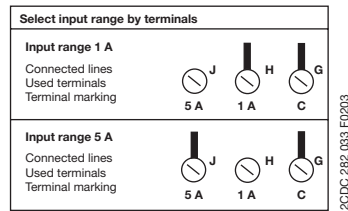

Example of application

RMS measurement and conversion of a current signal

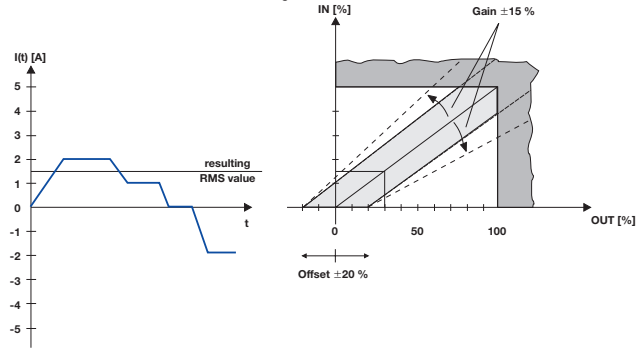

CC-U/TC

Characteristic curve

Thermocouple voltages depending on the temperature

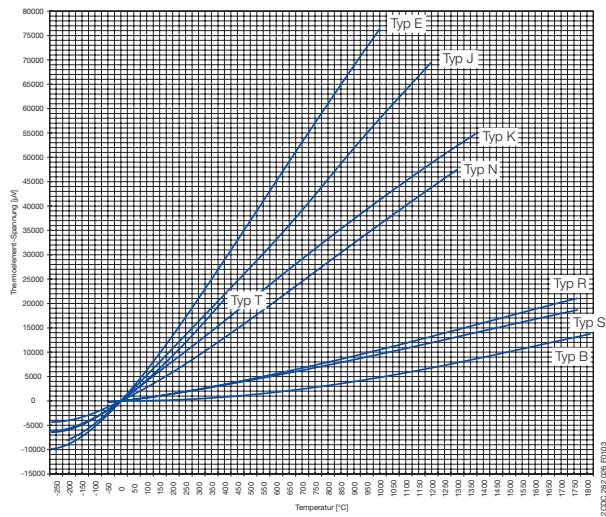

CC-U/TCR with relay output

Function diagrams

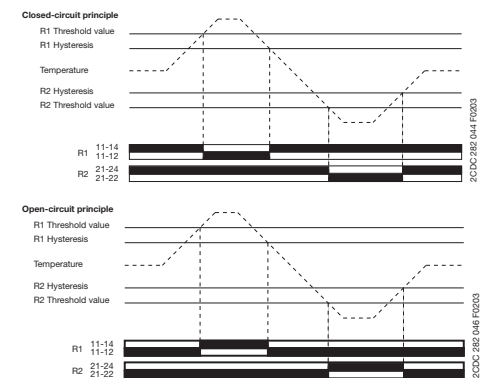

Switching points

Switching points of the output relay depending on the input range, configuration open-circuit principle

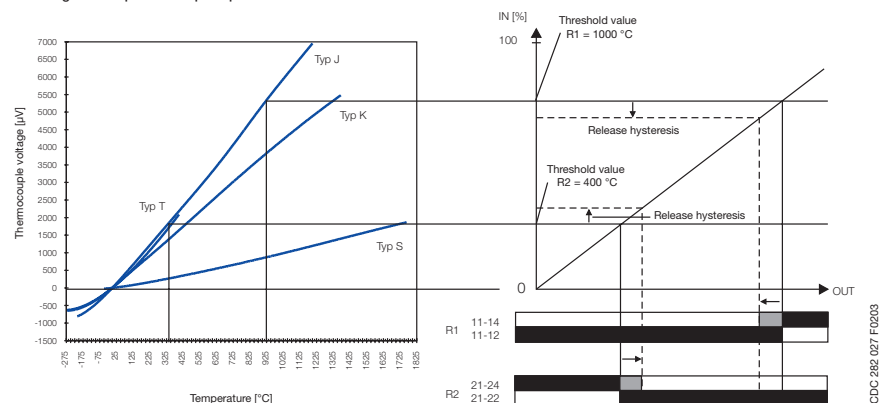

Analog signal converters - CC-U range

Technical data

4

Type	CC-U/STD			CC-U/RTD ³⁾	CC-U/TC	
Input circuits - Analog inputs	J-G-H	Current	Voltage	Potentiometer	Temperature sensors:	Thermocouples (IEC 584-1 and 2)
Input signal		0-20 mA 4-20 mA 10-50 mA 0-1 mA	0-100 mV 0-1 V 0-5 V 1-5 V 0-10 V 2-10 V ± 10 V	470 Ω - 1 MΩ ²⁾	PT10, PT100, PT1000 (IEL 751 and JICC 1604)	TC.K TC.J TC.T TC.S TC.E TC.N TC.R TC.B
Limitation of input signals		± 55 mA	± 11 V			
Rated input range		-	-	-	Max. temperature adjustable: 6-60 °C for PT1000 50-500 °C for PT100 500-850 °C for PT10	refer to temperature specs. of individual thermocouples
Influence of line resistance		-	-	-	0.015 °C/Ω	< 0.01 % / 100 Ω
Gain adjustment range (universal devices)		0.9- 110 mA	45 mV - 22 V	-	see DIP switch settings	
Offset adjustment range (universal devices)		-137.5...+62.5 %			± 5 %	± 10 %
Input impedance		for different ranges			-	-
without detection of input signal interruption		51 Ω	6 MΩ	3 GΩ	-	-
with detection of input signal interruption		51 Ω	3.5 MΩ	9.5 GΩ	-	-
Suppression at 50 Hz		-	-	-	-	> 40 dB
Common-mode rejection		-	-	-	120 dB	105 dB
Output circuits - Analog outputs	D-F, A-C	Current			Voltage	
Output signal		0-20 mA, 4-20 mA			0-5 V, 1-5 V, 0-10 V, 2-10 V, ± 10 V	
Output burden		≤ 600 Ω			≥ 4,7 KΩ	
Accuracy ¹⁾		±0.1 % of full-scale			±0.2 % of full-scale	±0.1 % of full-scale
Residual ripple		-			< 0.15 %	-
Response time		200 μs			10 ms	200 ms
Transmission frequency		1 kHz			80 Hz	2 Hz (to -3 dB)
Supply circuits	K-M	DC versions			AC versions	
Rated supply voltage		24-48 V DC			110-240 V AC	
Supply voltage range		24-48 V DC / 24 V AC			110-240 V AC / 100-300 V DC	
Supply voltage tolerance		DC: -15...+15 %			AC: -15...+10 %	
Rated frequency		0 Hz or 50/60 Hz				
Power consumption		2 W at 24 V DC			4.5 VA at 230 V AC	
Indication of operational states		U: green LED				
General data						
Ambient temperature range operation / storage		-20...+60 °C / -40...+80 °C				
Temperature coefficient		±150 ppm/°C			±250 ppm/°C	±200 ppm/°C at min. offset ±400 ppm/°C at max. offset
Mounting position		any				
Mounting		DIN rail (IEC/EN 60715), snap-on mounting / screw mounting with adapter				
Electrical connection						
Wire size	rigid	plug-connector with screw terminals 0.2-2.5 mm ² (24-12 AWG)				
	fine-strand with(out) wire end ferrule	plug-connector with screw terminals 0.2-2.5 mm ² (24-12 AWG)				
Stripping length		7 mm (0.28 inch)				
Tightening torque		0.4 Nm (3.5 lb.in)				
Electromagnetic compatibility						
Interference immunity		EN 61000-6-2				
electrostatic discharge (ESD)	IEC/EN 61000-4-2	Level 3 (±6 kV / ±8 kV)				
electromagnetic field (HF radiation resistance)	IEC/EN 61000-4-3	10 V/m				
fast transients (Burst)	IEC/EN 61000-4-4	Level 3 (±2 kV / 5 kH)				
powerful impulses (Surge)	IEC/EN 61000-4-5	±2 kV / ±1 kV				
HF line emission	IEC/EN 61000-4-6	10 V				
Interference emission	EN 61000-6-4	Class B				
Isolation data						
Isolation test (between all isolated circuits)		1.5 kV				
Test voltage (between all isolated circuits)		1.5 kV / 50 Hz				

¹⁾ Includes non-linearity and factory setting, influenced by supply voltage and output load.

²⁾ Detection of an input signal break (fail safe) and resistance > 10 kΩ results in a linearity of ±0,2 %.

³⁾ When connecting a 2-wire sensor, the terminals J and H have to be jumpered.

Approvals on page 4/4.

Analog signal converters - CC-U range

Technical data

Type		CC-U/STDR	CC-U/RTDR ¹⁾	CC-U/TCR
Input circuits - Analog inputs	J-H	Current	Voltage	Temperature sensors
Measuring signal / input range		0-20 mA 4-20 mA	0-1 V / 1-5 V 0-10 / ±10 V	PT100 TC.K, TC.J TC.T, TC.S
Input resistance		approx. 50 Ω	approx. 1,5 MΩ	
Adjustable threshold		2-100 % of selected input range		
Adjustable hysteresis		5-50 % of threshold		
Repeat accuracy (constant parameters)		±0.5 % of full-scale		
Output circuits - Relay outputs	E-D-F, B-C-A	Relay, 2 c/o contacts		
Rated switching voltage		250 V AC		
Rated switching current	AC12 (resistive) 230 V	4 A		
	AC15 (inductive) 230 V	3 A		
	DC12 (resistive) 24 V	4 A		
	DC13 (inductive) 24 V	2 A		
AC rating (UL 508)	Utilization category (Control Circuit Rating Code)	B 300		
	max. rated operational voltage	300 V AC		
	max. continuous thermal current at B 300	5 A		
	max. making/breaking apparent power at B 300	3600/360 VA		
Minimum switching voltage		12 V		
Minimum switching current / power		10 mA / 0.6 VA (W)		
Response time		10 ms		
Mechanical lifetime		30 x 10 ⁶ switching cycles		
Electrical lifetime	at AC12, 230 V, 4 A	0.1 Mio. switching cycles		
Supply circuits	K-M	DC versions	AC versions	
Rated supply voltage		24-48 V DC	110-240 V AC	
Supply voltage range		24-48 V DC / 24 V AC	110-240 V AC / 100-300 V DC	
Supply voltage tolerance		DC: -15...+15 %	AC: -15...+10 %	
Rated frequency		0 Hz or 50/60 Hz		
Power consumption		2 W at 24 V DC	4.5 VA at 230 V AC	
Indication of operational states				
Supply voltage		U: green LED		
1st / 2nd output relay energized		R1: yellow LED / R2: yellow LED		
General data				
Ambient temperature range	operation / storage	-20...+60 °C / -40...+80 °C		
Temperature coefficient		±300 ppm/°C		
Mounting position		any		
Mounting		DIN rail (IEC/EN 60715), snap-on mounting / screw mounting with adapter		
Electrical connection				
Wire size	rigid	plug-connector with screw terminals 0.2-2.5 mm ² (24-12 AWG)		
	fine-strand with(out) wire end ferrule	plug-connector with screw terminals 0.2-2.5 mm ² (24-12 AWG)		
Stripping length		7 mm (0.28 inch)		
Tightening torque		0.4 Nm (3.5 lb.in)		
Electromagnetic compatibility				
Interference immunity		EN 61000-6-2		
electrostatic discharge (ESD)	IEC/EN 61000-4-2	Level 3 (±6 kV / ±8 kV)		
electromagnetic field (HF radiation resistance)	IEC/EN 61000-4-3	10 V/m		
fast transients (Burst)	IEC/EN 61000-4-4	Level 3 (±2 kV / 5 kH)		
powerful impulses (Surge)	IEC/EN 61000-4-5	±2 kV / ±1 kV		
HF line emission	IEC/EN 61000-4-6	10 V		
Interference emission	EN 61000-6-4	Class B		
Isolation data				
Insulation voltage (between all isolated circuits)		2.5 kV		
Test voltage (between all isolated circuits)		2.5 kV		

¹⁾ When connecting a 2-wire sensor, the terminals J and H have to be jumpered.

Approvals on page 4/4.

Analog signal converters - CC-U range

Technical data

4

Type		CC-U/I	CC-U/V
Input circuits - Analog inputs	J-G-H	any current signals, RMS measurement	any voltage signals, RMS measurement
Rated input range		0-1 A 0-5 A	0-100 V, 0-200 V 0-300 V, 0-400 V 0-500 V, 0-600 V
Measuring frequency		0-600 Hz	
Overload capacity of inputs	input range 1	$10 \times I_{Nom}$ (10 A) for max. 2 s	-
	input range 2	$10 \times I_{Nom}$ (50 A) for max. 2 s	-
Gain adjustment range		±15 %	
Offset adjustment range		±20 %	
Input impedance / resistance		1A: 60 mΩ, 5 A: 12 mΩ	> 800 kΩ
Output circuits - Analog outputs	D-F, A-C	Current	Voltage
Output signal		0-20 mA, 4-20 mA	0-5 V, 1-5 V, 0-10 V, 2-10 V, ± 10 V
Output load		≤ 600 Ω	≥ 4.7 kΩ
Accuracy ¹⁾		±0.5 % of full-scale	
Temperature coefficient		±250 ppm/°C max.	±300 ppm/°C max.
Residual ripple		< 0.15 %	
Response time		150 ms	
Supply circuits	K-M	DC versions	AC versions
Rated supply voltage		24-48 V DC	110-240 V AC
Supply voltage range		24-48 V DC, 24 V AC	110-240 V AC, 100-300 V DC
Supply voltage tolerance		DC: -15...+15 %	AC: -15...+10 %
Rated frequency		0 Hz or 50/60 Hz	
Power consumption		2 W at 24 V DC	4.5 VA at 230 V AC
Indication of operational states			
Supply voltage		U: green LED	
General data			
Ambient temperature range	operation / storage	-20...+60 °C / -40...+80 °C	
Mounting position		any	
Mounting		DIN rail (IEC/EN 60715), snap-on mounting / screw mounting with adapter	
Electrical connection			
Wire size	rigid	plug-connector with screw terminals 0.2-2.5 mm ² (24-12 AWG)	
	fine-strand with(out) wire end ferrule	plug-connector with screw terminals 0.2-2.5 mm ² (24-12 AWG)	
Stripping length		7 mm (0.28 inch)	
Tightening torque		0.4 Nm (3.5 lb.in)	
Standards			
Product standard		-	
Low Voltage directive		2006/95/EG	
EMC directive		2004/108/EG	
RoHS directive		2002/95/EG	
Electromagnetic compatibility			
Interference immunity		EN 61000-6-2	
electrostatic discharge (ESD)	IEC/EN 61000-4-2	Level 3 (±6 kV / ±8 kV)	
electromagnetic field (HF radiation resistance)	IEC/EN 61000-4-3	10 V/m	
fast transients (Burst)	IEC/EN 61000-4-4	Level 3 (±2 kV / 5 kH)	
powerful impulses (Surge)	IEC/EN 61000-4-5	±2 kV / ±1 kV	
HF line emission	IEC/EN 61000-4-6	10 V	
Interference emission	EN 61000-6-4	Class B	
Isolation data			
Insulation voltage (between all isolated circuits)		1.5 kV	
Test voltage (between all isolated circuits)		1.5 kV / 50 Hz	

¹⁾ Includes non-linearity and factory setting, influenced by supply voltage and output load.

Approvals on page 4/4.

Analog signal converters - CC-U range

Technical diagr., Connection diagr., Dimensional drawings

Technical diagrams

Load limit curves CC-U/xxR

Resistive AC load

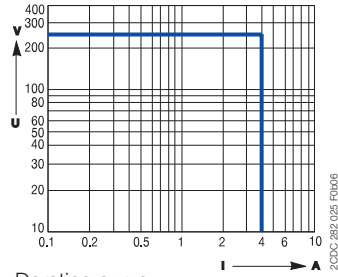

Resistive DC load

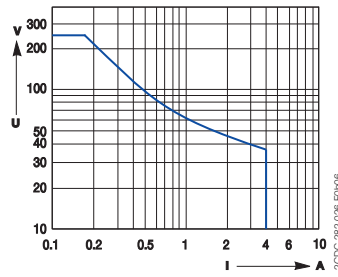

Derating curve

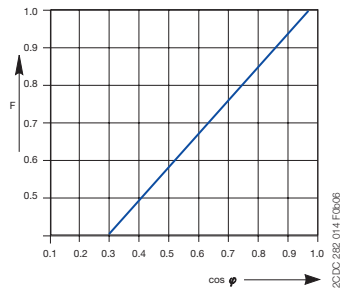

Connection diagram CC-U/x

Width 22.5 mm (0.89 in)

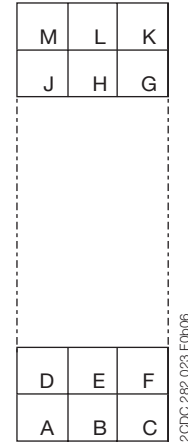

4

Dimensional drawings

Dimensions in mm and inches

CC-U/x , CC-U/xR

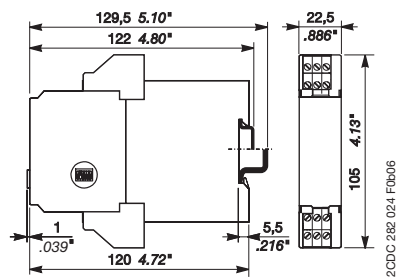

Serial data converters

Product picture

4



Serial data converters

Table of contents

Serial data converters	
Product picture	4/33
Table of contents	4/34
Benefits and advantages	4/35
Selection table	4/36
Ordering details	4/37
Connection diagrams and jumper settings	4/38
Technical data	4/45
Dimensional drawings	4/55
Notes	4/56

Serial data converters

Benefits and advantages

4

ILPH RS 232 - 485 / Ethernet

- Electrical isolation between power supply and input/output
- RS232 on SUBD 9 points or screw connectors
- RS485 on removable screw connectors
- Ethernet 10/100 Mbit/s, RJ45 connector
- Power supply 10-34 VDC and 10-24 VAC
- Possible to have a redundant 10-34 VDC power supply
- Economic with low consumption
- Up to 100m with CAT5 cable without Hub or Switch
- Good EMC characteristics
- Up to 2 Modbus@TCP Masters

Available modes:

- Modbus@TCP to Modbus@ RTU
- Transparent Client or Server mode
- SMTP mode (Mail mode)

Standards: TPC/IP, TELNET, DHCP, FTP

- Specifics functions in Modbus@ protocol:
- Concentrator (Asynchronous mode) up to 1200 words
- AC31 programming
Modbus@ Easy Net mode : this mode could be used to exchange data without a Modbus@/TCP master. The data are logged in a table and could be distributed to one or all the others e-ILPH participants on Ethernet.

ILPH RS 232 / RS 422 - 485

- Electrical isolation between power supply and input/output
- RS 485 switch on 2 or 4 wires
- Baudrate up to 38.4 kbit/s
- Transmission distance up to 1200 m
- RS 485 1 or 2 pair handling
- Usable in "noisy" environments
- 24...48 V DC and 115...230 V AC power supply
- CE marked

ILPH RS 422 - 485 / RS 422 - 485

Electrical isolated connection between an RS 422-485 (1 or 2 pairs) and an RS 422 485 (1 or 2 pairs) serial link. It amplifies the signal beyond the 1200 m limit distance of the RS 422-485 and only needs a minimum of 1.5 character delay time to switch off the RS 485 drivers.

- Electrical isolation between power supply/output and input/output
- Baudrate up to 500 kbit/s (up to 200 m)
- Transmission distance up to 1200m at 38.4 kbit/s
- Usable in "noisy" environments
- 2/4 wires automatic handling
- 24 V DC power supply
- CE marked

ILPH RS 232 / RS 422 - 485

RS 232 to RS 422-485 serial link with or without electrical isolation

- Baudrate up to 38.4 kbit/s
- Transmission distance up to 1200 m
- RS 485 1 or 2 pair handling
- Usable in "noisy" environments
- 24 V DC power supply
- CE marked

ILPH RS 485 / FO

Converter for RS 485 (1 pair) to optical fiber serial link glass (S) or plastic (P).

- Electrical isolation between power supply and input/output
- Baud rate up to 1.5 Mbit/s
- Available for glass fiber or plastic fiber
- Transmission distance up to 4 km
- Usable in "very noisy" environments
- 20...42 V AC/DC and 110...240 V AC/DC power supply
- CE marked

ILPH RS 232 / CL

Electrical isolated Converter for RS 232 to current loop serial link.

- Electrical isolation between power supply/current loop and RS 232/ current loop
- Active/Passive 0...20 mA / 4...20 mA selectable
Positive or negative logic selectable
- Baudrate up to 38.4 kbit/s
- Transmission distance up to 1200 m
- Usable in "noisy" environments
- 24 V DC power supply
- CE marked

ILPH RS 232 / RS 232

3 way electrical isolator between RS 232 serial interface and another RS 232 serial interface.

- Ensures triple insulation between the 2 serial interfaces and between each and power supply
- Baudrate up to 19.2 kbit/s (up to 64 kbit/s depending on cable)
- Transmission distance up to 15 m
- Can be used in "noisy" environments
- Power supply from 24...48 V DC and 115...230 V AC CE marking

ILPH RS 232 / FO

Converter for RS 232 to fiber optical serial link glass (S) or plastic (P).

- Electrical isolation between power supply and input/output
- Baud rate up to 115.2 kbit/s
- Available for glass or plastic fiber
- Transmission distance up to 4 km
- Usable in "very noisy" environments
- 20...42 V AC/DC and 110...240 V AC/DC power supply
- CE marked

ILPH CL / RS 422 - 485

Electrical isolated converter for current loop to RS 422-485 (1 or 2 pairs) serial link.

- Electrical isolation between power supply/current loop and RS 422-485/ current loop
- Active/passive 0...20 mA / 4...20 mA selectable
Positive or negative logic selectable
- Baudrate up to 38.4 kbit/s (up to 2400 m)
Transmission distance up to 2400 m (1200 m RS 485 and 1200 m current loop)
- Usable in "noisy" environments
- 24 V DC power supply
- CE marked

Serial data converters

Selection table

	RS232	RS422 / RS485	CL	OF-S	OF-P	Ethernet	24 V DC	24-48 V DC	110-240 V AC	24-42 V AC/DC	10-34 VDC; 10-24 VAC	Insulation *	Part numbers
RS232	■							■				In-Ps-Out	1SNA 684 234 R2000
	■								■			In-Ps-Out	1SNA 684 244 R0200
		■					■					Wi	1SNA 684 231 R2500
		■					■					In-Out	1SNA 684 233 R2700
		■						■				In-Ps-Out	1SNA 684 333 R2300
		■							■			In-Ps-Out	1SNA 684 334 R2400
			■				■					In-Out	1SNA 684 202 R0100
				■						■		In-Ps-Out	1SNA 684 236 R2200
				■					■			In-Ps-Out	1SNA 684 237 R2300
					■				■			In-Ps-Out	1SNA 684 238 R0400
					■				■			In-Ps-Out	1SNA 684 239 R0500
RS422 /RS485		■					■					In-Out	1SNA 684 212 R2200
			■				■					In-Out	1SNA 684 232 R2600
RS485				■					■			In-Ps-Out	1SNA 684 246 R0400
				■					■			In-Ps-Out	1SNA 684 247 R0500
					■				■			In-Ps-Out	1SNA 684 248 R1600
					■				■			In-Ps-Out	1SNA 684 249 R1700
RS232 / RS485					■					■	In-Ps-Out	1SNA 684 252 R0200	

* In=Input, Ps=Power supply, Out=Output, Wi=Without insulation

- RS 232 - EIA-232 / V.24 / V.28**
 Point-to-point connection
 Max. 15 m transmission distance
 Rate up to 19.2 kbit/s
 Full-duplex
- RS 422 - EIA-422 / V.11**
 Point-to-point connection
 (1 Transmitter - 10 Receivers)
 Differential voltage transmission
 Full-duplex
 Up to 1200 m/ 10Mbit/s
 Good EMC characteristics
- Current loop(TTY)**
 Point-to-point / multi-point connection
 Active or passive current loop
 Full-duplex
 Up to 1200 m/19.2 kBit/s
 Good EMC characteristics
- RS 485 - ISO/IEC/EIA-485**
 Multi-point connection up to 32 units
 Differential voltage transmission
 Half-duplex on 1 pair
 Full-duplex on 2 pairs
 Up to 1200 m / 10Mbit/s
 Good EMC characteristics
- Optical fiber interface**
 Point-to-point connection
 Full-duplex
 From 40m up to 4km transmission distance
 according to optical fiber material (plastic / glass)
 and wavelength used up to 10 Mbit/s
 Excellent EMC characteristics
- Ethernet Interface**
 Point to point connexion or multipoint connection.
 Up to 100m using CAT5 cable without Hub or Switch
 10/100 Mbit/s
 Good EMC characteristics

Serial data converters

Ordering details



2CDC 281 003 R0013

4 ILPH RS 232-RS 485 / Ethernet



2CDC 281 001 S0013

ILPH RS 232 / RS 422-485

Ordering details

Description	Type	Order code	Price	Weight (1 pce) kg (lb)
Serial data converter e-ILPH	ILPH RS 232-RS 485 / Ethernet	1SNA684252R0200		0.12 (0.265)
Serial link interface without electrical isolation	ILPH RS 232 / RS 422-485	1SNA684231R2500		0.1 (0.220)
Serial link interface with electrical isolation	ILPH RS 232 / RS 422-485	1SNA684233R2700		0.1 (0.220)
Serial link interface 3 way electrical isolation	ILPH RS 232 / RS 422-485 (24-48 V DC power supply)	1SNA684333R2300		0.1 (0.220)
	ILPH RS 232 / RS 422-485 (115-230 V DC power supply)	1SNA684334R2400		
Serial link interface 3 way electrical isolation	ILPH RS 232 / RS 232 (24-48 V DC power supply)	1SNA684234R2000		0.1 (0.220)
	ILPH RS 232 / RS 232 (115-230 V DC power supply)	1SNA684234R0200		
Serial link interface with electrical isolation	ILPH RS 422 - 485 / RS 422 - 485 (24 V DC power supply)	1SNA684212R2200		0.1 (0.220)
Serial link interface 3 way electrical isolation	ILPH RS 232 / FO-S (24...42 V AC/DC power supply)	1SNA684236R2200		0.15 (0.331)
	ILPH RS 232 / FO-S (110...240 V AC/DC power supply)	1SNA684237R2300		
	ILPH RS 232 / FO-P (24...42 V AC/DC power supply)	1SNA684238R0400		
Serial link interface 3 way electrical isolation	ILPH RS 232 / FO-P (110...240 V AC/DC power supply)	1SNA684239R0500		0.15 (0.331)
	ILPH RS 485 / FO-S (24...42 V AC/DC power supply)	1SNA684246R0400		
	ILPH RS 485 / FO-S (110...240 V AC/DC power supply)	1SNA684247R0500		
Serial link interface with electrical isolation	ILPH RS 485 / FO-P (24...42 V AC/DC power supply)	1SNA684248R1600		0.1 (0.220)
	ILPH RS 485 / FO-P (110...240 V AC/DC power supply)	1SNA684249R1700		
Serial link interface with electrical isolation	ILPH BdC /RS 422 - 485 (24 V DC power supply)	1SNA684232R2600		0.1 (0.220)
Serial link interface with electrical isolation	ILPH RS 232 (24 V DC power supply)	1SNA684202R0100		0.1 (0.220)

Serial data converters

Connection diagrams, Jumper settings

ILPH RS 232 - 485 Ethernet (without isolation)

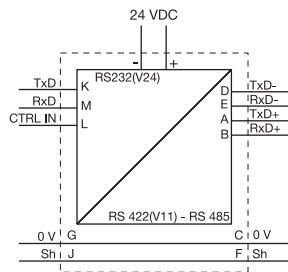

RS 422 - RS 485 SERIAL LINK (2 wires)

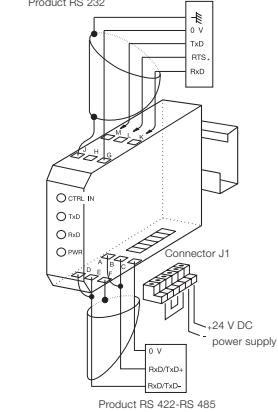

***CAUTION:**
When the RTS Signal is not activated, M terminal (RxD ILPH) has to be connected to L terminal (CTRL IN).

RS 422 - RS 485 SERIAL LINK (4 wires)

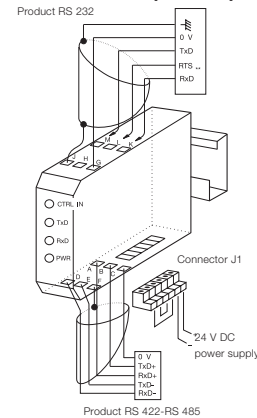

**** CAUTION :**
To be connected to 2 wired RS 485 only (not possible for 4 wired RS 422). When the RTS Signal is not activated, M terminal (RxD ILPH) has to be connected to L terminal (CTRL IN).

RS 485 LINK ON ONE PAIR

without isolation	R		R ON/OFF	Jumper R in position RON/OFF
	E		E ON/OFF	Jumper E in position EON/OFF

The Receiver and the Transmitter are activated alternately (never at the same time) depending on the status of the CTRL IN signal.

CTRL IN STATUS	ACTION ON RS 485
0 logic (+3V ≤ U ≤ +25V)	Transmitter active / Receiver inactive
1 logic (-25V ≤ U ≤ -3V)	Transmitter inactive / Receiver active
High impedance	Transmitter inactive / Receiver active

NOTE : For RS 232 products running the RTS (REQUEST TO SEND) signal, connect RTS to CTRL IN. Otherwise, connect M (RxD ILPH) to L (CTRL IN).

POLARIZATION OF THE RS 422 - RS 485 LINE

The line must always be polarized.
The ILPH is used to polarize the reception channel :

Connection by 1 wire	P+ (J1.1) with 5V (J1.4)
Connection by 1 wire	P- (J1.2) with 0V (J1.3)

RS 485 LINK ON TWO PAIRS

without isolation	R		R ON	Jumper R in position RON
	E		E ON/OFF	Jumper E in position EON/OFF

Receiver permanently active
Transmitter controlled by the signal CTRL IN (see table for Transmitter operation as a function of CTRL IN)

RS422 LINK ON TWO PAIRS

without isolation	R		R ON	Jumper R in position RON
	E		E ON	Jumper E in position EON

The Transmitter and Receiver are both permanently active.

ADAPTING THE RS 422 - RS 485 LINE

The line must always be adapted to the level of the reception channel of each subscriber forming the end of the bus. The ILPH is used to adapt the reception channel by setting the jumper Rt correctly :

Rt		* Line adaptation, Rt = 120 Ω (general case)
		* Line adaptation, Rt = 220 Ω
		* No line adaptation, Rt = ∞

Serial data converters

Connection diagrams, Jumper settings

ILPH RS 232 - 485 Ethernet (isolated)

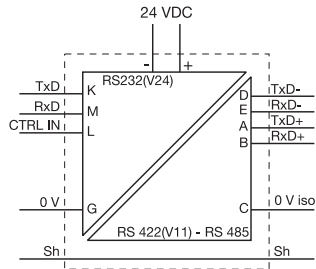

4

RS 422 - RS 485 WIRE SERIAL LINKS

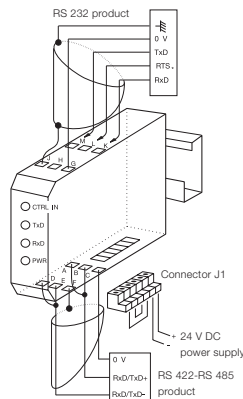

* CAUTION :

If the RTS signal is not generated, connect M (RxD ILPH) to L (CTRL IN).

RS 422 - RS 485 4 WIRE SERIAL LINKS

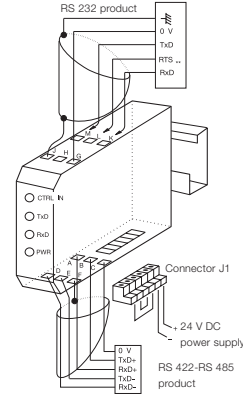

** CAUTION :

Only to be connected for RS 485 two pairs (of no use for RS 422 two pairs). If the RTS signal is not generated, connect M (RxD ILPH) to L (CTRL IN).

RS 485 LINK ON ONE PAIR

Isolated	R		R ON/ OFF	Jumper R in position RON/OFF
	E		E ON/ OFF	Jumper E in position EON/OFF

The Receiver and the Transmitter are activated alternately (never at the same time) depending on the status of the CTRL IN signal.

CTRL IN STATUS	ACTION ON RS 485
0 logic (+3V ≤ U ≤ +25V)	Transmitter active / Receiver inactive
1 logic (-25V ≤ U ≤ -3V)	Transmitter inactive / Receiver active
High impedance	Transmitter inactive / Receiver active

NOTE : For RS 232 products running the RTS (REQUEST TO SEND) signal, connect RTS to CTRL IN. Otherwise, connect M (RxD ILPH) to L (CTRL IN).

POLARIZATION OF THE RS 422 - RS 485 LINE

The line must always be polarized.
The ILPH is used to polarize the reception channel :

Connection by 1 wire	P+ (J1.1) with 5V (J1.4)
Connection by 1 wire	P- (J1.2) with 0V (J1.3)

RS 485 LINK ON TWO PAIRS

Isolated	R		R ON	Jumper R in position RON
	E		E ON/ OFF	Jumper E in position EON/OFF

Receiver permanently active
Transmitter controlled by the signal CTRL IN
(see table for Transmitter operation as a function of CTRL IN)

RS422 LINK ON TWO PAIRS

Isolated	R		R ON	Jumper R in position RON
	E		E ON	Jumper E in position EON

The Transmitter and Receiver are both permanently active.

ADAPTING THE RS 422 - RS 485 LINE

The line must always be adapted to the level of the reception channel of each subscriber forming the end of the bus. The ILPH is used to adapt the reception channel by setting the jumper Rt correctly :

Rt		* Line adaptation, Rt = 120 Ω (general case)
		* Line adaptation, Rt = 220 Ω
		* No line adaptation, Rt = ∞

Serial data converters

Connection diagrams, Jumper settings

ILPH RS 232 / CL

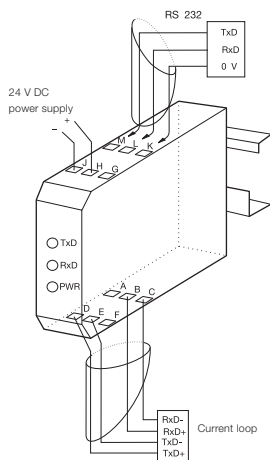
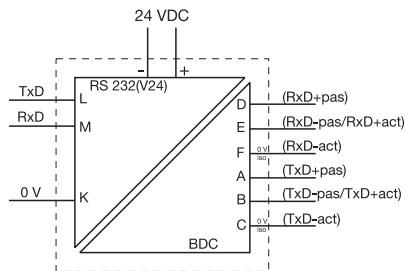

CONNECTIONS

Example of connection with a CL (Current Loop) product, Transmission (TxD) in active mode and Reception (RxD) in passive mode. Then, the ILPH must be configured and connected Reception (RxD) in passive mode and Transmission (TxD) in active mode.

CAUTION: For any other configuration, see schematic diagram or front sticker of the product.

CONFIGURATION

The various configurations can be selected using the 4 micro-switches located inside the box.

OPERATING MODE ACTIVE OR PASSIVE

The Current Loop's Transmission and Reception can be independently in active or passive mode.

Select operating mode using **S1** and **S2**.

- ON **S1** Transmission(TxD) ON = Active / OFF = Passive
- OFF **S2** Reception (RxD) ON = Active / OFF = Passive

SIGNAL LEVEL

Select signal level 4-20 mA or 0-20 mA. This selection is made using micro-switch S3

- ON **S3** ON = 4-20 mA / OFF = 0-20 mA

Caution :

It is not possible to select a 4-20 mA signal when the Reception is in active mode.

LOGIC LEVEL

- Configuration : Positive logic (0 Logic = 20 mA)
- or negative logic (1 Logic = 20 mA)

using micro-switch S4

- ON **S4** ON = (1 = 20 mA) / OFF = (0 = 20 mA)

ILPH RS 232 - 485 Ethernet (3 way electrical isolated)

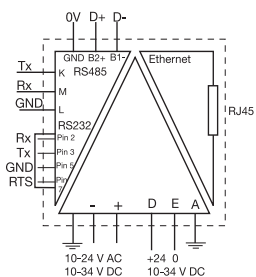

SubD9 connector
 pin 2 = RX
 pin 3 = TX
 pin 5 = GND
 pin 7 = RTS

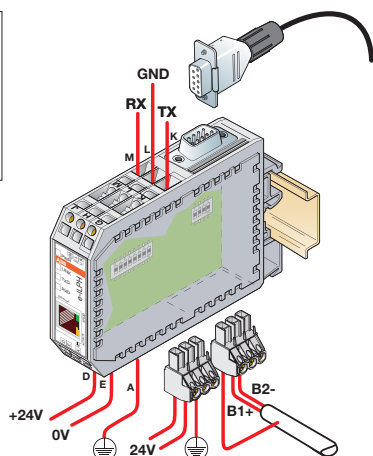

RS 485 LINK ON ONE PAIR

Set SW1-1, SW1-3, SW1-6, SW1-7 and SW1-8 to position ON. The receiver and the transmitter are activated alternately (never at the same time), depending on the status of the CTRL IN signal.

CTRL IN STATUS	Action on RS 485
0 Logic ($3V \leq U \leq +25V$)	Transmitter active / Receiver inactive
1 Logic ($-25V \leq U \leq -3V$)	Transmitter inactive / Receiver active
High impedance	Transmitter inactive / Receiver active

CAUTION : For RS 232 products running the RTS signal (REQUEST TO SEND), connect RTS to CTRL IN. Otherwise, set SW2-1 to position ON.

RS 485 LINK ON TWO PAIRS

Set SW1-1, SW1-3, SW1-7 in position OFF. Set SW1-6, SW1-8 in position ON. The receiver is permanently active. The transmitter is controlled by the signal CTRL IN (see table for transmitter operation as a function of CTRL IN).

RS 422 LINK ON TWO PAIRS

Set SW1-1, SW1-3, SW1-7 and SW1-8 in position OFF. Set SW1-6 in position ON. Transmitter and receiver are both permanently active.

POLARIZATION OF THE RS 422 - RS 485 LINE

The line must always be polarized. The ILPH is used to polarize the reception channel. Set SW1-4 and SW1-5 in position ON.

ADAPTING THE RS 422 - RS 485 LINE

The line must always be adapted to the level of the reception channel of each subscriber forming the end of the bus.

The ILPH is used to adapt the reception channel by setting the jumper SW1-2 correctly :

- SW1-2 in position ON \Rightarrow line adaptation $R_t = 120 \Omega$ (standard)
- SW1-2 in position OFF \Rightarrow no line adaptation $R_t = \infty$

Serial data converters

Connection diagrams, Jumper settings

ILPH CL / RS 422 - 485

Electrical isolated converter for current loop

LINE AMPLIFIER CONFIGURATION

Configuration of amplifiers of the RS 422 - RS 485 (Receiver, Transmitter) line provides greater flexibility of use. The various configurations can be selected using the 2 jumpers (R INT2, E INT1) located inside the box.

RS 485 LINK ON ONE PAIR

- R INT2 R ON/OFF Jumper R in position R ON/OFF
- E INT3 E ON/OFF Jumper E in position E ON/OFF

The Receiver and the Transmitter are activated alternately (never at the same time) depending on the status of the Current Loop Reception signal.

RS 485 LINK ON TWO PAIRS

- R INT2 R ON R ON Jumper R in position R ON
- E INT3 E ON/OFF E ON/OFF Jumper E in position E ON/OFF

Receiver permanently active. Transmitter controlled by the Current Loop Reception signal.

RS 422 LINK ON TWO PAIRS

- R INT2 R ON R ON Jumper R in position R ON
- E INT3 E ON E ON Jumper E in position E ON

The Receiver and the Transmitter are both permanently active.

POLARIZATION OF THE RS 422 - RS 485 LINE

The line must always be polarized. The ILPH is used to polarize the reception channel :

Connection by 1 wire P+ (J1.1) with 5 Viso (J1.4)

Connection by 1 wire P- (J1.2) with 0 Viso (J1.3)

ADAPTING THE RS 422 - RS 485 LINE

The line must always be adapted to the level of the reception channel of each subscriber forming the end of the bus. The ILPH is used to adapt the reception channel by setting the jumper Rt correctly :

- Rt INT1* Line adaptation, Rt = 120 Ω (Standard)
- Rt INT1* No line adaptation, Rt = ∞

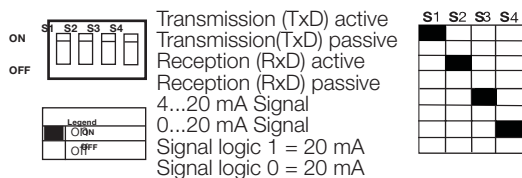

POLARIZATION

The polarization can be configured using the INT4 jumper.

- INT4 Protection ON
- INT4 Protection OFF, used if power supply at minimum value (21.6 V).

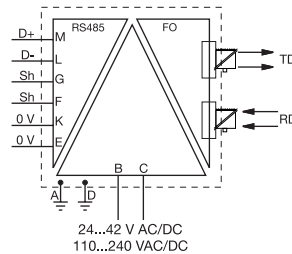

RS 422 - RS 485

2 wire serial link CONNECTIONS

Example of connection with a CL (current Loop) product, Transmission (TxD) in active mode and Reception (RxD) in passive mode.

Then, the ILPH must be configured and connected Reception (RxD) in passive mode and Transmission (TxD) in active mode.

Note : For any other configuration, see schematic diagram or front sticker of the product.

RS 422 - RS 485

4 wire serial link

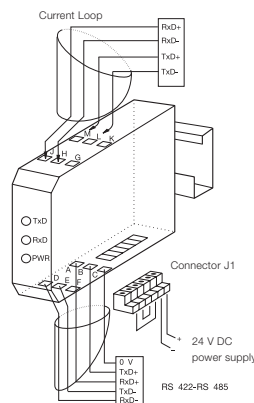

Note :

The TxD channel of the RS 422 - RS 485 link must be polarized independently too.

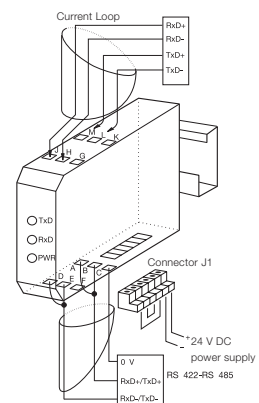

Serial data converters

Connection diagrams, Jumper settings

ILPH RS 422 - 485 / RS 422 / - 485

	INT 1	INT 2	INT 3	INT 4
BAUD RATE	1234	1234	1234	123456
FULL DUPLEX	0000	0000	XXX1	XXX101
500 Kb/s	1111	1111	XXX0	XXX000
187.5 Kb/s	1111	1110	XXX0	XXX000
93.75 Kb/s	1111	1100	XXX0	XXX000
38.4 Kb/s	1111	1000	XXX0	XXX000
19.2 Kb/s	1111	0000	XXX0	XXX000
9.6 Kb/s	1110	0000	XXX0	XXX000
4.8 Kb/s	1100	0000	XXX0	XXX000
2.4 Kb/s	1000	0000	XXX0	XXX000
1.2 Kb/s	0000	0000	XXX0	XXX000

N_U = not used
 X = zero
 1 = contact closed
 0 = contact open (aus)
 (off)

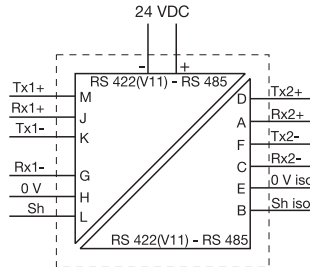

RS 422 - RS 485
2 wire serial link

RS 422 - RS 485
4 wire serial link

RS 422 - RS 485 DRIVERS CONTROL

The RS 422 - RS 485 Drivers Control (transmitters and receivers) makes the ILPH easy to use. The control of the 2 channels is completely automatic ; you only have to configure the baud rate needed.

The minimum turn off delay is about 1.5 character/time from 27 μs to 10 ms depending on the baud rate selected.

POLARIZATION OF THE RS 422 - RS 485 CONNECTIONS

The connections must always be polarized. The ILPH is used to polarize the reception channels:

INT 3



INT 3.1 } "ON", polarizes the
 INT 3.2 } reception channel Rx2

INT 4

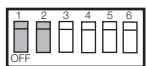

INT 4.1 } "ON", polarizes the
 INT 4.2 } reception channel Rx1

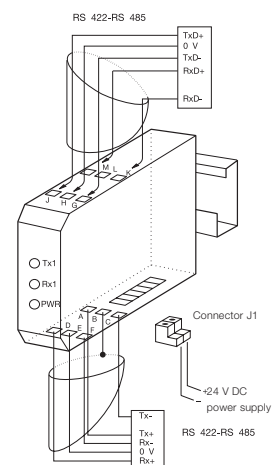
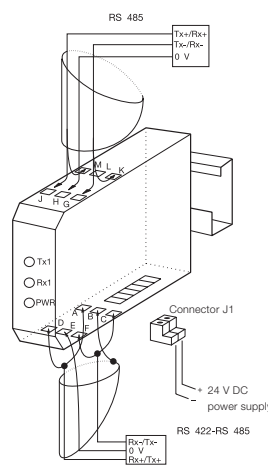

Caution :

The transmission channels of both RS 422 - RS 485 serial link interfaces always have to be independently polarized.

ADAPTING THE RS 422 - RS 485 CONNECTIONS

The connections must always be adjusted to the level of the reception channel of each subscriber forming the end of the bus. The ILPH is used to adjust the reception channel by setting the micro-switch INT 3.3 and INT 4.3.

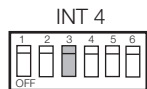
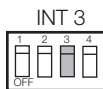

INT 3.3 and INT 4.3 "ON" 120 Ω set adjustment

BAUD RATE

By using the 8 micro-switches inside the box.

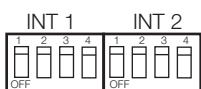

Permits to define up to 8 transmission speeds and to select the Full Duplex operation mode (RS 422 / RS 422) in addition with the INT 3.4 INT 4.4 and INT 4.5 micro switches.

Serial data converters

Connection diagrams, Jumper settings

ILPH RS 232 / RS 422 - 485 (electrical isolated)

4

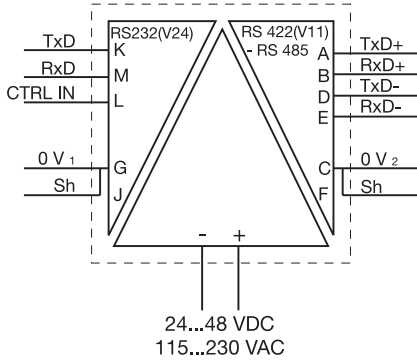

RS 422 - RS 485
2 WIRE SERIAL LINK

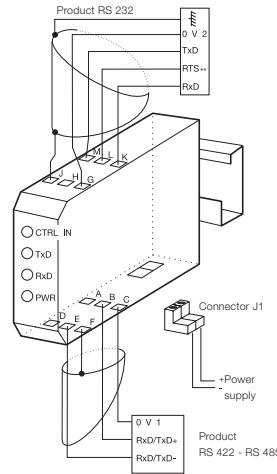

***CAUTION :**
When the RTS signal is not generated, set SW2-1 in position ON.

RS 422 - RS 485
4 WIRE SERIAL LINKS

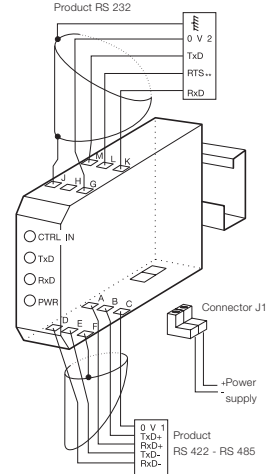

****CAUTION :**
Only to be connected for RS 485 two pairs (of no use for RS 422 two pairs).
If the RTS signal is not generated, set SW2-1 in position ON.

ILPH RS 232 / RS 232

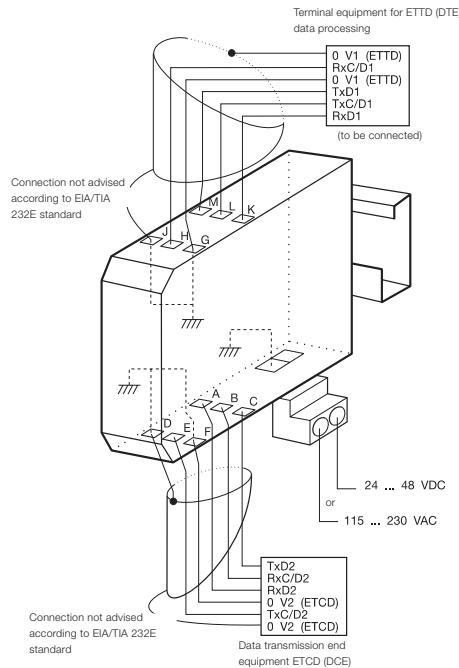
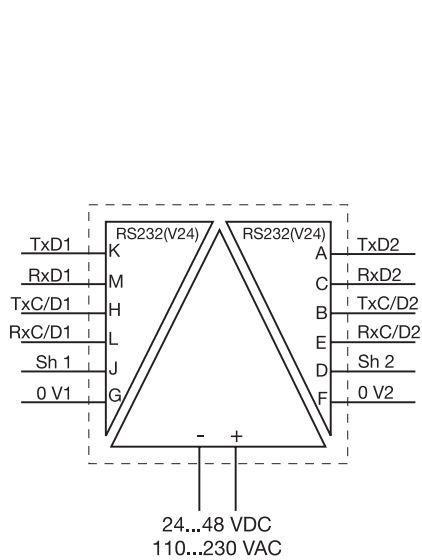

Serial data converters

Connection diagrams, Jumper settings

ILPH RS 232 / FO

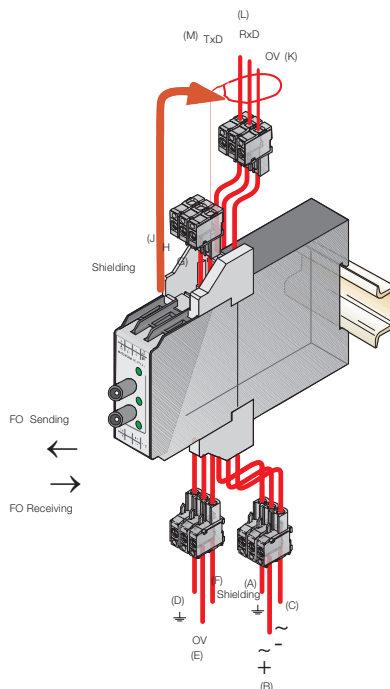
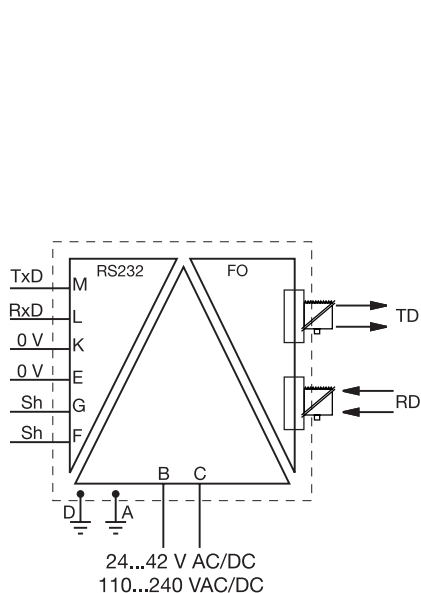

ILPH RS 485 / FO

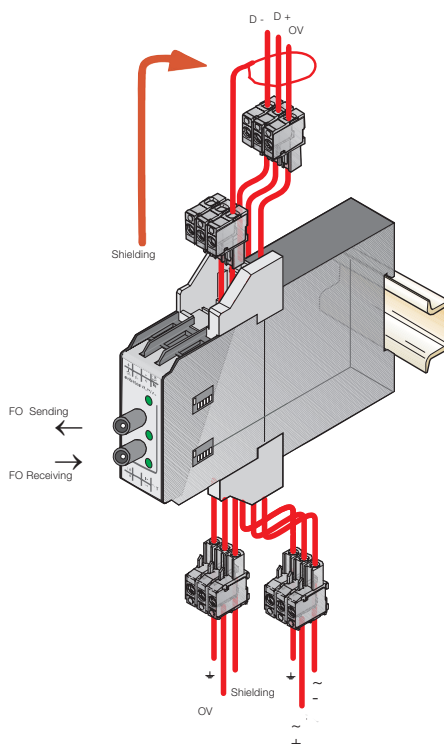
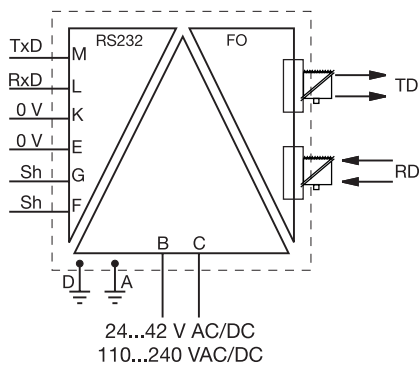

Serial data converters

Technical data

Technical data

Data at $T_a = 25\text{ °C}$ and rated values, unless otherwise indicated

		ILPH RS 232 - 485 / Ethernet
Power supply 1		
Voltage		10...34 V DC, 10...24 V AC
Voltage tolerance		-10%, +10%
Consumption		2 W max
Connections		coding screw removable connector 0 to 2.5 mm ² (22-14 AWG)
Power supply 2		
Voltage		10...34 V DC
Voltage tolerance		-10%, +10%
Consumption		2 W max
Connections		screw connector (AWG 20)
Serial link 1: RS 232		
		EIA RS 232
Overvoltage protection		integrated
Baud rate / Transmission distance		max. 115.2 kbits/s / max. 15 m
Connections		2.5 mm ² screw connector (AWG 20) or male SubD 9 points
Serial link 2: RS 485		
		EIA RS 485
Voltage		integrated
Line polarization		integrated
End line resistance		integrated
Baud rate / Transmission distance		max. 115.2 kbits/s / max. 1200 m
Connections		coding screw removable connector 0 to 2.5 mm ² (22-14 AWG)
Ethernet link		
Overvoltage protection		integrated
Baud rate / Transmission distance		10-100 Mbits/s / max. 100 m without Hub or Switch with CAT5 cable
Connections		RJ45 connector
Traffic indication		
Voltage		1 yellow LED
Status of signal		3 green LED (RxD, TxD, LINK), 2 amber or green LED (Speed, Activity)
EMC behavior		
Electrostatic discharge		EN 61000-4-2
Radiated electromagnetic field		EN 61000-4-3
Burst		EN 61000-4-4
Surge		EN 61000-4-5
Electromagnetic compatibility		EN 55022
Other characteristics		
Electrical isolation between serial link / power supply / Ethernet link		750 VDC / 1500 VAC
Configuration of the operating mode		using internal switches or/and software (TELNET or HYPERTERMINAL)
Operating temperature		0°C ... +60°C
Storage temperature		-20°C ... +70°C
Mounting		any required
DIN rail fixing (EN 50002)		snap-on mounting
Wire size		2.5 mm ² / stranded with ferrule, 4 mm ² solid
Dimensions (WxDxH)		94 x 22.5 x 100 mm
Weight		120 g

Serial data converters

Technical data

Technical data

Data at $T_a = 25\text{ °C}$ and rated values, unless otherwise indicated

ILPH RS 232 / RS 422 - 485 (without isolation)	
Power supply	polarized
Voltage	24 V DC
Voltage tolerance	8.5...28 V DC
Supply current	100 mA max
Connections	removable screw connectors (AWG 20)
Serial link 1: RS 232	EIA RS 232 C / CCITT V24 V28
Overvoltage protection	integrated (transil 8 kV 1.2/50 μ s)
Baud rate / Transmission distance	max. 38.4 kbits/s / max. 1200 m
Connections	2.5 mm ² screw connectors (AWG 20)
Serial link 2: RS 422-485	EIA RS 485 and EIA RS 422 / CCITT V11
Overvoltage protection	integrated (transil 8 kV 1.2/50 μ s)
Baud rate / Transmission distance	max. 38.4 kbits / max. 1200 m
Connections	2.5 mm ² screw connectors (AWG 20)
Traffic indication	
Voltage	1 yellow LED
Connections	2 green LED (Rx/D, Tx/D)
EMC behavior	
Electrostatic discharge	EN 61000-4-2 level 3 6/8 kV
Radiated electromagnetic field	EN 61000-4-3 level 310 V/m
Burst	EN 61000-4-4 level 3 1 kV
Electromagnetic compatibility	EN 55022 class B
Other characteristics	
Electrical isolation between serial link / power supply / Ethernet link	no
Configuration of the operating mode	using internal jumper
Operating temperature	0°C ... +50°C
Storage temperature	-25°C ... +80°C
Mounting	any required
DIN rail fixing (EN 50002)	snap-on mounting
Wire size	2.5 mm ² / stranded with ferrule, 4 mm ² solid
Dimensions (WxDxH)	88 x 22.5 x 100 mm
Weight	100 g

Serial data converters

Technical data

Technical data

Data at $T_a = 25\text{ °C}$ and rated values, unless otherwise indicated

	ILPH RS 232 / RS 422 - 485 (isolated)
Power supply	polarized
Voltage	24 V DC
Voltage tolerance	8.5...28 V DC
Supply current	100 mA max
Connections	Removable screw connectors (Omnicconnect)
Serial link 1: RS 232	EIA RS 232 C / CCITT V24 V28
Overvoltage protection	integrated (transil 8 kV 1.2/50µs)
Baud rate / Transmission distance	max. 38.4 kbits/s / max. 15 m
Connections	2.5 mm ² screw connectors (AWG 20)
Serial link 2: RS 422-485	EIA RS 485 and EIA RS 422 / CCITT V11
Overvoltage protection	integrated (transil 8 kV 1.2/50 µs)
Baud rate / Transmission distance	max. 38.4 kbits / max. 1200 m
Connections	2.5 mm ² screw connectors (AWG 20)
Traffic indication	
Voltage	1 yellow LED
Connections	3 green LED (RxD, TxD and CTRL-IN)
EMC behavior	
Electrostatic discharge	EN 61000-4-2 level 3 6/8 kV
Radiated electromagnetic field	EN 61000-4-3 level 310 V/m
Burst	EN 61000-4-4 level 3 1 kV
Electromagnetic compatibility	EN 55022 class B
Other characteristics	
Electrical isolation between serial link / power supply / Ethernet link	500 V DC
Configuration of the operating mode	using internal jumper
Operating temperature	0°C ... +50°C
Storage temperature	-25°C ... +80°C
Mounting	any required
DIN rail fixing (EN 50002)	snap-on mounting
Wire size	2.5 mm ² / stranded with ferrule, 4 mm ² solid
Dimensions (WxDxH)	88 x 22.5 x 100 mm
Weight	100 g

Serial data converters

Technical data

Technical data

Data at $T_a = 25\text{ °C}$ and rated values, unless otherwise indicated

ILPH RS 232 / RS 422 - 485 (3 way electrical isolated)	
Power supply	
Voltage	24...48 V DC
Voltage tolerance	-15% ... +20%
Supply current	24 V DC<110 mA, 48 V DC<55 mA, 115 V AC<40 mA, 230 V DC<26 mA
Supply power	~ 3 W
Connections	Removable screw connector (Omnicontact)
Serial link 1: RS 232	
Overvoltage protection	integrated (transil 8 kV 1.2/50 μ s)
Baud rate / Transmission distance	max. 19,2 kbits/s / max. 15 m / 2500 pF
Connections	2.5 mm ² screw (AWG 20)
Serial link 2: RS 422-485	
Overvoltage protection	integrated (transil 8 kV 1.2/50 μ s)
Baud rate / Transmission distance	max. 19,2 kbits/s / max. 15 m
Connections	2.5 mm ² screw (AWG 20)
Traffic indication	
Voltage	1 yellow LED
Connections	4 green LED (RxD, RxC/D, TxD, TxC/D)
EMC behavior	
Electrostatic discharge	EN 61000-4-2 level 3 6/8 kV
Radiated electromagnetic field	EN 61000-4-3 level 3 10 V/m
Burst	EN 61000-4-4 level 3 1 kV
Electromagnetic compatibility	EN 55022 class B
Other characteristics	
Electrical isolation between RS 232 / Power supply / RS 422-RS 485	1,5 kV
Configuration of the operating mode	No
Operating temperature	0°C ... +50°C
Storage temperature	-25°C ... +80°C
Mounting	any required
DIN rail fixing (EN 50002)	snap-on mounting
Wire size	2.5 mm ² / stranded with ferrule, 4 mm ² solid
Dimensions (WxDxH)	88 x 22,5 x 100 mm
Weight	100 g

Serial data converters

Technical data

Technical data

Data at $T_a = 25\text{ °C}$ and rated values, unless otherwise indicated

	ILPH RS 232 / RS 232	
Power supply	DC model polarized	
Voltage	24...48 V DC	115...230 V AC (50/60Hz)
Voltage tolerance	-15%...+20%	-15%...+15%
Supply current	24 V DC<155 mA;48 V DC<77 mA;110 V AC<40 mA;230 V DC<26 mA	
Supply power	~ 3.15 W	
Connections	Removable screw connector (Omniconnect)	
Interface 1: RS 232	EIA / TIA RS 232 new revision / CCITT V24 V28	
Overvoltage protection	integrated (transil 8 kV 1.2/50 μ s)	
Transmission capacity / Transmission distance	max. 19.2 kbits/s / max. 15 m / 2500 pF	
Connections	2.5 mm ² screw (AWG 20)	
Interface 2: RS 232	EIA / TIA RS 232 new revision / CCITT V24 V28	
Overvoltage protection	integrated (transil 8 kV 1.2/50 μ s)	
Transmission capacity / Transmission distance	max. 19.2 kbits/s / max. 15 m	
Connections	2.5 mm ² screw (AWG 20)	
Traffic indication		
Voltage	1 yellow LED	
Connections	4 green LED (Rx/D, Rx/C/D, Tx/D, Tx/C/D)	
EMC behavior		
Electrostatic discharge	EN 61000-4-2 level 3 6/8 kV	
Radiated electromagnetic field	EN 61000-4-3 level 3 10 V/m	
Burst	EN 61000-4-4 level 3 1 kV	
Electromagnetic compatibility	EN 55022 class B	
Other characteristics		
Electrical isolation between serial link / power supply / Ethernet link	1.5 kV	
Configuration of the operating mode	No	
Operating temperature	0°C ... +50°C	
Storage temperature	-25°C ... +80°C	
Mounting	any required	
DIN rail fixing (EN 50002)	snap-on mounting	
Wire size	2.5 mm ² / stranded with ferrule, 4 mm ² solid	
Dimensions (WxDxH)	88 x 22.5 x 100 mm	
Weight	100 g	

Serial data converters

Technical data

Technical data

Data at $T_a = 25\text{ °C}$ and rated values, unless otherwise indicated

ILPH RS 422 - 485 / RS 422 - 485	
Power supply	
Voltage	DC model polarized
Voltage tolerance	24 V DC
Supply current	+/-15%
Connections	120 mA max.
Interface 1: RS 422-485	
Overvoltage protection	Removable screw connector (Omniconnect)
RS 485 data switching	EIA / RS 485 and EIA RS 422 / CCITT V11
Baud rate / Transmission distance	integrated (transil 8 kV 1.2/50 μ s)
Connections	Time switching / Time delay transmission/reception 27 μ s ...10 ms
Interface 2: RS 422-485	
Overvoltage protection	EIA / RS 485 and EIA RS 422 / CCITT V11
RS 485 data switching	integrated (transil 8 kV 1.2/50 μ s)
Baud rate / Transmission distance	Time switching / Time delay transmission/reception 27 μ s ...10 ms
Connections	from 1.2 to 500 kbits/s / max. 1200 m up to 38.4 kbit/s
Traffic indication	
Voltage	2.5 mm ² screw (AWG 20)
Connections	EIA / RS 485 and EIA RS 422 / CCITT V11
EMC behavior	
Electrostatic discharge	integrated (transil 8 kV 1.2/50 μ s)
Radiated electromagnetic field	Time switching / Time delay transmission/reception 27 μ s ...10 ms
Burst	from 1.2 to 500 kbits/s / max. 1200 m up to 38.4 kbit/s
Electromagnetic compatibility	2.5 mm ² screw (AWG 20)
Other characteristics	
Electrical isolation between RS 232 / Power supply / RSS 422-RS 485	1 yellow LED
Configuration of the operating mode	2 green LED (Rx, Tx,)
Operating temperature	EN 61000-4-2 level 3 6/8 kV
Storage temperature	EN 61000-4-3 level 3 10 V/m
Mounting	EN 61000-4-4 level 3 1 kV
DIN rail fixing (EN 50002)	EN 55022 class B
Wire size	500 V DC
Dimensions (WxDxH)	using internal DIP switches
Weight	0°C ... +50°C
	-25°C ... +80°C
	any required
	snap-on mounting
	2.5 mm ² / stranded with ferrule, 4 mm ² solid
	88 x 22.5 x 100 mm
	100 g

Serial data converters

Technical data

Technical data

Data at $T_a = 25^\circ\text{C}$ and rated values, unless otherwise indicated

		ILPH RS 232 / FO	
Power supplies			
Supply voltage	24...42 V AC/DC (50/60 Hz)	110...240 V AC/DC (50/60 Hz)	
Voltage tolerance	-15% ... +10%	-15% ... +10%	
Connections	Omniconnect pluggable connector		
Interface 1: RS 232			
Protection	Integrated (transil 8 kV 1.2/50 μ s)		
Max. speed / max. distance	Max. 115.2 kbits/s / max. 15 m / 2500 pF		
Connections	Omniconnect pluggable connector		
Fiber optic interface 2			
	DIN VDE 0888-1		
Type of fiber / Connections	Multimode fiber Glass : ST connector; Plastic : FSMA screw connector		
Wave length	Glass : 820 nm; Plastic : 655 nm		
Max. transmission power	Glass : 50/125 μ m : -14.4 db/m; Glass : 62.5/125 μ m : -14 db/m; Plastic : 980/1000 μ m : -8 db/m		
Max. reception power	Glass : -28 db/m; Plastic : -20 db/m		
Max. speed	Max. 115.2 kbits/s		
Max. distance	Glass : 50/125 μ m : 3 km; Glass : 62.5/125 μ m : 4 km; Plastic : 980/1000 μ m : 40 m		
Status indication			
Power supply / Data exchange	1 green LED / 2 green LEDs (Rx/D, Tx/D)		
EMC behavior			
Electrostatic discharge	EN 61000-4-2 Level 3 6/8 kV		
Radiated electromagnetic field	EN 61000-4-3 Level 3 10 V/m		
Burst	EN 61000-4-4 Level 3 1 kV		
Electromagnetic compatibility	EN 55022 Class B		
Other characteristics			
Electrical isolation input / power supply / output	2.5 kV		
Operating temperature	-20°C ... +60°C		
Storage temperature	-40°C ... +85°C		
Mounting	Onto DIN Rail (EN 50002)		
Connections	14 AWG (2.5 mm ²) fine stranded / 12 AWG (4 mm ²) rigid		
Dimensions (WxDxH)	105 x 22.5 x 112 mm / 4.13 x 0.89 x 4.41"		
Weight	150 g / 0.33 lb		

Serial data converters

Technical data

Technical data

Data at $T_a = 25\text{ }^\circ\text{C}$ and rated values, unless otherwise indicated

		ILPH RS 485 / FO
Power supplies		
Supply voltage	24...42 V AC/DC (50/60 Hz)	110...240 V AC/DC (50/60 Hz)
Voltage tolerance	-15% ... +10%	-15% ... +10%
Connections	Omnicconnect pluggable connector	
Interface 1: RS 232		
Protection	ISO / IEC 8482 / DIN 66 259-4; EIA 485	
Max. speed / max. distance	Integrated (transil 8 kV 1.2/50 μ s)	
Connections	Max. 1.5 Mbits/s / max. 1200 m (38.4 kbit/s)	
Fiber optic interface 2		
Type of fiber / Connections	DIN VDE 0888-1	
Wave length	Multimode fiber	
Max. transmission power	Glass : ST connector; Plastic : FSMA screw connector	
Max. reception power	Glass : 820 nm; Plastic : 655 nm	
Max. speed	Glass : 50/125 μ m : -14.4 db/m; Glass : 62.5/125 μ m : -14 db/m; Plastic : 980/1000 μ m : -8 db/m	
Max. distance	Glass : -28 db/m; Plastic : -20 db/m	
Status indication		
Power supply / Data exchange	1 green LED / 2 green LEDs (Rx/D, Tx/D)	
EMC behavior		
Electrostatic discharge	EN 61000-4-2 Level 3 6/8 kV	
Radiated electromagnetic field	EN 61000-4-3 Level 3 10 V/m	
Burst	EN 61000-4-4 Level 3 1 kV	
Electromagnetic compatibility	EN 55022 Class B	
Other characteristics		
Electrical isolation input / power supply / output	2.5 kV	
Operating temperature	-20 $^\circ$ C ... +60 $^\circ$ C	
Storage temperature	-40 $^\circ$ C ... +85 $^\circ$ C	
Mounting	Onto DIN Rail	
Connections	14 AWG (2.5mm 2) / fine stranded, 12 AWG (4 mm 2) rigid	
Dimensions (WxDxH)	105 x 22.5 x 112 mm / 4.13 x 0.89 x 4.41"	
Weight	150 g / 0.33 lb	

Serial data converters

Technical data

Technical data

Data at $T_a = 25\text{ °C}$ and rated values, unless otherwise indicated

	ILPH RS 422 - 485 (for current loop)
Power supply	DC model polarized
Voltage	24 V DC
Voltage tolerance	+/-10%
Supply current	120 mA max.
Connections	Removable screw connector (Omnicontact)
Interface 1: Current loop	active/passive 0...20 mA / 4...20 mA, mode is settable
Logic level	0 = 20 mA or 1 = 20 mA, settable
Baud rate / Transmission distance	max. 38.4 kbit/s / max. 1200 m
Connections	2.5 mm ² screw (AWG 20)
Serial link 2: RS 422/485	EIA RS 485 and EIA RS 422 / CCITT V 11
Overvoltage protection	integrated (transil 8 kV 1.2/50 µs)
Baud rate / Transmission distance	max. 38.4 kbit/s / max. 1200 m
Connections	2.5 mm ² screw (AWG 20)
Traffic indication	
Voltage	1 yellow LED
Status of signal	2 green LED (Rx/D, Tx/D)
EMC behavior	
Electrostatic discharge	EN 61000-4-2 level 2 4/4 kV
Radiated electromagnetic field	EN 61000-4-3 level 3 10 V/m
Burst	EN 61000-4-4 level 1 0.5 kV
Electromagnetic compatibility	EN 55022 class B
Other characteristics	
Electrical isolation between input / output and power supply / output	depending on Current Loop (active/passive); 500 V DC (active) / 2000 V DC (passive)
RS 422-485 power supply	500 V DC
Configuration of the operating mode	using internal DIP switches
Operating temperature	0°C ... +50°C
Storage temperature	-25°C ... +80°C
Mounting	any required
DIN rail fixing (EN 50002)	snap-on mounting
Wire size	2.5 mm ² / stranded with ferrule, 4 mm ² solid
Dimensions (WxDxH)	88 x 22.5 x 100 mm
Weight	100 g

Serial data converters

Technical data

Technical data

Data at $T_a = 25\text{ °C}$ and rated values, unless otherwise indicated

ILPH RS 232 / CL	
Power supply	DC model polarized
Voltage	24 V DC
Voltage tolerance	+/-10%
Supply current	120 mA max.
Connections	Removable screw connector (Omniconnect)
Serial link 2: RS 232	EIA RS 232 C / CCITT V 24 V 28
Logic level	integrated (transil 8 kV 1.2/50 μ s)
Baud rate / Transmission distance	max. 38.4 kbit/s / max. 15 m
Connections	2.5 mm ² screw (AWG 20)
BdC serial link 2: RS 422/485	active/passive 0...20 mA / 4...20 mA mode settable
Overvoltage protection	0=20 mA or 1=20 mA settable
Baud rate / Transmission distance	max. 38.4 kbit/s / max. 1200 m
Connections	2.5 mm ² screw (AWG 20)
Traffic indication	
Voltage	1 yellow LED
Status signal	2 green LED (Rx/D, Tx/D)
EMC behavior	
Electrostatic discharge	EN 61000-4-2 level 3 6/8 kV
Radiated electromagnetic field	EN 61000-4-3 level 3 10 V/m
Burst	EN 61000-4-4 level 3 1 kV
Electromagnetic compatibility	EN 55022 class B
Other characteristics	
Electrical isolation between Current loop / RS 232	depending on current loop (active/passive) 500 V DC (active) / 2000 V DC (passive)
Electrical isolation between Current loop / power supply	500 V DC (active) / 2000 V DC (passive)
Configuration of the operating mode	using internal DIP switches
Operating temperature	0°C ... +50°C
Storage temperature	-25°C ... +80°C
Mounting	any required
DIN rail fixing (EN 50002)	snap-on mounting
Wire size	2.5 mm ² / stranded with ferrule, 4 mm ² solid
Dimensions (WxDxH)	88 x 22.5 x 100 mm
Weight	100 g

Serial data converters

Dimensional drawings

ILPH RS 232 - 485 Ethernet

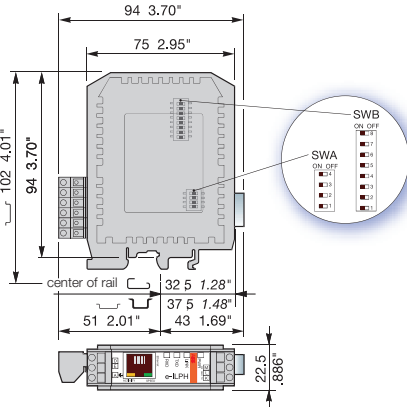

ILPH RS 232 / RS 232
 ILPH RS 232 - 485 Ethernet
 ILPH CL / RS 422 - 485
 ILPH RS 232 - 485 Ethernet
 ILPH RS 422 - 485 / RS 422 / - 485

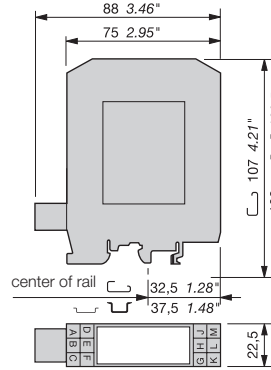

ILPH RS 232 / FO and ILPH RS 485 / FO

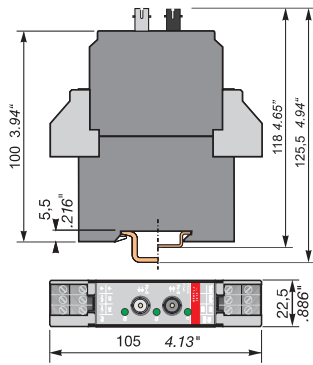

ILPH RS 232 / CL

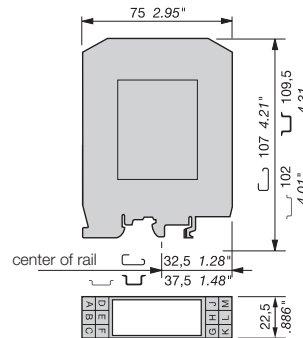

Serial data converters

Notes

A series of horizontal dotted lines spanning the width of the page, intended for taking notes.

Interface relays and optocouplers

Product group picture

5

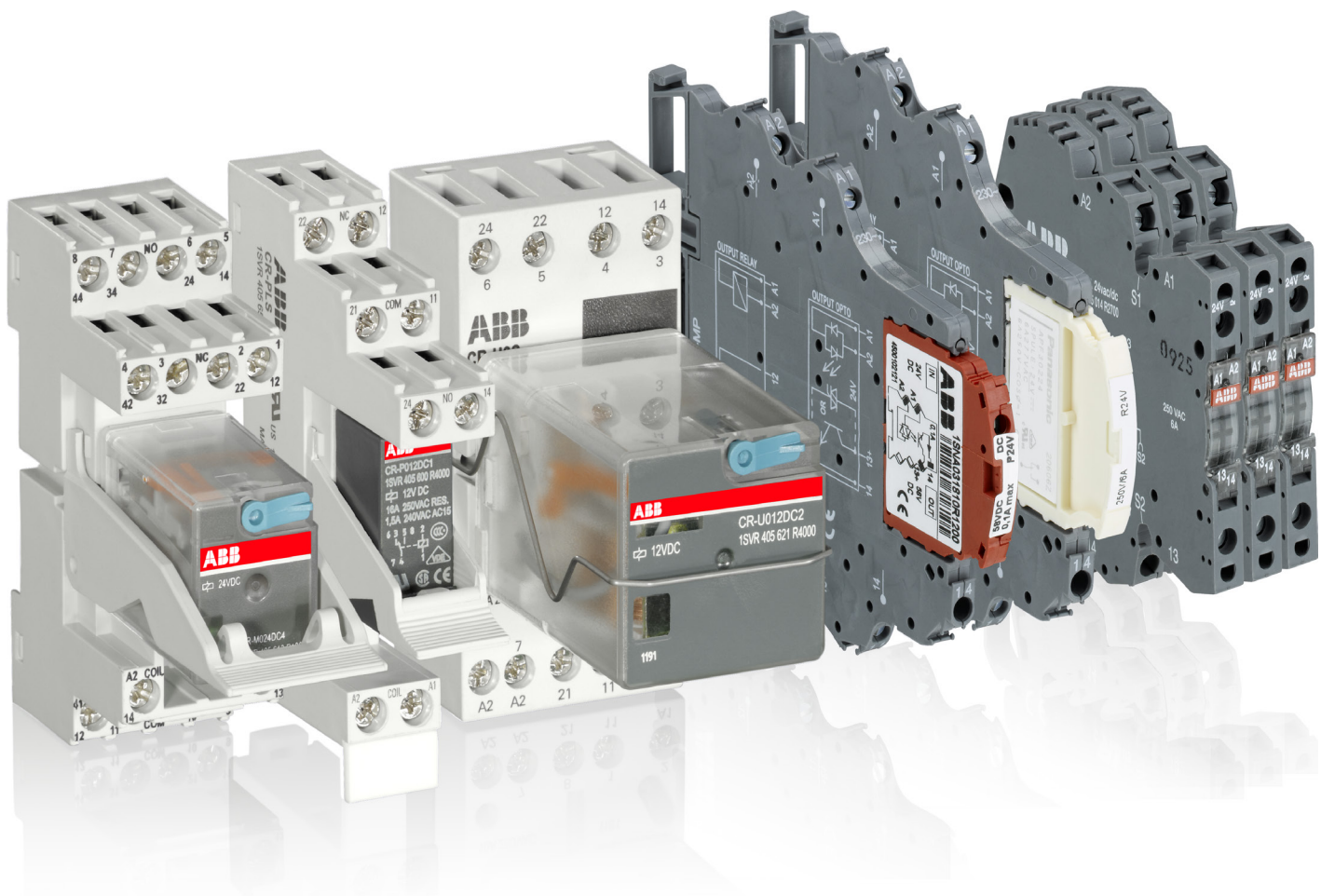

Interface relays and optocouplers

Table of contents

Interface Relays and Optocouplers	
Pluggable interface relays	5/3
Table of contents	5/4
Benefits and advantages	5/5
Approvals and marks	5/6
Ordering details	5/7
Technical data	5/14
Technical data, Load limit curves	5/16
Load limit curves	5/17
Connection diagrams	5/18
Interface relays and optocouplers R500 / R600 range	5/21
Table of contents	5/22
Benefits and advantages	5/23
Type designators	5/24
Interface relays and optocouplers R500 range	5/25
Table of contents	5/26
Interface relays R500 range	5/27
Table of contents	5/28
Selection	5/29
Ordering details	5/30
Technical information	5/31
Optocouplers R500 range	5/33
Table of contents	5/34
Selection	5/35
Ordering details	5/36
Connection diagrams	5/37
Technical data	5/38
Interface relays and optocouplers R600 range	5/45
Table of contents	5/46
Interface relays R600 range	5/47
Table of contents	5/48
Benefits and advantages	5/49
Selection	5/51
Ordering details	5/53
Connection diagrams	5/55
Technical data	5/56
General technical data	5/61
Dimensional drawings, Load limit curves	5/62
Optocouplers R600 range	5/63
Table of contents	5/64
Selection	5/65
Ordering details	5/67
Connection diagrams	5/68
Technical data	5/69

Pluggable interface relays

Product group picture

5

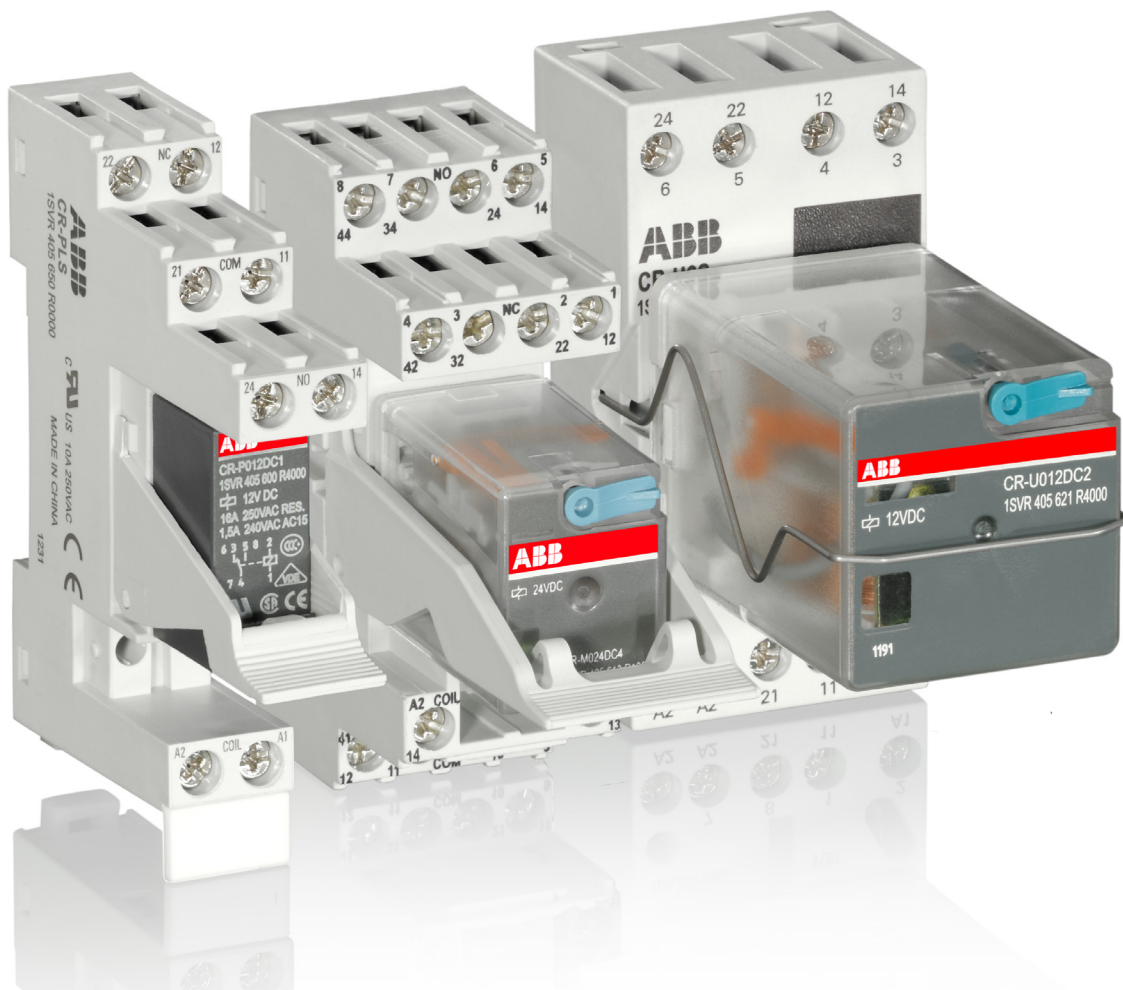

Pluggable interface relays

Table of contents

Pluggable interface relays	
Product group picture	5/3
Table of contents	5/4
Benefits and advantages	5/5
Approvals and marks	5/6
Ordering details	5/7
Technical data	5/14
Technical data, Load limit curves	5/16
Load limit curves	5/17
Connection diagrams	5/18

Pluggable interface relays

Benefits and advantages

Pluggable pcb relays CR-P

- 9 different coil voltages
 - DC versions: 12 V, 24 V, 48 V, 110 V
 - AC versions: 24 V, 48 V, 110 V, 120 V, 230 V
- Output contacts:
 - 1 c/o contact (16 A) or
 - 2 c/o contacts (8 A) optionally equipped with gold contacts
- Logical or standard sockets
- Cadmium-free contact material
- Width of socket: 15,5 mm
- Pluggable function modules
 - Reverse polarity protection/ Free wheeling diode
 - LED indication
 - RC elements
 - Overvoltage protection

Pluggable miniature relays CR-M

- 12 different coil voltages
 - DC versions: 12 V, 24 V, 48 V, 60 V, 110 V, 125 V, 220 V
 - AC versions: 24 V, 48 V, 110 V, 120 V, 230 V
- Output contacts
 - 2 c/o contacts (12 A) or
 - 3 c/o contacts (10 A) or
 - 4 c/o contacts (6 A) optionally equipped with gold contacts, LED and free wheeling diode
- Integrated test button for manual actuation and locking of the output contacts (blue = DC, orange = AC) that can be removed if necessary
- With or without integrated LED
- Logical or standard sockets
- Cadmium-free contact material
- Width on socket: 27 mm
- Pluggable function modules
 - Reverse polarity protection/ Free wheeling diode
 - LED indication
 - RC elements
 - Overvoltage protection

Pluggable universal relays CR-U

- 12 different coil voltages
 - DC versions: 12 V, 24 V, 48 V, 110 V, 125 V, 220 V
 - AC versions: 24 V, 48 V, 60 V, 110 V, 120 V, 230 V
- Output contacts
 - 2 c/o contacts (10 A) or
 - 3 c/o contacts (10 A)
- Integrated test button for manual actuation and locking of the output contacts (blue = DC, orange = AC) that can be removed if necessary
- With or without integrated LED
- Cadmium-free contact material
- Width on socket: 38 mm
- Pluggable function modules
 - Reverse polarity protection/ Free wheeling diode
 - LED indication
 - RC elements
 - Overvoltage protection
 - Multifunction time module

5

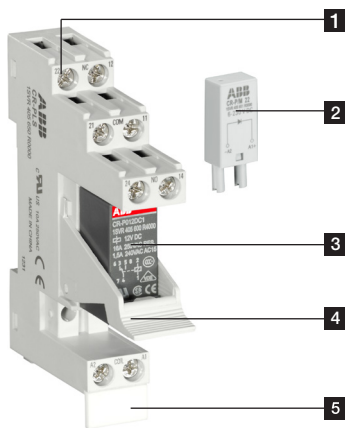

- 1** Socket
- 2** Pluggable function module
- 3** Interface relay
- 4** Holder
- 5** Marker label

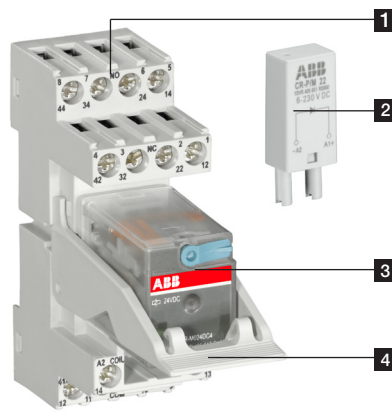

- 1** Socket
- 2** Pluggable function module
- 3** Interface relay
- 4** Holder



- 1** Socket
- 2** Pluggable function module
- 3** Interface relay
- 4** Holder

Pluggable interface relays

Approvals and marks

Kinds of sockets

Standard sockets - Position of connecting terminals:

Coil connection (A1-A2) on lower socket side, contact connections (n/o and n/c contacts) on the lower and upper socket side.

Logical sockets - Position of connecting terminals:

Coil connection (A1-A2) on lower socket side, all contact connections (common contacts, n/o and n/c contacts) on upper socket side.

Details see connection diagrams

Kind of connecting terminals

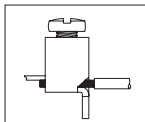

Screw type

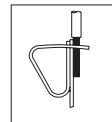

Spring type

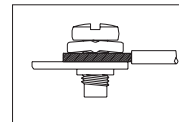

Fork type

Approvals and marks

		Relays			Sockets							Modules	
		CR-P	CR-M	CR-U	CR-PLS CR-PSS	CR-PLC	CR-M..L. CR-M..SS	CR-M..SF	CR-U..S CR-U..E	CR-U..SM	CR-P/M	CR-U	
■ existing	□ pending												
Approvals													
	UL 508	■	■ ¹⁾	■									
	CAN/CSA C22.2 No.14	■	■ ²⁾	■	■	■	■	■	■	■	■ ⁶⁾	■ ⁷⁾	
	CAN/CSA C22.2 No.14	■	■ ³⁾	■									
	VDE	■	■ ⁴⁾	■									
	GOST	■	■	■	■	■	■	■	■	■	■	■	■
	Lloyds Register		■ ⁵⁾	■									
	CCC	■	■	■									
	RMRS	■	■ ⁸⁾	■ ⁸⁾	■	■	■	■	■	■			
Marks													
	CE	■	■	■	■	■	■	■	■	■	■	■	■

¹⁾ except 60 V DC and 125 V DC devices with gold contacts

²⁾ except devices with gold contacts

³⁾ except 60 V DC and 125 V DC devices

⁴⁾ except 125 V DC devices

⁵⁾ only devices with 4 c/o contacts

⁶⁾ except CR-P/M 42B, CR-P/M 42BV, CR-P/M 42C, CR-P/M 42CV, CR-P/M 52D, CR-P/M 62E, CR-P/M 62EV, CR-P/M 62D, CR-P/M 62DV

⁷⁾ except CR-U 41B, CR-U 41BV, CR-U 41C, CR-U 41CV, CR-U 51D, CR-U 61CV, CR-U 61E, CR-U 61EV, CR-U 61D, CR-U 61DV, CR-U 91C, CR-U T

⁸⁾ except 60 V and 125 V devices

Pluggable interface relays

Ordering details



CR-P

2CDC 291 045 F0004

Description

Interface relays are widely used in various industrial applications:

As an interface they link the electronic controlling, e.g. PLC (programmable logic controller), PC or field bus systems, to the sensor / actuator level. Here, they take on various functions: Switching of AC or DC loads with different resistive, inductive and capacitive parts, switching voltages from a few mV up to 250 V, switching currents from a few mA up to 16 A, amplification of weak control signals, electrical isolation of control and load circuits, and signal multiplying. In contrast to electronic switching devices, interface relays don't use additional internal protective circuits and thus are overload-proof against short-time variations like current or voltage peaks.

Ordering details - CR-P range

Rated control supply voltage	Outputs	Contact ratings	Type	Order code	Price	Pkg qty	Weight (1 pce)
							kg (lb)
12 V DC	1 c/o (SPDT)	250 V, 16 A	CR-P012DC1	1SVR405600R4000		10	0.014 (0.031)
24 V DC			CR-P024DC1	1SVR405600R1000			
48 V DC			CR-P048DC1	1SVR405600R6000			
110 V DC			CR-P110DC1	1SVR405600R8000			
24 V AC			CR-P024AC1	1SVR405600R0000			
48 V AC			CR-P048AC1	1SVR405600R5000			
110 V AC			CR-P110AC1	1SVR405600R7000			
120 V AC			CR-P120AC1	1SVR405600R2000			
230 V AC			CR-P230AC1	1SVR405600R3000			
12 V DC	2 c/o (SPDT)	250 V, 8 A	CR-P012DC2	1SVR405601R4000		10	0.014 (0.031)
24 V DC			CR-P024DC2	1SVR405601R1000			
48 V DC			CR-P048DC2	1SVR405601R6000			
110 V DC			CR-P110DC2	1SVR405601R8000			
24 V AC			CR-P024AC2	1SVR405601R0000			
48 V AC			CR-P048AC2	1SVR405601R5000			
110 V AC			CR-P110AC2	1SVR405601R7000			
120 V AC			CR-P120AC2	1SVR405601R2000			
230 V AC			CR-P230AC2	1SVR405601R3000			
24 V DC	2 c/o (SPDT) gold contact	250 V, 8 A	CR-P024DC2G	1SVR405606R1000		10	0.014 (0.031)
24 V AC			CR-P024AC2G	1SVR405606R0000			
110 V AC			CR-P110AC2G	1SVR405606R7000			
230 V AC			CR-P230AC2G	1SVR405606R3000			



CR-PLS

2CDC 291 006 F0011

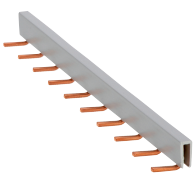

CR-PJ

2CDC 291 004 F0007

Ordering details - Accessories

Version	Connection terminal	Type	Order code	Price	Pkg qty	Weight (1 pce)
						kg (lb)
Logical socket with protective separation	screw	CR-PLS	1SVR405650R0000		10	0.045 (0.099)
		CR-PLSx	1SVR405650R0100			0.043 (0.095)
Logical socket	spring	CR-PLC	1SVR405650R0200		10	0.042 (0.093)
	screw	CR-PSS	1SVR405650R1000			0.038 (0.084)
Standard socket	screw	CR-PH	1SVR405659R0000		10	0.002 (0.004)
Plastic holder for socket		CR-PJ	1SVR405658R5000			0.018 (0.040)
Jumper bar for sockets with screw connection		CR-PM	1SVR405658R0000		10	0.0002 (0.0004)
Marker						

Bold printed products = stocked products

Pluggable interface relays

Ordering details



CR-M

2CDC 291 046 F0004

Description

Interface relays are widely used in various industrial applications:

As an interface they link the electronic controlling, e.g. PLC (programmable logic controller), PC or field bus systems, to the sensor / actuator level. Here, they take on various functions: Switching of AC or DC loads with different resistive, inductive and capacitive parts, switching voltages from a few mV up to 250 V, switching currents from a few mA up to 16 A, amplification of weak control signals, electrical isolation of control and load circuits, and signal multiplying. In contrast to electronic switching devices, interface relays don't use additional internal protective circuits and thus are overload-proof against short-time variations like current or voltage peaks.

Ordering details - CR-M range without LED

Rated control supply voltage	Outputs	Contact ratings	Type	Order code	Price	Pkg qty	Weight (1 pce) kg (lb)				
12 V DC	2 c/o (SPDT)	250 V, 12 A	CR-M012DC2	1SVR405611R4000		10	0.033 (0.073)				
24 V DC			CR-M024DC2	1SVR405611R1000							
48 V DC			CR-M048DC2	1SVR405611R6000							
60 V DC			CR-M060DC2	1SVR405611R4200							
110 V DC			CR-M110DC2	1SVR405611R8000							
125 V DC			CR-M125DC2	1SVR405611R8200							
220 V DC			CR-M220DC2	1SVR405611R9000							
24 V AC			CR-M024AC2	1SVR405611R0000							
48 V AC			CR-M048AC2	1SVR405611R5000							
110 V AC			CR-M110AC2	1SVR405611R7000							
120 V AC			CR-M120AC2	1SVR405611R2000							
230 V AC			CR-M230AC2	1SVR405611R3000							
12 V DC			3 c/o (SPDT)	250 V, 10 A	CR-M012DC3			1SVR405612R4000		10	0.033 (0.073)
24 V DC					CR-M024DC3			1SVR405612R1000			
48 V DC	CR-M048DC3	1SVR405612R6000									
60 V DC	CR-M060DC3	1SVR405612R4200									
110 V DC	CR-M110DC3	1SVR405612R8000									
125 V DC	CR-M125DC3	1SVR405612R8200									
220 V DC	CR-M220DC3	1SVR405612R9000									
24 V AC	CR-M024AC3	1SVR405612R0000									
48 V AC	CR-M048AC3	1SVR405612R5000									
60 V AC	CR-M060AC3	1SVR405612R5200									
110 V AC	CR-M110AC3	1SVR405612R7000									
120 V AC	CR-M120AC3	1SVR405612R2000									
230 V AC	CR-M230AC3	1SVR405612R3000									
12 V DC	4 c/o (SPDT)	250 V, 6 A			CR-M012DC4	1SVR405613R4000		10	0.033 (0.073)		
24 V DC			CR-M024DC4	1SVR405613R1000							
48 V DC			CR-M048DC4	1SVR405613R6000							
60 V DC			CR-M060DC4	1SVR405613R4200							
110 V DC			CR-M110DC4	1SVR405613R8000							
125 V DC			CR-M125DC4	1SVR405613R8200							
220 V DC			CR-M220DC4	1SVR405613R9000							
24 V AC			CR-M024AC4	1SVR405613R0000							
48 V AC			CR-M048AC4	1SVR405613R5000							
110 V AC			CR-M110AC4	1SVR405613R7000							
120 V AC			CR-M120AC4	1SVR405613R2000							
230 V AC			CR-M230AC4	1SVR405613R3000							

Bold printed products = stocked products

Pluggable interface relays

Ordering details



CR-M

2CDC 291 046 F0004

Ordering details - CR-M range

Rated control supply voltage	Outputs	Contact ratings	Type	Order code	Price	Pkg qty	Weight (1 pce)				
							kg (lb)				
12 V DC	2 c/o (SPDT) with LED	250 V, 12 A	CR-M012DC2L	1SVR405611R4100		10	0.033 (0.073)				
24 V DC			CR-M024DC2L	1SVR405611R1100							
48 V DC			CR-M048DC2L	1SVR405611R6100							
60 V DC			CR-M060DC2L	1SVR405611R4300							
110 V DC			CR-M110DC2L	1SVR405611R8100							
125 V DC			CR-M125DC2L	1SVR405611R8300							
220 V DC			CR-M220DC2L	1SVR405611R9100							
24 V AC			CR-M024AC2L	1SVR405611R0100							
48 V AC			CR-M048AC2L	1SVR405611R5100							
110 V AC			CR-M110AC2L	1SVR405611R7100							
120 V AC			CR-M120AC2L	1SVR405611R2100							
230 V AC			CR-M230AC2L	1SVR405611R3100							
12 V DC			3 c/o (SPDT) with LED	250 V, 10 A	CR-M012DC3L			1SVR405612R4100		10	0.033 (0.073)
24 V DC					CR-M024DC3L			1SVR405612R1100			
48 V DC	CR-M048DC3L	1SVR405612R6100									
60 V DC	CR-M060DC3L	1SVR405612R4300									
110 V DC	CR-M110DC3L	1SVR405612R8100									
125 V DC	CR-M125DC3L	1SVR405612R8300									
220 V DC	CR-M220DC3L	1SVR405612R9100									
24 V AC	CR-M024AC3L	1SVR405612R0100									
48 V AC	CR-M048AC3L	1SVR405612R5100									
110 V AC	CR-M110AC3L	1SVR405612R7100									
120 V AC	CR-M120AC3L	1SVR405612R2100									
230 V AC	CR-M230AC3L	1SVR405612R3100									
12 V DC	4 c/o (SPDT) with LED	250 V, 6 A			CR-M012DC4L	1SVR405613R4100		10	0.033 (0.073)		
24 V DC					CR-M024DC4L	1SVR405613R1100					
48 V DC			CR-M048DC4L	1SVR405613R6100							
60 V DC			CR-M060DC4L	1SVR405613R4300							
110 V DC			CR-M110DC4L	1SVR405613R8100							
125 V DC			CR-M125DC4L	1SVR405613R8300							
220 V DC			CR-M220DC4L	1SVR405613R9100							
24 V AC			CR-M024AC4L	1SVR405613R0100							
48 V AC			CR-M048AC4L	1SVR405613R5100							
110 V AC			CR-M110AC4L	1SVR405613R7100							
120 V AC			CR-M120AC4L	1SVR405613R2100							
230 V AC2			CR-M230AC4L	1SVR405613R3100							
24 V DC			4 c/o (SPDT), LED and free-wheeling diode	250 V, 6 A	CR-M024DC4LD	1SVR405614R1100				10	0.033 (0.073)
24 V DC			4 c/o (SPDT), gold contacts	250 V, 6 A	CR-M024DC4G	1SVR405618R1000				10	0.033 (0.073)
24 V AC	CR-M024AC4G	1SVR405618R0000									
110 V AC	CR-M110AC4G	1SVR405618R7000									
230 V AC	CR-M230AC4G	1SVR405618R3000									

Bold printed products = stocked products

Pluggable interface relays

Ordering details



CR-M

2CDC 291 046 F0004

Rated control supply voltage	Outputs	Contact ratings	Type	Order code	Price	Pkg	Weight
						qty	(1 pce) kg (lb)
12 V DC	4 c/o (SPDT) with gold contacts and LED	250 V / 6 A	CR-M012DC4LG	1SVR405618R4100		10	0.033 (0.073)
24 V DC			CR-M024DC4LG	1SVR405618R1100			
48 V DC			CR-M048DC4LG	1SVR405618R6100			
60 V DC			CR-M060DC4LG	1SVR405618R4300			
110 V DC			CR-M110DC4LG	1SVR405618R8100			
125 V DC			CR-M125DC4LG	1SVR405618R8300			
220 V DC			CR-M220DC4LG	1SVR405618R9100			
24 V AC			CR-M024AC4LG	1SVR405618R0100			
48 V AC			CR-M048AC4LG	1SVR405618R5100			
110 V AC			CR-M110AC4LG	1SVR405618R7100			
120 V AC	CR-M120AC4LG	1SVR405618R2100					
230 V AC	CR-M230AC4LG	1SVR405618R3100					
12 V DC	4 c/o (SPDT) with gold contacts, LED and free-wheeling diode		CR-M012DC4LDG	1SVR405618R4400		10	0.033 (0.073)
24 V DC			CR-M024DC4LDG	1SVR405618R1400			

5



CR-M4SS

2CDC 291 009 F0011



CR-MJ

Ordering details - Accessories

Version	Connection terminal	Type	Order code	Price	Pkg	Weight
					qty	(1 pce) kg (lb)
Logical socket for 2 c/o	screw	CR-M2LS	1SVR405651R1100		10	0.055 (0.121)
Logical socket for 3 c/o		CR-M3LS	1SVR405651R2100			0.062 (0.137)
Logical socket for 2/4 c/o		CR-M4LS	1SVR405651R3100			0.066 (0.146)
Logical socket for 2 c/o	spring	CR-M2LC	1SVR405651R1200		10	0.065 (0.143)
Logical socket for 2/4 c/o		CR-M4LC	1SVR405651R3200			0.066 (0.146)
Standard socket for 2 c/o	screw	CR-M2SS	1SVR405651R1000		10	0.066 (0.146)
Standard socket for 3 c/o		CR-M3SS	1SVR405651R2000			0.068 (0.150)
Standard socket for 2/4 c/o		CR-M4SS	1SVR405651R3000			0.070 (0.154)
Standard socket for 2 c/o	fork type	CR-M2SF	1SVR405651R1300		10	0.040 (0.088)
Standard socket for 2/4 c/o		CR-M4SF	1SVR405651R3300			0.048 (0.106)
Plastic holder		CR-MH	1SVR405659R1000		10	0.003 (0.007)
Metal holder		CR-MH1	1SVR405659R1100		10	0.0005 (0.001)
Jumper bar for sockets with screw connection		CR-MJ	1SVR405658R6000		10	0.029 (0.064)
Marker		CR-MM	1SVR405658R1000		10	0.0005 (0.001)

Bold printed products = stocked products

Pluggable interface relays

Ordering details



2CDC291 005 S0011

CR-P/M ...

Ordering details - CR-P/M range (all products stocked)

Rated control supply voltage	Description	Version	Type	Order code	Price	Pkg qty	Weight (1 pce)	
							kg	(lb)
6-220 V DC	Diode - Reverse polarity protection/ free wheeling diode	A1+, A2-	CR-P/M 22	1SVR405651R0000		10	0.003	(0.007)
6-24 V DC	Diode and LED - Reverse polarity protection/ free wheeling diode	red, A1+, A2-	CR-P/M 42	1SVR405652R0000		10	0.003	(0.007)
24-60 V DC		green, A1+, A2-	CR-P/M 42V	1SVR405652R1000				
110 V DC		red, A1+, A2-	CR-P/M 42B	1SVR405652R4000				
6-24 V AC		green, A1+, A2-	CR-P/M 42BV	1SVR405652R4100				
24-60 V AC	Spark quenching	red, A1+, A2-	CR-P/M 42C	1SVR405652R9000		10	0.003	(0.007)
110-230 V AC/DC		green, A1+, A2-	CR-P/M 42CV	1SVR405652R9100				
6-24 V AC			CR-P/M 52B	1SVR405653R0000				
24-60 V AC	Spark quenching		CR-P/M 52D	1SVR405653R4000		10	0.003	(0.007)
110-230 V AC/DC			CR-P/M 52C	1SVR405653R1000				
6-24 V AC/DC		Diode, LED and reverse polarity protection	red, for DC A1+, A2-	CR-P/M 62				
24-60 V AC/DC	green, for DC A1+, A2-		CR-P/M 62V	1SVR405654R1000				
110 V DC	red, for DC A1+, A2-		CR-P/M 62E	1SVR405654R4000				
110-230 V AC	green, for DC A1+, A2-		CR-P/M 62EV	1SVR405654R4100				
6-24 V AC/DC	Varistor and LED Overvoltage protection	red, for DC A1+, A2-	CR-P/M 92	1SVR405654R0100		10	0.003	(0.007)
24-60 V AC/DC		green, for DC A1+, A2-	CR-P/M 92V	1SVR405654R1100				
110 V DC		red, for DC A1+, A2-	CR-P/M 62C	1SVR405655R0000				
110-230 V AC		green, for DC A1+, A2-	CR-P/M 62CV	1SVR405655R1000				
24 V AC	Overvoltage protection	red, for DC A1+, A2-	CR-P/M 62D	1SVR405655R4000		10	0.003	(0.007)
115 V AC		green, for DC A1+, A2-	CR-P/M 62DV	1SVR405655R4100				
230 V AC		red, for DC A1+, A2-	CR-P/M 92C	1SVR405655R0100				
230 V AC	Overvoltage protection	green, for DC A1+, A2-	CR-P/M 92CV	1SVR405655R1100		10	0.002	(0.004)
24 V AC			CR-P/M 72	1SVR405656R0000				
115 V AC			CR-P/M 72A	1SVR405656R1000				
230 V AC			CR-P/M 82	1SVR405656R2000				

Connection diagrams

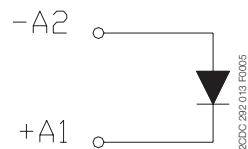

CR-P/M 22

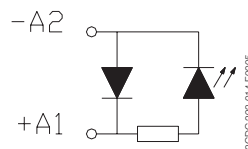

CR-P/M 42, CR-P/M 42C, CR-P/M 42BV, CR-P/M 42B, CR-P/M 42V, CR-P/M 42CV

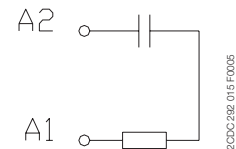

CR-P/M 52B, CR-P/M 52D, CR-P/M 52C

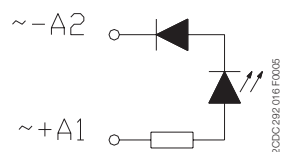

CR-P/M 62, CR-P/M 92, CR-P/M 62EV, CR-P/M 62E, CR-P/M 62V, CR-P/M 92V

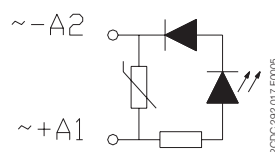

CR-P/M 62C, CR-P/M 92C, CR-P/M 62D, CR-P/M 62CV, CR-P/M 92CV

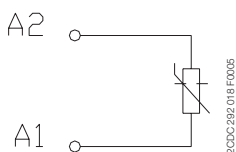

CR-P/M 72, CR-P/M 72A, CR-P/M 82

Pluggable interface relays

Ordering details



2CDC 291 047 F0004

CR-U

Description

Interface relays are widely used in various industrial applications:

As an interface they link the electronic controlling, e.g. PLC (programmable logic controller), PC or field bus systems, to the sensor / actuator level. Here, they take on various functions: Switching of AC or DC loads with different resistive, inductive and capacitive parts, switching voltages from a few mV up to 250 V, switching currents from a few mA up to 16 A, amplification of weak control signals, electrical isolation of control and load circuits, and signal multiplying. In contrast to electronic switching devices, interface relays don't use additional internal protective circuits and thus are overload-proof against short-time variations like current or voltage peaks.

Ordering details - CR-U range

Rated control supply voltage	Outputs	Contact ratings	Type	Order code	Price	Pkg qty	Weight (1 pce) kg (lb)				
12 V DC	2 c/o without LED	250 V, 10 A	CR-U012DC2	1SVR405621R4000		10	0.083 (0.183)				
24 V DC			CR-U024DC2	1SVR405621R1000							
48 V DC			CR-U048DC2	1SVR405621R6000							
110 V DC			CR-U110DC2	1SVR405621R8000							
220 V DC			CR-U220DC2	1SVR405621R9000							
24 V AC			CR-U024AC2	1SVR405621R0000							
48 V AC			CR-U048AC2	1SVR405621R5000							
110 V AC			CR-U110AC2	1SVR405621R7000							
120 V AC			CR-U120AC2	1SVR405621R2000							
230 V AC			CR-U230AC2	1SVR405621R3000							
12 V DC			3 c/o without LED	250 V, 10 A	CR-U012DC3			1SVR405622R4000		10	0.083 (0.183)
24 V DC					CR-U024DC3			1SVR405622R1000			
48 V DC					CR-U048DC3			1SVR405622R6000			
110 V DC					CR-U110DC3			1SVR405622R8000			
125 V DC	CR-U125DC3	1SVR405622R8200									
220 V DC	CR-U220DC3	1SVR405622R9000									
24 V AC	CR-U024AC3	1SVR405622R0000									
48 V AC	CR-U048AC3	1SVR405622R5000									
60 V AC	CR-U060AC3	1SVR405622R5200									
110 V AC	CR-U110AC3	1SVR405622R7000									
120 V AC	CR-U120AC3	1SVR405622R2000									
230 V AC	CR-U230AC3	1SVR405622R3000									
12 V DC	2 c/o with LED	250 V, 10 A			CR-U012DC2L	1SVR405621R4100		10	0.083 (0.183)		
24 V DC					CR-U024DC2L	1SVR405621R1100					
48 V DC			CR-U048DC2L	1SVR405621R6100							
110 V DC			CR-U110DC2L	1SVR405621R8100							
220 V DC			CR-U220DC2L	1SVR405621R9100							
24 V AC			CR-U024AC2L	1SVR405621R0100							
48 V AC			CR-U048AC2L	1SVR405621R5100							
110 V AC			CR-U110AC2L	1SVR405621R7100							
120 V AC			CR-U120AC2L	1SVR405621R2100							
230 V AC			CR-U230AC2L	1SVR405621R3100							
12 V DC			3 c/o with LED	250 V, 10 A	CR-U012DC3L	1SVR405622R4100				10	0.083 (0.183)
24 V DC					CR-U024DC3L	1SVR405622R1100					
48 V DC					CR-U048DC3L	1SVR405622R6100					
110 V DC					CR-U110DC3L	1SVR405622R8100					
220 V DC	CR-U220DC3L	1SVR405622R9100									
24 V AC	CR-U024AC3L	1SVR405622R0100									
48 V AC	CR-U048AC3L	1SVR405622R5100									
110 V AC	CR-U110AC3L	1SVR405622R7100									
120 V AC	CR-U120AC3L	1SVR405622R2100									
230 V AC	CR-U230AC3L	1SVR405622R3100									



2CDC 291 007 S0011

CR-U2S

Ordering details - Accessories

Version	Type	Order code	Price	Pkg qty	Weight (1 pce) kg (lb)
Socket for 2 c/o and module	CR-U2S	1SVR405670R0000		10	
Socket for 3 c/o and module	CR-U3S	1SVR405660R0000			
Socket for 3 c/o	CR-U3E	1SVR405660R0100			
Socket small for 2 c/o	CR-U2SM	1SVR405670R1100			
Socket small for 3 c/o	CR-U3SM	1SVR405660R1100			
Holder for CR-U socket	CR-UH	1SVR405669R0000			

Bold printed products = stocked products

Pluggable interface relays

Ordering details



CR-U...

2CDC 291 004 S0011

Ordering details - CR-U range (all products stocked)

Rated control supply voltage	Description	Version	Type	Order code	Price	Pkg qty	Weight (1 pce)	
							kg	(lb)
6-220 V DC	Diode - Reverse polarity protection/ free wheeling diode	A1+, A2-	CR-U 21	1SVR405661R0000		10	0.007	(0.015)
6-24 V DC	Diode and LED - Reverse polarity protection/ free wheeling diode	red, A1+, A2-	CR-U 41	1SVR405662R0000		10	0.007	(0.015)
24-60 V DC		green, A1+, A2-	CR-U 41V	1SVR405662R1000				
110 V DC		red, A1+, A2-	CR-U 41B	1SVR405662R4000				
6-24 V AC/DC		green, A1+, A2-	CR-U 41BV	1SVR405662R4100				
24-60 V AC/DC	Spark quenching	red, A1+, A2-	CR-U 41C	1SVR405662R9000		10	0.007	(0.015)
110-230 V AC/DC		green, A1+, A2-	CR-U 41CV	1SVR405662R9100				
6-24 V AC/DC			CR-U 51B	1SVR405663R0000				
24-60 V AC/DC	Diode and LED	red, for DC A1+, A2-	CR-U 61	1SVR405664R0000		10	0.007	(0.015)
110-230 V AC		green, for DC A1+, A2-	CR-U 61V	1SVR405664R1000				
6-24 V AC/DC		red, for DC A1+, A2-	CR-U 61E	1SVR405664R4000				
24-60 V AC/DC	Varistor and LED Overvoltage protection	green, for DC A1+, A2-	CR-U 61EV	1SVR405664R4100		10	0.007	(0.015)
110 V DC		red, for DC A1+, A2-	CR-U 91	1SVR405664R0100				
110-230 V AC	Overvoltage protection, varistor	green, for DC A1+, A2-	CR-U 91V	1SVR405664R1100		10	0.007	(0.015)
6-24 V AC/DC		red, for DC A1+, A2-	CR-U 61C	1SVR405665R0000				
24-60 V AC/DC	Multifunction time module	green, for DC A1+, A2-	CR-U 61CV	1SVR405665R1000		10	0.007	(0.015)
110 V DC		red, for DC A1+, A2-	CR-U 61D	1SVR405665R4000				
110-230 V AC		green, for DC A1+, A2-	CR-U 61DV	1SVR405665R4100				
24 V AC	Overvoltage protection, varistor	red, for DC A1+, A2-	CR-U 91C	1SVR405665R0100		10	0.007	(0.015)
115 V AC			CR-U 71	1SVR405666R0000				
230 V AC			CR-U 71A	1SVR405666R1000				
24-240 V AC/DC	Multifunction time module		CR-U 81	1SVR405666R2000		10	0.014	(0.031)
		pluggable onto CR-U2S and CR-U3S	CR-U T	1SVR405667R0000				

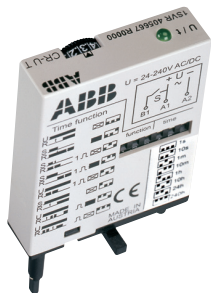

CR-U T

2CDC 291 032 F0005

Connection diagrams

All CR-U modules can be plugged onto sockets CR-U2S and CR-U3S.

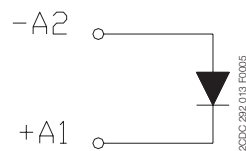

CR-U 21

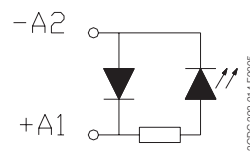

CR-U 41, CR-U 41B, CR-U 41C, CR-U 41V, CR-U 41BV, CR-U 41CV

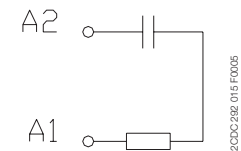

CR-U 51B, CR-U 51C CR-U 51D,

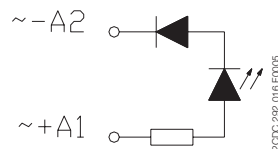

CR-U 61, CR-U 61V, CR-U 61E, CR-U 61EV, CR-U 91, CR-U 91V

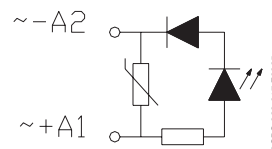

CR-U 61C, CR-U 61D, CR-U 91C, CR-U 61CV, CR-U 61DV CR-U 91CV

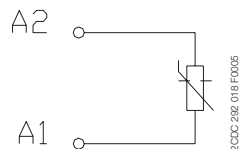

CR-U 71, CR-U 81 CR-U 71A,

Pluggable interface relays

Technical data

Input circuit - coil data

CR-P range



	Rated control supply voltage U_s	Rated frequency	Make voltage (at 20 °C)	Maximum voltage (at 55 °C)	Break voltage	Rated power	Coil resistance (at 20 °C)	Tolerance of coil resistance
DC coils	12 V DC	-	8.4 V DC	30.6 V DC	$\geq 0.1 U_s$	0.4-0.48 W	360 Ω	$\pm 10\%$
	24 V DC	-	16.8 V DC	61.2 V DC	$\geq 0.1 U_s$	0.4-0.48 W	1440 Ω	$\pm 10\%$
	48 V DC	-	33.6 V DC	122.4 V DC	$\geq 0.1 U_s$	0.4-0.48 W	5700 Ω	$\pm 10\%$
	110 V DC	-	77 V DC	280 V DC	$\geq 0.1 U_s$	0.4-0.48 W	25200 Ω	$\pm 10\%$
AC coils	24 V AC	50 / 60 Hz	19.2 V AC	28.8 V AC	$\geq 0.15 U_s$	0.75 VA	400 Ω	$\pm 10\%$
	48 V AC	50 / 60 Hz	38.4 V AC	57.6 V AC	$\geq 0.15 U_s$	0.75 VA	1550 Ω	$\pm 10\%$
	110 V AC	50 / 60 Hz	88 V AC	132 V AC	$\geq 0.15 U_s$	0.75 VA	8900 Ω	$\pm 10\%$
	120 V AC	50 / 60 Hz	96 V AC	144 V AC	$\geq 0.15 U_s$	0.75 VA	10200 Ω	$\pm 10\%$
	230 V AC	50 / 60 Hz	184 V AC	276 V AC	$\geq 0.15 U_s$	0.75 VA	38500 Ω	$\pm 10\%$

CR-M range



	Rated control supply voltage U_s	Rated frequency	Make voltage (at 20 °C)	Maximum voltage (at 55 °C)	Break voltage	Rated power	Coil resistance (at 20 °C)	Tolerance of coil resistance
DC coils	12 V DC	-	9.6 V DC	13.2 V DC	$\geq 0.1 U_s$	0.9 W	160 Ω	$\pm 10\%$
	24 V DC	-	19.2 DC	26.4 V DC	$\geq 0.1 U_s$	0.9 W	640 Ω	$\pm 10\%$
	48 V DC	-	38.4 V DC	52.8 V DC	$\geq 0.1 U_s$	0.9 W	2600 Ω	$\pm 10\%$
	60 V DC	-	48.0 V DC	66.0 V DC	$\geq 0.1 U_s$	0.9 W	4000 Ω	$\pm 10\%$
	110 V DC	-	88 V DC	121 V DC	$\geq 0.1 U_s$	0.9 W	13600 Ω	$\pm 10\%$
	125 V DC	-	100 V DC	137.5 V DC	$\geq 0.1 U_s$	0.9 W	16000 Ω	$\pm 10\%$
	220 V DC	-	176 V DC	242 V DC	$\geq 0.1 U_s$	0.9 W	54000 Ω	$\pm 10\%$
AC coils	24 V AC	50 / 60 Hz	19.2 V AC	26.4 V AC	$\geq 0.2 U_s$	1.6 VA	158 Ω	$\pm 10\%$
	48 V AC	50 / 60 Hz	38.4 V AC	52.8 V AC	$\geq 0.2 U_s$	1.6 VA	640 Ω	$\pm 10\%$
	60 V AC	50 / 60 Hz	48.0 V AC	66.0 V AC	$\geq 0.2 U_s$	1.6 VA	930 Ω	$\pm 10\%$
	110 V AC	50 / 60 Hz	88 V AC	121 V AC	$\geq 0.2 U_s$	1.6 VA	3450 Ω	$\pm 10\%$
	120 V AC	50 / 60 Hz	96 V AC	132 V AC	$\geq 0.2 U_s$	1.6 VA	3770 Ω	$\pm 10\%$
	230 V AC	50 / 60 Hz	184 V AC	253 V AC	$\geq 0.2 U_s$	1.6 VA	16100 Ω	$\pm 10\%$

CR-U range



	Rated control supply voltage U_s	Rated frequency	Make voltage (at 20 °C)	Maximum voltage (at 55 °C)	Break voltage	Rated power	Coil resistance (at 20 °C)	Tolerance of coil resistance
DC coils	12 V DC	-	9.6 V DC	13.2 V DC	$\geq 0.1 U_s$	1.5 W	110 Ω	$\pm 10\%$
	24 V DC	-	19.2 V DC	26.4 V DC	$\geq 0.1 U_s$	1.5 W	430 Ω	$\pm 10\%$
	48 V DC	-	38.4 V DC	52.8 V DC	$\geq 0.1 U_s$	1.5 W	1750 Ω	$\pm 10\%$
	110 V DC	-	88.0 V DC	121.0 V DC	$\geq 0.1 U_s$	1.5 W	9200 Ω	$\pm 10\%$
	125 V DC	-	96.0 V DC	132.0 V DC	$\geq 0.1 U_s$	1.5 W	11000 Ω	$\pm 10\%$
	220 V DC	-	176.0 V DC	242.0 V DC	$\geq 0.1 U_s$	1.5 W	37000 Ω	$\pm 10\%$
AC coils	24 V AC	50 / 60 Hz	19.2 V AC	26.4 V AC	$\geq 0.15 U_s$	2.8 VA (50 Hz) 2.5 VA (60 Hz)	75 Ω	$\pm 10\%$
	48 V AC	50 / 60 Hz	38.4 V AC	52.8 V AC	$\geq 0.15 U_s$	2.8 VA (50 Hz) 2.5 VA (60 Hz)	305 Ω	$\pm 10\%$
	60 V AC	50 / 60 Hz	48.0 V AC	66.0 V AC	$\geq 0.15 U_s$	2.8 VA (50 Hz) 2.5 VA (60 Hz)	475 Ω	$\pm 10\%$
	110 V AC	50 / 60 Hz	88.0 V AC	121.0 V AC	$\geq 0.15 U_s$	2.8 VA (50 Hz) 2.5 VA (60 Hz)	1700 Ω	$\pm 10\%$
	120 V AC	50 / 60 Hz	96.0 V AC	132.0 V AC	$\geq 0.15 U_s$	2.8 VA (50 Hz) 2.5 VA (60 Hz)	1910 Ω	$\pm 10\%$
	230 V AC	50 / 60 Hz	184.0 V AC	253.0 V AC	$\geq 0.15 U_s$	2.8 VA (50 Hz) 2.5 VA (60 Hz)	7080 Ω	$\pm 10\%$

Pluggable interface relays

Technical data

Type		CR-P...1	CR-P...2	CR-M...2	CR-M...3	CR-M...4	CR-U...2	CR-U...3	
Output circuit(s)		11-12/14	11-12/14 21-22/24	11-12/14 21-22/24	11-12/14 21-22/24 31-32/34	11-12/14 21-22/24 31-32/34 41-42/44	11-12/14 31-32/34	11-12/14 21-22/24 31-32/34	
Kind of output		Relay, 1 c/o	Relay, 2 c/o	Relay, 2 c/o	Relay, 3 c/o	Relay, 4 c/o	Relay, 2 c/o	Relay, 3 c/o	
Contact material		AgNi	AgNi AgNi/Au 5 µm	AgNi	AgNi	AgNi AgNi/Au 5 µm	AgNi		
Rated operational voltage U _o (VDE 0110, IEC 60947-1)		250 V							
Minimum switching voltage		5 V		10 V	10 V	5 V	10 V		
Maximum switching voltage	DC	300 V DC		250 V DC					
	AC	440 V AC		250 V AC			440 V AC		
Minimum switching current		5 mA (AgNi)	2 mA (AgNi/Au)	5 mA (AgNi)	5 mA (AgNi)	2 mA (AgNi/Au)	5 mA		
Rated free air thermal current I _{th}		16 A	8 A	12 A	10 A	6 A	10 A		
Rated operational current (IEC 60947-5-1)	AC12 (resistive) 230 V	16 A	8 A	12 A	10 A	6 A	10 A		
	AC15 (inductive) 230 V	1.5 A	1.5 A	1.5 A	1.5 A	1 A	1.5 A		
	AC15 (inductive) 120 V	3 A							
	DC12 (resistive) 24 V	16 A	8 A	12 A	10 A	6 A	10 A		
	DC13 (inductive) 24 V	2.5 A	2 A	2.5 A	2.5 A	2 A	2 A		
	DC13 (inductive) 120 V	0.22 A							
	DC13 (inductive) 250 V	0.1 A							
AC rating (UL 508)	Utilization category (pilot duty) (Contact rating code designation)	B300		B300				B300	
	max. rated operational voltage	300 V AC		300 V AC				300 V AC	
	Max. continuous thermal current at utilization category	5 A		5 A	5 A	2.5 A		5 A	
	Max. making / breaking apparent power at utilization category	3600 / 360 VA		3600 / 360 VA			1800 / 180 VA		3600/360 VA
	Utilization category (resistive) (CSA22.2 No.14...)	16 A, 250 V AC	8 A, 250 V AC	10 A, 250 V AC 12 A, 150 V AC	6 A, 250 V AC 10 A, 150 V AC	5 A, 250 V AC 10 A, 150 V AC	10 A, 250 V AC		
	DC rating * (UL 508; NEMA ICS-5)	Utilization category (pilot duty) (Contact rating code designation)	R300						
	Max. rated operational voltage	300 V DC							
	Max. continuous thermal current at utilization category	1 A							
	Max. making / breaking apparent power at utilization category	28 VA							
	Utilization category (resistive) (CSA22.2 No.14...)		10 A, 24 V DC				10 A, 28 V DC		
Maximum making (inrush) current		30 A		24 A	20 A	12 A	20 A		
Minimum switching power		0.3 W (AgNi), 0.05 W (AgNi/Au)		0.3 W (AgNi), 0.1 W (AgNi/Au)			0.3 W		
Maximum switching (breaking) power	AC1 (resistive)	4000 VA	2000 VA	3000 VA	2500 VA	1500 VA	2500 VA		
Contact resistance		≤ 100 mΩ							
Maximum operating frequency	rated load AC-1	600 switching cycles/h		1200 switching cycles/h			12000 switching cycles/h		
	without load	72000 switching cycles/h		18000 switching cycles/h			12000 switching cycles/h		
Mechanical lifetime		> 3 x 10 ⁷ switching cycles		> 2 x 10 ⁷ switching cycles					
Electrical lifetime	electrical AC1 (resistive)	> 0.7 x 10 ⁵ switching cycles (16 A, 250 V)	> 10 ⁵ switching cycles (8 A, 250 V)	(12 A, 250 V)	(10 A, 250 V)	(6 A, 250 V)	> 10 ⁵ switching cycles (10 A, 250 V)		
		cos φ see reduction factor F							
	Response time		typ. 7 ms		typ. 13 ms (DC), 10 ms (AC)			typ. 18 ms (DC), 12 ms (AC)	
Release time		typ. 3 ms		typ. 3 ms (DC), 8 ms (AC)			typ. 7 ms (DC), 10 ms (AC)		
Isolation data									
Rated insulation voltage		400 V AC		250 V AC					
Insulation class		C250 / B400		C250 / B250			C250		
Rated impulse withstand voltage U _{imp}	between coil and contacts	5 kV AC		2.5 kV AC					
	between open contacts	1 kV AC		1.5 kV AC					
	between c/o (SPDT) contacts		2.5 kV AC	2.5 kV AC		≥ 2 kV AC	2 kV AC		

* Those ratings are based on different type tests but they are not covered by the cULus or CSA approvals.

Pluggable interface relays

Technical data, Load limit curves

Type		CR-P...1	CR-P...2	CR-M...2	CR-M...3	CR-M...4	CR-U...2	CR-U...3	
Clearance	between coil and contacts	≥ 10 mm		≥ 2.5 mm		≥ 1.6 mm	≥ 3 mm		
Creepage distance	between coil and contacts	≥ 10 mm		≥ 4 mm		≥ 3.2 mm	≥ 4.2 mm		
Overvoltage category		III		III		II	III		
Pollution degree		3		3		2	3		
General data									
Dimensions (W x H x D) when mounted		12.7 x 29 x 15.7 mm		21.2 x 27.5 x 35.6 mm			35 x 35 x 54.4 mm		
Weight		14 g (0.031 lb)		35 g (0.077 lb)			83 g (0.18 lb)		
Mounting		on socket (see accessories)							
Mounting position		any							
Degree of protection		IP 67			IP 40				
Electrical connection									
Connection		by socket							
Environmental data									
Ambient temperature range	operation	DC: -40...+85 °C; AC: -40...+70 °C			DC: -40...+70 °C; AC: -40...+55 °C				
	storage	-40 ... +85 °C							
Vibration resistance 10-150 Hz	n/o contact	10 g		5 g		5 g			
	n/c contact	10 g		5 g		5 g			
Shock resistance	n/o contact	30 g		20 g		10 g			
	n/c contact	30 g		20 g		10 g			
Standards									
Product standard		EN 61810-1, EN 60255-23 IEC 60664-1			EN 60810-1, EN 60255-23, IEC 61810-7			EN 60255-1-00	
Low Voltage Directive		2006/95/EC							

Approvals see page 5/6.

Load limit curves - Maximum switching power at resistive DC load

CR-P with 1 c/o contact

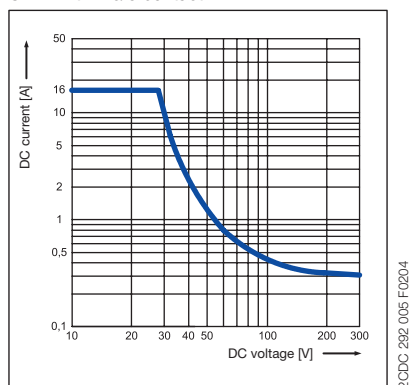

CR-P with 2 c/o contacts

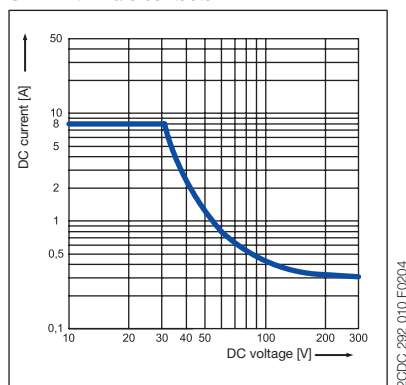

CR-U with 2 and 3 c/o contacts

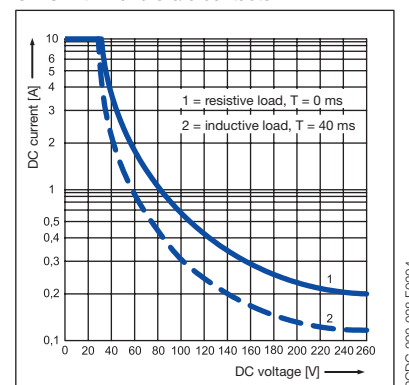

CR-M with 2 c/o contacts

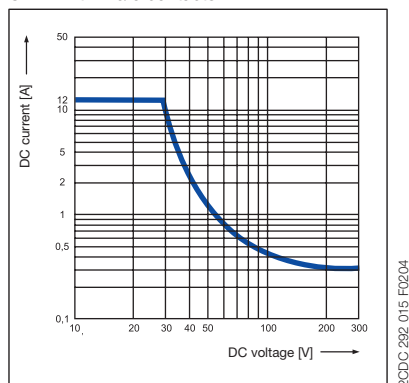

CR-M with 3 c/o contacts

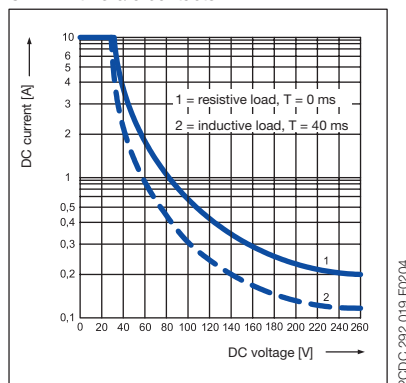

CR-M with 4 c/o contacts

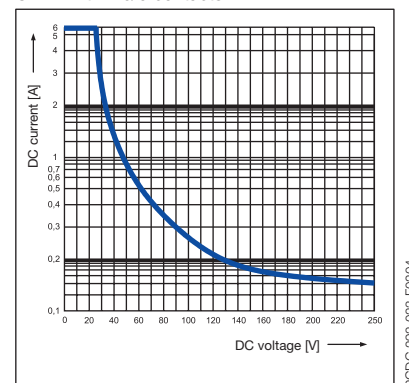

Pluggable interface relays

Load limit curves

Load limit curves - Electrical lifetime at resistive AC load

5

CR-P with 1 c/o contact

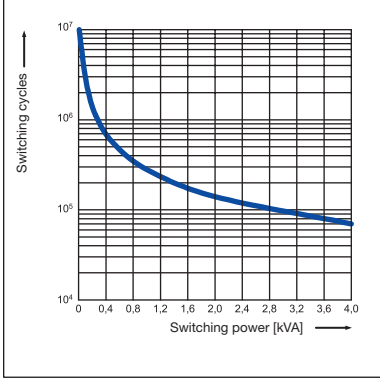

CR-P with 2 c/o contacts

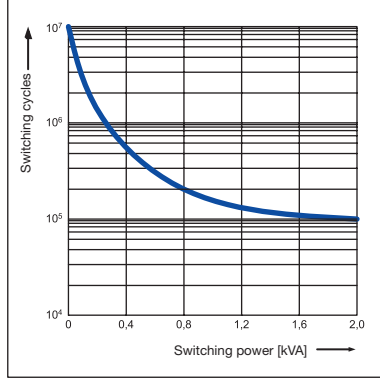

CR-U with 2 and 3 c/o contacts

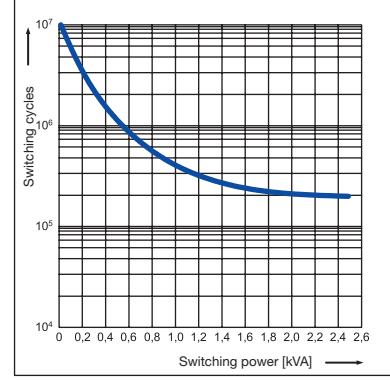

CR-M with 2 c/o contacts

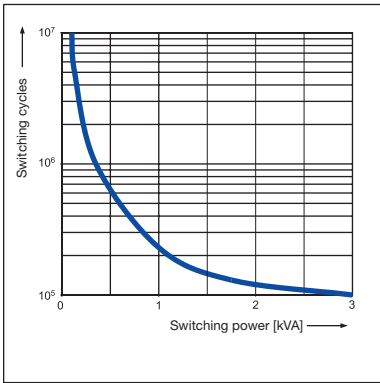

CR-M with 3 c/o contacts

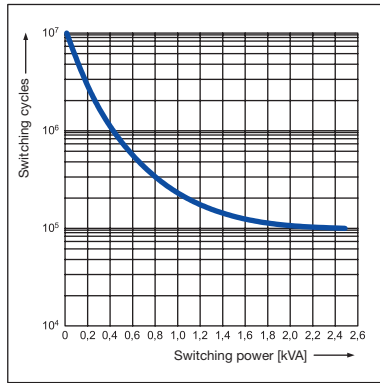

CR-M with 4 c/o contacts

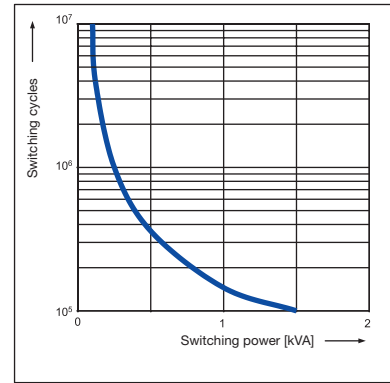

Reduction factor F at inductive AC load

CR-P

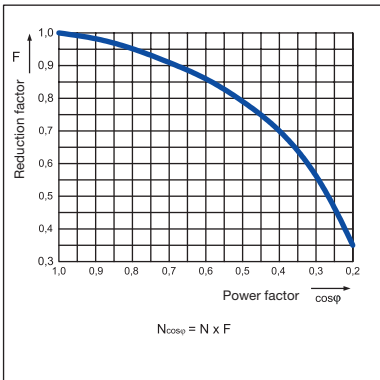

CR-M

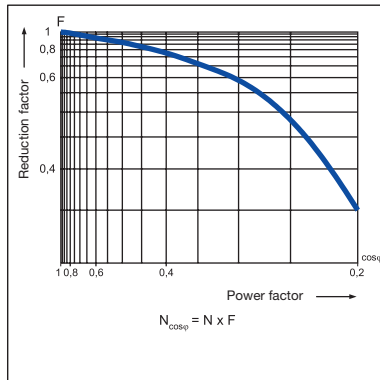

CR-U

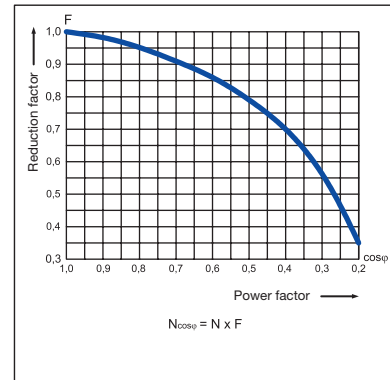

Pluggable interface relays

Connection diagrams

Connection diagrams

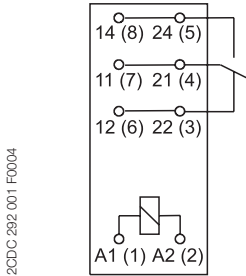

CR-P with 1 c/o contact

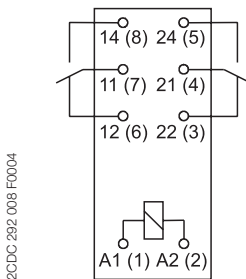

CR-P with 2 c/o contacts

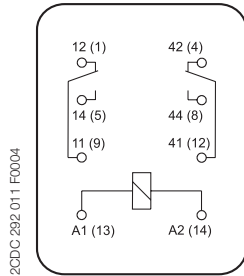

CR-M with 2 c/o contacts

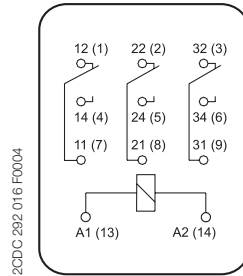

CR-M with 3 c/o contacts

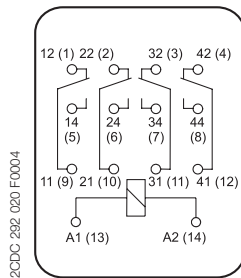

CR-M with 4 c/o contacts

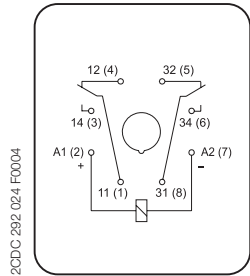

CR-U with 2 c/o contacts

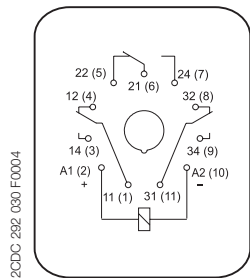

CR-U with 3 c/o contacts

Dimensional drawings

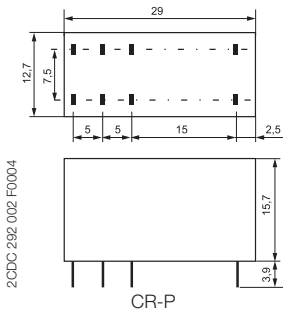

CR-P

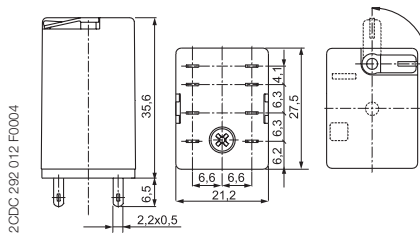

CR-M with 2 c/o contacts

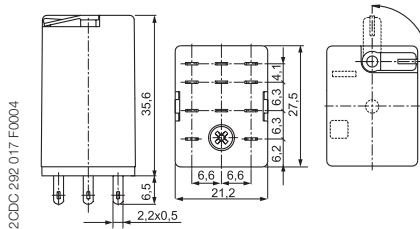

CR-M with 3 c/o contacts

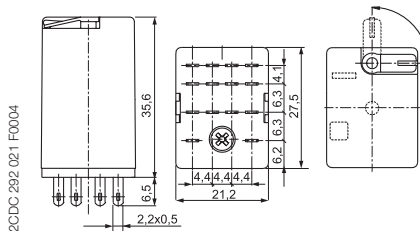

CR-M with 4 c/o contacts

Dimensions in mm and inches

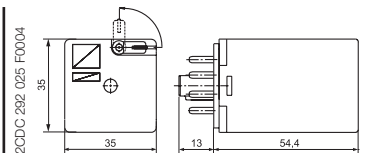

CR-U with 2 c/o contacts

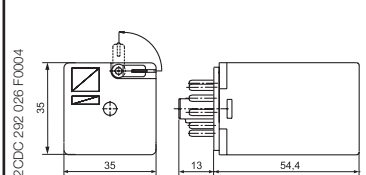

CR-U with 3 c/o contacts

Pluggable interface relays

Connection diagrams

Dimensional drawings

Sockets for screw connection

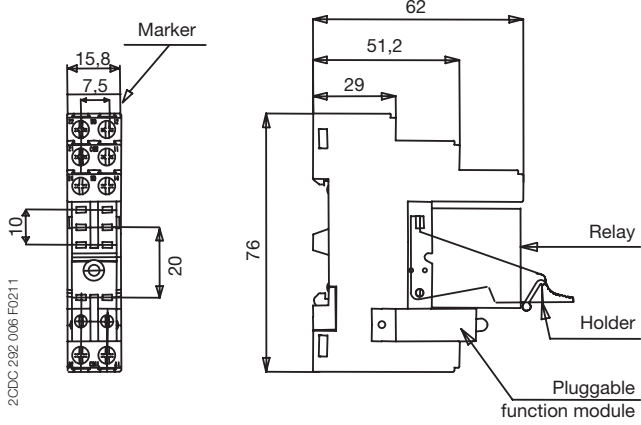

CR-PLS

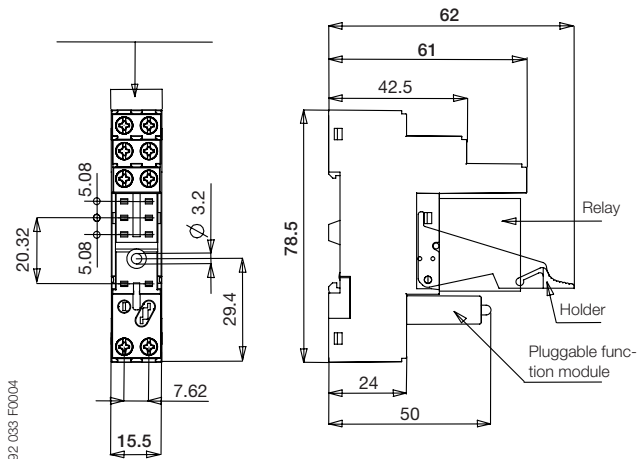

CR-PLSx

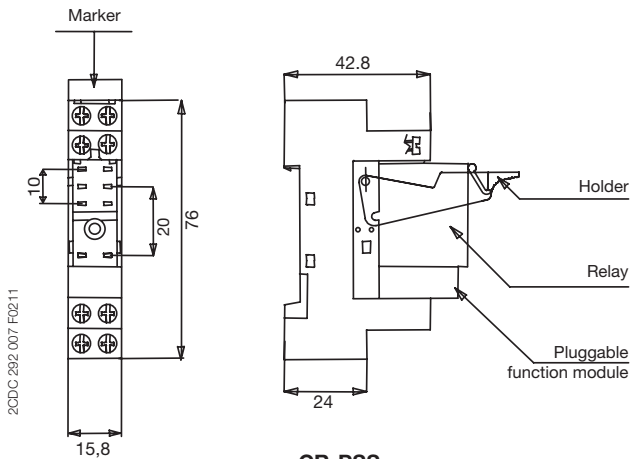

CR-PSS

Dimensions in mm and inches

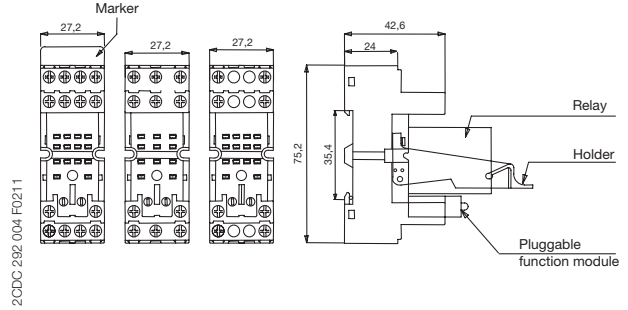

CR-M2SS - CR-M3SS - CR-M4SS

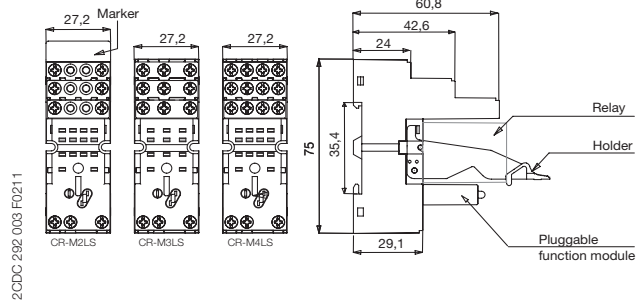

CR-M2LS - CR-M3LS - CR-M4LS

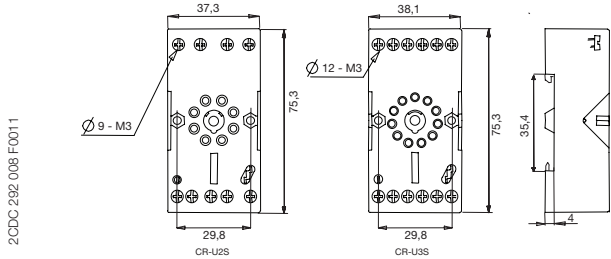

CR-U2S - CR-U3S

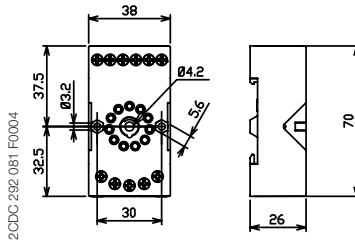

CR-U3E

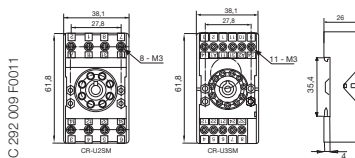

CR-U2SM

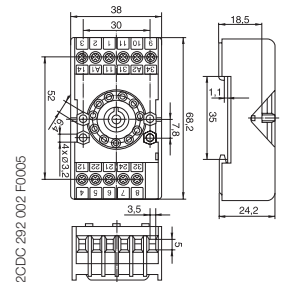

CR-U3SM

Pluggable interface relays

Connection diagrams

Dimensional drawings

Dimensions in mm and inches

Sockets for spring connection

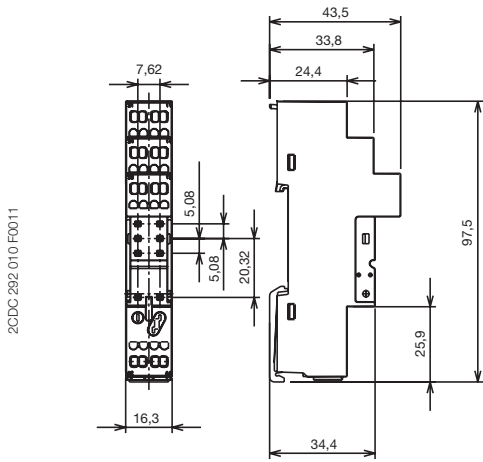

CR-PLC

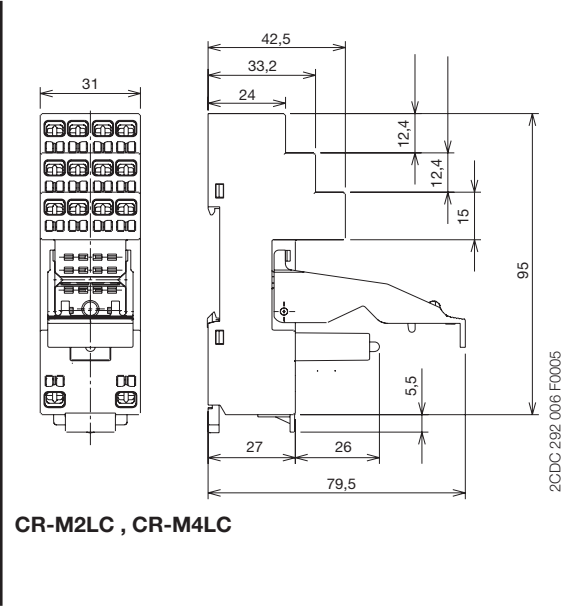

CR-M2LC , CR-M4LC

Jumper

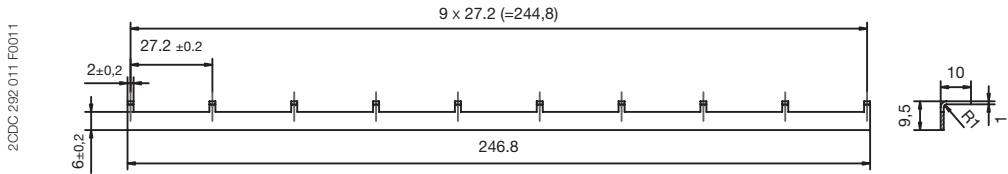

CR-PJ

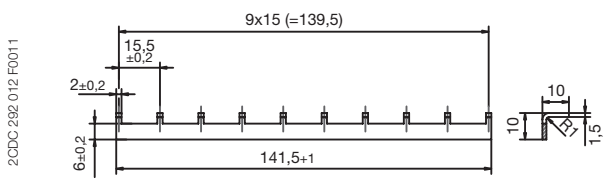

CR-MJ

Interface relays and optocouplers R500 / R600 range

Product group picture

5

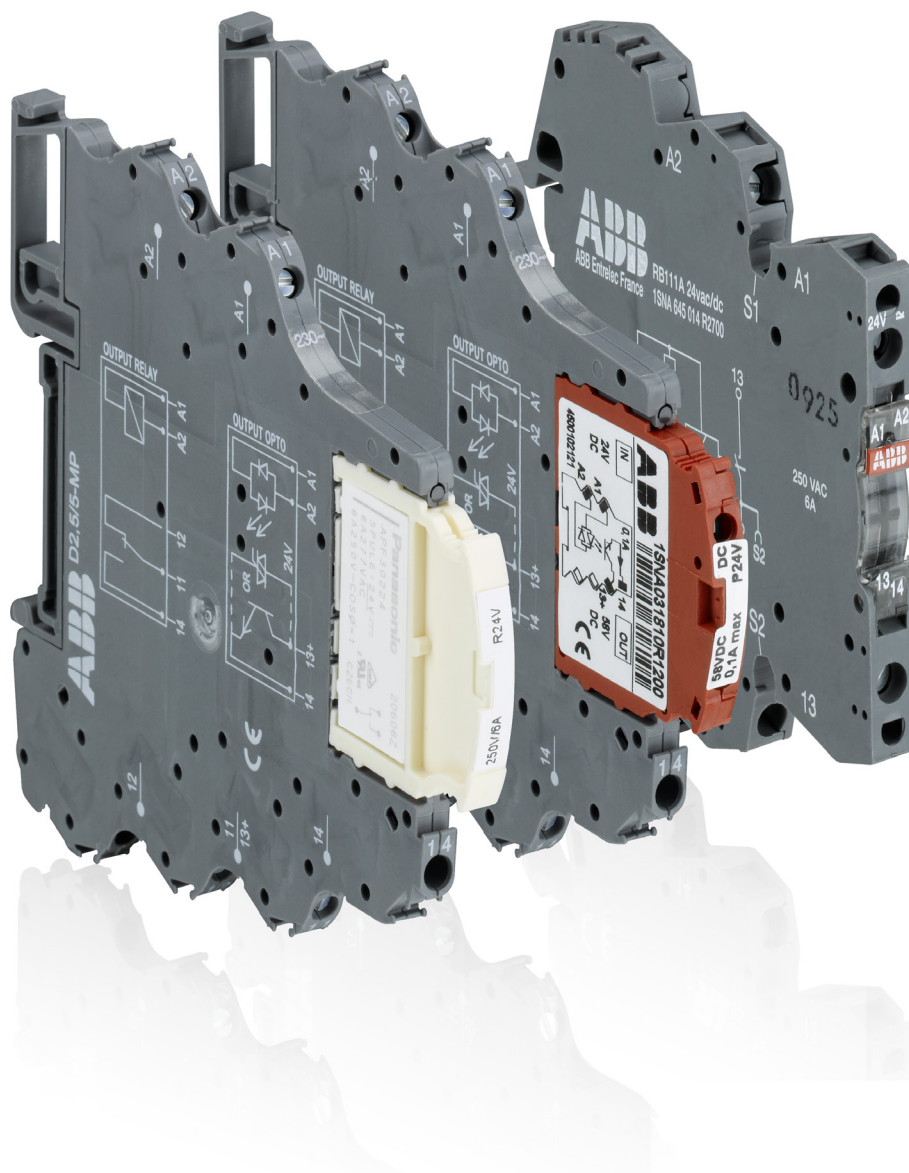

Interface relays and optocouplers R500 / R600 range

Table of contents

Interface relays and optocouplers R500/R600 range	
Table of contents	5/22
Benefits and advantages	5/23
Type designators	5/24
Interface relays and optocouplers R500 range	5/25
Table of contents	5/26
Interface relays R500 range	5/27
Table of contents	5/28
Selection	5/29
Ordering details	5/30
Technical information	5/31
Notes	5/32
Optocouplers R500 range	5/33
Table of contents	5/34
Selection	5/35
Ordering details	5/36
Connection diagrams	5/37
Technical data	5/38
Interface relays and optocouplers R600 range	5/45
Table of contents	5/46
Interface relays R600 range	5/47
Table of contents	5/48
Benefits and advantages	5/49
Selection	5/51
Ordering details	5/53
Connection diagrams	5/55
Technical data	5/56
General technical data	5/61
Dimensional drawings, Load limit curves	5/62
Optocouplers R600 range	5/63
Table of contents	5/64
Selection	5/65
Ordering details	5/67
Connection diagrams	5/68
Technical data	5/69

Interface relays and optocouplers R500 / R600 range

Benefits and advantages



2CDC 281 012 F0013

R500 series

It is our range offering pluggable functions

- Spacing : 5.08 mm (the smallest in the market)
- Wire size : 2.5 mm² (4 mm² solid)
- Contact type : 1 SPDT from 10 mA to 6 A / 250 V



2CDC 281 024 F0013

R600 series

Standard range in screw clamp or spring clamp versions

- Spacing : 6 mm or 12 mm
- Wire size : 2.5 mm² (4 mm² solid wire)
- Contact type : 1 NO, 1 NC, 1 SPDT, 1 DPDT from 1 mA to 8 A / 250 V

In today's automation systems, PLCs are the core of industry. They link sensors and actuators to the process, which are connected to the PLC via conventional wires.



However these PLCs are not completely isolated from the industrial environment, hence over voltage picks and transient currents can affect their operating functions. And additionally, their application field is often limited to 24 VDC / 100 mA.

So, with the aim to adapt application voltage and/or current and provide as well the right electrical isolation to the PLC, it is recommended to install per I/O the right interface providing both voltage-current level adaptation and isolation protection.

This interfacing is possible thanks to ABB's relays and optocouplers ranges, which offer wide adaptation in both voltage (from 5 to 400 V) and current (from 10-7 to 16 A) as well as high isolation between input and output from 2 to 4 KV.

Interface relays and optocouplers R500 / R600 range

Type designators

SERIES	CODE	NB OF RELAYS	CONTACT TYPE	NB OF CONTACTS PER RELAY	PARTICULARITIES			
R 600 	<table border="1"><tr><td>R</td><td>B</td></tr></table>	R	B	<input type="checkbox"/>	<input type="checkbox"/>	<input type="checkbox"/>	<input type="checkbox"/>	
R	B							
R 600 	<table border="1"><tr><td>R</td><td>B</td><td>R</td></tr></table>	R	B	R	<input type="checkbox"/>	<input type="checkbox"/>	<input type="checkbox"/>	<input type="checkbox"/>
R	B	R						
R 500	<table border="1"><tr><td>D</td><td>2,5/5</td><td>R</td></tr></table>	D	2,5/5	R	<input type="checkbox"/>	<input type="checkbox"/>	<input type="checkbox"/>	<input type="checkbox"/>
D	2,5/5	R						
		↓ 1	↓ 0 1 2	↓ 1 2	↓ None A B R I			

Description of contact types



Features

None Input voltage DC
A Input voltage AC/DC

R

RC circuit protection :
 - Input protection against leakage current

- Increases relay contacts life

I Switch to force the coil for maintenance and/or installation purposes

Auto A1
 off
 Manu A3

Interface relays and optocouplers R500 range

Product group picture

5

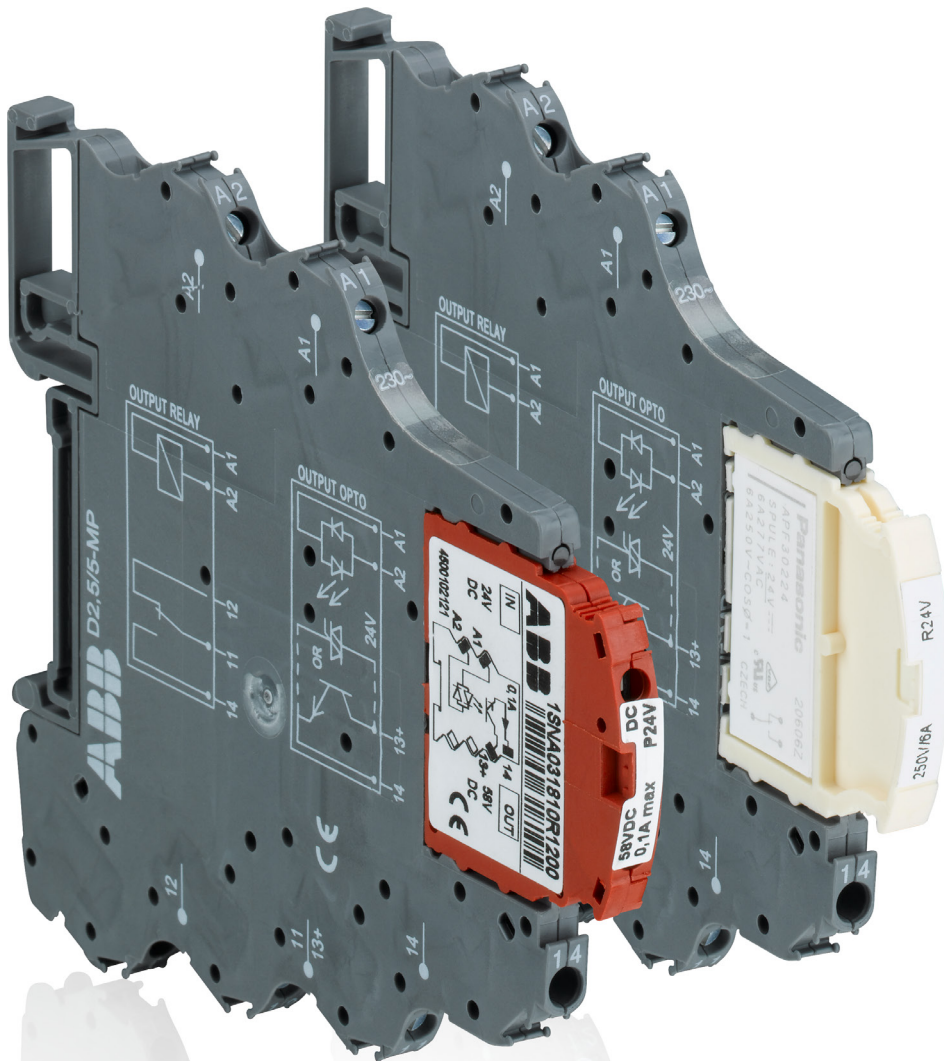

Interface relays and optocouplers R500 range

Table of contents

Interface relays and optocouplers R500 range	
Product group picture	5/25
Table of contents	5/26
Interface relays R500 range	5/27
Product group picture	5/27
Table of contents	5/28
Selection	5/29
Ordering details	5/30
Technical information	5/31
Optocouplers R500 range	5/33
Product group picture	5/33
Table of contents	5/34
Selection	5/35
Ordering details	5/36
Connection diagrams	5/37
Technical data	5/38

Interface relays R500 range

Product group picture

5

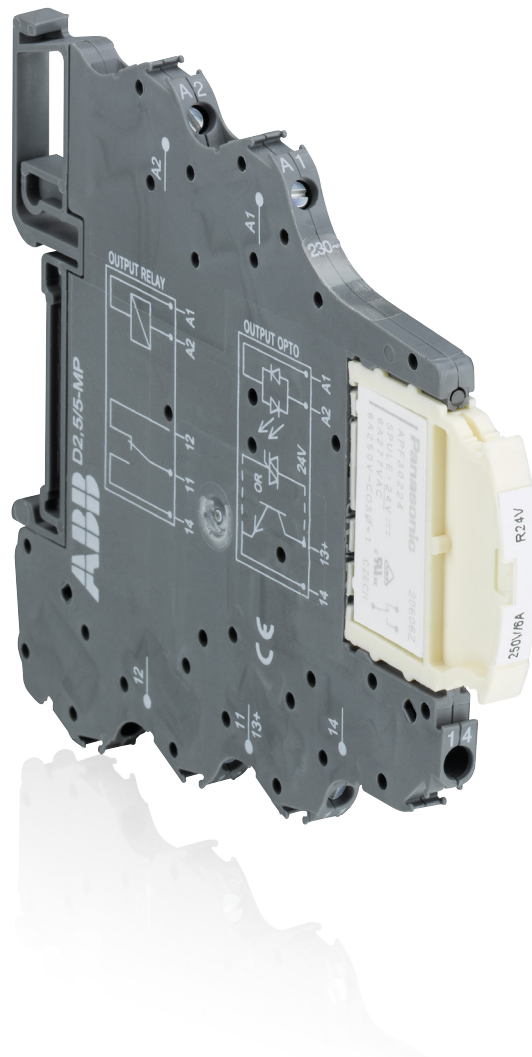

Interface relays R500 range

Table of contents

Interface relays R500 range	
Table of contents	5/28
Selection	5/29
Ordering details	5/30
Technical information	5/31
Notes	5/32

Interface relays R500 range

Selection

Type	Order number
D 2,5/5-R121-24VDC	1SNA 645 047 R0000
D 2,5/5-R121L-24VDC	1SNA 645 547 R0200
D 2,5/5-R121AL-24VAC/DC	1SNA 645 021 R2600
D 2,5/5-R121AL-48VAC/DC	1SNA 645 521 R2000
D 2,5/5-R121BL-110VAC	1SNA 645 049 R1200
D 2,5/5-R121BL-230VAC	1SNA 645 549 R1400

Input voltage	
24 V DC	■ ■ ■
48 V DC	■
24 V AC	■
48 V AC	■
110 V AC	■
230 V AC	■

Output rating	
10 mA - 6 A	■ ■ ■ ■ ■ ■

Output contacts	
c/o	1 1 1 1 1 1

Type	
with LED	■ ■ ■ ■ ■
without LED	■

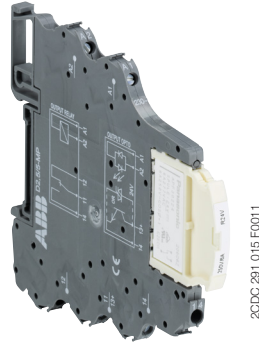

R500 series

Characteristics

- Spacing : 5.08 mm (the smallest in the market)
- Wire size : 2.5 mm² (4 mm² solid)
- Contact type : 1 SPDT from 10 mA to 6 A / 250 V

Interface relays R500 range

Ordering details

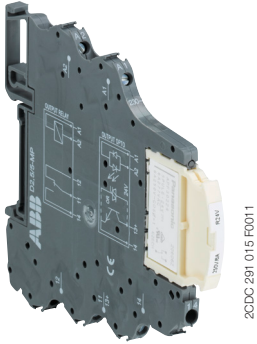

R500

2CDC 291 015 R0011

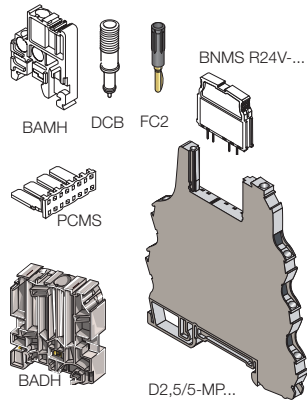

Description of R500 Relay	Type	Order code	Price	Pkg qty	Weight (1 pce) kg (lb)
Relay module 1 SPDT high level	D 2,5/5-R121-24VDC	1SNA607217R0200		10	0.032 (0.071)
	D 2,5/5-R121L-24VDC	1SNA607201R1300			
Relay module with LED 1 SPDT high level	D 2,5/5-R121AL-24VAC/DC	1SNA607231R0000		10	0.04 (0.088)
	D 2,5/5-R121AL-48VAC/DC	1SNA607232R0100			
	D 2,5/5-R121BL-110VAC	1SNA607264R1100			
	D 2,5/5-R121BL-230VAC	1SNA607265R1200			

R500 Accessories	Type	Order code	Price	Pkg qty	Weight (1 pce) kg (lb)
High end stop	BAMH 9,1 mm	1SNA114836R0000		50	
	BAMH V0 9,1 mm	1SNA194836R0100			
	BADH 12 mm	1SNA116900R2700			
Comb type jumper bar 2 to 22 poles		consult us			
Jumper bar 10 poles grey □	PCMS V0	1SNA205523R2200		8	
Relay / Opto base	D 2,5/5-MP	1SNA607224R0100		10	0.028 (0.062)
Relay / Opto base with LED 24 VDC	D 2,5/5-MP-24VDC	1SNA607222R0700			
Relay / Opto base with LED 24 VAC/VDC	D 2,5/5-MP-24VAC/DC	1SNA607260R2100		10	0.036 (0.0794)
Relay / Opto base with LED 48 VAC/VDC	D 2,5/5-MP-48VAC/DC	1SNA607261R1600			
Relay / Opto base with LED 110 VAC	D 2,5/5-MP-110VAC	1SNA607266R1300			
Relay / Opto base with LED 230 VAC	D 2,5/5-MP-230VAC	1SNA607267R1400			
Plug relay 24 V 1 SPDT 10 mA to 6 A	BNMS R24V-1	1SNA031820R1400		4	
Plug relay 24 V 1 SPDT 1 mA to 6 A	BNMS R24V-2	1SNA031847R1300			
Test device blue ■	DCB ¹⁾	1SNA105028R2100		10	
Test plug DIA. 2 mm	FC2	1SNA007865R2600			
Marking method	RC55	see marking			

¹⁾ Only on top decks

Connection diagrams

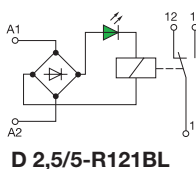
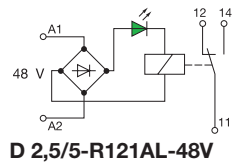
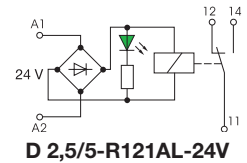
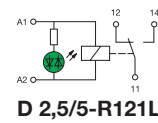
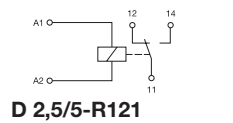

Interface relays R500 range

Technical information

Technical data

Relay : 1 SPDT high level with contact 10 mA to 6 A - 5.08mm 0.200" spacing

	D 2.5/5-R121	D 2.5/5-R121L	D 2.5/5-R121AL				D 2.5/5-R121BL	
Relay characteristics coil								
Rated voltage: +20%, -15% on DC ; 10%, -10% on AC	24 V DC	24 V DC	24 V AC	24 V DC	48 V AC	48 V DC	110 V AC	230 V AC
Frequency			50/60 Hz		50/60 Hz		50/60 Hz	50/60 Hz
Power	0.17 W	0.3 W	0.35 W	0.35 W	0.44 W	0.47 W	1.08 W	2.13 W
Rated current	7 mA	12 mA	12.4 mA	10 mA	7.6 mA	6.8 mA	8.4 mA	8 mA
Drop-out voltage at 20°C	2.4 V	2.4 V	4.8 V	4.8 V	10 V	10 V	25 V	45 V
Status device	green LED							

Relay characteristics contact

Type	1 SPDT								
Voltage switching range min./max.	12 V / 250 V AC								
Current switching range min./max.	10 mA / 6 A								
Load switching range	AC1 min./max.	0.6 VA / 1500 VA (ohmic load)							
	DC1 min./max.	0.6 W / 140 W							
Number of on-load operations	10 ⁵ on AC15								
Number of off-load operations	10 x 10 ⁷								
Operation speed	F	5 ms	5 ms	5 ms	5 ms	5 ms	5 ms	6 ms	7 ms
	O	8 ms	8 ms	15 ms	15 ms	15 ms	15 ms	15 ms	15 ms
Insulation coil / contact	4000 V RMS								
Resistance to shock coil / contact	4000 V RMS								
Insulation contact / contact	1000 V RMS								
Ambient temperature	storage	-40 °C to -80 °C							
	operating	See derating curves							

Other characteristics

Body material	grey	UL 94 V0
Wire size	Solid wire	0.2 - 4 mm ² (24-12 AWG)
	Stranded wire	0.22 - 2.5 mm ² (24-12 AWG)
Rated wire size	2.5 mm ² (12 AWG)	
Wire stripping length	10 mm (0.394 in)	
Recommended screwdriver	3.5 mm (0.137 in)	
Protection	IP20 NEMA1	
Recommended torque	0.4-0.6 Nm (3.5-5.3 lb.in)	
Approvals	cULus (pending) , CE	
Reference standards	CEI 947-7-1 / CEI 947-1 / CEI 1131-2 (in relevant parts) / CEI 60664-1 / CEM : IEC 1000-4-2, 3, 4, 5, 6.	

	DC12	AC12	DC13	AC15
24 V	6 A	6 A	1 A	3 A
110/120 V	0,3 A	6 A	0,2 A	3 A
220/230 V	0,2 A	6 A	0,1 A	3 A

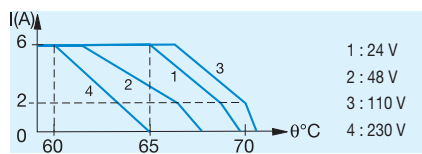
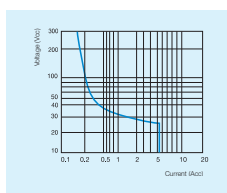

D 2,5/5-R121

Dimensional drawings

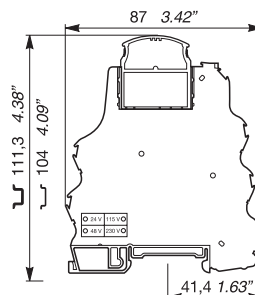

Optocouplers R500 range

Product group picture

5

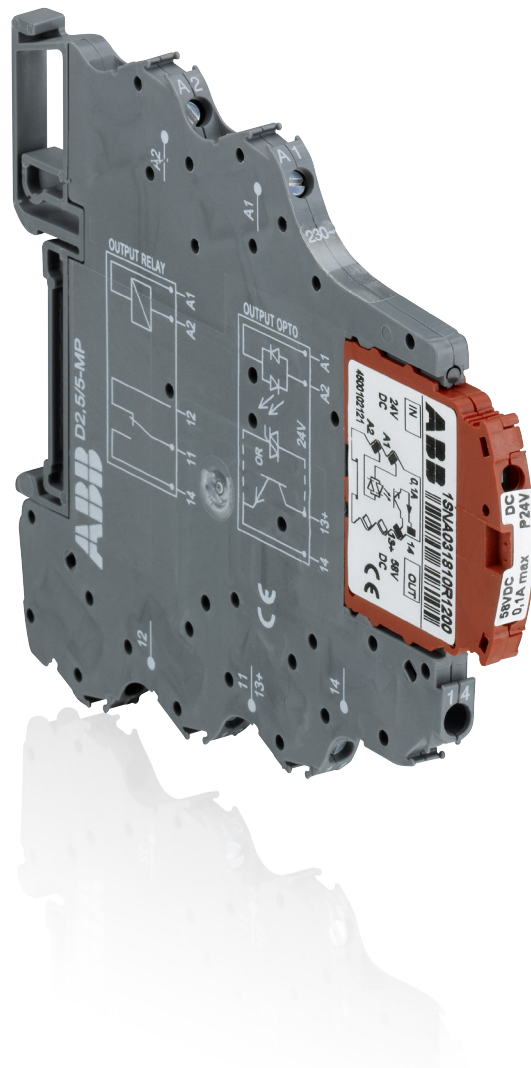

Optocouplers R500 range

Table of contents

Optocouplers R500 range	
Product group picture	5/33
Table of contents	5/34
Selection	5/35
Ordering details	5/36
Connection diagrams	5/37
Technical data	5/38
Notes	5/44

Optocouplers R500 range Selection

Type	Order number
D 2,5/5-OBIC-0030-5VDC	1SNA 607 274 R1300
D 2,5/5-OBIC-0030-24VDC	1SNA 607 210 R1700
D 2,5/5-OBIC-0030-48VDC	1SNA 607 211 R0400
D 2,5/5-OBIC-0030-125VDC	1SNA 607 275 R1400
D 2,5/5-OBIA-0030-24VAC	1SNA 607 212 R0500
D 2,5/5-OBIA-0030-48VAC	1SNA 607 213 R0600
D 2,5/5-OBIA-0030-115VAC	1SNA 607 214 R0700
D 2,5/5-OBIA-0030-230VAC	1SNA 607 215 R0000
D 2,5/5-OBOC-0100-5VDC	1SNA 607 203 R1500
D 2,5/5-OBOC-0100-24VDC	1SNA 607 204 R1600
D 2,5/5-OBOC-0100-48VDC	1SNA 607 205 R1700
D 2,5/5-OBOC-1000-5VDC	1SNA 607 206 R1000
D 2,5/5-OBOC-1000-24VDC	1SNA 607 207 R1100
D 2,5/5-OBOC-1000-24VAC/DC	1SNA 607 250 R2700
D 2,5/5-OBOC-1000-48VAC/DC	1SNA 607 251 R1400
D 2,5/5-OBOC-1000-110VAC	1SNA 607 270 R2300
D 2,5/5-OBOC-1000-230VAC	1SNA 607 271 R1000
D 2,5/5-OBOC-2000-5VDC	1SNA 607 208 R2200
D 2,5/5-OBOC-2000-24VDC	1SNA 607 209 R2300
D 2,5/5-OBOC-2000-24VAC/DC	1SNA 607 255 R1000
D 2,5/5-OBOC-2000-48VAC/DC	1SNA 607 256 R1100
D 2,5/5-OBOC-2000-110VAC	1SNA 607 272 R1100
D 2,5/5-OBOC-2000-230VAC	1SNA 607 273 R1200
D 2,5/5-OB0A-1000-24VDC	1SNA 607 238 R1700
D 2,5/5-OB0A-1000-24VAC/DC	1SNA 607 240 R2500
D 2,5/5-OB0A-1000-48VAC/DC	1SNA 607 241 R1200
D 2,5/5-OB0A-1000-110VAC	1SNA 607 268 R2500
D 2,5/5-OB0A-1000-230VAC	1SNA 607 269 R2600

Input voltage	
5 V DC	■
24 V DC	■
48 V DC	■
125 V DC	■
24 V AC	■
48 V AC	■
110 V AC	■
115 V AC	■
230 V AC	■

Output rating	
30 mA	■
100 mA	■
2 A	■
1 A	■

Output voltage	
30 V DC	■
58 V DC	■
253 V AC	■

Type	
input optocoupler	■
output optocoupler	■

Optocouplers R500 range

Ordering details

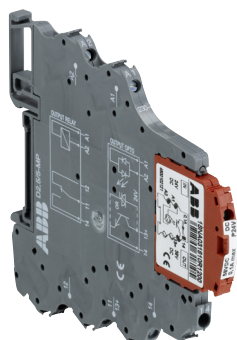

2CDC291 002 F0013

Description of R600 Optocoupler	Type	Order code	Price	Pkg qty	Weight (1 pce) kg (lb)
Optocoupler module 30 mA/DC Transistor	D 2,5/5-OBIC-0030-5VDC	1SNA607274R1300		1	0.032 (0.071)
	D 2,5/5-OBIC-0030-24VDC	1SNA607210R1700			
	D 2,5/5-OBIC-0030-48VDC	1SNA607211R0400			
Optocoupler module 30 mA/DC Transistor	D 2,5/5-OBIC-0030-125VDC	1SNA607275R1400		1	0.032 (0.071)
	D 2,5/5-OBIA-0030-24VAC	1SNA607212R0500			
	D 2,5/5-OBIA-0030-48VAC	1SNA607213R0600			
	D 2,5/5-OBIA-0030-115VAC	1SNA607214R0700			
Optocoupler module 100 mA/DC Transistor	D 2,5/5-OBIA-0030-230VAC	1SNA607215R0000		1	0.032 (0.071)
	D 2,5/5-OBOC-0100-5VAC	1SNA607203R1500			
	D 2,5/5-OBOC-0100-24VDC	1SNA607204R1600			
Optocoupler module 1 A/DC MOS-FET	D 2,5/5-OBOC-0100-48VAC	1SNA607205R1700		1	0.04 (0.088)
	D 2,5/5-OBOC-1000-5VDC	1SNA607206R1000			
	D 2,5/5-OBOC-1000-24VDC	1SNA607207R1100			
	D 2,5/5-OBOC-1000-24VAC/DC	1SNA607250R2700			
	D 2,5/5-OBOC-1000-48VAC/DC	1SNA607251R1400			
Optocoupler module 2 A/DC MOS-FET	D 2,5/5-OBOC-1000-110VAC	1SNA607270R2300		1	0.04 (0.088)
	D 2,5/5-OBOC-1000-230VAC	1SNA607271R1000			
	D 2,5/5-OBOC-2000-5VDC	1SNA607208R2200			
	D 2,5/5-OBOC-2000-24VDC	1SNA607209R2300			
Optocoupler module 1 A/AC Thyristor	D 2,5/5-OBOC-2000-24VAC/DC	1SNA607255R1000		1	0.04 (0.088)
	D 2,5/5-OBOC-2000-48VAC/DC	1SNA607256R1100			
	D 2,5/5-OBOC-2000-110VAC	1SNA607272R1100			
	D 2,5/5-OBOC-2000-230VAC	1SNA607273R1200			
	D 2,5/5-OBOA-1000-24VDC	1SNA607238R1700			
Optocoupler module 1 A/AC Thyristor	D 2,5/5-OBOA-1000-24VAC/DC	1SNA607240R2500		1	0.04 (0.088)
	D 2,5/5-OBOA-1000-48VAC/DC	1SNA607241R1200			
	D 2,5/5-OBOA-1000-110VAC	1SNA607268R2500			
	D 2,5/5-OBOA-1000-230VAC	1SNA607269R2600			

5

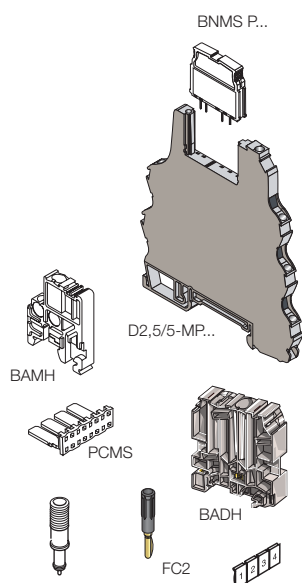

Description of Accessories	Type	Order code	Price	Pkg qty	Weight (1 pce) kg (lb)
High end stop	BAMH 9.1 mm	1SNA114836R0000		50	
	BAMH V0 9.1 mm	1SNA194836R0100			
	BADH 12 mm	1SNA116900R2700			
Comb type jumper bar 2 to 22 poles		consult us			
Jumper bar 10 poles grey	PCMS V0	1SNA205523R2200		8	
Input opto base	D 2.5-5-MP1	1SNA607223R0000		10	0.028 (0.062)
Plug OBIC 5 V white	BNMS T5V-1	1SNA031831R0300		4	
Plug OBIC 24 V white	BNMS T24V-1	1SNA031800R2100			
Plug OBIC 48 V white	BNMS T48V-1	1SNA031801R1600			
Plug OBIC 125 V white	BNMS T125V-1	1SNA031845R1100			
Test device blue	DCB (1)	1SNA105028R2100		10	
Test plug DIA 2 mm	FC2	1SNA105028R2100			
Marking method	RC55	see marking			

Optocouplers R500 range

Connection diagrams

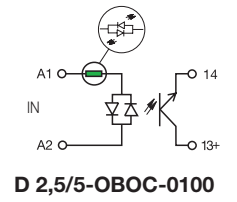
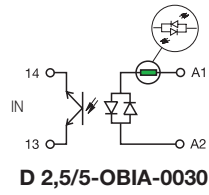
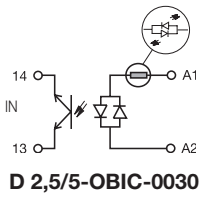

5

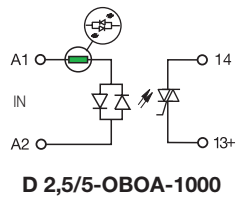
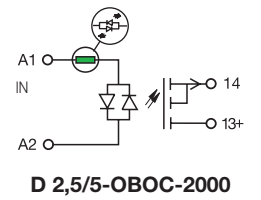
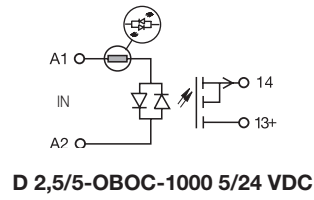
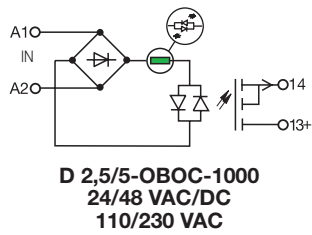

Optocouplers R500 range

Technical data

Technical data

Pluggable optocoupler : 5 to 58 V DC output / 30 mA - 5.08 mm 0.200" spacing

		D 2,5/5-OBIC-0030			
Input					
Input voltage		4.5 V to 5.5 VDC	19.2 V to 27.6 VDC	38.4 V to 55.2 VDC	93.5 V to 140 VDC
Input current		6 mA	5 mA	4.1 mA	3 mA
Pull-in voltage at Is=100%		3.5 V	12 V	21 V	50 V
Switching time C / O		20 μ s / 1.3 ms			
Operating frequency		400 Hz			
Permissible leakage current			1 mA	0.8 mA	
Output					
Output voltage		4.5 to 58 V DC			
Output current min.		0.5 mA			
Output current max.		30 mA			
Output leakage current at U _{max}		< 50 μ A			
Redidual voltage at I max and U rated	typical	2.3 V DC			
	max	2.7 V DC			
Frequency on inductive load					
Isolation Input / Output	input / Output	2500 V RMS			
Ambient temperature	storage	-40...+80 °C			
	operating	See derating curve			
Other characteristics					
Body material	grey	UL 94 V0			
Wire size	Solid wire	0.2 - 4 mm ² (24-12 AWG)			
	Stranded wire	0.22 - 2.5 mm ² (24-12 AWG)			
Rated wire size		2.5 mm ² (12 AWG)			
Wire stripping length		9 mm (0.354 in)			
Recommended screwdriver		3.5 mm (0.137 in)			
Protection		IP20 NEMA1			
Recommended torque		0.4-0.6 Nm (3.5-5.3 lb.in)			
Approvals		UL us (pending), CE			
Reference standards		CEI 947-1 / CEI 947-1 / CEI 1131-2 (in relevant parts) / CEI 60664-1 / CEM : IEC 1000-4-2, 3, 4, 5, 6.			

5

Derating curve

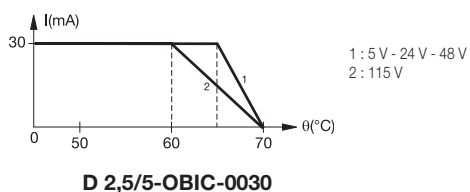

Dimensional drawings

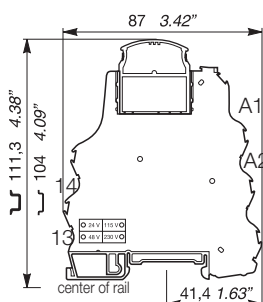

Optocouplers R500 range

Technical data

Technical data

Pluggable optocoupler : 5 to 58 V DC output / 30 mA - 5.08 mm 0.200" spacing

D 2,5/5-OBIA-0030

Input				
Input voltage	20.4 to 26.4 V AC	40.8 V to 52.8 V AC	98 V to 126.5 V AC	195.5 V to 253 V AC
Input current	8.5 mA	4.5 mA	8 mA	7 mA
Pull-in voltage at Is=100%	13 V	22 V	50 V	95 V
Switching time C / O	6 ms / 10 ms			
Operating frequency	30 Hz			
Permissible leakage current	1 mA	2 mA		

Output	
Output voltage	4.5 V to 58 V DC
Output current min.	0.5 mA
Output current max.	30 mA
Output leakage current at U_{max}	< 50 μ A
Residual voltage at I max and U rated	typical
	max
Frequency on inductive load	2500 V RMS
Isolation Input / Output	input / Output

Temperature	
Ambient temperature	storage
	operating

Other characteristics	
Body material	grey
Wire size	Solid wire
	Stranded wire
Rated wire size	
Wire stripping length	
Recommended screwdriver	
Protection	
Recommended torque	
Approvals	
Reference standards	

Derating curve

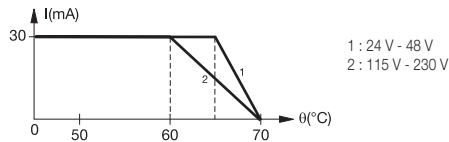

D 2,5/5-OBIA-0030

Dimensional drawings

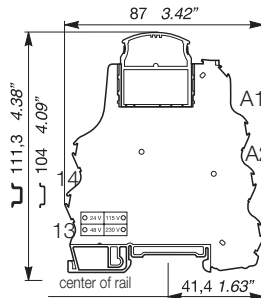



Optocouplers R500 range

Technical data

Technical data

Pluggable optocoupler : 5 to 58 V DC output / 100 mA - 5.08 mm 0.200" spacing

	D 2,5/5-OBOC-0100 5 V DC / 24 V DC		D 2,5/5-OBOC-0100 48 V DC
Input			
Input voltage	4.5 V to 5.5 V DC	20.4 V to 28.8 V DC	40.8 V to 57.6 V DC
Frequency			
Input current	8.5 mA	4.8 mA	3.9 mA
Pull-in voltage at Is=100%	2.9 V DC	16 V DC	26 V DC
Switching time C / O	20 µs / 1.3 ms		
Operating frequency	400 Hz		
Permissible leakage current	1 mA		
Output			
Output voltage	4.5 V to 58 V DC		
Output current min.	1 mA		
Output current max.	100 mA		
Output leakage current at U _{rmax}	< 50 µA		
Redidual voltage at I max and U rated	typical	1 V DC	
	max	1.3 V DC	
Frequency on inductive load	See Note 1		
Isolation Input / Output	input / Output	2500 V RMS	
Temperature			
Ambient temperature	storage	-40...+80 °C	
	operating	See derating curve	
Other characteristics			
Body material	grey	UL 94 V0	
Wire size	Solid wire	0.2 - 4 mm ² (24-12 AWG)	
	Stranded wire	0.22 - 2.5 mm ² (24-12 AWG)	
Rated wire size		2.5 mm ² (12 AWG)	
Wire stripping length		9 mm (0.354 in)	
Recommended screwdriver		3.5 mm (0.137 in)	
Protection		IP20 NEMA1	
Recommended torque		0.4-0.6 Nm (3.5-5.3 lb.in)	
Approvals		c  us (pending), 	
Reference standards		CEI 947-7-1 / CEI 947-1 / CEI 1131-2 (in relevant parts) / CEI 60664-1 / CEM : IEC 1000-4-2, 3, 4, 5, 6.	

Note 1 :

$$F_{max} = (1 - 0,007 \times U_s) / (L \times I_s^2)$$

or

$$F_{max} = (1 - 0,007 \times U_s) / (P \times \frac{L}{R})$$

- U_s = Output voltage
- I_s = Output current
- L = Inductance of load
- P = Power of load
- R = Resistance of load

Derating curve

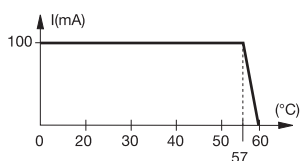

D 2,5/5-OBOC-0100 5 V DC / 24 V DC

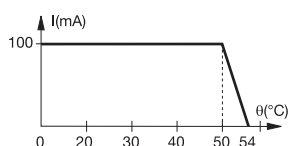

D 2,5/5-OBOC-0100 48 V DC

Dimensional drawings

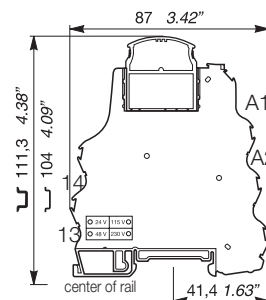

Optocouplers R500 range

Technical data

Technical data

Pluggable optocoupler : 5 to 58 V DC output / 1 A - 5.08 mm 0.200" spacing

	D 2,5/5-OBOC-1000 5/24 V DC		D 2,5/5-OBOC-1000 24/48 V AC/DC				D 2,5/5-OBOC-1000 110/230 V AC	
	5 V DC	24 V DC	24 V AC	24 V DC	48 V AC	48 V DC	110 V AC	230 V AC
Input								
Input voltage	4.5 - 5.5 V DC	20.4 - 28.8 V DC	24 ± 10 %	20.4 - 28.8 V DC	48 ± 10 %	40.8 to 57.6 V DC	110 ± 10 %	230 ± 10 %
Frequency			50 / 60 Hz		50 / 60 Hz		50 / 60 Hz	50 / 60 Hz
Input current	12.3 mA	6.7 mA	10.5 mA	8 mA	6.8 mA	5.8 mA	8.5 mA	7.5 mA
Pull-in voltage at Is=100%	3.5 V DC	10 V DC						
Switching time C / O	20 / 250 µs	50 / 350 µs	15 / 13 ms	5 / 13 ms	15 / 15 ms	6 / 25 ms	15 / 15 ms	15 / 15 ms
Operating frequency	2000 Hz	1500 Hz	20 Hz					
Permissible leakage current								
Output								
Output voltage	4.5 V to 58 V DC							
Output current min.	1 mA							
Output current max.	1 A							
Output leakage current at U _{max}	< 50 µA							
Residual voltage at I _{max} and U _{rated}	typical	0.1 V DC						
	max	0.5 V DC						
Frequency on inductive load	See Note 1							
Isolation Input / Output	input / Output	2500 V RMS						
Temperature								
Ambient temperature	storage	-40...+80 °C						
	operating	See derating curve						
Other characteristics								
Body material	grey	UL 94 V0						
Wire size	Solid wire	0.2 - 4 mm ² (24-12 AWG)						
	Stranded wire	0.22 - 2.5 mm ² (24-12 AWG)						
Rated wire size		2.5 mm ² (12 AWG)						
Wire stripping length		10 mm (0.394 in)						
Recommended screwdriver		3.5 mm (0.137 in)						
Protection		IP20 NEMA1						
Recommended torque		0.4-0.6 Nm (3.5-5.3 lb.in)						
Approvals		cULus (pending), CE						
Reference standards		CEI 947-7-1 / CEI 947-1 / CEI 1131-2 (in relevant parts) / CEI 60664-1 / CEM : IEC 1000-4-2, 3, 4, 5, 6.						

Note 1 :

$$I_{max} = (1 - 0,007 \times U_s) / (L \times I_s^2)$$

or

$$I_{max} = (1 - 0,007 \times U_s) / (P \times \frac{L}{R})$$

U_s = Output voltage
I_s = Output current
L = Inductance of load
P = Power of load
R = Resistance of load

Derating curve

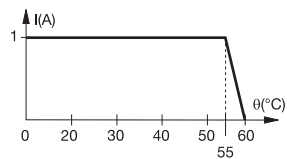

Dimensional drawings

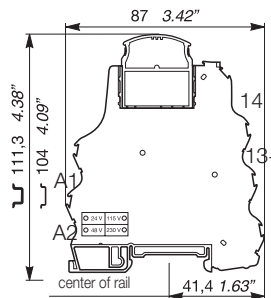

Optocouplers R500 range

Technical data

Technical data

Pluggable optocoupler : 5 to 30 V DC output / 2 A - 5.08 mm 0.200" spacing

	D 2,5/5-OB0C-2000 5/24 V DC		D 2,5/5-OB0C-2000 24/48 V AC/DC				D 2,5/5-OB0C-2000 110/230 V AC	
Input	5 V DC	24 V DC	24 V AC	24 V DC	48 V AC	48 V DC	110 V AC	230 V AC
Input voltage	4.5 - 5.5 V DC	20.4 - 28.8 V DC	24 ± 10 %	20.4 - 28.8 V DC	48 ± 10 %	40.8 to 57.6 V DC	110 ± 10 %	230 ± 10 %
Frequency			50 / 60 Hz		50 / 60 Hz		50 / 60 Hz	50 / 60 Hz
Input current	12.3 mA	6.7 mA	10.5 mA	8 mA	6.8 mA	5.8 mA	8.5 mA	7.5 mA
Pull-in voltage at Is=100%	3.5 V DC	10 V DC						
Switching time C / O	20 / 250 µs	50 / 350 µs	15 / 13 ms	5 / 13 ms	15 / 15 ms	6 / 25 ms	15 / 15 ms	15 / 15 ms
Operating frequency	2000 Hz	1500 Hz	20 Hz					
Permissible leakage current								
Output								
Output voltage	4.5 V to 30 V DC							
Output current min.	1 mA							
Output current max.	2 A							
Output leakage current at U _{max}	< 50 µA							
Residual voltage at I max and U rated	typical	0.1 V DC						
	max	0.5 V DC						
Frequency on inductive load	See Note 1							
Isolation Input / Output	input / Output	2500 V RMS						
Temperature								
Ambient temperature	storage	-40...+80 °C						
	operating	See derating curve						
Other characteristics								
Body material	grey	UL 94 V0						
Wire size	Solid wire	0.2 - 4 mm ² (24-12 AWG)						
	Stranded wire	0.22 - 2.5 mm ² (24-12 AWG)						
Rated wire size		2.5 mm ² (12 AWG)						
Wire stripping length		10 mm (0.394 in)						
Recommended screwdriver		3.5 mm (0.137 in)						
Protection		IP20 NEMA1						
Recommended torque		0.4-0.6 Nm (3.5-5.3 lb.in)						
Approvals		c us (pending),						
Reference standards		CEI 947-1 / CEI 947-1 / CEI 1131-2 (in relevant parts) / CEI 60664-1 / CEM : IEC 1000-4-2, 3, 4, 5, 6.						

5

Note 1 :

$$F_{max} = (1 - 0,012 \times U_s) / (L \times I_s^2)$$

or

$$F_{max} = (1 - 0,012 \times U_s) / (P \times \frac{L}{R})$$

U_s = Output voltage
I_s = Output current
L = Inductance of load
P = Power of load
R = Resistance of load

Derating curve

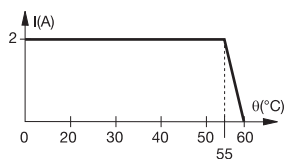

Dimensional drawings

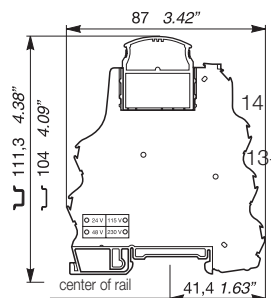

Optocouplers R500 range

Technical data

Technical data

Pluggable optocoupler : 24 to 253 V AC output / 1 A - 5.08 mm 0.200" spacing

	D 2,5/5-... 24 V DC	D 2,5/5-OBOA-1000 24 V AC/DC - 48 V AC/DC				D 2,5/5-OBOA-1000 110 V AC - 230 V AC	
Input	24 V DC	24 V AC	24 V DC	48 V AC	48 V DC	110 V AC	230 V AC
Input voltage	20.4 - 28.8 V DC	24 ± 10 %	20.6 - 28.8 V DC	48 ± 10 %	40.8 - 57.6 V DC	110 ± 10 %	230 ± 10 %
Frequency		50 / 60 Hz		50 / 60 Hz		50 / 60 Hz	50 / 60 Hz
Input current	4 mA	10 mA	7 mA	6 mA	5 mA	8 mA	7.5 mA
Pull-in voltage at Is=100%							
Switching time C / O	10/20 ms	20/20 ms	10/20 ms	20/20 ms	10/20 ms	20/20 ms	20/20 ms
Operating frequency	15 Hz						
Permissible leakage current							
Output	24-253 V AC - 50/60 Hz						
Output voltage	24-253 V AC - 50/60 Hz						
Output current min.	25 mA						
Output current max.	1 A						
Output leakage current at U _{max}	< 0.50 mA						
Residual voltage at I max and U rated	typical	1 V					
	max	1.6 V					
Frequency on inductive load	See Note 1						
Isolation Input / Output	input / Output	2500 V RMS					
Temperature							
Ambient temperature	storage	-40...+80 °C					
	operating	See derating curve					
Other characteristics							
Body material	grey	UL 94 V0					
Wire size	Solid wire	0.2 - 4 mm ² (24-12 AWG)					
	Stranded wire	0.22 - 2.5 mm ² (24-12 AWG)					
Rated wire size		2.5 mm ² (12 AWG)					
Wire stripping length		10 mm (0.394 in)					
Recommended screwdriver		3.5 mm (0.137 in)					
Protection		IP20 NEMA1					
Recommended torque		0.4-0.6 Nm (3.5-5.3 lb.in)					
Approvals		cULus (pending), CE					
Reference standards		CEI 947-7-1 / CEI 947-1 / CEI 1131-2 (in relevant parts) / CEI 60664-1 / CEM : IEC 1000-4-2, 3, 4, 5, 6.					

Note 1 :

$$F_{max} = (1 - 0,012 \times U_s) / (L \times I_s^2)$$

or

$$F_{max} = (1 - 0,012 \times U_s) / (P \times \frac{L}{R})$$

U_s = Output voltage
I_s = Output current
L = Inductance of load
P = Power of load
R = Resistance of load

Derating curve

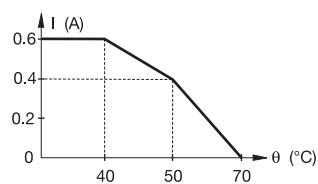

Dimensional drawings

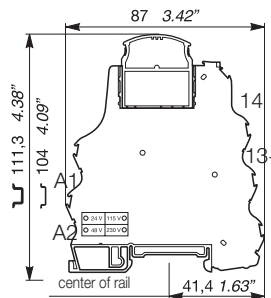

Optocouplers R500 range

Notes

A large area of the page is filled with horizontal dotted lines, serving as a template for handwritten notes.

Interface relays and optocouplers R600 range

Product group picture

5

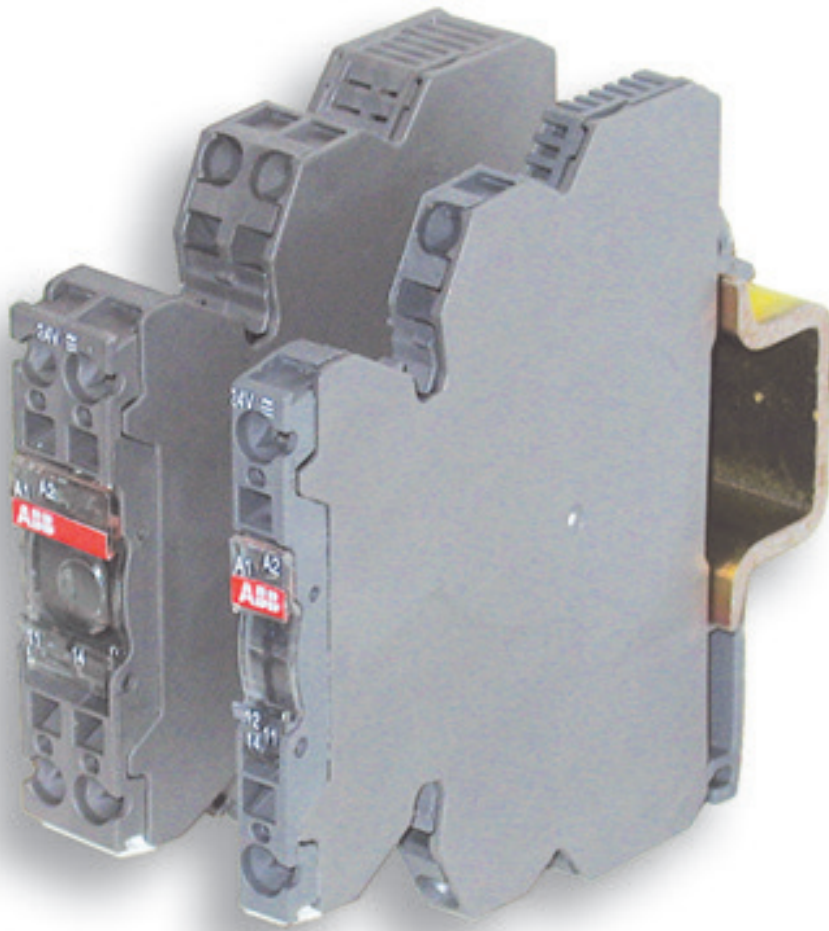

Interface relays and optocouplers R600 range

Table of contents

Interface relays and optocouplers R600 range	
Product group picture	5/45
Table of contents	5/46
Interface relays R600 range	5/47
Product group picture	5/47
Table of contents	5/48
Benefits and advantages	5/49
Selection	5/51
Ordering details	5/53
Connection diagrams	5/55
Technical data	5/56
General technical data	5/61
Dimensional drawings, Load limit curves	5/62
Optocouplers R600 range	5/63
Product group picture	5/63
Table of contents	5/64
Selection	5/65
Ordering details	5/67
Connection diagrams	5/68
Technical data	5/69

Interface relays R600 range
Product group picture

5

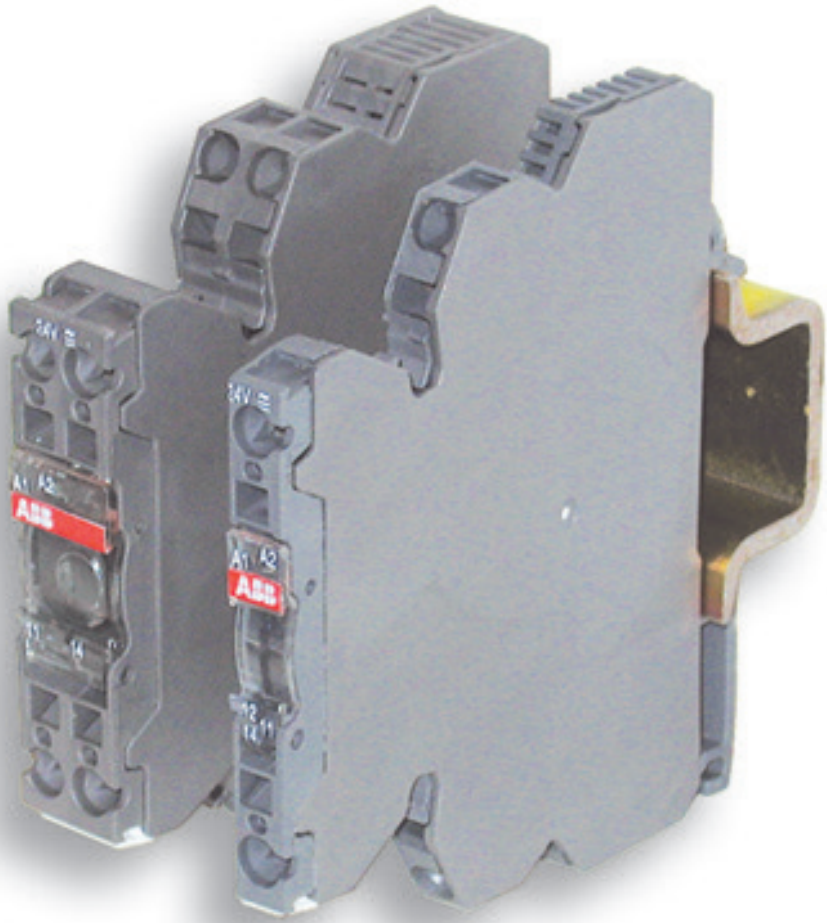

Interface relays R600 range

Table of contents

Interface relays R600 range	
Product group picture	5/47
Table of contents	5/48
Benefits and advantages	5/49
Selection	5/51
Ordering details	5/53
Connection diagrams	5/55
Technical data	5/56
General technical data	5/61
Dimensional drawings, Load limit curves	5/62

Interface relays R600 range

Benefits and advantages

Characteristics

- Standard range available with screw or spring-type terminals
- 8 different rated control supply voltages:
DC versions: 5 V, 12 V, 24 V
AC/DC versions: 24 V, 48-60 V, 115 V, 230 V, 60-230 V
- Output: 1 n/c contact, 1 n/o contact, 1 c/o (SPDT) contact, 2 c/o (SPDT) contacts
- Devices with output contacts protected by built in RC circuit, which result in increased contact life
- Devices with leakage current protection on the input side
- Available with visible or covered switch on the front of the unit, for the configuration of manual or automatic actuation
- With connection for jumper bar, except 2 c/o devices and some discontinued devices
- Width: 6 mm (0.236 in) or 12 mm (0.472 in)
- LED for the indication of the operational state
- Accessories: Jumper bars, separator end section and distribution blocks

5

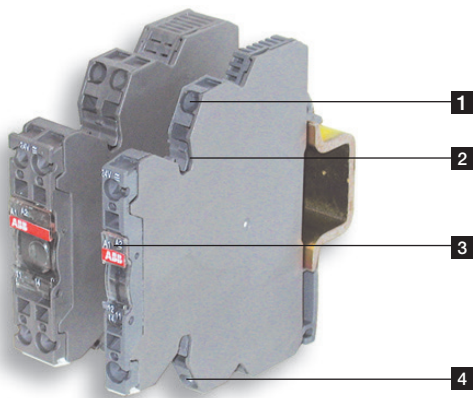

- 1** Input - Control supply voltage
- 2** Jumper bar connection
- 3** Indication of operational states (green LED)
- 4** Output

Excellent adaption and conversion of digital signals

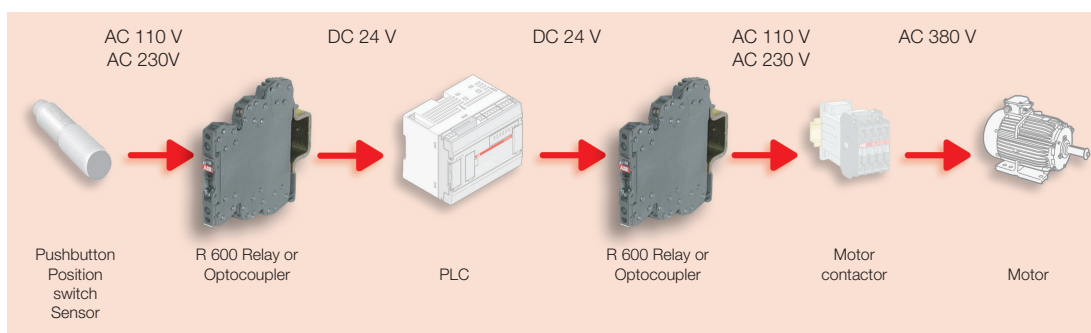

Interface relays R600 range

Benefits and advantages

Interface relays are electromechanic and electronic input and output modules for electrical isolation, levelling, noise suppression or signal amplification between control unit and process.

Boxed interface relays are used for electrical isolation, amplification and signal matching between the electronic controlling, e.g. PLC (programmable logic controller), PC or field bus systems and the sensor / actuator level. The compact design and different connection terminal possibilities optimize your panel installation.

Increased contact life

The contacts of some devices are protected by built in RC-circuits which result in increased contact life.

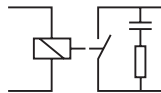

Variety of connections

R600 relays and optocouplers are available with both screw terminals or spring terminals.

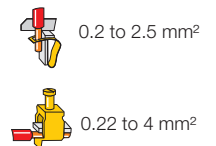

Space saving

With a width of only 6 mm or 12 mm the compact design saves space in each cabinet.

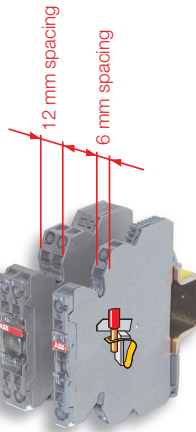

Functioning status

Functioning display through a green LED.



Only one part number AC/DC

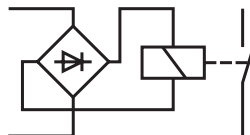

Measurement & Test

Holes for holding DIA. 2 mm test plugs to simplify any measury or test.



Approvals

 UL 508
CAN/CSA C22.2 No.14

 Lloyds Register

pending

Marks

 CE

Interface relays R600 range

Selection

Type	Order number
RB 121-5VDC	1SNA 645 034 R2300
RB 121-5VDC	1SNA 645 036 R2500
RBR 121-5VDC	1SNA 645 534 R2500
RBR 121-5VDC	1SNA 645 536 R2700
RB 121-12VDC	1SNA 645 069 R0000
RB 121-12VDC	1SNA 645 037 R2600
RBR 121-12VDC	1SNA 645 537 R2000
RB 101AR-24VAC/DC	1SNA 645 019 R0400
RBR 101AR-24VAC/DC	1SNA 645 519 R0600
RB 111A-24VAC/DC	1SNA 645 014 R2700
RB 111AI-24VAC/DC	1SNA 645 063 R0000
RB 111AR-24VAC/DC	1SNA 645 018 R0300
RBR 111A-24VAC/DC	1SNA 645 514 R2100
RBR 111AI-24VAC/DC	1SNA 645 563 R0200
RBR 111AR-24VAC/DC	1SNA 645 518 R0500
RB 121-24VDC	1SNA 645 064 R0100
RB 121-24VDC	1SNA 645 065 R0200
RB 121A-24VAC/DC	1SNA 645 001 R0300
RB 121A-24VAC/DC	1SNA 645 005 R0700
RB 121AI-24VAC/DC	1SNA 645 032 R2100
RB 121AI-24VAC/DC	1SNA 645 009 R1300
RB 121AI-24VAC/DC	1SNA 645 033 R2200
RB 121AI-24VAC/DC	1SNA 645 010 R0700
RBR 121-24VDC	1SNA 645 564 R0300
RBR 121-24VDC	1SNA 645 565 R0400
RBR 121A-24VAC/DC	1SNA 645 501 R0500
RBR 121A-24VAC/DC	1SNA 645 505 R0100
RBR 121AI-24VAC/DC	1SNA 645 532 R2300
RBR 121AI-24VAC/DC	1SNA 645 509 R1500
RBR 121AI-24VAC/DC	1SNA 645 533 R2400
RBR 121AI-24VAC/DC	1SNA 645 510 R0100
RB 122A-24VAC/DC	1SNA 645 012 R2500
RBR 122A-24VAC/DC	1SNA 645 512 R2700

Input voltage																									
5 V DC	■	■	■	■																					
12 V DC					■	■	■																		
24 V DC								■	■	■	■	■	■	■	■	■	■	■	■	■	■	■	■	■	■
48 - 60 V DC																									
115 V DC																									
230 V DC																									
60 - 230 V DC																									
24 V AC								■	■	■	■	■	■	■	■	■	■	■	■	■	■	■	■	■	■
48 - 60 V AC																									
115 V AC																									
230 V AC																									
60 - 230 V AC																									

Output rating																									
10 mA - 6 A	■		■		■		■	■	■	■	■	■	■	■	■	■	■	■	■	■	■	■	■	■	■
1 mA - 6 A		■		■		■																			
1 mA - 8 A																									■

Output contacts																									
c/o	1	1	1	1	1	1	1																		
n/o																									
n/c								1	1																

Terminal type																									
Screw	■	■			■	■		■	■	■	■	■	■	■	■	■	■	■	■	■	■	■	■	■	■
Spring			■	■			■																		■

Interface relays R600 range

Ordering details



2CDC 291 024 50013

5

R600

R600 Relay	Type	Order code	Price	Pkg qty	Weight (1 pce) kg (lb)
Relay module 1 NO high level 6 mm spacing	RB 111 A-24VAC/DC	1SNA645014R2700		10	0.02 (0.44)
	RB 111 A-48-60VAC/DC	1SNA645015R2000			
	RB 111 A-115VAC/DC	1SNA645016R2100			
	RB 111 A-230VAC/DC	1SNA645017R2200			
Relay mod. 1 NO high level w/safety switch 6 mm spacing	RB 111 AI-24VAC/DC	1SNA645063R0000		5	0.03 (0.44)
Relay mod. 1 NO high level w/contact protection 12 mm spacing	RB 111 AR-24VAC/DC	1SNA645018R0300		5	0.03 (0.44)
Relay module 1 NO high level 6 mm spacing	RBR 111 A-24VAC/DC	1SNA645514R2100		10	0.02 (0.44)
	RBR 111 A-48-60VAC/DC	1SNA645515R2200			
	RBR 111 A-115VAC/DC	1SNA645516R2300			
	RBR 111 A-230VAC/DC	1SNA645517R2400			
Relay mod. 1 NO high level w/safety switch 6 mm spacing	RBR 111 AI-24VAC/DC	1SNA645563R0200		5	0.03 (0.44)
Relay mod. 1 NO high level w/contact protection 12 mm spacing	RBR 111 AR-24VAC/DC	1SNA645518R0500		5	0.03 (0.44)
Relay mod. 1 NC high level w/contact protection 12 mm spacing	RBR 101 AR-24VAC/DC	1SNA645519R0600			
Relay module 1 SPDT high level	RB 121-5VDC	1SNA645034R2300		10	0.02 (0.44)
	RB 121-12VDC	1SNA645069R0100			
	RB 121-24VDC	1SNA645064R0100			
	RB 121 A-24VAC/DC	1SNA645001R0300			
	RB 121 A-48-60VAC/DC	1SNA645002R0400			
	RB 121 A-115VAC/DC	1SNA645003R0500			
Relay module 1 SPDT high level	RB 121 A-230VAC/DC	1SNA645004R0400		10	0.02 (0.44)
	RB 121-5VDC	1SNA645534R2500			
	RB 121-12VDC	1SNA645569R0000			
	RB 121-24VDC	1SNA645564R0300			
	RB 121 A-24VAC/DC	1SNA645501R0500			
	RB 121 A-48-60VAC/DC	1SNA645502R0600			
Relay module 1 SPDT low level	RB 121 A-115VAC/DC	1SNA645503R0700		10	0.02 (0.44)
	RB 121 A-230VAC/DC	1SNA645504R0000			
	RB 121-5VDC	1SNA645036R2500			
	RB 121-12VDC	1SNA645037R2600			
	RB 121-24VDC	1SNA645065R0200			
	RB 121 A-24VAC/DC	1SNA645005R0700			
Relay module 1 SPDT low level	RB 121 A-48-60VAC/DC	1SNA645006R0000		10	0.02 (0.44)
	RB 121 A-115VAC/DC	1SNA645007R0100			
	RB 121 A-230VAC/DC	1SNA645008R1200			
	RB 121-5VDC	1SNA645536R2700			
	RB 121-12VDC	1SNA645537R2000			
	RB 121-24VDC	1SNA645565R0400			
Relay module 1 SPDT low level	RB 121 A-24VAC/DC	1SNA645505R0100		10	0.02 (0.44)
	RB 121 A-48-60VAC/DC	1SNA645506R0200			
	RB 121 A-115VAC/DC	1SNA645507R0300			
	RB 121 A-230VAC/DC	1SNA645508R1400			

Interface relays R600 range

Ordering details



R600

R600 Relay	Type	Order code	Price	Pkg qty	Weight (1 pce) kg (lb)
Relay mod. 1SPDT high level w/ leakage current protec.	RB 121 AR-115VAC/DC	1SNA645046R0700		5	0.03 (0.066)
	RB 121 AR-230VAC/DC	1SNA645011R2400			
Relay mod. 1SPDT high level w/ large coil voltage range	RB 121 A 60-230VAC/DC	1SNA645020R0100			
	RB 121 AI-24VAC/DC	1SNA645032R2100			
Relay mod. 1SPDT high level with switch	RB 121 AI-24VAC/DC	1SNA645009R1300			
Relay mod. 1SPDT high level with safety switch	RB 121 AI-24VAC/DC	1SNA645009R1300			
Relay module 1SPDT low level with switch	RB 121 AI-24VAC/DC	1SNA645033R2200			
Relay module 1SPDT low level with safety switch	RB 121 AI-24VAC/DC	1SNA645010R0700			
Relay mod. 1SPDT high level w/ leakage current protec.	RB 121 AR-115VAC/DC	1SNA645546R0100			
	RB 121 AR-230VAC/DC	1SNA645511R2600			
Relay mod. 1SPDT high level w/ large coil voltage range	RB 121 A 60-230VAC/DC	1SNA645520R0300			
	RB 121 AI-24VAC/DC	1SNA645532R2300			
Relay mod. 1SPDT high level with switch	RB 121 AI-24VAC/DC	1SNA645509R1500			
Relay mod. 1SPDT high level with safety switch	RB 121 AI-24VAC/DC	1SNA645509R1500			
Relay module 1SPDT low level with switch	RB 121 AI-24VAC/DC	1SNA645533R2400			
Relay module 1SPDT low level with safety switch	RB 121 AI-24VAC/DC	1SNA645510R0100			
Relay module 1 DPDT low level	RB 122 A-24VAC/DC	1SNA645012R2500			
	RB 122 A-48-60VAC/DC	1SNA645040R1500			
	RB 122 A-115VAC/DC	1SNA645041R0200			
	RB 122 A-230VAC/DC	1SNA645013R2600			
Relay module 1 DPDT low level	RBR 122 A-24VAC/DC	1SNA645512R2700			
	RBR 122 A-48-60VAC/DC	1SNA645540R1700			
	RBR 122 A-115VAC/DC	1SNA645541R0400			
	RBR 122 A-230VAC/DC	1SNA645513R2000			

Accessories R600	Type	Order code	Price	Pkg qty	Weight (1 pce) kg (lb)
End section	BADH V0	1SNA116900R2700		50	
	BADL V0	1SNA399903R0200		50	
	BAM2 V0	1SNA399967R0100		50	
Seperator end section	SC 612	1SNA290474R0200		10	
Divisible shunt 10 poles	BJ 612-10	1SNA290488R0100		10	
Divisible shunt 20 poles	BJ 612-20	1SNA206754R0000		10	
Screw clamp distribution block sp. 12 mm	D4/12-3-3	1SNA645031R2000		5	
Spring clamp distribution block sp. 12 mm	D4/12-3R-3R	1SNA645531R2200		5	
Test plug DIA. 2 mm	FC2	1SNA645531R2200		10	
Marking method	RC65 / RC610	see marking			

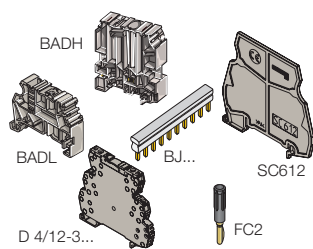

Interface relays R600 range

Connection diagrams

11-12 n/c contact
 13-14 n/o contact
 11-12/14 1st c/o contact
 21-22/24 2nd c/o contact

A1-A2 Control supply voltage
 S1 Connection for jumper bar (input side)
 S2 Connection for jumper bar (output side)

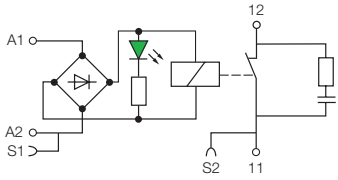

2CDC 292 030 F0013

RB/RBR 101 AR

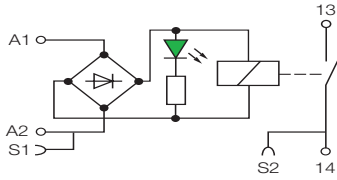

2CDC 292 031 F0013

RB/RBR 111 A - 24 V AC/DC

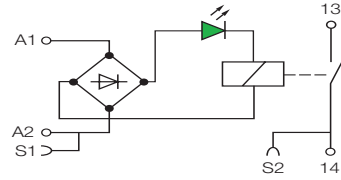

2CDC 292 033 F0013

RB/RBR 111 A - 48/60/115/230 V AC/DC

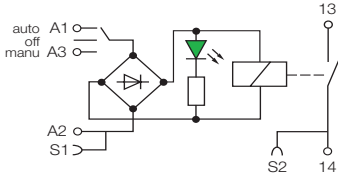

2CDC 292 034 F0013

RB/RBR 111 AI

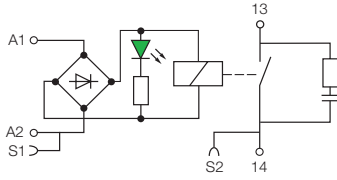

2CDC 292 035 F0013

RB/RBR 111 AR

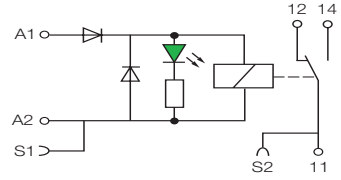

2CDC 292 036 F0013

RB/RBR 121
 - 5 V DC, A1-A2 polarized
 - 12 V DC, A1-A2 polarized, i.e. only:
 1SNA645035R2400, 1SNA645535R2600
 1SNA645037R2600, 1SNA645537R2000

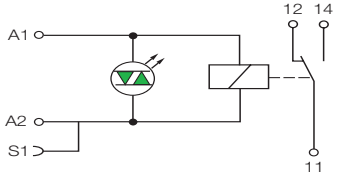

2CDC 292 037 F0013

RB/RBR 121
 - 12/24 V DC, only discontinued versions:
 1SNA645069R0000
 1SNA645064R0100, 1SNA645564R0300
 1SNA645065R0200, 1SNA645565R0400

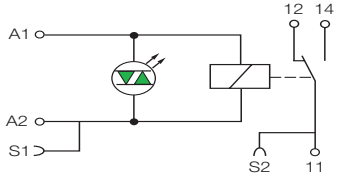

2CDC 292 038 F0013

RB/RBR 121 (AU)
 - 12/24 V DC, except:
 1SNA645035R2400, 1SNA645535R2600
 1SNA645037R2600, 1SNA645537R2000
 see connection diagram RB...121-5VDC

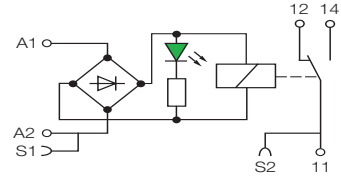

2CDC 292 039 F0013

RB/RBR 121 A
 - 24 V AC/DC

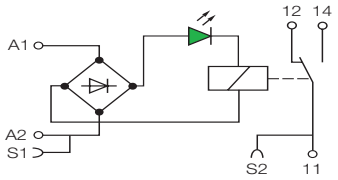

2CDC 292 040 F0013

RB/RBR 121 A - 48/60/115/230 V AC/DC

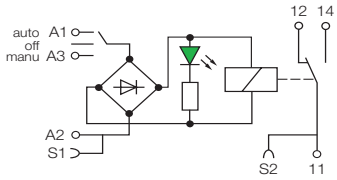

2CDC 292 041 F0013

RB/RBR 121 AI

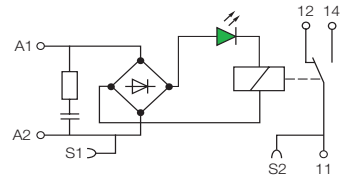

2CDC 292 042 F0013

RB/RBR 121 AR

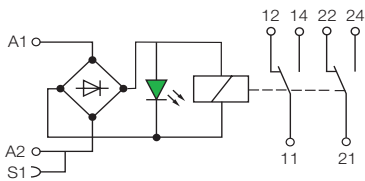

2CDC 292 043 F0013

RB/RB 122 A - 24/48/60 V AC/DC

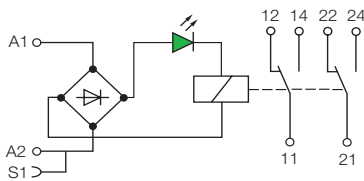

2CDC 292 044 F0013

RB/RBR 122 A - 115/230 V AC/DC

Interface relays R600 range

Technical data

Technical data

		RB 111 A				RB 111 AI	
Input circuit							
Rated control supply voltage U_s		24 V AC/DC	48 V AC/DC	60 V AC/DC	115 V AC/DC	230 V AC/DC	24 V AC/DC
Rated control supply voltage U_s tolerance	DC	-15 %, +20 %				-15 %, +10 %	-15 %, +20 %
	AC	-/+ 10 %					
Rated frequency		50/60 Hz					
Typical power consumption		0.24 W	0.34 W	0.54 W	0.46 W	0.8 W	0.24 W
Typical current		10 mA	7 mA	9 mA	4 mA	3.5 mA	10 mA
Drop-out		4.5 V	8 V	8 V	17 V	27 V	4.5 V
Indication of operational states	green LED	┌ ───┐ : control supply voltage applied					
Output circuit							
Kind of output	13-14	relay, 1 n/o contact					
Rated operational voltage U_a (IEC/EN 60947-1)		250 V AC					
Minimum switching voltage		12 V					
Maximum switching voltage		250 V AC					
Minimum switching current		10 mA					
Rated operational current (IEC/EN 60947-5-1)	AC12 (resistive) 230 V	6 A					
	AC15 (inductive) 230 V	1.5 A					
	AC15 (inductive) 120 V	3 A					
	DC12 (resistive) 24 V	6 A					
	DC13 (inductive) 24 V	1 A					
	DC13 (inductive) 120 V	0.2 A					
	DC13 (inductive) 230 V	0.1 A					
AC rating (UL 508; NEMA ICS-5)	Utilization category (pilot duty)	B300					
DC rating (UL 508; NEMA ICS-5)	Utilization category (pilot duty)	R300					
Minimum switching power		0.6 W / 0.6 VA					
Mechanical lifetime		1 x 10 ⁷ switching cycles					
Electrical lifetime	at AC15	1 x 10 ⁵ switching cycles					
Response time		5 ms	5 ms	5 ms	6 ms	7 ms	5 ms
Release time		8 ms	8 ms	8 ms	15 ms	15 ms	8 ms
Dimensions and weight		RB 111 A / RB 111 AI high level			RBR 111 A / RBR 111 AI high level		
Weight	net weight	0.02 kg (0.044 lb)					
Dimension	product dimension	6 x 75 x 75 mm (0.236 x 2.95 x 2.95 in)					
	packaging dimension						

Interface relays R600 range

Technical data

Technical data

		RB... 111AR high level	RB... 101AR high level
Input circuit			
Rated control supply voltage U_s		24 V AC/DC	
Rated control supply voltage U_s tolerance	DC	-15 %, +20 %	
	AC	-/+ 10 %	
Rated frequency		50/60 Hz	
Typical power consumption		0.24 W	
Typical current		10 mA	
Drop-out		4.5 V	
Indication of operational states	green LED	 : control supply voltage applied	
Output circuit			
Kind of output	11-12	-	relay, 1 n/c contact
	13-14	relay, 1 n/o contact	-
Rated operational voltage U_B (IEC/EN 60947-1)		250 V AC	
Minimum switching voltage		12 V	
Maximum switching voltage		250 V AC	
Minimum switching current		10 mA	
Rated operational current (IEC/EN 60947-5-1)	AC12 (resistive) 230 V	6 A	
	AC15 (inductive) 230 V	1.5 A	
	AC15 (inductive) 120 V	3 A	
	DC12 (resistive) 24 V	6 A	
	DC13 (inductive) 24 V	1 A	
	DC13 (inductive) 120 V	0.2 A	
	DC13 (inductive) 230 V	0.1 A	
AC rating (UL 508; NEMA ICS-5)	Utilization category (pilot duty)	B300	
DC rating (UL 508; NEMA ICS-5)	Utilization category (pilot duty)	R300	
Minimum switching power		0.6 W / 0.6 VA	
Mechanical lifetime		1 x 10 ⁷ switching cycles	
Electrical lifetime	at AC15	1 x 10 ⁸ switching cycles	
Response time		5 ms	
Release time		8 ms	
Dimensions and weight			
Weight	net weight	RB 111AR / RB 101AR high level	RBR 111A / RBR 111AR high level
Dimension	product dimension	12 x 70 x 75 mm (0.472 x 2.76 x 2.95 in)	
	packaging dimension	12 x 75 x 75 mm (0.472 x 2.95 x 2.95 in)	

5

Interface relays R600 range

Technical data

Technical data

		RB... 121 / RB... 121A high level							
Input circuit									
Rated control supply voltage U _s		5 V DC	12 V DC	24 V AC/DC	48 V AC/DC	60 V AC/DC	115 V AC/DC	230 V AC/DC	
Rated control supply voltage U _s tolerance	DC	-15 %, +20 %			-/+ 10 %		-15 %, +10 %		
	AC	-			50/60 Hz		-		
Rated frequency		-							
Typical power consumption		0.2 W	0.2 W	0.24 W	0.33 W	0.54 W	0.46 W	0.8 W	
Typical current		40 mA	16 mA	10 mA	7 mA	9 mA	4 mA	3.5 mA	
Drop-out		1.2 V	2.2 V	4.5 V	8 V	8 V	17 V	27 V	
Indication of operational states	green LED	┌: control supply voltage applied							
Output circuit									
Kind of output	11-12/14	relay, 1 c/o (SPDT) contact							
Rated operational voltage U _a (IEC/EN 60947-1)		250 V AC							
Minimum switching voltage		12 V							
Maximum switching voltage		250 V AC							
Minimum switching current		10 mA							
Rated operational current (IEC/EN 60947-5-1)	AC12 (resistive) 230 V	6 A							
	AC15 (inductive) 230 V	1.5 A							
	AC15 (inductive) 120 V	3 A							
	DC12 (resistive) 24 V	6 A							
	DC13 (inductive) 24 V	1 A							
	DC13 (inductive) 120 V	0.2 A							
	DC13 (inductive) 230 V	0.1 A							
AC rating (UL 508; NEMA ICS-5)	Utilization category (pilot duty)	B300							
DC rating (UL 508; NEMA ICS-5)	Utilization category (pilot duty)	R300							
Minimum switching power		0.6 W / 0.6 VA							
Mechanical lifetime		1 x 10 ⁷ switching cycles							
Electrical lifetime	at AC15	1 x 10 ⁵ switching cycles							
Response time		5 ms	5 ms	5 ms	5 ms	5 ms	6 ms	7 ms	
Release time		8 ms					15 ms	16 ms	
Dimensions and weight		RB 121 / RB 121A high level			RBR 122 / RBR 122A high level				
Weight	net weight	0.02 kg (0.044 lb)							
Dimension	product dimension	6 x 70 x 75 mm (0.236 x 2.76 x 2.95 in)			6 x 75 x 75 mm (0.236 x 2.95 x 2.95 in)				
	packaging dimension								

Interface relays R600 range

Technical data

Technical data

		RB... 121 / RB... 121A low level						
Input circuit								
Rated control supply voltage U _s		5 V DC	12 V DC	24 V AC/DC	48 V AC/DC	60 V AC/DC	115 V AC/DC	230 V AC/DC
Rated control supply voltage U _s tolerance	DC	-15 %, +20 %						-15 %, +10 %
	AC	-						-/+ 10 %
Rated frequency		-						50/60 Hz
Typical power consumption		0.2 W	0.2 W	0.24 W	0.33 W	0.54 W	0.46 W	0.8 W
Typical current		40 mA	16 mA	10 mA	7 mA	9 mA	4 mA	3.5 mA
Drop-out		1.2 V	2.2 V	4.5 V	8 V	8 V	17 V	27 V
Indication of operational states	green LED	┌ ───┐: control supply voltage applied						
Output circuit								
Kind of output	11-12/14	relay, 1 c/o (SPDT) contact						
Rated operational voltage U _e (IEC/EN 60947-1)		250 V AC						
Minimum switching voltage		5 V						
Maximum switching voltage		250 V AC						
Minimum switching current		1 mA						
Rated operational current (IEC/EN 60947-5-1)	AC12 (resistive) 230 V	6 A						
	AC15 (inductive) 230 V	1.5 A						
	AC15 (inductive) 120 V	3 A						
	DC12 (resistive) 24 V	6 A						
	DC13 (inductive) 24 V	1 A						
	DC13 (inductive) 120 V	0.2 A						
	DC13 (inductive) 230 V	0.1 A						
AC rating (UL 508; NEMA ICS-5)	Utilization category (pilot duty)	B300						
DC rating (UL 508; NEMA ICS-5)	Utilization category (pilot duty)	R300						
Minimum switching power		0.05 W / 0.05 VA						
Mechanical lifetime		1 x 10 ⁷ switching cycles						
Electrical lifetime	at AC15	1 x 10 ⁹ switching cycles						
Response time		5 ms	5 ms	5 ms	5 ms	5 ms	6 ms	7 ms
Release time		8 ms					15 ms	16 ms
Dimensions and weight		RB 121 / RB 121A low level			RBR 122 / RBR 122A low level			
Weight	net weight	0.02 kg (0.044 lb)						
Dimension	product dimension	6 x 70 x 75 mm (0.236 x 2.76 x 2.95 in)			6 x 75 x 75 mm (0.236 x 2.95 x 2.95 in)			
	packaging dimension							

5

Interface relays R600 range

Technical data

Technical data

		RB... 121AR / RB... 121AI low level			RB... 121AI low level
Input circuit					
Rated control supply voltage U _s		115 V AC/DC	230 V AC/DC	24 V AC/DC	24 V AC/DC
Rated control supply voltage U _s tolerance	DC	-20%, +15%	-10%, +15%	-20%, +15%	
	AC	-/+ 10 %			
Rated frequency		50/60 Hz			
Typical power consumption		2 W	2.8 W	0.24 W	0.24 W
Typical current		18 mA	12 mA	10 mA	10 mA
Drop-out		17 V	27 V	4.5 V	
Indication of operational states	green LED	┌───┐: control supply voltage applied			
Output circuit					
Kind of output	11-12/14	relay, 1 c/o (SPDT) contact			
Rated operational voltage U _a (IEC/EN 60947-1)		250 V AC			
Minimum switching voltage		12 V			5 V
Maximum switching voltage		250 V AC			
Minimum switching current		10 mA			1 mA
Rated operational current (IEC/EN 60947-5-1)	AC12 (resistive) 230 V	6 A			
	AC15 (inductive) 230 V	1.5 A			
	AC15 (inductive) 120 V	3 A			
	DC12 (resistive) 24 V	6 A			
	DC13 (inductive) 24 V	1 A			
	DC13 (inductive) 120 V	0.2 A			
	DC13 (inductive) 230 V	0.1 A			
AC rating (UL 508; NEMA ICS-5)	Utilization category (pilot duty)	B300			
DC rating (UL 508; NEMA ICS-5)	Utilization category (pilot duty)	R300			
Minimum switching power		0.6 W / 0.6 VA			0.05 W / 0.05 VA
Mechanical lifetime		1 x 10 ⁷ switching cycles			
Electrical lifetime	at AC15	1 x 10 ⁵ switching cycles			
Response time		6 ms	7 ms	5 ms	5 ms
Release time		15 ms	16 ms	8 ms	8 ms
Dimensions and weight		RB 121AR/RB 121AI low/high level		RB 121AR/RBR 121AI low/high level	
Weight	net weight	0.03 kg (0.066 lb)			
Dimension	product dimension	12 x 70 x 75 mm (0.472 x 2.76 x 2.95 in)			12 x 75 x 75 mm (0.472 x 2.95 x 2.95 in)
	packaging dimension				

5

Technical data

		RB... 122A low level				
Input circuit						
Rated control supply voltage U _s		24 V AC/DC	48 V AC/DC	60 V AC/DC	115 V AC/DC	230 V AC/DC
Rated control supply voltage U _s tolerance	DC	-15 %, +20 %				-15 %, +10 %
	AC	-/+ 10 %				
Rated frequency		50/60 Hz				
Typical power consumption		0.48 W	0.62 W	0.96 W	0.58 W	1.15 W
Typical current		20 mA	13 mA	16 mA	5 mA	5 mA
Drop-out		5.4 V	8.8 V	8.8 V V	20 V	10 V
Indication of operational states	green LED	┌───┐: control supply voltage applied				
Output circuit						
Kind of output	11-12/14	relay, 1st c/o (SPDT) contact				
	21-22/24	relay, 2nd c/o (SPDT) contact				
Rated operational voltage U _a (IEC/EN 60947-1)		250 V AC				
Minimum switching voltage		5 V				
Maximum switching voltage		250 V DC - 250 V AC				
Minimum switching current		1 mA				
Rated operational current (IEC/EN 60947-5-1)	AC12 (resistive) 230 V	8 A		5 A		
Minimum switching power		5 mW / 5 mVA				
Mechanical lifetime		2 x 10 ⁷ switching cycles				
Electrical lifetime	at AC15	1 x 10 ⁵ switching cycles				
Response time		6 ms	10 ms	10 ms	6 ms	6 ms
Release time		10 ms	14 ms	14 ms	15 ms	15 ms
Dimensions and weight		RB 122A low level			RBR 122A low level	
Weight	net weight	0.03 kg (0.066 lb)				
Dimension	product dimension	12 x 70 x 75 mm (0.472 x 2.76 x 2.95 in)			12 x 75 x 75 mm (0.472 x 2.95 x 2.95 in)	
	packaging dimension					

Interface relays R600 range

General technical data

Technical data

		RB	RBR
General data			
Material of housing		UL 94 V0	
Degree of protection	housing / terminals	IP20 NEMA1	
Electrical connection		Screw terminal	Spring-type terminal
Wire size	fine-stranded	0.22-2.5 mm ² (24-14 AWG)	
	rigid	0.2-4 mm ² (24-12 AWG)	0.2-2.5 mm ² (24-14 AWG)
Stripping length		9 mm / 0.354 in	
Tightening torque		0.4-0.6 Nm (3.5-5.3 lb.in)	
Environmental data			
Ambient temperature ranges	storage	-40...+80 °C	
	operation	-20...+70 °C	
Isolation data			
Rated insulation voltage U _i (IEC/EN 60950-1, EN 50178)		4000 V RMS	
Rated impulse withstand voltage U _{imp} (EN 50178)	input / output	4000 V RMS (RB122A: 3800 V RMS, RB111AR: 3500 V RMS)	
	shock coil / output	4000 V RMS	
	output / output	1000 V RMS	

Interface relays R600 range

Dimensional drawings, Load limit curves

All interface relays of R600 range

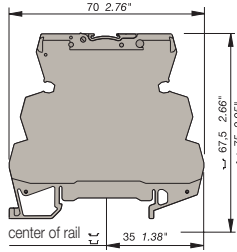

Screw clamp module

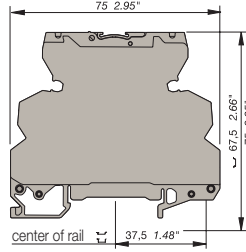

Spring clamp module

Load limit curves

RB 111 A, RB 111 AI, RB 111 AR, RB 101 AR,
 RB 121 AR, RB 121 AI, RB 121 AI (gold plated), RB 121 AI
 RB 121 (gold plated), RB 121 A (gold plated), RB 121, RB 121 A

Load limit curve RB ... 122A (gold plated)

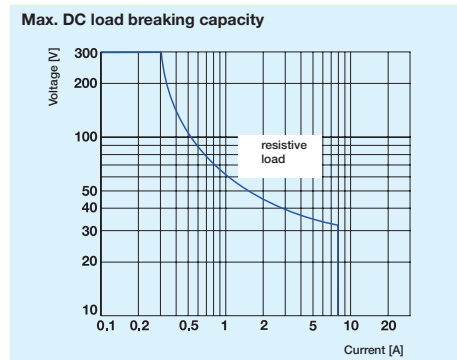
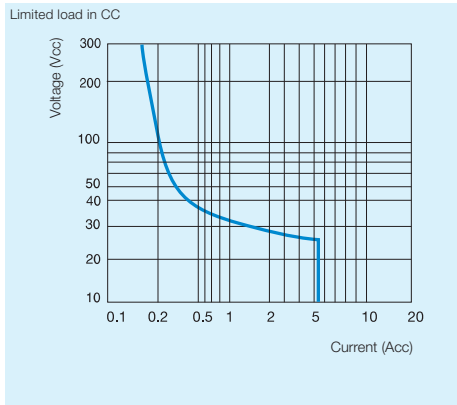

	DC12	AC12	DC13	AC15
24 V	6 A	6 A	1	3 A
110/120 V	0,3 A	6 A	0,2 A	3 A
220/230 V	0,2 A	6 A	0,1 A	3 A

Optocouplers R600 range

Product group picture

5



Optocouplers R600 range

Table of contents

Optocouplers R600 range	
Product group picture	5/63
Table of contents	5/64
Selection	5/65
Ordering details	5/67
Connection diagrams	5/68
Technical data	5/69

Optocouplers R600 range Selection

	Type	Order number
	OBIC 0100 5-12VDC	1SNA 645 047 R0000
	OBRIC 0100 5-12VDC	1SNA 645 547 R0200
	OBIC 0100 24VDC	1SNA 645 021 R2600
	OBRIC 0100 24VDC	1SNA 645 521 R2000
	OBIC 0100 48-60VAC/DC	1SNA 645 049 R1200
	OBRIC 0100 48-60VAC/DC	1SNA 645 549 R1400
	OBIC 0100 115-230VAC/DC	1SNA 645 022 R2700
	OBRIC 0100 115-230VAC/DC	1SNA 645 522 R2100
	OBOC 1000-5-12VDC	1SNA 645 050 R1700
	OBROC 1000-5-12VDC	1SNA 645 550 R1100
	OBOC 1000-24VDC	1SNA 645 051 R0400
	OBOC 1500-24VAC/DC	1SNA 645 025 R2200
	OBOC 5000-24VDC	1SNA 645 024 R2100
	OBROC 1000-24VDC	1SNA 645 551 R0600
	OBROC 1500-24VAC/DC	1SNA 645 525 R2400
	OBROC 5000-24VDC	1SNA 645 524 R2300
	OBOC 1000-48-60VAC/DC	1SNA 645 053 R0600
	OBROC 1000-48-60VAC/DC	1SNA 645 553 R0000
	OBOC 1000-115VAC/DC	1SNA 645 054 R0700
	OBOC 5000-115VAC/DC	1SNA 645 058 R1300
	OBROC 1000-115VAC/DC	1SNA 645 554 R0100
	OBROC 5000-115VAC/DC	1SNA 645 558 R1500
	OBOC 1000-230VAC/DC	1SNA 645 026 R2300
	OBOC 5000-230VAC/DC	1SNA 645 059 R1400
	OBROC 1000-230VAC/DC	1SNA 645 526 R2500
	OBROC 5000-230VAC/DC	1SNA 645 559 R1600
	OBOA 1000-24VDC	1SNA 645 027 R2400
	OBOA 2000-24VDC	1SNA 645 029 R0600
	OBROA 1000-24VDC	1SNA 645 527 R2600
	OBROA 2000-24VDC	1SNA 645 529 R0000

Input voltage																												
5 - 12 V DC	■	■																										
24 V DC			■	■																								
48 - 60 V DC					■	■																						
115 - 230 V DC							■	■																				
115 V DC																												
230 V DC																												
24 V AC																												
48 - 60 V AC																												
115-230 V AC																												
115 V AC																												
230 V AC																												

Output rating																												
100 mA	■	■	■	■	■	■	■	■																				
2 A																												
5 A																												
1 A																												

Output voltage																												
58 V DC	■	■	■	■	■	■	■	■	■	■	■	■	■	■	■	■	■	■	■	■	■	■	■	■	■	■	■	■
400 V AC																												

Terminal type																												
Screw	■		■		■		■		■		■		■		■		■		■		■		■		■		■	
Spring		■		■		■		■		■		■		■		■		■		■		■		■		■		■

Optocouplers R600 range

Selection

OBOA 1000-48-60VAC/DC	1SNA 645 061 R0600
OBROA 1000-48-60VAC/DC	1SNA 645 561 R0000
OBOA 1000-115VAC/DC	1SNA 645 062 R0700
OBROA 1000-115VAC/DC	1SNA 645 562 R0100
OBOA 1000-230VAC/DC	1SNA 645 028 R0500
OBROA 1000-230VAC/DC	1SNA 645 528 R0700

Optocouplers R600 range

Ordering details



2CDC291 001 F0013

5

R600 Optocoupler	Type	Order code	Price	Pkg qty	Weight (1 pce) kg (lb)
Optocoupler module 100 mA/DC	OBIC 0100-5-12VDC	1SNA645047R0000		10	0.02 (0.44)
	OBIC 0100-24VDC	1SNA645021R2600			
	OBIC 0100-48-60VAC/DC	1SNA645049R1200			
Optocoupler module 100 mA/DC	OBIC 0100-115-230VAC/DC	1SNA645022R2700		10	0.02 (0.44)
	OBRIC 0100-5-12VDC	1SNA645547R0200			
	OBRIC 0100-24VDC	1SNA645521R2000			
Optocoupler module 100 mA/DC	OBRIC 0100-48-60VAC/DC	1SNA645549R1400		10	0.02 (0.44)
	OBRIC 0100-115-230VAC/DC	1SNA645522R2100			
	OBOC 1000-5-12VDC	1SNA645050R1700			
Optocoupler module 2 A/DC	OBOC 1000-24VDC	1SNA645051R0400		10	0.02 (0.44)
	OBOC 1500-24VAC/DC	1SNA645025R2200			
	OBOC 1000-48-60VAC/DC	1SNA645053R0600			
Optocoupler module 2 A/DC	OBOC 1000-115VAC/DC	1SNA645054R0700		10	0.02 (0.44)
	OBOC 1000-230VAC/DC	1SNA645026R2300			
	OBROC 1000-5-12VDC	1SNA645550R1100			
Optocoupler module 2 A/DC	OBROC 1000-24VDC	1SNA645551R0600		10	0.02 (0.44)
	OBROC 1500-24VAC/DC	1SNA645525R2400			
	OBROC 1000-48-60VAC/DC	1SNA645553R0000			
Optocoupler module 2 A/DC	OBROC 1000-115VAC/DC	1SNA645554R0100		10	0.02 (0.44)
	OBROC 1000-230VAC/DC	1SNA645526R2500			
	OBOC 5000-24VDC	1SNA645024R2100			
Optocoupler module 5 A/DC	OBOC 5000-115VAC/DC	1SNA645058R1300		10	0.02 (0.44)
	OBOC 5000-230VAC/DC	1SNA645059R1400			
Optocoupler module 5 A/DC	OBROC 5000-24VDC	1SNA645524R2300		10	0.02 (0.44)
	OBROC 5000-115VAC/DC	1SNA645558R1500			
Optocoupler module 5 A/DC	OBROC 5000-230VAC/DC	1SNA645559R1600		10	0.02 (0.44)
	OBOA 1000-24VDC	1SNA645027R2400			
Optocoupler module 1 A/AC 6 mm spacing	OBOA 1000-48-60VAC/DC	1SNA645061R0600		10	0.03 (0.066)
	OBOA 1000-115VAC/DC	1SNA645062R0700			
	OBOA 1000-230VAC/DC	1SNA645028R0500			
Optocoupler module 2 A/AC 12 mm spacing	OBOA 2000-24VDC	1SNA645029R0600		5	0.03 (0.066)
Optocoupler module 1 A/AC 6 mm spacing	OBROA 1000-24VDC	1SNA645527R2600		10	0.03 (0.066)
	OBROA 1000-48-60VAC/DC	1SNA645561R0000			
	OBROA 1000-115VAC/DC	1SNA645562R0100			
	OBROA 1000-230VAC/DC	1SNA645528R0700			
Optocoupler module 2 A/AC 12 mm spacing	OBROA 2000-24VDC	1SNA645529R0000		5	0.03 (0.066)

Accessories	Type	Order code	Price	Pkg qty	Weight (1 pce) kg (lb)
End section	BADH V0	1SNA116900R2700		50	
	BADL V0	1SNA399903R0200		50	
	BAM2 V0	1SNA399967R0100		50	
Separator end section	SC 612	1SNA290474R0200		10	
Divisible shunt 10 poles	BJ 612-10	1SNA290488R0100		10	
Divisible shunt 20 poles	BJ 612-20	1SNA206754R0000		10	
Screw clamp distribution block sp. 12 mm	D4/12-3-3	1SNA645031R2000		5	
Spring clamp distribution block sp. 12 mm	D4/12-3R-3R	1SNA645531R2200		5	
Test plug DIA. 2 mm	FC2	1SNA645531R2200		10	
Marking method	RC65 / RC610	see marking			

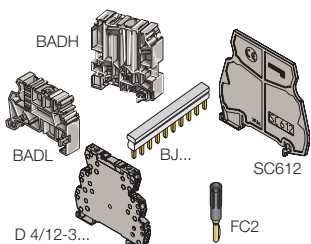

Optocouplers R600 range

Connection diagrams

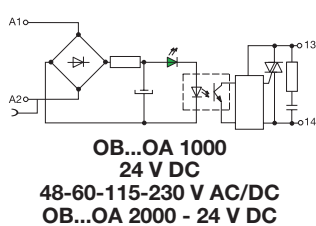
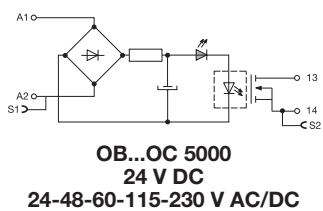
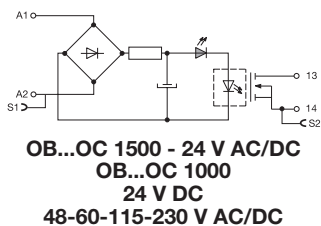
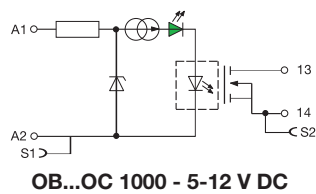
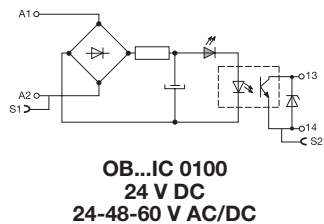
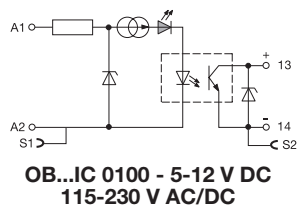





Optocouplers R600 range

Technical data

Technical data

Optocoupler : 5 to 58 V DC output / 100 mA - 6 mm 0.236" spacing

5

		OB...IC 0100					
Relay characteristics coil							
Input voltage: +20%, -15% on DC ; 10%, -10% on AC	5 V DC - 12 V DC	24 V DC		48 V AC/DC	60 V AC/DC	115 V AC/DC	230 V AC/DC
Frequency				50 / 60 Hz			
Input current AC/DC	5 mA	9 mA	4 mA	4 mA	5 mA	7 mA / 16 mA	11.5 mA / 25 mA
Pull-in voltage at Is=100%	4 V		15 V	25 V		60 V AC / 70 V DC	
Switching time C / O	10 µs / 500 µs						
Operating frequency	1000 Hz			5 ms / 20 ms		5 ms / 15 ms	
Permissible leakage current				20 Hz			
Output	0.9 mA	1 mA		0.9 mA	1.6 mA		
Output voltage	4.5 to 58 V DC						
Output current min.	1 mA						
Output current max.	100 mA						
Output leakage current at U _{max}	< 50 µA						
Residual voltage at I max and U rated	typical	1 V					
	max	1.3 V					
Frequency on inductive load							
Isolation Input / Output	input / Output	2500 V RMS					
Temperature	storage	-40...+80 °C					
	operating	-20...+70 °C ¹⁾					
Other characteristics		Screw clamp			Spring clamp		
Body material	grey	UL 94 V0					
Wire size	Solid wire	0.2 - 4 mm ² (24-12 AWG)			0.2-2.5 mm ² (24-12 AWG)		
	Stranded wire	0.22 - 2.5 mm ² (24-12 AWG)					
Rated wire size	2.5 mm ² (12 AWG)						
Wire stripping length	9 mm (0.354 in)						
Recommended screwdriver	3.5 mm (0.137 in)						
Protection	IP20 NEMA1						
Recommended torque	0.4-0.6 Nm (3.5-5.3 lb.in)						
Approvals	c  US (pending for 12 V DC) ,  (pending) ,  , LRS , 						
Reference standards	CEI 947-7-1 / CEI 947-1 / CEI 1131-2 (in relevant parts) / CEI 60664-1 / CEM : IEC 1000-4-2, 3, 4, 5, 6.						

¹⁾ Over 55°C, blocks have to be mounted on horizontal rail with 10 mm spacing between each block. For vertical rail mounting use temperature is 15°C less decreased.

Dimensional drawings

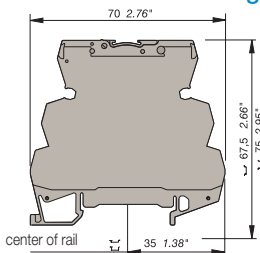

Screw clamp module

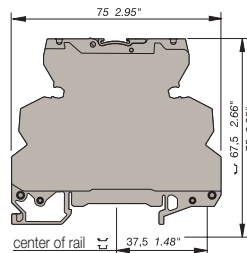





Spring clamp module

Optocouplers R600 range

Technical data

Technical data

Optocoupler : 5 to 58 V DC output / 2 A - 6 mm 0.236" spacing

	OB...OC 0100		OB..OC 1500	OB...OC 1000				
Relay characteristics coil								
Input voltage: +20%, -15% on DC ; 10%, -10% on AC	5 V DC - 12 V DC		24 V DC	24 V AC/DC	48 V AC/DC	60 V AC/DC	115 V AC/DC	230 V AC/DC
Frequency			50 / 60 Hz					
Input current	5 mA	9 mA	4 mA	6.3 mA	4 mA	5.1 mA	4.2 mA	4 mA
Pull-in voltage at Is=100%	4 V		15 V	15 V	27 V		50 V	80 V
Switching time C / O	15 µs / 250 µs		30 µs / 400 µs	1 ms / 7 ms	5 ms / 20 ms		500 µs / 10 ms	1 ms / 15 ms
Operating frequency	2000 Hz		1000 Hz	60 Hz	20 Hz			
Permissible leakage current	1 mA		0.8 mA	0.9 mA	1 mA		0.3 mA	
Output								
Output voltage	4.5 to 58 V DC							
Output current min.	1 mA							
Output current max.	2 A							
Output leakage current at U _{max}	< 50 µA							
Residual voltage at I max and U rated	typical		0.1 V					
	max		0.5 V					
Frequency on inductive load								
Isolation Input / Output	input / Output	2500 V RMS						
Temperature	storage		-40...+80 °C					
	operating		-20...+70 °C ¹⁾					
Other characteristics			Screw clamp			Spring clamp		
Body material	grey	UL 94 V0						
Wire size	Solid wire	0.2 - 4 mm ² (24-12 AWG)			0.2-2.5 mm ² (24-12 AWG)			
	Stranded wire	0.22 - 2.5 mm ² (24-12 AWG)						
Rated wire size	2.5 mm ² (12 AWG)							
Wire stripping length	9 mm (0.354 in)							
Recommended screwdriver	3.5 mm (0.137 in)							
Protection	IP20 NEMA1							
Recommended torque	0.4-0.6 Nm (3.5-5.3 lb.in)							
Approvals	c  us (pending for 12 V DC) ,  (pending) ,  , LRS , 							
Reference standards	CEI 947-7-1 / CEI 947-1 / CEI 1131-2 (in relevant parts) / CEI 60664-1 / CEM : IEC 1000-4-2, 3, 4, 5, 6.							

¹⁾ Over 55°C, blocks have to be mounted on horizontal rail with 10 mm spacing between each block. For vertical rail mounting use temperature is 15°C less decreased.

Dimensional drawings

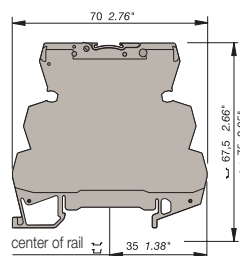

Screw clamp module

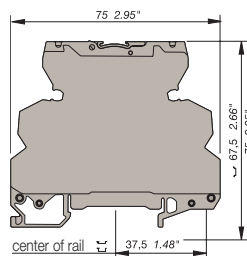



Spring clamp module

Optocouplers R600 range

Technical data

Technical data

Optocoupler : 5 to 58 V DC output / 5 A - 6 mm 0.236" spacing

		OB... OC 5000		
Input				
Input voltage	24 V DC	115 V AC/DC	230 V AC/DC	
Frequency		50 / 60 Hz	50 / 60 Hz	
Input current	5.4 mA	4.2 mA	4 mA	
Pull-in voltage at Is=100%	12 V	50 V	80 V	
Switching time C / O	30 µs / 400 µs	500 µs / 10 ms	1ms / 15 ms	
Operating frequency	1000 Hz	50 Hz	35 Hz	
Permissible leakage current	0.8 mA	0.3 mA	0.3 mA	
Output				
Output voltage	4.5- 58 V DC			
Output current min.	25 mA			
Output current max.	5 A			
Output leakage current at U _{max}	< 0.50 mA			
Residual voltage at I max and U rated	typical	1 V		
	max	1.6 V		
Frequency on inductive load	See Note 1			
Isolation Input / Output	input / Output	2500 V RMS		
Temperature				
Ambient temperature	storage	-40...+80 °C		
	operating	See derating curve		
Other characteristics				
Body material	grey	UL 94 V0		
Wire size	Solid wire	0.2 - 4 mm ² (24-12 AWG)		
	Stranded wire	0.22 - 2.5 mm ² (24-12 AWG)		
Rated wire size	2.5 mm ² (12 AWG)			
Wire stripping length	10 mm (0.394 in)			
Recommended screwdriver	3.5 mm (0.137 in)			
Protection	IP20 NEMA1			
Recommended torque	0.4-0.6 Nm (3.5-5.3 lb.in)			
Approvals	c  US (pending), 			
Reference standards	CEI 947-7-1 / CEI 947-1 / CEI 1131-2 (in relevant parts) / CEI 60664-1 / CEM : IEC 1000-4-2, 3, 4, 5, 6.			

Dimensional drawings

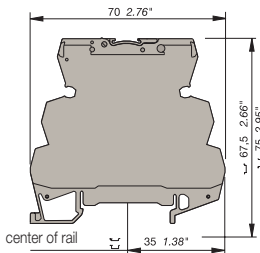

Screw clamp module

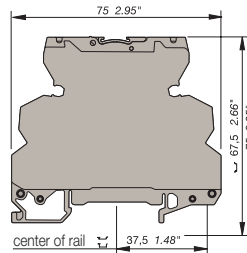





Spring clamp module

Optocouplers R600 range

Technical data

Technical data

Optocoupler : 24 to 400 V AC output / 2 A max. - 6 mm or 12 mm spacing

	OB...OA 1000					OB...OA 2000	
Relay characteristics coil							
Input voltage: +20%, -15% on DC ; 10%, -10% on AC	24 V DC	48 V AC/DC	60 V AC/DC	115 V AC/DC	230 V AC/DC	24 V DC	
Frequency		50/60 Hz					
Input current	3.6 mA	4.3 mA	5.5 mA	4.15 mA	4.6 mA	3.6 mA	
Pull-in voltage at Is=100%	14 V	15 V	18 V	60 V	135 V	14 V	
Switching time C / O	150 µs / 1 ms	3 ms / 30 ms		2.2 ms / 18 ms	2.5 ms / 25 ms	150 µs / 1 ms	
Operating frequency	500 Hz	20 Hz		25 Hz	20 Hz	500 Hz	
Permissible leakage current	1 mA						
Output							
Output voltage	24-400 V AC						
Frequency	50/60 Hz						
Output current min.	25 mA						
Output current max.	1 A						2 A
Output leakage current at U _{max}	< 0.50 mA						
Residual voltage at I _{max} and U rated	typical	1 V					
	max	1.6 V					
Frequency on inductive load							
Isolation Input / Output	input / Output	2500 V RMS					
Temperature	storage	-40...+80 °C					
	operating	-20...+70 °C ¹⁾					
Other characteristics		Screw clamp			Spring clamp		
Body material	grey	UL 94 V0					
Wire size	Solid wire	0.2 - 4 mm ² (24-12 AWG)			0.2-2.5 mm ² (24-12 AWG)		
	Stranded wire	0.22 - 2.5 mm ² (24-12 AWG)					
Rated wire size		2.5 mm ² (12 AWG)					
Wire stripping length		9 mm (0.354 in)					
Recommended screwdriver		3.5 mm (0.137 in)					
Protection		IP20 NEMA1					
Recommended torque		0.4-0.6 Nm (3.5-5.3 lb.in)					
Approvals		 us (pending for 12 V DC) ,  (pending),  , LRS , 					
Reference standards		CEI 947-7-1 / CEI 947-1 / CEI 1131-2 (in relevant parts) / CEI 60664-1 / CEM : IEC 1000-4-2, 3, 4, 5, 6.					

¹⁾ Over 55°C, blocks have to be mounted on horizontal rail with 10 mm spacing between each block. For vertical rail mounting use temperature is 15°C less decreased.

Dimensional drawings

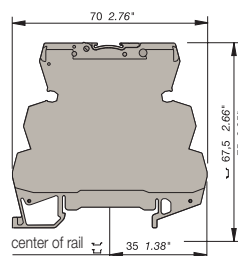

Screw clamp module

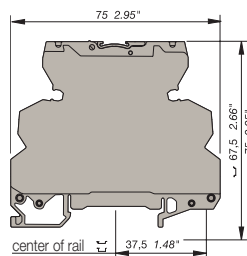

Spring clamp module

Terminal blocks component holder

Base for pluggable plug
R500 Series

DIN 3

End stop		th. 9 mm	BADL	V0	1SNA 399 903 R0200
End stop		th. 9,1 mm	BAM	V2	1SNA 103 002 R2600
End stop		th. 9,1 mm	BAM V0	V0	1SNA 199 306 R0300
Rail		35 x 7,5 x 1	PR3.Z2		1SNA 174 300 R1700
Rail		35 x 15 x 2,3	PR4		1SNA 168 500 R1200
Rail		35 x 15 x 1,5	PR5		1SNA 168 700 R2200

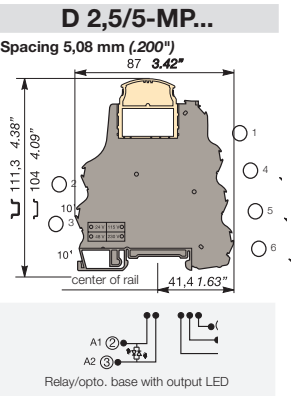
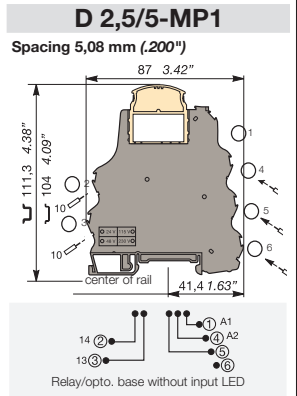
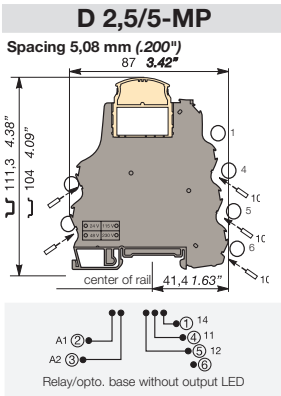

Observations	CE		CE		CE	
Terminal blocks are delivered without plugs.	Type	Part numbers	Type	Part numbers	Type	Part numbers
Max. working temperature version without LED : 100°C version with LED : 85°C Contact resistance : < 5 mΩ	Grey V0	Order plugs separately	Grey V0	Order plugs separately	Grey V0	Order plugs separately
	D 2,5/5-MP	1SNA607224R0100	D 2,5/5-MP1	1SNA607223R0000	D 2,5/5-MP-24VDC	1SNA607222R0700
					D 2,5/5-MP-24VAC/DC	1SNA607260R2100
					D 2,5/5-MP-48VAC/DC	1SNA607261R1600
					D 2,5/5-MP-110VAC	1SNA607266R1300
					D 2,5/5-MP-230VAC	1SNA607267R1400

Characteristics		IEC		UL/CSA pending		IEC		UL/CSA pending		IEC		UL/CSA pending	
Wire size	Compression clamp	Solid wire	0,2-4 mm²	24-12 AWG	0,2-4 mm²	24-12 AWG	0,2-4 mm²	24-12 AWG	0,2-4 mm²	24-12 AWG	0,2-4 mm²	24-12 AWG	
	Stranded wire		0,22-2,5 mm²	24-12 AWG	0,22-2,5 mm²	24-12 AWG	0,22-2,5 mm²	24-12 AWG	0,22-2,5 mm²	24-12 AWG	0,22-2,5 mm²	24-12 AWG	
Voltage	Rated		320 V	300 V	320 V	300 V	320 V	300 V	320 V	300 V	320 V	300 V	
	Pulse		4 kV		4 kV		4 kV		4 kV		4 kV		
	Pollution degree		3		3		3		3		3		
Current	Rated		6 A	6 A	6 A	6 A	6 A	6 A	6 A	6 A	6 A	6 A	
Wire size	Rated / Gauge		2,5 mm²	12 AWG	2,5 mm²	12 AWG	2,5 mm²	12 AWG	2,5 mm²	12 AWG	2,5 mm²	12 AWG	
Wire stripping length			10 mm / .394"		10 mm / .394"		10 mm / .394"		10 mm / .394"		10 mm / .394"		
Recommended screwdriver			3,5 mm / .137"		3,5 mm / .137"		3,5 mm / .137"		3,5 mm / .137"		3,5 mm / .137"		
Recommended torque			0,4-0,6 Nm / 3,5-5,3 lb.in		0,4-0,6 Nm / 3,5-5,3 lb.in		0,4-0,6 Nm / 3,5-5,3 lb.in		0,4-0,6 Nm / 3,5-5,3 lb.in		0,4-0,6 Nm / 3,5-5,3 lb.in		
Protection			IP 20 / NEMA1		IP 20 / NEMA1		IP 20 / NEMA1		IP 20 / NEMA1		IP 20 / NEMA1		

Accessories		Type		Part numbers		Type		Part numbers		Type		Part numbers	
	1 Test device	DCB	(1) blue	1SNA105028R2100	DCB	(1) blue	1SNA105028R2100	DCB	(1) blue	1SNA105028R2100	DCB	(1) blue	1SNA105028R2100
	2 Test plug	FC2	DIA. 2	1SNA007865R2600	FC2	DIA. 2	1SNA105028R2100	FC2	DIA. 2	1SNA007865R2600	FC2	DIA. 2	1SNA007865R2600
	3 Relay plug 1 SPDT 10 mA/6 A 1 SPDT 1 mA/6 A	BNMS R24V-1	beige	1SNA031820R1400	BNMS R24V-1	beige	1SNA031820R1400	BNMS R24V-1	beige	1SNA031820R1400	BNMS R24V-1	beige	1SNA031820R1400
	4 Input optocoupler plug 5 V DC 24 V DC 24 V DC 48 V DC 125 V DC 24 V AC 48 V AC 115 V AC 230 V AC	BNMS N24V-3	red	1SNA031807R1400	BNMS T5V-1	white	1SNA031831R0300	BNMS N24V-3	red	1SNA031807R1400	BNMS T24V-1	white	1SNA031848R2400
		BNMS P24V-3	red	1SNA031810R1200	BNMS T24V-2	white	1SNA031800R2100	BNMS P24V-3	red	1SNA031810R1200	BNMS T48V-1	white	1SNA031801R1600
		BNMS N24V-1	red	1SNA031813R0100	BNMS T125V-1	white	1SNA031845R1100	BNMS N24V-1	red	1SNA031813R0100	BNMS T24V-1	yellow	1SNA031802R1700
		BNMS P24V-1	red	1SNA031815R0300	BNMS T48V-1	yellow	1SNA031803R1000	BNMS P24V-1	red	1SNA031815R0300	BNMS T115V-1	yellow	1SNA031804R1100
		BNMS N24V-2	red	1SNA031817R0500	BNMS T230V-1	yellow	1SNA031805R1200	BNMS N24V-2	red	1SNA031817R0500	BNMS T24V-2	beige	1SNA031804R1100
		BNMS P24V-2	red	1SNA031819R1700				BNMS P24V-2	red	1SNA031819R1700	BNMS A24V-4	black	1SNA031839R1300
		BNMS A24V-4	black	1SNA031839R1300				BNMS A24V-4	black	1SNA031839R1300			
	5 Output optocoupler plug 5 V DC/100 mA 5 V DC/100 mA 48 V DC/100 mA 48 V DC/100 mA 5 V DC/2 A 5 V DC/2 A 5 V DC/1 A 5 V DC/1 A	BNMS N5V-3	red	1SNA031806R1300				BNMS N5V-3	red	1SNA031806R1300			
		BNMS P5V-3	red	1SNA031809R2600				BNMS P5V-3	red	1SNA031809R2600			
		BNMS N48V-3	red	1SNA031808R2500				BNMS N48V-3	red	1SNA031808R2500			
		BNMS P48V-3	red	1SNA031811R0700				BNMS P48V-3	red	1SNA031811R0700			
		BNMS N5V-1	red	1SNA031812R0000				BNMS N5V-1	red	1SNA031812R0000			
		BNMS P5V-1	red	1SNA031814R0200				BNMS P5V-1	red	1SNA031814R0200			
		BNMS N5V-2	red	1SNA031816R0400				BNMS N5V-2	red	1SNA031816R0400			
		BNMS P5V-2	red	1SNA031818R1600				BNMS P5V-2	red	1SNA031818R1600			
	7 Fuse plug 125 V/125 mA 125 V/500 mA 125 V/2 A 125 V/5 A 250 V/125 mA 250 V/2 A 250 V/5 A 125 V/125 mA 250 V/125 mA 125 V/2 A	BNMS F125mA-1	grey	1SNA031821R0100	BNMS F125mA-1	grey	1SNA031821R0100	BNMS F125mA-1	grey	1SNA031821R0100	BNMS F125mA-1	grey	1SNA031821R0100
		BNMS F500mA-1	grey	1SNA031838R1200	BNMS F500mA-1	grey	1SNA031838R1200	BNMS F500mA-1	grey	1SNA031838R1200	BNMS F500mA-1	grey	1SNA031838R1200
		BNMS F2A-1	grey	1SNA031822R0200	BNMS F2A-1	grey	1SNA031822R0200	BNMS F2A-1	grey	1SNA031822R0200	BNMS F2A-1	grey	1SNA031822R0200
		BNMS F5A-1	grey	1SNA031823R0300	BNMS F5A-1	grey	1SNA031823R0300	BNMS F5A-1	grey	1SNA031823R0300	BNMS F5A-1	grey	1SNA031823R0300
		BNMS F125mA-2	grey	1SNA031824R0400	BNMS F125mA-2	grey	1SNA031824R0400	BNMS F125mA-2	grey	1SNA031824R0400	BNMS F125mA-2	grey	1SNA031824R0400
		BNMS F2A-2	grey	1SNA031825R0500	BNMS F2A-2	grey	1SNA031825R0500	BNMS F2A-2	grey	1SNA031825R0500	BNMS F2A-2	grey	1SNA031825R0500
		BNMS F5A-2	grey	1SNA031826R0600	BNMS F5A-2	grey	1SNA031826R0600	BNMS F5A-2	grey	1SNA031826R0600	BNMS F5A-2	grey	1SNA031826R0600
		BNMS F125mA-3	grey	1SNA031827R0700	BNMS F125mA-3	grey	1SNA031827R0700	BNMS F125mA-3	grey	1SNA031827R0700	BNMS F125mA-3	grey	1SNA031827R0700
		BNMS F125mA-4	grey	1SNA031828R1000	BNMS F125mA-4	grey	1SNA031828R1000	BNMS F125mA-4	grey	1SNA031828R1000	BNMS F125mA-4	grey	1SNA031828R1000
		BNMS F2A-7	grey	1SNA031849R2500	BNMS F2A-7	grey	1SNA031849R2500	BNMS F2A-7	grey	1SNA031849R2500	BNMS F2A-7	grey	1SNA031849R2500
	8 Strap plug	BNMS ST1	grey	1SNA031829R1100	BNMS ST1	grey	1SNA031829R1100	BNMS ST1	grey	1SNA031829R1100	BNMS ST1	grey	1SNA031829R1100
		BNMS ST2	grey	1SNA031830R1600	BNMS ST2	grey	1SNA031830R1600	BNMS ST2	grey	1SNA031830R1600	BNMS ST2	grey	1SNA031830R1600
	9 Converter plug 0-20 mA/0-10 V 4-20 mA/2-10 V 0-20 mA/0-5 V 4-20 mA/1-5 V	BNMS CAI/U-500	grey	1SNA031832R0400	BNMS CAI/U-500	grey	1SNA031832R0400	BNMS CAI/U-500	grey	1SNA031832R0400	BNMS CAI/U-500	grey	1SNA031832R0400
		BNMS CAI/U-250	grey	1SNA031833R0500	BNMS CAI/U-250	grey	1SNA031833R0500	BNMS CAI/U-250	grey	1SNA031833R0500	BNMS CAI/U-250	grey	1SNA031833R0500
	10 Comb type jumper bar 10 poles	PCMS V0 (2)		1SNA205523R2200	PCMS V0 (2)		1SNA205523R2200	PCMS V0 (2)		1SNA205523R2200	PCMS V0 (2)		1SNA205523R2200
	R See section on marking	RC 55			RC 55			RC 55			RC 55		

(1) Solely on the top stage. (2) Comb type jumper bar from 2 to 22 poles, see accessories.

Input optocoupler plugs

2CDC 292.013 F0013

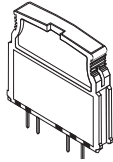

DC plugs

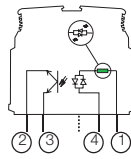

Derating curve

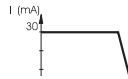

AC plugs

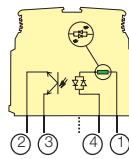

Derating curve

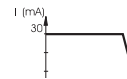

Switching time R_L curve 1 for 24 V DC plugs only

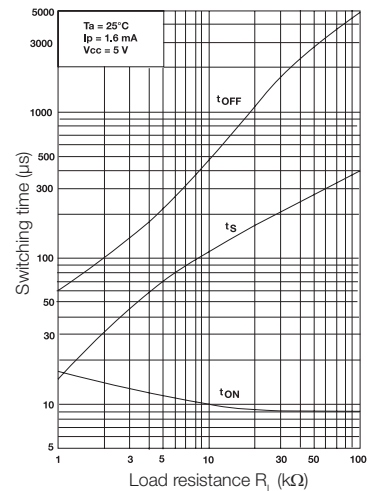

Part number	5 V DC		24 V DC		48 V DC		125 V DC	
	Type	P/N	Type	P/N	Type	P/N	Type	P/N
	BNMS T5V-1	1SNA031831R0300	BNMS T24V-1	1SNA031800R2100	BNMS T48V-1	1SNA031801R1600	BNMS T125V-1	1SNA031845R1100
			BNMS T24V-2	1SNA031848R2400				
Characteristics								
INPUT			BNMS T24V-1	BNMS T24V-2				
Voltage	4,5 V to 5,5 V DC		19,2 V to 27,6 V DC		38,4 V to 55,2 V DC		93,5 V to 140 V DC	
Max. current	6 mA		5 mA		4,1 mA		3 mA	
Typical triggering threshold at $I_S = 100\%$	3,5 V		12 V DC		21 V DC		50 V DC	
Switching time	C/O	20 µs / 1,3 ms	20 µs / 1,3 ms	10 µs / see curve 1	20 µs / 1,3 ms		20 µs / 1,3 ms	
Leakage current			1 mA		0,8 mA			
OUTPUT								
Max. voltage. / Max. current	58 V / 30 mA		58 V / 30 mA	58 V / 5 mA	58 V / 30 mA		58 V / 30 mA	
Residual voltage max. I and rated U standard	2,3 V DC		2,3 V DC	0,3 V DC	2,3 V DC		2,3 V DC	
max.	2,7 V DC		2,7 V DC	0,5 V DC	2,7 V DC		2,7 V DC	
Compatibility			TTL					
Input / Output isolation	2,5 kV		2,5 kV		2,5 kV		2,5 kV	
TEMPERATURE								
Storage	- 30°C to + 80°C		- 30°C to + 80°C		- 30°C to + 80°C		- 30°C to + 80°C	
Operating	- 20°C to + 55°C		- 20°C to + 55°C		- 20°C to + 55°C		- 20°C to + 55°C	
Part number	24 V AC		48 V AC		115 V AC		230 V AC	
	Type	P/N	Type	P/N	Type	P/N	Type	P/N
	BNMS T24V-1	1SNA031802R1700	BNMS T48V-1	1SNA031803R1000	BNMS T115V-1	1SNA031804R1100	BNMS T230V-1	1SNA031805R1200
Charateristics								
INPUT								
Voltage	20,4 V to 26,4 V AC		40,8 V to 52,8 V AC		98 V to 126,5 V AC		195,5 V to 253 V AC	
Max. current	8,5 mA		4,5 mA		8 mA		7 mA	
Typical triggering threshold at $I_S = 100\%$	13 V AC		22 V AC		50 V AC		95 V AC	
Switching time	C/O	6 ms / 10 ms	6 ms / 10 ms		6 ms / 10 ms		6 ms / 10 ms	
Leakage current	1 mA		1 mA		2 mA		2 mA	
OUTPUT								
Max. voltage / Max. current	58 V / 30 mA		58 V / 30 mA		58 V / 30 mA		58 V / 30 mA	
Residual voltage max. I and rated U standard	2,3 V DC		2,3 V		2,3 V		2,3 V	
max.	2,7 V DC		2,7 V		2,7 V		2,7 V	
Input / Output isolation	2,5 kV		2,5 kV		2,5 kV		2,5 kV	
TEMPERATURE								
Storage	- 30°C to + 80°C		- 30°C to + 80°C		- 30°C to + 80°C		- 30°C to + 80°C	
Operating	- 20°C to + 55°C		- 20°C to + 55°C		- 20°C to + 55°C		- 20°C to + 55°C	

Transistor output optocoupler plugs

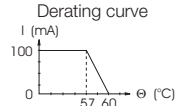
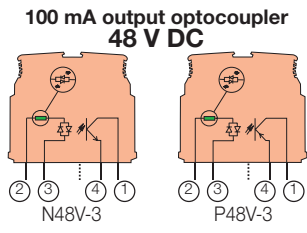
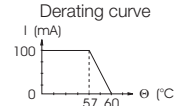
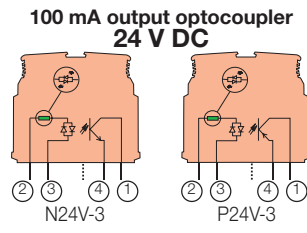
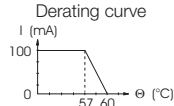
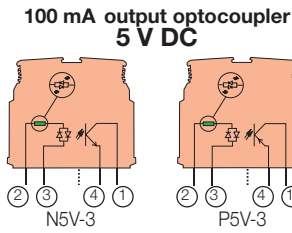
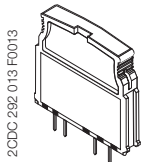

Part numbers	Type	P/N	Type	P/N	Type	P/N
	BNMS N5V-3	1SNA031806R1300	BNMS N24V-3	1SNA031807R1400	BNMS N48V-3	1SNA031808R2500
	BNMS P5V-3	1SNA031809R2600	BNMS P24V-3	1SNA031810R1200	BNMS P48V-3	1SNA031811R0700
Characteristics						
INPUT						
Voltage	4,5 V to 5,5 V DC		20,4 V to 28,8 V DC		40,8 V to 57,6 V DC	
Max. current	8,5 mA		4,8 mA		3,9 mA	
Typical triggering threshold at $I_s = 100\%$	2,9 V DC		16 V DC		26 V DC	
Switching time	C/O	20 μ s / 1,3 ms	20 μ s / 1,3 ms		20 μ s / 1,3 ms	
Leakage current	1 mA		1 mA		1 mA	
OUTPUT						
Max. voltage / Max. current	58 V / 100 mA		58 V / 100 mA		58 V / 100 mA	
Residual voltage max. I and rated U						
	standard U	1 V DC	1 V DC		1 V DC	
	max.	1,3 V DC	1,3 V DC		1,3 V DC	
Frequency on inductive load	See Note 1		See Note 1		See Note 1	
Input / Output isolation	2,5 kV		2,5 kV		2,5 kV	
TEMPERATURE						
Storage	- 30°C to + 80°C		- 30°C to + 80°C		- 30°C to + 80°C	
Operating	- 20°C to + 60°C		- 20°C to + 60°C		- 20°C to + 60°C	

MOS output optocoupler plugs

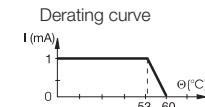
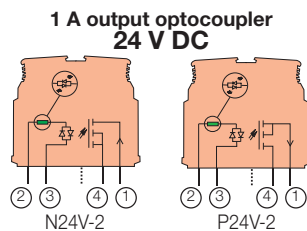
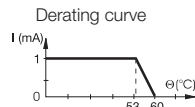
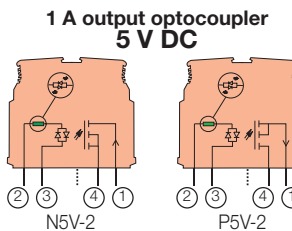
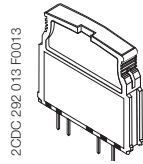

Note 1 :

$$F_{max} = (1 - 0,007 \times U_s) / (L \times I_s^2)$$

or

$$F_{max} = (1 - 0,007 \times U_s) / (P \times \frac{L}{R})$$

U_s = Output voltage supply
 I_s = Output current
 L = Inductive load
 P = Load power
 R = Load resistance

Part numbers	Type	P/N	Type	P/N
	BNMS N5V-2	1SNA031816R0400	BNMS N24V-2	1SNA031817R0500
	BNMS P5V-2	1SNA031818R1600	BNMS P24V-2	1SNA031819R1700
Characteristics				
INPUT				
Voltage	4,5 V to 5,5 V DC		20,4 V to 28,8 V DC	
Max. current	12,5 mA		6,7 mA	
Typical triggering threshold at $I_s=100\%$	3,5 V DC		10 V DC	
Switching time	C/O	20 μ s / 250 μ s	50 μ s / 350 μ s	
Leakage current	1 mA		1 mA	
OUTPUT				
Max. voltage / Max. current	58 V / See graphs		58 V / See graphs	
Residual voltage max. I and rated U				
	standard U	1 V DC	1 V DC	
	max.	1,3 V DC	1,3 V DC	
Frequency on inductive load	See Note 1		See Note 1	
Input / Output isolation	2,5 kV		2,5 kV	
TEMPERATURE				
Storage	- 30°C to + 80°C		- 30°C to + 80°C	
Operating	- 20°C to + 60°C		- 20°C to + 60°C	

MOS output optocoupler plug

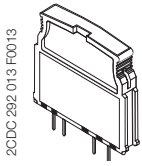

2CDC 292 013 F0013

2 A output optocoupler 5 V DC

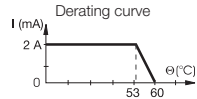
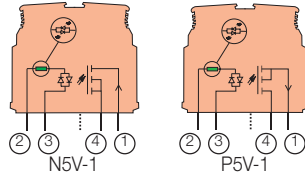

2 A output optocoupler 24 V DC

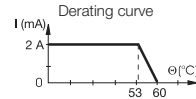
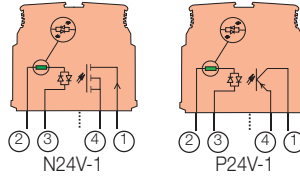

Note 2 :

$$F_{max} = (1 - 0,012 \times U_s) / (L \times I_s^2)$$

or

$$F_{max} = (1 - 0,012 \times U_s) / (P \times \frac{1}{R})$$

U_s = Output voltage supply
I_s = Output current
L = Inductive load
P = Load power
R = Load resistance

Part numbers	Type	P/N	Type	P/N
	BNMS N5V-1	1SNA031812R0000	BNMS N24V-1	1SNA031813R0100
	BNMS P5V-1	1SNA031814R0200	BNMS P24V-1	1SNA031815R0300
Characteristics				
INPUT				
Voltage	4,5 V to 5,5 V DC		20,4 V to 28,8 V DC	
Max. current	12,5 mA		6,7 mA	
Typical triggering threshold	3,5 V DC		10 V DC	
Switching time	C/O	20 μs / 250 μs	50 μs / 350 μs	
Leakage current	1 mA		1 mA	
OUTPUT				
Max. voltage / Max. current	30 V DC / See graphs		30 V / See graphs	
Residual voltage max. I and rated U				
standard U	1 V DC		1 V DC	
max.	1,3 V DC		1,3 V DC	
Frequency on inductive load	See Note 2		See Note 2	
Input / Output isolation	2,5 kV		2,5 kV	
TEMPERATURE				
Storage	- 30°C to + 80°C		- 30°C to + 80°C	
Operating	- 20°C to + 60°C		- 20°C to + 60°C	

Triac output optocoupler plug

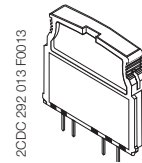

2CDC 292 013 F0013

1 A output optocoupler 24 V DC

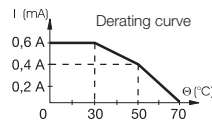
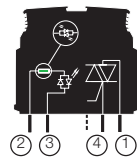

Part numbers	Type	P/N
	BNMS A24V-4	1SNA031839R1300
Characteristics		
INPUT		
Voltage	20,4 V to 28,8 V DC	
Max. current	3,8 mA	
Typical triggering threshold	10 V DC	
Switching time	C/O	9,5 ms / 12 ms
Leakage current		
OUTPUT		
Max. voltage / Max. current	24 V to 253 V AC / See derating curve	
Residual voltage max. I and rated U		
standard U	1 V AC	
max.	1,3 V AC	
Input / Output isolation	2,5 kV	
TEMPERATURE		
Storage	- 30°C to + 80°C	
Operating	- 20°C to + 70°C	

Relay plugs

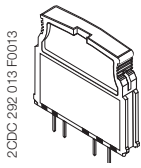

2CDC 292 013 F0013

1 SPDT relay

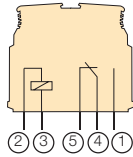

R24V-1

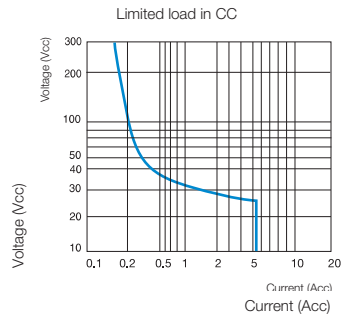
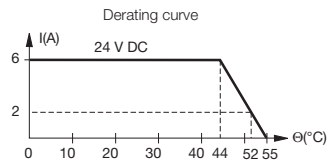

	DC12	AC12	DC13	AC15
24 V	6 A	6 A	1 A	3 A
110/120 V	0,3 A	6 A	0,2 A	3 A
220/230 V	0,2 A	6 A	0,1 A	3 A

Part numbers

Type	P/N
BNMS R24V-1	1SNA031820R1400
BNMS R24V-2	1SNA031847R1300

Characteristics

	BNMS R24V-1	BNMS R24V-2
COIL		
Voltage	20,4 V to 28,8 V DC	
Current max.	7 mA	
Trip voltage	1,2 V	
CONTACT		
Type	1 SPDT	
Voltage mini. / max.	12 V / 250 V	5 V / 250 V
Switching current mini. / max.	10 mA / 6 A	1 mA / 6 A
Switching current AC1 mini. / max.	0,6 VA/1500 VA (resistance)	0,05 VA/1500 VA (resistance)
Switching current DC1 mini. / max.	0,6 W / 140 W	0,05 W / 140 W
Number of operations on load	10 ⁸ operations for AC15	
Number of operations off load	10x10 ⁶ operations	
Operating speed C/O	6 ms / 8 ms	
Bounce	1,5 ms	
Isolation Coil / Contact	4 kV	
Resistance to shock waves Coil / Contact	4 kV	
Isolation Contact / Contact	1 kV	
TEMPERATURE		
Storage	- 40°C to + 80°C	
Operating	- 20°C to + 55°C	

Analogical plugs

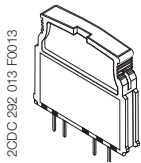

2CDC 292 013 F0013

Current / Voltage Converter

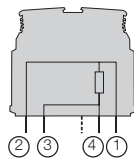

Plug with 250 Ω accuracy resistance for analogical signals.

Current / Voltage Converter

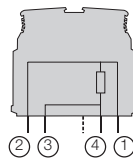

Plug with 500 Ω accuracy resistance for analogical signals.

Part numbers

Type	P/N	Type	P/N
BNMS CA I/U-250	1SNA031832R0400	BNMS CA I/U-500	1SNA031833R0500

Characteristics

	250 Ω	500 Ω
Resistance	250 Ω	500 Ω
Power	0,35 W	0,35 W
Accuracy	0,1 %	0,1 %
Stability	25 ppm	25 ppm

Fuse and strap plugs

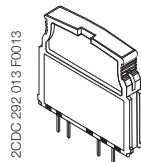

2CDC 292 013 F0013

Output fuse plug

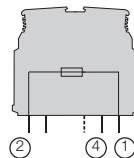

Input fuse plug

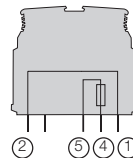

Strap plug

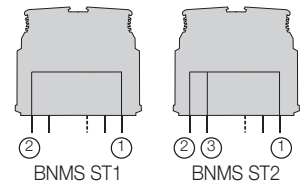

Part numbers

Type	P/N	Type	P/N	Type	P/N
BNMS F125mA-1	125 V / 125 mA 1SNA031821R0100	BNMS F125mA-3	125 V / 125 mA 1SNA031827R0700	BNMS ST1	1SNA031829R1100
BNMS F500mA-1	125 V / 500 mA 1SNA031838R1200	BNMS F125mA-4	250 V / 125 mA 1SNA031828R1000	BNMS ST2	1SNA031830R1600
BNMS F2A-1	125 V / 2 A 1SNA031822R0200				
BNMS F5A-1	125 V / 5 A 1SNA031823R0300				
BNMS F125mA-2	250 V / 125 mA 1SNA031824R0400				
BNMS F2A-2	250 V / 2 A 1SNA031825R0500				
BNMS F5A-2	250 V / 5 A 1SNA031826R0600				



BADL



BAM2

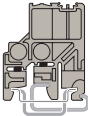

BAMH



BADH



PR30

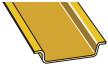

PR3.Z2

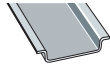

PR3.G2



PR5



PR4



FC2

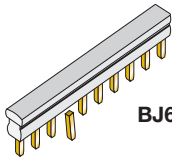

BJ612-...

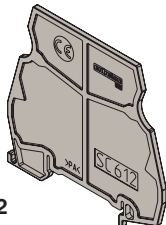

SC612

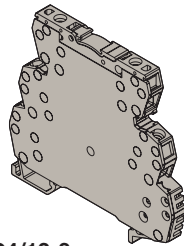

D4/12-3...

End stops

The end stops are mounted at the extremity of the terminal board assembly, giving additional support to the terminal blocks as markers. For various types of marking, refer to the marker section.

Description	Type	Order P/N	Packaging Weight kg	
End stop DIN 3	grey V0	BADL 9 mm	1SNA399903R0200	50
End stop with screws DIN 3	grey V0	BAM2 V0 10 mm	1SNA399967R0100	50
	grey V2	BAM2 10 mm	1SNA206351R1600	50
	beige V0	BAM2 V0 10 mm	1SNA296351R0000	50
High end stop with screws DIN 1 and DIN 3	grey	BAMH 9,1 mm	1SNA114836R0000	50
	beige V0	BAMH V0 9,1 mm	1SNA194836R0100	50
High end stop with screws DIN 3	grey	BADH 12 mm	1SNA116900R2700	50

Mounting rails

Symmetrical zinc bichromate plated steel prepunched rail	PR30	2 m	1SNA173220R0500	1
Symmetrical zinc bichromate plated steel rail	PR3.Z2	2 m	1SNA174300R1700	1
White, symmetrical passivated galvanized steel rail	PR3.G2	2 m	1SNA164800R0300	1
Symmetrical zinc bichromate plated steel rail	PR5	2 m	1SNA168700R2200	1
Symmetrical zinc bichromate plated steel rail	PR4	2 m	1SNA168500R1200	1

Test devices

Test plug DIA. 2 mm	FC2	1SNA007865R2600	10
---------------------	-----	-----------------	----

Assembled jumper bar

This accessory permits electrical connection between 2 to 70 blocks with 6 mm spacing placed side by side. It can be used with screw clamp or spring clamp blocks with 6 mm or 12 mm spacing. Interconnection of blocks not placed side by side is possible if teeth of the jumper bar have been cut in front of the blocks not to be connected. These teeth can be removed using pliers. Use of separator end sections before and after the jumper bar is required to preserve IP20 protection of the assembly.

Assembled jumper bar 10 poles - 24 A	BJ612-10	1SNA290488R0100	10
Assembled jumper bar 20 poles - 24 A	BJ612-20	1SNA206754R0000	10

Separator end section

Directly mounted on the rail beside the block, it permits to identify and make electrical insulation of product groups using jumper bars. Dimensions are the same as screw clamp blocks : width 70 mm and height on rail 67,5 mm with 2 mm spacing.

Separator end section	SC612	1SNA290474R0200	10
-----------------------	-------	-----------------	----

Distribution module

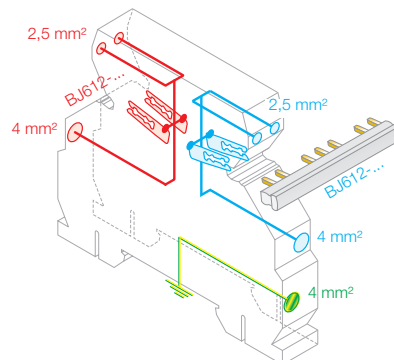

This terminal block with BJ612-... jumper bars permits 2 polarities distribution (PCL side and process side) thanks to two separate circuits, each of them including :

- one 4 mm² input,
- two 2,5 mm² outputs
- one double output for jumper bar BJ612-...

It permits also the connection of ground to the rail though a 4 mm² input.

Rated voltage : 250 VAC-DC
 Rated current : 32 A (4 mm²) - 16 A (2,5 mm²)
 Recommended torque : 0,4 - 0,6 Nm

Screw clamp distribution block sp. 12 mm	D4/12-3-3	1SNA645031R2000	5
Spring clamp distribution block sp. 12 mm	D4/12-3R-3R	1SNA645531R2200	5

Accessories

PCMS

Comb-type jumper

This accessory permits the electrical connection of 2 to 22 blocks.

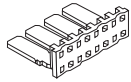

No. of poles	Grey UL94V0	Red UL94V0	Blue UL94V0	Green/Yellow UL94V0
2	1SNA205491R2300	1SNA205492R2400	1SNA205493R2500	1SNA205494R2600
3	1SNA205495R2700	1SNA205496R2800	1SNA205497R2900	1SNA205498R3000
4	1SNA205499R3100	1SNA205500R3200	1SNA205501R3300	1SNA205502R3400
5	1SNA205503R3500	1SNA205504R3600	1SNA205505R3700	1SNA205506R3800
6	1SNA205507R3900	1SNA205508R4000	1SNA205509R4100	1SNA205510R4200
7	1SNA205511R4300	1SNA205512R4400	1SNA205513R4500	1SNA205514R4600
8	1SNA205515R4700	1SNA205516R4800	1SNA205517R4900	1SNA205518R5000
9	1SNA205519R5100	1SNA205520R5200	1SNA205521R5300	1SNA205522R5400
10	1SNA205523R5500	1SNA205524R5600	1SNA205525R5700	1SNA205526R5800
11	1SNA205527R5900	1SNA205528R6000	1SNA205529R6100	1SNA205530R6200
12	1SNA205531R6300	1SNA205532R6400	1SNA205533R6500	1SNA205534R6600
13	1SNA205535R6700	1SNA205536R6800	1SNA205537R6900	1SNA205538R7000
14	1SNA205539R7100	1SNA205540R7200	1SNA205541R7300	1SNA205542R7400
15	1SNA205543R7500	1SNA205544R7600	1SNA205545R7700	1SNA205546R7800
16	1SNA205547R7900	1SNA205548R8000	1SNA205549R8100	1SNA205550R8200
17	1SNA205551R8300	1SNA205552R8400	1SNA205553R8500	1SNA205554R8600
18	1SNA205555R8700	1SNA205556R8800	1SNA205557R8900	1SNA205558R9000
19	1SNA205559R9100	1SNA205560R9200	1SNA205561R9300	1SNA205562R9400
20	1SNA205563R9500	1SNA205564R9600	1SNA205565R9700	1SNA205566R9800
21	1SNA205567R9900	1SNA205568R10000	1SNA205569R10100	1SNA205570R10200
22	1SNA205571R10300	1SNA205572R10400	1SNA205573R10500	1SNA205574R10600

5

PEF

Identification label holders

Designed to hold RPEV label (see opposite).

PEF * 1SNA020568R0400

* Delivered with labels.

The label holders are removable and the labels can be changed easily.

• For mounting on PCB in a 3,7 mm diameter hole.

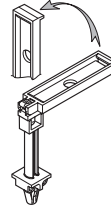

• For mounting on a PCB block in a 2 mm diameter hole (no support leg).

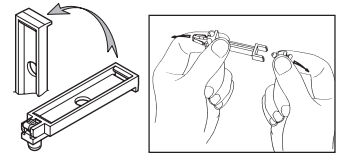

RPEV

Label for PEF 29 x 6 mm

Sheets of 99 pre-cut labels



✓ Blank RPEV 1SNA173178R0700

DC

Test device on screw head

This patented device is mounted on the round screwdriver opening. It is used for trouble shooting, measuring and control for monitoring and repairing an installation, on blocks without a test socket. For this, the device receives an FC2 test plug.

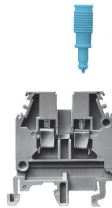

The DC's are differentiated by their colour :

blue for MA 2,5/5 blocks

DCB 1SNA105028R2100

PC

Comb-type jumper bar

PC EIP

This accessory can be used only on the terminal blocks with at least one compression clamp connection. It permits the electrical connection of 2 to 10 blocks.

Interconnection of non-consecutive blocks is possible by removing the teeth opposite the blocks which must not be connected. The comb-type jumper bars can be cut using pliers (or a saw) : in this case, the use of an insulating tip EIP is recommended. The comb is placed in the compression clamp before tightening the screws, above the eventual conductor.

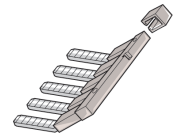
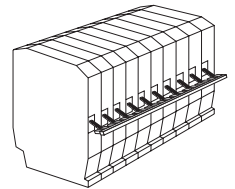

To be mounted on blocks series R900 and R910 :

Insulating tip for comb EIP 1SNA113550R2000
Comb-type jumper bar PC9 15 A 10 poles 1SNA210160R1200

BJ Jumper bar

BJS Jumper bar not assembled

To connect terminal blocks, place the metal tube into the top center hole on each terminal block to be connected.

The metal tube contacts the terminal block's internal connector bar.

The perforated bar is cut to length and placed flat along the center opening of the series of terminal blocks.

The screw is inserted into the perforated bar's hole which is located directly above the blocks being connected. The screw goes through the threaded metal tube and is screwed into the terminal block's internal connector bar. This completes the electrical connection to the perforated bar and connects the block.

To be mounted on blocks series R910 :

Screw + washer + post EV6D 1SNA168400R1600
Perforated jumper bar BJS9 32 A 8 poles 1SNA177583R1200
BJS9 32 A 16 poles 1SNA177584R1300

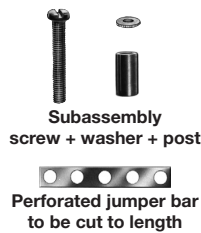

IDC jumper

(insulation displacement jumper)

Characteristics

Wire size mm ² / AWG	Rigid Flexible	IEC NFC VDE		CSA
		2,5 mm ²	14 AWG	
Voltage	V	600	600	
Current	A	26	15	
Rated wire size	mm ² / AWG	2,5 mm ²	14 AWG	
Working temperature	°C	-55°C -> +110°C		
Protection		IP20 / NEMA1		

Quick-jump lets you interconnect screw clamp terminals of different sizes, levels and all manufacturers quickly and safely. Its insulation displacement technology makes it easy to use, fast, economical and does not require a special tool. Use as a jumper between relays, switches and other electronic components. ABB Quick-jump will fit any screw clamp type terminal block, from 6 mm .238" spacing and larger.

How to use : connecting Quick-jump to your terminal

- 1 - Insert ABB Quick-jump into your terminal screw clamp.
- 2 - Tighten the terminal screw.
- 3 - Guide jumper wire through the V-shaped opening in the Quick-jump.
- 4 - Secure the wire by closing the Quick-jump lever with any flat nose pliers.

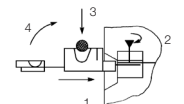

Adding a shunt in an installation :

- 1 - Insert ABB Quick-jump into your terminal screw clamp.
- 2 - Guide the terminal screw clamp into contact with the wire.
- 3 - Secure the wire by closing the Quick-jump lever with any flat nose pliers.
- 4 - Tighten the terminal screw.

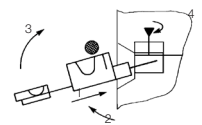

Insulation displacement jumper AD 2,5 1SNA114205R2000

RL Lengthwise marker

RLV Lengthwise marker
Width 9 mm .354"

Large area for writing.
To be snapped onto the top of blocks.

Blank marker for writing : RLV 1SNA103849R0300

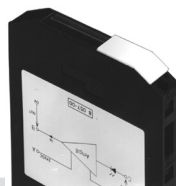

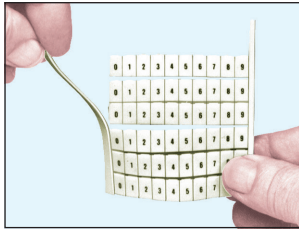

1

Remove one of the side bands of the card.

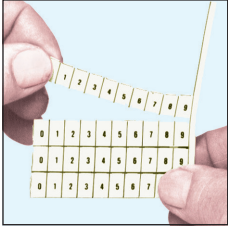

2

Separate the chosen strip from the rest of the card.

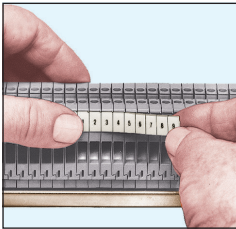

3

Press the first marker in place, hold it and slide your thumb on the rest of the strip.

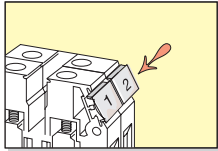

Horizontal marking

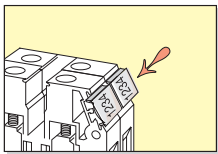

Vertical marking



Refillable box of 100 cards of 18 RC markers

Marking for Interface Modules

Selection table

Markers for modules :	RC610	RC55	RC65
R500			
R600		POSSIBLE	
R900			
R910		POSSIBLE	
R1800			

Possible mounting : **POSSIBLE**

Recommended mounting :

Impossible mounting :

Marking for terminal blocks

Standard RC marker cards

Marker sizes	<div style="display: flex; justify-content: space-around; font-size: small;"> (x) = Nb of cards in 5 mm spacing kit (x) = Nb of cards in 6 mm spacing kit (x) = Nb of cards in 6 mm spacing kit </div>		
	RC55	RC65	RC610
Blank cards	1SNA230000R1200	1SNA232000R0000	1SNA233000R0100
Horizontal marking			
10 strips from 1 to 10	1SNA230002R0000 (5)	1SNA232002R2600 (5)	1SNA233002R2700 (25)
10 strips from 11 to 20	1SNA230003R0100 (2)	1SNA232003R2700 (2)	1SNA233003R2000 (10)
10 strips from 21 to 30	1SNA230004R0200	1SNA232004R2000	1SNA233004R2100 (6)
10 strips from 31 to 40	1SNA230005R0300	1SNA232005R2100	1SNA233005R2200 (4)
10 strips from 41 to 50	1SNA230006R0400	1SNA232006R2200	1SNA233006R2300 (3)
10 strips from 51 to 60	1SNA230007R0500	1SNA232007R2300	1SNA233007R2400 (2)
10 strips from 61 to 70	1SNA230008R1600	1SNA232008R0400	1SNA233008R0500 (2)
From 1 to 100	1SNA230030R0700 (2)	1SNA232030R2500 (2)	1SNA233030R2600 (15)
From 101 to 200	1SNA230031R2400	1SNA232031R1200	1SNA233031R1300 (2)
20 times L1-L2-L3-N-PE	1SNA230131R2500	1SNA232131R1300	1SNA233131R1400 (2)
Vertical marking			
10 strips from 1 to 10	1SNA230041R0600	1SNA232041R2400	1SNA233041R2500 (5)
10 strips from 11 to 20	1SNA230042R0700	1SNA232042R2500	1SNA233042R2600 (3)
10 strips from 21 to 30	1SNA230043R0000	1SNA232043R2600	1SNA233043R2700 (2)
10 strips from 31 to 40	1SNA230044R0100	1SNA232044R2700	1SNA233044R2800 (2)
From 1 to 100	1SNA230060R1500	1SNA232060R0300	1SNA233060R0400 (6)

Marking kit RC 5 mm spacing or 6 mm spacing

Box with 100 cards with 18 various part numbers (see table next page)

Description	Type	Order P/N	Packaging Weight kg
Box with 100 cards RC 5 mm spacing		1SNA400085R2700	1
Refill for box RC 5 mm		1SNA400145R0700	1
Box with 100 cards RC 6 mm spacing		1SNA400084R2600	1
Refill for box RC 6 mm		1SNA400144R0600	1

Panel heaters

Product group picture

6

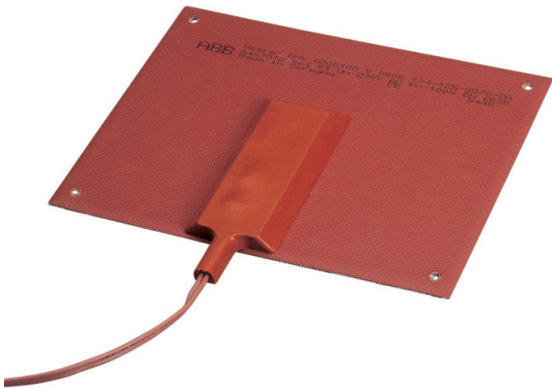
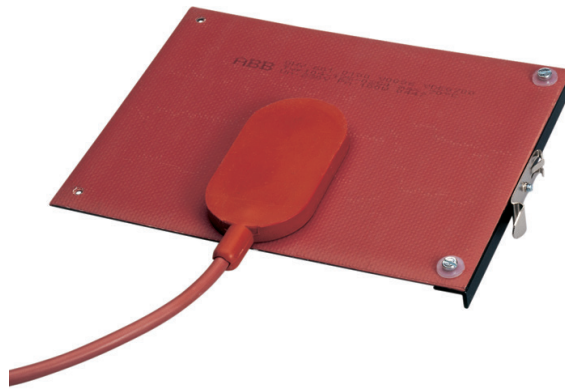
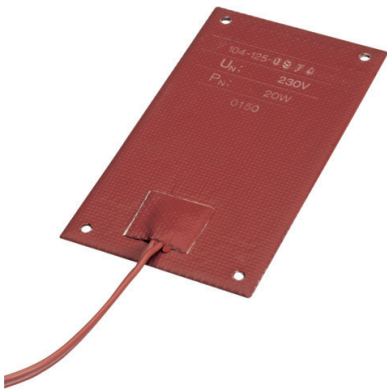

Panel heaters

Table of contents

Panel heaters	
Product group picture	6/1
Table of contents	6/2
Benefits and advantages, heat demand calculation	6/3
Ordering details	6/4
Technical data	6/5
Dimensional drawings, Application note	6/7
Notes	6/8

Panel heaters

Benefits and advantages, heat demand calculation

Why do I need a panel heater?

Whenever the ambient temperature around the control panel exceeds the temperature inside the control panel, condensation may occur inside the control panel. Humidity may be deposited as condensation water on the devices and terminals in the control panel, leading to malfunction and short circuits.

A simple solution is heating the inside of the control panel. This ensures that the temperature inside the control panel is always a little bit higher than the outside temperature, thus avoiding condensation.

To ensure that this does not happen to your control panel or subsidiary distribution box in the winter, we recommend using panel heaters to protect your equipment from frost damages and to ensure the trouble-free functioning of your systems.

ABB's panel heaters are characterized by their flat structural form that enables positive fastening at the control panel wall without disturbing other devices. A mounting clip also enables DIN rail mounting. Each panel heater includes overheating protection.

Fields of application

- Anti-condensation
Avoidance of water condensation inside the control panel (eg. in carpark ticket machines)
- Anti-frost
Avoidance of undercooling of systems and control panels inside of free-standing distributors or mobile equipment.

Features

- Flat structural form: only 3 mm thick
- Rated input power stages stages: 20 W, 40 W, 100 W, 200 W, 250 W, 300 W
- Voltages: 110 V or 230 V, 50/60 Hz
- Plate temperature fixed at +70 °C or +80 °C or adjustable from +30 °C to +150 °C
- Long lifetime through low surface temperature (70 °C or 80 °C)
- Even heat distribution on the whole heating surface
- Good resistance against chemicals
- Isolation out of silicone rubber, continuous 180 °C, puncture-proof until 12 kV/mm
- Bracket: anodized aluminium
- Connecting line: 0.5 m silicone rubber, 2 x 0.75 mm²
- The heating elements are tested in accordance to VDE 720, CEE publication 11
- Lowest ambient temperature -40 °C
- Fastening: Snap on 35 mm top hat rail, optionally fastening with M 4 screws or by bonding
- Separate thermostat for exact temperature control

The panel heaters have to be installed to provide sufficient heat dissipation

Heat demand calculation

The calculation of the heat demand (watt) and the selection of the appropriate heating plate depends on different factors such as:

- size of the control panel
- material of the control panel
- place of installation
- relative humidity
- power dissipation (self-heating) of the chassis-mounted units
- ventilation of the control panel

To aid installation, we have established the guideline values on the right.

case content in litres	Location		
	indoors heated	indoors unheated	outdoors
up to 20	10 W	20 W	40 W
30	20 W	33 W	55 W
50	30 W	55 W	90 W
75	30 W	75 W	130 W
100	55 W	90 W	150 W
120	55 W	90 W	150 W
160	55 W	130 W	180 W
240	90 W	180 W	235 W
300	90 W	180 W	275 W
420	90 W	180 W	310 W
500	90 W	240 W	360 W
600	90 W	280 W	415 W
800	130 W	280 W	630 W
1000	130 W	280 W	810 W
1200	150 W	360 W	1300 W

Panel heaters

Ordering details

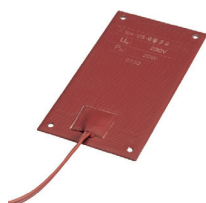

2CDC 311 001 F0005

Heating element 20 W¹⁾



2CDC 311 012 F0005

Heating element 250 W¹⁾



2CDC 311 010 F0005

Heating plate 100 W¹⁾ adjustable



2CDC 311 005 F0005

Mounting clips



2CDC 311 0016 F0005

Thermostat

Ordering details

Rated input power	Rated operational voltage	Plate temperature	Cable length	Type	Order code	Price	Pkg qty	Weight (1 pce) kg (lb)
20 W	230 V AC	max. 80 °C	0.5 m	20W-230V-HE	GHV6000020V0006		1	0.10 (0.22)
40 W				40W-230V-HE	GHV6000040V0006			0.25 (0.55)
100 W		100W-230V-HE		GHV6000100V0006		0.30 (0.66)		
200 W	max. 70 °C	200W-230V-HE		GHV6000200V0006		0.50 (1.10)		
300 W		300W-230V-HE		GHV6000300V0006		0.50 (1.10)		
40 W		40W-110V-HP		GHV6000040V0004		0.13 (0.29)		
40 W	230 V AC	70 °C fixed	0.5 m	40W-230V-HP	GHV6010040V0006		1	0.13 (0.29)
100 W	110 V AC			100W-110V-HP	GHV6010100V0004			0.37 (0.80)
100 W	230 V AC			100W-230V-HP	GHV6010100V0006			0.37 (0.80)
250 W	110 V AC			250W-110V-HP	GHV6010250V0004			0.58 (1.28)
250 W	230 V AC			250W-230V-HP	GHV6010250V0006			0.54 (1.19)
40 W	230 V AC			70 °C fixed	3 m	40W-230V-HP-E		GHV6010040V0007
100 W		100W-230V-HP-E	GHV6010100V0007				0.37 (0.80)	
100 W		100W-230V-HP-ADJ	GHV6017100V0006				0.39 (0.85)	
250 W	230 V AC	adjustable from 30-150 °C	-	250W-230V-HP-ADJ	GHV6017250V0006		1	0.54 (1.19)

¹⁾ Rated input power

Ordering details - Accessories

Description	Type	Order code	Price	Pkg qty	Weight (1 pce) kg (lb)
Mounting clips for heating elements to snap on DIN rail (Heating Power 20-100W)	20-100W-MC	GHV6000000V0001		1	0.01 (0.22)
Mounting clips for heating elements to snap on DIN rail (Heating Power 200-300W)	200-300W-MC	GHV6000000V0002		1	0.02 (0.44)
Thermostat with rated operational voltage 230 V AC (Temperature adjustable from 10 to 60 °C)	Thermostat	GHV6011060V0001		1	0.25 (0.55)

Panel heaters

Technical data

Data at $T_a = 25\text{ °C}$ and rated values, if noting else indicated.

Type		20W-230V-HE	40W-230V-HE	100W-230V-HE	200W-230V-HE	300W-230V-HE
Input circuit - supply circuit						
Rated operational voltage		230 V AC				
Operational voltage range		210-240 V AC/DC				
Rated frequency		50/60 Hz				
Frequency range		DC; 47-63 Hz				
Typical current / power consumption	230 V AC	87 mA / 20 VA	170 mA / 40 VA	439 mA / 100 VA	870 mA / 200 VA	1300 mA / 300 VA
	110 V AC	-	-	-	-	-
Typical inrush current		87 mA	170 mA	430 mA	870 mA	1300 mA
Output circuit						
Heating element		silicone heating element				
Bracket of the heating element		anodized aluminium				
Isolation of the heating element		silicone				
Maximum peak heating power ¹⁾		20 W	40 W	100 W	200 W	300 W
Maximum plate temperature		80 °C			70 °C	
Plate temperature adjustable		no				
Power density		0.17 W/cm ²	0.13 W/cm ²	0.33 W/cm ²		0.5 W/cm ²
General data						
Duty time		100 %				
Mounting		screw, bond, DIN rail (optional)				
Degree of protection		IP53				
Electrical connection						
Connecting line out of silicone rubber		2x0.75 mm ² (2x18 AWG)				
Length of connecting line		0.5 m				
Environmental data						
Ambient temperature range	operation	-40...+20 °C			-40...+40 °C	
	storage	-60...+100 °C				
	transport	-60...+100 °C				
Standards						
Product standard		DIN EN 60335-1, DIN EN 60335-1 (VDE 0700-1):2007-02, EN 60335-1:2002+ A11+ A1+ A12+ Corr.+ A2:2006				
Low Voltage Directive		2006/95/EC				

¹⁾Maximum peak heating power = Rated input power

Panel heaters

Technical data

Data at $T_a = 25\text{ °C}$ and rated values, if noting else indicated.

Type	40W-110V-HP	40W-230V-HP	40W-230V-HP-E	100W-110V-HP	100W-230V-HP	100W-230V-HP-E	250W-110V-HP	250W-230V-HP	100W-230V-HP-ADJ	250W-230V-HP-ADJ
Input circuit - supply circuit										
Rated operational voltage	110 V AC	230 V AC		110 V AC	230 V AC		110 V AC	230 V AC		
Rated voltage range	105-115 V AC	210-240 V AC		105-115 V AC	210-240 V AC		105-115 V AC	210-240 V AC		
Rated frequency	50/60 Hz									
Frequency range	47-63 Hz									
Typical current / power consumption	230 V AC	-	170 mA / 40 VA	-	430 mA / 100 VA	-	1086 mA / 250 VA	430 mA / 100 VA	1086 mA / 250 VA	
	110 V AC	360 mA / 40 VA	-	910 mA / 100 VA	-	2270 mA / 250 VA	-	-	-	
Typical inrush current	360 mA	170 mA	910 mA	430 mA	2270 mA	1086 mA	430 mA	1086 mA		
Output circuit										
Heating element	silicone heating element									
Bracket of the heating element	anodized aluminium									
Isolation of the heating element	silicone									
Maximum peak heating power ¹⁾	40 W		100 W			250 W		100 W	250 W	
Maximum plate temperature	70 °C								150 °C	
Plate temperature adjustable	no								yes, +30...+150 °C	
Power density	0.33 W/cm ²					0.42 W/cm ²		0.33 W/cm ²	0.42 W/cm ²	
General data										
Duty time	100 %									
Mounting	screw, bond, DIN rail									
Degree of protection	IP53									
Electrical connection										
Connecting line out of silicone rubber	2x0.75 mm ² (2x18 AWG)									
Length of connecting line	0.5 m									
Environmental data										
Ambient temperature range	operation	-40...+40 °C								
	storage	-60...+100 °C								
	transport	-60...+100 °C								
Standards										
Product standard	DIN EN 60335-1, DIN EN 60335-1 (VDE 0700-1):2007-02, EN 60335-1:2002+ A11+ A1+ A12+ Corr.+ A2:2006									
Low Voltage Directive	2006/95/EC									

¹⁾Maximum peak heating power = Rated input power

Panel heaters

Dimensional drawings, Application note

Table of dimensions

in mm

Type	L	L1	L2	B	B1	B2	H	H1	H2	Drawing no.
Heating elements for screw mounting, optionally DIN rail mounting with mounting clips										
20W-230V-HE	150	134	65	80	64	32	2.5	10	-	2
40W-230V-HE	150	130	65	200	180	45	2.5	10	-	1
100W-230V-HE	150	130	65	200	180	45	2.5	10	-	1
200W-230V-HE	300	280	95	200	180	45	2.5	10	-	2
300W-230V-HE	300	280	95	200	180	45	2.5	10	-	2
Heating plates, temperature fixed, with mounting clip for DIN rail mounting										
40W-110V-HP 40W-230V-HP 40W-230V-HP-E	150	134	65	80	64	32	2.5	10	-	2
100W-110V-HP 100W-230V-HP 100W-230V-HP-E	150	130	65	200	180	45	2.5	10	-	1
250W-110V-HP 250W-230V-HP	300	280	85	200	180	45	2.5	10	-	2
Heating plates, temperature adjustable from 30 to 150 °C, with mounting clip for DIN rail mounting										
100W-230V-HP-ADJ	150	130	65	200	180	45	2.5	10	50	1
250W-230V-HP-ADJ	300	280	85	200	180	45	2.5	10	50	2

6

Dimensions

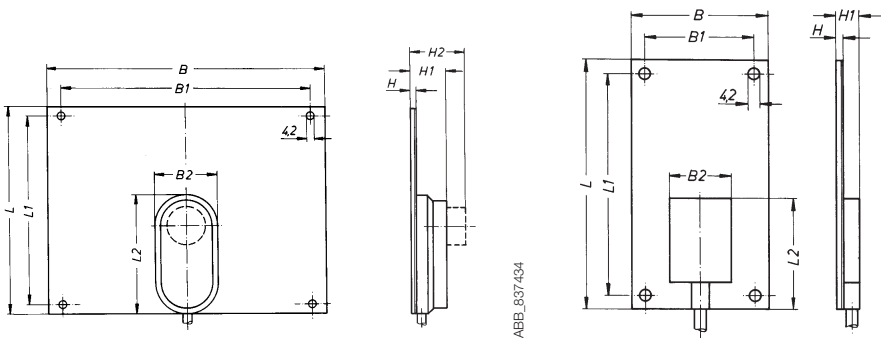

Dimensional drawing 1

Dimensional drawing 2

Application note

The panel heaters regulate their surface temperature themselves. Depending on the environmental conditions and the heat dissipation, the heating power could therefore be smaller than the electrical peak input power.

Panel heaters

Notes

Blank lined area for notes.

Logic relays

Product group picture

7



Logic relays

Table of contents

Logic relays	
Product group picture	7/1
Table of contents	7/2
System overview	7/3
Approvals and marks	7/5
Ordering details - Stand alone logic relays	7/6
Ordering details - Expandable logic relays	7/7
Ordering details	7/8
Ordering details - Display systems	7/9
Technical data	7/10
Dimensional drawings	7/24

Logic relays

System overview

Concept

CL range logic relays are suitable for small and medium-sized control tasks and are able to substitute logic wiring in a quick and simple manner.

They can be used for applications in control as well as for timing functions, e. g.

- in buildings, lighting systems, air-conditioning systems, general control functions,
- in small machines and systems or
- as stand-alone control module for small applications.

Steps to the application of CL range

- CL range can be used easily, rapidly and comfortably without any time-consuming planning and programming.
- The user can discover the advantages and the benefit of these logic relays in no time at all.
- CL range provides for the control statements according to a simple circuit diagram.
- Setup, storage, simulation and documentation are performed using the compact and user-friendly CL-SOFT software (CL-LAS.PS002).

Software characteristics (CL-SOFT)

- display on a PC monitor according to IEC, ANSI
- different languages to choose from
- easy installation on all Microsoft Windows™ operating systems

Logic links instead of wiring

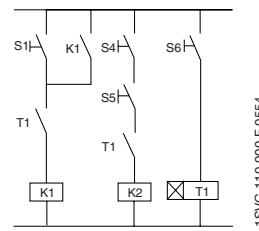

Documentation (download from the internet)

Logic relay manual	1SVC 440 795 M0100
Remote display manual	1SVC 440 795 M2100
Display system manual	1SVC 440 795 M1100

7

Technical Data overview

Logic relays

- 8 or 12 digital inputs
- 4 or 6 digital relay outputs
- optionally with 4 or 8 transistor outputs
- 128 rungs
- 3 contacts as n/o or n/c contacts in series plus 1 coil per rung
- optionally with 2 or 4 analog inputs (not 100-240 V AC version)
- power flow display for checking the circuit diagram (devices with display)
- expansions for local or remote level
- enclosure color RAL 7035
- DIN rail mounting

Remote display

- Remote display up to a distance of 5 m
- Illustration of text and status displays
- Remote adjustment via keypad
- Front panel mounting

Display system

- useable as compact HMI logic relay
- fully graphic, backlit display module
- 12 digital inputs
- 4 digital relay outputs
- optionally with 4 transistor outputs
- 256 rungs
- 4 contacts as n/o or n/c contacts in series plus 1 coil per rung
- optionally with 4 analog inputs (not 100-240 V AC version)
- networking-compatible via CL-NET
- front panel mounting
- expansion for local

Software

- 16 timing relays 0.01-99:59 h
- 16 counting relays for up-, down counting
- 8 weekly timer, 8 annual timers
- 16 analog value comparators
- 16 freely editable display texts
- 32 markers or auxiliary relays

Logic relays

System overview

Logic relays

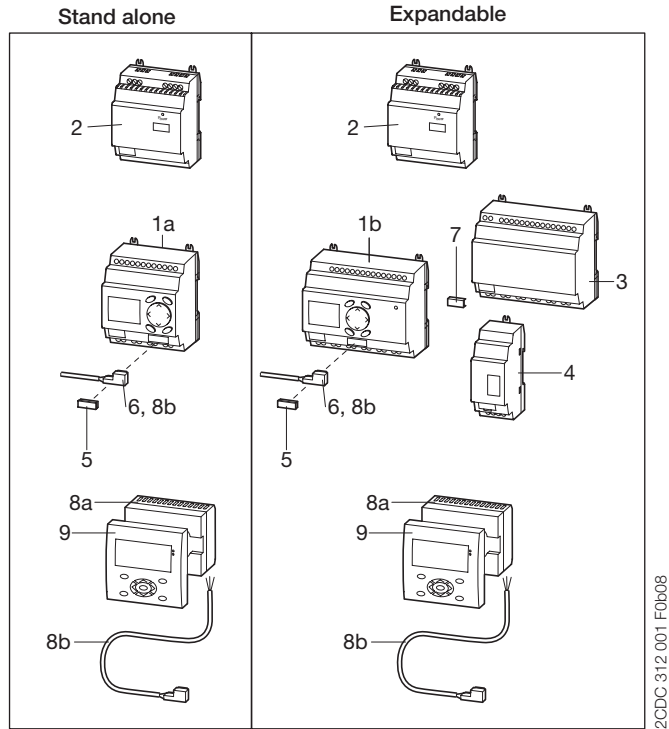

- 1a Logic relay CL-LS..
- 1b Expandable logic relay CL-LM..
- 2 Power supply CP-D...
- 3 I/O expansion CL-LER..., CL-LET.. for logic relays CL-LM..
- 4 Coupler unit CL-LEC.. for remote expansion of logic relays CL-LM..
- 5 Memory module CL-LAS.MD003 for logic relays CL-LS., CL-LM..
- 6 Connecting cable CL-LAS.TK001, CL-LAS.TK002 to connect PC
- 7 CL-LINK plug CL-LAS.TK011 to connect expansion to logic relays CL-LM..
- 8a Remote display connection module CL-LDC.S..
- 8b Connecting cable CL-LAD.TK007 to connect a remote displays to a logic relay
- 9 Display module CL-LDD..

Expansion of logic relays*

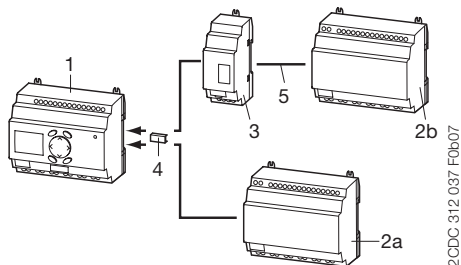

- 1 Logic relay CL-LM..
- 2 I/O expansion CL-LER..., CL-LET..
 - 2a local expansion
 - 2b remote expansion
- 3 Coupler unit CL-LEC.. for remote expansion of logic relays CL-LM..
- 4 CL-LINK plug CL-LAS.TK011 for expansion of logic relays CL-LM..
- 5 up to 30 m

* max. 1 expansion per logic relay

Display system → Compact HMI logic relay

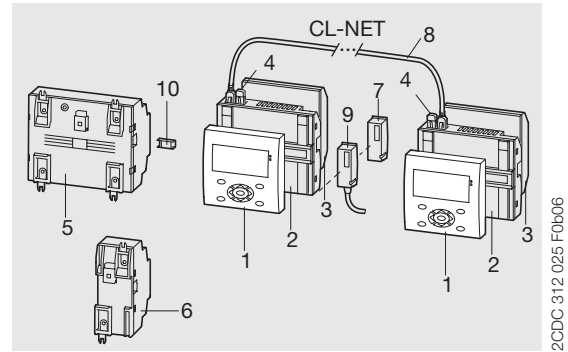

- 1 Display module CL-LDD..
 - 2 Display base module CL-LDC.LN..
 - 3 Display I/O module CL-LDR..., CL-LDT..
 - 4 Termination resistor CL-LAD.TK009
 - 5 I/O expansion CL-LER..., CL-LET..
 - 6 Coupler unit CL-LEC.. for remote expansion
 - 7 Memory module CL-LAD.MD004 for display base module
 - 8 Connecting cable CL-LAD.TK002, CL-LAD.TK003, CL-LAD.TK004
 - 9 Connecting cable CL-LAD.TK001, CL-LAD.TK011 to connect PC
 - 10 CL-LINK plug CL-LAS.TK011 for expansion of logic relays CL-LM..
- e.g. door of switchgear cabinet

Stand alone with I/O module

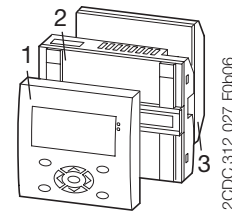

- 1 Display CL-LDD..
- 2 Remote display connection module CL-LDC.S.. incl. connecting cable
- 3 Display base module CL-LDC.L..

Communication via CL-NET

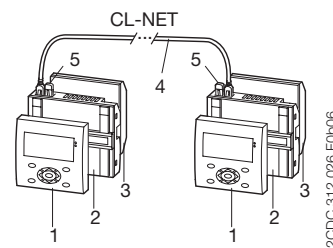









- 1 Display CL-LDD..
- 2 Display base module CL-LDC.LN.. for CL-NET
- 3 Display I/O module CL-LDR..., CL-LDT..
- 4 Connecting cable CL-LAD.TK002, CL-LAD.TK003, CL-LAD.TK004
- 5 Termination resistor CL-LAD.TK009

Logic relays

Approvals and marks

- existing
- pending

		Logic relays				Expansions			Display system				Accessories	
		CL-LSR	CL-LST	CL-LMR	CL-LMT	CL-LER	CL-LET	CL-LEC	CL-LDD	CL-LDC	CL-LDR	CL-LDT	CL-LAS	CL-LAD
Approvals														
	UL	■	■	■	■	■	■	■	■	■	■	■	■ ¹⁾	■ ²⁾
	CAN/CSA C22.2 No.14	■	■	■	■	■	■	■	■	■	■	■	■ ¹⁾	■ ²⁾
	CAN/CSA C22.2 No.213 (hazardous locations)	■	■	■	■	■	■	■	■	■	■	■	■ ¹⁾	■ ²⁾
	GL	■	■	■	■				■	■ ³⁾	■ ⁴⁾	■		
	GOST	■ ⁵⁾	■ ⁵⁾	■ ⁵⁾	■ ⁵⁾	■ ⁵⁾	■ ⁵⁾	■ ⁵⁾	■ ⁵⁾	■ ⁵⁾	■ ⁵⁾	■ ⁵⁾	■ ⁵⁾	■ ⁵⁾
	Lloyds Register	■	■	■	■				■	■ ³⁾	■ ⁴⁾	■		
Marks														
	CE	■	■	■	■	■	■	■	■	■	■	■	■	■
	C-Tick	□	□	□	□	□	□	□	□	□	□	□	□	□

7

¹⁾ not for: CL-LAS-PS002, CL-LAS.TD001, CL-LAS.FD001, CL-LAS.TK002, CL-LAS.TK011

²⁾ not for: CL-LAD.TK006, CL-LAD.TK011, CL-LAD.FD002

³⁾ not for: CL-LDC.SDC2, CL-LDC.SAC2, CL-LDC.LAC2, CL-LDC.LNAC2

⁴⁾ not for: CL-LDR.16AC2

⁵⁾ May have been replaced by EAC during the availability of this catalog edition

Logic relays

Ordering details - Stand alone logic relays



2CDC 281 034 F0006

CL-LSR



2CDC 281 033 F0006

CL-LST

Ordering details - Logic relays stand alone

Rated operational voltage	Display + Keypad	Timer	Input / Output	Type	Order code	Price 1 pce	Weight (1 pce) kg (lb)
24 V AC	■	■	8 inputs / 4 relay outputs	CL-LSR.C12AC1	1SVR440712R0300		0.20 (0.44)
				CL-LSR.CX12AC1	1SVR440712R0200		
100-240 V AC	■	■		CL-LSR.12AC2	1SVR440713R0100		
				CL-LSR.C12AC2	1SVR440713R0300		
12 V DC	■	■		CL-LSR.CX12AC2	1SVR440713R0200		
				CL-LSR.C12DC1	1SVR440710R0300		
24 V DC	■	■		CL-LSR.CX12DC1	1SVR440710R0200		
				CL-LSR.12DC2	1SVR440711R0100		
24 V DC	■	■		CL-LSR.C12DC2	1SVR440711R0300		
				CL-LSR.CX12DC2	1SVR440711R0200		
24 V DC	■	■	8 inputs / 4 transistor outputs	CL-LST.C12DC2	1SVR440711R1300		
				CL-LST.CX12DC2	1SVR440711R1200		

Ordering details - Display modules

Rated operational voltage	Description	Type	Order code	Price 1 pce	Weight (1 pce) kg (lb)
-	Graphic display 132 x 64 pixel	CL-LDD.XK	1SVR440839R4500		0.14 (0.30)
-	Graphic display 132 x 64 pixel, with keypad	CL-LDD.K	1SVR440839R4400		0.13 (0.29)
24 V DC	Module to displace the display from the logic relay, incl. connecting cable CL-LAD.	CL-LDC.SDC2	1SVR440841R0000		0.16 (0.36)
100-240 V DC	TK007, 5m, length adaptable	CL-LDC.SAC2	1SVR440843R0000		0.16 (0.36)



2CDC 281 028 F0006

CL-LDD.K



2CDC 281 017 F0007

CL-LDC.S..

Logic relays

Ordering details - Expandable logic relays



CL-LMR

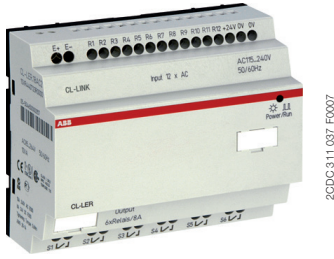

CL-LER



CL-LEC

Ordering details - Logic relays expandable

Rated operational voltage	Display + Keypad	Timer	Input / Output	Type	Order code	Price 1 pce	Weight (1 pce) kg (lb)
24 V AC	■	■	12 inputs / 6 relay outputs	CL-LMR.C18AC1	1SVR440722R0300		0.36 (0.79)
100-240 V AC	■	■		CL-LMR.CX18AC1	1SVR440722R0200		
				CL-LMR.C18AC2	1SVR440723R0300		
12 V DC	■	■		CL-LMR.CX18AC2	1SVR440723R0200		
				CL-LMR.C18DC1	1SVR440720R0300		
24 V DC	■	■		CL-LMR.CX18DC1	1SVR440720R0200		
			CL-LMR.C18DC2	1SVR440721R0300			
24 V DC	■	■	CL-LMR.CX18DC2	1SVR440721R0200			
			CL-LMT.C20DC2	1SVR440721R1300		0.36 (0.79)	
24 V DC	■	■	12 inputs, 8 transistor outputs	CL-LMT.CX20DC2	1SVR440721R1200		

Ordering details - Expansions

Rated operational voltage	Description	Type	Order code	Price 1 pce	Weight (1 pce) kg (lb)
-	2 relay outputs	CL-LER.20	1SVR440709R5000		0.07 (0.15)
100-240 V AC	12 inputs, 6 relay outputs	CL-LER.18AC2	1SVR440723R0000		0.26 (0.57)
24 V DC		CL-LER.18DC2	1SVR440721R0000		0.22 (0.49)
24 V DC	12 inputs, 8 transistor outputs	CL-LET.20DC2	1SVR440721R1000		0.21 (0.46)
-	Coupler unit for remote expansion with a distance of up to 30 m	CL-LEC.CI000	1SVR440709R0000		0.07 (0.15)

Logic relays

Ordering details



CL-LAS.PS002



CL-LAS.TK001



CL-LAS.MD003

2CDC311 012 F0007

2CDC311 014 F0007

2CDC311 013 F0007

Ordering details - CL-LA...

Description	Type	Order code	Price 1 pce	Weight (1 pce) kg (lb)
Software for programming and control of CL range devices. Installation CD-ROM for Microsoft Windows™.	CL-LAS.PS002	1SVR440799R8000		0.10 (0.21)
Memory module for logic relays Memory size: 32 kB	CL-LAS.MD003	1SVR440799R7000		0.02 (0.04)
Cable with serial interface to connect PC and logic relay. Length: 2 m	CL-LAS.TK001	1SVR440799R6000		0.10 (0.22)
Cable with USB interface to connect PC and logic relay. Length: 2 m	CL-LAS.TK002	1SVR440799R6100		0.06 (0.13)
Cable for point-to-point connection of remote-display connection module and logic relay, length: 5m, adaptable	CL-LAD.TK007	1SVR440899R6600		0.20 (0.44)
Fixing brackets for screw mounting of logic relay, expansion, display base module	CL-LAS.FD001	1SVR440799R5000		0.01 (0.01)
Spare plug (CL-LINK) for connection of logic relay to expansion	CL-LAS.TK011	1SVR440799R5100		0.10 (0.22)
Primary switch mode power supplies, Rated input voltage: 100-240 V AC Rated output voltage/current: 24 V DC / 0.42 A	CP-D 24/0.42 ¹⁾	1SVR427041R0000		0.06 (0.13)
Primary switch mode power supplies, Rated input voltage: 100-240 V AC Rated output voltage/current: 24 V DC / 1.3 A	CP-D 24/1.3 ²⁾	1SVR427043R0100		0.19 (0.41)

¹⁾ replaces CL-LAS.SD001, technical data see chapter "Primary switch mode power supplies"

²⁾ replaces CL-LAS.SD002, technical data see chapter "Primary switch mode power supplies"

Logic relays

Ordering details - Display systems



CL-LDD.K

2CDC 311 028 F0006

Ordering details - Display systems

Rated operational voltage	Description	Type	Order code	Price 1 pce	Weight (1 pce) kg (lb)
-	Display module Graphic display 132 x 64 pixel	CL-LDD.XK	1SVR440839R4500		0.14 (0.30)
-	Display module Graphic display 132 x 64 pixel, with keypad	CL-LDD.K	1SVR440839R4400		0.13 (0.29)
24 V DC	Display base module	CL-LDC.LDC2	1SVR440821R0000		0.16 (0.36)
100-240 V AC	CPU / power supply	CL-LDC.LAC2	1SVR440823R0000		
24 V DC	Display base module	CL-LDC.LNDC2	1SVR440821R1000		0.17 (0.38)
100-240 V AC	CPU / power supply, networking-compatible (CL-NET)	CL-LDC.LNAC2	1SVR440823R1000		
100-240 V AC	Display I/O module	CL-LDR.16AC2	1SVR440853R0000		0.17 (0.38)
24 V DC	12 inputs, 4 relay outputs	CL-LDR.16DC2	1SVR440851R0000		
24 V DC	Display I/O module 12 inputs, 4 relay outputs, 1 analog output	CL-LDR.17DC2	1SVR440851R2000		0.17 (0.38)
24 V DC	Display I/O module 12 inputs, 4 transistor outputs	CL-LDT.16DC2	1SVR440851R1000		0.14 (0.30)
24 V DC	Display I/O module 12 inputs, 4 transistor outputs, 1 analog output	CL-LDT.17DC2	1SVR440851R3000		0.14 (0.30)



CL-LDC.LN.

2CDC 311 031 F0006

7



CL-LAD.MD004

2CDC 311 018 F0007

Ordering details - CL-LAD...

Description	Type	Order code	Price 1 pce	Weight (1 pce) kg (lb)
Memory module for display base modules Memory size: 256 kB	CL-LAD.MD004	1SVR440899R7000		0.02 (0.03)
Cable with serial interface to connect PC and display base module	CL-LAD.TK001	1SVR440899R6000		0.11 (0.23)
Cable with USB interface to connect PC and display base module	CL-LAD.TK011	1SVR440899R6700		
Network cable (CL-NET) to connect 2 display base modules Length: 0.3 m	CL-LAD.TK002	1SVR440899R6100		0.05 (0.12)
Network cable (CL-NET) to connect 2 display base modules Length: 0.8 m	CL-LAD.TK003	1SVR440899R6200		0.07 (0.14)
Network cable (CL-NET) to connect 2 display base modules Length: 1.5 m	CL-LAD.TK004	1SVR440899R6300		0.08 (0.18)
Cable for point-to-point connection of remote display connection modules and display base module, length adaptable, Length: 5 m	CL-LAD.TK005	1SVR440899R6400		0.20 (0.44)
Cable for point-to-point connection of 2 display base modules, length adaptable. Length: 5 m	CL-LAD.TK006	1SVR440899R6500		0.12 (0.26)
Termination resistor, content: 2 pieces	CL-LAD.TK009	1SVR440899R6900		0.01 (0.02)
Protective cover, transparent, for harsh environmental conditions and application in the food industry	CL-LAD.FD001	1SVR440899R1000		0.03 (0.07)
Protective cover, transparent and sealable	CL-LAD.FD011	1SVR440899R2000		0.03 (0.07)
Assembly tool for mounting of display modules	CL-LAD.FD002	1SVR440899R3000		



CL-LAD.TK001

2CDC 311 019 F0007



CL-LAD.TK002

2CDC 311 020 F0006

Logic relays

Technical data

Data at $T_a = 25\text{ °C}$ and rated values, if nothing else indicated.

Type	CL-LSR.C...12DC1	CL-LSR...12DC2 CL-LST.C...12DC2	CL-LSR.C...12AC1	CL-LSR...12AC2
Input circuit - supply circuit				
Rated operational voltage U_n	12 V DC	24 V DC	24 V AC	100-240 V AC
Rated operational voltage tolerance	-15...+30 %	-15...+20 %	-15...+10 %	-
Operational voltage range	10.2-15.6 V DC	20.4-28.8 V DC	20.4-26.4 V AC	85-264 V AC
Rated frequency	0 Hz	-	50/60 Hz	-
Rated frequency tolerance	-	-	±5 %	-
Residual ripple	≤ 5 %	-	-	-
Input current	at 12 V DC typ. 140 mA	-	-	-
	at 24 V DC -	typ. 80 mA	-	-
	at 24 V AC -	-	typ. 200 mA	-
	at 115/120 V AC (60 Hz) -	-	-	typ. 40 mA
	at 230/240 V AC (50 Hz) -	-	-	typ. 20 mA
Power failure buffering (IEC/EN 61131-2)	10 ms	-	20 ms	-
Power dissipation	at 12 V DC typ. 2 W	-	-	-
	at 24 V DC -	typ. 2 W	-	-
	at 24 V AC -	-	typ. 5 VA	-
	at 115/120 V AC -	-	-	typ. 5 VA
	at 230/240 V AC -	-	-	typ. 5 VA

Type	CL-LMR.C...18DC1	CL-LMR.C...18DC2 CL-LMT.C...20DC2	CL-LMR.C...18AC1	CL-LMR.C...18AC2
Input circuit - supply circuit				
Rated operational voltage U_n	12 V DC	24 V DC	24 V AC	100-240 V AC
Rated operational voltage tolerance	-15...+30 %	-15...+20 %	-15...+10 %	-
Operational voltage range	10.2-15.6 V DC	20.4-28.8 V DC	20.4-26.4 V AC	85-264 V AC
Rated frequency	0 Hz	-	50/60 Hz	-
Rated frequency tolerance	-	-	±5 %	-
Residual ripple	≤ 5 %	-	-	-
Input current	at 12 V DC typ. 200 mA	-	-	-
	at 24 V DC -	typ. 140 mA	-	-
	at 24 V AC -	-	typ. 300 mA	-
	at 115/120 V AC (60 Hz) -	-	-	typ. 70 mA
	at 230/240 V AC (50 Hz) -	-	-	typ. 35 mA
Power failure buffering (IEC/EN 61131-2)	10 ms	-	20 ms	-
Power dissipation	at 12 V DC typ. 3.5 W	-	-	-
	at 24 V DC -	typ. 3.5 W	-	-
	at 24 V AC -	-	typ. 7 VA	-
	at 115/120 V AC -	-	-	typ. 10 VA
	at 230/240 V AC -	-	-	typ. 10 VA

Type	CL-LER.18DC2 CL-LET.20DC2	CL-LER.18AC2		
Input circuit - supply circuit				
Rated operational voltage U_n	24 V DC	100-240 V AC		
Rated operational voltage tolerance	-15...+20 %	-15...+10 %		
Operational voltage range	20.4-28.8 V DC	85-264 V AC		
Rated frequency	0 Hz	50/60 Hz		
Rated frequency tolerance	-	±5 %		
Residual ripple	≤ 5 %	-		
Input current	at 24 V DC typ. 140 mA	-		
	at 115/120 V AC (60 Hz) -	typ. 70 mA		
	at 230/240 V AC (50 Hz) -	typ. 35 mA		
Power failure buffering (IEC/EN 61131-2)	10 ms	20 ms		
Power dissipation	at 24 V DC typ. 3.4 W	-		
	at 115/120 V AC -	typ. 10 VA		
	at 230/240 V AC -	typ. 10 VA		

Logic relays

Technical data

Data at $T_a = 25\text{ °C}$ and rated values, if nothing else indicated.

Type		CL-LSR.C...12DC1	CL-LSR....12DC2 CL-LST.C...12DC2	CL-LSR.C...12AC1	CL-LSR.C...12AC2
Input circuit - Digital inputs					
		12 V DC	24 V DC	24 V AC	115 / 230 V AC
Number		8			
Inputs can be used as analog inputs		2 (I7, I8)			
Indication of operational states		LCD-Display (if existing)			
Electrical isolation	from voltage supply	no			
	between digital inputs	no			
	from the outputs	yes			
Rated operational voltage U_o		12 V DC	24 V DC	24 V AC	
	U_o on „0“ signal	4 V DC (I1-I8)	< 5 V DC (I1-I8)	0-6 V AC (sinusoidal)	
	U_o on „1“ signal	8 V DC (I1-I8)	> 15 V DC (I1-I6), > 8 V DC (I7, I8)	> 9,5 V DC, 14-26,4 V AC (sinusoidal) (I1-I6), > 7 V AC (sinusoidal) (I7,I8)	
Rated frequency			50-60 Hz		
Input current on „1“ signal		3.3 mA (at 12 V DC, I1-I6), 1.1 mA (at 12 V DC, I7, I8)	3.3 mA (at 24 V DC, I6-I7), 2.2 mA (at 24 V DC, I7, I8)	4 mA (at 24 V AC, 50 Hz, I1-I6), 2 mA (at 24 V AC, 50 Hz, I7,I8), 2 mA (at 24 V DC, I7, I8)	6x0.25 mA (at 115 V AC, 60 Hz, I1-I6), 6x0.5 mA (at 230 V AC, 50 Hz, I1-I6) 2x4 mA (at 115 V AC, 60 Hz, I7, I8), 2x6 mA (at 230 V AC, 50 Hz, I7, I8)
Time delay from „0“ to „1“	debounce ON	20 ms		80 ms (at 50 Hz), 66 ² / ₃ ms (at 60 Hz)	
	debounce OFF	typ. 0.3 ms (I1-I6), typ. 0.35 ms (I7, I8)	typ. 0.25 ms (I1-I8)	20 ms (at 50 Hz), 16 ² / ₃ ms (at 60 Hz)	
Time delay from „1“ to „0“	debounce ON	20 ms		80 ms (at 50 Hz), 66 ² / ₃ ms (at 60 Hz)	80 ms (at 50 Hz, I1-I6), 66 ² / ₃ ms (at 60 Hz, I1-I6) 160 ms (at 50 Hz, I7, I8), 150 ms (at 60 Hz, I7, I8)
	debounce OFF	typ. 0.3 ms (I1-I6), typ. 0.15 ms (I7, I8)	-	20 ms (at 50 Hz), 16 ² / ₃ ms (at 60 Hz)	20 ms (at 50 Hz, I1-I6), 16 ² / ₃ ms (at 60 Hz, I1-I6) 100 ms (at 50 Hz, I7, I8), 100 ms (at 60 Hz, I7, I8)
Cable length (unshielded)		100 m		-	-
Maximum cable length per input		-		40 m	40 m (I1-I6), 100 m (I7, I8)
Frequency counter	Number	2 (I3, I4)			
	counting frequency	< 1 kHz			
	pulse shape	square-wave			
	pulse / pause ratio	1:1			
Rapid counter inputs	Number	2 (I1, I2)			
	counting frequency	< 1 kHz			
	pulse shape	square-wave			
	pulse / pause ratio	1:1			
Cable length (shielded)		< 20 m		-	-
Input circuit - Analog inputs					
Number		2 (I7, I8)			
Electrical isolation	from voltage supply	no			
	from the digital inputs	no			
	from the outputs	yes			
	from PC interface, memory module, CL-NET, CL-LINK	no			
Input type		DC voltage			
Signal range		0-10 V DC			
Resolution	analog	0.01 V			
	digital	0.01 V; 10 Bit (value 1-1023)			
Input impedance		11.2 kΩ			
Accuracy of the actual value	two CL devices	±3 %			
	within one device	±2 %, ±0.12 V			
Conversion time analog/digital	Input delay ON	20 ms			
	Input delay OFF	each cycle			
Input current		< 1 mA			
Cable length (shielded)		< 30 m			

Logic relays

Technical data

Data at $T_a = 25\text{ °C}$ and rated values, if nothing else indicated.

Type		CL-LMR.C...18DC1	CL-LMR.C...18DC2 CL-LMT.C...20DC2	CL-LMR.C...18AC1	CL-LMR.C...18AC2
Input circuit - Digital inputs		12 V DC		24 V DC	24 V AC
Number		12			
Inputs can be used as analog inputs		4 (I7, I8, I11, I12)			-
Indication of operational states		LCD-Display (if existing)			
Electrical isolation	from voltage supply	no			
	between digital inputs	no			
	from the outputs	yes			
	from PC interface, memory module, CL-NET, CL-LINK	no			yes
Rated operational voltage U_o		12 V DC	24 V DC	24 V AC	
	U_o on „0“ signal	4 V DC (I1-I12)	< 5 V DC (I1-I12, R1-R12)	0-6 V AC (sinusoidal)	0-40 V AC (sinusoidal)
	U_o on „1“ signal	8 V DC (I1-I12)	> 15 V DC (I1-I6, I9, I10) > 8 V DC (I7, I8, I11, I12)	> 9.5 V DC, 14-26.4 V AC (sinusoidal) (I1-I6, I9, I10) > 7 V AC (sinusoidal) (I7, I8, I11, I12)	79-264 V AC (sinusoidal)
Rated frequency				50-60 Hz	
Input current on „1“ signal		3.3 mA (at 12 V DC, I1-I6, I9-I12), 1.1 mA (at 12 V DC, I7, I8)	3.3 mA (at 24 V DC, I1-I6, I9, I10), 2.2 mA (at 24 V DC, I7, I8, I11, I12)	4 mA (at 24 V AC, 50 Hz, I1-I6, I9, I10), 2 mA (at 24 V AC, 50 Hz, I7, I8, I11, I12), 2 mA (at 24 V DC, I7, I8, I11, I12)	6x0.25 mA (at 115 V AC, 60 Hz, I1-I6), 6x0.5 mA (at 230 V AC, 50 Hz, I1-I6) 2x4 mA (at 115 V AC, 60 Hz, I7, I8), 2x6 mA (at 230 V AC, 50 Hz, I7, I8), 4x0.25 mA (at 115 V AC, 60 Hz, I9-I12), 4x0.5 mA (at 230 V AC, 50 Hz, I9-I12)
Time delay from „0“ to „1“	debounce ON	20 ms		80 ms (at 50 Hz), 66 ² / ₃ ms (at 60 Hz)	
	debounce OFF	typ. 0.3 ms (I1-I6, I9, I10), typ. 0.35 ms (I7, I8, I11, I12)	typ. 0.25 ms	20 ms (at 50 Hz), 16 ² / ₃ ms (at 60 Hz)	
Time delay from „1“ to „0“	debounce ON	20 ms		80 ms (at 50 Hz), 66 ² / ₃ ms (at 60 Hz)	
	debounce OFF	typ. 0.4 ms (I1-I6, I9, I10), typ. 0.35 ms (I7, I8, I11, I12)	-	20 ms (at 50 Hz), 16 ² / ₃ ms (at 60 Hz)	
Cable length (unshielded)		100 m			
Maximum cable length per input				max. 40 m, typ. 40 m (I9, I10)	typ. 40 m (I1-I6, I9-I12), typ. 100 m (I7, I8)
Frequency counter	number	2 (I3, I4)		-	-
	counting frequency	< 1 kHz		-	-
	pulse shape	square-wave		-	-
	pulse / pause ratio	1:1		-	-
Rapid counter inputs	number	2 (I1, I2)		-	-
	counting frequency	< 1 kHz		-	-
	pulse shape	square-wave		-	-
	pulse / pause ratio	1:1		-	-
Cable length (shielded)		< 20 m			
Input circuit - Analog inputs					
Number		4 (I7, I8, I11, I12)			-
Electrical isolation	from voltage supply	no			-
	from the digital inputs	no			-
	from the outputs	yes			-
	from PC interface, memory module, CL-NET, CL-LINK	no			-
Input type		DC voltage			-
Signal range		0-10 V DC			-
Resolution	analog	0.01 V			-
	digital	0.01 V; 10 Bit (value 1-1023)			-
Input impedance		11.2 kΩ			-
Accuracy of the actual value	two CL devices	±3 %			-
	within one device	±2 %, ±0.12 V			-
Conversion time analog/digital	Input delay ON	20 ms			-
	Input delay OFF	each cycle			-
Input current		< 1 mA			-
Cable length (shielded)		< 30 m			-

Logic relays

Technical data

Data at $T_a = 25\text{ °C}$ and rated values, if nothing else indicated.

Type		CL-LER.18DC2 CL-LET.20DC2	CL-LER.18AC2
Input circuit - Digital inputs		24 V DC	115 / 230 V AC
Number		12	
Inputs can be used as analog inputs		-	
Indication of operational states		-	
Electrical isolation	from voltage supply	no	
	between digital inputs	no	
	from the outputs	yes	
	from PC interface, memory module, CL-NET, CL-LINK	no	
Rated operational voltage U_o		24 V DC	
	U_o on „0“ signal	< 5 V DC (I1-I12, R1-R12)	0-40 V AC (sinusoidal)
	U_o on „1“ signal	-	79-264 V AC (sinusoidal)
Rated frequency		-	50-60 Hz
Input current on „1“ signal			12x0.25 mA
		3.3 mA (at 24 V DC, R1-R12)	(at 115 V AC, 60 Hz, R1-R12), 12x0.5 mA (at 230 V AC, 50 Hz, R1-R12)
Time delay from „0“ to „1“	debounce ON	20 ms	80 ms (at 50 Hz, I1-I12, R1-R12), 66 ² / ₃ ms (at 60 Hz, I1-I12, R1-R12)
	debounce OFF	typ. 0.25 ms (R1-R12)	20 ms (at 50 Hz, I1-I12, R1-R12), 16 ² / ₃ ms (at 60 Hz, I1-I12, R1-R12)
Time delay from „1“ to „0“	debounce ON	20 ms	80 ms (at 50 Hz, I1-I12, R1-R12), 66 ² / ₃ ms (at 60 Hz, I1-I12, R1-R12)
	debounce OFF	-	20 ms (at 50 Hz, I1-I12, R1-R12), 16 ² / ₃ ms (at 60 Hz, I1-I12, R1-R12)
Cable length (unshielded)		100 m	-
Maximum cable length per input		-	typ. 40 m (I1-I6, I9-I12, R1-R12), typ. 100 m (I7, I8)

7

Logic relays

Technical data

Data at $T_a = 25\text{ °C}$ and rated values, if nothing else indicated.

Type	CL-LSR...	CL-LMR... CL-LER...	CL-LER.20
Output circuit - Relay outputs			
Number	4	6	2
Outputs in groups of	1		2
Parallel switching of outputs to increase capacity	not permissible		
Fusing of the output relay	circuit-breaker B16 or fuse 8 A (slow-acting)		
Electrical isolation	from voltage supply	yes	
	from the inputs	yes	
	from PC interface, memory module, CL-NET, CL-LINK	no	
	protective separation	300 V AC	
	basic isolation	600 V AC	
Mechanical lifetime	10x10 ⁶ switching cycles		
Rung	conventional thermal current (10 A UL)	8 A	
	recommended for load 12 V AC/DC	> 500 mA	
	short-circuit proof $\cos \varphi = 1$; characteristic B16 at 600 A	16 A	
	short-circuit proof $\cos \varphi = 0,5$ up to 0,7; characteristic B16 at 900 A	16 A	
	Rated impulse withstand voltage U_{imp} contact-coil	6 kV	
	Rated operational voltage U_R	250 V AC	
Rated insulation voltage U_i	250 V AC		
Protective separation (EN 50178)	between coil and contact	300 V AC	
	between two contacts	300V AC	
Making capacity	AC15, 250 V AC, 3 A (600 ops./h)	300.000 switching cycles	
	DC13, L/R ≤ 150 ms, 24 V DC, 1 A (500 ops./h)	200.000 switching cycles	
Breaking capacity	AC15, 250 V AC, 3 A (600 ops./h)	300.000 switching cycles	
	DC13, L/R ≤ 150 ms, 24 V DC, 1 A (500 ops./h)	200.000 switching cycles	
Incandescent lamp load	1000 W at 230/240 V AC	25.000 switching cycles	
	500 W at 115/120 V AC	25.000 switching cycles	
Fluorescent lamp load	10 x 58 W at 230/240 V AC with electrical control gear	25.000 switching cycles	
	10 x 58 W at 230/240 V AC uncompensated	25.000 switching cycles	
	1 x 58 W at 230/240 V AC conventional compensated	25.000 switching cycles	
Switching frequency	mechanical operations	10x10 ⁶	
	switching frequency	10 Hz	
	resistive load / lamp load	2 Hz	
	inductive load	0.5 Hz	
UL/CSA			
Continuous current at 240 V	10 A AC		
Continuous current at 24 V	8 A DC		
AC	Utilization category (Control Circuit Rating Codes)	B 300 Light Pilot Duty	
	max. rated operational voltage	300 V AC	
	max. continuous thermal current $\cos \varphi = 1$ at B 300	5 A	
	max. making / breaking apparent power (Make/Break) $\cos \varphi \neq 1$ at B 300	3600/360 VA	
DC	Utilization category (Control Circuit Rating Codes)	R 300 Light Pilot Duty	
	max. rated operational voltage	300 V DC	
	max. continuous thermal current at R 300	1 A	
	max. making / breaking apparent power (Make/Break) at R 300	28/28 VA	

Logic relays

Technical data

Data at $T_a = 25\text{ °C}$ and rated values, if nothing else indicated.

Type	CL-LST...	CL-LMT...	CL-LET...	
Output circuit - Transistor outputs				
Number	4	8		
Rated operational voltage U_o	24 V DC			
Operational voltage range	20.4-28.8 V DC			
Residual ripple	≤ 5 %			
Supply current	on „0“ signal	typ. 9 mA / max. 16 mA	typ. 18 mA / max. 32 mA	
	on „1“ signal	typ. 12 mA / max. 22 mA	typ. 24 mA / max. 44 mA	
Reverse voltage protection	yes (Attention: If supply voltage is reversed, applying voltage at the outputs, causes a short circuit.)			
Electrical isolation	from voltage supply	yes		
	from the inputs	yes		
	from PC interface, memory module, CL-NET, CL-LINK	-		
Rated operational current I_o on „1“ signal DC	max. 0.5 A			
Lamp load without R_v	5 W			
Residual current on „0“ signal per channel	< 0.1 mA			
Max. output voltage	on „0“ signal at external load < 10 M Ω	2.5 V		
	on „1“ signal at $I_o = 0.5$ A	$U = U_o - 1$ V		
Short-circuit protection	yes, thermal (analysis results from diagnosis input I16, I15; R15, R16)			
Short-circuit tripping current for $R_v \leq 10$ m Ω	0.7 A $\leq I_o \leq 2$ A per output			
Total short-circuit current	8 A	16 A		
Peak short-circuit current	16 A	32 A		
Thermal tripping	yes			
Max. switching frequency with constant resistive load $R_L < 100$ k Ω (depending on active channels and their load)	40.000 switching cycles/h			
Parallel connection of outputs	with resistive load, inductive load with external suppressor, combination within one group	group 1: Q1-Q4	group 1: Q1-Q4, group 2: Q5-Q8	group 1: S1-S4, group 2: S5-S8
	number of outputs	max. 4		
	max. total current	2 A (Attention! Outputs must be actuated simultaneously and for the same length of time.)		
Indication of operational states of the outputs	LCD-Display (if existing)			
Inductive load ¹⁾ without external suppressor				
$T_{0.95} = 1$ ms, $R = 48$ Ω , $L = 16$ mH	utilization factor	0.25 g		
	duty time	100 %		
	max. switching frequency $f = 0.5$ Hz (max. duty time = 50 %)	1500 switching cycles		
DC13, $T_{0.95} = 72$ ms, $R = 48$ Ω , $L = 1.15$ H	utilization factor	0.25 g		
	duty time	100 %		
	max. switching frequency $f = 0.5$ Hz (max. duty time = 50 %)	1500 switching cycles		
$T_{0.95} = 15$ ms, $R = 48$ Ω , $L = 0.24$ H	utilization factor	0.25 g		
	duty time	100 %		
	max. switching frequency $f = 0.5$ Hz (max. duty time = 50 %)	1500 switching cycles		
Inductive load ¹⁾ with external suppressor				
	demand factor	1 g		
	duty time	100 %		
	max. switching frequency max. duty time	depends on suppressor		

¹⁾ For inductive loading, without external suppression of the transistor outputs, the following applies:
 $T_{0.95}$ = time in ms, until 95 % of the steady-state current is achieved. $T_{0.95} \cdot 3 \times T_{0.65} = 3 \times L/R$.

Data transfer rate in the CL-NET network: bus lengths of 40 m and over only attainable with cables with additional cross-section and connection adapter.

Logic relays

Technical data

Data at $T_a = 25\text{ °C}$ and rated values, if nothing else indicated.

Type	CL-LSR..., CL-LST...	CL-LMR... CL-LMT... CL-LET., CL-LER.18..	CL-LER.20 CL-LEC.CI000
General data			
Dimensions (W x H x D)	71.5 mm x 90 mm x 58 mm (2.81 inch x 3.54 inch x 2.28 inch)	107.5 mm x 90 mm x 58 mm (4.23 inch x 3.54 inch x 2.28 inch)	35.5 mm x 90 mm x 58 mm (1.40 inch x 3.54 inch x 2.28 inch)
Weight	0.2 kg (0.44 lb)	0.3 kg (0.66 lb)	0.07 kg (0.15 lb)
Mounting	DIN rail (IEC/EN 60715), 35 mm or screw mounting with fixing brackets CL-LAS.FD001 (accessories)		
Mounting position	horizontal / vertical		
Electrical connection			
Wire size	rigid fine-strand with wire end ferrule	0.2-4 mm ² (22-12 AWG) 0.2-2.5 mm ² (22-12 AWG)	
Max. tightening torque	0.6 Nm		
Environmental data			
Ambient temperature range	operation storage	-25...+55 °C, cold acc. to IEC 60068-2-1, heat acc. to IEC 60068-2-2 -40...+70 °C	
LCD-Display (clearly legible)	0...+55 °C		
Condensation	avoid condensation with suitable methods		
Humidity, no condensation (IEC/EN 60068-2-30)	5-95 %		
Air pressure (operation)	795-1080 hPa		
Degree of protection (IEC/EN 60529)	IP20		
Vibration (IEC/EN 60068-2-6)	10-57 Hz (constant amplitude 0.15 mm), 57-150 Hz (constant acceleration 2 g)		
Shock resistance (half-sine 15 g / 11 ms) (IEC/EN 60068-2-27)	18 Shocks		
Drop (IEC/EN 60068-2-31) height of fall	50 mm		
Free fall, packaged (IEC/EN 60068-2-32)	1 m		
Insulation data			
Overvoltage category	II		
Pollution degree (DIN EN 60947)	2		
Rating of air and creepage distances	EN 50178, UL 508, CSA C22.2, No. 142		
Insulation resistance	EN 50178		
Standards			
Standards and directives	EN 55011, EN 55022, IEC/EN 61000-4, IEC 60068-2-6, IEC 60068-2-27		
Electromagnetic compatibility			
Interference immunity			
electrostatic discharge (ESD)	IEC/EN 61000-4-2	Level 3 (air discharge 8 kV, contact discharge 6 kV)	
electromag. field (HF radiation resistance)	IEC/EN 61000-4-3	10 V/m	
fast transients (Burst)	IEC/EN 61000-4-4	Level 3 (supply cable 2 kV, signal lines 2 kV)	
powerful impulses (Surge)	IEC/EN 61000-4-5	supply cable symmetrical (AC) 2 kV, Level 2 (supply cable symmetrical (DC) 0.5 kV)	
HF line emission	IEC/EN 61000-4-6	10 V	
Interference suppression (EN 55011, EN 55022)	class B		
Real time clock			
Back-up time	see diagram		-
Accuracy	typ. ±5 (±0.5 h/year)		-
Repeat accuracy of the time relay			
Accuracy (from value)	±1		-
Resolution	range „S“	10 ms	-
	range „M:S“	1 s	-
	range „H:M“	1 min	-
Retention behaviour			
Write cycles of retention memory (minimum)	1.000.000 (10 ⁶)		-

Technical diagram

Back-up time of the real time clock

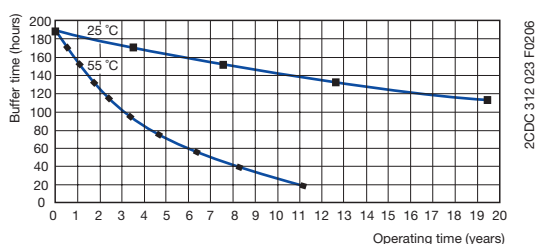

Logic relays

Technical data

Data at $T_a = 25\text{ °C}$ and rated values, if nothing else indicated.

Type	CL-LDD...	
Input circuit - Supply circuit		
Power failure buffering (IEC/EN 61131-2)		10 ms
General data		
Dimensions (W x H x D)		with keypad: 86.5 x 86.5 x 21.5 mm (3.41 x 3.41 x 0.85 inch) without keypad: 86.5 x 86.5 x 20 mm (3.41 x 3.41 x 0.79 inch)
Weight		0.13 kg (0.29 lb)
Mounting		2 x 22.5 mm, with 2 retainers screwed
Mounting position		horizontal / vertical
Environmental data		
Ambient temperature range	operation	-25...+55 °C (cold acc. to IEC 60068-2-1, heat acc. to IEC 60068-2-2)
	storage	-40...+70 °C
LCD-Display (clearly legible)		-5...+50 °C, -10...0 °C (with backlit / continuous operation)
Condensation		avoid condensation with suitable methods
Humidity, no condensation (IEC/EN 60068-2-30)		5-95 %
Air pressure (operation)		795-1080 hPa
Degree of protection (IEC/EN 60529)		IP65
Vibration (IEC/EN 60068-2-6)		10-57 Hz (constant amplitude 0.15 mm), 57-150 Hz (constant acceleration 2 g)
Shock resistance (half-sine 15 g / 11 ms) (IEC/EN 60068-2-27)		18 Shocks
Drop (IEC/EN 60068-2-31) height of fall		50 mm
Free fall, packaged (IEC/EN 60068-2-32)		1 m
Insulation data		
Pollution degree (DIN EN 60947)		3
Rating of air and creepage distances		EN 50178, UL 508, CSA 22.2, No 142
Insulation resistance		EN 50178
Standards		
Standards and directives		EN 61000-6-1, EN 61000-6-2, EN 61000-6-3, EN 61000-6-4, IEC 60068-2-6, IEC 60068-2-27
Electromagnetic compatibility		
Interference immunity		
electrostatic discharge (ESD)	IEC/EN 61000-4-2	Level 3 (air discharge 8 kV, contact discharge 6 kV)
electromag. field (HF radiation resistance)	IEC/EN 61000-4-3	10 V/m
fast transients (Burst)	IEC/EN 61000-4-4	Level 3 (supply cable 2 kV, signal lines 2 kV)
powerful impulses (Surge)	IEC/EN 61000-4-5	Level 3 (supply cable symmetrical 2 kV, CL-LDC.L...AC2)
		Level 2 (0.5 kV supply cable symmetrical, CL-LDC.L...AC2)
HF line emission	IEC/EN 61000-4-6	10 V
Interference suppression (EN 55011, EN 55022)		class B

Logic relays

Technical data

Data at $T_a = 25\text{ °C}$ and rated values, if nothing else indicated.

Type		CL-LDC.SDC2	CL-LDC.SAC2	CL-LDC.LDC2	CL-LCD.LAC2	CL-LDC.LNDC2	CL-LDC.LNAC2
Input circuit - Supply circuit							
Rated operational voltage U_n		24 V DC	100-240 V AC	24 V DC	100-240 V AC	24 V DC	100-240 V AC
Rated operational voltage tolerance		-15...+20 %	-15...+10 %	-15...+20 %	-15...+10 %	-15...+20 %	-15...+10 %
Operational voltage range		20.4-28.8 V DC	85-264 V AC	20.4-28.8 V DC	85-264 V AC	20.4-28.8 V DC	85-264 V AC
Frequency		0 Hz	50/60 Hz	0 Hz	50/60 Hz	0 Hz	50/60 Hz
Frequency tolerance		-	± 5 %	-	± 5 %	-	± 5 %
Residual ripple		≤ 5 %	-	≤ 5 %	-	≤ 5 %	-
Input current	at 24 V DC	typ. 185 mA	-	typ. 200 mA	-	typ. 200 mA	-
	at 115/120 V AC (60 Hz)	-	typ. 90 mA	-	typ. 90 mA	-	typ. 90 mA
	at 230/240 V AC (50 Hz)	-	typ. 60 mA	-	typ. 60 mA	-	typ. 60 mA
Power failure buffering (IEC/EN 61131-2)		10 ms	-	-	-	-	-
Power dissipation	at 24 V DC	1.5 W	-	3.4 W	-	3.4 W	-
	at 115/120 V AC	-	typ. 11 VA	-	typ. 11 VA	-	typ. 11 VA
	at 230/240 V AC	-	typ. 15 VA	-	typ. 15 VA	-	typ. 15 VA
Network - point-to-point connection							
Number of stations		1	-	-	-	-	-
Data transfer rate	CL-LS..., CL-LM...	9,6 kBaud	-	-	-	-	-
	CL-LDD	19,2 kBaud	-	-	-	-	-
Distance		max. 5 m	-	-	-	-	-
Electrical isolation	to voltage supply	yes	-	-	-	-	-
	to connected device	yes	-	-	-	-	-
Termination system		spring-type terminal	-	-	-	-	-
Network - CL-NET							
Number of stations		max. 1	-	-	-	max. 8	-
Data transfer rate	6 m	-	-	-	-	1000 kBit/s	-
	25 m	-	-	-	-	500 kBit/s	-
	40 m	-	-	-	-	250 kBit/s	-
	125 m	-	-	-	-	125 kBit/s	-
	300 m	-	-	-	-	50 kBit/s	-
	700 m	-	-	-	-	20 kBit/s	-
	1000 m	-	-	-	-	10 kBit/s	-
Electrical isolation	to voltage supply	-	-	-	-	yes	-
	to inputs	-	-	-	-	yes	-
	to outputs	-	-	-	-	yes	-
	to PC interface, memory module, CL-NET, CL-LINK	-	-	-	-	yes	-
Bus terminator (first and last station)		-	-	-	-	yes	-
Termination system		-	-	-	-	RJ45, 8 pole	-
General data							
Dimensions (W x H x D)		75 x 58 x 36.2 mm (2.95 x 2.28 x 1.43 inch)		107.5 x 90 x 30 mm (4.23 x 3.54 x 1.18 inch)			
Weight		0.164 kg (0.36 lb)		0.145 kg (0.32 lb)			
Mounting		plugged onto CL-LDD		plugged onto CL-LDD or on DIN rail (IEC/EN 60715)			
Mounting position							
Electrical connection - Supply circuit							
Wire size	fine-strand with wire end ferrule	0.2 mm ² / 2.5 mm ² (24-12 AWG)					
	rigid	0.2 mm ² / 4 mm ² (24-12 AWG)					
Electrical connection - Data cable							
Wire size	fine-strand with wire end ferrule	0.08 mm ² / 1.5 mm ² (28-12 AWG)	-	-	-	0.2 mm ² / 2.5 mm ² (24-12 AWG)	
	rigid	0.08 mm ² / 2.5 mm ² (28-12 AWG)	-	-	-	0.2 mm ² / 4 mm ² (24-12 AWG)	
Environmental data							
Ambient temperature range	operation	-25...+55 °C (cold acc. to IEC 60068-2-1, heat acc. to IEC 60068-2-2)					
	storage	-40...+70 °C					
Condensation		avoid condensation with suitable methods					
Humidity, no condensation (IEC/EN 60068-2-30)		5-95 %					
Air pressure (operation)		795-1080 hPa					
Degree of protection (IEC/EN 60529)		IP20					
Vibration (IEC/EN 60068-2-6)		10-57 Hz (constant amplitude 0.15 mm), 57-150 Hz (constant acceleration 2 g)					

Logic relays

Technical data

Data at $T_a = 25\text{ °C}$ and rated values, if nothing else indicated.

Type	CL-LDC.SDC2	CL-LDC.SAC2	CL-LDC.LDC2	CL-LCD.LAC2	CL-LDC.LNDC2	CL-LDC.LNAC2
Shock (half-sine 15 g / 11 ms) (IEC/EN 60068-2-27)	18 Shocks					
Drop (IEC/EN 60068-2-31) height of fall	50 mm					
Free fall, packaged (IEC/EN 60068-2-32)	1 m					
Insulation data						
Degree of protection (DIN EN 60947)	2					
Rating of air and creepage distances	EN 50178, UL 508, CSA 22.2, No 142					
Isolation resistance	EN 50178					
Standards						
Standards and directives	EN 61000-6-1, EN 61000-6-2, EN 61000-6-3, EN 61000-6-4, IEC 60068-2-6, IEC 60068-2-27					
Electromagnetical compatibility						
Interference immunity						
electrostatic discharge (ESD)	IEC/EN 61000-4-2	Level 3 (air discharge 8 kV, contact discharge 6 kV)				
electromag. field (HF radiation resistance)	IEC/EN 61000-4-3	10 V/m				
fast transients (Burst)	IEC/EN 61000-4-4	Level 3 (supply cable 2 kV, signal lines 2 kV)				
powerful impulses (Surge)	IEC/EN 61000-4-5	Level 3 (supply cable symmetrical 2 kV, CL-LDC.L...AC2) Level 2 (1 kV supply cable symmetrical) Level 2 (0.5 kV supply cable symmetrical, CL-LDC.L...AC2)				
HF line emission	IEC/EN 61000-4-6	10 V				
Interference suppression (EN 55011, EN 55022)	class B					
Real time clock						
Back-up time	-		see diagram			
Accuracy	-		typ. ± 5 s/day ($\pm 0,5$ h/year)			
Repeat accuracy of the time relay						
Accuracy (from value)	-		$\pm 0.02\%$			
Resolution	range „S“	-		5 ms		
	range „M:S“	-		1 s		
	range „H:M“	-		1 min		
Retention behaviour						
Write cycles of retention memory (minimum)	-		10^{10} (read/ write cycles)			

7

Technical diagram

Back-up time of the real time clock

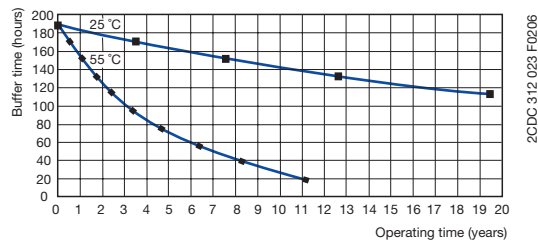

Logic relays

Technical data

Data at $T_a = 25\text{ °C}$ and rated values, if nothing else indicated.

Type		CL-LD...16DC2	CL-LD...17DC2	CL-LDR.16AC2	
Input circuit - Digital inputs		24 V DC		115/230 V	
Number		12			
Inputs can be used as analog inputs		4 (I7, I8, I11, I12)		-	
Indication of operational states		-		LCD-Display (if existing)	
Electrical isolation	from supply voltage	no			
	from digital inputs	no			
	from the outputs	yes			
	from PC interface, memory module, CL-NET, CL-LINK	yes			
Rated operational voltage U_o		24 V DC		-	
	U_o on „0“ signal	< 5 V DC (I1-I6, I9, I10), < 8 V DC (I7, I8, I11, I12)		0-40 V AC (sinusoidal)	
	U_o on „1“ signal	> 15 V DC (I1-I6, I9, I10), > 8 V DC (I7, I8, I11, I12)		79-264 V AC (sinusoidal)	
Rated frequency		0 Hz		50-60 Hz	
Input current on „1“ signal		3.3 mA (at 24 V DC, I1-I6, I9, I10), 2.2 mA (at 24 V DC, I7, I8, I11, I12)		12x0.2 mA (at 115 V AC, 60 Hz, I1-I12), 12x0.5 mA (at 230 V AC, 50 Hz, I1-I12)	
	Time delay from „0“ to „1“	debounce ON	20 ms		10 ms (at 50 Hz), 100 ms (at 60 Hz)
		debounce OFF	typ. 0.1 ms (I1-I4), typ. 0.25 ms (I5-I12)		10 ms (at 50 Hz), 100 ms (at 60 Hz)
Time delay from „1“ to „0“		debounce ON	20 ms		10 ms (at 50 Hz), 100 ms (at 60 Hz)
		debounce OFF	typ. 0.1 ms (I1-I4), typ. 0.4 ms (I5, I6, I9, I10), typ. 0.2 ms (I7, I8, I11, I12)		10 ms (at 50 Hz), 100 ms (at 60 Hz)
Cable length (unshielded)		100 m		-	
Maximum cable length per input		-		typ. 60 m	
Frequency counter	number	4 (I1, I2, I3, I4)		-	
	counting frequency	< 3 kHz		-	
	pulse shape	square-wave		-	
	pulse / pause ratio	1:1		-	
Incremental counter	number	2 (I1 + I2, I3 + I4)		-	
	counting frequency	< 3 kHz		-	
	pulse shape	square-wave		-	
	signal offset	90°		-	
		pulse / pause ratio	1:1		-
Rapid counter inputs	number	4 (I1, I2, I3, I4)		-	
	counting frequency	< 3 kHz		-	
	pulse shape	square-wave		-	
	pulse / pause ratio	1:1		-	
Cable length (shielded)		< 20 m		-	
Input circuit - Analog inputs					
Number		4 (I7, I8, I11, I12)		-	
Electrical isolation	to voltage supply	no		-	
	to digital inputs	no		-	
	to outputs	yes		-	
	to PC interface, memory modul, CL-NET, CL-LINK	yes		-	
Input type		DC voltage		-	
Signal range		0-10 V DC		-	
Resolution	analog	0.01 V		-	
	digital	0.01 V; 10 Bit (value 0-1023)		-	
Input impedance		11.2 k Ω		-	
Accuracy of the actual value	two CL-LD... devices	$\pm 3\%$		-	
	within one device	$\pm 2\%$		-	
Conversion time analog/digital		each cycle		-	
Input current		< 1 mA		-	
Cable length (shielded)		< 30 m		-	

Logic relays

Technical data

Data at $T_a = 25\text{ °C}$ and rated values, if nothing else indicated.

Type		CL-LD...16DC2	CL-LD...17DC2	CL-LDR.16AC2
Output circuit - Analog outputs				
Number		-	1	-
Electrical separation	from voltage supply	-	no	-
	from the digital inputs	-	no	-
	from the digital outputs	-	yes	-
	from PC interface, memory module, CL-NET, CL-LINK	-	yes	-
Output type		-	DC voltage	-
Signal range		-	0-10 V DC	-
Max. output current		-	0.01 A	-
Burden resistance		-	1 k Ω	-
Overload and short-circuit protection		-	yes	-
Resolution	analog	-	0.01 V DC	-
	digital	-	10 Bit, (value: 0-1023)	-
Setting time		-	100 ms	-
Accuracy	-25...+55 °C	-	2 %	-
	25 °C	-	1 %	-
Conversion time		-	each CPU cycle	-
General data				
Dimensions (W x H x D)		CL-LDR: 89 x 90 x 44 mm (3.5 x 3.54 x 1.73 inch)		89 x 90 x 44 mm
		CL-LDT (build-in): 89 x 90 x 25 mm (3.5 x 3.54 x 0.98 inch)		(3.5 x 3.54 x 1.73 inch)
Weight		CL-LDR: 0.15 kg (0.33 lb) / CL-LDT: 0.14 kg (0.31 lb)		0.15 kg (0.33 lb)
Mounting		snap-on power supply unit		
Mounting position		horizontal / vertical		
Electrical connection				
Wire size	fine-strand with wire end ferrule	0.2 mm ² / 2.5 mm ² (24-12 AWG)		
	rigid	0.2 mm ² / 4 mm ² (24-12 AWG)		
Electrical connection - Data cable				
Wire size	fine-strand with wire end ferrule	0.08 mm ² / 1.5 mm ² (28-12 AWG)		
	rigid	0.08 mm ² / 2.5 mm ² (28-12 AWG)		
Environmental data				
Ambient temperature range	operation	-25...+55 °C (cold acc. to IEC 60068-2-1, heat acc. to IEC 60068-2-2)		
	storage	-40...+70 °C		
Condensation		avoid condensation with suitable methods		
Humidity, no condensation (IEC/EN 60068-2-30)		5-95 %		
Atmospheric pressure (operation)		795-1080 hPa		
Degree of protection (IEC/EN 60529)		IP20		
Vibration (IEC/EN 60068-2-6)		10-57 Hz (constant amplitude 0.15 mm), 57-150 Hz (constant acceleration 2 g)		
Shock (half-sine 15 g / 11 ms) (IEC/EN 60068-2-27)		18 Shocks		
Drop (IEC/EN 60068-2-31) height of fall		50 mm		
Free fall, packaged (IEC/EN 60068-2-32)		1 m		
Insulation data				
Pollution degree		2		
Rating of air and creepage distances		EN 50178, UL 508, CSA C22.2, No. 142		
Isolation resistance		EN 50178		
Standards				
Standards and directives		EN 61000-6-1/-2/-3/-4, IEC/EN 61000-4, IEC 60068-2-6, IEC 60068-2-27		
Electromagnetic compatibility				
electrostatic discharge (ESD)	IEC/EN 61000-4-2	Level 3 (air discharge 8 kV, contact discharge 6 kV)		
electromag. field (HF radiation res.)	IEC/EN 61000-4-3	10 V/m		
fast transients (Burst)	IEC/EN 61000-4-4	Level 3 (supply cable 2 kV, signal cable 2 kV)		
powerful impulses (Surge)	IEC/EN 61000-4-5	2 kV (supply cable symmetrical), Level 2 (0.5 kV supply cable symmetrical)		
HF line emission	IEC/EN 61000-4-6	10 V		
Interference suppression (EN 55011, EN 55022)		class B		

Logic relays

Technical data

Data at $T_a = 25\text{ °C}$ and rated values, if nothing else indicated.

Type		CL-LDR...
Output circuit - Relay outputs		
Number		4
Outputs in groups of		-
Parallel switching of outputs to increase capacity		not permissible
Fusing of the output relay		circuit-breaker B16 or fuse 8 A (slow-acting)
Electrical isolation	from voltage supply	yes
	from the inputs	yes
	from PC interface, memory module, CL-NET, CL-LINK	yes
	protective separation	300 V AC
	Basic isolation	600 V AC
Mechanical lifetime		10×10^6 switching cycles
Rung	conventional thermal current (10 A UL)	8 A
	recommended load 12 V AC/DC	> 500 mA
	short-circuit proof $\cos \varphi = 1$; characteristic B16 at 600 A	16 A
	short-circuit proof $\cos \varphi = 0.5$ up to 0.7; characteristic B16 at 900 A	16 A
	Rated impulse withstand voltage U_{imp} contact-coil	6 kV
	Rated operational voltage U_{op}	250 V AC
Rated insulation voltage U_i		250 V AC
Protective separation (EN 50178)	between coil and contact	300 V AC
	between two contacts	300V AC
Making capacity	AC15, 250 V AC, 3 A (600 ops./h)	300.000 switching cycles
	DC13, L/R \leq 150 ms, 24 V DC, 1 A (500 ops./h)	200.000 switching cycles
Breaking capacity	AC15, 250 V AC, 3 A (600 ops./h)	300.000 switching cycles
	DC13, L/R \leq 150 ms, 24 V DC, 1 A (500 ops/h)	200.000 switching cycles
Incandescent lamp load	1000 W at 230/240 V AC	25.000 switching cycles
	500 W at 115/120 V AC	25.000 switching cycles
Fluorescent lamp load	10 x 58 W at 230/240 V AC with electrical control gear	25.000 switching cycles
	10 x 58 W at 230/240 V AC uncompensated	25.000 switching cycles
	1 x 58 W at 230/240 V AC conventional compensated	25.000 switching cycles
Switching frequency	mechanical operations	10×10^6
	switching frequency	10 Hz
	resistive load / lamp load	2 Hz
	inductive load	0.5 Hz
UL/CSA		
Continuous current at 240 V		10 A AC
Continuous current at 24 V		8 A DC
AC	Utilization category (Control Circuit Rating Codes)	B 300 Light Pilot Duty
	max. rated operational voltage	300 V AC
	max. continuous thermal current $\cos \varphi = 1$ at B 300	5 A
	max. making / breaking apparent power (Make/Break) $\cos \varphi \neq 1$ at B 300	3600/360 VA
DC	Utilization category (Control Circuit Rating Codes)	R 300 Light Pilot Duty
	max. rated operational voltage	300 V DC
	max. continuous thermal current at R 300	1 A
	max. making / breaking apparent power (Make/Break) at R 300	28/28 VA

Logic relays

Technical data

Data at $T_a = 25\text{ }^\circ\text{C}$ and rated values, if nothing else indicated.

Type	CL-LDT...
Output circuit - Transistor outputs	
Number	4
Rated operational voltage U_o	24 V DC
Operational voltage range	20.4-28.8 V DC
Residual ripple	-
Supply current	on „0“ signal typ. 18 mA / max. 32 mA on „1“ signal typ. 24 mA / max. 44 mA
Reverse voltage protection	yes (Attention: If supply voltage is reversed, applying voltage at the outputs, causes a short circuit.)
Electrical isolation	from voltage supply yes from the inputs yes from PC interface, memory module, CL-NET, CL-LINK yes
Rated operational current I_o on „1“ signal DC	max. 0.5 A
Lamp load without R_f	5 W (Q1-Q4)
Residual current on „0“ signal per channel	< 0.1 mA
Max. output voltage	on „0“ signal at external load < 10 M Ω 2.5 V on „1“ signal at $I_o = 0.5\text{ A}$ $U = U_o - 1\text{ V}$
Short-circuit protection	thermal (Q1-Q4), (analysis results from diagnosis input I16)
Short-circuit tripping current for $R_s \leq 10\text{ m}\Omega$	$0.7\text{ A} \leq I_s \leq 2\text{ A}$ per output
Total short-circuit current	8 A
Peak short-circuit current	16 A
Thermal tripping	yes
Max. switching frequency with constant resistive load $R_L < 100\text{ k}\Omega$ (depending on active channels and their load)	40.000 switching cycles/h
Parallel connection of outputs	with resistive load, inductive load with external suppressor, combination within one group group 1: Q1-Q4 number of outputs max. 4 max. total current 2 A (Attention! Outputs must be actuated simultaneously and for the same length of time.)
Indication of operational states of the outputs	LCD-Display (if existing)
Inductive load ¹⁾ without external suppressor	
$T_{0.95} = 1\text{ ms}$, $R = 48\ \Omega$, $L = 16\text{ mH}$	utilization factor 0.25 g duty time 100 % max. switching frequency $f = 0.5\text{ Hz}$ (max. duty time = 50 %) 1500 switching cycles
DC13, $T_{0.95} = 72\text{ ms}$, $R = 48\ \Omega$, $L = 1.15\text{ H}$	utilization factor 0.25 g duty time 100 % max. switching frequency $f = 0.5\text{ Hz}$ (max. duty time = 50 %) 1500 switching cycles
$T_{0.95} = 15\text{ ms}$, $R = 48\ \Omega$, $L = 0.24\text{ H}$	utilization factor 0.25 g duty time 100 % max. switching frequency $f = 0.5\text{ Hz}$ (max. duty time = 50 %) 1500 switching cycles
Inductive load ¹⁾ with external suppressor	
	demand factor 1 g duty time 100 % max. switching frequency max. duty time depends on suppressor

¹⁾ For inductive loading, without external suppression of the transistor outputs, the following applies:
 $T_{0.95}$ = time in ms, until 95 % of the steady-state current is achieved. $T_{0.95} \times 3 \times T_{0.65} = 3 \times L/R$.

Data transfer rate in the CL-NET network: bus lengths of 40 m and over only attainable with cables with additional cross-section and connection adapter.

Logic relays

Dimensional drawings

Dimensional drawings

dimensions in mm

CL-LSR, CL-LST

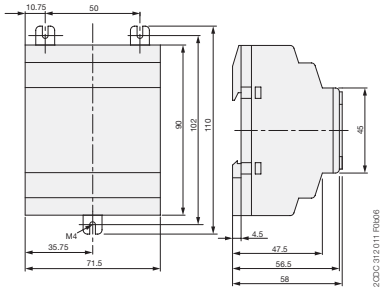

CL-LMR, CL-LMT

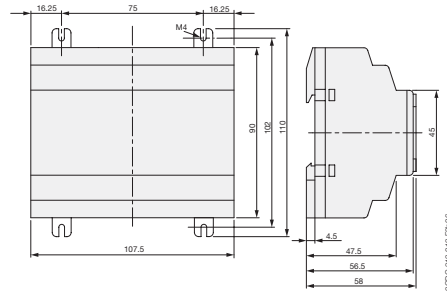

CL-LER.20

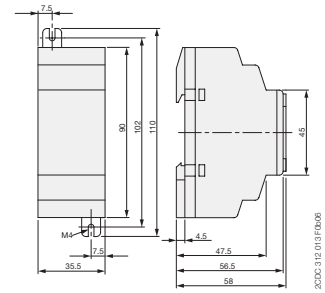

CL-LDD

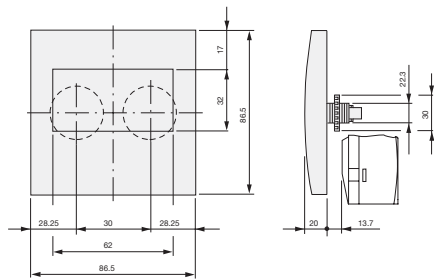

CL-LDD.K + CL-LDC.L.. +
(CL-LDR or CL-LDT)

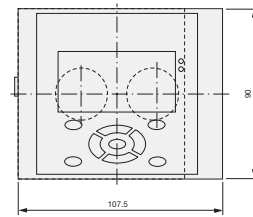

CL-LDC.S..

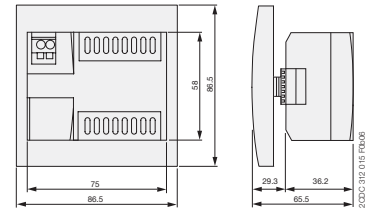

CL-LDR, CL-LDT

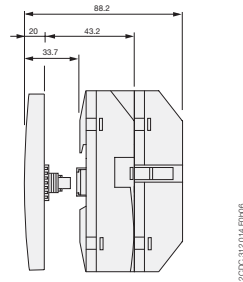
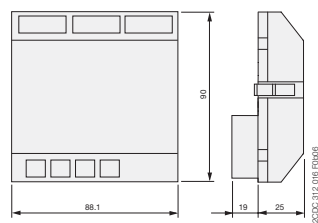

Index

Alphanumerical

Type	Page	Type	Page	Type	Page	Type	Page
Numbers		BNMS F125mA-3	5/73	CC-E IAC/ILPO	4/11	CL-LDD.XK	7/6, 9
20-100W-MC	6/4	BNMS F125mA-4	5/73	CC-E IAC/V	4/11	CL-LDR.16AC2	7/9
20W-230V-HE	6/4	BNMS F500mA-1	5/73	CC-E IDC/I	4/11	CL-LDR.16DC2	7/9
40W-110V-HP	6/4	BNMS N5V-1.....	5/73	CC-E IDC/V	4/11	CL-LDR.17DC2	7/9
40W-230V-HE	6/4	BNMS N5V-2.....	5/73	CC-E I/I	4/8	CL-LDT.16DC2	7/9
40W-230V-HP	6/4	BNMS N5V-3.....	5/73	CC-E I/I-1	4/8	CL-LDT.17DC2	7/9
40W-230V-HP-E.....	6/4	BNMS N24V-1.....	5/73	CC-E I/I-2	4/8	CL-LEC.CI000	7/7
100W-110V-HP	6/4	BNMS N24V-2.....	5/73	CC-E I/V	4/8	CL-LER.20	7/7
100W-230V-HE	6/4	BNMS N24V-3.....	5/73	CC-E/RTD	4/9	CL-LER.18AC2	7/7
100W-230V-HP	6/4	BNMS N48V-3.....	5/73	CC-E RTD/I	4/9	CL-LER.18DC2	7/7
100W-230V-HP-ADJ.....	6/4	BNMS P5V-1	5/73	CC-E RTD/V	4/9	CL-LET.20DC2	7/7
100W-230V-HP-E.....	6/4	BNMS P5V-2.....	5/73	CC-E/STD	4/8	CL-LMR.C18AC1	7/7
200-300W-MC	6/4	BNMS P5V-3.....	5/73	CC-E/TC	4/10	CL-LMR.C18AC2	7/7
200W-230V-HE	6/4	BNMS P24V-1.....	5/73	CC-E TC/I	4/10	CL-LMR.C18DC1	7/7
250W-110V-HP	6/4	BNMS P24V-2.....	5/73	CC-E TC/V	4/10	CL-LMR.C18DC2	7/7
250W-230V-HP	6/4	BNMS P24V-3.....	5/73	CC-E V/I	4/8	CL-LMR.CX18AC1	7/7
250W-230V-HP-ADJ.....	6/4	BNMS P48V-3.....	5/73	CC-E V/V	4/8	CL-LMR.CX18AC2	7/7
300W-230V-HE	6/4	BNMS R24V-1.....	5/30, 73	CC-U/I	4/21	CL-LMR.CX18DC1	7/7
		BNMS R24V-2.....	5/30, 73	CC-U/RTD	4/21	CL-LMR.CX18DC2	7/7
		BNMS ST1	5/73	CC-U/RTDR	4/21	CL-LMT.C20DC2	7/7
A		BNMS ST2.....	5/73	CC-U/STD	4/21	CL-LMT.CX20DC2	7/7
AD 2,5	5/79z	BNMS T5V-1	5/73	CC-U/STDR	4/21	CL-LSR.12AC2	7/6
ADP.01	4/22	BNMS T24V-1	5/73	CC-U/TC	4/21	CL-LSR.12DC2	7/6
ADP.01	2/151	BNMS T24V-2	5/73	CC-U/TCR	4/21	CL-LSR.C12AC1	7/6
ADP.02	2/151	BNMS T48V-1	5/73	CC-U/V	4/21	CL-LSR.C12AC2	7/6
		BNMS T115V-1	5/73	CL-LAD.FD001	7/9	CL-LSR.C12DC1	7/6
B		BNMS T125V-1	5/73	CL-LAD.FD002	7/9	CL-LSR.C12DC2	7/6
BADH	5/30, 78	BNMS T230V-1	5/73	CL-LAD.FD011	7/9	CL-LSR.CX12AC1	7/6
BADH V0.....	5/54			CL-LAD.MD004	7/9	CL-LSR.CX12AC2	7/6
BADL.....	5/78	C		CL-LAD.TK001	7/9	CL-LSR.CX12DC1	7/6
BADL V0.....	5/54	C011-3-150	2/97	CL-LAD.TK002	7/9	CL-LSR.CX12DC2	7/6
BAM2	5/78	C011-70	2/97	CL-LAD.TK003	7/9	CL-LST.C12DC2	7/6
BAM2 V0.....	5/54, 78	C011-80	2/97	CL-LAD.TK004	7/9	CL-LST.CX12DC2	7/6
BAMH.....	5/78	C011-90	2/97	CL-LAD.TK005	7/9	CP-D 24/0.42	7/8
BAMH V0	5/78	C011-100	2/97	CL-LAD.TK006	7/9	CP-D 24/0.421)	7/8
BJ 612-10.....	5/54	C011-110	2/97	CL-LAD.TK007	7/8	CP-D 24/1.3	7/8
BJ612-10.....	5/78	C011-120	2/97	CL-LAD.TK009	7/9	CP-D 24/1.32)	7/8
BJ 612-70.....	5/54	C011-130	2/97	CL-LAD.TK011	7/9	COV.01	4/22
BJ612-70.....	5/78	C011-140	2/97	CL-LAS.FD001	7/8	COV.01	2/151
BJS9.....	5/79	C011-150	2/97	CL-LAS.MD003	7/8	COV.02	2/151
BNMS A24V-4	5/73	C011-160	2/97	CL-LAS.PS002	7/8	COV.11	2/151
BNMS CA I/U-250	5/77	C011-170	2/97	CL-LAS.TK001	7/8	COV.12	2/151
BNMS CAI/U-250	5/73	C512-24	2/106	CL-LAS.TK002	7/8	CM-AH-3	2/118
BNMS CAI/U-500	5/73	C512-D	2/106	CL-LAS.TK011	7/8	CM-CT 50/1	2/152
BNMS F2A-1.....	5/73	C512-E	2/106	CL-LDC.LAC2	7/9	CM-CT 50/5	2/152
BNMS F2A-2.....	5/73	C512-W	2/106	CL-LDC.LDC2	7/9	CM-CT 75/1	2/152
BNMS F2A-7.....	5/73	C513-D	2/106	CL-LDC.LNAC2	7/9	CM-CT 75/5	2/152
BNMS F5A-1	5/73	C513-E	2/106	CL-LDC.LNDC2	7/9	CM-CT 100/1	2/152
BNMS F5A-2.....	5/73	C513-W	2/106	CL-LDC.SAC2	7/6	CM-CT 100/5	2/152
BNMS F125mA-1	5/73	CC-E/I	4/11	CL-LDC.SDC2	7/6	CM-CT 150/1	2/152
BNMS F125mA-2	5/73	CC-E IAC/I	4/11	CL-LDD.K	7/6, 9	CM-CT 150/5	2/152

Index

Alphanumerical

Type	Page	Type	Page	Type	Page	Type	Page
CM-CT 200/1	2/152	CM-MPS.21S	2/34	CM-SRS.M1S	2/15	CP-T 24/10.0	3/34
CM-CT 200/5	2/152	CM-MPS.23P	2/34	CM-SRS.M2S	2/15	CP-T 24/20.0	3/34
CM-CT 300/1	2/152	CM-MPS.23S	2/34	CM-TCS.11P	2/106	CP-T 24/40.0	3/34
CM-CT 300/5	2/152	CM-MPS.31P	2/34	CM-TCS.11S	2/106	CR-M2LC	5/10
CM-CT 400/1	2/152	CM-MPS.31S	2/34	CM-TCS.12P	2/106	CR-M2LS	5/10
CM-CT 400/5	2/152	CM-MPS.41P	2/34	CM-TCS.12S	2/106	CR-M2SF	5/10
CM-CT 500/1	2/152	CM-MPS.41S	2/34	CM-TCS.13P	2/106	CR-M2SS	5/10
CM-CT 500/5	2/152	CM-MPS.43P	2/34	CM-TCS.13S	2/106	CR-M3LS	5/10
CM-CT 600/1	2/152	CM-MPS.43S	2/34	CM-TCS.21P	2/106	CR-M3SS	5/10
CM-CT 600/5	2/152	CM-MSE	2/96	CM-TCS.21S	2/106	CR-M4LC	5/10
CM-CT A	2/152	CM-MSN	2/96	CM-TCS.22P	2/106	CR-M4LS	5/10
CM-EFS.2P	2/16	CM-MSS (1)	2/96	CM-TCS.22S	2/106	CR-M4SF	5/10
CM-EFS.2S	2/16	CM-MSS (2)	2/96	CM-TCS.23P	2/106	CR-M4SS	5/10
CM-ENE MAX	2/117	CM-MSS (3)	2/96	CM-TCS.23S	2/106	CR-M012DC2	5/8
CM-ENE MIN	2/117	CM-MSS (4)	2/96	CM-UFD.M21	2/55	CR-M012DC2L	5/9
CM-ENN	2/117	CM-MSS (5)	2/96	CM-UFD.M22	2/55	CR-M012DC3	5/8
CM-ENS	2/117	CM-MSS (6)	2/96	CM-UFS.1	2/55	CR-M012DC3L	5/9
CM-ESS.1P	2/16	CM-MSS (7)	2/96	CM-WDS	2/142	CR-M012DC4	5/8
CM-ESS.1S	2/16	CM-PAS.31P	2/33	CP-A CM	3/51	CR-M012DC4L	5/9
CM-ESS.2P	2/16	CM-PAS.31S	2/33	CP-A RU	3/51	CR-M012DC4LDG	5/10
CM-ESS.2S	2/16	CM-PAS.41P	2/33	CP-ASI/2.8	3/60	CR-M012DC4LG	5/10
CM-ESS.MP	2/16	CM-PAS.41S	2/33	CP-ASI/4.0	3/60	CR-M024AC2	5/8
CM-ESS.MS	2/16	CM-PBE	2/33	CP-ASI/4.0 DC/DC	3/60	CR-M024AC2L	5/9
CM-GM-1	2/118	CM-PFE	2/33	CP-ASI/8.0	3/60	CR-M024AC3	5/8
CM-HE	2/118	CM-PFS.P	2/33	CP-B 24/3.0	3/68	CR-M024AC3L	5/9
CM-IVN.P	2/72	CM-PFS.S	2/33	CP-B 24/10.0	3/68	CR-M024AC4	5/8
CM-IVN.S	2/72	CM-PSS.31P	2/33	CP-B 24/20.0	3/68	CR-M024AC4G	5/9
CM-IWN.1P	2/72	CM-PSS.31S	2/33	CP-B EXT.2	3/68	CR-M024AC4L	5/9
CM-IWN.1S	2/72	CM-PSS.41P	2/33	CP-D 12/0.83	3/10	CR-M024AC4LG	5/10
CM-IWN.4P	2/72	CM-PSS.41S	2/33	CP-D 12/2.1	3/10	CR-M024DC2	5/8
CM-IWN.4S	2/72	CM-PVE	2/33	CP-D 24/0.42	3/10	CR-M024DC2L	5/9
CM-IWN.5P	2/72	CM-PVS.31P	2/33	CP-D 24/1.3	3/10	CR-M024DC3	5/8
CM-IWN.5S	2/72	CM-PVS.31S	2/33	CP-D 24/2.5	3/10	CR-M024DC3L	5/9
CM-IWN.6P	2/72	CM-PVS.41P	2/33	CP-D 24/4.2	3/10	CR-M024DC4	5/8
CM-IWN.6S	2/72	CM-PVS.41S	2/33	CP-D RU	3/51	CR-M024DC4G	5/9
CM-IWS.1P	2/72	CM-PVS.81P	2/33	CP-E 5/3.0	3/20	CR-M024DC4L	5/9
CM-IWS.1S	2/72	CM-PVS.81S	2/33	CP-E 12/2.5	3/20	CR-M024DC4LD	5/9
CM-IWS.2P	2/72	CM-SE-300	2/118	CP-E 12/10.0	3/20	CR-M024DC4LDG	5/10
CM-IWS.2S	2/72	CM-SE-600	2/118	CP-E 24/0.75	3/20	CR-M024DC4LG	5/10
CM-KH-3	2/118	CM-SE-1000	2/118	CP-E 24/1.25	3/20	CR-M048AC2	5/8
CM-KRN	2/130	CM-SFS.21P	2/15	CP-E 24/2.5	3/20	CR-M048AC2L	5/9
CM-LWN	2/82	CM-SFS.21S	2/15	CP-E 24/5.0	3/20	CR-M048AC3	5/8
CM-MPN.52P	2/34	CM-SFS.22S	2/15	CP-E 24/10.0	3/20	CR-M048AC3L	5/9
CM-MPN.52S	2/34	CM-SIS	2/136	CP-E 24/20.0	3/20	CR-M048AC4	5/8
CM-MPN.62P	2/34	CM-SRS.11P	2/15	CP-E 48/0.62	3/20	CR-M048AC4L	5/9
CM-MPN.62S	2/34	CM-SRS.11S	2/15	CP-E 48/1.25	3/20	CR-M048AC4LG	5/10
CM-MPN.72P	2/34	CM-SRS.12S	2/15	CP-E 48/5.0	3/20, 34	CR-M048DC2	5/8
CM-MPN.72S	2/34	CM-SRS.21P	2/15	CP-E 48/10.0	3/20, 34	CR-M048DC2L	5/9
CM-MPS.11P	2/34	CM-SRS.21S	2/15	CP-E 48/20.0	3/34	CR-M048DC3	5/8
CM-MPS.11S	2/34	CM-SRS.22S	2/15	CP-RUD	3/51	CR-M048DC3L	5/9
CM-MPS.21P	2/34	CM-SRS.M1P	2/15	CP-T 24/5.0	3/34	CR-M048DC4	5/8

Index

Alphanumerical

Type	Page	Type	Page	Type	Page	Type	Page
CR-M048DC4L.....	5/9	CR-M230AC4G.....	5/9	CR-P/M 62V.....	5/11	CR-U 61EV.....	5/13
CR-M048DC4LG.....	5/10	CR-M230AC4L.....	5/9	CR-P/M 72.....	5/11	CR-U 61V.....	5/13
CR-M060AC3.....	5/8	CR-M230AC4LG.....	5/10	CR-P/M 72A.....	5/11	CR-U 71.....	5/13
CR-M060DC2.....	5/8	CR-MH.....	5/10	CR-P/M 82.....	5/11	CR-U 71A.....	5/13
CR-M060DC2L.....	5/9	CR-MH1.....	5/10	CR-P/M 92.....	5/11	CR-U 81.....	5/13
CR-M060DC3.....	5/8	CR-MJ.....	5/10	CR-P/M 92C.....	5/11	CR-U 91.....	5/13
CR-M060DC3L.....	5/9	CR-MM.....	5/10	CR-P/M 92CV.....	5/11	CR-U 91C.....	5/13
CR-M060DC4.....	5/8	CR-P012DC1.....	5/7	CR-P/M 92V.....	5/11	CR-U 91CV.....	5/13
CR-M060DC4L.....	5/9	CR-P012DC2.....	5/7	CR-PSS.....	5/7	CR-U 91V.....	5/13
CR-M060DC4LG.....	5/10	CR-P024AC1.....	5/7	CR-U2S.....	5/12	CR-U110AC2.....	5/12
CR-M110AC2.....	5/8	CR-P024AC2.....	5/7	CR-U2SM.....	5/12	CR-U110AC2L.....	5/12
CR-M110AC2L.....	5/9	CR-P024AC2G.....	5/7	CR-U3E.....	5/12	CR-U110AC3.....	5/12
CR-M110AC3.....	5/8	CR-P024DC1.....	5/7	CR-U3S.....	5/12	CR-U110AC3L.....	5/12
CR-M110AC3L.....	5/9	CR-P024DC2.....	5/7	CR-U3SM.....	5/12	CR-U110DC2.....	5/12
CR-M110AC4.....	5/8	CR-P048AC1.....	5/7	CR-U012DC2.....	5/12	CR-U110DC2L.....	5/12
CR-M110AC4G.....	5/9	CR-P048AC2.....	5/7	CR-U012DC2L.....	5/12	CR-U110DC3.....	5/12
CR-M110AC4L.....	5/9	CR-P048DC1.....	5/7	CR-U012DC3.....	5/12	CR-U110DC3L.....	5/12
CR-M110AC4LG.....	5/10	CR-P048DC2.....	5/7	CR-U012DC3L.....	5/12	CR-U120AC2.....	5/12
CR-M110DC2.....	5/8	CR-P110AC1.....	5/7	CR-U 21.....	5/13	CR-U120AC2L.....	5/12
CR-M110DC2L.....	5/9	CR-P110AC2.....	5/7	CR-U024AC2.....	5/12	CR-U120AC3.....	5/12
CR-M110DC3.....	5/8	CR-P110AC2G.....	5/7	CR-U024AC2L.....	5/12	CR-U120AC3L.....	5/12
CR-M110DC3L.....	5/9	CR-P110DC1.....	5/7	CR-U024AC3.....	5/12	CR-U125DC3.....	5/12
CR-M110DC4.....	5/8	CR-P110DC2.....	5/7	CR-U024AC3L.....	5/12	CR-U220DC2.....	5/12
CR-M110DC4L.....	5/9	CR-P120AC1.....	5/7	CR-U024DC2.....	5/12	CR-U220DC2L.....	5/12
CR-M110DC4LG.....	5/10	CR-P120AC2.....	5/7	CR-U024DC2L.....	5/12	CR-U220DC3.....	5/12
CR-M120AC2.....	5/8	CR-P230AC1.....	5/7	CR-U024DC3.....	5/12	CR-U220DC3L.....	5/12
CR-M120AC2L.....	5/9	CR-P230AC2.....	5/7	CR-U024DC3L.....	5/12	CR-U230AC2.....	5/12
CR-M120AC3.....	5/8	CR-P230AC2G.....	5/7	CR-U 41.....	5/13	CR-U230AC2L.....	5/12
CR-M120AC3L.....	5/9	CR-PH.....	5/7	CR-U 41B.....	5/13	CR-U230AC3.....	5/12
CR-M120AC4.....	5/8	CR-PJ.....	5/7	CR-U 41BV.....	5/13	CR-U230AC3L.....	5/12
CR-M120AC4L.....	5/9	CR-PLC.....	5/7	CR-U 41C.....	5/13	CR-UH.....	5/12
CR-M120AC4LG.....	5/10	CR-PLS.....	5/7	CR-U 41CV.....	5/13	CR-U T.....	5/13
CR-M125DC2.....	5/8	CR-PLSx.....	5/7	CR-U 41V.....	5/13		
CR-M125DC2L.....	5/9	CR-PM.....	5/7	CR-U048AC2.....	5/12	D	
CR-M125DC3.....	5/8	CR-P/M 22.....	5/11	CR-U048AC2L.....	5/12	D 2,5/5-MP.....	5/30, 73
CR-M125DC3L.....	5/9	CR-P/M 42.....	5/11	CR-U048AC3.....	5/12	D 2,5/5-MP1.....	5/73
CR-M125DC4.....	5/8	CR-P/M 42B.....	5/11	CR-U048AC3L.....	5/12	D 2,5/5-MP-24VAC/DC.....	5/30, 73
CR-M125DC4L.....	5/9	CR-P/M 42BV.....	5/11	CR-U048DC2.....	5/12	D 2,5/5-MP-24VDC.....	5/30, 73
CR-M125DC4LG.....	5/10	CR-P/M 42C.....	5/11	CR-U048DC2L.....	5/12	D 2,5/5-MP-48VAC/DC.....	5/30, 73
CR-M220DC2.....	5/8	CR-P/M 42CV.....	5/11	CR-U048DC3.....	5/12	D 2,5/5-MP-110VAC.....	5/30, 73
CR-M220DC2L.....	5/9	CR-P/M 42V.....	5/11	CR-U048DC3L.....	5/12	D 2,5/5-MP-230VAC.....	5/30, 73
CR-M220DC3.....	5/8	CR-P/M 52B.....	5/11	CR-U 51B.....	5/13	D 2,5/5-OBIA-0030-24VAC.....	5/36
CR-M220DC3L.....	5/9	CR-P/M 52C.....	5/11	CR-U 51C.....	5/13	D 2,5/5-OBIA-0030-48VAC.....	5/36
CR-M220DC4.....	5/8	CR-P/M 52D.....	5/11	CR-U 51D.....	5/13	D 2,5/5-OBIA-0030-115VAC.....	5/36
CR-M220DC4L.....	5/9	CR-P/M 62.....	5/11	CR-U060AC3.....	5/12	D 2,5/5-OBIA-0030-230VAC.....	5/36
CR-M220DC4LG.....	5/10	CR-P/M 62C.....	5/11	CR-U 61.....	5/13	D 2,5/5-OBIC-0030-5VDC.....	5/36
CR-M230AC2.....	5/8	CR-P/M 62CV.....	5/11	CR-U 61C.....	5/13	D 2,5/5-OBIC-0030-24VDC.....	5/36
CR-M230AC2L.....	5/9	CR-P/M 62D.....	5/11	CR-U 61CV.....	5/13	D 2,5/5-OBIC-0030-48VDC.....	5/36
CR-M230AC3.....	5/8	CR-P/M 62DV.....	5/11	CR-U 61D.....	5/13	D 2,5/5-OBIC-0030-125VDC.....	5/36
CR-M230AC3L.....	5/9	CR-P/M 62E.....	5/11	CR-U 61DV.....	5/13	D 2,5/5-OBOA-1000-24VAC.....	5/36
CR-M230AC4.....	5/8	CR-P/M 62EV.....	5/11	CR-U 61E.....	5/13	D 2,5/5-OBOA-1000-24VAC/DC.....	5/36

Index

Alphanumerical

Type	Page	Type	Page	Type	Page	Type	Page
D 2,5/5-OBOA-1000-48VAC/DC	5/36	I		OBIC 0100-48-60VAC/DC	5/67	RB 111 A-230VAC/DC	5/53
D 2,5/5-OBOA-1000-110VAC	5/36	IDC jumper	5/79	OBIC 0100-115-230VAC/DC	5/67	RB 111 AI-24VAC/DC	5/53
D 2,5/5-OBOA-1000-230VAC	5/36	ILPH BdC /RS 422 - 485	4/37	OBOA 1000-24VDC	5/67	RB 111 AR-24VAC/DC	5/53
D 2,5/5-OBOC-0100-5VAC	5/36	ILPH RS 232 /	4/37	OBOA 1000-48-60VAC/DC	5/67	RB 121-5VDC	5/53
D 2,5/5-OBOC-0100-24VAC	5/36	ILPH RS 232 BdC	4/37	OBOA 1000-115VAC/DC	5/67	RB 121-12VDC	5/53
D 2,5/5-OBOC-0100-48VAC	5/36	ILPH RS 232 / FO-P (24...42 V AC/ DC power supply)	4/37	OBOA 1000-230VAC/DC	5/67	RB 121-24VDC	5/53
D 2,5/5-OBOC-1000-5VDC	5/36	ILPH RS 232 / FO-P (110...240 V AC/ DC power supply)	4/37	OBOA 2000-24VDC	5/67	RB 121 A-24VAC/DC	5/53
D 2,5/5-OBOC-1000-24VAC/DC	5/36	ILPH RS 232 / FO-S (24...42 V AC/ DC power supply)	4/37	OBOC 1000-5-12VDC	5/67	RB 121 A-48-60VAC/DC	5/53
D 2,5/5-OBOC-1000-48VAC/DC	5/36	ILPH RS 232 / FO-S (110...240 V AC/ DC power supply)	4/37	OBOC 1000-24VDC	5/67	RB 121 A 60-230VAC/DC	5/54
D 2,5/5-OBOC-1000-110VAC	5/36	ILPH RS 232 / RS 232 (24-48 V DC power supply)	4/37	OBOC 1000-48-60VAC/DC	5/67	RB 121 A-115VAC/DC	5/53
D 2,5/5-OBOC-1000-230VAC	5/36	ILPH RS 232 / RS 232 (115-230 V DC power supply)	4/37	OBOC 1000-115VAC/DC	5/67	RB 121 A-230VAC/DC	5/53
D 2,5/5-OBOC-2000-5VDC	5/36	ILPH RS 232 / RS 422-485 (24-48 V DC	4/37	OBOC 1000-230VAC/DC	5/67	RB 121 AI-24VAC/DC	5/54
D 2,5/5-OBOC-2000-24VAC/DC	5/36	ILPH RS 232 / RS 422-485 (115-230 V DC	4/37	OBOC 1500-24VAC/DC	5/67	RB 121 AR-115VAC/DC	5/54
D 2,5/5-OBOC-2000-24VDC	5/36	ILPH RS 232-RS 485 / Ethernet	4/37	OBOC 5000-24VDC	5/67	RB 121 AR-230VAC/DC	5/54
D 2,5/5-OBOC-2000-48VAC/DC	5/36	ILPH RS 422 - 485 / RS 422 - 485 (24 V DC power supply)	4/37	OBOC 5000-115VAC/DC	5/67	RB 122 A-24VAC/DC	5/54
D 2,5/5-OBOC-2000-110VAC	5/36	ILPH RS 485 / FO-P (24...42 V AC/ DC power supply)	4/37	OBRIC 0100-5-12VDC	5/67	RB 122 A-48-60VAC/DC	5/54
D 2,5/5-OBOC-2000-230VAC	5/36	ILPH RS 485 / FO-P (110...240 V AC/ DC power supply)	4/37	OBRIC 0100-24VDC	5/67	RB 122 A-115VAC/DC	5/54
D 2,5/5-R121-24VDC	5/30	ILPH RS 485 / FO-S (24...42 V AC/ DC power supply)	4/37	OBRIC 0100-48-60VAC/DC	5/67	RB 122 A-230VAC/DC	5/54
D 2,5/5-R121AL-24VAC/DC	5/30	ILPH RS 485 / FO-S (110...240 V AC/ DC power supply)	4/37	OBRIC 0100-115-230VAC/DC	5/67	RBR 101 AR-24VAC/DC	5/53
D 2,5/5-R121AL-48VAC/DC	5/30	J		OBRIC 0100-115-230VAC/DC	5/67	RBR 111 A-24VAC/DC	5/53
D 2,5/5-R121BL-110VAC	5/30	Jumper bar	5/79	OBROA 1000-24VDC	5/67	RBR 111 A-48-60VAC/DC	5/53
D 2,5/5-R121BL-230VAC	5/30	M		OBROA 1000-48-60VAC/DC	5/67	RBR 111 A-115VAC/DC	5/53
D 2,5/5-R121L-24VDC	5/30	MAR.01	2/151	OBROA 1000-115VAC/DC	5/67	RBR 111 A-230VAC/DC	5/53
D4/12-3-3	5/54, 78	MAR.01	4/22	OBROA 1000-230VAC/DC	5/67	RBR 111 AI-24VAC/DC	5/53
D4/12-3R-3R	5/54, 78	MAR.02	2/151	OBROA 2000-24VDC	5/67	RBR 111 AR-24VAC/DC	5/53
DCB	5/30, 73, 79	MAR.12	2/151	OBROC 1000-5-12VDC	5/67	RBR 122 A-24VAC/DC	5/54
DX111 / DX122	2/88	Marking for Interface Modules	5/80	OBROC 1000-24VDC	5/67	RBR 122 A-48-60VAC/DC	5/54
E		Marking for terminal blocks	5/80	OBROC 1000-48-60VAC/DC	5/67	RBR 122 A-115VAC/DC	5/54
EIP	5/79	MOS output optocoupler plug	5/76	OBROC 1000-115VAC/DC	5/67	RBR 122 A-230VAC/DC	5/54
EV6D	5/79	MOS output optocoupler plugs	5/75	OBROC 1000-230VAC/DC	5/67	RC55	5/30, 80
EPD24-TB-101-0.5A	3/75	MTQ22-FBP	2/89	OBROC 1000-115VAC/DC	5/67	RC65	5/80
EPD24-TB-101-1A	3/75	O		OBROC 1500-24VAC/DC	5/67	RC65 / RC610	5/54
EPD24-TB-101-2A	3/75	OBIC 0100-5-12VDC	5/67	OBROC 5000-24VDC	5/67	RC610	5/80
EPD24-TB-101-3A	3/75	OBIC 0100-24VDC	5/67	OBROC 5000-115VAC/DC	5/67	RLV	5/79
EPD24-TB-101-4A	3/75			OBROC 5000-230VAC/DC	5/67	RPEV	5/79
EPD24-TB-101-6A	3/75	P				RS 422-485	4/37
EPD24-TB-101-8A	3/75	PC9	5/79			S	
EPD24-TB-101-10A	3/75	PCMS	5/79			SC 612	5/54
EPD24-TB-101-12A	3/75	PCMS V0	5/73			SC612	5/78
EPD-BB500	3/75	PEF	5/79			T	
EPD-SB21	3/75	PR3.G2	5/78			Terminal blocks	5/73
F		PR3.Z2	5/78			Thermostat	6/4
FC2	5/30, 54, 73, 78	PR4	5/78			Transistor output optocoupler plugs	5/75
		PR5	5/78			Triac output optocoupler plug	5/76
		PR30	5/78			U	
		R				UMC100-FBP	2/88
		RB 101 AR-24VAC/DC	5/53				
		RB 111 A-24VAC/DC	5/53				
		RB 111 A-48-60VAC/DC	5/53				
		RB 111 A-115VAC/DC	5/53				

Index Numerical

Order code	Type	Page	Order code	Type	Page	Order code	Type	Page
1SAR			1SNA607269R2600	D 2,5/5-OBOA-1000-230VAC....	5/36	1SNA645061R0600	OBOA 1000-48-60VAC/DC.....	5/67
1SAR700100R0005	C512-24.....	2/106	1SNA607270R2300	D 2,5/5-OB0C-1000-110VAC....	5/36	1SNA645062R0700	OBOA 1000-115VAC/DC.....	5/67
1SAR700100R0010	C512-W.....	2/106	1SNA607271R1000	D 2,5/5-OB0C-1000-230VAC....	5/36	1SNA645063R0000	RB 111 AI-24VAC/DC.....	5/53
1SAR700110R0010	C513-W.....	2/106	1SNA607272R1100	D 2,5/5-OB0C-2000-110VAC....	5/36	1SNA645064R0100	RB 121-24VDC.....	5/53
1SFA			1SNA607273R1200	D 2,5/5-OB0C-2000-230VAC....	5/36	1SNA645065R0200	RB 121-24VDC.....	5/53
1SFA611410R1506	MT-150B.....	1/39	1SNA607274R1300	D 2,5/5-OBIC-0030-5VDC.....	5/36	1SNA645069R0100	RB 121-12VDC.....	5/53
1SFA611410R2506	MT-250B.....	1/39	1SNA607275R1400	D 2,5/5-OBIC-0030-125VDC.....	5/36	1SNA645501R0500	RB 121 A-24VAC/DC.....	5/53
1SFA611410R3506	MT-350B.....	1/39	1SNA645001R0300	RB 121 A-24VAC/DC.....	5/53	1SNA645502R0600	RB 121 A-48-60VAC/DC.....	5/53
1SFA611940R1060	MA16-1060.....	1/39	1SNA645002R0400	RB 121 A-48-60VAC/DC.....	5/53	1SNA645503R0700	RB 121 A-115VAC/DC.....	5/53
1SFA616920R8029	KA1-8029.....	1/39	1SNA645003R0500	RB 121 A-115VAC/DC.....	5/53	1SNA645504R0000	RB 121 A-230VAC/DC.....	5/53
1SFA616920R8030	KA1-8030.....	1/39	1SNA645004R0400	RB 121 A-230VAC/DC.....	5/53	1SNA645505R0100	RB 121 A-24VAC/DC.....	5/53
1SNA			1SNA645005R0700	RB 121 A-24VAC/DC.....	5/53	1SNA645506R0200	RB 121 A-48-60VAC/DC.....	5/53
1SNA007865R2600	FC2.....	5/30	1SNA645006R0000	RB 121 A-48-60VAC/DC.....	5/53	1SNA645507R0300	RB 121 A-115VAC/DC.....	5/53
1SNA031820R1400	BNMS R24V-1.....	5/30	1SNA645007R0100	RB 121 A-115VAC/DC.....	5/53	1SNA645508R1400	RB 121 A-230VAC/DC.....	5/53
1SNA031847R1300	BNMS R24V-2.....	5/30	1SNA645008R1200	RB 121 A-230VAC/DC.....	5/53	1SNA645509R1500	RB 121 AI-24VAC/DC.....	5/54
1SNA105028R2100	DCB.....	5/30	1SNA645009R1300	RB 121 AI-24VAC/DC.....	5/54	1SNA645510R0100	RB 121 AI-24VAC/DC.....	5/54
1SNA607201R1300	D 2,5/5-R121L-24VDC.....	5/30	1SNA645010R0700	RB 121 AI-24VAC/DC.....	5/54	1SNA645511R2600	RB 121 AR-230VAC/DC.....	5/54
1SNA607203R1500	D 2,5/5-OB0C-0100-5VAC.....	5/36	1SNA645011R2400	RB 121 AR-230VAC/DC.....	5/54	1SNA645512R2700	RBR 122 A-24VAC/DC.....	5/54
1SNA607204R1600	D 2,5/5-OB0C-0100-24VDC.....	5/36	1SNA645012R2500	RB 122 A-24VAC/DC.....	5/54	1SNA645513R2000	RBR 122 A-230VAC/DC.....	5/54
1SNA607205R1700	D 2,5/5-OB0C-0100-48VAC.....	5/36	1SNA645013R2600	RB 122 A-230VAC/DC.....	5/54	1SNA645514R2100	RBR 111 A-24VAC/DC.....	5/53
1SNA607206R1000	D 2,5/5-OB0C-1000-5VDC.....	5/36	1SNA645014R2700	RB 111 A-24VAC/DC.....	5/53	1SNA645515R2200	RBR 111 A-48-60VAC/DC.....	5/53
1SNA607207R1100	D 2,5/5-OB0C-1000-24VDC.....	5/36	1SNA645015R2000	RB 111 A-48-60VAC/DC.....	5/53	1SNA645516R2300	RBR 111 A-115VAC/DC.....	5/53
1SNA607208R2200	D 2,5/5-OB0C-2000-5VDC.....	5/36	1SNA645016R2100	RB 111 A-115VAC/DC.....	5/53	1SNA645517R2400	RBR 111 A-230VAC/DC.....	5/53
1SNA607209R2300	D 2,5/5-OB0C-2000-24VDC.....	5/36	1SNA645017R2200	RB 111 A-230VAC/DC.....	5/53	1SNA645518R0500	RBR 111 AR-24VAC/DC.....	5/53
1SNA607210R1700	D 2,5/5-OBIC-0030-24VDC.....	5/36	1SNA645018R0300	RB 111 AR-24VAC/DC.....	5/53	1SNA645519R0600	RBR 101 AR-24VAC/DC.....	5/53
1SNA607211R0400	D 2,5/5-OBIC-0030-48VDC.....	5/36	1SNA645019R0400	RB 101 AR-24VAC/DC.....	5/53	1SNA645520R0300	RB 121 A 60-230VAC/DC.....	5/54
1SNA607212R0500	D 2,5/5-OBIA-0030-24VAC.....	5/36	1SNA645020R0100	RB 121 A 60-230VAC/DC.....	5/54	1SNA645521R2000	OBRIC 0100-24VDC.....	5/67
1SNA607213R0600	D 2,5/5-OBIA-0030-48VAC.....	5/36	1SNA645021R2600	OBIC 0100-24VDC.....	5/67	1SNA645522R2100	OBRIC 0100-115-230VAC/DC...	5/67
1SNA607214R0700	D 2,5/5-OBIA-0030-115VAC.....	5/36	1SNA645022R2700	OBIC 0100-115-230VAC/DC.....	5/67	1SNA645524R2300	OBROC 5000-24VDC.....	5/67
1SNA607215R0000	D 2,5/5-OBIA-0030-230VAC.....	5/36	1SNA645024R2100	OB0C 5000-24VDC.....	5/67	1SNA645525R2400	OBROC 1500-24VAC/DC.....	5/67
1SNA607217R0200	D 2,5/5-R121-24VDC.....	5/30	1SNA645025R2200	OB0C 1500-24VAC/DC.....	5/67	1SNA645526R2500	OBROC 1000-230VAC/DC.....	5/67
1SNA607222R0700	D 2,5/5-MP-24VDC.....	5/30	1SNA645026R2300	OB0C 1000-230VAC/DC.....	5/67	1SNA645527R2600	OBROA 1000-24VDC.....	5/67
1SNA607224R0100	D 2,5/5-MP.....	5/30	1SNA645027R2400	OBOA 1000-24VDC.....	5/67	1SNA645528R0700	OBROA 1000-230VAC/DC.....	5/67
1SNA607231R0000	D 2,5/5-R121AL-24VAC/DC.....	5/30	1SNA645028R0500	OBOA 1000-230VAC/DC.....	5/67	1SNA645529R0000	OBROA 2000-24VDC.....	5/67
1SNA607232R0100	D 2,5/5-R121AL-48VAC/DC.....	5/30	1SNA645029R0600	OBOA 2000-24VDC.....	5/67	1SNA645532R2300	RB 121 AI-24VAC/DC.....	5/54
1SNA607238R1700	D 2,5/5-OBOA-1000-24VDC.....	5/36	1SNA645032R2100	RB 121 AI-24VAC/DC.....	5/54	1SNA645533R2400	RB 121 AI-24VAC/DC.....	5/54
1SNA607240R2500	D 2,5/5-OBOA-1000-24VAC/DC.....	5/36	1SNA645033R2200	RB 121 AI-24VAC/DC.....	5/54	1SNA645534R2500	RB 121-5VDC.....	5/53
1SNA607241R1200	D 2,5/5-OBOA-1000-48VAC/DC.....	5/36	1SNA645034R2300	RB 121-5VDC.....	5/53	1SNA645536R2700	RB 121-5VDC.....	5/53
1SNA607250R2700	D 2,5/5-OB0C-1000-24VAC/DC.....	5/36	1SNA645036R2500	RB 121-5VDC.....	5/53	1SNA645537R2000	RB 121-12VDC.....	5/53
1SNA607251R1400	D 2,5/5-OB0C-1000-48VAC/DC.....	5/36	1SNA645037R2600	RB 121-12VDC.....	5/53	1SNA645540R1700	RBR 122 A-48-60VAC/DC.....	5/54
1SNA607255R1000	D 2,5/5-OB0C-2000-24VAC/DC.....	5/36	1SNA645040R1500	RB 122 A-48-60VAC/DC.....	5/54	1SNA645541R0400	RBR 122 A-115VAC/DC.....	5/54
1SNA607256R1100	D 2,5/5-OB0C-2000-48VAC/DC.....	5/36	1SNA645041R0200	RB 122 A-115VAC/DC.....	5/54	1SNA645546R0100	RB 121 AR-115VAC/DC.....	5/54
1SNA607260R2100	D 2,5/5-MP-24VAC/DC.....	5/30	1SNA645046R0700	RB 121 AR-115VAC/DC.....	5/54	1SNA645547R0200	OBRIC 0100-5-12VDC.....	5/67
1SNA607261R1600	D 2,5/5-MP-48VAC/DC.....	5/30	1SNA645047R0000	OBIC 0100-5-12VDC.....	5/67	1SNA645549R1400	OBRIC 0100-48-60VAC/DC.....	5/67
1SNA607264R1100	D 2,5/5-R121BL-110VAC.....	5/30	1SNA645049R1200	OBIC 0100-48-60VAC/DC.....	5/67	1SNA645550R1100	OBROC 1000-5-12VDC.....	5/67
1SNA607265R1200	D 2,5/5-R121BL-230VAC.....	5/30	1SNA645050R1700	OB0C 1000-5-12VDC.....	5/67	1SNA645551R0600	OBROC 1000-24VDC.....	5/67
1SNA607266R1300	D 2,5/5-MP-110VAC.....	5/30	1SNA645051R0400	OB0C 1000-24VDC.....	5/67	1SNA645553R0000	OBROC 1000-48-60VAC/DC.....	5/67
1SNA607267R1400	D 2,5/5-MP-230VAC.....	5/30	1SNA645053R0600	OB0C 1000-48-60VAC/DC.....	5/67	1SNA645554R0100	OBROC 1000-115VAC/DC.....	5/67
1SNA607268R2500	D 2,5/5-OBOA-1000-110VAC.....	5/36	1SNA645054R0700	OB0C 1000-115VAC/DC.....	5/67	1SNA645558R1500	OBROC 5000-115VAC/DC.....	5/67
			1SNA645058R1300	OB0C 5000-115VAC/DC.....	5/67	1SNA645559R1600	OBROC 5000-230VAC/DC.....	5/67
			1SNA645059R1400	OB0C 5000-230VAC/DC.....	5/67	1SNA645561R0000	OBROA 1000-48-60VAC/DC.....	5/67

Index Numerical

Order code	Type	Page	Order code	Type	Page	Order code	Type	Page
1SNA645562R0100	OBROA 1000-115VAC/DC.....	5/67	1SVR011711R1600	CC-E V/I.....	4/8	1SVR011782R0700	CC-E IAC/I.....	4/11
1SNA645563R0200	RBR 111 AI-24VAC/DC.....	5/53	1SVR011712R1700	CC-E V/I.....	4/8	1SVR011783R0000	CC-E IDC/V.....	4/11
1SNA645564R0300	RB 121-24VDC.....	5/53	1SVR011713R1000	CC-E I/V.....	4/8	1SVR011784R0100	CC-E IDC/I.....	4/11
1SNA645565R0400	RB 121-24VDC.....	5/53	1SVR011714R1100	CC-E I/I.....	4/8	1SVR011785R1100	CC-E IDC/I.....	4/11
1SNA645569R0000	RB 121-12VDC.....	5/53	1SVR011715R1200	CC-E I/I.....	4/8	1SVR011788R2400	CC-E RTD/V.....	4/9
1SNA684202R0100	ILPH RS 232.....	4/37	1SVR011716R1300	CC-E I/V.....	4/8	1SVR011789R2500	CC-E RTD/I.....	4/9
1SNA684212R2200	ILPH RS 422 - 485 / RS 422 - 485 (24 V DC power supply).....	4/37	1SVR011717R1400	CC-E I/I.....	4/8	1SVR011790R2200	CC-E RTD/I.....	4/9
1SNA684231R2500	ILPH RS 232 / RS 422-485.....	4/37	1SVR011718R2500	CC-E I/I.....	4/8	1SVR011791R1700	CC-E RTD/V.....	4/9
1SNA684232R2600	ILPH BdC /RS 422 - 485 (24 V DC power supply).....	4/37	1SVR011719R2600	CC-E V/V.....	4/8	1SVR011792R1000	CC-E RTD/I.....	4/9
1SNA684233R2700	ILPH RS 232 / RS 422-485.....	4/37	1SVR011720R2300	CC-E V/V.....	4/8	1SVR011793R1100	CC-E RTD/I.....	4/9
1SNA684234R0200	ILPH RS 232 / RS 232 (115-230 V DC power supply).....	4/37	1SVR011721R1000	CC-E V/I.....	4/8	1SVR011794R1200	CC-E RTD/V.....	4/9
1SNA684234R2000	ILPH RS 232 / RS 232 (24-48 V DC power supply).....	4/37	1SVR011722R1100	CC-E V/I.....	4/8	1SVR011795R1300	CC-E RTD/I.....	4/9
1SNA684236R2200	ILPH RS 232 / FO-S (24...42 V AC/DC power supply).....	4/37	1SVR011723R1200	CC-E V/V.....	4/8	1SVR011796R1400	CC-E RTD/I.....	4/9
1SNA684237R2300	ILPH RS 232 / FO-S (110...240 V AC/DC power supply).....	4/37	1SVR011724R1300	CC-E I/I.....	4/8	1SVR011797R1500	CC-E RTD/V.....	4/9
1SNA684238R0400	ILPH RS 232 / FO-P (24...42 V AC/DC power supply).....	4/37	1SVR011725R1400	CC-E I/I.....	4/8	1SVR011798R2600	CC-E RTD/I.....	4/9
1SNA684239R0500	ILPH RS 232 / FO-P (110...240 V AC/DC power supply).....	4/37	1SVR011726R1500	CC-E V/V.....	4/8	1SVR011799R2700	CC-E RTD/I.....	4/9
1SNA684246R0400	ILPH RS 485 / FO-S (24...42 V AC/DC power supply).....	4/37	1SVR011727R1600	CC-E I/I.....	4/8	1SVR040000R1700	CC-U/STD.....	4/21
1SNA684247R0500	ILPH RS 485 / FO-S (110...240 V AC/DC power supply).....	4/37	1SVR011728R2700	CC-E I/I.....	4/8	1SVR040001R0400	CC-U/STD.....	4/21
1SNA684248R1600	ILPH RS 485 / FO-P (24...42 V AC/DC power supply).....	4/37	1SVR011729R2000	CC-E V/V.....	4/8	1SVR040002R0500	CC-U/RTD.....	4/21
1SNA684249R1700	ILPH RS 485 / FO-P (110...240 V AC/DC power supply).....	4/37	1SVR011730R2500	CC-E RTD/V.....	4/9	1SVR040003R0600	CC-U/RTD.....	4/21
1SNA684252R0200	ILPH RS 232-RS 485 / Ethernet.....	4/37	1SVR011731R1200	CC-E RTD/I.....	4/9	1SVR040004R0700	CC-U/TC.....	4/21
1SNA684333R2300	ILPH RS 232 / RS 422-485 (24-48 V DC power supply).....	4/37	1SVR011732R1300	CC-E RTD/I.....	4/9	1SVR040005R0000	CC-U/TC.....	4/21
1SNA684334R2400	ILPH RS 232 / RS 422-485 (115-230 V DC power supply).....	4/37	1SVR011733R1400	CC-E RTD/V.....	4/9	1SVR040006R0100	CC-U/I.....	4/21
			1SVR011734R1500	CC-E RTD/I.....	4/9	1SVR040007R0200	CC-U/I.....	4/21
			1SVR011735R1600	CC-E RTD/I.....	4/9	1SVR040008R1300	CC-U/V.....	4/21
			1SVR011736R1700	CC-E RTD/V.....	4/9	1SVR040009R1400	CC-U/V.....	4/21
			1SVR011737R1000	CC-E RTD/I.....	4/9	1SVR040010R0000	CC-U/STDR.....	4/21
			1SVR011738R2100	CC-E RTD/I.....	4/9	1SVR040011R2500	CC-U/STDR.....	4/21
			1SVR011739R2200	CC-E RTD/V.....	4/9	1SVR040012R2600	CC-U/RTDR.....	4/21
			1SVR011740R0700	CC-E RTD/I.....	4/9	1SVR040013R2700	CC-U/RTDR.....	4/21
			1SVR011741R2400	CC-E RTD/I.....	4/9	1SVR040014R2000	CC-U/TCR.....	4/21
			1SVR011750R0100	CC-E TC/V.....	4/10	1SVR040015R2100	CC-U/TCR.....	4/21
			1SVR011751R2600	CC-E TC/I.....	4/10	1SVR366017R0100	MAR.01.....	1/40
			1SVR011752R2700	CC-E TC/I.....	4/10	1SVR366017R0100	MAR.01.....	1/40
			1SVR011753R2000	CC-E TC/V.....	4/10	1SVR366017R0100	MAR.01.....	2/151
			1SVR011754R2100	CC-E TC/I.....	4/10	1SVR366017R0100	MAR.01.....	4/22
			1SVR011755R2200	CC-E TC/I.....	4/10	1SVR402902R0000	CM-HE.....	2/118
			1SVR011760R0300	CC-E TC/V.....	4/10	1SVR405600R0000	CR-P024AC1.....	5/7
			1SVR011761R2000	CC-E TC/I.....	4/10	1SVR405600R1000	CR-P024DC1.....	5/7
			1SVR011762R2100	CC-E TC/I.....	4/10	1SVR405600R2000	CR-P120AC1.....	5/7
			1SVR011763R2200	CC-E TC/V.....	4/10	1SVR405600R3000	CR-P230AC1.....	5/7
			1SVR011764R2300	CC-E TC/I.....	4/10	1SVR405600R4000	CR-P012DC1.....	5/7
			1SVR011765R2400	CC-E TC/I.....	4/10	1SVR405600R5000	CR-P048AC1.....	5/7
			1SVR011770R0500	CC-E IAC/V.....	4/11	1SVR405600R6000	CR-P048DC1.....	5/7
			1SVR011771R2200	CC-E IAC/I.....	4/11	1SVR405600R7000	CR-P110AC1.....	5/7
			1SVR011772R2300	CC-E IAC/I.....	4/11	1SVR405600R8000	CR-P110DC1.....	5/7
			1SVR011773R2400	CC-E IDC/V.....	4/11	1SVR405601R0000	CR-P024AC2.....	5/7
			1SVR011774R2500	CC-E IDC/I.....	4/11	1SVR405601R1000	CR-P024DC2.....	5/7
			1SVR011775R2600	CC-E IDC/I.....	4/11	1SVR405601R2000	CR-P120AC2.....	5/7
			1SVR011780R1100	CC-E IAC/V.....	4/11	1SVR405601R3000	CR-P230AC2.....	5/7
			1SVR011781R0600	CC-E IAC/I.....	4/11	1SVR405601R4000	CR-P012DC2.....	5/7

1SVR

Index Numerical

Order code	Type	Page	Order code	Type	Page	Order code	Type	Page
1SVR405601R5000	CR-P048AC2	5/7	1SVR405612R8000	CR-M110DC3	5/8	1SVR405621R1000	CR-U024DC2	5/12
1SVR405601R6000	CR-P048DC2	5/7	1SVR405612R8100	CR-M110DC3L	5/9	1SVR405621R1100	CR-U024DC2L	5/12
1SVR405601R7000	CR-P110AC2	5/7	1SVR405612R8200	CR-M125DC3	5/8	1SVR405621R2000	CR-U120AC2	5/12
1SVR405601R8000	CR-P110DC2	5/7	1SVR405612R8300	CR-M125DC3L	5/9	1SVR405621R2100	CR-U120AC2L	5/12
1SVR405606R0000	CR-P024AC2G	5/7	1SVR405612R9000	CR-M220DC3	5/8	1SVR405621R3000	CR-U230AC2	5/12
1SVR405606R1000	CR-P024DC2	5/7	1SVR405612R9100	CR-M220DC3L	5/9	1SVR405621R3100	CR-U230AC2L	5/12
1SVR405606R3000	CR-P230AC2G	5/7	1SVR405613R0000	CR-M024AC4	5/8	1SVR405621R4000	CR-U012DC2	5/12
1SVR405606R7000	CR-P110AC2G	5/7	1SVR405613R0100	CR-M024AC4L	5/9	1SVR405621R4100	CR-U012DC2L	5/12
1SVR405611R0000	CR-M024AC2	5/8	1SVR405613R1000	CR-M024DC4	5/8	1SVR405621R5000	CR-U048AC2	5/12
1SVR405611R0100	CR-M024AC2L	5/9	1SVR405613R1100	CR-M024DC4L	5/9	1SVR405621R5100	CR-U048AC2L	5/12
1SVR405611R1000	CR-M024DC2	5/8	1SVR405613R2000	CR-M120AC4	5/8	1SVR405621R6000	CR-U048DC2	5/12
1SVR405611R1100	CR-M024DC2L	5/9	1SVR405613R2100	CR-M120AC4L	5/9	1SVR405621R6100	CR-U048DC2L	5/12
1SVR405611R2000	CR-M120AC2	5/8	1SVR405613R3000	CR-M230AC4	5/8	1SVR405621R7000	CR-U110AC2	5/12
1SVR405611R2100	CR-M120AC2L	5/9	1SVR405613R3100	CR-M230AC4L	5/9	1SVR405621R7100	CR-U110AC2L	5/12
1SVR405611R3000	CR-M230AC2	5/8	1SVR405613R4000	CR-M012DC4	5/8	1SVR405621R8000	CR-U110DC2	5/12
1SVR405611R3100	CR-M230AC2L	5/9	1SVR405613R4100	CR-M012DC4L	5/9	1SVR405621R8100	CR-U110DC2L	5/12
1SVR405611R4000	CR-M012DC2	5/8	1SVR405613R4200	CR-M060DC4	5/8	1SVR405621R9000	CR-U220DC2	5/12
1SVR405611R4100	CR-M012DC2L	5/9	1SVR405613R4300	CR-M060DC4L	5/9	1SVR405621R9100	CR-U220DC2L	5/12
1SVR405611R4200	CR-M060DC2	5/8	1SVR405613R5000	CR-M048AC4	5/8	1SVR405622R0000	CR-U024AC3	5/12
1SVR405611R4300	CR-M060DC2L	5/9	1SVR405613R5100	CR-M048AC4L	5/9	1SVR405622R0100	CR-U024AC3L	5/12
1SVR405611R5000	CR-M048AC2	5/8	1SVR405613R6000	CR-M048DC4	5/8	1SVR405622R1000	CR-U024DC3	5/12
1SVR405611R5100	CR-M048AC2L	5/9	1SVR405613R6100	CR-M048DC4L	5/9	1SVR405622R1100	CR-U024DC3L	5/12
1SVR405611R6000	CR-M048DC2	5/8	1SVR405613R7000	CR-M110AC4	5/8	1SVR405622R2000	CR-U120AC3	5/12
1SVR405611R6100	CR-M048DC2L	5/9	1SVR405613R7100	CR-M110AC4L	5/9	1SVR405622R2100	CR-U120AC3L	5/12
1SVR405611R7000	CR-M110AC2	5/8	1SVR405613R8000	CR-M110DC4	5/8	1SVR405622R3000	CR-U230AC3	5/12
1SVR405611R7100	CR-M110AC2L	5/9	1SVR405613R8100	CR-M110DC4L	5/9	1SVR405622R3100	CR-U230AC3L	5/12
1SVR405611R8000	CR-M110DC2	5/8	1SVR405613R8200	CR-M125DC4	5/8	1SVR405622R4000	CR-U012DC3	5/12
1SVR405611R8100	CR-M110DC2L	5/9	1SVR405613R8300	CR-M125DC4L	5/9	1SVR405622R4100	CR-U012DC3L	5/12
1SVR405611R8200	CR-M125DC2	5/8	1SVR405613R9000	CR-M220DC4	5/8	1SVR405622R5000	CR-U048AC3	5/12
1SVR405611R8300	CR-M125DC2L	5/9	1SVR405613R9100	CR-M220DC4L	5/9	1SVR405622R5100	CR-U048AC3L	5/12
1SVR405611R9000	CR-M220DC2	5/8	1SVR405614R1100	CR-M024DC4LD	5/9	1SVR405622R5200	CR-U060AC3	5/12
1SVR405611R9100	CR-M220DC2L	5/9	1SVR405618R0000	CR-M024AC4G	5/9	1SVR405622R6000	CR-U048DC3	5/12
1SVR405612R0000	CR-M024AC3	5/8	1SVR405618R0100	CR-M024AC4LG	5/10	1SVR405622R6100	CR-U048DC3L	5/12
1SVR405612R0100	CR-M024AC3L	5/9	1SVR405618R1000	CR-M024DC4G	5/9	1SVR405622R7000	CR-U110AC3	5/12
1SVR405612R1000	CR-M024DC3	5/8	1SVR405618R1100	CR-M024DC4LG	5/10	1SVR405622R7100	CR-U110AC3L	5/12
1SVR405612R1100	CR-M024DC3L	5/9	1SVR405618R1400	CR-M024DC4LDG	5/10	1SVR405622R8000	CR-U110DC3	5/12
1SVR405612R2000	CR-M120AC3	5/8	1SVR405618R2100	CR-M120AC4LG	5/10	1SVR405622R8100	CR-U110DC3L	5/12
1SVR405612R2100	CR-M120AC3L	5/9	1SVR405618R3000	CR-M230AC4G	5/9	1SVR405622R8200	CR-U125DC3	5/12
1SVR405612R3000	CR-M230AC3	5/8	1SVR405618R3100	CR-M230AC4LG	5/10	1SVR405622R9000	CR-U220DC3	5/12
1SVR405612R3100	CR-M230AC3L	5/9	1SVR405618R4100	CR-M012DC4LG	5/10	1SVR405622R9100	CR-U220DC3L	5/12
1SVR405612R4000	CR-M012DC3	5/8	1SVR405618R4300	CR-M060DC4LG	5/10	1SVR405650R0000	CR-PLS	5/7
1SVR405612R4100	CR-M012DC3L	5/9	1SVR405618R4400	CR-M012DC4LDG	5/10	1SVR405650R0100	CR-PLSx	5/7
1SVR405612R4200	CR-M060DC3	5/8	1SVR405618R5100	CR-M048AC4LG	5/10	1SVR405650R0200	CR-PLC	5/7
1SVR405612R4300	CR-M060DC3L	5/9	1SVR405618R6100	CR-M048DC4LG	5/10	1SVR405650R1000	CR-PSS	5/7
1SVR405612R5000	CR-M048AC3	5/8	1SVR405618R7000	CR-M110AC4G	5/9	1SVR405651R0000	CR-P/M 22	5/11
1SVR405612R5100	CR-M048AC3L	5/9	1SVR405618R7100	CR-M110AC4LG	5/10	1SVR405651R1000	CR-M2SS	5/10
1SVR405612R5200	CR-M060AC3	5/8	1SVR405618R8100	CR-M110DC4LG	5/10	1SVR405651R1100	CR-M2LS	5/10
1SVR405612R6000	CR-M048DC3	5/8	1SVR405618R8300	CR-M125DC4LG	5/10	1SVR405651R1200	CR-M2LC	5/10
1SVR405612R6100	CR-M048DC3L	5/9	1SVR405618R9100	CR-M220DC4LG	5/10	1SVR405651R1300	CR-M2SF	5/10
1SVR405612R7000	CR-M110AC3	5/8	1SVR405621R0000	CR-U024AC2	5/12	1SVR405651R2000	CR-M3SS	5/10
1SVR405612R7100	CR-M110AC3L	5/9	1SVR405621R0100	CR-U024AC2L	5/12	1SVR405651R2100	CR-M3LS	5/10

Index Numerical

Order code	Type	Page	Order code	Type	Page	Order code	Type	Page
1SVR405651R3000	CR-M4SS	5/10	1SVR405664R1100	CR-U 91V	5/13	1SVR427057R0000	CP-T 24/40.0	3/34
1SVR405651R3100	CR-M4LS	5/10	1SVR405664R4000	CR-U 61E	5/13	1SVR427060R0300	CP-B 24/3.0	3/68
1SVR405651R3200	CR-M4LC	5/10	1SVR405664R4100	CR-U 61EV	5/13	1SVR427060R1000	CP-B 24/10.0	3/68
1SVR405651R3300	CR-M4SF	5/10	1SVR405665R0000	CR-U 61C	5/13	1SVR427060R2000	CP-B 24/20.0	3/68
1SVR405652R0000	CR-P/M 42	5/11	1SVR405665R0100	CR-U 91C	5/13	1SVR427065R0000	CP-B EXT.2	3/68
1SVR405652R1000	CR-P/M 42V	5/11	1SVR405665R1000	CR-U 61CV	5/13	1SVR427071R0000	CP-A RU	3/51
1SVR405652R4000	CR-P/M 42B	5/11	1SVR405665R1100	CR-U 91CV	5/13	1SVR427075R0000	CP-A CM	3/51
1SVR405652R4100	CR-P/M 42BV	5/11	1SVR405665R4000	CR-U 61D	5/13	1SVR427081R0000	CP-C MM	3/45
1SVR405652R9000	CR-P/M 42C	5/11	1SVR405665R4100	CR-U 61DV	5/13	1SVR427090R0280	CP-ASI/2.8	3/60
1SVR405652R9100	CR-P/M 42CV	5/11	1SVR405666R0000	CR-U 71	5/13	1SVR427090R0400	CP-ASI/4.0	3/60
1SVR405653R0000	CR-P/M 52B	5/11	1SVR405666R1000	CR-U 71A	5/13	1SVR427090R0800	CP-ASI/8.0	3/60
1SVR405653R1000	CR-P/M 52C	5/11	1SVR405666R2000	CR-U 81	5/13	1SVR427095R0400	CP-ASI/4.0 DC/DC	3/60
1SVR405653R4000	CR-P/M 52D	5/11	1SVR405667R0000	CR-U T	5/13	1SVR430005R0100	COV.01	1/40
1SVR405654R0000	CR-P/M 62	5/11	1SVR405669R0000	CR-UH	5/12	1SVR430005R0100	COV.01	2/151
1SVR405654R0100	CR-P/M 92	5/11	1SVR405670R0000	CR-U2S	5/12	1SVR430005R0100	COV.01	4/22
1SVR405654R1000	CR-P/M 62V	5/11	1SVR405670R1100	CR-U2SM	5/12	1SVR430029R0100	ADP.01	1/40
1SVR405654R1100	CR-P/M 92V	5/11	1SVR423418R9000	CP-RUD	3/51	1SVR430029R0100	ADP.01	1/40
1SVR405654R4000	CR-P/M 62E	5/11	1SVR427014R0000	CP-S 24/5.0	3/45	1SVR430029R0100	ADP.01	2/151
1SVR405654R4100	CR-P/M 62EV	5/11	1SVR427015R0100	CP-S 24/10.0	3/45	1SVR430029R0100	ADP.01	4/22
1SVR405655R0000	CR-P/M 62C	5/11	1SVR427016R0100	CP-S 24/20.0	3/45	1SVR430043R0000	MAR.02	1/40
1SVR405655R0100	CR-P/M 92C	5/11	1SVR427024R0000	CP-C 24/5.0	3/45	1SVR430043R0000	MAR.02	2/151
1SVR405655R1000	CR-P/M 62CV	5/11	1SVR427025R0000	CP-C 24/10.0	3/45	1SVR430220R9100	CT-IRS.16	1/38
1SVR405655R1100	CR-P/M 92CV	5/11	1SVR427026R0000	CP-C 24/20.0	3/45	1SVR430220R9300	CT-IRS.26	1/38
1SVR405655R4000	CR-P/M 62D	5/11	1SVR427030R0000	CP-E 24/0.75	3/20	1SVR430220R9400	CT-IRS.36	1/38
1SVR405655R4100	CR-P/M 62DV	5/11	1SVR427030R2000	CP-E 48/0.62	3/20	1SVR430221R1400	CT-IRS.35	1/38
1SVR405656R0000	CR-P/M 72	5/11	1SVR427031R0000	CP-E 24/1.25	3/20	1SVR430221R7100	CT-IRS.14	1/38
1SVR405656R1000	CR-P/M 72A	5/11	1SVR427031R2000	CP-E 48/1.25	3/20	1SVR430221R7300	CT-IRS.24	1/38
1SVR405656R2000	CR-P/M 82	5/11	1SVR427032R0000	CP-E 24/2.5	3/20	1SVR430230R9300	CT-IRS.26G	1/38
1SVR405658R0000	CR-PM	5/7	1SVR427032R1000	CP-E 12/2.5	3/20	1SVR430231R7300	CT-IRS.24G	1/38
1SVR405658R1000	CR-MM	5/10	1SVR427033R3000	CP-E 5/3.0	3/20	1SVR430261R5000	CT-VBS.18	1/38
1SVR405658R5000	CR-PJ	5/7	1SVR427034R0000	CP-E 24/5.0	3/20	1SVR430261R6000	CT-VBS.17	1/38
1SVR405658R6000	CR-MJ	5/10	1SVR427034R2000	CP-E 48/5.0	3/20	1SVR430500R2300	CM-SIS	2/136
1SVR405659R0000	CR-PH	5/7	1SVR427035R0000	CP-E 24/10.0	3/20	1SVR430710R0200	CM-MSS (6)	2/96
1SVR405659R1000	CR-MH	5/10	1SVR427035R1000	CP-E 12/10.0	3/20	1SVR430710R9300	CM-MSS (3)	2/96
1SVR405659R1100	CR-MH1	5/10	1SVR427035R2000	CP-E 48/10.0	3/20	1SVR430711R0300	CM-MSS (3)	2/96
1SVR405660R0000	CR-U3S	5/12	1SVR427036R0000	CP-E 24/20.0	3/20	1SVR430711R1300	CM-MSS (3)	2/96
1SVR405660R0100	CR-U3E	5/12	1SVR427041R0000	CP-D 24/0.42	3/10	1SVR430711R2300	CM-MSS (3)	2/96
1SVR405660R1100	CR-U3SM	5/12	1SVR427041R0000	CP-D 24/0.42	7/8	1SVR430720R0300	CM-MSS (5)	2/96
1SVR405661R0000	CR-U 21	5/13	1SVR427041R1000	CP-D 12/0.83	3/10	1SVR430720R0400	CM-MSS (4)	2/96
1SVR405662R0000	CR-U 41	5/13	1SVR427043R0100	CP-D 24/1.3	3/10	1SVR430720R0500	CM-MSS (7)	2/96
1SVR405662R1000	CR-U 41V	5/13	1SVR427043R0100	CP-D 24/1.3	7/8	1SVR430800R9100	CM-MSS (1)	2/96
1SVR405662R4000	CR-U 41B	5/13	1SVR427043R1200	CP-D 12/2.1	3/10	1SVR430801R1100	CM-MSS (1)	2/96
1SVR405662R9000	CR-U 41C	5/13	1SVR427044R0200	CP-D 24/2.5	3/10	1SVR430810R9300	CM-MSS (2)	2/96
1SVR405662R9100	CR-U 41CV	5/13	1SVR427045R0400	CP-D 24/4.2	3/10	1SVR430811R0300	CM-MSS (2)	2/96
1SVR405663R0000	CR-U 51B	5/13	1SVR427049R0000	CP-D RU	3/51	1SVR430811R1300	CM-MSS (2)	2/96
1SVR405663R1000	CR-U 51C	5/13	1SVR427054R0000	CP-T 24/5.0	3/34	1SVR430811R9300	CM-MSS (2)	2/96
1SVR405663R4000	CR-U 51D	5/13	1SVR427054R2000	CP-E 48/5.0	3/34	1SVR430851R0100	CM-ENS	2/117
1SVR405664R0000	CR-U 61	5/13	1SVR427055R0000	CP-T 24/10.0	3/34	1SVR430851R0200	CM-ENS UP/DOWN	2/117
1SVR405664R0100	CR-U 91	5/13	1SVR427055R2000	CP-E 48/10.0	3/34	1SVR430851R1100	CM-ENS	2/117
1SVR405664R0100	CR-U 91	5/13	1SVR427056R0000	CP-T 24/20.0	3/34	1SVR430851R1200	CM-ENS UP/DOWN	2/117
1SVR405664R1000	CR-U 61V	5/13	1SVR427056R2000	CP-E 48/20.0	3/34	1SVR430851R1300	CM-ENS	2/117

Index Numerical

Order code	Type	Page	Order code	Type	Page	Order code	Type	Page
1SVR430851R2100	CM-ENS	2/117	1SVR440851R2000	CL-LDR.17DC2	7/9	1SVR450117R1200	CM-CT 400/1	2/152
1SVR430851R9100	CM-ENS	2/117	1SVR440851R3000	CL-LDT.17DC2	7/9	1SVR450117R1300	CM-CT 500/1	2/152
1SVR430851R9200	CM-ENS UP/DOWN	2/117	1SVR440853R0000	CL-LDR.16AC2	7/9	1SVR450117R1400	CM-CT 600/1	2/152
1SVR430896R000	CM-WDS	2/142	1SVR440899R1000	CL-LAD.FD001	7/9	1SVR450117R5100	CM-CT 300/5	2/152
1SVR440005R0100	COV.02	2/151	1SVR440899R2000	CL-LAD.FD011	7/9	1SVR450117R5200	CM-CT 400/5	2/152
1SVR440029R0100	ADP.02	2/151	1SVR440899R3000	CL-LAD.FD002	7/9	1SVR450117R5300	CM-CT 500/5	2/152
1SVR440709R0000	CL-LEC.CI000	7/7	1SVR440899R6000	CL-LAD.TK001	7/9	1SVR450117R5400	CM-CT 600/5	2/152
1SVR440709R5000	CL-LER.2O	7/7	1SVR440899R6100	CL-LAD.TK002	7/9	1SVR450118R1000	CM-CT A	2/152
1SVR440710R0200	CL-LSR.CX12DC1	7/6	1SVR440899R6200	CL-LAD.TK003	7/9	1SVR450330R0000	CM-LWN	2/82
1SVR440710R0300	CL-LSR.C12DC1	7/6	1SVR440899R6300	CL-LAD.TK004	7/9	1SVR450330R0100	CM-LWN	2/82
1SVR440711R0100	CL-LSR.12DC2	7/6	1SVR440899R6400	CL-LAD.TK005	7/9	1SVR450331R0000	CM-LWN	2/82
1SVR440711R0200	CL-LSR.CX12DC2	7/6	1SVR440899R6500	CL-LAD.TK006	7/9	1SVR450331R0100	CM-LWN	2/82
1SVR440711R0300	CL-LSR.C12DC2	7/6	1SVR440899R6600	CL-LAD.TK007	7/8	1SVR450332R0000	CM-LWN	2/82
1SVR440711R1200	CL-LST.CX12DC2	7/6	1SVR440899R6700	CL-LAD.TK011	7/9	1SVR450332R0100	CM-LWN	2/82
1SVR440711R1300	CL-LST.C12DC2	7/6	1SVR440899R6900	CL-LAD.TK009	7/9	1SVR450334R0000	CM-LWN	2/82
1SVR440712R0200	CL-LSR.CX12AC1	7/6	1SVR440899R7000	CL-LAD.MD004	7/9	1SVR450334R0100	CM-LWN	2/82
1SVR440712R0300	CL-LSR.C12AC1	7/6	1SVR450025R0100	CM-MSN	2/96	1SVR450335R0000	CM-LWN	2/82
1SVR440713R0100	CL-LSR.12AC2	7/6	1SVR450050R0000	CM-ENN	2/117	1SVR450335R0100	CM-LWN	2/82
1SVR440713R0200	CL-LSR.CX12AC2	7/6	1SVR450050R0100	CM-ENN UP/DOWN	2/117	1SVR500020R0000	CT-MFD.12	1/8
1SVR440713R0300	CL-LSR.C12AC2	7/6	1SVR450051R0000	CM-ENN	2/117	1SVR500020R1100	CT-MFD.21	1/8
1SVR440720R0200	CL-LMR.CX18DC1	7/7	1SVR450051R0100	CM-ENN UP/DOWN	2/117	1SVR500100R0000	CT-ERD.12	1/8
1SVR440720R0300	CL-LMR.C18DC1	7/7	1SVR450052R0000	CM-ENN	2/117	1SVR500100R0100	CT-ERD.22	1/8
1SVR440721R0000	CL-LER.18DC2	7/7	1SVR450052R0100	CM-ENN UP/DOWN	2/117	1SVR500110R0000	CT-AHD.12	1/8
1SVR440721R0200	CL-LMR.CX18DC2	7/7	1SVR450055R0000	CM-ENN	2/117	1SVR500110R0100	CT-AHD.22	1/8
1SVR440721R0300	CL-LMR.C18DC2	7/7	1SVR450056R0000	CM-SE-300	2/118	1SVR500130R0000	CT-VWD.12	1/8
1SVR440721R1000	CL-LET.20DC2	7/7	1SVR450056R0100	CM-SE-600	2/118	1SVR500150R0000	CT-EBD.12	1/8
1SVR440721R1200	CL-LMT.CX20DC2	7/7	1SVR450056R0200	CM-SE-1000	2/118	1SVR500160R0000	CT-TGD.12	1/8
1SVR440721R1300	CL-LMT.C20DC2	7/7	1SVR450056R6000	CM-KH-3	2/118	1SVR500160R0100	CT-TGD.22	1/8
1SVR440722R0200	CL-LMR.CX18AC1	7/7	1SVR450056R7000	CM-AH-3	2/118	1SVR500210R0100	CT-SAD.22	1/8
1SVR440722R0300	CL-LMR.C18AC1	7/7	1SVR450056R8000	CM-GM-1	2/118	1SVR500211R0100	CT-SDD.22	1/8
1SVR440723R0000	CL-LER.18AC2	7/7	1SVR450059R0000	CM-ENN	2/117	1SVR510730R0300	CM-UFD.M21	2/55
1SVR440723R0200	CL-LMR.CX18AC2	7/7	1SVR450059R0100	CM-ENN UP/DOWN	2/117	1SVR550019R0000	CT-MKE	1/21
1SVR440723R0300	CL-LMR.C18AC2	7/7	1SVR450080R0000	CM-KRN	2/130	1SVR550029R8100	CT-MFE	1/20
1SVR440799R5000	CL-LAS.FD001	7/8	1SVR450081R0000	CM-KRN	2/130	1SVR550100R1100	CT-ERE	1/20
1SVR440799R5100	CL-LAS.TK011	7/8	1SVR450082R0000	CM-KRN	2/130	1SVR550100R2100	CT-ERE	1/20
1SVR440799R6000	CL-LAS.TK001	7/8	1SVR450089R0000	CM-KRN	2/130	1SVR550100R4100	CT-ERE	1/20
1SVR440799R6100	CL-LAS.TK002	7/8	1SVR450090R0000	CM-KRN	2/130	1SVR550100R5100	CT-ERE	1/20
1SVR440799R7000	CL-LAS.MD003	7/8	1SVR450091R0000	CM-KRN	2/130	1SVR550107R1100	CT-ERE	1/20
1SVR440799R8000	CL-LAS.PS002	7/8	1SVR450099R0000	CM-KRN	2/130	1SVR550107R2100	CT-ERE	1/20
1SVR440821R0000	CL-LDC.LDC2	7/9	1SVR450099R1000	CM-KRN	2/130	1SVR550107R4100	CT-ERE	1/20
1SVR440821R1000	CL-LDC.LNDC2	7/9	1SVR450116R1000	CM-CT 50/1	2/152	1SVR550107R5100	CT-ERE	1/20
1SVR440823R0000	CL-LDC.LAC2	7/9	1SVR450116R1100	CM-CT 75/1	2/152	1SVR550110R1100	CT-AHE	1/20
1SVR440823R1000	CL-LDC.LNAC2	7/9	1SVR450116R1200	CM-CT 100/1	2/152	1SVR550110R2100	CT-AHE	1/20
1SVR440839R4400	CL-LDD.K	7/6	1SVR450116R1300	CM-CT 150/1	2/152	1SVR550110R4100	CT-AHE	1/20
1SVR440839R4400	CL-LDD.K	7/9	1SVR450116R1400	CM-CT 200/1	2/152	1SVR550111R1100	CT-AHE	1/20
1SVR440839R4500	CL-LDD.XK	7/6	1SVR450116R5000	CM-CT 50/5	2/152	1SVR550111R2100	CT-AHE	1/20
1SVR440839R4500	CL-LDD.XK	7/9	1SVR450116R5100	CM-CT 75/5	2/152	1SVR550111R4100	CT-AHE	1/20
1SVR440841R0000	CL-LDC.SDC2	7/6	1SVR450116R5200	CM-CT 100/5	2/152	1SVR550118R1100	CT-AHE	1/20
1SVR440843R0000	CL-LDC.SAC2	7/6	1SVR450116R5300	CM-CT 150/5	2/152	1SVR550118R2100	CT-AHE	1/20
1SVR440851R0000	CL-LDR.16DC2	7/9	1SVR450116R5400	CM-CT 200/5	2/152	1SVR550118R4100	CT-AHE	1/20
1SVR440851R1000	CL-LDT.16DC2	7/9	1SVR450117R1100	CM-CT 300/1	2/152	1SVR550120R1100	CT-ARE	1/20

Index Numerical

Order code	Type	Page	Order code	Type	Page	Order code	Type	Page
1SVR550120R4100	CT-ARE	1/20	1SVR550855R9500	CM-ENE MIN	2/117	1SVR730831R1400	CM-ESS.2S	2/16
1SVR550127R1100	CT-ARE	1/20	1SVR550870R9400	CM-PVE	2/33	1SVR730840R0200	CM-SRS.11S	2/15
1SVR550127R4100	CT-ARE	1/20	1SVR550871R9500	CM-PVE	2/33	1SVR730840R0300	CM-SRS.12S	2/15
1SVR550130R1100	CT-VWE	1/20	1SVR550881R9400	CM-PBE	2/33	1SVR730840R0400	CM-SRS.21S	2/15
1SVR550130R2100	CT-VWE	1/20	1SVR550882R9500	CM-PBE	2/33	1SVR730840R0500	CM-SRS.22S	2/15
1SVR550130R4100	CT-VWE	1/20	1SVR560730R3400	CM-UFD.M22	2/55	1SVR730840R0600	CM-SRS.M1S	2/15
1SVR550137R1100	CT-VWE	1/20	1SVR630736R0300	CM-UFS.1	2/55	1SVR730840R0700	CM-SRS.M2S	2/15
1SVR550137R2100	CT-VWE	1/20	1SVR700101R0100	C512-D	2/106	1SVR730841R0200	CM-SRS.11S	2/15
1SVR550137R4100	CT-VWE	1/20	1SVR700102R0100	C512-E	2/106	1SVR730841R0300	CM-SRS.12S	2/15
1SVR550140R1100	CT-AWE	1/21	1SVR700111R0100	C513-D	2/106	1SVR730841R0400	CM-SRS.21S	2/15
1SVR550140R2100	CT-AWE	1/21	1SVR700112R0100	C513-E	2/106	1SVR730841R0500	CM-SRS.22S	2/15
1SVR550140R4100	CT-AWE	1/21	1SVR730005R0100	COV.11	1/40	1SVR730841R1200	CM-SRS.11S	2/15
1SVR550141R1100	CT-AWE	1/21	1SVR730005R0100	COV.11	2/151	1SVR730841R1300	CM-SRS.12S	2/15
1SVR550141R2100	CT-AWE	1/21	1SVR730006R0000	MAR.12	1/40	1SVR730841R1400	CM-SRS.21S	2/15
1SVR550141R4100	CT-AWE	1/21	1SVR730006R0000	MAR.12	2/151	1SVR730841R1500	CM-SRS.22S	2/15
1SVR550148R1100	CT-AWE	1/21	1SVR730010R0200	CT-MFS.21S	1/37	1SVR730884R1300	CM-MPS.31S	2/34
1SVR550148R2100	CT-AWE	1/21	1SVR730010R3200	CT-MBS.22S	1/37	1SVR730884R3300	CM-MPS.41S	2/34
1SVR550148R4100	CT-AWE	1/21	1SVR730020R0200	CT-MVS.21S	1/37	1SVR730884R4300	CM-MPS.43S	2/34
1SVR550150R3100	CT-AWE	1/20	1SVR730020R3100	CT-MVS.12S	1/37	1SVR730885R1300	CM-MPS.11S	2/34
1SVR550151R3100	CT-AWE	1/20	1SVR730020R3300	CT-MVS.22S	1/37	1SVR730885R3300	CM-MPS.21S	2/34
1SVR550158R3100	CT-AWE	1/20	1SVR730021R2300	CT-MVS.23S	1/37	1SVR730885R4300	CM-MPS.23S	2/34
1SVR550160R1100	CT-EBE	1/21	1SVR730030R3300	CT-MXS.22S	1/37	1SVR740010R0200	CT-MFS.21P	1/37
1SVR550167R1100	CT-EBE	1/21	1SVR730040R3300	CT-WBS.22S	1/37	1SVR740010R3200	CT-MBS.22P	1/37
1SVR550200R1100	CT-YDE	1/21	1SVR730100R0300	CT-ERS.21S	1/38	1SVR740020R0200	CT-MVS.21P	1/37
1SVR550200R2100	CT-YDE	1/21	1SVR730100R3100	CT-ERS.12S	1/38	1SVR740020R3100	CT-MVS.12P	1/37
1SVR550200R4100	CT-YDE	1/21	1SVR730100R3300	CT-ERS.22S	1/38	1SVR740020R3300	CT-MVS.22P	1/37
1SVR550207R1100	CT-YDE	1/21	1SVR730110R3300	CT-AHS.22S	1/38	1SVR740021R2300	CT-MVS.23P	1/37
1SVR550207R2100	CT-YDE	1/21	1SVR730120R3100	CT-ARS.11S	1/38	1SVR740030R3300	CT-MXS.22P	1/37
1SVR550207R4100	CT-YDE	1/21	1SVR730120R3300	CT-ARS.21S	1/38	1SVR740040R3300	CT-WBS.22P	1/37
1SVR550210R4100	CT-SDE	1/21	1SVR730180R0300	CT-APS.21S	1/38	1SVR740100R0300	CT-ERS.21P	1/38
1SVR550212R4100	CT-SDE	1/21	1SVR730180R3100	CT-APS.12S	1/38	1SVR740100R3100	CT-ERS.12P	1/38
1SVR550217R4100	CT-SDE	1/21	1SVR730180R3300	CT-APS.22S	1/38	1SVR740100R3300	CT-ERS.22P	1/38
1SVR550221R9100	CT-IRE	1/21	1SVR730210R3300	CT-SDS.22S	1/38	1SVR740110R3300	CT-AHS.22P	1/38
1SVR550228R9100	CT-IRE	1/21	1SVR730211R2300	CT-SDS.23S	1/38	1SVR740120R3100	CT-ARS.11P	1/38
1SVR550231R9100	CT-IRE	1/21	1SVR730660R0100	CM-IWS.1S	2/72	1SVR740120R3300	CT-ARS.21P	1/38
1SVR550238R9100	CT-IRE	1/21	1SVR730670R0200	CM-IWS.2S	2/72	1SVR740180R0300	CT-APS.21P	1/38
1SVR550509R1000	CT-EKE	1/21	1SVR730740R0100	CM-TCS.11S	2/106	1SVR740180R3100	CT-APS.12P	1/38
1SVR550509R2000	CT-EKE	1/21	1SVR730740R0200	CM-TCS.12S	2/106	1SVR740180R3300	CT-APS.22P	1/38
1SVR550509R4000	CT-EKE	1/21	1SVR730740R0300	CM-TCS.13S	2/106	1SVR740210R3300	CT-SDS.22P	1/38
1SVR550519R1000	CT-AKE	1/21	1SVR730740R9100	CM-TCS.21S	2/106	1SVR740211R2300	CT-SDS.23P	1/38
1SVR550519R2000	CT-AKE	1/21	1SVR730740R9200	CM-TCS.22S	2/106	1SVR740660R0100	CM-IWS.1P	2/72
1SVR550519R4000	CT-AKE	1/21	1SVR730740R9300	CM-TCS.23S	2/106	1SVR740670R0200	CM-IWS.2P	2/72
1SVR550800R9300	CM-MSE	2/96	1SVR730750R0400	CM-EFS.2S	2/16	1SVR740740R0100	CM-TCS.11P	2/106
1SVR550801R9300	CM-MSE	2/96	1SVR730760R0400	CM-SFS.21S	2/15	1SVR740740R0200	CM-TCS.12P	2/106
1SVR550805R9300	CM-MSE	2/96	1SVR730760R0500	CM-SFS.22S	2/15	1SVR740740R0300	CM-TCS.13P	2/106
1SVR550824R9100	CM-PFE	2/33	1SVR730830R0300	CM-ESS.1S	2/16	1SVR740740R9100	CM-TCS.21P	2/106
1SVR550850R9400	CM-ENE MAX	2/117	1SVR730830R0400	CM-ESS.2S	2/16	1SVR740740R9200	CM-TCS.22P	2/106
1SVR550850R9500	CM-ENE MIN	2/117	1SVR730830R0500	CM-ESS.MS	2/16	1SVR740740R9300	CM-TCS.23P	2/106
1SVR550851R9400	CM-ENE MAX	2/117	1SVR730831R0300	CM-ESS.1S	2/16	1SVR740750R0400	CM-EFS.2P	2/16
1SVR550851R9500	CM-ENE MIN	2/117	1SVR730831R0400	CM-ESS.2S	2/16	1SVR740760R0400	CM-SFS.21P	2/15
1SVR550855R9400	CM-ENE MAX	2/117	1SVR730831R1300	CM-ESS.1S	2/16	1SVR740830R0300	CM-ESS.1P	2/16

Index Numerical

Order code	Type	Page	Order code	Type	Page
1SVR740830R0400	CM-ESS.2P	2/16	GHC		
1SVR740830R0500	CM-ESS.MP	2/16	GHC0110003R0001	C011-70	2/97
1SVR740831R0300	CM-ESS.1P	2/16	GHC0110003R0002	C011-80	2/97
1SVR740831R0400	CM-ESS.2P	2/16	GHC0110003R0003	C011-90	2/97
1SVR740831R1300	CM-ESS.1P	2/16	GHC0110003R0004	C011-100	2/97
1SVR740831R1400	CM-ESS.2P	2/16	GHC0110003R0005	C011-110	2/97
1SVR740840R0200	CM-SRS.11P	2/15	GHC0110003R0006	C011-120	2/97
1SVR740840R0400	CM-SRS.21P	2/15	GHC0110003R0007	C011-130	2/97
1SVR740840R0600	CM-SRS.M1P	2/15	GHC0110003R0008	C011-150	2/97
1SVR740841R0200	CM-SRS.11P	2/15	GHC0110003R0009	C011-160	2/97
1SVR740841R0400	CM-SRS.21P	2/15	GHC0110003R0010	C011-170	2/97
1SVR740841R1200	CM-SRS.11P	2/15	GHC0110003R0011	C011-140	2/97
1SVR740841R1400	CM-SRS.21P	2/15	GHC011003R0008	C011-3-150	2/97
1SVR740884R1300	CM-MPS.31P	2/34	GHV6000000V0001	20-100W-MC	6/4
1SVR740884R3300	CM-MPS.41P	2/34	GHV6000000V0001	20-100W-MC	6/4
1SVR740884R4300	CM-MPS.43P	2/34	GHV6000000V0002	200-300W-MC	6/4
1SVR740885R1300	CM-MPS.11P	2/34	GHV6000000V0002	200-300W-MC	6/4
1SVR740885R3300	CM-MPS.21P	2/34	GHV6000020V0006	20W-230V-HE	6/4
1SVR740885R4300	CM-MPS.23P	2/34	GHV6000040V0004	40W-110V-HP	6/4
1SVR750005R0100	COV.12	2/151	GHV6000040V0006	40W-230V-HE	6/4
1SVR750487R8300	CM-MPN.52S	2/34	GHV6000100V0006	100W-230V-HE	6/4
1SVR750488R8300	CM-MPN.62S	2/34	GHV6000200V0006	200W-230V-HE	6/4
1SVR750489R8300	CM-MPN.72S	2/34	GHV6000300V0006	300W-230V-HE	6/4
1SVR750660R0200	CM-IWN.1S	2/72	GHV6010040V0006	40W-230V-HP	6/4
1SVR750660R0300	CM-IWN.4S	2/72	GHV6010040V0007	40W-230V-HP-E	6/4
1SVR750660R0400	CM-IWN.5S	2/72	GHV6010100V0004	100W-110V-HP	6/4
1SVR750669R9400	CM-IVN.S	2/72	GHV6010100V0006	100W-230V-HP	6/4
1SVR760487R8300	CM-MPN.52P	2/34	GHV6010100V0007	100W-230V-HP-E	6/4
1SVR760488R8300	CM-MPN.62P	2/34	GHV6010250V0004	250W-110V-HP	6/4
1SVR760489R8300	CM-MPN.72P	2/34	GHV6010250V0006	250W-230V-HP	6/4
1SVR760660R0200	CM-IWN.1P	2/72	GHV6011060V0001	Thermostat	6/4
1SVR760660R0300	CM-IWN.4P	2/72	GHV6011060V0001	Thermostat	6/4
1SVR760660R0400	CM-IWN.5P	2/72	GHV6017100V0006	100W-230V-HP-ADJ	6/4
1SVR760660R0500	CM-IWN.6S	2/72	GHV6017250V0006	250W-230V-HP-ADJ	6/4
1SVR760660R0500	CM-IWN.6P	2/72	GJD6155620R0087	SK 615 562-87	1/39
1SVR760669R9400	CM-IVN.P	2/72	GJD6155620R0088	SK 615 562-88	1/39

2CDE

2CDE601101R2001	EPD24-TB-101-1A	3/75
2CDE601101R2002	EPD24-TB-101-2A	3/75
2CDE601101R2003	EPD24-TB-101-3A	3/75
2CDE601101R2004	EPD24-TB-101-4A	3/75
2CDE601101R2006	EPD24-TB-101-6A	3/75
2CDE601101R2008	EPD24-TB-101-8A	3/75
2CDE601101R2010	EPD24-TB-101-10A	3/75
2CDE601101R2012	EPD24-TB-101-12A	3/75
2CDE601101R2905	EPD24-TB-101-0.5A	3/75
2CDE605100R0500	EPD-BB500	3/75
2CDE605200R0021	EPD-SB21	3/75

Index Notes

A series of horizontal dotted lines for writing notes.

Index Notes

A series of horizontal dotted lines for writing notes.

Index Notes

A series of horizontal dotted lines for writing notes.

Index Notes

A series of horizontal dotted lines for writing notes.

Index Notes

A series of horizontal dotted lines for writing notes.

Index Notes

A large area of the page is filled with horizontal dotted lines, providing space for writing notes or index entries.

Index Notes

A series of horizontal dotted lines for writing notes.

Contact

ABB STOTZ-KONTAKT GmbH

ABB Entelec

<http://www.abb.com/lowvoltage>

- > Control Products
- > Electronic Relays and Controls
 - > Signal Converters
 - > Power Supplies
 - > Motor Controllers

www.abb.com/contacts

Note:

We reserve the right to make technical changes or modify the contents of this document without prior notice. With regard to purchase orders, the agreed particulars shall prevail. ABB AG does not accept any responsibility whatsoever for potential errors or possible lack of information in this document.

We reserve all rights in this document and in the subject matter and illustrations contained therein. Any reproduction, disclosure to third parties or utilization of its contents – in whole or in parts – is forbidden without prior written consent of ABB AG.

Copyright© 2014 ABB
All rights reserved