ESA Series energy storage system

GW125/261-ESA-LCN-G10

User Manual

V1.0 2025.05.28

Copyright Statement:

Copyright ©GoodWe Technologies Co., Ltd. 2025. All rights reserved.

No part of this manual can be reproduced or transmitted to the public platform in any form or by any means without the prior written authorization of GoodWe Technologies Co., Ltd..

Trademarks

GOODWE and other GOODWE trademarks are trademarks of GoodWe Technologies Co., Ltd. All other trademarks or registered trademarks mentioned are owned by their original owners.

NOTICE

The information in this user manual is subject to change due to product updates or other reasons. This manual cannot replace the product labels or the safety precautions unless otherwise specified. All descriptions in the manual are for guidance only.

Contents

Trademarks	1
NOTICE	1
1 About This Manual	1
1.1 Overview	1
1.2 Applicable Model	1
1.3 Symbol Definition	1
2 Safety Precaution	1
2.1 General Safety	2
2.2 Personnel Requirements	2
2.3 System Safety	3
2.3.1 Battery Safety	5
2.3.2 Emergency Measures	5
2.3.2 Fire Extinguishing	5
2.4 Safety Symbols and Certification Marks	6
3 Product Introduction	8
3.1 Product Overview	8
3.2 Application Scenarios	8
3.3 Operating Mode	12
3.4 Appearance Description	13
3.4.1 Appearance Introduction	13
3.4.2 Size	14
3.4.3 Component Introduction	14
3.4.4 Fire Protection System	17
3.4.5 Indicators	18
3.4.6 Nameplate	19
4 Check and Storage	20

4.1 Check before Receiving	20
4.2 Deliverables	20
4.3 Storage	20
5 Installation	22
5.1 Installation Requirements	22
5.2 Energy Storage System Installation	26
5.2.1 Moving Energy Storage System	26
5.2.1 Installing Energy Storage System	27
6 Electrical Connection	28
6.1 Safety Precautions	28
6.2 Connecting the PE Cable	30
6.3 Wiring Preparation	30
6.4 Connect the AC Output Cable	31
6.5 Connection Communication Cable	32
6.5.1 Communication Port Introduction	32
6.5.2 Antenna Installing	34
6.6 MSD Switch Installation	35
6.7 Operation after Wiring	35
7 Equipment Commissioning	36
7.1 Check Items before Power On	36
7.2 Power On	36
8 System Commissioning	37
8.1 Set Inverter Parameters via Solargo	37
8.2 Set Inverter Parameters via SEC3000C Embedded Web	38
9 Power Plant Monitoring via SEMS	38
10 Maintenance	39

10.1 Power Off Energy Storage System	39
10.2 Removing Energy Storage System	40
10.3 Disposing of Energy Storage System	40
10.4 Troubleshooting	41
10.5 Routine Maintenance	50
11 Technical Parameters	53

1 About This Manual

1.1 Overview

This document primarily introduces the product information of energy storage system, installation wiring, configuration of Commissioning, fault troubleshooting, and maintenance content. Before installation or using this product, please carefully read this manual to understand the product safety information and familiarize yourself with the product's functions and features. The document may be updated periodically; please obtain the latest version and more product information from the official website.

1.2 Applicable Model

This document applies to the energy storage system (hereinafter referred to as: energy storage system) with model being GW125/261-ESA-LCN-G10:

Product model	Nominal output power	Nominal output voltage	Available energy
GW125/261-ESA-LCN-G10	125kW	400V, 3L/N/PE	261.25kWh

1.3 Symbol Definition

DANGER
Indicates a highly potential danger, which, if not avoided, will result in death or serious injury.
WARNING
Indicates a moderate potential danger, which, if not avoided, could result in death or serious injury.
CAUTION
Indicates a low potential danger, which, if not avoided, may result in moderate or minor injury to personnel.
NOTICE
Emphasis and supplementation of content may also provide tips or tricks for optimizing product use, helping you solve a problem or save time.

2 Safety Precaution

The Safety Precautions information contained in this document must always be followed when operating the equipment.

WARNING

The equipment has been strictly designed in accordance with safety regulations and has passed all required tests. However, as electrical apparatus, all operations must comply with relevant safety instructions prior to any intervention. Improper handling may result in severe injury or property damage.

2.1 General Safety

NOTICE

- Due to product version upgrades or other reasons, the document content will be updated periodically. Unless otherwise agreed, the document content cannot replace the safety precautions on the product label. All descriptions in the document are provided solely as usage guidelines.
- During transportation, storage, installation, operation, use, maintenance, and all other operations, applicable laws, regulations, standards, and specification requirements must be complied with.
- Before operating the installation equipment, please carefully read this document to understand the product and notice precautions.
- All operations of the equipment must be performed by professional and qualified electrical technicians who are well-versed in the relevant standards and safety regulations of the project location.
- When operating equipment, use insulated tools and wear personal protective equipment to ensure personal safety. When handling electronic components, wear anti-static gloves, wrist straps, and clothing to protect the equipment from electrostatic damage.
- Unauthorized disassembly or modification may cause equipment damage, which is not covered under warranty.
- Damage to equipment or personal injury caused by failure to install, use, or configure the device in accordance with this document or the applicable user manual is not covered by warranty. For more product warranty information, please visit the official website: <https://www.goodwe.com/warrantyrelated.html>

2.2 Personnel Requirements

NOTICE

- Personnel responsible for the maintenance of Installation equipment must undergo rigorous training to understand various safety precautions and master the correct operational procedures.
- Installation, operation, maintenance, and replacement of equipment or components shall only be performed by qualified professionals or trained personnel.

2.3 System Safety

DANGER

- Before making electrical connections, ensure all upstream switch of the equipment are disconnected and the device is power off. Live working is strictly prohibited to avoid electrical hazards such as danger.
- To prevent personal injury or equipment damage caused by live operation, a circuit breaker must be added to the input side of the equipment.
- During equipment transportation and handling, please comply with local laws, regulations, and industry standards. Rough handling may cause short circuits or damage to the battery pack in the system, potentially leading to electrolyte leakage, fire, or explosion.
- The energy storage system is heavy-duty equipment. Use appropriate tools and equipment and take Protection measures during Installation and maintenance. Improper operation may cause personal injury or product damage.
- The equipment contains lethal high voltage, posing an electric shock danger. Do not touch it without authorization.
- Unauthorized personnel are not allowed to open the cabinet door or touch internal components, as it may result in electric shock.
- When the equipment is in a damaged state or fault state, there may be risks of electric shock and fire. Ensure that the equipment is undamaged and free from fault before operation.
- When the equipment triggers a grounding fault alarm, it may indicate the presence of lethal high voltage, posing an electric shock danger hazard.
- Before operating the equipment, ensure the system is reliably grounded and all necessary protective measures are in place. Otherwise, there may be a risk of electric shock.
- During equipment operation, do not open the cabinet door or touch any wiring terminal or components. Otherwise, electric shock danger may occur.
- Before performing installation, wiring, or maintenance, ensure all switches of the equipment are disconnected.
- Do not disassemble or modify any part of the equipment without official authorization from the manufacturer. Damage caused by such actions will not be covered under warranty.

WARNING

- Do not strike, pull, drag, or step on the equipment; avoid puncturing the equipment casing with sharp objects, and refrain from placing unrelated items in any part of the cabinet.
- When the temperature inside the equipment exceeds 160°C, battery poses a fire hazard

and will trigger the automatic fire suppression system.

- The equipment is equipped with an automatic fire suppression system. Do not trigger the fire control switch unless in an emergency.
- Please select cables that comply with local laws and regulations.
- Ensure that the voltage and Frequency at the on-grid access point comply with energy storage system on-grid requirements.
- It is recommended to add breaker or fuses and other Protection devices on the AC side of the equipment.
- Do not place the equipment in a high-temperature environment and ensure there are no heat sources near the equipment.

2.3.1 Battery Safety

WARNING

- High voltage is present inside the battery. Before operating any equipment in the system, ensure that the device has been power off to prevent electric shock danger.
- Do not subject the battery to vibration, impact, pulling, or compression, as this may cause damage to the battery or pose a fire hazard.
- For long-term storage, regularly charge the battery pack to prevent capacity loss or irreversible damage.
- Do not use more than The nominal charging and discharging current pairs of battery to charge discharge.
- Do not use if the battery or high-voltage control unit shows obvious defects, cracks, damage, or other issues. Otherwise, it may cause personal danger.
- Battery and current may be affected by factors such as temperature, humidity, and weather conditions, which could lead to current limiting in battery and impact load-carrying capacity.
- If the battery needs to be replaced, please contact the after-sales service center.
- If the battery fails to start, please contact the after-sales service center as soon as possible; otherwise, the battery may be permanently damaged.

2.3.2 Emergency Measures

WARNING

- If battery leaks electrolyte, avoid contact with the leaked liquid or gas. The electrolyte is corrosive, and contact may cause skin irritation and chemical burn. If accidental contact with the leaked substance occurs, please perform the following actions:
- Inhalation Leaking substance: Evacuate the contaminated area and seek immediate medical assistance.
- Eye contact: Rinse with clean water for at least 15 minutes and seek immediate medical assistance.
- Skin contact: Wash the affected area thoroughly with soap and water and seek medical attention immediately.
- Ingestion: Induce vomiting and seek immediate medical attention.

2.3.2 Fire Extinguishing







WARNING



- Battery may release toxic and harmful gases after catching fire.
- In case of fire, immediately call the fire emergency number, inform the firefighters, and provide relevant product information.
- In case of fire, it is recommended to promptly disconnect the upstream and downstream switches of the equipment while ensuring personnel safety.
- Do not use ABC dry powder fire extinguishers to extinguish the fire. Firefighters must wear protective clothing and self-contained breathing apparatus.

2.4 Safety Symbols and Certification Marks

DANGER

- After the equipment Installation is installed, the labels and warning signs on the enclosure must remain clearly visible. Obstructing, altering, or damaging them is prohibited.
- The following warning labels on the enclosure are for reference only. Please refer to the actual labels on the equipment.

No.	Symbol	Meaning
1		Potential danger exists during equipment operation. Take necessary precautions when operating the device.
2		High voltage danger. The equipment operates under high voltage. Ensure the device is power off before performing any operations.
3		Energy storage system surface is at high temperature. Do not touch during operation to avoid burns.
4		Please use the equipment properly. In extreme conditions, there is a risk of explosion.
6		Delayed discharge. After power off the equipment, please wait for 5 minutes until it is completely Discharge.
7		Equipment should be kept away from open flames or ignition sources.
8		The equipment shall be accessible in the Keep away from children area.

9		Do not extinguish with water.
10		Before operating the equipment, please read the product manual in detail.
11		During Installation, operation, and maintenance, it is necessary to wear personal protective equipment.
12		The equipment must not be disposed of as household waste. Please handle the equipment in accordance with local laws and regulations or return it to the manufacturer.
13		Grounding point.
14		Recycling symbol.
15		CE marking.

3 Product Introduction

3.1 Product Overview

The GW125/261-ESA-LCN-G10 is a highly integrated outdoor all-in-one cabinet for commercial and industrial energy storage, developed based on 314Ah liquid-cooled packs and 125kW intelligent air-cooled PCS. It features high energy density, high power density, and full-stack in-house R&D with 3S (storage, PCS, system) deep integration. The liquid-cooled pack utilizes 314Ah battery cells with higher energy density, supporting 0.5P charge/discharge, and employs a parallel flow channel design for the cooling plate, which minimizes flow resistance and ensures more balanced cell temperatures. The 125kW intelligent air-cooled PCS adopts a three-level T-type topology, outputs three-phase four-wire power, supports 100% unbalanced load, enables independent phase power control, and offers strong overload capability. The unit is equipped with comprehensive fire protection configurations, with both pack-level and system-level fire suppression systems capable of meeting various customized requirements.

Supported Grid type

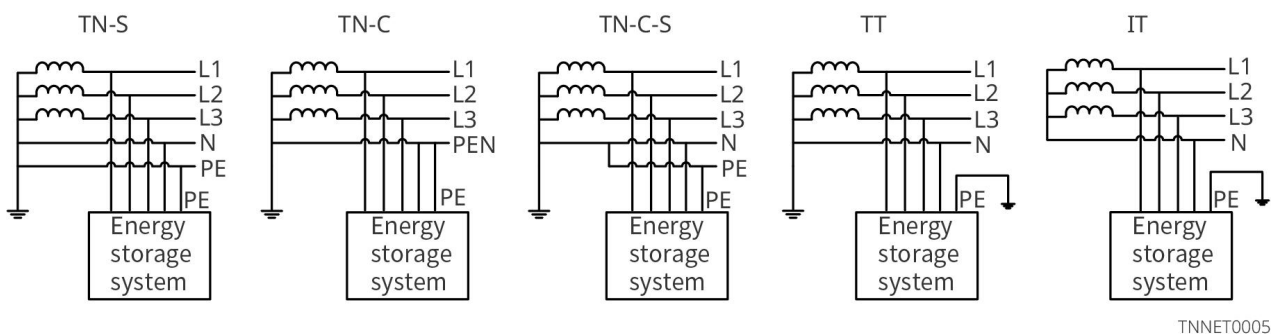

3.2 Application Scenarios

- Connecting SEC3000C

Method 1:

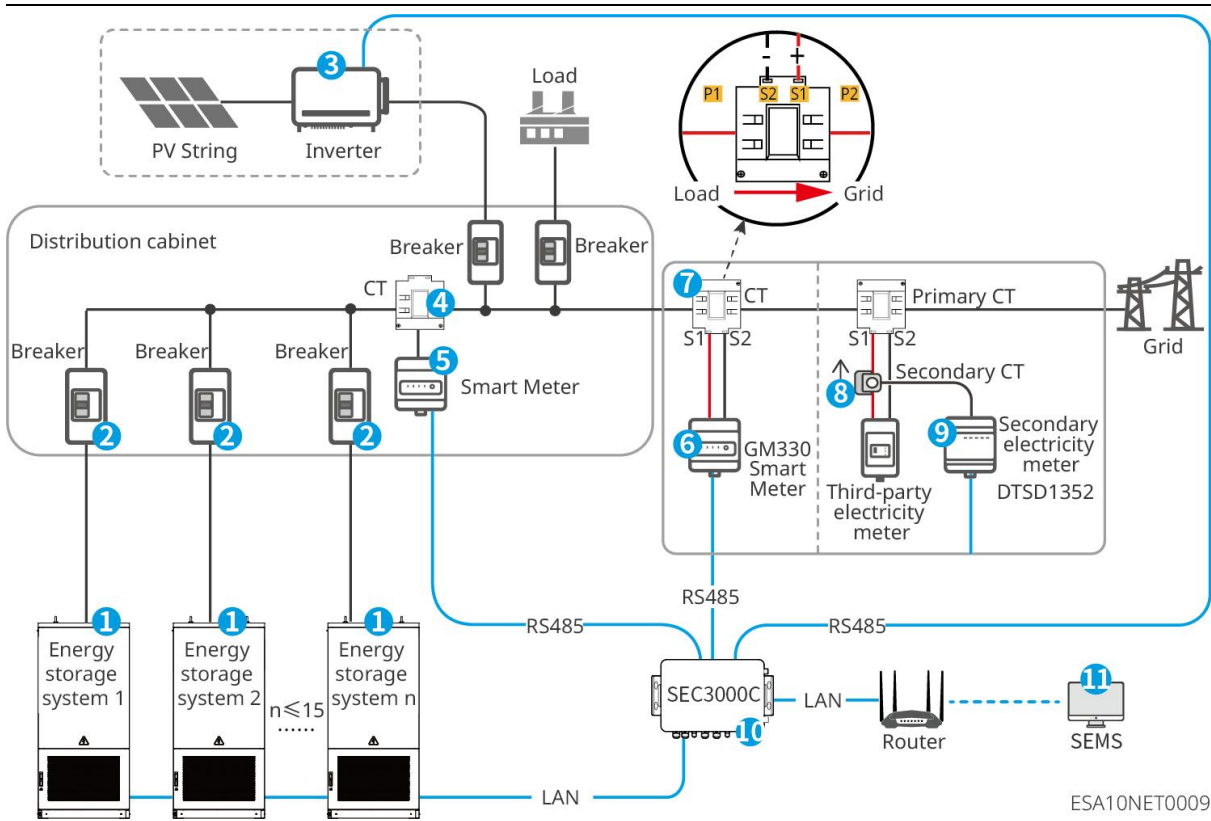

Method 2:

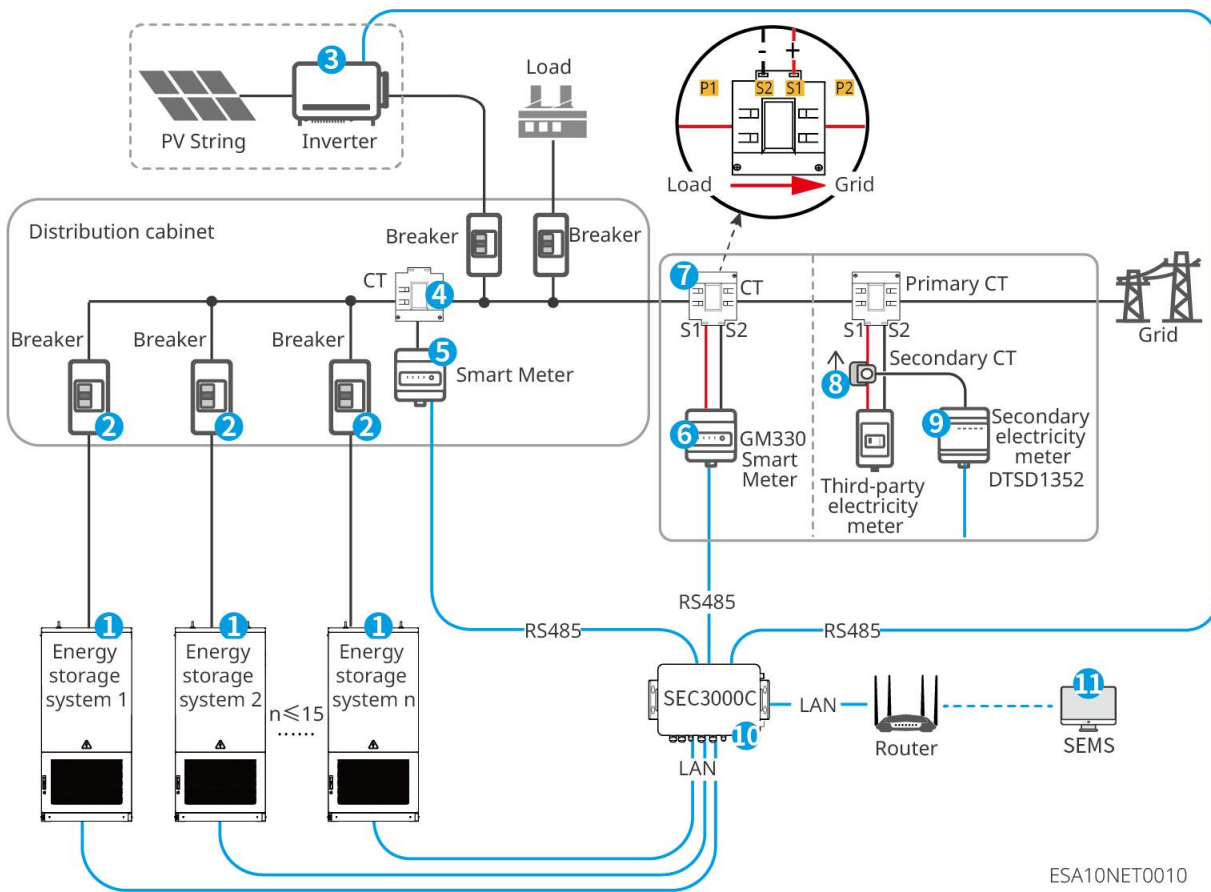

● **Connecting to third-party EMS**

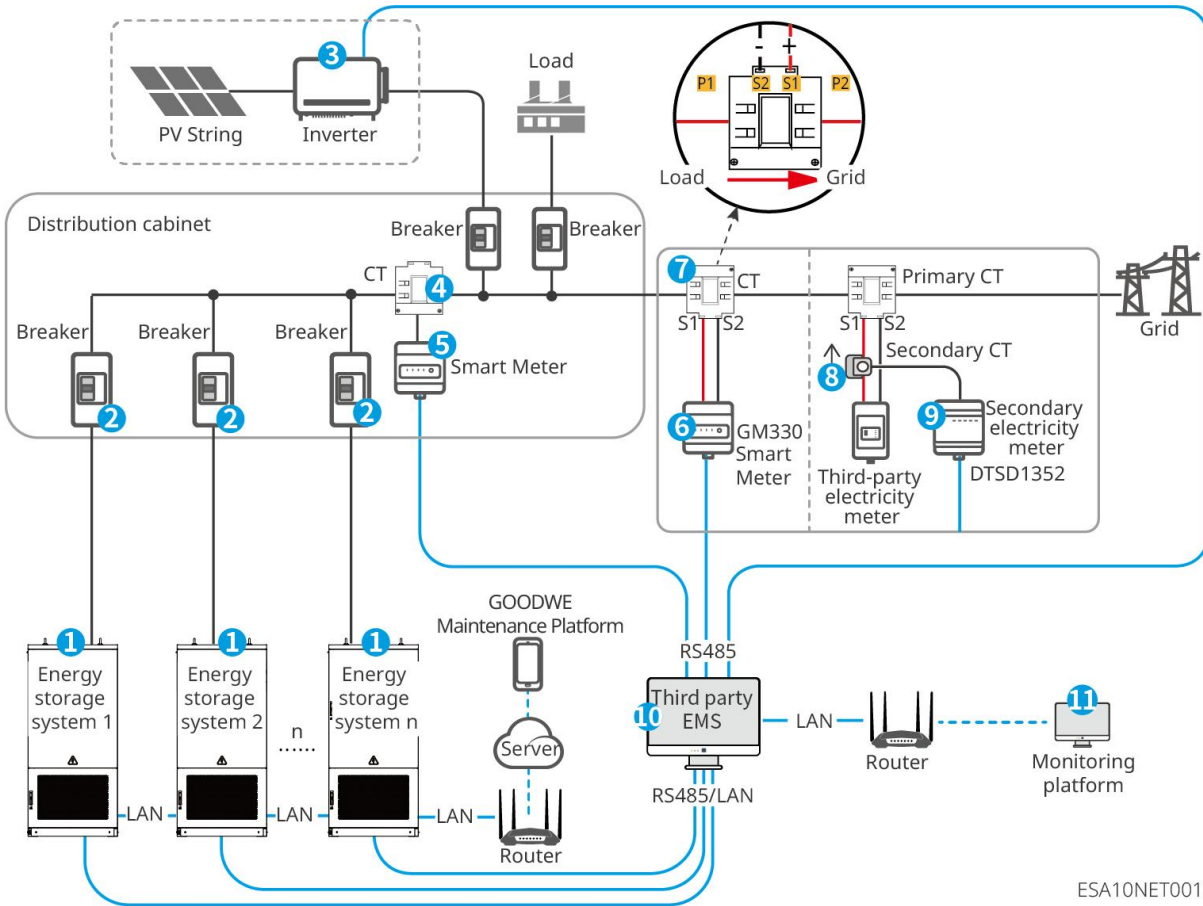

ESA10NET0011

Serial number	Name	Function
1	Energy storage system	GW125/261-ESA-LCN-G10 energy storage system
2	Breaker	Circuit breaker Protection, recommended specifications: 250A, to be provided by the user.
3	Photovoltaic grid-tied PV inverter	Convert PV DC power to AC power.
4	CT	Match according to the paired meter.
5	Smart Meter	Metering the power flow data between energy storage system and Utility grid. Supports purchasing the GM330 (recommended) from GoodWe or sourcing it independently.
6	Primary Smart Meter	For energy storage system, use export power limit. You can choose to purchase GM330 from GoodWe or buy it separately.

7	Primary CT	<p>Customer self-purchase.</p> <ul style="list-style-type: none"> ● If the primary meter uses GM330, the CT ratio is: nA/5A. <ul style="list-style-type: none"> ■ nA: CT primary side input current, the value of n is determined based on the actual specifications of the PCC point busbar or cable on-site. ■ 5A: CT secondary side outputs current. ● If the customer purchases a primary meter on their own, select the primary CT according to the meter specifications.
8	Secondary CT	The customer purchases it themselves. It is used in conjunction with the secondary Smart Meter DTSD1352, with a CT ratio of: 5A/2mA.
9	Secondary Smart Meter (DTSD1352)	Supports purchasing from GoodWe or customer self-purchase of export power limit for energy storage system.
10	SEC3000C	<p>Collect system data and transmit it to the SEMS/third-party monitoring platform to achieve centralized monitoring, operation, and maintenance of the system.</p> <ul style="list-style-type: none"> ● SEC3000C: Selected from GoodWe ● Third-party EMS: Customer-provided
	Third-party EMS	
11	SEMS	<p>Remotely view the operational data of energy storage system and configure system parameters. Available from GoodWe.</p> <ul style="list-style-type: none"> ● SEMS: Selected from GoodWe ● Third-party monitoring platform: Customer-provided
	Third-party monitoring platform	

NOTICE

If using a third-party EMS and monitoring platform, please contact GoodWe after-sales service for protocol matching of the equipment:

- Communication interface: RS485, LAN
- Communication Protocols: Modbus RTU, Modbus TCP

3.3 Operating Mode

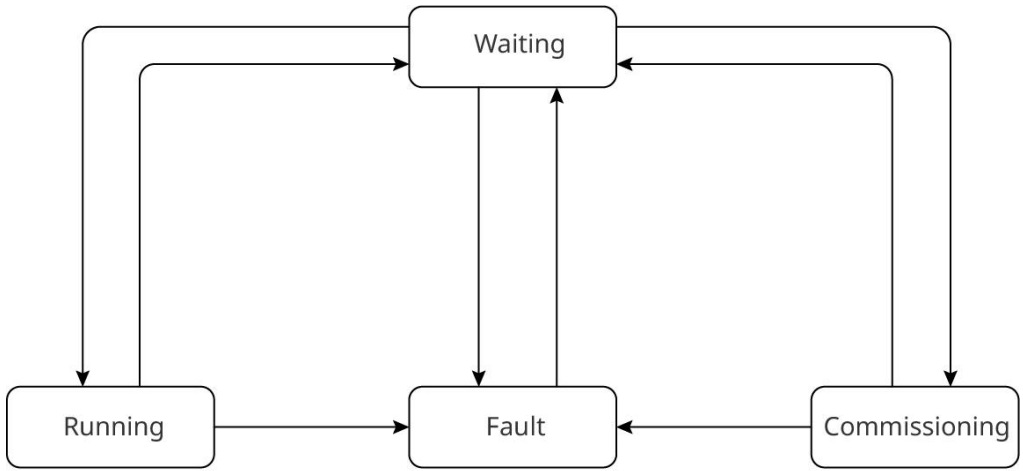

ESA10DSC0007

Serial number	Name	Instructions
1	Standby status	<p>After energy storage system is started, it performs self-check and enters the initialized state.</p> <ul style="list-style-type: none"> ● If the operation status is manually enabled, energy storage system starts running. ● If the self-check is abnormal, it will enter the fault state. ● If debugging is enabled, it will enter the debugging state.
2	Operating status	<p>Energy storage system normal operation.</p> <ul style="list-style-type: none"> ● If the device operation status is manually shut down, it will enter the Standby state. ● If a fault alarm is detected, the system enters the fault state.
3	Fault status	<p>If fault is detected, energy storage system enters the fault state. Once fault is cleared, it transitions to the Standby state.</p>
4	Debugging status	<p>Energy storage system is in the debugging state and not operating normally.</p> <ul style="list-style-type: none"> ● If the Commissioning status is turned off, it will enter the Standby status. ● If a fault alarm is detected, the system enters the fault state.

3.4 Appearance Description

3.4.1 Appearance Introduction

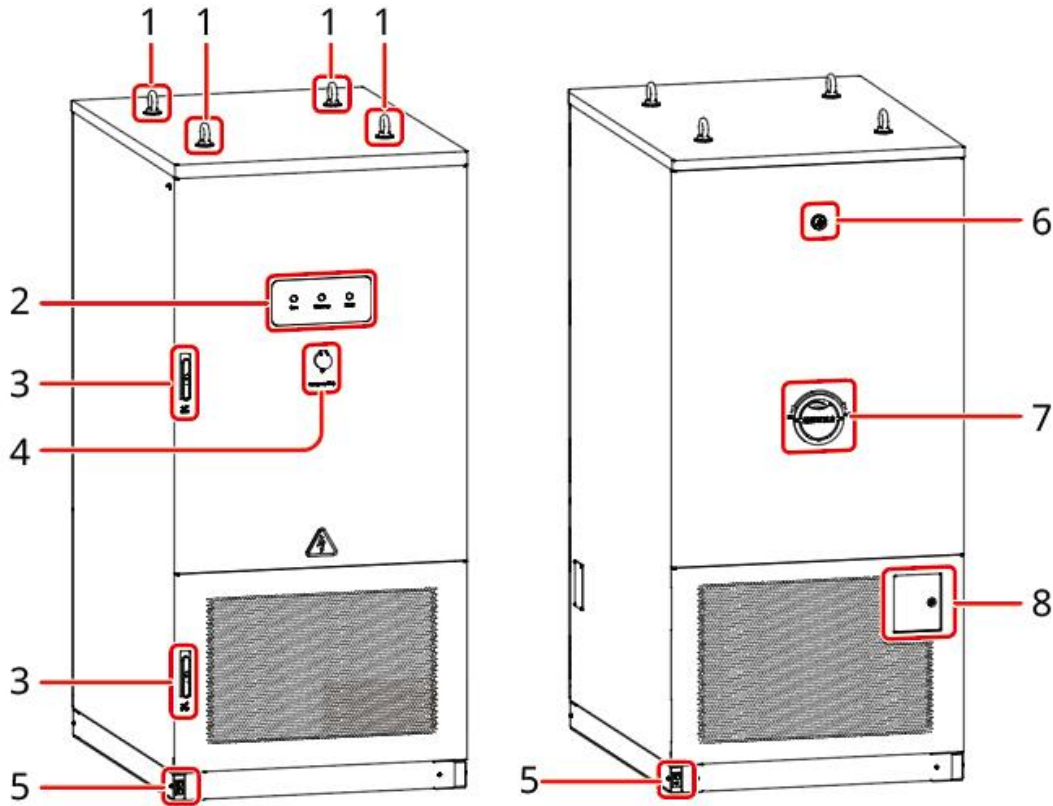

ESA10DSC0003

Serial number	Name	Function
1	Lifting eye	The lifting lug can be used for hoisting the energy storage system.
2	Indicator	Indicates the energy storage system operating status.
3	Door lock	Please use the key to unlock the cabinet door. Close and lock the cabinet door when no operation is required inside the equipment.
4	Emergency stop button	In case of an emergency, this button can be used to stop the system operation.
5	Grounding	Connect the energy storage system housing PE cable.
6	Pressure relief valve	When abnormal pressure rise occurs inside the system, it automatically opens to release excessive pressure, preventing risks such as system explosion.
7	Water firefighting connection	In case of thermal runaway and fire in the system, connect the fire hydrant here for extinguishing.

8	DC breaker Operation Cabin	Contains a DC breaker, capable of controlling the output of energy storage system DC power.
---	----------------------------	---

3.4.2 Size

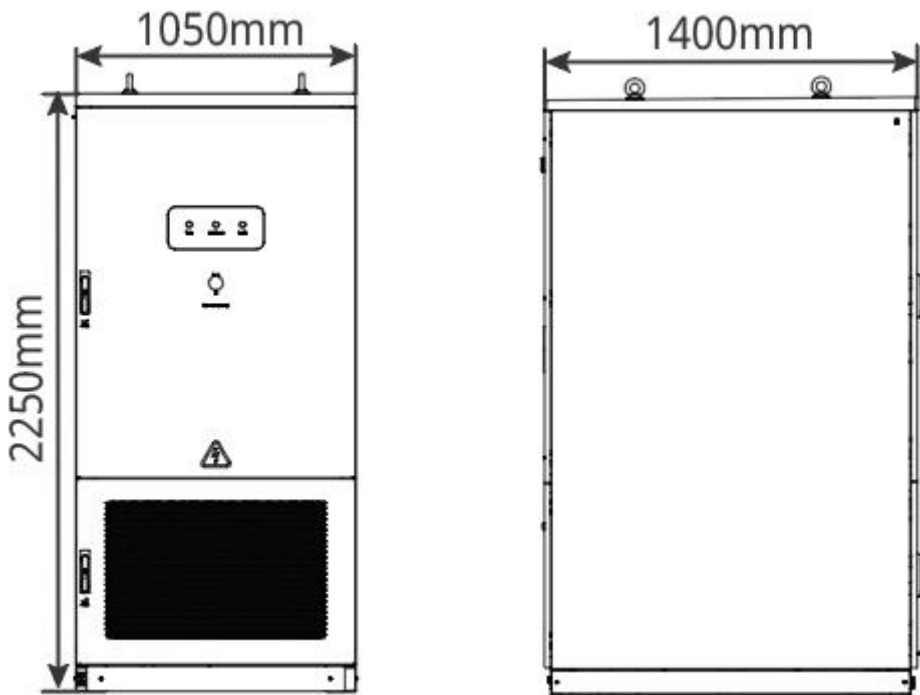

3.4.3 Component Introduction

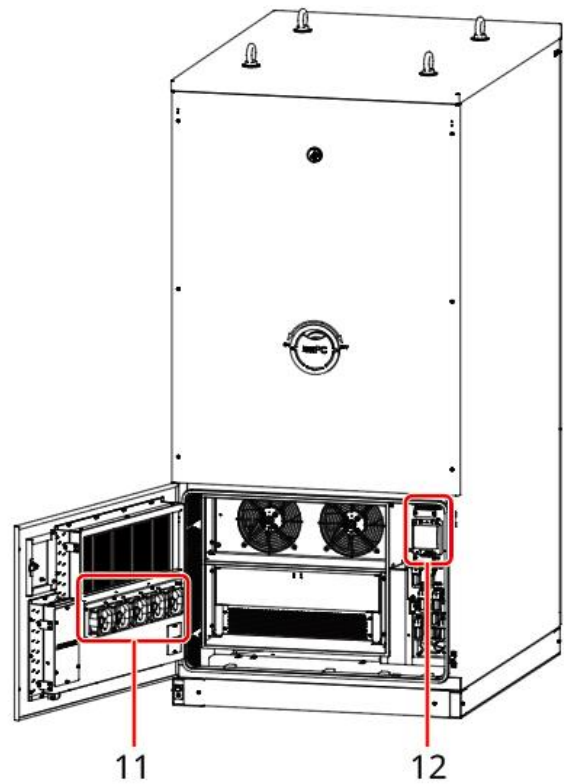
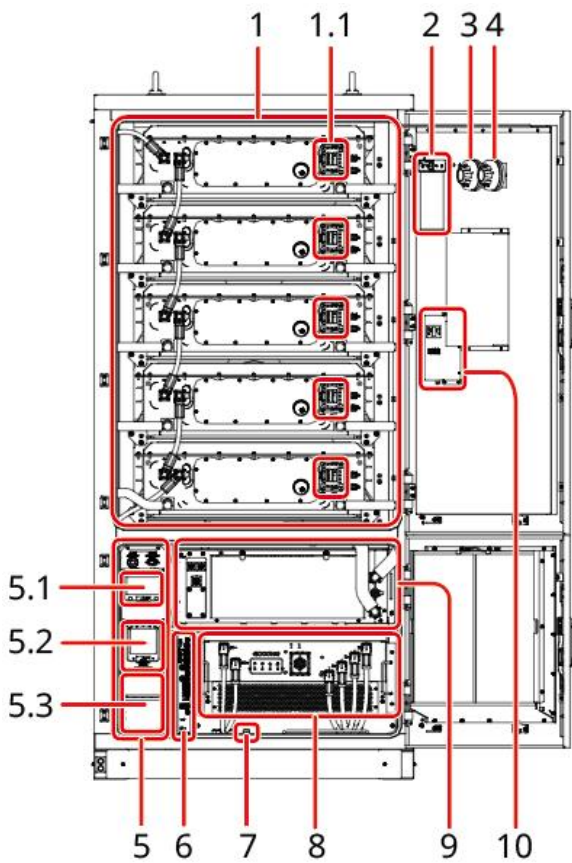

ESA10DSC0004

Serial number	Name	Function
1	Battery system	Storage and release of energy.
1.1	MSD switch	Manually disconnect or close the battery package high-voltage circuit.
2	Hot aerosol fire extinguishing device	Monitor fire signals inside the cabinet, implement fire suppression, and provide feedback to the local controller via DI signals.
3	Smoke detector	When a fire occurs in the energy storage system, the smoke detector detects smoke and outputs an electrical signal to the local controller, activating the audible and visual alarm, shutting down the system, and notifying personnel for timely handling. If the fire spreads after the smoke detector alarm is triggered, the thermal detector detects high temperatures and outputs an electrical signal to activate the fire suppression system, initiating fire extinguishment. Simultaneously, it sends a feedback signal to the local controller, shutting down the system and notifying personnel for timely intervention.
4	Temperature detector	

5	Distribution Module	Wiring area, including auxiliary power breaker and molded case breaker
5.1	Auxiliary Power Source	Manually disconnect or close the auxiliary power supply of the energy storage system.
5.2	Molded Case Circuit Breaker (MCCB)	Controls the connection and disconnection between the energy storage integrated cabinet and the Utility grid/load circuit.
5.3	AC wiring	Connect the on-grid AC cable.
6	Local Control Module	Responsible for energy management within the energy storage system and information exchange with the external environment.
7	Access control switch	Automatically pops out after opening to ensure energy storage system power off.
8	Power Conversion System (PCS)	Achieve electrical energy conversion between Utility grid and battery.
9	Liquid cooling unit	Used to maintain the battery system temperature within an appropriate range.
10	Dehumidifier	Used for dehumidifying inside the machine.
11	Fan	Used for cooling the PCS.
12	DC combiner box	The output of energy storage system DC power can be controlled.



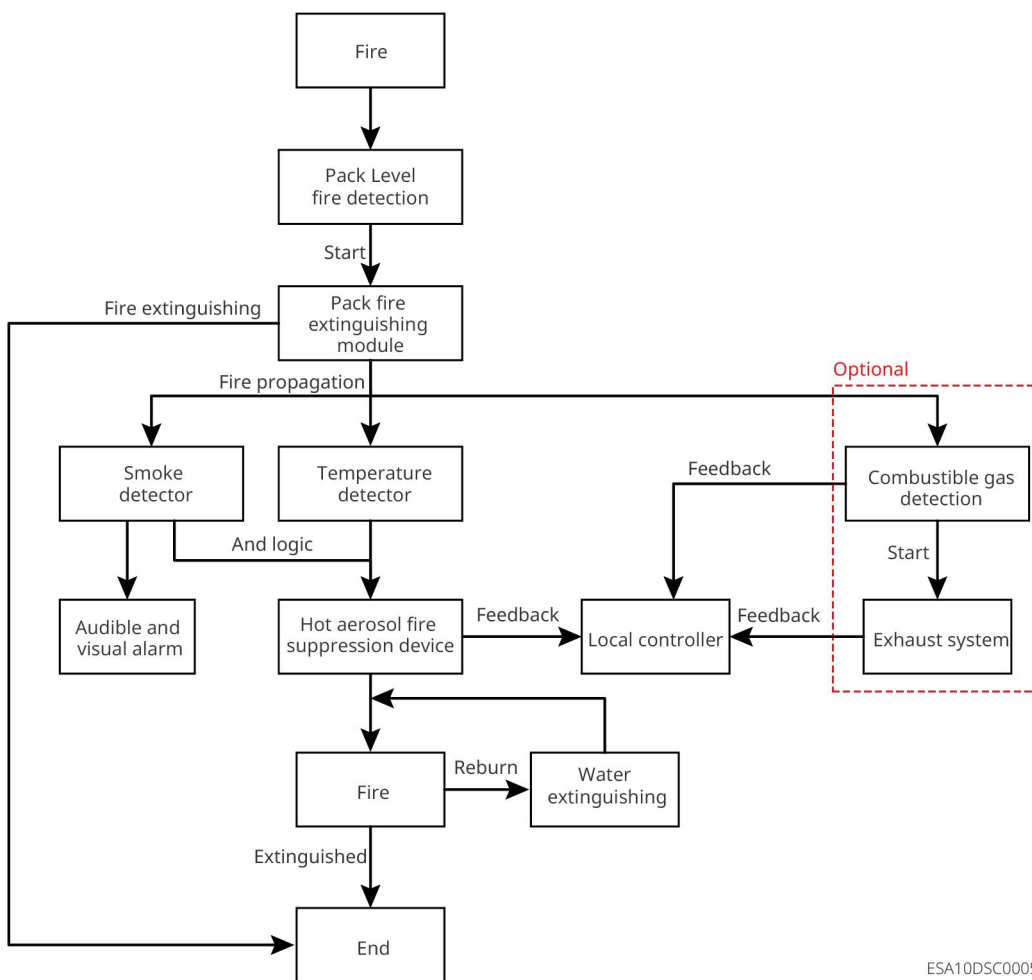

3.4.4 Fire Protection System

When a thermal runaway fire occurs in a battery cell, the Pack-level protection can quickly detect the fire through a thermal wire and activate the fire suppression module to implement primary fire extinguishing. If the pack fire spreads, the cluster-level protection can detect the fire through smoke sensors, triggering a smoke alarm. As the temperature rises rapidly, thermal sensors detect the fire and activate the fire suppression system to implement secondary fire extinguishing, while simultaneously outputting a feedback signal to the local controller to notify personnel for timely intervention. If the automatic fire suppression system fails to control the fire recurrence, emergency fire water can be connected for urgent handling to prevent severe consequences such as deflagration or fire outbreaks.



ESA10DSC0005

3.4.5 Indicators

Indicator	Description
  Run	White light steady on: Equipment is energized and in shutdown/self-test status.
	White light off: Device is not power on.
	Green light steady on: The device is in on-grid state.
 Warning	Constant On: The device has an alarm.
	Off: The equipment is operating normally without any alarms, or the equipment is not power on.
 Fault	Constant light with buzzer sound: Severe fault in the equipment.
	Off, no buzzing sound: The device is normal, or not power on.

3.4.6 Nameplate

The nameplate is for reference only. Please refer to the actual product.

GOODWE Product: **Energy Storage System**
 GW125/261-ESA-LCN-G10 IFp72/174/207((S2S1P)5S)/-20+50/95

Battery	Nominal Energy:	261.25kWh
	Operating Voltage Range:	676-936Vd.c., LiFePO ₄
	Nominal Voltage:	832Vd.c.
	Cell Capacity:	314Ah
	Max. Continuous Charge/Discharge Current:	188/188Ad.c.
	Nominal Charge/Discharge Current:	157Ad.c.
	Max. Short-circuit Current@Time:	10kA@2ms
	Charging Temperature Range:	0-+55°C
	Discharging Temperature Range:	-20-+55°C
	Usable Extinguishing Agent:	CO ₂ , Novac1230, FM-200
On-grid	Crucial Material:	LiFePO ₄ , C, C ₂ H ₄ O ₂ , C ₂ H ₂ O ₂ , Cu, Al, C ₂ H ₂ O ₂ , C ₂ H ₂ O ₂ , LiPF ₆ , (C ₂ H ₅) ₃ N
	Nominal Output Frequency:	50/60Hz
	Nominal Output Voltage:	380/400Va.c., 3L/N/PE
	Nominal Output Power:	125kW
	Nominal Output Apparent Power to Grid:	125kVA
	Nominal Input Apparent Power from Grid:	125kVA
	Max. AC Current Output to Grid:	198.5Aa.c.
	Max. AC Current from Grid:	198.5Aa.c.
Off-grid	Max. Output Apparent Power to Grid:	137.5kVA@400V, 130.6kVA@380V
	Max. Input Apparent Power from Grid:	137.5kVA@400V, 130.6kVA@380V
	Nominal Apparent Power:	125kVA
	Nominal Output Frequency:	50/60Hz
	Nominal Output Voltage:	380/400Va.c., 3L/N/PE
	Max. AC Output Current:	198.5Aa.c.
Max. Output Apparent Power to Grid :		137.5kVA@400V, 130.6kVA@380V

Power Factor: -1.0.8lag to 0.8lead, Operating Temperature Range: -20-+55°C,
 Protective Class: I, Topology: Non-Isolated, Weight: 2580kg,
 Ingress Protection: IP54, Overvoltage Category: DCB / ACBII

S/N:
 Code:

GoodWe Technologies Co., Ltd. E-mail: service@goodwe.com
 No.90 Zijin Rd., New District, Suzhou, 215011, China Made in China

Trademark and Product Model

Technical Parameters

Security markings, serial number and company information







4 Check and Storage

4.1 Check before Receiving

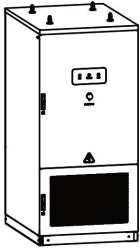
Before signing for the product, please carefully inspect the following:

1. Check the outer packaging for any damage, such as deformation, punctures, cracks, or other signs that may indicate potential harm to the equipment inside the box. If damage is found, do not open the packaging and contact your distributor.
2. Check if the energy storage system model is correct. If it does not match, do not open the package and contact your distributor.
3. Check whether the deliverable type and quantity are correct and whether there is any damage to the appearance. If damaged, please contact your distributor.

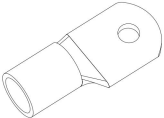
4.2 Deliverables

component	Description	Component	Instructions
	energy storage system x1		Expansion screw x4
	fireproofing mud x3		antenna x 1 (WiFi)
	PIN terminal x 10		AC OT wiring terminalx5
	MSD switch x5		Product Information x 1

4.3 Storage

If energy storage system is not put into use immediately, please store it according to the following requirements:

1. Ensure the storage environment is clean, with an appropriate temperature range and no

condensation.

2. After long-term storage, it must be inspected and confirmed by professionals before it can be used again.
3. The equipment shall be packed in packaging boxes, and the packaging boxes shall be sealed after placing desiccants inside.
4. If the Installation is not performed within 3 days after unpacking, it is recommended to store the equipment in the packaging box.
5. If it is expected that the battery module will be stored for more than 30 days, the SOC should be adjusted to 30%~45% and a full charge Discharge must be performed every three months.
6. Storage Temperature Storage range: up to one year at 0~35°C, and up to one month at -20~45°C.
7. Humidity Range: 10~95% non-condensing. Do not Installation when moisture condensation occurs at the interface.
8. Equipment should be stored in a shaded area, avoiding direct sunlight.
9. Storage should be kept away from flammable, explosive, and corrosive materials.
10. Ensure that energy storage system is not damaged during transportation and storage.
11. Do not expose battery to fire, as there is a risk of explosion.
12. When the ambient temperature is too high, battery system poses a risk of fire.

5 Installation

5.1 Installation Requirements

Installation Environment Requirements

1. Equipment must not be operated in flammable, explosive, or corrosive environments.
2. The ambient temperature of the equipment Installation should be within the appropriate range.
3. Keep out of reach of children and avoid placing in easily accessible locations.
4. During operation, the enclosure temperature of energy storage system may exceed 60°C. Do not touch the enclosure before it cools down to prevent burns.
5. It is recommended to place the equipment in a shaded Installation Location to avoid exposure to sunlight, rain, snow, and other Installation conditions. If necessary, a sunshade can be installed.
6. The space for Installation must meet the ventilation and heat dissipation requirements of the equipment as well as the operational space requirements.
7. The Installation environment must meet the equipment's Ingress Protection Rating. energy storage system, battery, and smart dongle satisfy indoor and outdoor Installation; the electric meter meets indoor Installation.
8. The height of the equipment installation should facilitate operation and maintenance, ensuring that the equipment indicator and all labels are easily visible, and the wiring terminal is easy to operate.
9. The installation altitude is below max operating altitude.
10. Before installing outdoor equipment in salt affected area, consult the equipment manufacturer. salt affected area primarily refers to areas within 500 meters of the coastline. The affected zone is related to factors such as sea breeze, precipitation, and terrain.
11. Do not install energy storage system installation in noise-sensitive areas (such as residential areas, offices, schools, etc.), as it may cause complaints from residents. If it is necessary to Installation in the above areas, the installation location should be at least 40m away from the noise-sensitive area.
12. If the equipment installation is installed in public areas other than work and living spaces (such as parking lots, stations, factory buildings, etc.), install protective barriers around the equipment and erect safety warning signs to isolate it. Unauthorized personnel should be prohibited from approaching energy storage system to prevent personal injury or property damage caused by accidental contact or other actions by non-professionals during equipment operation.
13. Keep away from strong magnetic fields to avoid electromagnetic interference. If there are radio stations or wireless communication devices below 30MHz near the Installation Location, follow the requirements below to Installation the equipment:
 - Energy storage system: Add ferrite cores with multiple turns on the DC input or AC output lines of the energy storage system, or incorporate a low-pass EMI Filter; Alternatively, maintain a distance of over 30 meters between the energy storage system and any wireless electromagnetic interference devices.

- Other equipment: The distance between the equipment and the wireless electromagnetic interference device exceeds 30m.

Installation Environment Requirements



ESA10INT0008

Installation Space Requirements

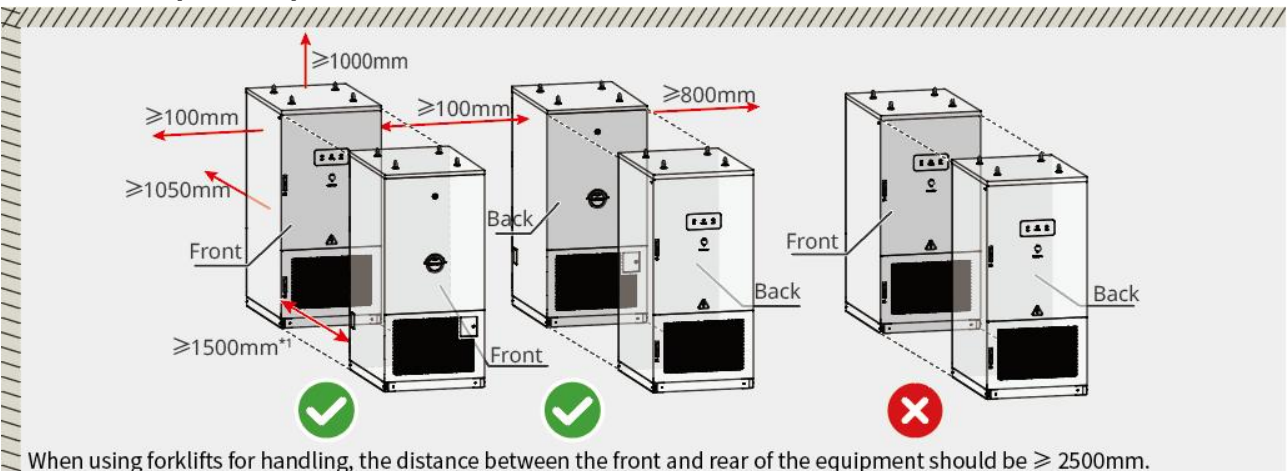

When using forklifts for handling, the distance between the front and rear of the equipment should be $\geq 2500\text{mm}$.

ESA10INT0009

Installation angle requirement

Ensure the equipment is placed horizontally Installation and not tilted, laid sideways, or inverted.

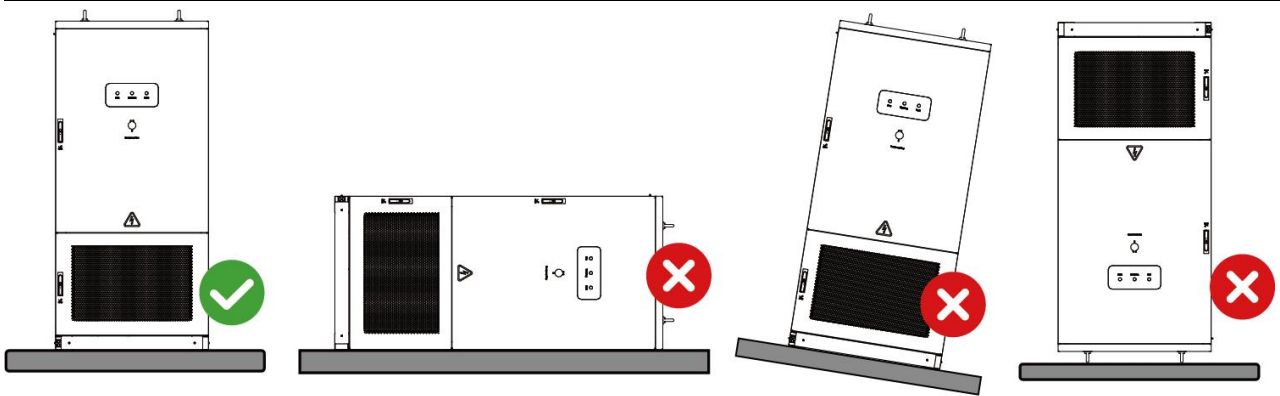

ESA10DSC0006

Installation Foundation Requirements

- The equipment must be installed on a concrete or other non-combustible surface base.
- Before installation, ensure the base is level, sturdy, flat, dry, and has sufficient load-bearing capacity. Avoid any depressions or tilting.
- The base shall reserve cable trenches or outlet holes for convenient equipment wiring.
- The equipment adopts bottom cable entry, and the cable trench must be designed to be dust proof and rodent-proof to prevent foreign objects from entering.
- Cable trenches must be designed with waterproof and moisture-proof measures to prevent cable aging and short circuits, which could affect the normal operation of equipment.
- Due to the thick equipment cables, the cable trench must be designed with sufficient space reserved for the cables to ensure smooth and wear-free connections.

Foundation dimension requirements:

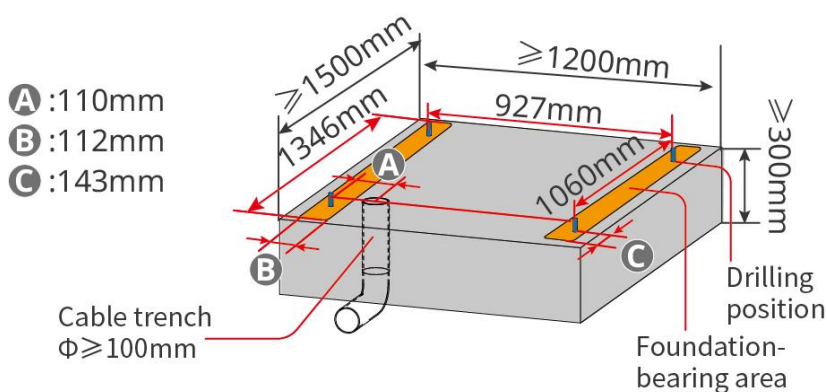

ESA10INT0010

Installation Tool Requirements

When installation, it is recommended to use the following installation tools. If necessary, other auxiliary tools can be used on-site.

Tool Type	Instructions	Tool type	Description
-----------	--------------	-----------	-------------

	Goggle		Safety shoes
	Safety gloves		Dust mask
	Socket Wrench		Diagonal plier
	Wire stripper		Hammer drill
	Hot air gun		AC terminal hydraulic pliers
	PIN terminal crimping tool		Tape
	Marker pen		Level bar
	Heat shrink tubing		Rubber hammer
	Cable tie		Vacuum cleaner
	Torque wrench		Multimeter

5.2 Energy Storage System Installation

5.2.1 Moving Energy Storage System

CAUTION

- During transportation, handling, and installation operations, it is necessary to comply with the laws, regulations, and relevant standards of the respective country or region.
- To ensure that Protection equipment is not damaged during transportation, please ensure that the transport personnel are professionally trained. Record the operational steps during transportation and maintain the balance of the equipment to prevent it from falling.
- Before installation, it is necessary to transport energy storage system to the installation location. To prevent personal injury or equipment damage during transportation, please notice the following matters:
 1. Please equip the corresponding personnel and tools according to the Weight of the equipment to prevent the equipment from exceeding the Weight range that can be manually handled, thereby causing injury to personnel.
 2. Please ensure the equipment is kept balanced during handling to avoid falling.
 3. During Equipment Handling, ensure the cabinet door is securely locked.

NOTICE

- Energy storage system can be transported to the installation location by hoisting or forklift.
- When lifting and moving equipment, use flexible slings or straps, with a single strap load-bearing capacity of $\geq 5t$.
- When using forklift handling equipment, the load-bearing capacity of forklift must be $\geq 5t$.
- Antenna, the door panel surface sticker is a installation transportation vulnerable position, please caution.

Hoisting and handling equipment (optional)

Step 1: Use a lifting sling with hooks or U-hooks to perform the overhead lifting operation on the energy storage system.

Step 2: Use lifting equipment to hoist and transport the energy storage system.

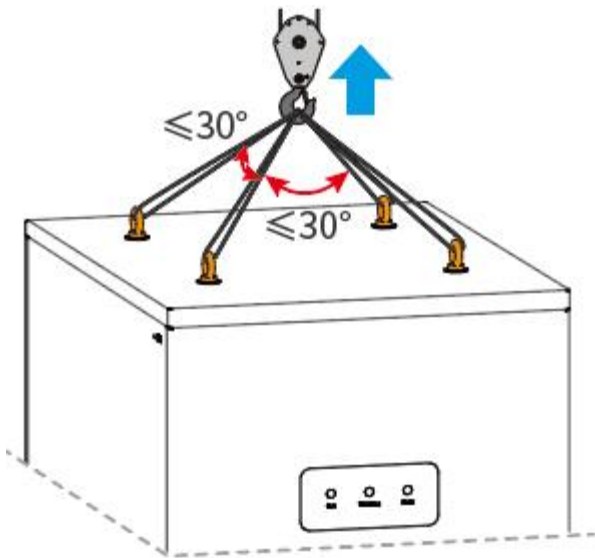

ESA10INT0011

Forklift Handling Equipment (Optional)

Step 1: Remove the front and rear baffles of the energy storage system.

Step 2: Use forklift to transport energy storage system, ensuring the equipment's center of gravity is positioned at the center of the forklift foot.

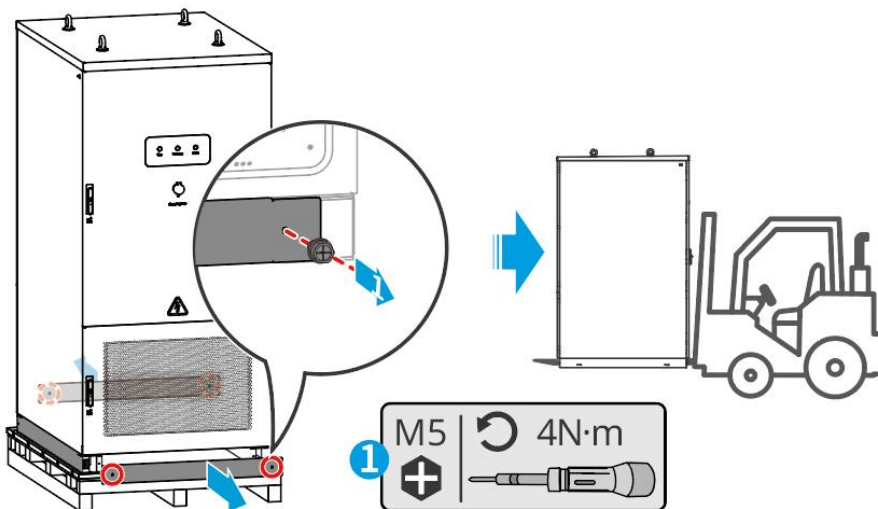

ESA10INT0012

5.2.1 Installing Energy Storage System

NOTICE

- Ensure the energy storage system is vertically flush with the ground and free from tipping risks.
- Ensure the energy storage system installation is securely fastened to prevent tipping and causing injury to personnel.
- Antenna, the surface of the door panel is installation, which is prone to damage during transportation. Please caution.

Step 1: Use a marker pen to mark the drilling positions on the level ground.

Step 2: Use an 18mm diameter hammer drill to drill holes, ensuring a depth of approximately 70mm (±2mm) and installation Expansion bolt.

Step 3: Move the energy storage system onto the foundation.

Step 4: Install perimeter baffles around dismantle.

Step 5: Secure the energy storage system to the foundation.

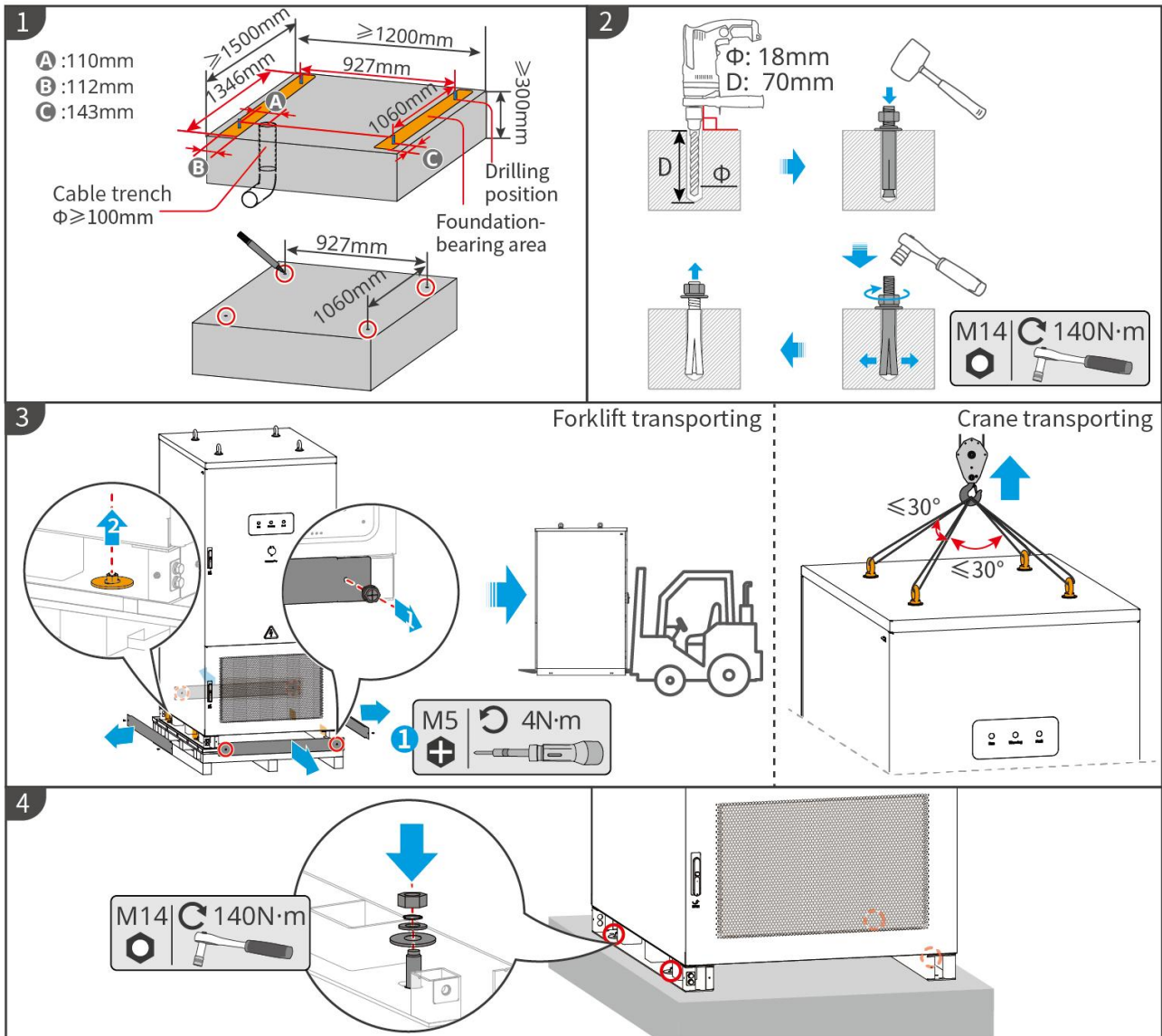

ESA10INT0003

6 Electrical Connection

6.1 Safety Precautions

DANGER

- All operations during the electrical connection process, as well as the specifications of cables and components used, must comply with local laws and regulations.
- Before making electrical cable connections, ensure all upstream switch of the energy storage

system are disconnected.

- Before performing electrical connections, disconnect the energy storage system's AC switch and battery switch to ensure the equipment is power off. Live working is strictly prohibited, as it may lead to electric shock and other danger.
- Cables of the same type should be bundled together and arranged separately from different types of cables. Intertwining or cross-arrangement is strictly prohibited.
- If the cable is subjected to excessive tension, it may result in poor connections. When wiring, leave a certain length of cable slack before connecting to the energy storage system terminal port.
- When crimp wiring terminal, ensure that the conductor part of the cable is in full contact with the wiring terminal. Do not crimp the cable insulation together with the wiring terminal.
- Otherwise, it may cause the equipment to fail to operate, or after operation, unreliable connections may lead to overheating, resulting in damage to the energy storage system terminal row and other conditions.
- Cables used in high-temperature environments may experience insulation aging or damage. The distance between cables and heat-generating components or the periphery of heat source areas should be at least 30mm.

NOTICE

- When performing electrical connections, wear safety shoes, protective gloves, insulated gloves, and other PPE as required.
- Only qualified personnel are permitted to perform electrical connection operations.
- The cable colors in the diagrams of this document are for reference only. The actual cable specifications must comply with local regulatory requirements.
- It is recommended to use copper wires for AC connection lines.

No.	cable	Type	Specification
1	Grounding cable	Hot-dip galvanized flat steel	Must comply with local AC electrical installation grounding design specifications.
2	AC line (GRID)	Copper-core stranded cable	70mm ²
3	RS485 cable	Outdoor Shielded Twisted Pair	Conductor cross-sectional area: 0.5mm ²
4	LAN cable	CAT 5E outdoor shielded network cable with RJ45 RJ45 connector	

6.2 Connecting the PE Cable

WARNING

- Before operating the equipment, ensure that the system is reliably grounded and all relevant protective measures are in place. Otherwise, there may be a risk of electric shock.
- To improve the corrosion resistance of the terminal, it is recommended to secure it with an M10 bolt at the lower left corner of the cabinet Grounding point. After completing the connection of the installation, apply silica gel or paint to the exterior of the Grounding terminal for protection.
- Support flat steel connection Protection grounding cable, please prepare flat steel by yourself.

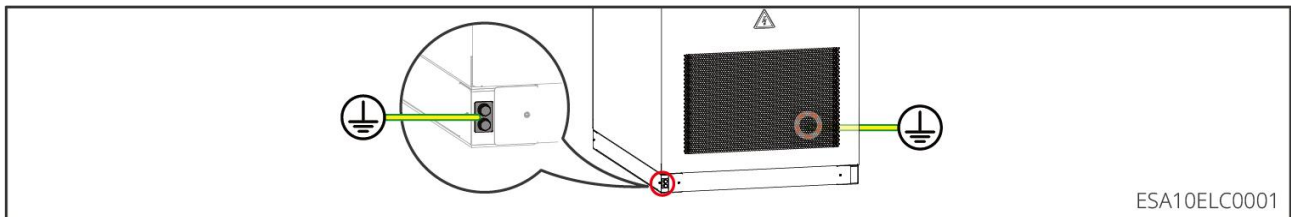

6.3 Wiring Preparation

Cabinet door operation

NOTICE

Please keep the key properly after use.

Open the front cabinet door

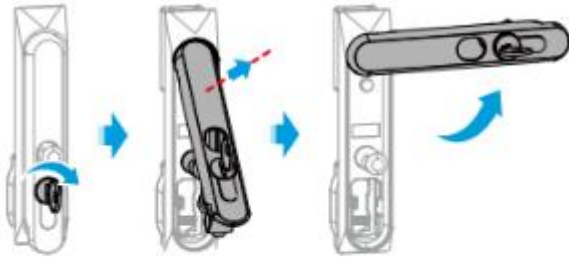

Close the front cabinet door

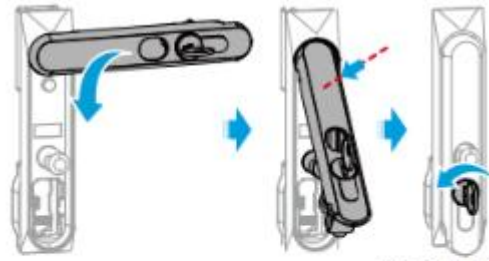

ESA10INT0004

Open the operation cabin door of the DC circuit breaker



Close the operation cabin door of the DC circuit breaker

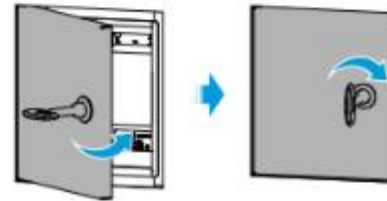

ESA10INT0005

Open the switch door

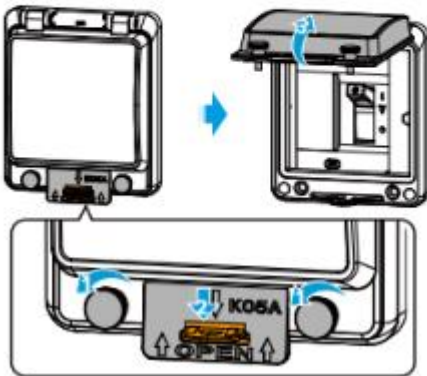

Close the switch door



ESA10INT0006

Wiring position and wire guard operation

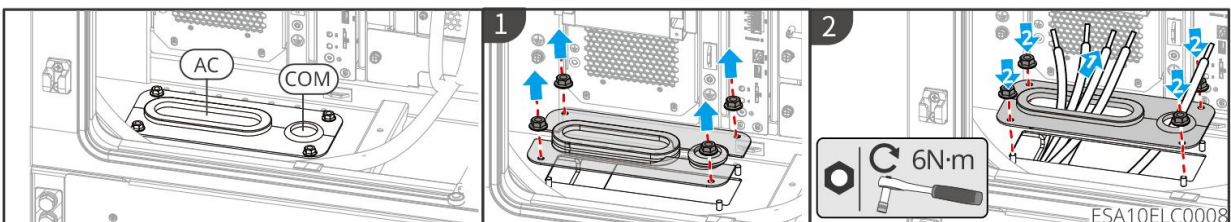

6.4 Connect the AC Output Cable

DANGER

After the energy storage system power on, the AC wiring port becomes live. For maintenance, ensure to disconnect the upstream and downstream breaker or energy storage system power off, otherwise it may cause electric shock.

WARNING

- During wiring, ensure that the AC wires fully match the "L1", "L2", "L3", and "N" terminals of the AC terminal. Incorrect cable connections may result in equipment damage.
- Ensure the conductor is fully inserted into the terminal terminal hole with no exposed parts.
- Ensure the cable connections are securely fastened; otherwise, overheating of the terminal terminals may occur during equipment operation, leading to device damage.
- Ensure all switches of the equipment are disconnected.

NOTICE

After completing the AC cable connection, please close the front baffle of the wiring area and clean up any construction debris left in the maintenance cavity.

Step 1: Prepare the required cables and OT terminal, then perform crimp to fabricate the AC output cable.

Step 2: Connect the AC cable to the machine.

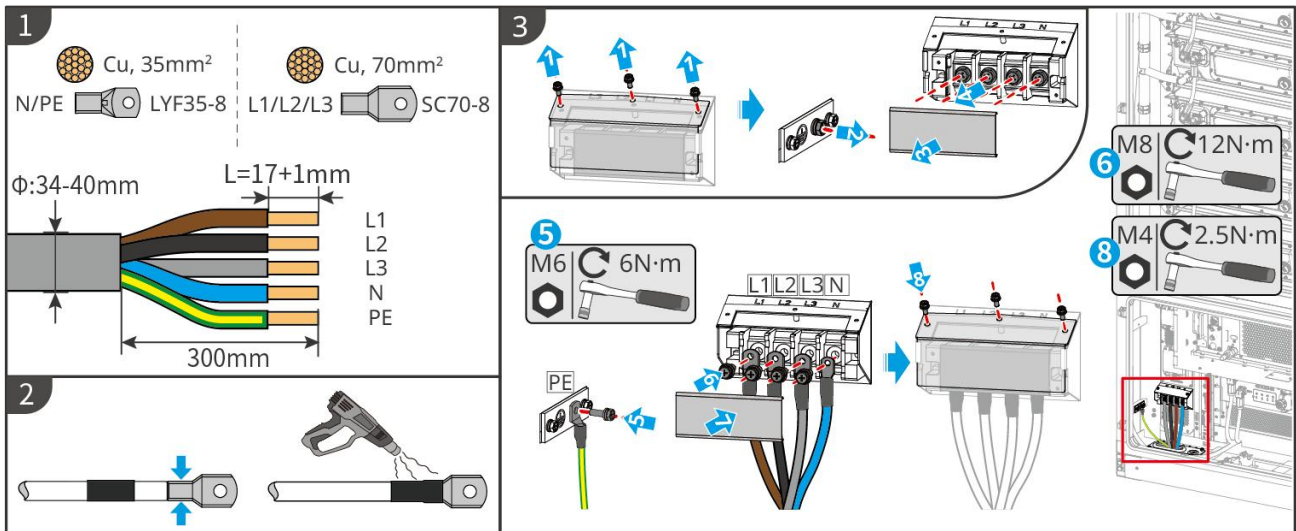

6.5 Connection Communication Cable

NOTICE

When connecting Communication cable, the cable routing path should avoid interference sources such as power cable to prevent affecting signal reception.

6.5.1 Communication Port Introduction

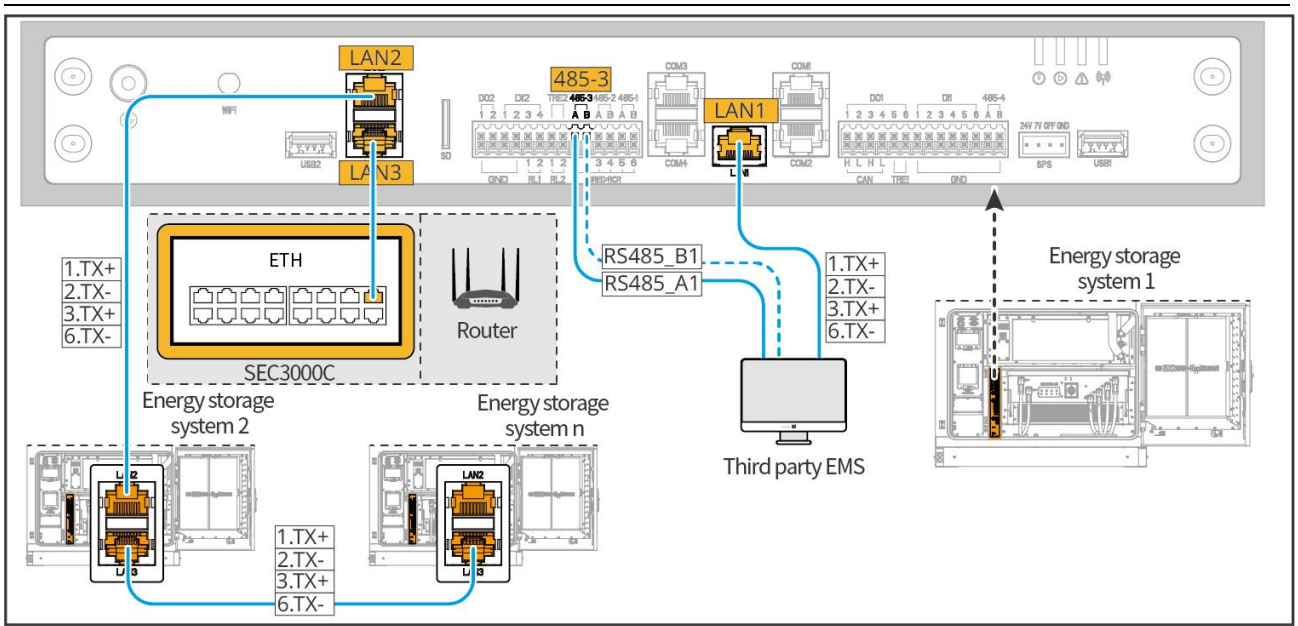

ESA10ELC009

Connect SEC3000C:

Method 1:

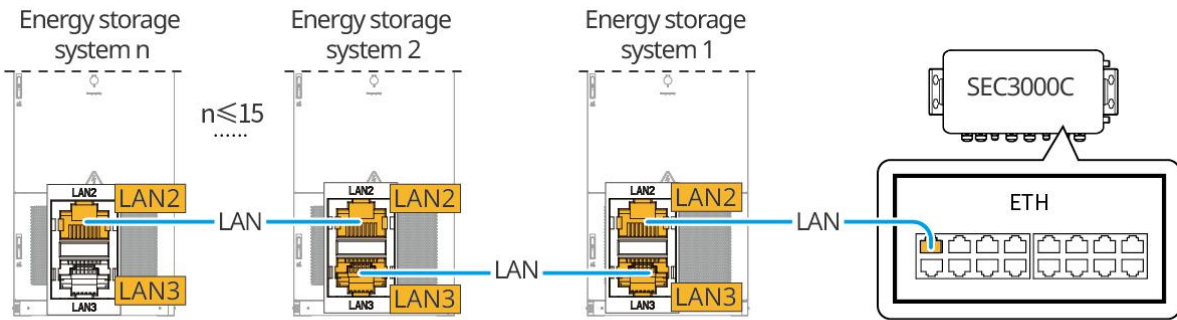

ESA10NET005

Method 2:

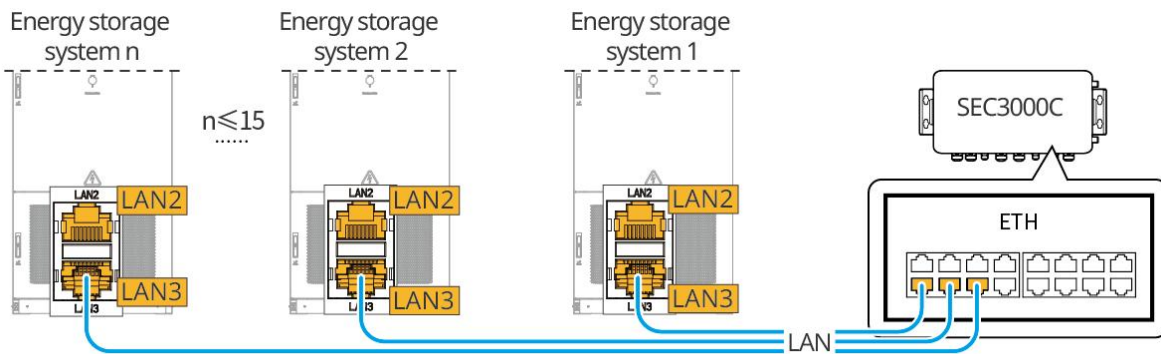

ESA10NET006

Connecting to a third-party EMS:

Method 1:

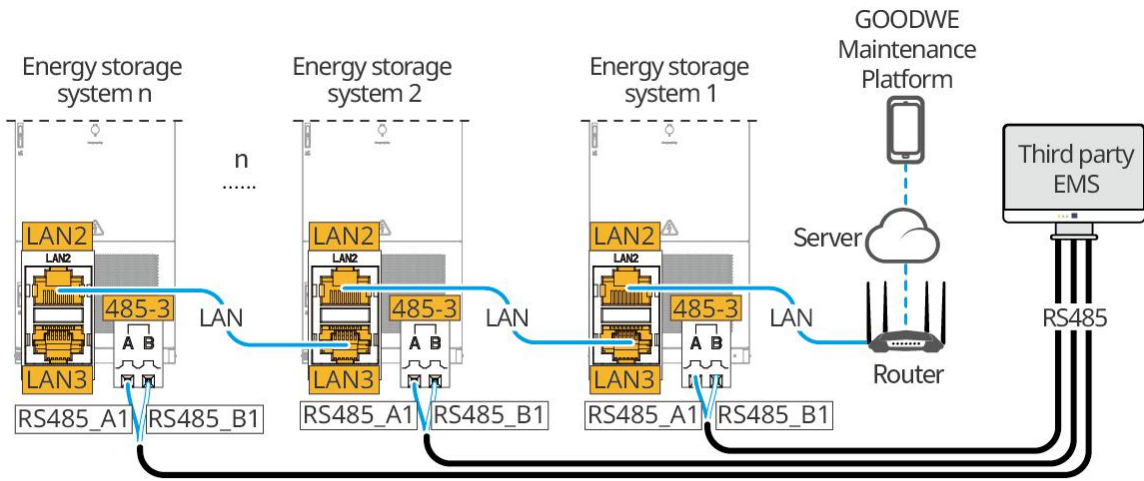

ESA10NET0007

Method 2:

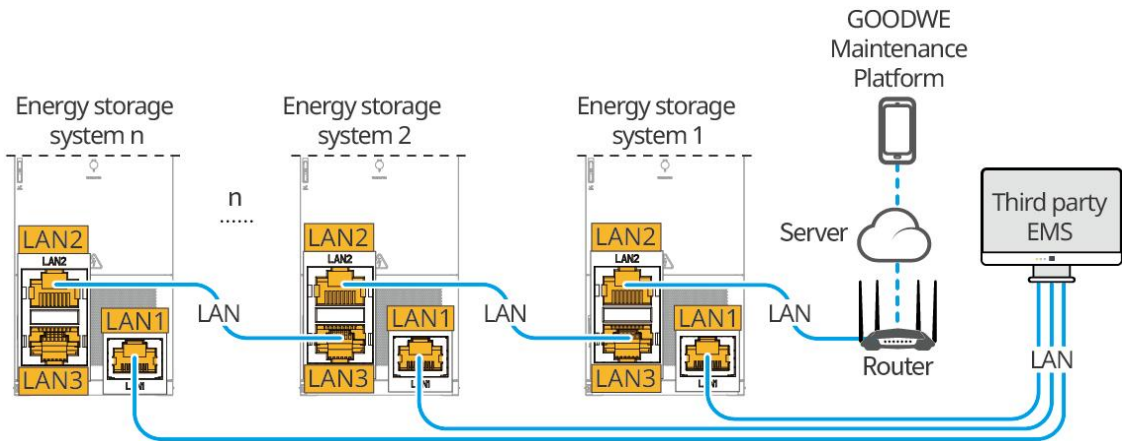

ESA10NET0008

6.5.2 Antenna Installing

NOTICE

The energy storage system local control module and the WiFi Communication Port at the top of the system cabinet have been pre-connected with an Communication cable cable. During use, only installation antenna is required.

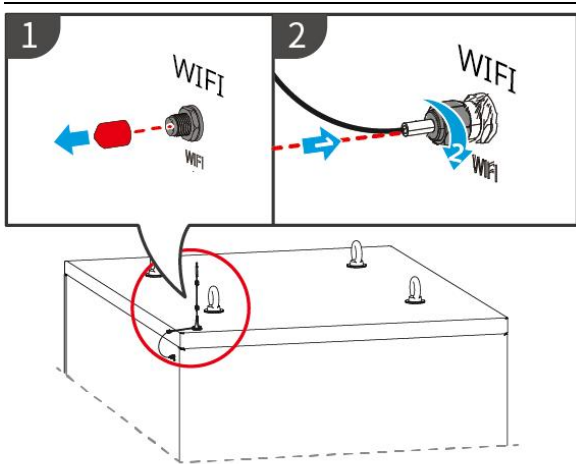

ESA10ELC0007

6.6 MSD Switch Installation

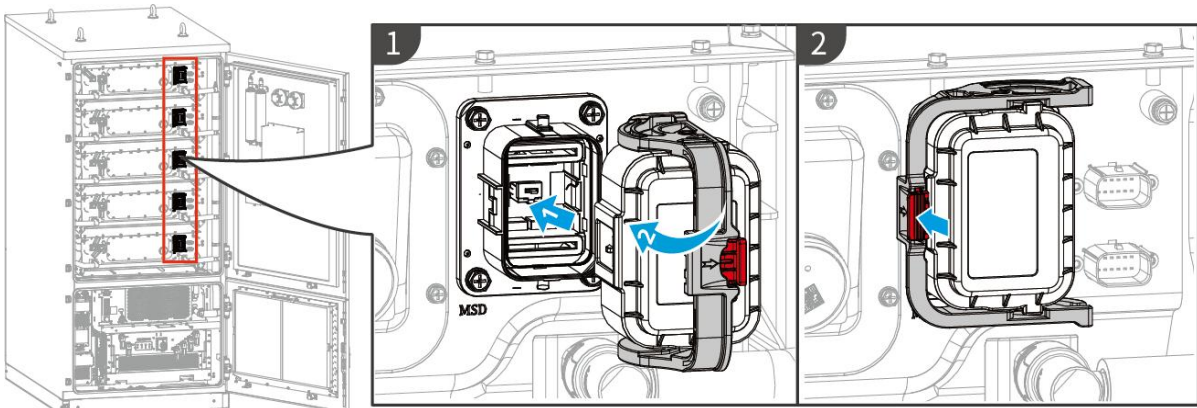

ESA10ELC0005

6.7 Operation after Wiring

Close the side and front baffles.

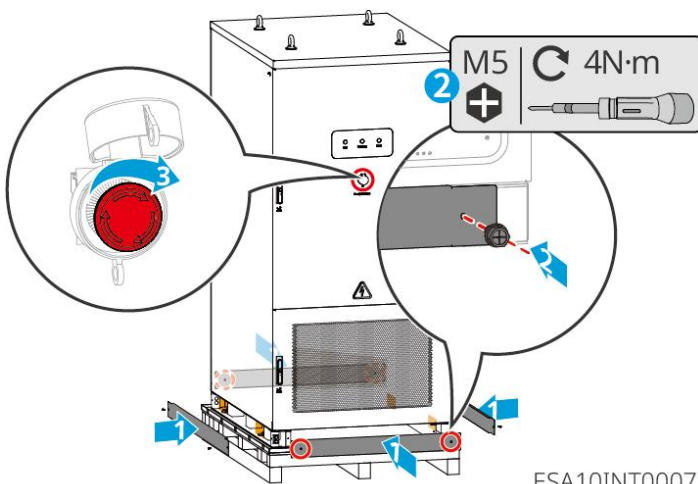

ESA10INT0007

7 Equipment Commissioning

7.1 Check Items before Power On

No.	Inspection items
1	The energy storage system is securely installed, the installation Location facilitates operation and maintenance, the installation space allows for ventilation and heat dissipation, and the installation environment is clean and tidy.
2	The PE cable, DC input line, AC output line, and Communication cable are correctly and securely connected.
3	Cable bundling complies with routing requirements, is reasonably distributed, and free from damage.
4	Unused port has been sealed.
5	The energy storage system and Frequency of the on-grid access point comply with the on-grid requirements.

7.2 Power On

Step 1: Close QF2 (DC breaker).

Step 2: Close QF1 (AC molded case circuit breaker).

Step 3: Close Q2 (DC auxiliary switch).

Step 4: Close Q1 (AC auxiliary switch).

Step 5: Close the front door. After the front door indicator changes from white to green, the system completes on-grid.

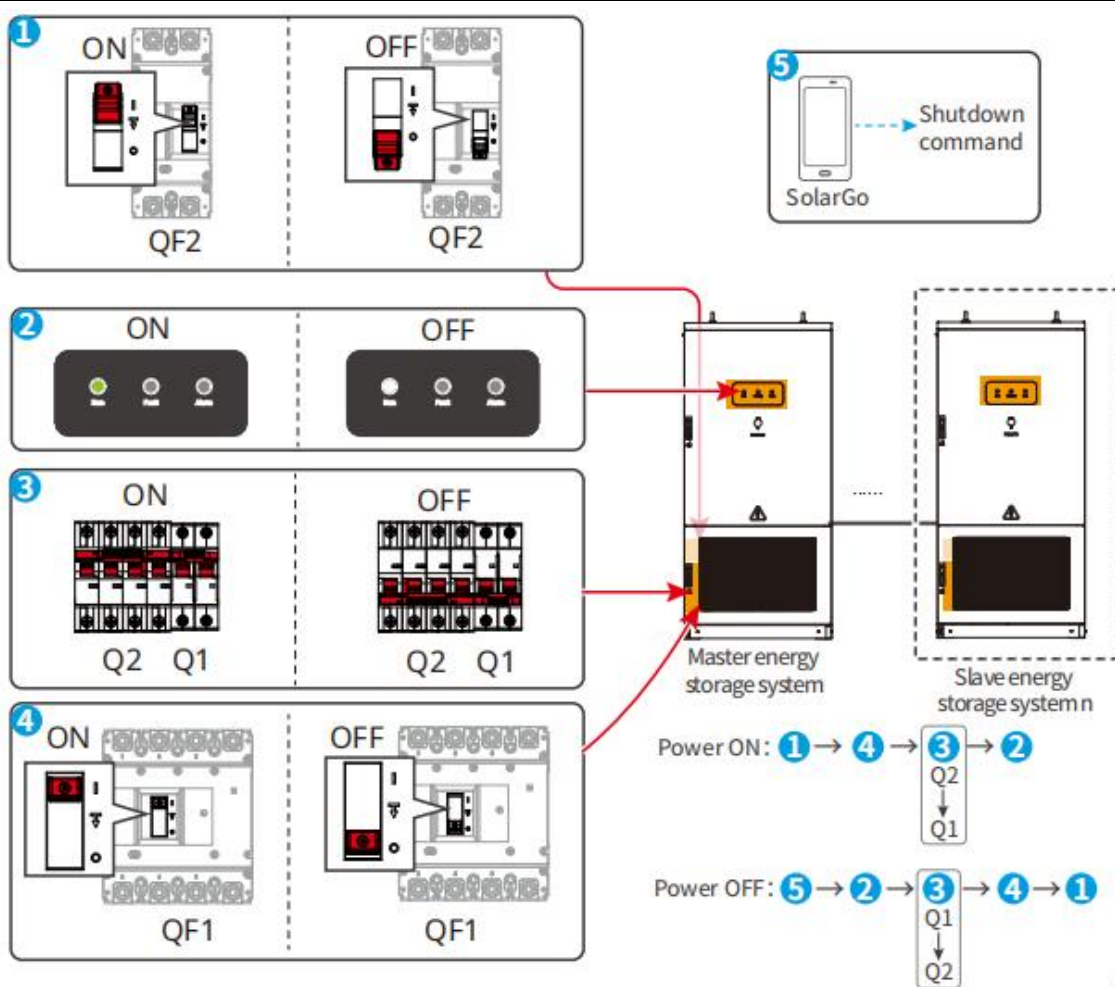

8 System Commissioning

8.1 Set Inverter Parameters via Solargo

The SolarGo App is a mobile application software that can communicate with Inverter via Bluetooth modules and WiFi modules. The following are its common features:

1. View the operating data, software version, alarm information, etc. of Inverter.
2. Set the Utility grid parameters, Communication parameters, etc. for Inverter.
3. Maintenance equipment.

For detailed functions, please refer to the "SolarGo App User Manual". The user manual can be obtained from the official website or by scanning the QR code below.



SolarGo Download



SolarGo App User Manual

8.2 Set Inverter Parameters via SEC3000C Embedded Web

The SEC3000C smart energy controller is a dedicated device for the monitoring and management platform of photovoltaic (PV) power generation systems. It can be used to collect data from equipment in PV systems, such as grid-tied PV inverter, hybrid inverter, meters, etc., store logs, and transmit the data to the monitoring and management platform, enabling centralized monitoring, operation, and maintenance of the PV system.

For detailed functions, please refer to the "SEC3000C User Manual." The manual can be downloaded from the official website or by scanning the QR code below.



9 Power Plant Monitoring via SEMS

SEMS is a monitoring platform that can communicate with devices via WiFi, LAN, or 4G. The following are the common functions of SMES:

1. Managing organizations or user information, etc.
2. Add, monitor power station information, etc.
3. Maintenance equipment.

For detailed functions, please refer to the "SMES User Manual." The manual can be obtained from the

official website or by scanning the QR code below.



10 Maintenance

10.1 Power Off Energy Storage System

DANGER

- When performing operation and maintenance on the energy storage system, ensure the energy storage system is power off. Operating live equipment may cause damage to the energy storage system or result in electric shock danger.
- After energy storage system power off, the internal components require a certain amount of time to Discharge. Please wait according to the label time requirements until the equipment is fully discharge.

CAUTION

If the energy storage system remains idle or inactive for an extended period, it must be powered down following the shutdown sequence specified in the user manual to prevent battery over-discharge.

Step 1: Issue a shutdown command to energy storage system via SolarGo.

Step 2: Observe that the RUN indicator white light is steadily illuminated.

Step 3: Disconnect Q1 (AC auxiliary switch).

Step 4: Disconnect Q2 (DC auxiliary switch).

Step 5: Disconnect QF1 (AC molded case circuit breaker).

Step 6: Disconnect QF2 (DC breaker).

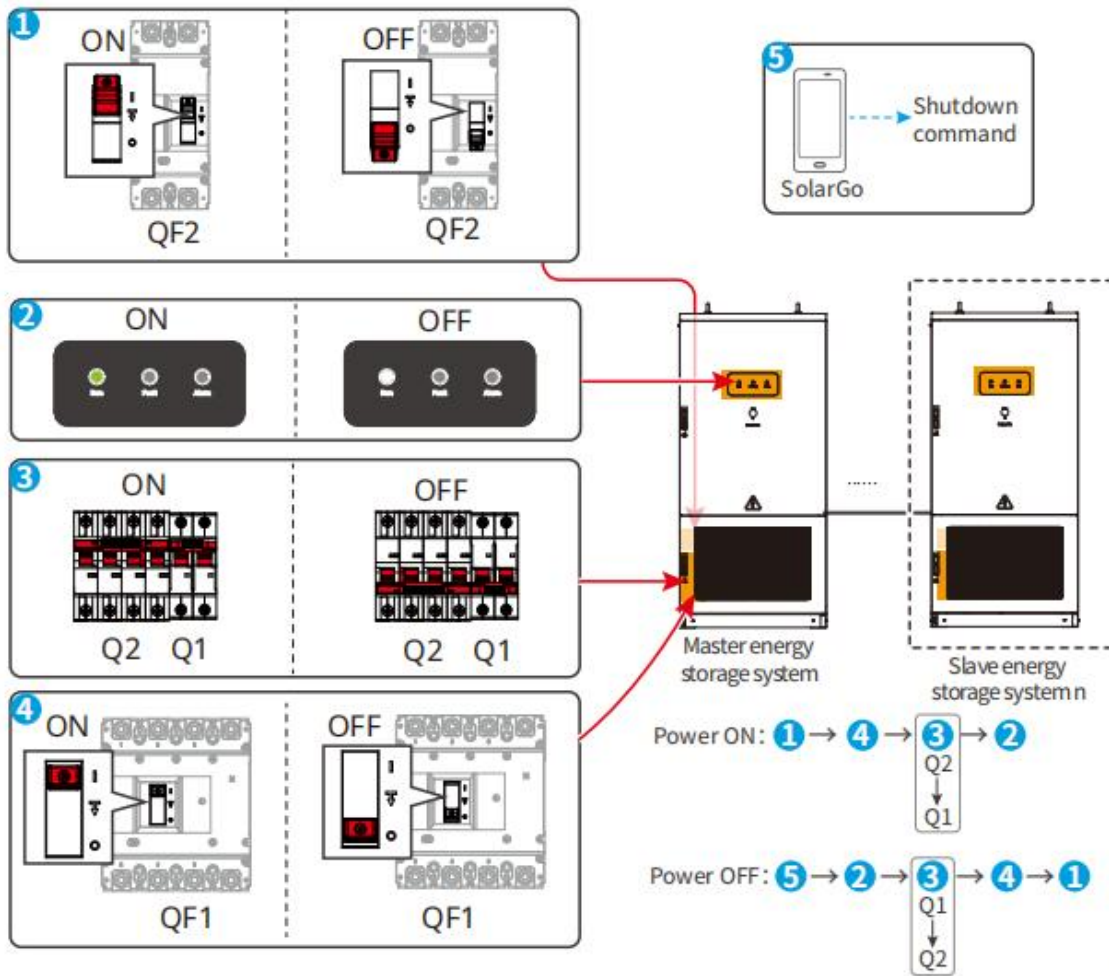

ESA10PWR0001

10.2 Removing Energy Storage System

WARNING

- Ensure the energy storage system is power off.
- When operating energy storage system, please wear personal protective equipment.

Step 1: Open the cabinet door.

Step 2: Disconnect all electrical connections of the energy storage system, including: MSD switch, DC cables, AC cables, Communication cable, and PE cable.

Step 3: Hoisting or forklift transportation, removing the energy storage system from the foundation.

Step 4: Store the energy storage system properly. If the energy storage system is to be reused in the future, ensure that the storage conditions meet the required specifications.

10.3 Disposing of Energy Storage System

When energy storage system can no longer be used and needs to be scrapped, it must be disposed of in accordance with the electrical waste disposal requirements of the country/region where energy

storage system is located. energy storage system must not be treated as household waste.

10.4 Troubleshooting

Please follow the troubleshooting steps below for fault. If the troubleshooting methods do not resolve the issue, please contact the after-sales service center.

When contacting the after-sales service center, please collect the following information to facilitate a quick resolution.

1. energy storage system information, such as: serial number, software version, device installation time, fault occurrence time, fault occurrence Frequency, etc.
2. Equipment installation environment, such as weather conditions, etc. The installation environment recommendation can provide photos, videos, and other files to assist in problem analysis.
3. Utility grid condition.

Fault type	Fault prompt	Troubleshooting
Battery Management System (BMS)	BMU Hardware fault	Please contact the distributor/our customer service center.
	BCU Hardware fault	Please contact the dealer/our customer service center.
	Contacting welding	Energy storage system power off, reconnect after 5 minutes. If the fault persists, please contact the dealer/our customer service center.
	BMU Communication fault	<ol style="list-style-type: none"> 1. Check whether the battery package Communication port connector is properly connected or if there is any abnormality. 2. If fault persists, please contact the dealer/our customer service center.
	Current sensor fault	Energy storage system power off, restart after 5 minutes. If fault persists, please contact the distributor/our customer service center.
	Insulation Monitoring Device (IMD)	Energy storage system power off, restart after 5 minutes. If the fault persists, please contact the distributor/our customer service center.
	Total voltage Overvoltage First-Level Alarm	Check whether the total voltage exceeds the Protection threshold when inspecting the Charge system. If the total voltage exceeds the Protection threshold, please contact the dealer/our customer service center.

Total voltage undervoltage first-level alarm	Check whether the total voltage of the system is below the Protection threshold. If the total voltage is below the Protection threshold, please contact the distributor/our customer service center.
Single overvoltage level 1 alarm	Check whether the individual voltage exceeds the Protection threshold during system operation. If the individual voltage exceeds the Protection threshold during Charge, please contact the distributor/our customer service center.
Single unit undervoltage level 1 alarm	Check if the individual voltage of the system is below the Protection threshold. If the individual voltage is below the Protection threshold, please contact the dealer/our customer service center.
Discharge current over-level alarm	Check whether the Discharge current exceeds the Protection threshold during system operation. If the Discharge current exceeds the Protection threshold during Discharge, please contact the distributor/our customer service center.
Charge current primary overcurrent alarm	Check whether the Charge current exceeds the Protection threshold during system operation. If the Charge current exceeds the Protection threshold, please contact the distributor/our customer service center.
Discharge battery Level 1 Overtemperature Alarm	<ol style="list-style-type: none"> 1. Check whether the refrigeration of the liquid cooling unit is operating normally. 2. Check whether the battery temperature exceeds the Protection threshold during system operation. If the battery temperature exceeds the Protection threshold, please contact the distributor/our customer service center.
Discharge battery Low Temperature Level 1 Alarm	<ol style="list-style-type: none"> 1. Check whether the liquid cooling unit heating is operating normally. 2. Check whether the battery temperature is below the Protection threshold during system operation. If the battery temperature is below the Protection threshold, please contact the distributor/our customer service center.

Charge battery first-level overtemperature alarm	<ol style="list-style-type: none"> 1. Check whether the refrigeration of the liquid cooling unit is operating normally. 2. Check whether the battery temperature exceeds the Protection threshold during system operation. If the battery temperature exceeds the Protection threshold, please contact the distributor/our customer service center.
Charge battery Undertemperature Level 1 Alarm	<ol style="list-style-type: none"> 1. Check whether the liquid cooling unit heating is operating normally. 2. Check whether the battery temperature is below the Protection threshold during system operation. If the battery temperature is below the Protection threshold, please contact the distributor/our customer service center.
Insulation resistance too low, first-level Alarm	Energy storage system power off, reconnect after 5 minutes. If fault persists, please contact the dealer/our customer service center.
Pole temperature too high, first-level alarm	Check whether the pole temperature exceeds the Protection threshold during system operation. If the pole temperature exceeds the Protection threshold, please contact the dealer/our customer service center.
Single unit differential pressure too high, first-level alarm	Check whether the single-cell pressure difference exceeds the Protection threshold during system operation. If the single-cell pressure difference exceeds the Protection threshold, please contact the distributor/our customer service center.
Single unit temperature difference too high, first-level alarm	<ol style="list-style-type: none"> 1. Check if the liquid cooling unit is operating normally. 2. Check whether the temperature difference of a single unit exceeds the Protection threshold during system operation. If the temperature difference exceeds the Protection threshold, please contact the distributor/our customer service center.
SOC low-level alarm	For systems with Charge, if the total voltage exceeds 732V and the alarm cannot be cleared, please contact the distributor/our customer

		service center.
	Utility gridvoltage anomaly	<ol style="list-style-type: none"> 1. If Utility grid returns to normal, perform manual recovery according to the recovery method set by energy storage system or allow energy storage system to recover automatically (default is manual recovery). 2. Ensure that the Utility grid, voltage, and Frequency comply with the specifications. 3. Confirm whether the N line and PE line connections are secure.
	Utility gridFrequency anomaly	<ol style="list-style-type: none"> 1. If Utility grid returns to normal, perform manual recovery according to the recovery method set by energy storage system or allow energy storage system to recover automatically (default is manual recovery). 2. Ensure that the Utility grid, voltage, and Frequency comply with the specifications.
	Utility grid loss fault	
PCS (Power Conversion System)	Utility grid overvoltage Protection	<ol style="list-style-type: none"> 1. If it occurs occasionally, it may be a temporary abnormality in Utility grid. Inverter will resume normal operation upon detecting that Utility grid is functioning properly, without requiring manual intervention. 2. If it occurs frequently, check whether the Utility grid voltage is within the allowable range. If not, contact the local power operator. If it is, you also need to modify the Utility grid overvoltage Protection point after obtaining approval from the local power operator. 3. If the issue persists for an extended period, please check whether the breaker on the AC side and the output cables are properly connected.
	Undervoltage	<ol style="list-style-type: none"> 1. If it occurs occasionally, it may be due to a temporary abnormality in Utility grid. The Inverter will resume normal operation upon detecting that Utility grid is back to normal, without requiring manual intervention. 2. If it occurs frequently, check whether the Utility grid voltage is within the allowable range. If not, contact the local power operator. If it is, the Utility

		<p>grid under-voltage Protection point should also be modified after obtaining consent from the local power operator.</p> <p>3. If the issue persists for an extended period, please check whether the breaker on the AC side and the output cables are properly connected.</p>
	Overfrequency	<p>1. If it occurs occasionally, it may be due to a temporary abnormality in Utility grid. Inverter will resume normal operation after detecting that Utility grid is normal, without requiring manual intervention.</p> <p>2. If it occurs frequently, please check whether Utility grid and Frequency are within the allowable range. If not, contact the local power operator. If they are, it is also necessary to modify the Utility grid over-frequency Protection point after obtaining consent from the local power operator.</p>
	Underfrequency	<p>1. If it occurs occasionally, it may be due to a temporary abnormality in Utility grid. The Inverter will resume normal operation once it detects that Utility grid is functioning normally, without requiring manual intervention.</p> <p>2. If this occurs frequently, check whether the Utility grid Frequency is within the allowable range. If not, contact the local power operator. If it is, the Utility grid under frequency protection point should also be modified after obtaining consent from the local power operator.</p>
	Frequency shift protection	<p>1. If it occurs occasionally, it may be due to a temporary abnormality in the Utility grid. The Inverter will resume normal operation after detecting that the Utility grid is functioning properly, without requiring manual intervention.</p> <p>2. If it occurs frequently, check whether the Utility grid and Frequency are within the allowable range. If not, please contact the local power operator.</p>
	Utility grid phase shift Protection	
	Undervoltage	<p>1. If it occurs occasionally, it may be due to a</p>

ride-through	temporary abnormality in the Utility grid. The Inverter will resume normal operation upon detecting that the Utility grid is functioning properly, without requiring manual intervention. 2. If this occurs frequently, check whether the Utility grid, voltage, and Frequency are within the allowable range. If not, please contact the local power operator.
voltage ride-through overvoltage fault	
Waveform detection	
Utility grid phase loss Protection	
Utility grid voltage imbalance	
Utility grid phase fault	<ol style="list-style-type: none"> 1. Check whether the wiring of Inverter and Utility grid is in positive sequence. After the wiring is corrected (e.g., by swapping any two live wires), the fault will automatically disappear. 2. If the wiring is correct and fault persists, please contact the dealer/our customer service center.
Low	<ol style="list-style-type: none"> 1. Check the impedance of the battery cluster to protection ground. If the impedance is low, disconnect the MSD of each battery string and inspect the DC connectors of the system for any abnormalities. 2. If the impedance remains low, please contact the dealer/our customer service center.
Hardware power limit Protection	<ol style="list-style-type: none"> 1. If the abnormality is caused by an external fault, the Inverter will automatically return to normal operation after the fault disappears, without requiring manual intervention. 2. If this alarm occurs frequently and affects the normal power generation of the power station, please contact the distributor/our customer service center.
Internal Communication link broken	Disconnect the AC output side switch and DC input side switch, then close the AC output side switch and DC input side switch after 5 minutes. If fault persists, please contact the dealer/our customer service center.
AC sensor self-check abnormality	
AC sensor	
Relay self-test abnormality	

Relay		
Cavity temperature too high	<ol style="list-style-type: none"> 1. Check if the ventilation of Inverter installation Location is adequate and if the ambient temperature exceeds the maximum allowable range. 2. If there is no ventilation or the ambient temperature is too high, please improve its ventilation and heat dissipation conditions. 3. If ventilation and ambient temperature are normal, please contact the dealer/our customer service center. 	
INV module temperature too high		
Boost module temperature too high		
Output filter capacitor overtemperature		
Bus overvoltage	<p>Disconnect the AC output side switch and DC input side switch, then close the AC output side switch and DC input side switch after 5 minutes. If fault persists, please contact the distributor/our customer service center.</p>	
Upper busbar overvoltage		
Lower busbar overvoltage		
BUS overvoltage (sub-CPU1)		
PBUS overvoltage (sub-CPU1)		
NBUS overvoltage (sub-CPU1)		
BUS overvoltage (sub-CPU2)		
PBUS overvoltage (sub-CPU2)		
NBUS overvoltage (sub-CPU2)		
PBUS overvoltage (CPLD)		
NBUS overvoltage (CPLD)		
MOSFET continuous overvoltage		
BUS short circuit		Please contact the distributor/our customer

		service center.
	BUS sampling	Disconnect the AC output side switch and DC input side switch, then close the AC output side switch and DC input side switch after 5 minutes. If fault persists, please contact the dealer/our customer service center.
	Battery1 Precharge fault	Check whether the pre-charge circuit is in good condition, and verify that the Battery power on post-battery voltage matches the busbar voltage. If they do not match, please contact the distributor/our customer service center.
	Battery1 relay fault	After battery power on, check whether the battery relay operates and if the closing sound is heard. If it does not operate, please contact the dealer/our customer service center.
	Inverter software overcurrent	Occasional occurrences do not require handling; if this alarm appears frequently, please contact the dealer/our customer service center.
	R-phase inverter hardware overcurrent	
	S-phase inverter hardware overcurrent	
	T-phase inverter hardware overcurrent	
	R-phase inverter software overcurrent	
	S-phase inverter software overcurrent	
	T-phase inverter software overcurrent	
	AC side SPD	
Liquid cooling unit	High-temperature water outlet	Check if the compressor of the liquid cooling unit is operating normally. If it is, please contact the dealer/our customer service center.
	Low outlet water temperature	Check if the liquid cooling unit's PTC is operating normally. If it is, please contact the dealer/our

		customer service center.
Outlet Temperature Sensor fault		Disconnect the AC circuit breaker, wait for 1 minute, and then close it again. If the fault is still not cleared, please contact the distributor/our customer service center.
Inverter Communication		Disconnect the AC circuit breaker, wait for 1 minute, and then close it again. If the fault is still not cleared, please contact the distributor/our customer service center.
System High Voltage Lockout		<ol style="list-style-type: none"> 1. If it occurs occasionally, it may be due to a temporary abnormality in the Utility grid. Restart the power on operation. 2. If it occurs frequently, check whether the Utility grid voltage is within the allowable range. If not, contact the local power operator. If it is, the Utility grid high-voltage Protection point should also be modified after obtaining approval from the local power operator.
System low voltage lockout		<ol style="list-style-type: none"> 1. If it occurs occasionally, it may be a temporary anomaly in the Utility grid, and the system should be power on restarted. 2. If it occurs frequently, check whether the Utility grid voltage is within the allowable range. If not, contact the local power operator. If it is, the Utility grid low-voltage Protection point should also be modified after obtaining consent from the local power operator.
Exhaust temperature too high lockout		<ol style="list-style-type: none"> 1. If it occurs occasionally, it may be due to temporary machine anomalies; restart the power on operation. 2. If it occurs frequently, please contact the dealer/our customer service center.
Inverter overcurrent lockout		
Inverter overtemperature lockout		
Inverter overvoltage lockout		
Inverter undervoltage lockout		
Inverter phase loss lockout		
Water replenishment alarm		

	System pressure too high alarm	<ol style="list-style-type: none"> 1. If it occurs occasionally, it may be due to a temporary machine anomaly. Restart the power on operation. 2. If it occurs frequently, please contact the distributor/our customer service center.
	High outlet pressure alarm	
EMS	CT not connected	Check CT wiring
	CT reverse connection	
	Smoke Alarm	<ol style="list-style-type: none"> 1. If it occurs occasionally, it may be due to a temporary sensor anomaly. Restart the power on operation. 2. If it occurs frequently, please contact the dealer/our customer service center.
	Water Immersion Alarm	Check if there is water immersion inside the cabinet. If not, please contact the distributor/our customer service center.
	PACK fire alarm	Prepare for fire extinguishing and contact the distributor/our customer service center.
	Cluster-level fire alarm	Prepare for fire extinguishing and contact the distributor/our customer service center.

10.5 Routine Maintenance

DANGER

When performing operation and maintenance on the energy storage system, ensure the energy storage system is power off. Operating live equipment may cause damage to the energy storage system or result in electric shock danger.

Maintenance content	Maintenance method	Maintenance cycle
System appearance	Check for any foreign objects or dust at the inlet/outlet, ensure the appearance is clean, and verify that the operation indicator light is on.	Once every six months to once a year
WiFi	Check if the antenna is detached, has a normal appearance, and functions properly.	Once every six months to once a year

Cabinet liquid cooling unit dustproof cotton	Rinse with purified water	Once every six months to once a year
MSD switch, molded case circuit breaker (MCCB), auxiliary power switch, emergency stop switch	Open and close the switch three times consecutively to ensure its proper functioning.	1times/year
Electrical connection	Check whether the electrical connections are loose, and inspect the cables for any visible damage or exposed copper.	1Once every six months to once a year
Liquid cooling system	Check whether the equipment inlet hole sealing meets the requirements. If there is a gap that is too large or unsealed, it must be resealed.	1times/year
Fire Protection System (Hot Aerosol)	Comprehensive inspection and maintenance of thermal aerosol temperature-sensitive automatic fire extinguishing devices: <ol style="list-style-type: none"> 1. Check the aerosol fire extinguishing device for any physical damage; 2. Observe the operation of smoke and temperature sensors, and check whether the sensors are functioning normally. 3. Inspect the installation mounting structure and related hardware for any loose, damaged, or broken components. 	1times/year
PCS testing	Charging test, off-grid operation test, initialization test, system shutdown test, remote test.	For the first installation or after maintenance, subject to demand
Local EMS Testing	Indicator test experiment.	Initial installation or after maintenance, Depending on the demand

Dust removal maintenance for air inlet and outlet	Check the inlet/outlet for any foreign objects or dust.	1times/half year
---	---	------------------

11 Technical Parameters

Technical Data	GW125/261-ESA-LCN-G10
Battery Data	
Cell Type	LFP (LiFePO4)
Cell Capacity (Ah)	314
Module Nominal Energy (kWh)	52.25
Number of Packs	5
Rack Nominal Energy (kWh)	261.25
Rack Usable Energy (kWh)	261.25
Nominal Voltage (V)	832
Operating Voltage Range (V)	676~936
Max Continuous Charge/Discharge Current (A)	188
Max. Charge/ Discharge Current (A)	198.5
Max. Charge/ Discharge Rate	0.5P
Depth of Discharge	90%~100% (90%Recommended)
AC Output Data (On-grid)	
Nominal Output Power (kW)	125
Max. Output Power (kW)	137.5@400V AC 130.6@380V AC
Nominal Apparent Power(kVA)	125
Nominal Output Apparent Power to Grid (kVA)	125
Nominal Input Apparent Power from Grid (kVA)	125
Max. Apparent Power (kVA)	137.5@400V AC 130.6@380V AC
Max. Output Apparent Power to Grid (kVA)	137.5@400V AC 130.6@380V AC
Max. Input Apparent Power from Grid (kVA)	137.5@400V AC 130.6@380V AC
Nominal Output Voltage (V)	400/380, 3L/N/PE

Output Voltage Range (V)	340~440/323~418
Nominal Output Frequency (Hz)	50/60
AC Grid Frequency Range (Hz)	47.5~52.5 /57.5~62.5
Max. AC Output Current (A)	198.5
Max. AC Current Output to Grid (A)	198.5
Max. AC Current from Grid (A)	198.5
Nominal Output Current (A)	180.4@400V AC 189.9@380V AC
Power Factor	~1 (0.8lag to 0.8lead)
Output THDi (@Linear Load)	<3%
AC Output Data (Off-grid)	
Nominal Output Power (kW)	125
Max. Output Power (kW)	137.5@400V AC 130.6@380V AC
Nominal Apparent Power(kVA)	125
Nominal Output Apparent Power to Grid (kVA)	125
Nominal Input Apparent Power from Grid (kVA)	125
Max. Apparent Power (kVA)	137.5@400V AC 130.6@380V AC
Max. Output Apparent Power to Grid (kVA)	137.5@400V AC 130.6@380V AC
Max. Input Apparent Power from Grid (kVA)	137.5@400V AC 130.6@380V AC
Nominal Output Voltage (V)	400/380, 3L/N/PE
Output Voltage Range (V)	340~440/323~418
Nominal Output Frequency (Hz)	50/60
AC Grid Frequency Range (Hz)	47.5~52.5 /57.5~62.5
Max. AC Output Current (A)	198.5
Max. AC Current Output to Grid (A)	198.5
Max. AC Current from Grid (A)	198.5

Nominal Output Current (A)	180.4@400V AC 189.9@380V AC
Power Factor	~1 (0.8lag to 0.8lead)
Output THDi (@Linear Load)	<3%
Efficiency	
Max. PCS Efficiency	98.6%
Max. System Efficiency* ¹	92%
Protection	
Battery Reverse Polarity Protection	Intergrate
Anti-islanding Protection	Intergrate
AC Overcurrent Protection	Intergrate
AC Short Circuit Protection	Intergrate
AC Surge Protection	Type II
General Data	
Operation temperature range (°C)	-25~+55
Derating temperature (°C)	45
Storage Temperature (°C)	-20~+45 (One Month) 0~+35 (One Year)
Relative Humidity	10 ~ 95%
Max. Operating Altitude (m)	4000 (2000 derating)
Cooling Method	Pack : Liquid Cooling PCS : Smart Fan Cooling
User Interface	LED, WLAN+APP
Communication Protocol	Modbus TCP, Modbus RTU
Weight (kg)	2580
Dimension (W×H×D mm)	1050*2250*1400
Noise Emission (dB)	≤70
Topology	Non-isolated
Ingress Protection Rating	IP54

Configuration of safety	aerosol+water-based fire suppression, explosion-proof fan + explosion-proof plates (optional)
Anti-Corrosion	C4(C5 option)
Charge/ Discharge Switching Time	< 60ms



GoodWe Technologies Co.,Ltd.

No. 90 Zijin Rd., New District, Suzhou, 215011, China

400-998-1212

www.goodwe.com

service@goodwe.com