

# Data Sheet | Item Number: 2773-2401

PUSH WIRE® Inline Splicing Connector; for solid and stranded conductors; max. 4 mm<sup>2</sup>; 2-conductor; transparent housing; Transparent cover; Surrounding air temperature: max 85°C (T85); 4,00 mm<sup>2</sup>; transparent



<https://www.wago.com/2773-2401>



Color:  transparent

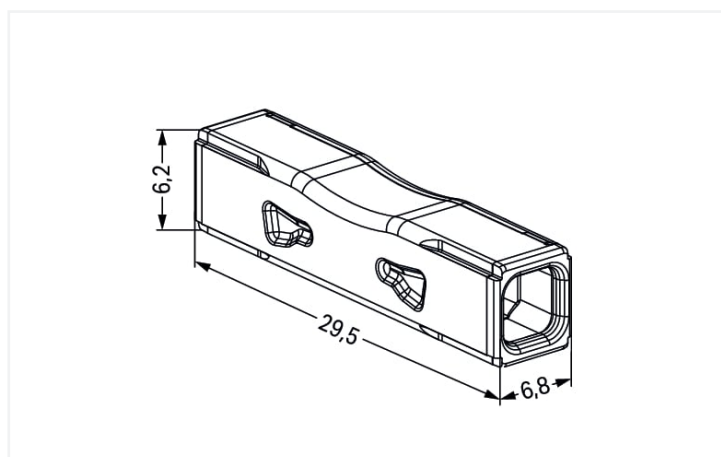

## Electrical data

Ratings per	EN 60664		
Overvoltage category	III	III	II
Pollution degree	3	2	2
Nominal voltage	-	-	450 V
Rated surge voltage	-	-	4 kV
Rated current	-	-	32 A

Approvals per	UL 486C		
Use group	B	C	D
Rated voltage	-	600 V	-
Rated current	-	20 A	-

## Connection data

### Connection 1

Solid conductor	0.75 ... 4 mm <sup>2</sup> / 18 ... 12 AWG
Stranded conductor	1.5 ... 4 mm <sup>2</sup>
Fine-stranded conductor; with insulated ferrule	0.75 ... 1.5 mm <sup>2</sup> / 18 ... 16 AWG
Fine-stranded conductor; with uninsulated ferrule	1 ... 1.5 mm <sup>2</sup> / 16 AWG
Conductor diameter	1.6 ... 2 mm / 18 ... 12 AWG
Strip length	10 ... 11 mm / 0.39 ... 0.43 inches

## Physical data

Width	6.8 mm / 0.268 inches
Height	6.15 mm / 0.242 inches
Depth	29.5 mm / 1.161 inches

## Material data

Note (material data)	<a href="https://www.wago.com/us/material-specifications">Information on material specifications can be found here</a>
Color	transparent
Cover color	transparent
Material group	IIIa
Insulation material	Polycarbonate (PC)
Flammability class per UL94	V2
Clamping spring material	Chrome-nickel spring steel (CrNi)
Contact material	Electrolytic copper (E <sub>Cu</sub> )
Contact plating	Tin
Fire load	0.038 MJ
Weight of insulation material	0.8 g
Weight	1.4 g

## Environmental requirements

Processing temperature	-35 ... +60 °C
Continuous operating temperature	105 °C

## Commercial data

PU (SPU)	1000 (100) pcs
Country of origin	CH
GTIN	4066966321630
Customs tariff number	85369010000

**Environmental Product Compliance**

RoHS Compliance Status Compliant, No Exemption

**Approvals / Certificates**

General approvals			Declarations of conformity and manufacturer's declarations								
			<table border="1"> <thead> <tr> <th>Approval</th> <th>Standard</th> <th>Certificate Name</th> </tr> </thead> <tbody> <tr> <td>EU-Declaration of Conformity WAGO GmbH &amp; Co. KG</td> <td>-</td> <td>-</td> </tr> </tbody> </table>			Approval	Standard	Certificate Name	EU-Declaration of Conformity WAGO GmbH & Co. KG	-	-
Approval	Standard	Certificate Name									
EU-Declaration of Conformity WAGO GmbH & Co. KG	-	-									
<b>Approval</b>	<b>Standard</b>	<b>Certificate Name</b>									
CB DEKRA Certification B.V.	IEC 60998	NL-86543									
cULus_Listed_667F Underwriters Laboratories Inc.	UL 486C	E69654									
ENEC 05 DEKRA Certification B.V.	EN 60998	71-127515									

**Downloads**

**Environmental Product Compliance**

Compliance Search
Environmental Product Compliance 2773-2401 <a href="#">↓</a>

**CAD/CAE-Data**

CAD data
2D/3D Models 2773-2401 <a href="#">↓</a>

**1 Compatible Products**

**1.1 Optional Accessories**

**1.1.1 General accessories**

**1.1.1.1 Installation terminal block**



**Item No.: 207-5485/316-000**  
 cable repair set; for multicore cables; Straight-through; with glue; Cable diameter 8 - 24 mm; with enclosed splicing connectors; medium-walled; black

### Installation Notes

#### Conductor termination



Strip conductor to 10 mm.



Insert the conductor.



Check for the correct conductor position.

#### Conductor removal



Twist the connector alternately left and right while pulling it off the conductor.

#### Application



Wiring conductors in a flush-mounted junction box.

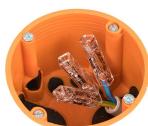

Extending short wires.

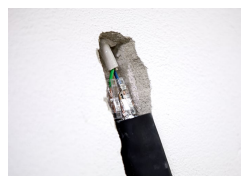

Use with a shrink tube



Use of the inline splicing connector (for plugging in with a shrink tube) in the cable repair set 207-5485/316-000.

#### Application



Damaged cable



Strip the damaged cable approx. 10 cm uniformly around the damaged area.



Cut out the damaged areas in the copper and disconnect all other conductors. For damaged areas between 1 mm and 30 mm, at least 30 mm of the damaged conductor must be removed. Tip: A connector (approx. 30 mm long) can be used as a length guide.



Strip conductor and conductor bridge to 10 mm specified and insert into connector. Only one connector is required for damage points < 1 mm or conductors with a flat cut. Two connectors with wire jumpers must be used for damage points > 1 mm.



Strip 10 mm conductor per specification and insert connector (example shows staggered connectors).



Pull the shrink tube over the cable end.



The shrink tube must have an overlap length of at least 30 mm on the cable sheath.



Heat the shrink tube evenly with a hot air blower between 110°C and 200°C.

