





- Retains all impurities
- Self-cleaning
- Excellent hydraulic properties
- Can be mounted on vertical, horizontal and diagonal piping
- Increases the lifespan of the boiler
- Fights corrosion
- Maintains optimum system efficiency
- Easy dosing of the treatment fluids with 0.13 gal (500 ml) doses
- Total passage isolating valves

PRODUCTION RANGE

	Code	Size	Connection	Diverter body
	2344.05.50N	3/4"	NPT female ANSI/ASME B1.20.1 with ball valves	Brass
	2344.06.50N	1"		Brass
	2319.05.50N	3/4"	NPT female ANSI/ASME B1.20.1 with ball valves	Polymer
	2319.06.50N	1"		Polymer

DESCRIPTION

SafeCleaner2 by **RBM** represents the best solution to solve plant problems due to particle presence, especially rust and sand that are formed due to corrosion and scale during the normal operation of a system.

OPERATING PRINCIPLE: Through its effective and constant action, the magnetic filter collects all the impurities present in the system, preventing them from circulating within it, thus avoiding wear and damage of the rest of the components making up the system, circulators and heat exchangers in particular.
SafeCleaner2 performs as continuous protective action on the boiler.

USE: It is advised to install **SafeCleaner2** on the return circuit, at the inlet of the boiler, in order to protect it from any impurities in the system, especially during the start-up phase.

It is important to **follow the direction indicated by the arrow** on the body to ensure the maximum efficiency of the filtering action.

The jointed part allows installation on vertical, horizontal and diagonal piping.

Thanks to its jointed seal and to the presence of an opening cap, **SafeCleaner2** is suitable to easily add chemicals for the treatment of the system.

SafeCleaner2 is characterised by a great dosing capacity 0.13 gal (500 ml). See paragraph "Adding treatment fluids" for instructions.

DEGREE OF FILTRATION: **SafeCleaner2** removes any magnetic and non-magnetic particles that may cause damages to the system during the first day of operation.

The continuous passage of the fluid through the filter during the normal operation of the system on which it is installed, gradually removes any dirt.

WARNINGS: This filter contains powerful magnet, and strong magnetic fields are present within it.

We recommend the holders of pacemaker devices to keep at a safe distance during the filter operation and / or maintenance. Pay attention to the use of electronic equipment in the vicinity of the magnets, so as not to affect their operation.

CONSTRUCTION FEATURES

- Diverter body: Nickel-plated brass / Polyamide PA66 + 30% FG (2 different versions)
 - Cartridge body: Polyamide PA66 + 30% FG
 - Locking ring: Polyamide PA66 + 30% FG
 - Filter cap: Polyamide PA66 + 30% FG
 - Filtering cartridge: Stainless steel
 - Hydraulic seals: Elastomer
 - Magnet: Neodymium
- $B(\text{MaxT}) / B(\text{RoomT})^* < 1\%$ (where MaxT = 265°F, RoomT = 70°F)
 Tested according to IEC 60404-5 & ASTM A977 regulations

TECHNICAL FEATURES

- Compatible fluid: Water - Water + Glycol 30%
- Max. operating pressure: 60 psi
- Operating temperature: 32 - 195 °F
- Noise induced (according to EN13443 and UNI 3822)
 Both the specific tests (44 psi with 9.5 gpm - 73 psi with 12.4 gpm) carried out at an accredited laboratory shown that the noise induced by *SafeCleaner2* in the piping is **0 dB(A)**. As specified in EN 13443 regulation, *SafeCleaner2* belongs to the **I group**, as well as all other products having noise levels **< 20 dB(A)**.

DIMENSIONAL FEATURES

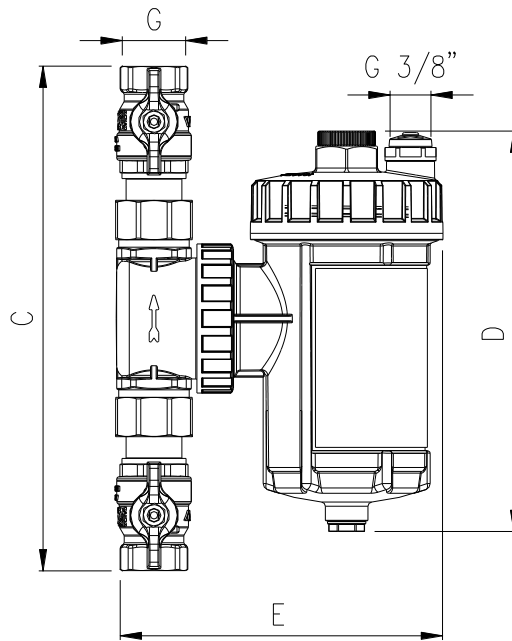

Code	G	C [In]	D [In]	E [In]
2344.05.50N	3/4" NPT female	9.33"	7.44"	6.02"
2344.06.50N	1" NPT female	9.96"	7.44"	6.02"
2319.05.50N	3/4" NPT female	9.33"	7.44"	6.02"
2319.06.50N	1" NPT female	9.96"	7.44"	6.02"

FLUID DYNAMICS FEATURES

Load loss diagram

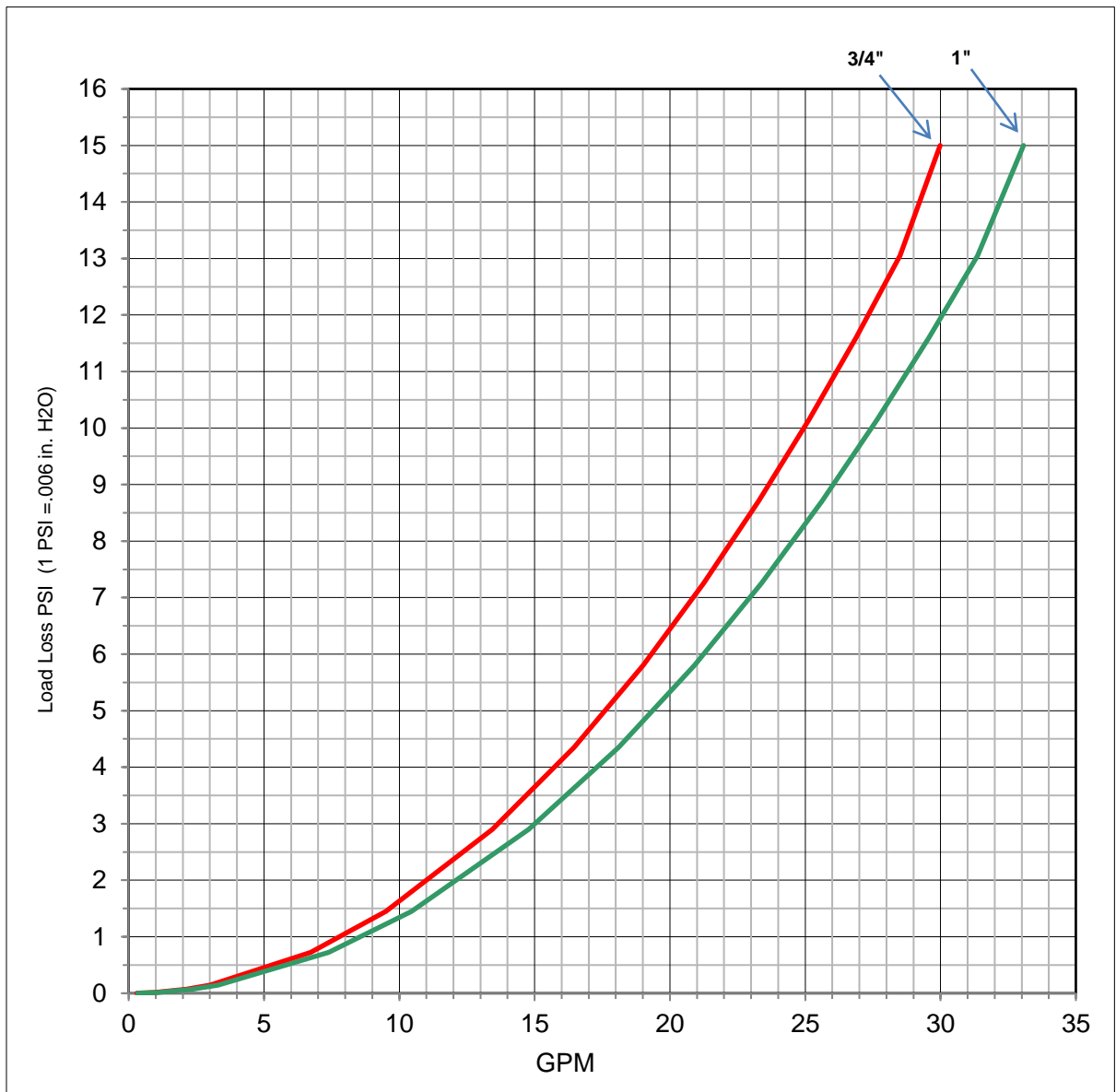

Size	Cv [GPM]
3/4"	26
1"	28.5

Q = Flow rate GPM

OPERATING PRINCIPLE

By going through a set course, the fluid is forced to cross the mesh of the cartridge and enter the filtration chamber.

In the filtration chamber, thanks to the simultaneous action of:

- filtering cartridge
- magnet
- direction of the fluid given by the specific internal geometry

in the different phases, water is filtered from ferrous sludge.

First of all, the sudden cross-section variation (the filtering chamber has a much greater diameter than the conduit) slows down the fluid motion and, consequently, the entrainment rate of the particles suspended in it.

The particles collide with the mesh of the filter cartridge and then slow down.

The heavier particles fall downwards due to gravity, which prevails over the drag force.

The magnet, placed inside a cylinder at the centre of the filtration chamber, attracts all the impurities having magnetic characteristics.

In this way, all magnetic (ferrous residues) and non-magnetic (algae, sludge, sand, ...) contaminants in the system are retained in the filtration chamber.

The cartridge, composed of 2 stainless steel sheets, was developed in order not to exert excessive resistance to the passage of fluid (low load losses) and to favour a motion of the fluid itself that contributes to bring the heaviest particles to the bottom.

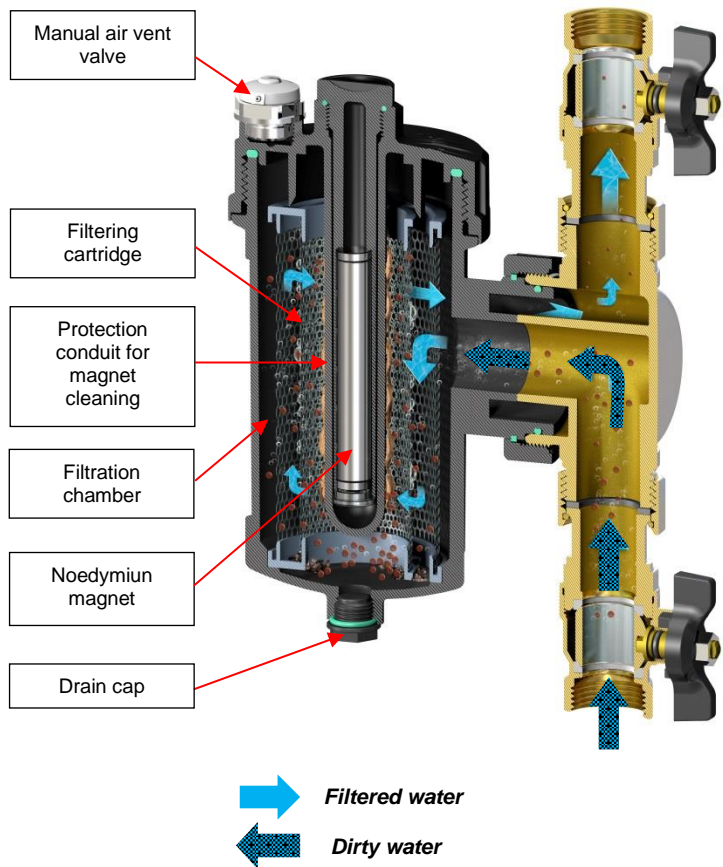

INSTALLATION

- It is advised to install *SafeCleaner2* on the return circuit, at the inlet of the boiler, in order to protect it from any impurities in the system, especially during the start-up phase.
It is important to **follow the direction indicated by the arrow** on the body to ensure the maximum efficiency of the filtering action.

- *SafeCleaner2* must be installed with the cartridge/filter cap **facing upwards**.

The jointed part allows installation on:

- VERTICAL
- HORIZONTAL
- DIAGONAL piping

The sealing between the jointed part and the rest of the body is telescopic, therefore it does not depend on the strength with which the adjustment ring nut is tightened.

In the upper part of the filter there is a manual air vent valve G 3/8".

This can be used to eliminate air that was not expelled during refill, or micro-bubbles that may form following processes that occur during the normal operation of the system.

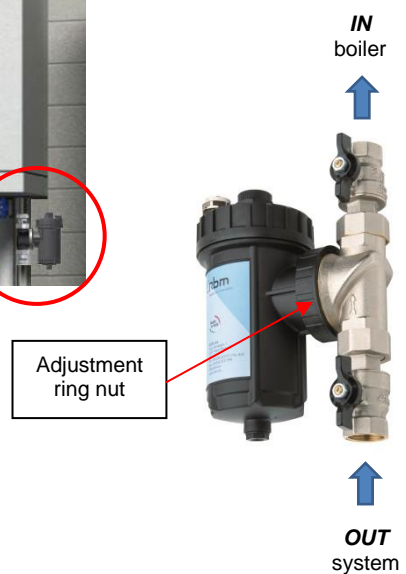

MAINTENANCE INTERVENTIONS

FILTERING CARTRIDGE CLEANING:

The choice to build a large chamber for separating impurities and to use a large-mesh steel filter, avoid the clogging of the filter. However, in case of large impurities, it is possible to perform cartridge cleaning operations by extracting the magnet or, alternatively, by completely unscrewing the filter cap.

Before cleaning *SafeCleaner2*, ensure the working environment is safe.

RBM recommends that the boiler is off and the system is allowed to cool at a room temperature before carrying out any maintenance intervention, in order to avoid burns.

- Intercept the filter to be serviced by closing the two ball valves.

- Vent the air/pressure in the body of the filter by opening the manual vent valve.

- Unscrew the magnet from the cap and pull it out so as to easily eliminate ferrous particles.

- Unscrew the drain cap: water will gradually drain, dragging out ferrous impurities and sediments captured by the filter.

Ensure that water is collected in a container of suitable dimensions.

Possibly, the filter cap can be completely removed so as to extract the filtering mesh and allow for cleaning and replacement operations.

Wash with water and thoroughly rinse under the tap to completely remove any impurities.

Ensure the O-ring seal is not damaged; if necessary, replace it.

Reassemble in reverse order.

Ensure there are no leaks prior to recommissioning.

It is important to perform the cleaning operation at least once a year.

In case of first application, perform the first cleaning after a month.

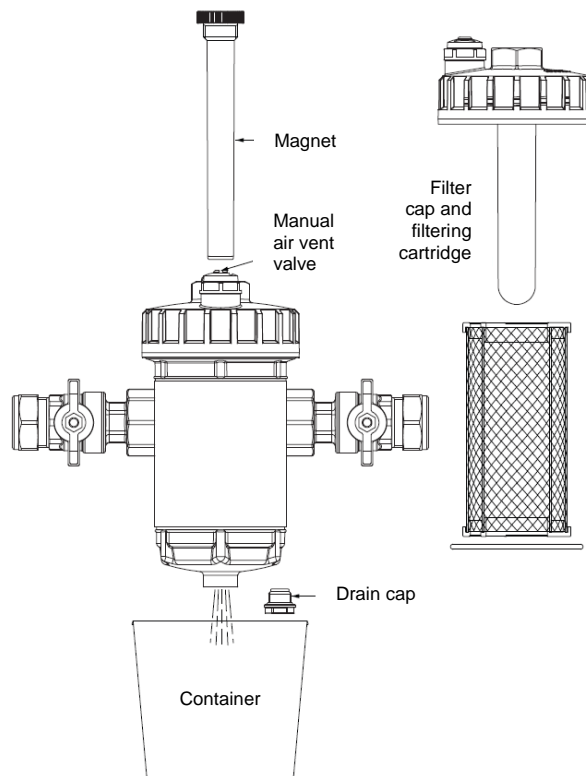

ADDING TREATMENT FLUIDS

To add chemicals for the treatment of the heating system by using *SafeCleaner2*, follow the instructions below:

- Ensure the system is correctly insulated, then close both the isolating valves.

- Ensure the cartridge/filter cap is **facing upwards**.

- Loosen the lower drain cap.

- Slightly unscrew the closure filter cap until water flows from the lower hole.

- When water is completely drained, screw the drain cap again.

- Pour the treatment fluid inside the *SafeCleaner2* after removing the filter cap. (*SafeCleaner2* has a dosing capacity of 0.13 gal (500 ml)). Alternatively, it is possible to pour the treatment fluid through a smaller hole located under the manual air vent valve.

- Screw the filter cap (or the manual air vent valve), reopen the isolating valves and restart the system. If necessary, bring the operating pressure of the system to nominal values (not necessary if an RBM power supply is used).

SPECIFICATION ITEMS

SERIES 2319

Multifunction magnetic dirt separator filter, with FF ball valves connection, model *SafeCleaner2*. Cartridge holder body in polymer.

Diverter in polymer. Stainless steel filtering cartridge. Seals in elastomer. Threaded connections FF ANSI/ASME B1.20.1.

Max operating pressure 60 psi. Operating temperature 32-195°F. Neodymium magnet B = 11.000 gauss. $B(\text{Max T}) / B(\text{Room T})^* < 1\%$ where * Max T = 265°F - Room T = 70°F. Retains all impurities; Can be mounted on vertical, horizontal and diagonal piping; Excellent hydraulic properties; Increases the lifespan of the boiler; Fights corrosion; Maintains optimum system efficiency; Total passage isolating valves. Available sizes 3/4" - 1".

SERIES 2344

Multifunction magnetic dirt separator filter, with FF ball valves connection, model *SafeCleaner2*. Cartridge holder body in polymer. Nickel-plated brass diverter. Stainless steel filtering cartridge. Seals in elastomer. Threaded connections FF ANSI/ASME B1.20.1.

Max operating pressure 60 psi. Operating temperature 32-195°F. Neodymium magnet B = 11.000 gauss. $B(\text{Max T}) / B(\text{Room T})^* < 1\%$ where * Max T = 265°F - Room T = 70°F. Retains all impurities; Can be mounted on vertical, horizontal and diagonal piping; Excellent hydraulic properties; Increases the lifespan of the boiler; Fights corrosion; Maintains optimum system efficiency; Total passage isolating valves. Available sizes 3/4" - 1".



RBM spa reserves the right to improve and change the described products and related technical data at any moment and without prior notice; always refer to the instructions attached with the supplied components; this sheet is an aid, should the instructions be extremely schematic. Our technical office is always at your disposal for any doubt, problem or explanation.

