

Data Sheet | Item Number: 771-9393/3267-301

pre-assembled connecting cable; Cca; Plug/open-ended; 3-pole; Cod. A; H05Z1Z1-F 3G 2.5 mm²; 3 m; 2,50 mm²; black

<https://www.wago.com/771-9393/3267-301>



Color: ■ black

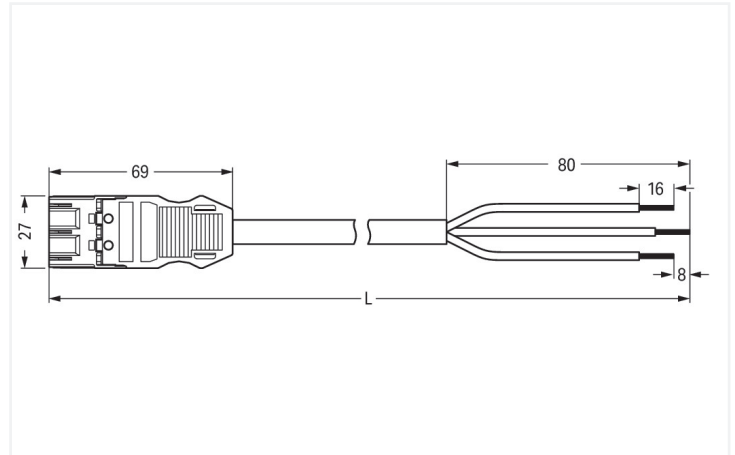

Dimensions in mm

Cable assembly WINSTA® MIDI with protection type IP20

The WINSTA® MIDI cable assembly rated current 20 A supports fast, reliable installation. WAGO pluggable installation connectors are used when requirements repeat or are planned on a specific grid, for example for installing grid lighting or flush-mount lighting. The color coding and mechanical coding of the pluggable installation connector ensure error-free installation of the individual components – including protection against mismatching. The pluggable installation connector offers touch-proof protection with live components in accordance with protection type IP20 (When mated: IP2xC (These compact connectors are not designed for use in open, easily accessible areas!)). The WINSTA® MIDI pluggable installation connector with A coding in white or black is normally used for general mains applications in power distribution. This pluggable installation connector is designed for a voltage load of up to 20 A. Therefore, it can also be used for high power loads. Our WINSTA® MIDI product line guarantees total flexibility for the installation of applications. Through its Push-in CAGE CLAMP® spring pressure connection technology, it ensures time-saving, error-free installation and offers customization for meeting all installation requirements. If you need to meet stricter safety standards, you should use cables with fire class C. These are suitable for use in buildings with particularly high demands on safety. Not using halogen additives in the production of this cable assembly significantly improves fire safety and reduces environmental contamination.

Pluggable connections instead of screw connections – cable assemblies from WAGO

The cable assembly is provided with a plug and a free end. The WINSTA® Pluggable Connection System is perfectly tailored to the strict requirements of building installation. It makes electrical installation pluggable, and thus more efficient, more reliable, and error-free. Using this pre-assembled system reduces time spent on assembly and errors during installation at the construction site. Enjoy the benefits of the pluggable version of our maintenance-free spring pressure connection technology too! Plan your installation with with protection type IP20 from WAGO.

- pluggable installation connectors with protection against mismatching
- simple circuits
- with A coding for a great number of uses
- ready for immediate use
- rapid, structured electrical installation

Notes

Note Cables with a different fire class can be found in the eShop.

Electrical data

Ratings per	IEC/EN 60664-1			General information	
Overvoltage category	III	III	II	Note on contact resistance	approx. 1 mΩ of contact resistance approx. 0.25 mΩ contact transition plug/ socket
Pollution degree	3	2	2		
Nominal voltage	250 V	-	-		
Rated impulse withstand voltage	4 kV	-	-		
Rated current	20 A	-	-		

Connection Data

Total number of potentials	3	Connection 1	
PE function	Preceding PE contact	Strip length	16 mm / 0.63 inches
Conductor preparation	ultrasonically tip-bonded	Pole number	3
		Wire cross-section	2.5 mm ²
		Strip length (outer insulation)	80 mm
		Connection type	Plug - free end

Physical data

Pin spacing	10 mm / 0.394 inches
Width	27 mm / 1.063 inches
Height	12.9 mm / 0.508 inches
Total length	3 m

Mechanical data

Use	General mains applications
Coding	A
Variable coding	Yes
Marking	L ⊕ N
Potential marking	L ⊕ N
Mating force of a plug-in connection	approx. 20 ... 70 N (depending on pole number)
Retention force of a plug-in connection	when locked: > 80N
Unmating force of a plug-in connection	when unlocked: approx. 20 ... 70 N (depending on pole number)
Number of mating cycles	200, without resistive load
Connection type	Plug - free end
Type of pre-assembled cable	Connecting cable
Cable type	H05Z1Z1-F 3G2.5
Protection type	IP20; When mated: IP2xC (These compact connectors are not designed for use in open, easily accessible areas!)
Suitable	for switches and outlet installation

Plug-in connection

Mismating protection	Yes
Note on mismating protection	All WINSTA® components are 100% protected against mismating when: a.) plugging different numbers of poles b.) plugging while rotated 180 c.) plugging while laterally staggered d.) plugging one pole
Locking lever	Can be retrofitted
Locking of plug-in connection	Locking lever
Note on locking system	All connectors for mounted installations (snap-in versions for lighting fixtures or devices, all types of PCB and distribution connectors) are factory-equipped with locking levers to ensure plugs and sockets are securely locked. Additional locking levers are only required for flying leads (plug/socket).

Material data

Note (material data)	Information on material specifications can be found here
Color	black
Insulation material (main housing)	Polyamide (PA66)
Flammability class per UL94	V0
Fire class per EN 50575	C _{ca}
Contact material	Copper or copper alloy; surface-treated
Contact Plating	Tin
Fire load	46.674 MJ
Connector color	black
Strain relief color	black
Printing color of strain relief	white
Sheathed cable color	black
Printing color of sheathed cable	white
Halogen-free	Yes
Silicon-free	Yes
Sheath material	Halogen-free
Rubber cable	No
Weight	485.8 g
Copper weight of the raw cable	0.072 kg/m

Environmental requirements

Processing temperature	-5 ... +40 °C
Continuous operating temperature	-35 ... +85 °C
Note on continuous operating temperature	Cable for temperatures ≤ 70 °C (including halogen-free) Insulating parts for temperatures ≤ 105 °C

Commercial data

PU (SPU)	1 pcs
Packaging type	unpacked
Country of origin	DE
GTIN	4055143779098
Customs tariff number	85444290900

Product Classification

UNSPSC	26121629
eCl@ss 10.0	27-44-06-04
eCl@ss 9.0	27-44-06-04
ETIM 9.0	EC002587
ETIM 10.0	EC002587
ECCN	NO US CLASSIFICATION

Environmental Product Compliance

RoHS Compliance Status	Compliant, No Exemption
------------------------	-------------------------

Downloads

Environmental Product Compliance

Compliance Search

Environmental Product Compliance 771-9393/3267-301	↓
-------------------------------------------------------	---

CAD/CAE-Data

CAE data

EPLAN Data Portal 771-9393/3267-301	↓
----------------------------------------	---

1 Compatible Products

1.1 Required Accessories

1.1.1 Locking system

1.1.1.1 Locking system

Item No.: 770-101 Locking lever; for flying leads; for manual operation; black	Item No.: 770-121 Locking lever; for flying leads; for manual operation; white	Item No.: 770-111 Locking lever; for flying leads; for tool operation; black	Item No.: 770-131 Locking lever; for flying leads; for tool operation; white

1.2 Optional Accessories

1.2.1 Cover

1.2.1.1 Cover

Item No.: 770-360 Lockout cap; for plugs; 5-pole; separable; yellow	Item No.: 897-2003 Protective cap; Type2; for sockets and plugs; PVC; red

1.2.2 Installation

1.2.2.1 Mounting accessories



Item No.: 770-310

Mounting carrier; 2- to 5-pole; for flying leads; black

1.2.3 Marking

1.2.3.1 Marker



Item No.: 770-450/000-006

Marker card; Plastic; blue



Item No.: 770-450/000-001

Marker card; Plastic; green



Item No.: 770-450/000-012

Marker card; Plastic; orange



Item No.: 770-450/000-005

Marker card; Plastic; red



Item No.: 770-450

Marker card; Plastic; white



Item No.: 770-450/000-002

Marker card; Plastic; yellow

1.2.3.2 Marking strip



Item No.: 210-334

Marking strips; as a DIN A4 sheet; Strip width 5 mm; Strip length 182 mm; plain; Self-adhesive; white