

## Data Sheet | Item Number: 891-8282/216-301

pre-assembled connecting cable; B2ca; Plug/open-ended; 2-pole; Cod. I; H05Z1Z1-F 2 x 1,50 mm<sup>2</sup>; 3 m; 1,50 mm<sup>2</sup>; blue

<https://www.wago.com/891-8282/216-301>

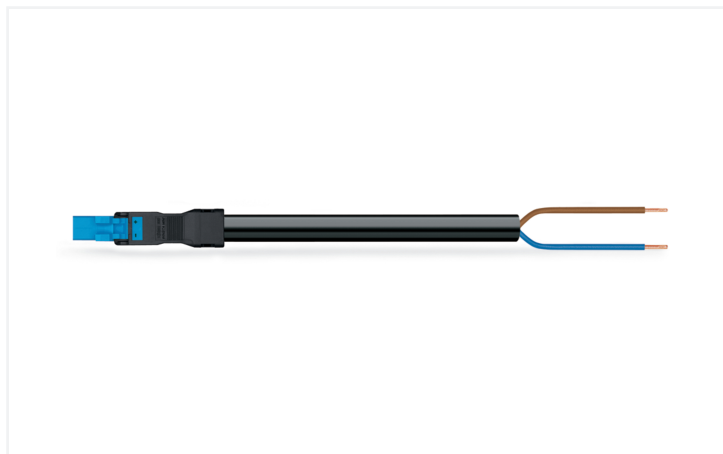

Color: ■ blue

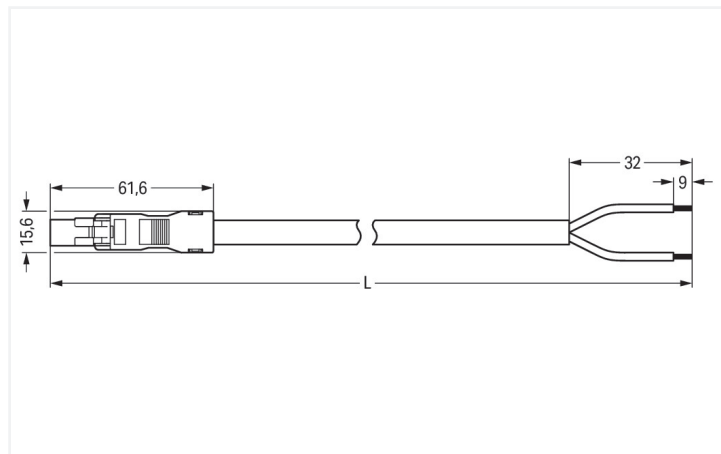

Dimensions in mm

### Cable assembly WINSTA® MINI I coding

For signal and power transmission: The WINSTA® MINI cable assembly with protection against mismatching. The pluggable installation connectors with spring pressure connection technology work without screw connections. They allow fast, efficient, error-free installation in numerous applications. For greater protection in electrical installations, the pluggable installation connector is equipped with mechanical protection against mismatching. Regulated lighting equipment, as implemented with the DALI standard, for instance, is the main application of WINSTA® MINI pluggable installation connectors with I coding. WINSTA® MINI is our response to the trend toward miniaturisation. Our smallest pluggable connection system is very good for lights, for example, since due to LED technology, these offer significantly less space for the connection technology. Compliance with fire protection regulations is an important issue for building installation. Especially in sensitive areas, the fire class must meet or even exceed extensive requirements. This product complies with the requirements of fire class B2. In the manufacturing of this cable assembly, halogens were deliberately omitted. This is an important contribution to climate protection.

### Pluggable connections instead of screw connections – cable assemblies from WAGO

A plug and a free end are provided. The WINSTA® Pluggable Connection System is perfectly tailored to the strict requirements of building installation. It makes electrical installation pluggable, and consequently faster, more reliable, and error-free. Using this pre-assembled system reduces assembly times and errors during installation at the construction site. Choose quality and durability – with protection type IP20 from WAGO makes the electrical installation of electrical components significantly easier.

- protection against mismatching eliminates errors
- compact design for conductors with a cross-section up to 1.5 mm<sup>2</sup>
- with I coding for use in the automation of buildings (lighting control)
- exact dimensions
- rapid, structured electrical installation

### Notes

Note

Cables with a different fire class can be found in the eShop.

## Electrical data

Ratings per	IEC/EN 60664-1		
Overvoltage category	III	III	II
Pollution degree	3	2	2
Nominal voltage	250 V	-	-
Rated impulse withstand voltage	4 kV	-	-
Rated current	16 A	-	-

## General information

Note on contact resistance	approx. 1 mΩ of contact resistance approx. 0.25 mΩ contact transition plug/ socket
----------------------------	--

## Connection Data

Total number of potentials	2
Conductor preparation	ultrasonically tip-bonded

## Connection 1

Strip length	9 mm / 0.35 inches
Pole number	2
Wire cross-section	1.5 mm <sup>2</sup>
Strip length (outer insulation)	32 mm
Connection type	Plug - free end

## Physical data

Pin spacing	4.4 mm / 0.173 inches
Width	15.6 mm / 0.614 inches
Height	13.2 mm / 0.52 inches
Total length	3 m

## Mechanical data

Use	DALI, Lighting Management
Coding	I
Variable coding	No
Marking	+ -
Potential marking	+ -
Mating force of a plug-in connection	approx. 20 ... 70 N (depending on pole number)
Retention force of a plug-in connection	when locked: > 80N
Unmating force of a plug-in connection	when unlocked: approx. 20 ... 70 N (depending on pole number)
Number of mating cycles	200, without resistive load
Connection type	Plug - free end
Type of pre-assembled cable	Connecting cable
Cable type	H05Z1Z1-F 2x1.5
Protection type	IP20; IP40 when mated

## Plug-in connection

Mismating protection	Yes
Note on mismating protection	All <i>WINSTA</i> ® components are 100% protected against mismating when: a.) plugging different numbers of poles b.) plugging while rotated 180 c.) plugging while laterally staggered d.) plugging one pole
Locking lever	Can be retrofitted
Locking of plug-in connection	Locking lever
Note on locking system	All connectors for mounted installations (snap-in versions for lighting fixtures or devices, all types of PCB and distribution connectors) are factory-equipped with locking levers to ensure plugs and sockets are securely locked. Additional locking levers are only required for flying leads (plug/socket).

### Material data

Note (material data)	<a href="#">Information on material specifications can be found here</a>
Color	blue
Insulation material (main housing)	Polyamide (PA66)
Flammability class per UL94	V0
Fire class per EN 50575	B2 <sub>ca</sub>
Contact material	Copper or copper alloy; surface-treated
Contact Plating	Tin
Fire load	0.155 MJ
Connector color	blue
Strain relief color	black
Sheathed cable color	black
Printing color of sheathed cable	white
Halogen-free	Yes
Silicon-free	Yes
Sheath material	Halogen-free
Rubber cable	No
Weight	244.4 g
Copper weight of the raw cable	0.029 kg/m

### Environmental requirements

Processing temperature	-5 ... +40 °C
Continuous operating temperature	-35 ... +85 °C
Note on continuous operating temperature	Cable for temperatures ≤ 70 °C (including halogen-free) Insulating parts for temperatures ≤ 105 °C

### Commercial data

PU (SPU)	1 pcs
Packaging type	unpacked
Country of origin	PL
GTIN	4055143804639
Customs tariff number	85444290900

### Product Classification

UNSPSC	26121629
eCl@ss 10.0	27-44-06-04
eCl@ss 9.0	27-44-06-04
ETIM 9.0	EC002587
ETIM 10.0	EC002587
ECCN	NO US CLASSIFICATION

### Environmental Product Compliance

RoHS Compliance Status	Compliant, No Exemption
------------------------	-------------------------

## Downloads

### Environmental Product Compliance

#### Compliance Search

Environmental Product  
Compliance  
891-8282/216-301



## 1 Compatible Products

### 1.1 Required Accessories

#### 1.1.1 Locking system

##### 1.1.1.1 Locking system



[Item No.: 890-111](#)

Locking lever; for flying leads; for tool operation; black



[Item No.: 890-131](#)

Locking lever; for flying leads; for tool operation; white



[Item No.: 890-101](#)

Locking lever; for manual operation; black



[Item No.: 890-121](#)

Locking lever; for manual operation; white

### 1.2 Optional Accessories

#### 1.2.1 Cover

##### 1.2.1.1 Cover



[Item No.: 897-2001](#)

Protective cap; Type1; for sockets and plugs; PVC; red

#### 1.2.2 Installation

##### 1.2.2.1 Mounting accessories



[Item No.: 890-310](#)

Mounting carrier; 2- to 5-pole; for flying leads; black



[Item No.: 890-311](#)

Mounting carrier; 2- to 5-pole; for flying leads; white