

Pressure sensor, digital VAV controller and damper actuator as communicative compact solution for pressure-independent VAV and CAV systems in the comfort zone

- Control modulating, communicative, hybrid
- Conversion of sensor signals
- Communication via BACnet MS/TP, Modbus RTU, Belimo-MP-Bus or conventional control
- Service socket for operating devices

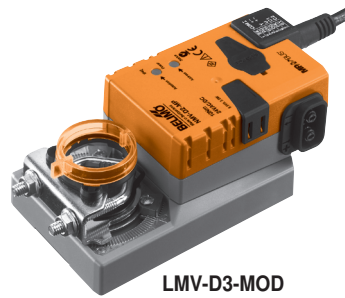

LMV-D3-MOD  
NMV-D3-MOD

**Brief description**

<b>Application</b>	The VAV-Compact with its PI control characteristic is used for the pressure-independent control of VAV units in the comfort zone.
<b>Volumetric flow measurement</b>	The integrated D3 differential pressure sensor is also suitable for very small volumetric flows. The maintenance-free sensor technology enables a wide range of applications in the comfort zone: residential construction, office, hospital, hotel, cruise ship, etc.
<b>Actuator</b>	A variety of actuator versions (5 or 10 Nm) are available to the VAV unit manufacturer for the different VAV unit designs.
<b>Control function</b>	Volumetric flow (VAV/CAV) or position control (Open Loop) for integration in external VAV control loop.
<b>VAV (VVS) – Variable volumetric flow</b>	Demand-dependent specification of the volumetric flow $V'_{min} \dots V'_{max}$ via modulating reference variable via Modbus, e.g. room temperature/CO2 controller, DDC or bus system, for energy-saving air conditioning of individual rooms or zones.
<b>DCV – Demand Controlled Ventilation</b>	In higher-level BACnet/Modbus system, e.g. with integrated Optimiser function.
<b>Mode of operation</b>	The actuator is fitted with an integrated interface for BACnet MS/TP, Modbus RTU and MP-Bus. It receives the digital control signal from the control system and returns the current status.
<b>Converter for sensors</b>	Connection option for a sensor (active or with switching contact). In this way, the analogue sensor signal can be easily digitised and transferred to the bus systems: BACnet, Modbus or MP-Bus.
<b>Parametrisation</b>	The factory settings cover the most common applications. As desired, individual parameters can be adapted for specific systems or servicing with a service tool (e.g. ZTH EU).
<b>Communication parameters</b>	The bus systems communication parameters (address, baud rate, etc-) are set with the ZTH EU. Pressing the "Address" button while connecting the supply voltage resets the communication parameters to the factory setting. Fast addressing: Alternatively, the BACnet/Modbus address can be set with the buttons in area 1 to 16. The value selected is added to the "Basic address" parameter and produces the effective BACnet/Modbus address.
<b>Combination analogue - communicative (hybrid mode)</b>	With conventional control with an analogue control signal, BACnet or Modbus can be used for the communicative position feedback.
<b>Operating and service devices</b>	Service tool ZTH EU, PC-Tool service socket: Local plug-in or via PP connection.
<b>Electrical connection</b>	The connection is made using the integrated connecting cable.
<b>Sales, assembly and setting</b>	The VAV-Compact is mounted by the VAV unit manufacturer (OEM), and the application is adjusted and calibrated accordingly. The VAV-Compact is sold exclusively via the OEM channel for this reason.

Type overview	Type	Torque	Power consumption	For wire sizing	Weight
	LMV-D3-MOD	5 Nm	2 W	4 VA (max. 8 A @ 5 ms)	Approx. 500 g
	NMV-D3-MOD	10 Nm	3 W	5 VA (max. 8 A @ 5 ms)	Approx. 700 g

**Other versions** The VAV-Compact is also available with built-in interface for direct integration in MP-Bus systems and KNX.  
For more information and documentation, see [www.belimo.com](http://www.belimo.com).

Safety Notes



- The device is not allowed to be used outside the specified field of application, especially not in aircraft or in any other airborne means of transport.
- Outdoor applications: Only possible if no (sea) water, snow, ice, solar radiation or aggressive gases act directly on the actuator and it is guaranteed that the ambient conditions are always within the limit values according to the data sheet.
- Only authorised specialists may carry out installation. All applicable legal and government agency regulations must be complied with during use.
- The device may be opened only at the manufacturer's plant. It does not contain any parts that can be replaced or repaired by the user.
- Cables must not be removed from the device.
- When calculating the torque requirement, the specifications supplied by the damper manufacturers (cross-section, construction, installation situation), and the ventilation conditions must be observed.
- The device contains electrical and electronic components and is not permitted to be disposed of as household waste. Local and currently valid legislation must be observed.

Electrical installation

Notes

- Supply via safety isolating transformer!
- Modbus signal assignment:  
C<sub>1</sub> = D- = A  
C<sub>2</sub> = D+ = B
- Supply and communication are not galvanically isolated.
- Connect earth signal for devices with one another.

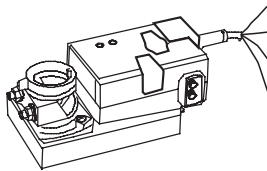

No.	Designation	Cable colour	Function
1	⊥ -	black	} AC/DC 24 V supply
2	~ +	red	
3			
5	▶ MP	orange	MP connection
6	D-	pink	} BACnet / Modbus (RS485)
7	D+	grey	

See separate documentation for description of function and application

### Technical data

<b>Electrical data</b>	Nominal voltage	AC/DC 24 V, 50/60 Hz
	Operating range	AC 19.2...28.8 V / DC 21.6...28.8 V
	Performance data	See type overview (page 1)
	Connection	Cable, 6 x 0.75 mm <sup>2</sup> , pre-fabricated
<b>Volumetric flow controller</b>	Control function	VAV/CAV and position control (Open Loop)
	$V'_{nom}$ <sup>1)</sup>	Nominal flow rate setting OEM-specific, matches the VAV unit
	$\Delta p @ V'_{nom}$ <sup>1)</sup>	38...450 Pa
	$V'_{max}$	20...100% of $V'_{nom}$ , adjustable
	$V'_{mid}$	$>V'_{min}...<V'_{max}$ , adjustable
	$V'_{min}$	0...100% of $V'_{nom}$ , adjustable ( $<V'_{max}$ )
<b>Sensor integration</b>	Input	0...32 V, input impedance 100 k $\Omega$
	Sensor	Active sensor (0...10 V) Switching contact (0 / 1) switching capacity 16 mA @ 24 V
<b>Local override control</b>	Override	CLOSE / $V'_{max}$ / OPEN, AC 24 V supply required
<b>Control communicative</b>	BACnet MS/TP	
	Modbus RTU	(Ex-works)
	MP-Bus	
<b>Operation and service</b>	Service Tool ZTH EU, PC-Tool	Local connector socket / Remote via PP connection
	LED	Supply, status and communication display
	push-button	Addressing, angle-of-rotation adaptation and test function
<b>Actuator</b>	Rotary/Linear version	Brushless, blockage-proof actuator with power-save mode
	Direction of rotation <sup>1)</sup>	Left/right
	Angle of rotation	95°, adjustable mechanical or electrical limitation
	Gear disengaged	Push button, self-resetting without functional limitation
	Position indication	Mechanical or for read-out (Tool, Bus Client)
	Shaft holder	Shaft clamp for round and square axes
<b>Volumetric flow measurement</b>	Differential pressure sensor	Belimo D3 sensor, dynamic measurement principle
	Measurement, nominal voltage range	-20...500 Pa, 0...500 Pa
	Overload capacity	$\pm 3000$ Pa
	Altitude compensation	Adaptation to system altitude (adjustment range 0...3000 meters above sea level)
	Installation position	Position-independent, no reset necessary
	Materials in contact with measuring materials	Glass, epoxy resin, PA, TPE
	Condition of measuring air	Comfort zone 0...50°C / 5...95% RH, non-condensing
<b>Security</b>	Protection class IEC/EN	III Protective extra low voltage (PELV)
	Degree of protection IEC/EN	IP54
	EMC	CE according to 2014/30/EU
	Certification IEC/EN	IEC/EN 60730-1 and IEC/EN 60730-2-14
	Rated impulse voltage	0.8 kV
	Supply / Control	
	Control pollution degree	3
	Ambient temperature	0...50°C
	Storage temperature	-20...80°C
	Ambient humidity	95% RH, non-condensing
	Maintenance	Maintenance-free. Depending on use, the differential pressure pickup device (measuring cross, disc, etc.) of the VAV unit must be checked now and then and cleaned as needed.

<sup>1)</sup> Setting by VAV manufacturer (OEM)

Electrical installation



- Notes**
- Connection via isolating transformer.
  - The wiring of the line for BACnet (MS/TP) and Modbus (RTU) must be carried out according to the relevant RS485 guidelines.
  - BACnet/Modbus: Supply and communication are not galvanically separated. Connect earth signal for devices with one another.

BACnet MS/TP / Modbus RTU

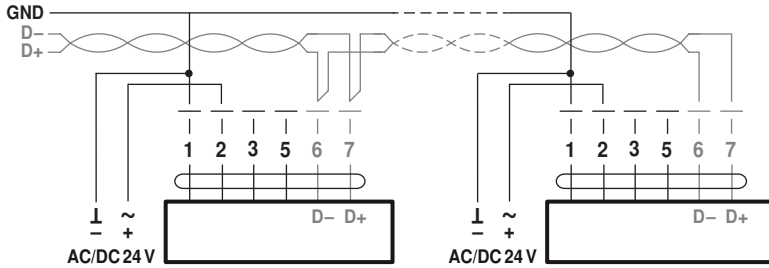

**Cable colour:**

- 1 = black
- 2 = red
- 3 = white
- 5 = orange
- 6 = pink
- 7 = grey

**Modbus signal assignment:**

- C<sub>1</sub> = D- = A
- C<sub>2</sub> = D+ = B

Connection with switching contact, e.g. Δp-monitor

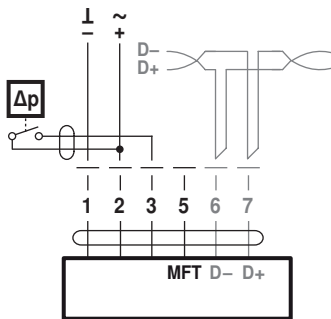

Switching contact requirements:  
The switching contact must be able to switch a current of 16 mA at 24 V accurately.

Connection with active sensor, e.g. 0...10 V @ 0...50 °C

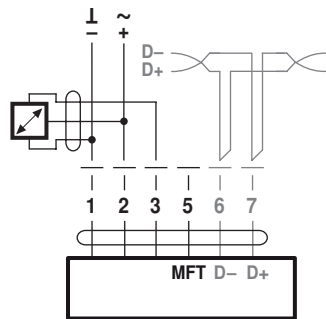

Possible input voltage range:  
0...32 V (resolution 30 mV)

BACnet MS/TP / Modbus RTU with analogue setpoint (hybrid operation)

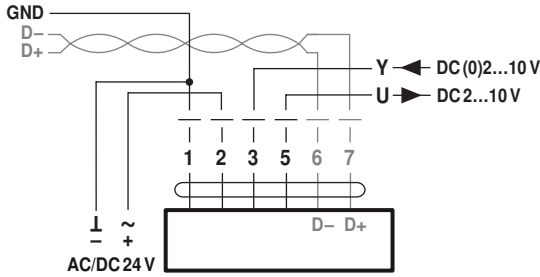

Operation on the MP-Bus

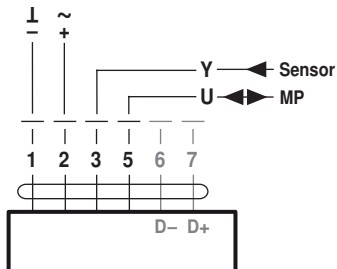

Electrical installation

Local override control

If no sensor is integrated, then connection 3 (Y) is available as the protective circuit for a local override control.

Options: CLOSE –  $V'_{max}$  – OPEN

Caution: Functions only with AC 24 V supply!

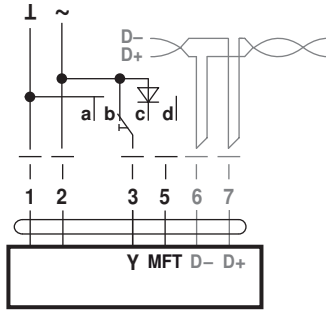

- a Damper CLOSE
- b  $V'_{max}$
- c Damper OPEN
- d Bus mode

Control functions - VAV/CAV

VAV operating volumetric flow - Setting and control

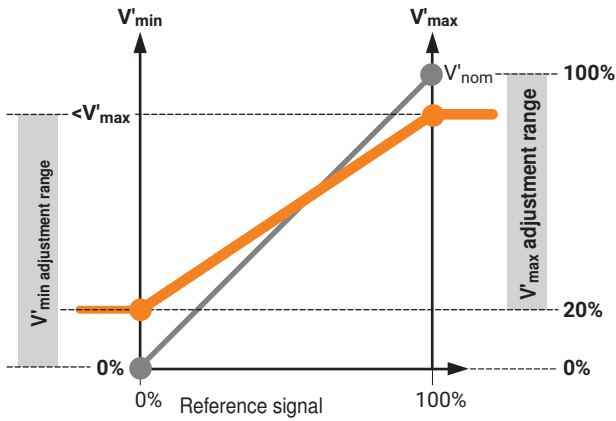

Open Loop (separate external VAV control)

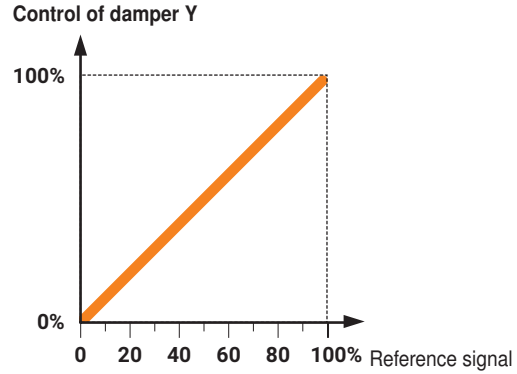

Settings and tool functions

Designation	Setting values, limits, explanations	Units	Tools <sup>6)</sup>		Remarks
			ZTH EU	PC-Tool	
<b>System-specific data</b>					
Position	16 characters, e.g. Office 4 6th OG ZL	Text	r	r/w	
Designation	16 characters: Unit designation, etc.	Text	r	r/w	
Modbus address	1...247 Baud rate etc.		r/w	-	Modbus addressing
Address (MP)	PP		r/w	r/w	For Modbus applications: PP
V'max	20...100% [V'nom]	m <sup>3</sup> /h / l/s / cfm	r/w	r/w	>/= V'min
V'mid	V'min...V'max	m <sup>3</sup> /h / l/s / cfm	r/w	r/w	
V'min	0...100% [V'nom]	m <sup>3</sup> /h / l/s / cfm	r/w	r/w	</= V'max
Altitude of installation	0...3000	Meter	r/w	r/w	Adaptation of Δp sensor to altitude (meters above sea level)
<b>Controller Settings</b>					
Control function	Volumetric flow / Position control (Open Loop)		-	-	
Mode	0...10 / 2...10	Volt	r/w <sup>2)</sup>	r/w	For Modbus applications: 2...10
CAV function <sup>3)</sup>	CLOSE/V'min/V'max; Shut-off level CLOSE 0.1 CLOSE/V'min/V'max; Shut-off level CLOSE 0.5 V'min/V'mid/V'max; (NMV-D2M-comp.)		-	r/w	Not relevant for Modbus applications
Positioning signal Y	Start value: 0.6...30; Stop value: 2.6...32	Volt	r	r/w	Not relevant for Modbus applications
Feedback U	Volume / Damper position / Δp		-	r/w	Not relevant for Modbus applications
Feedback U	Start value: 0.0...8.0; Stop value: 2.0...10	Volt	-	r/w	Not relevant for Modbus applications
Behaviour when switched on (Power-on) <sup>5)</sup>	No action / Adaptation / Synchronisation		-	r/w	
Synchronisation behaviour	Y=0% Y=100%		-	r/w	Synchronisation at damper position 0 or 100%
Bus fail position	Last setpoint / Damper CLOSE V'min / V'max / Damper OPEN		-	r/w	
<b>Unit-specific settings</b>					
V'nom	0...60000 m <sup>3</sup> /h	m <sup>3</sup> /h / l/s / cfm	r	r/(w) <sup>1)</sup>	Unit-specific setting value
Δp@V'nom	38...450 Pa	Pa	r	r/(w) <sup>1)</sup>	Unit-specific setting value
Print function label			-	w	Incl. customer logo
<b>Other settings</b>					
Direction of rotation (for Y=100%)	cw/ccw		r/w <sup>2)</sup>	r/w	
Range of rotation	Adapted <sup>4)</sup> / programmed 30...95	°	-	r/w	
Torque	100 / 75 / 50 / 25	%		r/w	% of nominal torque
<b>Operating data</b>					
Actual value / Setpoint Damper position		m <sup>3</sup> /h / l/s / cfm Pa/%	r	r Trend	Trend display with print function and data saving to HD
Simulation	Damper OPEN/CLOSE V'min / V'mid / V'max / Motor Stop		w	w	
Running times	Operating time, running time Ratio (relation)	h %	-	r	
Alarm messages	Setting range enlarged, Mech. overload, Stop&Go ratio too high		-	r/w	
Serial number	Device ID		r	r	Incl. production date
Type	Type designation		r	r	
Version display	Firmware, Config. table ID		r	r	
<b>Configuration data</b>					
Print, send			-	yes	
Backup in file			-	yes	
<b>Log data / Logbook</b>	Activities log		-	yes	Incl. complete setting data

Explanations

- 1) Write function accessible only for VAV manufacturers
- 2) Access only via Servicing level 2
- 3) CAV setting for MP/MF type
- 4) Within the mechanical limitation
- 4) The first time the supply voltage is switched on, i.e. at the time of initial commissioning, the actuator carries out an adaption, which is when the operating range and position feedback adjust themselves to the mechanical setting range. The actuator then moves into the required position in order to ensure the volumetric flow defined by the control signal.
- 5) For function and version overview, see [www.belimo.com](http://www.belimo.com).

Display and operation

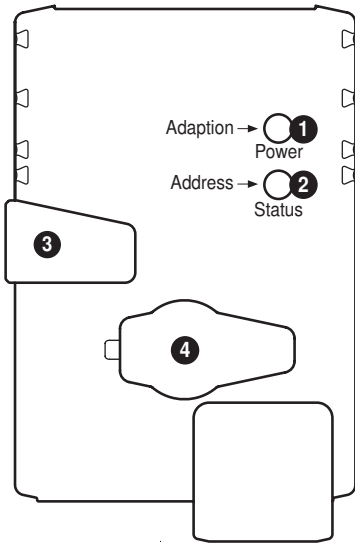

- 1 Push-button and LED display green**  
 Off: No power supply or fault  
 On: Operation  
 Flashing: In address mode: Pulses corresponding to the set address (1...16) When starting: Reset to factory setting (communication)  
 Press button: In standard mode: Switches on angle-of-rotation adaptation  
 In address mode: Confirmation of set address (1...16)
- 2 Push-button and LED display yellow**  
 Off: Standard mode  
 On: Adaptation or synchronising process active  
 Or actuator in address mode (LED display flashing green)  
 Flickering: BACnet/Modbus communication active  
 Press button: In operation (>3 s): Switch address mode on and off  
 In address mode: Address setting by pressing several times  
 When starting (>5 s): Reset to factory setting (Communication)
- 3 Gear disengagement button**  
 Press button: Gear disengaged, motor stops, manual override possible  
 Release button: Gear engaged, synchronisation starts, followed by standard mode
- 4 Service plug**  
 For connecting the parametrisation and service tools

Check power supply connection

- 1** Off and **2** On Possible wiring fault on power supply

Fast addressing Modbus

1. Press the "Address" button until the green "Power" LED display is no longer illuminated. The green "Adaption" LED display flashes in accordance with the previously set address.
  2. Set the address by pressing the "Address" button the corresponding number of times (1...16).
  3. The green LED display flashes in accordance with the address that has been entered (1...16). If the address is not correct, then this can be reset in accordance with Step 2.
  4. Confirm the address setting by pressing the green "Adaption" button.
- If no confirmation occurs for 60 seconds, then the address procedure is ended. Any address change that has already been started will be discarded.  
 The resulting BACnet MS/TP and Modbus RTU address is made up of the set basic address plus the short address (e.g. 100+7=107).

ZTH EU / PC-Tool - Local service connection

Setting and diagnostics of the VAV-Compact can be carried out quickly and easily with the Belimo PC-Tool or the ZTH EU service tool. When the PC-Tool is used, the ZTH EU acts as the interface converter.

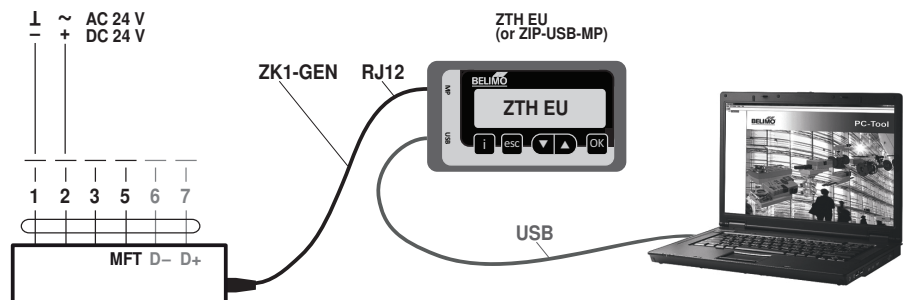

Download PC-Tool (MFT-P)  
from [www.belimo.com](http://www.belimo.com)

Display and operation

ZTH EU/PC-Tool - Remote connection

The VAV-Compacts can communicate with the service tools via the PP connection (wire 5). The connection can be made during operation in the connector socket or at the switchbox terminals. The ZTH EU is used as interface converter with the PC-Tool is used.

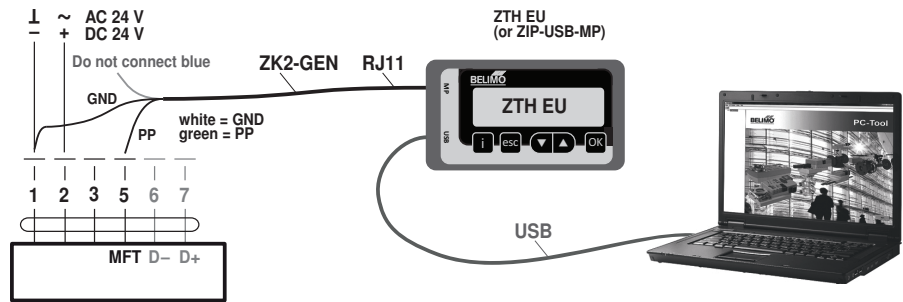

Download PC-Tool (MFT-P)  
from [www.belimo.com](http://www.belimo.com)

Accessories

VAV-Compact / VAV-Universal

Description

VAV-Compact: Version with integrated MP-Bus, LonWorks and KNX interface  
 VAV-Universal: VAV/pressure controllers, Δp sensors, actuators (spring-return, fast running actuator, etc.)  
 For more information and documentation, see [www.belimo.com](http://www.belimo.com)

Electrical accessories

Description

Type

- Connection cable 5 m, to ZTH EU/ZIP-USB-MP (RJ12) with service plug ZK1-GEN
- Connection cable 5 m, to ZTH EU/ZIP-USB-MP (RJ11) with free wire ends ZK2-GEN

Service tools

Description

Type

- Service tool for parametrisable and communicative Belimo actuators / VAV controllers and HVAC control elements ZTH EU
- Belimo PC-Tool, software for adjustments and diagnostics MFT-P
- Adapter for ZTH service tool EU MFT-C

## Dimensions [mm]

Dimensional drawings LMV-D3-MOD

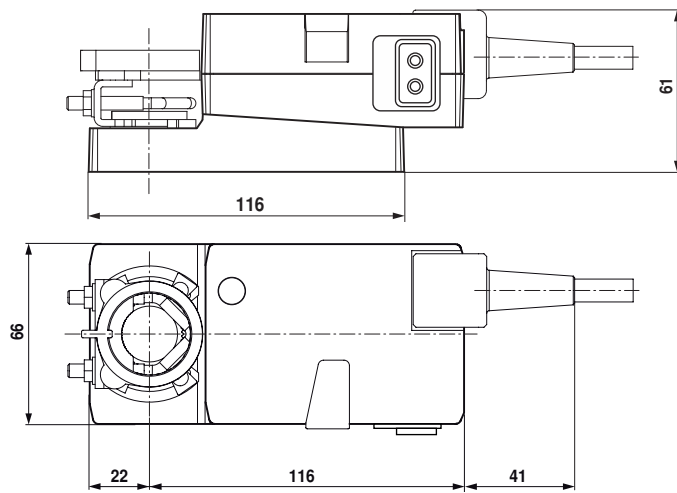

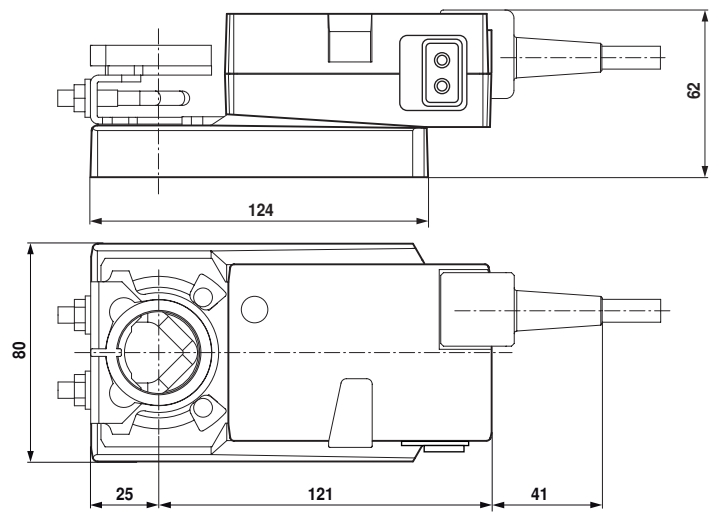

Dimensional drawings NMV-D3-MOD



## Further documentation

- Tool connections
- Description Protocol Implementation Conformance Statement PICS
- Description Modbus register
- Overview MP Cooperation Partners
- MP Glossary
- Introduction to MP-Bus Technology

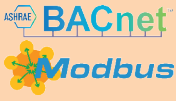
	-MF	-MP	-KNX	-MOD
				
Field of application: Supply air/extract air in the comfort zone and in sensor-compatible media	X	X	X	X
AC/DC 24 V supply	X	X	X	X
$\Delta p$ Sensor installed, dynamic D3, measuring range:	-20...500 Pa	-20...500 Pa	-20...500 Pa	-20...500 Pa
Actuator variants:				
- Rotary actuator	5 / 10 Nm	5 / 10 / 20 Nm	5 / 10 / 20* Nm	5 / 10 / 20* Nm
- Linear actuator	-	150 / 200 / 300 mm	150* / 200* / 300* mm	150* / 200* / 300* mm
VAV-Function Close, $V'_{min} \dots V'_{max}$	X	X	X	X
CAV steps $V'_{min}$ / $V'_{mid}$ / $V'_{max}$ / Close	X	X	-	-
Position Control (Open Loop / External V control)	X	X	X	X
DCV (Optimiser function)	-	DDC MP Partner	Yes, programmable	Yes, programmable
Analogue control	0/2...10 V	0/2...10 V	-	0/2...10 V
Bus actuation	-	X	X	X
Bus specification	-	Belimo MP-Bus	KNX S-Mode	Modbus RTU/ BACnet MS/TP/ RS485
Direct integration DDC MP-Partner	-	X	-	-
Integration via Gateway	-		-	-
- BACnet		X		
- KNX		X		
- Modbus RTU		X		
Number of bus subscribers	-	8 per string	64 per line segment	32 per string
Sensor integration	-			
- Passive (resistance)		X	-	-
- Active (0...10 V)		X	X	X
- Switching contact		X	X	X
Optional control function	-	-	-	-
Local override	-	CLOSE / $V'_{max}$ / OPEN	CLOSE / $V'_{max}$ / OPEN	CLOSE / $V'_{max}$ / OPEN
Aids	-	MP-Bus tester MP monitor	ETS Product database	-
Integration tool	PC-Tool	PC-Tool	ETS	...
TypeList function (Retrofit, OEM)	-	X	(-)	(-)
Tool connection (U – PP/MP)	PP	PP/MP	PP	PP
Service socket ZTH EU/PC-Tool	X	X	X	X
NFC interface	-	X	-	-
Assistant app	-	X	-	-
Service tool ZTH EU	X	X	X	X
PC-Tool	X	X	X	X
- Parameters				
- Save data				
- Trend, Logbook				
- Label print				

\* on request