

HEAT SINK INSTRUCTION MANUAL 077.03



SCREW TERMINALS

⊕ 1...1.3 Nm

TYPE

77.D1

77.F1

77.G1

77.H1

77.A2

77.C2

77.E2

77.A3

77.B3

77.D3

77.F3

THERMAL GREASE
OR THERMAL PAD

077.T1

077.T2

077.T3

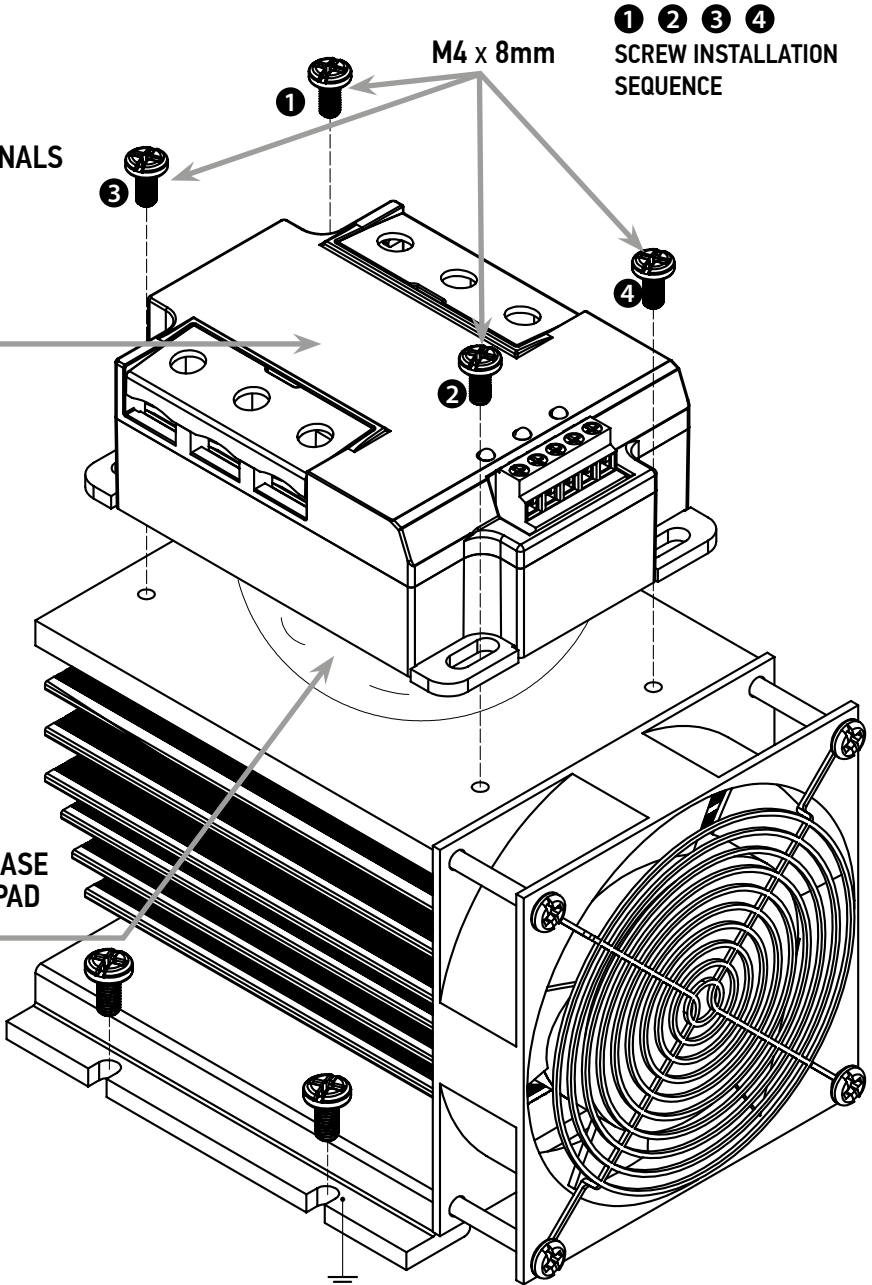

1 2 3 4
SCREW INSTALLATION
SEQUENCE

M4 x 8mm