

Data Sheet | Item Number: 771-9373/266-505

pre-assembled connecting cable; Cca; Plug/open-ended; 3-pole; Cod. S; H05Z1Z1-F 3x1,5 mm²; 5 m; 1,50 mm²; brown

<https://www.wago.com/771-9373/266-505>

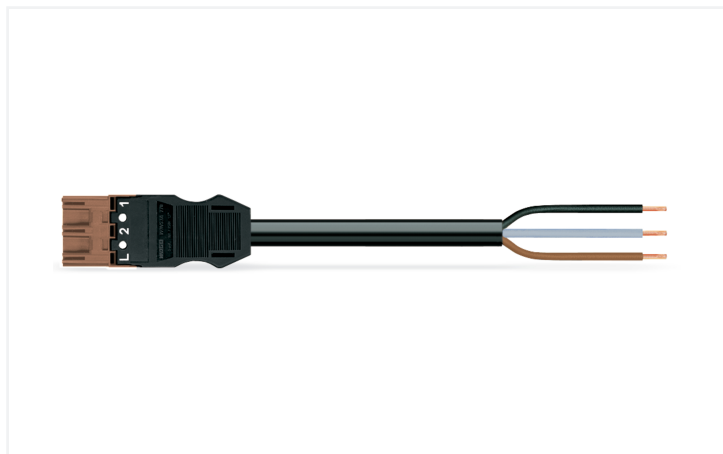

Color: ■ brown

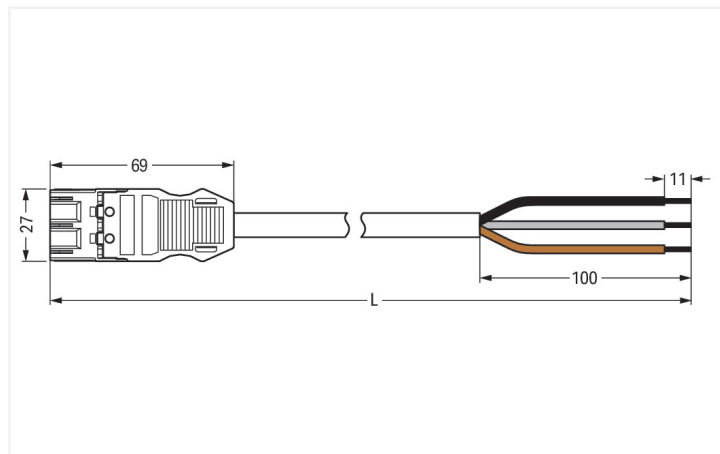

Dimensions in mm

Cable assembly WINSTA® MIDI with strain relief

For power and signal transmission: The WINSTA® MIDI cable assembly 3-pole. The pluggable installation connectors with spring pressure connection technology work entirely without screw connections. They allow fast, efficient, error-free installation in a large number of applications. The coding options reduce installation errors, allowing fast, secure wiring of all components. The pluggable installation connector is protected against ingress by solid objects in accordance with protection type IP20 (When mated: IP2xC (These compact connectors are not designed for use in open, easily accessible areas!)). WINSTA® MIDI pluggable installation connectors with S coding in brown are mainly used in AC systems. The WINSTA® MIDI Pluggable Connection System with Push-in CAGE CLAMP® spring pressure connection technology facilitates precise electrification. Due to the integrated test slot, connections can be checked even when they are plugged in. That saves time and reduces installation labor and costs. Scrupulous compliance with fire protection regulations is an important issue for building installation. Especially in sensitive areas, the fire class must meet or even exceed legal requirements. This product complies with the requirements of fire class C. Eliminating halogens as an additive in the manufacture of this cable assembly significantly improves fire safety and minimises environmental pollution.

Fast, error-free assembly thanks to cable assemblies from WAGO

The cable assembly is provided with a plug and a free end. WINSTA® is the pluggable connection system that is optimally tailored to the strict requirements of electrical installation. It ensures fast, secure and, above all, error-free installation of components and cables. Take advantage of the pluggable version of our maintenance-free spring pressure connection technology too! Plan your installation with with protection type IP20 from WAGO.

- pluggable installation connectors with protection against mismatching
- simple circuits
- with S coding for use in components such as motors or frequency converters
- flexible installation to save space
- convenient installation and commissioning

Notes

Note

Cables with a different fire class can be found in the eShop.

Electrical data

Ratings per	IEC/EN 60664-1		
Overvoltage category	III	III	II
Pollution degree	3	2	2
Nominal voltage	250 V	-	-
Rated impulse withstand voltage	4 kV	-	-
Rated current	16 A	-	-

General information

Note on contact resistance	approx. 1 mΩ of contact resistance approx. 0.25 mΩ contact transition plug/ socket
----------------------------	--

Connection Data

Total number of potentials	3
Conductor preparation	ultrasonically tip-bonded

Connection 1

Strip length	11 mm / 0.43 inches
Pole number	3
Wire cross-section	1.5 mm ²
Strip length (outer insulation)	100 mm
Connection type	Plug - free end

Physical data

Pin spacing	10 mm / 0.394 inches
Width	27 mm / 1.063 inches
Height	12.9 mm / 0.508 inches
Total length	5 m

Mechanical data

Use	Switching function
Coding	S
Variable coding	No
Marking	1 2 L
Potential marking	1 2 L
Mating force of a plug-in connection	approx. 20 ... 70 N (depending on pole number)
Retention force of a plug-in connection	when locked: > 80N
Unmating force of a plug-in connection	when unlocked: approx. 20 ... 70 N (depending on pole number)
Number of mating cycles	200, without resistive load
Connection type	Plug - free end
Type of pre-assembled cable	Connecting cable
Cable type	H05Z1Z1-F 3x1.5
Protection type	IP20; When mated: IP2xC (These compact connectors are not designed for use in open, easily accessible areas!)

Plug-in connection

Mismating protection	Yes
Note on mismating protection	All <i>WINSTA</i> [®] components are 100% protected against mismating when: a.) plugging different numbers of poles b.) plugging while rotated 180 c.) plugging while laterally staggered d.) plugging one pole
Locking lever	Can be retrofitted
Locking of plug-in connection	Locking lever
Note on locking system	All connectors for mounted installations (snap-in versions for lighting fixtures or devices, all types of PCB and distribution connectors) are factory-equipped with locking levers to ensure plugs and sockets are securely locked. Additional locking levers are only required for flying leads (plug/socket).

Material data

Note (material data)	Information on material specifications can be found here
Color	brown
Insulation material (main housing)	Polyamide (PA66)
Flammability class per UL94	V0
Fire class per EN 50575	C _{ca}
Contact material	Copper or copper alloy; surface-treated
Contact Plating	Tin
Fire load	0.323 MJ
Connector color	brown
Strain relief color	black
Printing color of strain relief	white
Sheathed cable color	black
Printing color of sheathed cable	white
Halogen-free	Yes
Silicon-free	Yes
Sheath material	Halogen-free
Rubber cable	No
Weight	514.6 g
Copper weight of the raw cable	0.043 kg/m

Environmental requirements

Processing temperature	-5 ... +40 °C
Continuous operating temperature	-35 ... +85 °C
Note on continuous operating temperature	Cable for temperatures ≤ 70 °C (including halogen-free) Insulating parts for temperatures ≤ 105 °C

Commercial data

PU (SPU)	1 pcs
Packaging type	unpacked
Country of origin	DE
GTIN	4055143776271
Customs tariff number	85444290900

Product Classification

UNSPSC	26121629
eCl@ss 10.0	27-44-06-04
eCl@ss 9.0	27-44-06-04
ETIM 9.0	EC002587
ETIM 10.0	EC002587
ECCN	NO US CLASSIFICATION

Environmental Product Compliance

RoHS Compliance Status	Compliant, No Exemption
------------------------	-------------------------

Downloads

Environmental Product Compliance

Compliance Search

Environmental Product Compliance 

771-9373/266-505

1 Compatible Products

1.1 Required Accessories

1.1.1 Locking system

1.1.1.1 Locking system



[Item No.: 770-101](#)
Locking lever; for flying leads; for manual operation; black



[Item No.: 770-121](#)
Locking lever; for flying leads; for manual operation; white



[Item No.: 770-111](#)
Locking lever; for flying leads; for tool operation; black



[Item No.: 770-131](#)
Locking lever; for flying leads; for tool operation; white

1.2 Optional Accessories

1.2.1 Cover

1.2.1.1 Cover



[Item No.: 770-360](#)
Lockout cap; for plugs; 5-pole; separable; yellow



[Item No.: 897-2003](#)
Protective cap; Type2; for sockets and plugs; PVC; red

1.2.2 Installation

1.2.2.1 Mounting accessories



[Item No.: 770-310](#)
Mounting carrier; 2- to 5-pole; for flying leads; black

1.2.3 Marking

1.2.3.1 Marker



[Item No.: 770-450/000-006](#)
Marker card; Plastic; blue



[Item No.: 770-450/000-001](#)
Marker card; Plastic; green



[Item No.: 770-450/000-012](#)
Marker card; Plastic; orange



[Item No.: 770-450/000-005](#)
Marker card; Plastic; red



[Item No.: 770-450](#)
Marker card; Plastic; white



[Item No.: 770-450/000-002](#)
Marker card; Plastic; yellow

1.2.3.2 Marking strip



Item No.: 210-334

Marking strips; as a DIN A4 sheet; Strip width 5 mm; Strip length 182 mm; plain; Self-adhesive; white