



Powering Business Worldwide

Instruction Leaflet  
Montageanweisung  
Notice d'installation

02/89 AWA461-746

## L1-CI43

Devices, hole no. and size of the screws for the devices (M...x...);  
screwhead shape DIN 7985; spring washer DIN 137A

Gerät, Loch-Nr. und Schraubengröße des Gerätes (M...x...); Kopfform DIN 7985;  
Federscheibe DIN 137A

Appareils, no. des trous en taille des vis pour les appareils (M...x...); forme de tête DIN 7985;  
rondelle élastique DIN 137A

Typ

	DIL2(A)M	SDAINL1AM	DIUL1AM	DIUL2AM	DIL3-22	DIL3-22/P1	TC-RMQ	Z4-...	Dd+Kdc+BT451	3D+Kdc	K25/1	K60/1
	M5 x 16	M5 x 12			M5 x 20		M4 x 16	M5 x 20	M5 x 9		M5 x 12	
DIL2(A)M/I	12						3		2			
SDAINL1(A)M/I		1									13	
DIUL1AM//I			11				3,4, 5			6,7, 8		
DIUL2AM//I				10								
DIL3-22/Z4/I					15			14			13, 17	
DIL3-22/G/Z4/I												13
DIL3-22/P1/I						16						
DIL2M+P1DIL2M/I	18											13, 17

Kernlochdurchmesser für  
metrisches Gewinde DIN 13

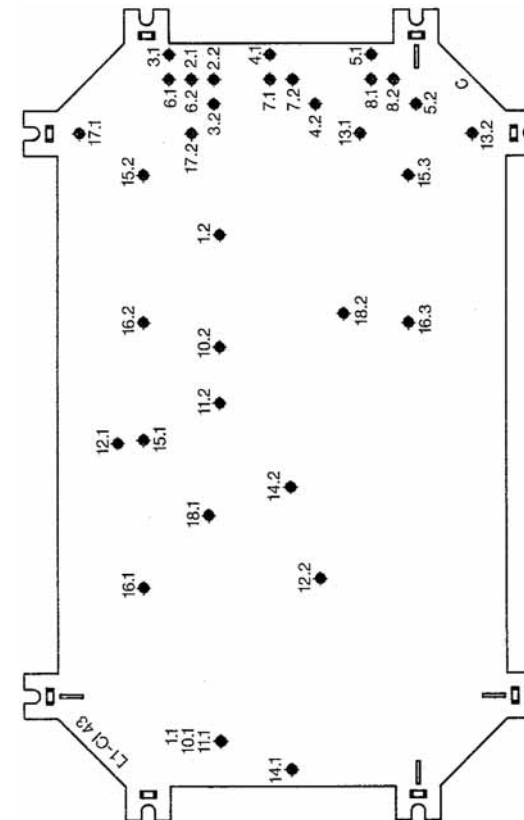

M3-CI...

1

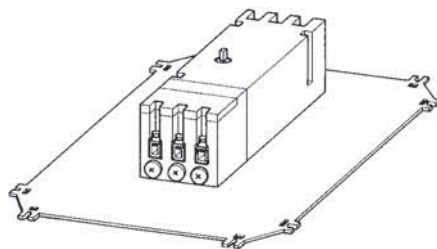

2

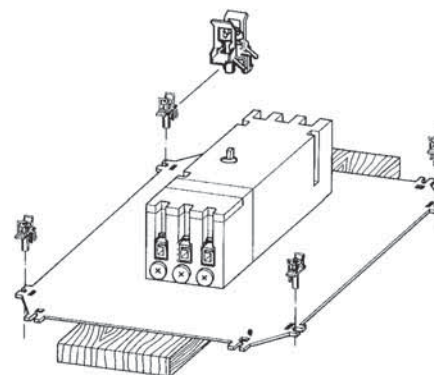

3

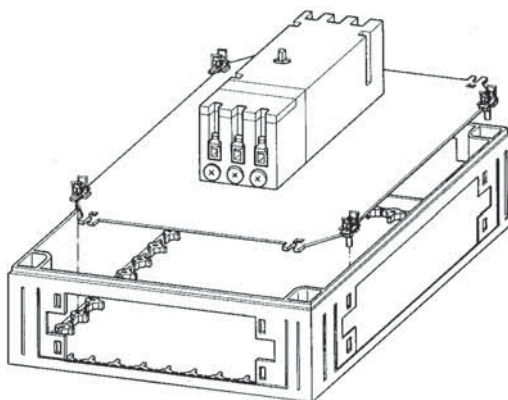

02/89 AWA461-746