

Wilo-DrainLift SANI-M

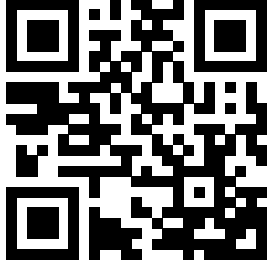

en Installation and operating instructions



DrainLift SANI-M
<https://qr.wilo.com/481>

Table of Contents

1 General	4	8.1 Application limits	24
1.1 About these instructions	4	8.2 During operation	24
1.2 Copyright	4	8.3 Emergency operation	24
1.3 Subject to change	4	9 Shutdown/dismantling	25
1.4 Exclusion from warranty and liability	4	9.1 Staff qualifications	25
2 Safety	4	9.2 Operator responsibilities	25
2.1 Safety signs, instructions, and text markups	4	9.3 Shutdown	25
2.2 Staff qualifications	6	9.4 Removal	26
2.3 Protective equipment for staff	6	9.5 Clean and disinfect	27
2.4 Electrical work	6	10 Maintenance and repair	27
2.5 Monitoring devices	7	10.1 General overhaul	27
2.6 Pumping of fluids that are hazardous to health	7	11 Spare parts	27
2.7 Explosive atmosphere in the collection tank	7	12 Disposal	27
2.8 Transport	8	12.1 Protective clothing	27
2.9 Installing/dismantling	8	12.2 Oils and lubricants	27
2.10 During operation	8	12.3 Information on the collection of used electrical and elec- tronic products	28
2.11 Cleaning and disinfection	9		
2.12 Maintenance tasks	9		
2.13 Operator responsibilities	9		
3 Application/use	9		
3.1 Intended use	9		
3.2 Improper use	10		
4 Product description	10		
4.1 Design	10		
4.2 Materials	11		
4.3 Monitoring devices	11		
4.4 Operating principle	11		
4.5 Operation with frequency converter	11		
4.6 Type key	11		
4.7 Technical data	11		
4.8 Manufacturer date	12		
4.9 Scope of delivery	12		
4.10 Accessories	13		
5 Transportation and storage	13		
5.1 Delivery	13		
5.2 Transport	13		
5.3 Storage	13		
6 Installation and electrical connection	14		
6.1 Staff qualifications	14		
6.2 Installation types	14		
6.3 Operator responsibilities	14		
6.4 Installation	14		
6.5 Electrical connection	20		
7 Commissioning	22		
7.1 Staff qualifications	22		
7.2 Operator responsibilities	22		
7.3 Operation	22		
7.4 Test run	22		
7.5 Follow-up time	23		
7.6 Setting the venting screw	23		
8 Operation	23		

1 General

1.1 About these instructions

These instructions form part of the product. Compliance with the instructions is essential for correct handling and use:

- Before all activities, read the instructions carefully
- Always keep the instructions in an accessible place
- Observe all product specifications
- Observe the markings on the product

The language of the original operating instructions is English. All other languages of these instructions are translations of the original operating instructions.

1.2 Copyright

WILO SE © 2023

The reproduction, distribution, and utilisation of this document and the communication of its contents to others without express consent is prohibited. Infringement results in the obligation to pay for damages. All rights reserved.

1.3 Subject to change

Wilo reserves the right to change the listed data without prior notice and is not liable for technical inaccuracies and/or omissions. The illustrations vary from the original and are intended as a sample representation of the device.

1.4 Exclusion from warranty and liability

Wilo assumes no warranty or liability in the following cases:

- Improper configuration due to insufficient or incorrect instructions by the operator or the client
- Non-compliance with these instructions
- Improper use of the product
- Incorrect storage or transport
- Incorrect installation or dismantling
- Insufficient maintenance
- Unauthorised repairs
- Unsuitable installation location
- Chemical, electrical or electrochemical influences
- Wear of product components

2 Safety

This section contains safety information for the individual phases of the pump's life cycle. Disregarding this information leads to:

- Danger to persons
- Danger to the environment
- Property damage
- Loss of liability claim if damage occurs

2.1 Safety signs, instructions, and text markups

Safety instructions are displayed as follows in these installation and operating instructions:

- Danger to persons: Signal word **with a preceding safety symbol** and shaded grey.
- Property damage: Signal word **without safety symbol**.

Signal words

- **DANGER!**
Disregarding the instructions results in death or serious injury!
- **WARNING!**
Disregarding the instructions leads to (serious) injury!
- **CAUTION!**
Disregarding the instructions leads to property damage or even a total loss.

- **NOTICE!**

Useful information for handling the product.

Text markups

✓ Precondition

1. Work step/list
 - ⇒ Notice/instructions
 - ▶ Result

Cross references

The name of the section or table is in quotation marks [“ ”]. The page number follows in square brackets [].

Overview of used safety symbols



Danger of death due to electric shock



Danger of death due to explosion



Danger due to bacterial infection



Warning – risk due to hot surfaces



Wear protective helmet.



Wear safety shoes.



Wear safety gloves.



Wear respiratory mask.



Wear safety glasses.



Be aware about the instructions.



Useful information

2.2 Staff qualifications

- The staff is informed about the local accident prevention regulations.
- The staff has read and understood the operating instructions.
- Electrical work to be performed by a qualified electrician. A qualified electrician is a person with appropriate technical training, knowledge, and experience who can identify and prevent electrical hazards.
- Installation and dismantling to be performed by a trained expert for sanitary installations, including fastening of buoyancy safeguard and connection of plastic pipes.
- Maintenance to be performed by a trained expert for sanitary installation with knowledge of lifting units according to EN 12056 standard and awareness of the danger of sewage.

The use of the product is prohibited for:

- Persons (incl. children) under the age of 16
- Persons with reduced physical, sensory, or mental capacities

An expert must supervise persons under the age of 21.

2.3 Protective equipment for staff

The specified protective equipment is the minimum requirement. Observe the requirements of the factory regulations.

Protective equipment: transport, installation, removal, and maintenance

- Safety shoes: Protection class S1 (uvex 1 sport S1)
- Safety gloves (EN 388): 4X42C (uvex C500 wet)
- Safety helmet (EN 397): conforms to the standard and protects against lateral deformation
(If lifting accessories are used)

Protective equipment: cleaning work

- Safety gloves (EN ISO 374-1): 4X42C + Type A (uvex protector chemical NK2725B)
- Safety glasses (EN 166): (uvex skyguard NT)
 - Marking of frame: W 166 34 F CE
 - Marking of eyeglass-lens: 0-0.0* W1 FKN CE
 - * Protection level according to EN 170 not relevant for this work.
- Respiratory mask (EN 149): Half mask 3M series 6000 with filter 6055 A2

Article recommendations

The mentioned branded articles are non-binding suggestions. Similar products from other brands can also be used. The prerequisite is the fulfilment of the mentioned standards.

WILO SE accepts no liability for the mentioned articles regarding their conformity to the relevant standards.

2.4 Electrical work

- Any electrical work must be performed by a qualified electrician.

- Ensure the product is disconnected from the mains connection. Secure the product against unauthorised restarting.
- The mains connection complies with the local regulations.
- The mains connection complies with the specifications of the local energy supplier.
- The staff is informed about the electrical connection.
- The staff is informed about the shutdown options for the device.
- Observe the technical data on the rating plate and in these installation and operating instructions.
- Earth the product.
- Install the switchgear, that the switchgear is protected from flooding.
- Replace damaged cables. In this case, contact customer service.

2.5 Monitoring devices

Provide the following monitoring devices on-site:

Circuit breaker

- Type and switching characteristics of the circuit breakers must conform to the rated current of the connected product.
- Observe local regulations.

Residual-current device (RCD)

- Install a residual-current device (RCD) according to the regulations of the local energy supplier.
- If persons can come into contact with the device and conductive fluids, install a residual-current device (RCD).

2.6 Pumping of fluids that are hazardous to health

There is a risk of bacterial infection if you come into contact with the fluid inside the lifting unit.

- Wear protective equipment.
- Clean and disinfect the tank during removal.
- Inform all persons about the pumped fluid and the danger it poses.

2.7 Explosive atmosphere in the collection tank

Sewage containing faeces can lead to gas accumulations in the tank. These gas accumulations can escape into the operating space due to improper installation or maintenance work. An explosive atmosphere can form. This atmosphere can ignite and lead to an explosion. To avoid an explosive atmosphere, note the following points:

- Only use undamaged tanks (no cracks, leaks, porous material). Switch off lifting units with damaged tanks immediately.
- Ensure that all connections for the inlet, discharge pipe, and ventilation are sealed tightly and executed according to the local regulations.

- Route the ventilation pipe via the roof of the building. For the correct length of the pipe above the roof, observe your local regulations.
- If you open the tank (e.g. during maintenance work), ensure the operating space is well ventilated.

2.8 Transport

- Observe on-site local regulations and laws on accident prevention and work safety.
- Transport the product by the grip strap at the tank.
- Transport the product with two persons.

Packaging requirements

- Shock resistant
- Moisture resistant
- Proper and secure fastening
- Protection against dirt, dust, and oil

2.9 Installing/dismantling

- Observe on-site local regulations and laws on accident prevention and work safety.
- Ensure the product is disconnected from the mains connection. Secure the product against unauthorised restarting.
- When dismantling, shut off inlet and discharge pipe.
- Ventilate closed rooms.
- Working alone in closed rooms is prohibited. A second person must be present.
- Toxic or asphyxiating gases can build up in closed rooms or buildings. Wear protective equipment (e.g., gas detector) according to the factory regulations.
- Clean the product thoroughly.

Risk of fire! Static charging can occur when cleaning plastic parts. Only wear anti-static clothing. Do not use highly flammable cleaning agents.

2.10 During operation

- Open all shut-off valves in the inlet and discharge pipe.
- The maximum inflow must be lower than the maximum output of the system.
- Do not open the inspection opening.
- Ensure the operating space is well ventilated.

CAUTION

Avoid overpressure in the collection tank!

If it comes to an overpressure in the tank, the tank may burst. To avoid overpressure, note the following points:

- Max. inlet height of the lowest inlet is 5 m (16.5 ft)!
- The max. inflow must be lower than the max. volume flow at the duty point!
- Max. pressure in the discharge pipe: 6 bar (87 psi)
- Fluid temperature: 3 ... 40 °C (37 ... 104 °F), max. 65 °C (149 °F) for 5 min
- Ambient temperature: 3 ... 40 °C (37 ... 104 °F)

2.11 Cleaning and disinfection

- If you use a disinfectant, wear protective equipment according to the manufacturer's instructions.
- Instruct all persons involved about the disinfectant and its correct use.

2.12 Maintenance tasks

- Any maintenance work must be performed by a (trained) expert for lifting units with knowledge of sanitary installations.
- Ensure the product is disconnected from the mains connection. Secure the product against unauthorised restarting.
- Clean the product thoroughly.

Risk of fire! Static charging can occur when cleaning plastic parts. Only wear anti-static clothing. Do not use highly flammable cleaning agents.
- When dismantling, shut off inlet and discharge pipe.
- Only use original parts from the manufacturer. Using non-original parts releases the manufacturer from any liability.
- Immediately clean up and remove leaked liquids (fluid, operating fluid). Dispose of the liquids according to the local regulations.

2.13 Operator responsibilities

- Provide installation and operating instructions in the language, which the staff can read and understand.
- Ensure that staff is trained for the specified work.
- Provide protective equipment. Ensure that staff wearing protective equipment.
- Ensure that attached safety and information signs are always clearly legible.
- Instruct staff on how the system operates.
- Mark and block the working area.

3 Application/use

3.1 Intended use

Pumping of sewage containing faeces:

- In cases where sewage cannot be discharged directly into the sewer system via a natural downward slope
- For backflow resistant drainage in cases where the discharge point is below the backflow level

NOTICE! Install grease traps upstream of the lifting unit if pumping greasy sewage!

The version for aggressive fluids (SANI...C) is for pumping:

- Swimming pool water with a max. chloride content of 1.2 mg/l
- Aggressive sewage with a pH value of 5 ... 12:
 - Rainwater (observe local regulations, e.g. DIN 1986-100)
 - Cleaning agents, disinfectants, dishwashing or laundry detergents
 - Condensate from condensing boiler

CAUTION! The fluid in the collection tank must not exceed or fall short of the pH value of 5 ... 12!

3.2 Improper use



DANGER

Explosion hazard due to pumping of explosive fluids!

The lifting unit is not designed for these fluids. There is a danger of death due to explosion!

- Pumping highly flammable and explosive fluids (gasoline, kerosene, ...) is strictly prohibited.
- Do not pump these fluids!

Do **not** use for the following fluids:

- Sewage from discharge points higher than the backflow level which can be discharged directly into the sewer system via a natural downward slope
- Debris, ash, rubbish, glass, sand, plaster, cement, lime, mortar, fibrous materials, textiles, paper towels, wet wipes (e.g. fleece cloths, moist toilet paper wipes), nappies, cardboard, coarse paper, synthetic resins, tar, kitchen waste, grease, oil
- Slaughterhouse waste, disposal of slaughtered animals and animal waste (liquid manure etc.)
- Toxic, aggressive and corrosive fluids, such as heavy metals, biocides, pesticides, acids, bases, salts, swimming pool water
- Cleaning agents, disinfectants, dishwashing or laundry detergents in excess amounts, which have a disproportionately high degree of foam formation
- Drinking water

The intended use entails compliance with these operating instructions. Any other use is not compliant with the intended use.

4 Product description

4.1 Design



Fig. 1: Overview

Ready for connection and fully submersible single pump lifting unit for pumping sewage containing faeces.

1	Collection tank
2	Inspection opening of collection tank
3	Collection tank ventilation connection
4	Discharge port
5	Inspection opening of non-return valve
6	Grip strap
7	Drain connection
8	Motor

Gas- and watertight collection tank with sloped floor at an angle and an inspection opening with transparent cover.

Freely selectable inlets within the marked areas.

Level measurement performed with an analogue output signal 4 ... 20 mA.

Discharge port attached with a non-return valve including an inspection opening.

Surface-cooled (air) or self-cooling (sheath flow cooling) motor with thermal motor monitoring.

Pre-installed switchgears for automatic operation:

Wilo-Control MS-L

- Collective fault signal with potential-free contact
- Integrated and mains-independent alarm

- Adjustable follow-up time
- 1.5 m connection cable with attached plug

Wilo-Control EC-L

- Operation via display and icon-based, alphanumeric menu
- Collective fault signal with potential-free contact
- Individual fault signal with potential-free contact
- ModBus interface
- Integrated and mains-independent alarm
- Adjustable follow-up time

4.2 Materials

- Motor housing: 1.4404 (AISI 316L)
- Hydraulics: PP-GF30
- Impeller: PP-GF30 or 1.4408 (AISI 316)
- Tank: PE
- Non-return valve: PPS

4.3 Monitoring devices

Monitoring of motor winding

The motor is equipped with thermal motor monitoring with bimetallic sensor:

- Single-phase AC motor: The motor monitoring is self-switching. The motor is switched off if it overheats. The motor is automatically switched on again once it has cooled down.
- Three-phase AC motor: The motor monitoring is displayed and reset via the connected switchgear.

High water alarm with collective fault signal

When the high water level is reached, an audible and visual alarm signal is given and the switching on of the pump is automatically initiated. Furthermore, the collective fault signaling contact is activated. An external alarm (horn, SMS via SmartHome connection) can be triggered via the potential-free contact.

If the water drops below the high water level, the pump is deactivated once the follow-up time has elapsed. The alarm signal is acknowledged automatically.

4.4 Operating principle

The sewage is directed into the collection tank via the inlet pipe. When the water level reaches the switch-on level, the pump is switched on. The collected sewage is pumped into the connected discharge pipe. When the switch-off level is reached, the pump is deactivated after the set follow-up time.

When the high water level is reached, the pump is switched on (forced switch-on). The high water LED or display shows an alarm signal. Additionally, the internal buzzer can emit an audible alarm signal. Furthermore, the output for the collective fault signal (SSM) is activated.

4.5 Operation with frequency converter

Operation with the frequency converter is not permitted.

4.6 Type key

Example:	DrainLift SANI-M.13M/4C
DrainLift	Product family
SANI	Sewage lifting unit
M	Size
13	Max. delivery head
M	Mains connection:
	<ul style="list-style-type: none"> • M = 1~ • T = 3~
4	Motor and switchgear version:
	<ul style="list-style-type: none"> • 1 = operating mode: S3, switchgear: Control MS-L • 4 = operating mode: S1, switchgear: Control EC-L
C	Version for aggressive fluids

4.7 Technical data

Approved field of application	
Max. pressure in the discharge pipe	6 bar (87 psi)
Max. delivery head	See rating plate

Max. volume flow	See rating plate
Max inlet height of the lowest inlet	5 m (16.5 ft)
Fluid temperature	3 ... 40 °C (37 ... 104 °F), max. 65 °C (149 °F) for 5 min
Ambient temperature	3 ... 40 °C (37 ... 104 °F)

Motor data

Mains connection	<ul style="list-style-type: none"> SANI-M...M/...: 1~230 V, 50 Hz SANI-M...T/...: 3~400 V, 50 Hz
Power consumption [P_1]	See rating plate
Rated power [P_2]	See rating plate
Rated current [I_N]	See rating plate
Speed [n]	See rating plate
Activation type	Direct
Operating mode	<ul style="list-style-type: none"> SANI-M.../1...: S3 10% <ul style="list-style-type: none"> – Cycle duration: 10 min – Activation period: 1 min – Downtime: 9 min SANI-M.../4...: S1
Protection class	IP68 (2 mWG/7 d)
Cable length to plug	1.5 m (5 ft)
Cable length to switchgear	<ul style="list-style-type: none"> SANI-M.../1...: 4 m (13 ft) SANI-M.../4...: 10 m (33 ft) SANI-M.../4C...: 10 m (33 ft)
Plug	<ul style="list-style-type: none"> Single-phase current: <ul style="list-style-type: none"> – DrainLift SANI-M...M/...: CEE 7/7 (Schuko) Three-phase current: <ul style="list-style-type: none"> – DrainLift SANI-M...T/...: CEE 16A, 3P+N+PE, 6 h, clockwise rotating field

Connections

Discharge port	DN 80, PN 10
Inlet connection	DN 100/150 (110/160 mm)
Collection tank ventilation connection	DN 65 (75 mm)
Drain connection	DN 40 (50 mm)

Dimensions and weights

Tank volume	99 l (26 US.liq.gal.)
Max. usable volume in the tank according to the inlet height*	50 l/13 US.liq.gal. (180 mm*)/63 l/16.5 US.liq.gal. (250 mm*)/74 l/19.5 US.liq.gal. (315 mm*)
Diagonal dimension	850 mm (33.5 in)
Weight	37 ... 51 kg (81.5 ... 112 lb)
Noise level	70 dB(A)

DrainLift SANI-M.../1...:

The unit is not designed for continuous duty! The max. volume flow applies to intermittent periodic duty S3!

DrainLift SANI-M.../4...:

The unit is designed for continuous duty! The max. volume flow applies to continuous duty S1!

4.8 Manufacturer date

The manufacture date is indicated according to ISO 8601: YYYYWww

- YYYY = year
- W = abbreviation for week
- ww = calendar week

4.9 Scope of delivery

- Lifting unit with switchgear and connection cable with plug
- Flange connector DN 80 (90 mm)/DN 100 (110 mm)
- Collar DN 100 (110 mm) for discharge connection

- HT double socket DN 65 (75 mm) for ventilation connection
- HT double socket DN 40 (50 mm) for drain connection
- Inlet set with hole saw 124 mm (5 in) and seal DN 100 (110 mm)
- Floor fixation set
- Noise insulation mat
- 9 V rechargeable battery
- Installation and operating instructions

4.10 Accessories

On the discharge side

- DN 80 flange connector for connection of a DN 80 discharge pipe
- DN 80 flange shut-off valve made of cast material with flat seal and assembly material

On the inlet side

- DN 100/DN 150 shut-off valve made of plastic with fixed pipe ends
- DN 100/DN 150 inlet seals
- DN 100/DN 150 inlet sets (seal and saw)

General

- Diaphragm hand pump with R 1½ connection (without hose)
- 3-way stopcock for switching over to manual suctioning
- Horn 230 V, 50 Hz
- Flash light 230 V, 50 Hz
- Signal lamp 230 V, 50 Hz

5 Transportation and storage

5.1 Delivery

- Immediately check the shipment for defects (damage, completeness ...).
- Note all defects on the freight documentation.
- Inform the manufacturer about the defects on the day upon receipt of the shipment.
- Claims submitted later can no longer be asserted.

5.2 Transport

Only remove the outer packaging at the place of use to ensure that the lifting unit is not damaged during transport. Use tear-proof plastic bags of sufficient size to pack used lifting units for transport in a leak-proof manner.

5.3 Storage



DANGER

Danger due to bacterial infection!

The lifting unit collects and pumps sewage. Bacteria and hazardous germs can form in the tank!

- After removal, disinfect the lifting unit. Especially the inner side of the tank!
- Observe factory regulations!

CAUTION

Total loss due to water ingress in the connection cable!

Water ingress in the cable destroys the connection cable and motor.

- Never immerse the cable end in fluid.
- Close the cable end tightly for storage.

Newly supplied lifting units can be stored for one year. For longer storage periods, contact customer service.

When storing the pump, please note the following points:

- Place the lifting unit securely on a firm surface and secure it against slipping and falling over.
- Permitted storage temperature: -15 ... 60 °C (5 ... 140 °F), max. humidity: 90 %, non-condensing.
We recommend frost-proof storage. Storage temperature: 5 ... 25 °C (41 ... 77 °F), relative humidity: 40 ... 50 %.
- Drain the collection tank completely.

- Coil up connection cables and attach to the motor.
- Seal open ends of the connection cables and plugs in a watertight manner.
- Store switchgear according to the instructions.
- Tightly seal all open connections.
- Do not store the lifting unit in spaces where welding work is carried out. The resulting gases or radiation can corrode the plastic and elastomeric parts.
- Protect the lifting unit from direct sunlight and heat. Extreme heat can cause damage to the plastic parts.
- Elastomeric parts are subject to natural brittleness. Contact customer service if storage is required for more than 6 months.

6 Installation and electrical connection

6.1 Staff qualifications

- Electrical work to be performed by a qualified electrician.
A qualified electrician is a person with appropriate technical training, knowledge, and experience who can identify and prevent electrical hazards.
- Installation and dismantling to be performed by a trained expert for sanitary installations, including fastening of buoyancy safeguard and connection of plastic pipes.

6.2 Installation types

- Floor-mounted installation in buildings
- Concealed floor installation in pump chambers outside of buildings

6.3 Operator responsibilities

- Observe locally applicable accident prevention and safety regulations.
- Observe all regulations for working under suspended loads when using lifting accessories.
- Provide protective equipment. Ensure that the protective equipment is worn by the staff.
- Observe local sewage technology regulations for the operation of sewage systems.
- Structural components and foundations must be sufficiently stable to allow the device to be fixed in a secure and functional manner. The operator is responsible for the provision and suitability of the structural component/foundation.
- Ensure free access to the installation location.
- Perform the installation work according to locally applicable regulations.
- Check that the available consulting documents (installation plans, installation location, inflow conditions) are complete and accurate.
- Lay and prepare the pipes according to the consulting documents.
- Mains connection must be installed so that it is protected from flooding.

6.4 Installation



WARNING

Hand and foot injuries due to lack of protective equipment!



Danger of (serious) injuries during work. Wear the following protective equipment:

- Safety gloves
- Safety shoes



CAUTION

Material damage due to incorrect transport!

It is not possible to transport and to position the lifting unit alone. There is a risk of material damage to the lifting unit! Always transport the lifting unit and align it at the installation location with two persons.

Building installation

- Ensure the operating space is well ventilated.
- Ensure a free space of min. 60 cm (2 ft) around the unit.
- In the event of an accident: Provide pump sump in the operating space, min. dimensions: 500x500x500 mm (20x20x20 in). Select pump accordingly. Ensure that manual drainage is feasible.

- All connection cables must be laid properly. The connection cables must not pose any risk (i.e. tripping, damage during operation). Check whether the cable cross-section and the cable length are sufficient for the selected installation type.
- The mounted switchgear is not protected from flooding. Install the switchgear at an adequate height.

Installation in the pump chamber



DANGER

Risk of injury due to working alone!

Performing work in chambers and narrow rooms as well as in areas with risk of falling can be dangerous. Do not perform this work alone!

- Only perform the work with another person!



WARNING

Head injuries due to lack of protective equipment!

Danger of (serious) injuries during work can occur. If a lifting accessory is used, wear a safety helmet!

CAUTION

Beware of frost!

Frost can cause malfunctions and damage. Pay attention to local frost depths. If the unit or discharge outlet are in the frost zone, stop the operation of the unit during frost periods.

Also adhere to the following points if the lifting unit is installed in a pump chamber:

- Toxic or asphyxiating gases can build up during work.
- If toxic or asphyxiating gases accumulate, leave the workplace immediately.
- Note the diagonal dimension of the lifting unit.
- Install lifting accessory: even surface, clean and firm base. The storage area and installation location must be easily accessible.
- Attach two transport straps to the lifting unit. Secure the transport straps against slipping. Only use technically approved lifting slings.
- If it is no longer safe to work due to the weather conditions (e.g. ice formation, strong wind), stop work immediately.

6.4.1 Note on fixation material

The lifting unit can be installed on various constructions (concrete and steel construction, etc.). Select the fixation material which is suitable for the relevant construction. For correct installation, observe the following instructions for the fixation material:

- Avoid tearing or chipping of the construction surface, **observe the minimum edge distances.**
- Ensure tight and secure installation, **observe the prescribed borehole depth.**
- Drilling dust impairs holding strength, **always blow out or vacuum out the borehole.**
- Only use components (e.g. screws, anchors, mortar cartridges) which are in perfect condition.

6.4.2 Note on pipework

The pipework is exposed to different pressures during operation. Pressure peaks can occur (e.g. when closing the non-return valve) which may be several times higher than the pump pressure, depending on the operating conditions. These different pressures stress the piping and the pipe connections. In order to ensure safe and proper operation, the piping and pipe connections must be checked based on the following parameters and designed according to the requirements:

- Pipes are self-supporting.
No tensile or compressive forces must act on the lifting unit.
- Pressure resistance of pipework and pipe connections
- Tensile strength of the pipe connections (= longitudinal force fit connection)
- Connect the pipes free of stress and vibrations.

6.4.3 Work steps

The lifting unit is installed in the following steps:

- Preparatory tasks.
- Place the lifting unit.
- Connect the discharge pipe.
- Connect the inlet.
- Connect the ventilation.
- Connect the drain.

6.4.4 Preparatory tasks

- Unpack the lifting unit.
- Remove the transportation lock.
- Check the scope of delivery.
- Check that all components are in proper working condition.

CAUTION! Do not install defective components! Defective components can lead to system failures!

- Place accessories aside and keep them for later use.
- Prepare the installation location:
 - Horizontal and flat installation surface.
 - Ensure an extra free space of min. 60 cm (2 ft).
 - Fixation with dowels possible.
 - Clean, free of coarse solids
 - Dry
 - Frost-free
 - Well lit

6.4.5 Placing the lifting unit

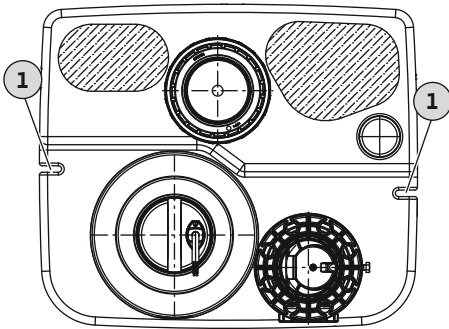

Fig. 2: Lifting unit top view

1 Fastening grooves for floor anchoring

Install the lifting unit to protect it against buoyancy and twisting. Anchor the lifting unit to the floor for this purpose.

- ✓ Preparatory tasks completed.
 - ✓ Installation location prepared according to the consulting documents.
 - ✓ Suitable fixation material provided for the existing building floor. **NOTICE! Observe the information on the fixation material!**
1. Place the lifting unit at the installation location and align it to the pipework.
CAUTION! Secure the switchgear to the lifting unit to prevent it from falling down! The switchgear may break if dropped!
NOTICE! Lifting unit must be upright!
 2. Mark the drilling holes of the fastening grooves.
 3. Place the lifting unit aside.
 4. Drill and clean the holes. Insert the dowels.
 5. Lay out and align the noise insulation mat.
 6. Place and align the lifting unit to the noise insulation mat.
 7. Insert the fastening screw and washer through the fastening groove. Screw the fastening screw into the dowel.
 8. Fasten the lifting unit to the floor.
 9. Fasten the switchgear to the wall to protect the switchgear from flooding (see switchgear instructions).
 10. Lay the connection cable according to regulations.
 - ▶ Lifting unit installed to protect it against buoyancy and twisting. Next step: Connect the discharge pipe.

6.4.6 Connecting the discharge pipe

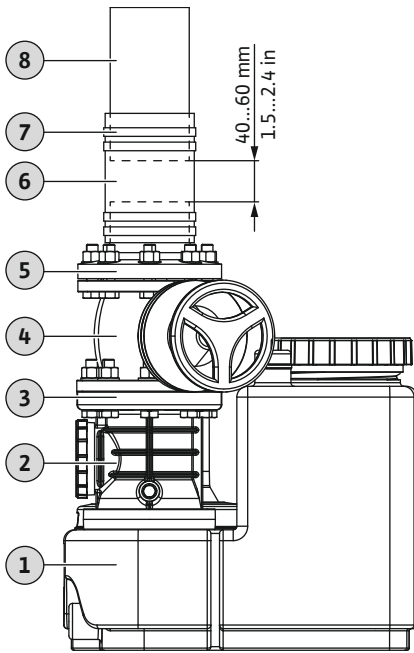

Fig. 3: Fitting discharge connection

1	Lifting unit
2	Non-return valve
3	Discharge port
4	Shut-off valve
5	Flange connector
6	Collar, flexible
7	Pipe clamp
8	Discharge pipe

Observe the following information when connecting the discharge pipe:

- Discharge pipe must be DN 80 or DN 100.
- Flow rate in the discharge pipe: 0.7 m/s (2.3 ft/s) to 2.3 m/s (7.5 ft/s).
- Do not reduce the pipe diameter.
- All connections must be completely tight.
- Install the discharge pipe as a “pipe loop” to avoid backflow from the main public sewer. At its highest point, the bottom edge of the pipe loop must be above the locally defined backflow level.
- Install the discharge pipe for frost protection.
- Install the shut-off valve.

- ✓ Lifting unit installed properly.
- ✓ Discharge pipe installed correctly according to consulting documents and perpendicular to the discharge port.

- ✓ Assembly materials prepared:

- 1x shut-off valve
- 1x collar
- 4x pipe clamps
- 2x sealings
- 8x screws, washers, nuts

1. Install the shut-off valve on the discharge port. **Tightening torque: 8 Nm (5.9 ft-lb)!**
2. Install flange connector on the shut-off valve. **Tightening torque: 8 Nm (5.9 ft-lb)!**
 - ⇒ To ensure that the discharge pipe is connected in an acoustically isolated manner, maintain a distance between the end of the discharge pipe and the end of the flange connector of 40 ... 60 mm (1.5 ... 2.4 in).
 - If the distance is too small, shorten the discharge pipe.
 - If the distance is too large, extend or replace the discharge pipe.
3. Place the pipe clamps to the flange connector.
4. Slide the collar over the discharge pipe.
5. Slide the collar over the flange connector.
6. Align the collar centrally between the flange connector and the discharge pipe.
7. Fasten the collar to the flange connector and discharge pipe with two pipe clamps each. **Tightening torque: 5 Nm (3.7 ft-lb)!**
 - Discharge pipe connected. Next step: Connect the inlet.

6.4.7 Connecting the inlet

The inlet can be located in the areas indicated on the rear wall, both side walls and the tank roof, as desired.

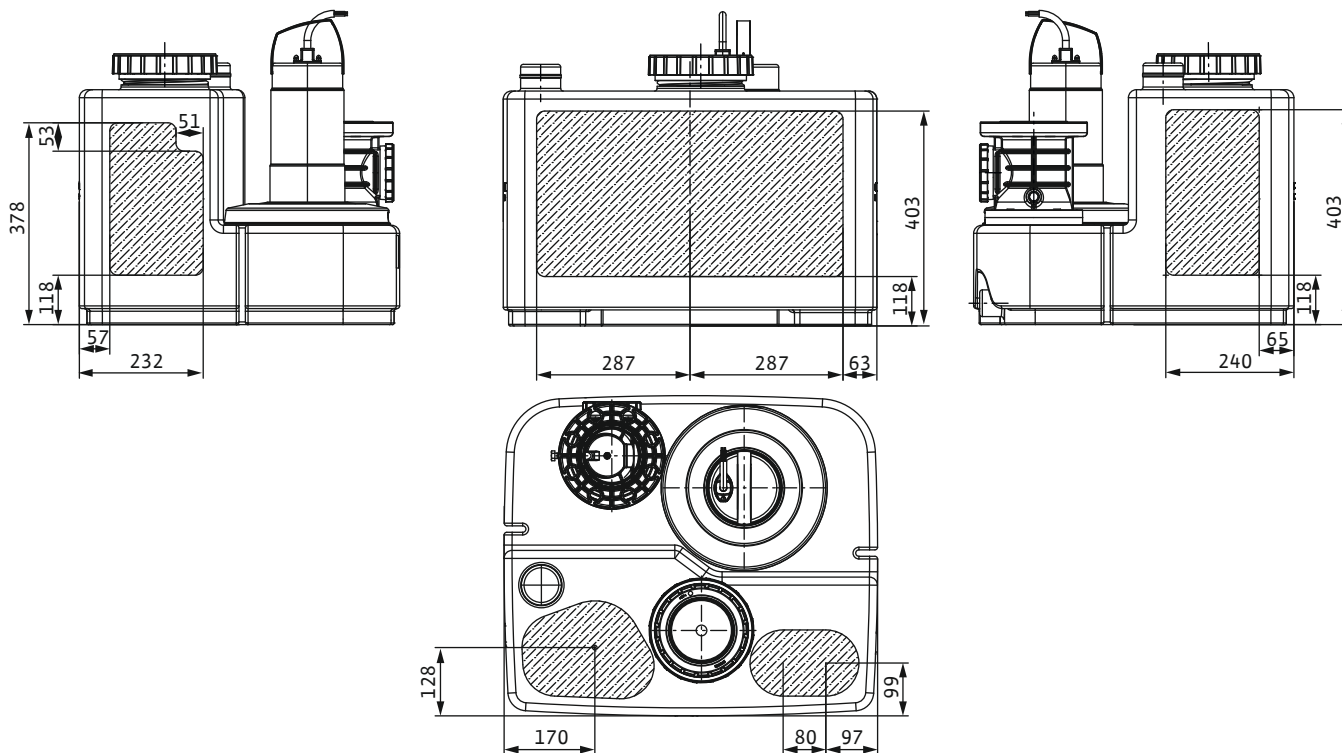

Fig. 4: Inlet areas

Note the following to connect the inlet:

- Connect the inlet only within the marked areas. If the inlet is located outside the marked areas, the following problems can occur:
 - The connection leaks.
 - Backflow into the inlet pipe.
 - Function of the lifting unit can be impaired.
- Avoid a surging inflow and air intake into the collection tank. Install the inlet properly. **CAUTION! Surging inflow or air intake into the collection tank can lead to malfunctions of the lifting unit!**
- To allow the inlet pipe to drain off by itself, install the inlet pipe with a slope gradient to the lifting unit.
- Minimum height from floor to the centre of the inlet: 180 mm (7 in).
- All connections must be tight.
- Install a shut-off valve in the inlet pipe.

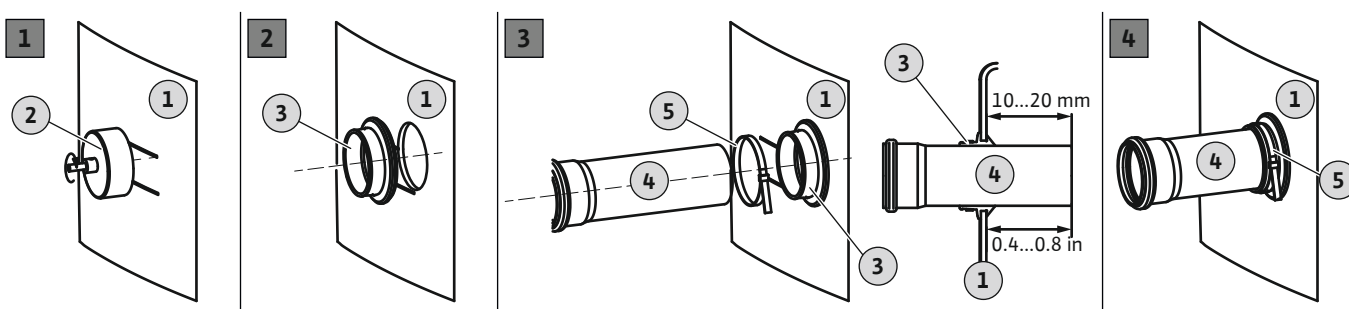

Fig. 5: Connecting the inlet

1	Tank wall
2	Hole saw for drill
3	Inlet seal
4	Inlet pipe
5	Pipe clamp

- ✓ Lifting unit installed properly.
- ✓ Inlet pipe installed to the collection tank according to the consulting documents.
- ✓ Installation material prepared:
 - 1x hole saw 124 mm (5 in) included in the scope of delivery
 - 1x drill

1x seal DN 100 (110 mm) included in the scope of delivery
1x pipe clamp

1. Mark the inlet on the collection tank.
2. Cut the hole with the hole saw into the tank wall.
During the drilling of the hole, observe the following:
 - Observe the dimensions of the inlet area. **CAUTION! The drilled hole must be completely within the marked inlet area!**
 - Max. speed of the drill: 200 rpm.
 - Check the hole diameter. **NOTICE! Drill the hole carefully. Impermeability of the connection depends on the drilled hole!**
 - The drilling chips must fall cleanly from the hole saw. If the drilling chips stick to the hole saw, the material heats up too quickly and melts. If the material melts, observe the following instructions:
 - ⇒ Stop drilling, let the material cool down, and clean the hole saw.
 - ⇒ Reduce the drilling speed.
 - ⇒ Vary feed rate during drilling.
3. Deburr and smooth the cut edge.
4. Insert the seal into the hole.
5. Push the pipe clamp onto the seal.
6. Coat the inner surface of the seal with lubricant.
7. Push the inlet pipe into the seal.
Push the inlet pipe 10 ... 20 mm (0.4 ... 0.8 in) into the collection tank.
 - ⇒ The value specification need to be observed, or else the function of the lifting unit can be impaired.
8. Connect the seal and pipe with the pipe clamp. **Tightening torque: 5 Nm (3.7 ft·lb)!**
 - ▶ Inlet connected. Next step: Connect the ventilation.

6.4.8 Connect the ventilation

The connection of a ventilation pipe is mandatory. Furthermore, ventilation is absolutely necessary to ensure proper functioning of the lifting unit. Observe the following points when connecting the ventilation pipe:

- Guide the ventilation pipe over the roof.
- All connections must be completely tight.

3	Collection tank ventilation connection
4	Discharge port

- ✓ Lifting unit installed properly.
 - ✓ Ventilation pipe laid properly.
1. Place the HT double socket onto an open ventilation connection.
 2. Insert the ventilation pipe into the HT double socket.
 - ▶ Ventilation pipe installed. If required, connect a diaphragm hand pump to the connection for emergency drainage.

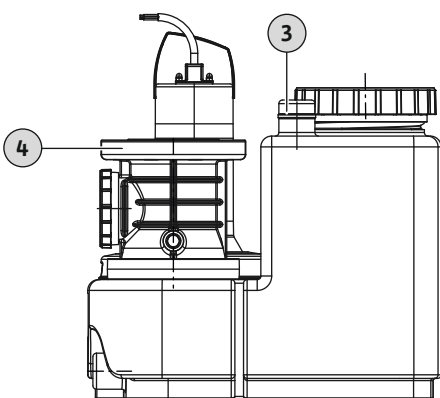

Fig. 6: Collection tank ventilation connection

6.4.9 Installation of a diaphragm hand pump



NOTICE

Do not connect the inlet to the drain connection!

The collection tank is pumped out via the drain connection for inspection work or in the event of an accident. Do not connect inlets to the drain connection! Otherwise, the collection tank cannot be drained in case of emergency!

The collection tank must be manually pumped out if maintenance work is performed or if the lifting unit malfunctions. It is recommended to install a diaphragm hand pump for this purpose.

CAUTION! If the lifting unit malfunctions, there is backflow into the inlet and the collection tank can burst! Shut off the inlet and drain the collection tank!

4	Discharge port
7	Drain connection

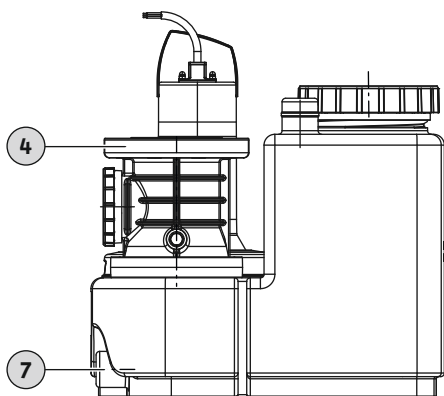

Fig. 7: Connection of diaphragm hand pump

Observe the following points when installing a diaphragm hand pump:

- Select an installation height for optimum operation.
- Connect the diaphragm hand pump to the drain connection (lowest point, almost complete drain possible).
- A hole saw 30 mm (1.3 in) is required to drill the drain connection.
- Connect the discharge pipe downstream of the shut-off valve on the discharge side. Alternatively, the connection can be made via a pipe loop directly to the sewer.
- All connections must be completely tight.
- Observe the installation and operating instructions of the diaphragm hand pump.

6.5 Electrical connection



DANGER

Danger of death due to electrical shock!

Improper conduct when carrying out electrical work can lead to danger of death due to electric shock!

- Perform electrical work by a qualified electrician.
- Observe local regulations.

6.5.1 Fuse on mains side

Circuit breaker

- Select the type and switching characteristics of the circuit breakers according to the rated current of the connected product.
- Observe local regulations.

Residual-current device (RCD)

- Install a residual-current device (RCD) according to the regulations of the local energy supply company.
- If persons can come into contact with the device and conductive fluids, install a residual-current device (RCD).

6.5.2 Mains connection

- Observe information on the rating plate.
- Earth the device according to local regulations.
- Install the socket so that it is protected from flooding.
- Socket type:

Single-phase current:

- DrainLift SANI-M...M/...: CEE 7/7 (Schuko)

Three-phase current:

- DrainLift SANI-M...T/...: CEE 16A, 3P+N+PE, 6 h, clockwise rotating field

6.5.3 Switchgear

The switchgear is pre-wired and factory-set. Lay all connection cables to the switchgear and mains connection according to local regulations. **CAUTION! Install the switchgear so that it is protected from flooding!**

The switchgear has the following basic functions:

- Level-dependent control
- Motor protection
- Direction of rotation monitoring (only for the three-phase current)
- High water alarm

For detailed information, refer to the installation and operating instructions for the switchgear:

- Electrical connection of the lifting unit to the switchgear
- Overview and description of functions
- Setting the switching points



Switching points

The switching points of the lifting unit can be adjusted to the inlet height of the lowest inlet. This results in a greater usable volume. The switching point data always refers to the floor.

NOTICE! If the inlet is lower than the “Pump ON” switching point, there is backflow in the inlet pipe!

Wilo-Control MS-L switchgear

The switching points are set via permanently defined parameter sets for the Wilo-Control MS-L switchgear. Set the required parameter set to DIP switch 3:

Switching points	Setting DIP switch 3	Factory setting/se- lectable
Pump ON: 180 mm (7 in) Pump OFF: 115 mm (4.5 in) High water alarm: 200 mm (8 in)		•
Pump ON: 250 mm (10 in) Pump OFF: 115 mm (4.5 in) High water alarm: 270 mm (10.5 in)		o
Pump ON: 315 mm (12.5 in) Pump OFF: 115 mm (4.5 in) High water alarm: 335 mm (13 in)		o

Key

• = factory setting, o = adjustable

NOTICE! For the position of DIP switch 3, refer to the installation and operating instructions of the switchgear!

Wilo-Control EC-L switchgear

The switching points are set via the menu for the Wilo-Control EC-L switchgear. Set the following values in the specified menus:

Switching points	Factory setting/selectable	Menu 5.09	Menu 1.12	Menu 1.13	Menu 5.51
Pump ON: 180 mm (7 in) Pump OFF: 115 mm (4.5 in) High water alarm: 200 mm (8 in)	•	1.00	0.46	0.19	0.53
Pump ON: 250 mm (10 in) Pump OFF: 115 mm (4.5 in) High water alarm: 270 mm (10.5 in)	o	1.00	0.69	0.19	0.75
Pump ON: 315 mm (12.5 in) Pump OFF: 115 mm (4.5 in) High water alarm: 335 mm (13 in)	o	1.00	0.90	0.19	0.96

Key

- = factory setting, o = adjustable, switching point unit: Metres (m)

NOTICE! Refer to the switchgear installation and operating instructions for functional details and a description of the menu!

6.5.4 Operation with frequency converter

Operation with the frequency converter is not permitted.

7 Commissioning

**WARNING****Foot injuries due to a lack of protective equipment!**

Danger of (serious) injuries during work.

- Wear safety shoes.

**NOTICE****Automatic switching on after power blackout**

Depending on the process, the product is switched on and off using separate controls. The product can be automatically switched on after power blackout.

7.1 Staff qualifications

- Operation/control: the staff is informed on how the system operates

7.2 Operator responsibilities

- Provide installation and operating instructions with the lifting unit or at a place specially reserved for it.
- Make the installation and operating instructions available in the language of the staff.
- Make sure that the installation and operating instructions are read and understood by all staff.
- All safety devices and emergency stop circuits must be active and checked to ensure that they function properly.
- The lifting unit is suitable for use under the specified operating conditions.

7.3 Operation

CAUTION**Malfunction due to incorrect operation of the switchgear!**

When the plug is inserted, the switchgear starts in the last operating mode that was set.

- In order to be familiar with the operation of the switchgear, read the installation and operating instructions for the switchgear before inserting the plug.

The lifting unit is operated by the switchgear. The switchgear is pre-set for the lifting unit. Read the installation and operating instructions for the switchgear to ensure it is correctly operated:

- Settings
- LED displays/LC display
- Alarm signals

7.4 Test run

Perform a test run before operating the lifting unit in automatic mode. A test run checks the proper functioning and impermeability of the unit. If necessary, adjust the pump's follow-up time to guarantee optimum operation of the unit.

- ✓ Lifting unit installed properly.
 - ✓ Connections checked for correctness.
1. Activate the lifting unit: Insert plug into socket.
 2. Select automatic mode on the switchgear.
 3. Open the shut-off valve in the discharge pipe.

NOTICE! The shut-off valve in the inlet remains closed!

4. Unscrew the inspection cover on the collection tank.
5. Slowly fill the collection tank with water via the inspection opening with a hose.
NOTICE! Malfunction! Do not hold water jet directly above the float switch!
6. The lifting unit is switched on and off using the level control.
 - ⇒ Perform at least two complete pumping operations of all pumps for a test run.
 - ⇒ Fill the discharge pipe completely with water to check the duty point. Repeat the test run until the discharge pipe is completely full.
7. Screw the inspection cover back on. **NOTICE! Tightly seal the inspection opening on the collection tank!**
8. Check all connections for impermeability.
 - ⇒ If all connections are leak-proof, the lifting unit can run in automatic mode.
 - ▶ Test run completed.
 - ▶ Lifting unit **is commissioned**: Keep shut-off valve open in the **discharge pipe**.
 - ▶ Lifting unit **is in standby mode**: Close the shut-off valve in the **discharge pipe**.

7.5 Follow-up time

The follow-up time is pre-set at the factory to 3 seconds. The follow-up time can be adjusted as required:

- Increasing the usable volume per pumping process.
- Extensive suction of settling sediments at the bottom of the tank through integrated deep suction.
- Slurping operation to avoid pressure surges.

To set the follow-up time, read the installation and operating instructions for the switchgear.

CAUTION! Pay attention to the operating mode if the follow-up time is changed! The operating mode indicates the duty period and the standby time!

7.6 Setting the venting screw

The non-return valve is equipped with a venting screw. The non-return valve can be opened via the venting screw for inspection. As a result, the remaining fluid can flow back into the collection tank from the discharge pipe. Restore the factory setting of the venting screw to ensure proper operation of the non-return valve.

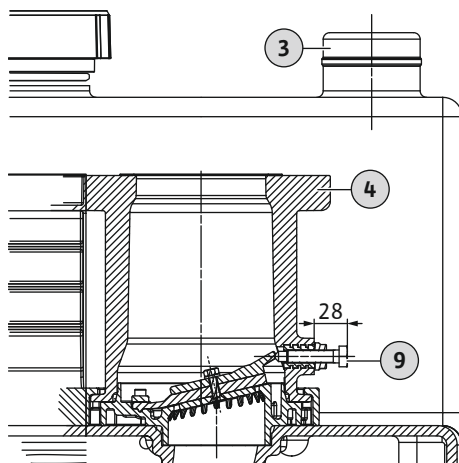

Fig. 8: Position of the venting screw

3	Collection tank ventilation connection
4	Discharge port
9	Venting screw

✓ Lifting unit in standby mode.

1. Check factory setting of the venting screw: 28 mm (1.1 in)
2. Unscrew the venting screw if it is screwed in too far (> 28 mm/1.1 in).

CAUTION! If the venting screw is screwed in too far, this causes damage to the non-return valve. This also leads to loud noises!

8 Operation

The lifting unit operates in automatic mode by default and is switched on and off via the integrated level control device.



WARNING

Risk of burns from hot surfaces!

The motor can get hot during operation and present a risk of burning skin if touched

- Allow the motor to cool down to ambient temperature after switching it off.

- ✓ Commissioning has been carried out.
- ✓ Test run has been completed successfully.
- ✓ The handling and functioning of the lifting unit are known.
- ✓ Discharge pipe is completely filled with water.

1. Activate the lifting unit: Insert plug into socket.
2. Select automatic mode on the switchgear.
3. Open the shut-off valve in the inlet and discharge pipe.
 - ▶ The lifting unit operates in automatic mode and is controlled depending on level.

8.1 Application limits

Improper use and overload lead to damage to the lifting unit. The following application limits must be strictly observed:

- Max. inlet height of the lowest inlet: 5 m (16 ft)
- Max. pressure in the discharge pipe: 6 bar (87 psi)
- Fluid temperature: 3 ... 40 °C (37 ... 104 °F), max. 65 °C (149 °F) for 5 min
- Ambient temperature: 3 ... 40 °C (37 ... 104 °F)

8.2 During operation

CAUTION

Material damage due to pressure surges

Pressure surges can occur when switching off the pump. These pressure surges can damage the discharge pipe and the lifting unit.

- Increase the follow-up time to prevent the pressure surges.
- An extended follow-up time results in slurping operation and smoother closing of non-return valve.



NOTICE

System problems when delivery head is too low

If the geodesic delivery head is below 2 m (6.5 ft), a leakage into the collection tank can occur. The non-return valve does not close tightly due to a lack of required counter pressure. This can result in repeated switching on and off (cycling) of the lifting unit.

- Open shut-off valves in the inlet and discharge pipe.
- The maximum inflow must be lower than the maximum output of the system.
- Do not open inspection openings on the collection tank and non-return valve.
- Ensure the collection tank is well ventilated.

8.3 Emergency operation

8.3.1 Level control failure

If the level control fails, drain the collection tank in manual mode. For all relevant information on manual mode, refer to the installation and operating instructions for the switchgear.

CAUTION! Continuous duty is not permitted! Observe the operating mode! The operating mode indicates the duty period and the standby time!

8.3.2 Lifting unit failure

If the lifting unit completely fails, pump out the sewage using a diaphragm hand pump.

1. Close the shut-off valve in the inlet.
2. Close the shut-off valve in the discharge pipe.
3. Pump sewage into the discharge pipe using the diaphragm hand pump.

8.3.3 Flooding of the lifting unit (accident)



DANGER

Danger due to fluids hazardous to health!

In the event of an accident, contact with the collected sewage can occur.

Observe the following points:

- Wear protective equipment:
 - Single-use body suit
 - Sealed safety goggles
 - Respiratory mask
- Accessories used (e.g. diaphragm hand pump, hoses) must be thoroughly cleaned and disinfected after the work is completed.
- Disinfect the lifting unit and operating space.
- Flush rinsing water into the sewer system.
- Dispose of protective clothing and cleaning material according to local regulations.
- Observe the factory regulations! The operator must ensure that the staff have received and read the factory regulations!



NOTICE

Operation of the lifting unit in the event of high water

The switchgear is not protected from flooding. To ensure operation of the lifting unit even in the event of high water, install the electrical connections and the switchgear at a suitably high level!

9 Shutdown/dismantling

9.1 Staff qualifications

- Operation/control: the staff is informed on how the system operates
- Electrical work to be performed by a qualified electrician.
A qualified electrician is a person with appropriate technical training, knowledge, and experience who can identify and prevent electrical hazards.

9.2 Operator responsibilities

- Installation and dismantling to be performed by a trained expert for sanitary installations, including fastening of buoyancy safeguard and connection of plastic pipes.
- Observe locally applicable accident prevention and safety regulations of trade associations.
- Provide the necessary protective equipment and make sure that the staff wears it.
- Ensure closed spaces are well ventilated.
- Take immediate countermeasures if there is a build-up of toxic or suffocating gases.
- When working in chambers and closed spaces, a second person must be present for safety reasons.
- When using a lifting accessory, all regulations for working with and under suspended loads must be observed.

9.3 Shutdown

1. Close the shut-off valve in the inlet pipe.
2. Switch the switchgear to standby mode.
3. Drain the collection tank.
Activate the lifting unit in manual mode and drain the collection tank.
4. Close the shut-off valve in the discharge pipe.
5. Switch off the lifting unit.
Pull the plug out of the socket. **CAUTION! Secure the lifting unit against unauthorised reactivation!**
 - ▶ The lifting unit is now decommissioned.

If the lifting unit is decommissioned for an extended period, perform a functional check at regular intervals (quarterly). **CAUTION! Perform the functional check as described under "Test run".**



DANGER

Danger due to fluids hazardous to health!

In the event of an accident, contact with the collected sewage can occur. Observe the following points:

- Wear protective equipment:
 - Single-use body suit
 - Sealed safety goggles
 - Respiratory mask
- Accessories used (e.g. diaphragm hand pump, hoses) must be thoroughly cleaned and disinfected after the work is completed.
- Disinfect the lifting unit and operating space.
- Flush rinsing water into the sewer system.
- Dispose of protective clothing and cleaning material according to local regulations.
- Observe the factory regulations! The operator must ensure that the staff have received and read the factory regulations!



DANGER

Danger of death due to electrical shock!

Improper conduct when carrying out electrical work can lead to danger of death due to electric shock!

- Perform electrical work by a qualified electrician.
- Observe local regulations.



DANGER

Risk of injury due to working alone!

Performing work in chambers and narrow rooms as well as in areas with risk of falling can be dangerous. Do not perform this work alone!

- Only perform the work with another person!



WARNING

Risk of burns from hot surfaces!

The motor can get hot during operation and present a risk of burning skin if touched

- Allow the motor to cool down to ambient temperature after switching it off.

- ✓ Lifting unit decommissioned.
 - ✓ Protective equipment used.
 - ✓ All shut-off valves closed.
1. To drain the discharge pipe into the tank, open the non-return valve using the ventilation device.
 2. Pump out the remaining fluid using the diaphragm hand pump.
 3. Remove connection to inlet. Pull the inlet pipe out of the inlet seal.
 4. Remove connection from the discharge pipe. Remove the collar.
 5. Loosen the connection at the ventilation connection of the collection tank. Pull ventilation pipe out of HT bushing.
 6. Remove suction line of the diaphragm hand pump from drain connection.
- DANGER! Health risk due to contact with sewage! The remaining sewage flows out of the collection tank via the drain connection. Collect sewage in suitable tanks and feed it into the sewer system.**

7. Loosen the floor anchoring.
8. Pull the lifting unit carefully out of the pipework.
 - ▶ Lifting unit is dismantled. Clean and disinfect the lifting unit and the operating space.

9.5 Clean and disinfect



DANGER

Danger due to fluids hazardous to health!

Disinfect the lifting unit before any further work! Wear the following protective equipment during cleaning tasks:



- Sealed safety goggles



- Respiratory mask

- Protective gloves

- The equipment listed here is the minimum requirement. Observe the factory regulations! The operator must ensure that the staff have received and read the factory regulations!

- ✓ Lifting unit is dismantled.
- ✓ Switchgear packed watertight.
- ✓ Rinse water flushed into the sewer according to local regulations.
- ✓ A disinfectant according to factory regulations is available.

NOTICE! Strictly observe the manufacturer's specifications for use!

1. Spray the lifting unit with clean water from top to bottom.
2. Open and rinse the inspection opening on the collection tank and the non-return valve.
3. Spray all connection ports from the inside.
4. Rinse all dirt residues on the floor into the sewer.
5. Let the lifting unit dry out.
6. Close the inspection opening on the collection tank and non-return valve again.

10 Maintenance and repair

Maintenance and repair work can **only** be carried out by qualified staff (e.g. customer service). The maintenance intervals in accordance with EN 12056-4:

- ¼ year for commercial operations
- ½ year for multi-residential buildings
- 1 year for detached houses

Record all maintenance and repair work in a log. The log must be signed by the qualified staff and the operator.

Perform a test run after the maintenance work.

10.1 General overhaul

During the general overhaul, the motor bearings, shaft sealings, O-rings and connection cables are checked for wear and damage. Damaged components are replaced with original parts. This ensures proper operation.

The general overhaul is performed by the manufacturer or an authorised service centre.

11 Spare parts

Spare parts are ordered via customer service. To avoid return queries and incorrect orders, the serial or article number must always be supplied. **Subject to change without prior notice!**

12 Disposal

12.1 Protective clothing

Dispose of worn protective clothing according to the local regulations.

12.2 Oils and lubricants

- Collect the operating fluid in suitable tanks.
- Immediately clean up leaked liquid.
- Dispose of the operating fluid according to the local regulations.

12.3 Information on the collection of used electrical and electronic products

Proper disposal and appropriate recycling of this product avoid environmental damage and dangers to your personal health.



NOTICE

Do not dispose of in domestic waste!

This symbol means do not dispose of the electrical and electronic product in domestic waste. The symbol is included on the product, packaging, or accompanying documentation.

Note the following points for proper handling, recycling, and disposal of the product:

- Only hand over the product at designated, certified collection points.
- Observe the locally applicable regulations.

Consult your local municipality, the nearest waste disposal site, or your retailer for information on proper disposal. See www.wilo-recycling.com for more information about recycling.







wilo



Local contact at
www.wilo.com/contact

Pioneering for You

WILO SE
Wilopark 1
44263 Dortmund
Germany
T +49 (0)231 4102-0
T +49 (0)231 4102-7363
wilo@wilo.com
www.wilo.com