

Data Sheet | Item Number: 771-8292/115-605

pre-assembled connecting cable; B2ca; Socket/open-ended; 2-pole; Cod. B; Control cable 2 x 1.0 mm²; 6 m; 1,00 mm²

<https://www.wago.com/771-8292/115-605>

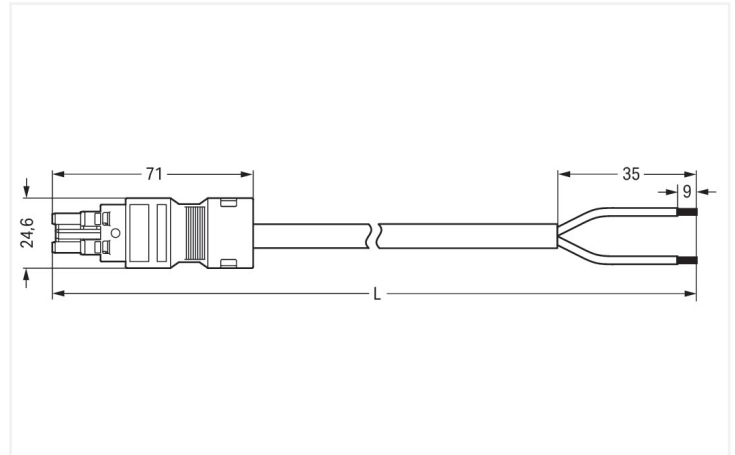
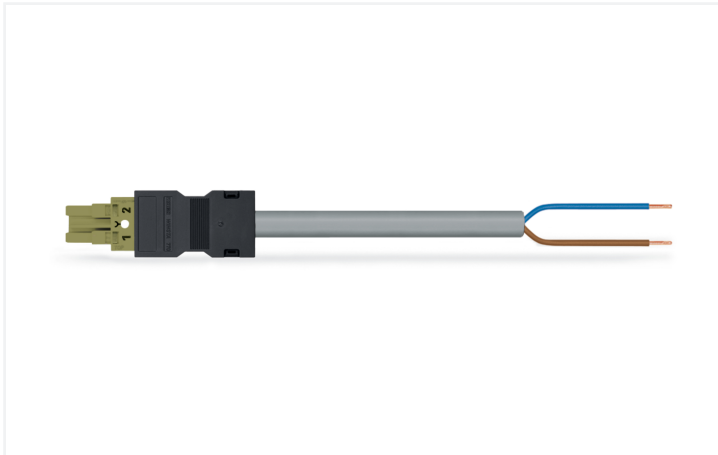

Dimensions in mm

Cable assembly WINSTA® MIDI with protection against mismatching

The WINSTA® MIDI cable assembly rated current 10 A provides the foundation for assembly of solid and fine-stranded conductors. Our pluggable installation connectors with spring pressure connection technology work completely without screw connections. They allow fast, efficient, error-free installation in a large number of applications. The mechanical coding and color coding of the pluggable installation connector ensure error-free installation of the individual components – including protection against mismatching. The pluggable installation connector is protected against ingress by solid objects in accordance with protection type IP20 (When mated: IP2xC (These compact connectors are not designed for use in open, easily accessible areas!)). Solutions like the WINSTA® MIDI pluggable installation connectors with B coding are appropriate for applications involving process control, for example, for lighting or in data networks. WINSTA® MIDI with Push-in CAGE CLAMP® spring pressure connection technology is found in a broad range of individual products you can use for quick, easy and maximally flexible electrical installation. If you need to meet stricter safety standards, you should use cables with fire class B2. These are suitable for use in buildings with very high demands on safety. In the production of this cable assembly, halogens were deliberately omitted. That is an important contribution to environmental protection.

Fast, secure pluggable connections – cable assemblies from WAGO

A socket and a free end are provided. WINSTA® is the pluggable connection system that is ideally tailored to the strict requirements of electrical installation. It ensures fast, secure and, above all, error-free installation of components and cables. Enjoy the benefits of the pluggable version of our maintenance-free spring pressure connection technology too! Plan your installation with with fire class B2 from WAGO.

- pluggable installation connectors with protection against mismatching
- simple circuits
- for automation controllers
- ready for immediate use
- quick replacement of defective units during ongoing operation

Notes

Note	Cables with a different fire class can be found in the eShop.
Variants:	Other pole markings Other versions (or variants) can be requested from WAGO Sales or configured at https://configurator.wago.com/ .

Electrical data

Ratings per	IEC/EN 60664-1		
Overvoltage category	III	III	II
Pollution degree	3	2	2
Nominal voltage	250 V	-	-
Rated impulse withstand voltage	4 kV	-	-
Rated current	10 A	-	-

General information

Note on contact resistance	approx. 1 mΩ of contact resistance approx. 0.25 mΩ contact transition plug/ socket
----------------------------	--

Connection Data

Total number of potentials	2
Conductor preparation	ultrasonically tip-bonded

Connection 1

Strip length	9 mm / 0.35 inches
Pole number	2
Wire cross-section	1 mm ²
Strip length (outer insulation)	35 mm
Connection type	Socket - free end

Physical data

Pin spacing	10 mm / 0.394 inches
Width	24.6 mm / 0.969 inches
Height	15.9 mm / 0.626 inches
Total length	6 m

Mechanical data

Use	Control technology
Coding	B
Variable coding	No
Marking	1 2
Potential marking	1 2
Mating force of a plug-in connection	approx. 20 ... 70 N (depending on pole number)
Retention force of a plug-in connection	when locked: > 80N
Unmating force of a plug-in connection	when unlocked: approx. 20 ... 70 N (depending on pole number)
Number of mating cycles	200, without resistive load
Connection type	Socket - free end
Type of pre-assembled cable	Connecting cable
Cable type	H05Z1Z1-F 2x1
Protection type	IP20; When mated: IP2xC (These compact connectors are not designed for use in open, easily accessible areas!)

Plug-in connection

Mismating protection	Yes
Note on mismating protection	All <i>WINSTA</i> ® components are 100% protected against mismating when: a.) plugging different numbers of poles b.) plugging while rotated 180 c.) plugging while laterally staggered d.) plugging one pole
Locking lever	Can be retrofitted
Locking of plug-in connection	Locking lever
Note on locking system	All connectors for mounted installations (snap-in versions for lighting fixtures or devices, all types of PCB and distribution connectors) are factory-equipped with locking levers to ensure plugs and sockets are securely locked. Additional locking levers are only required for flying leads (plug/socket).

Material data

Note (material data)	Information on material specifications can be found here
Insulation material (main housing)	Polyamide (PA66)
Flammability class per UL94	V0
Fire class per EN 50575	B2 _{ca}
Contact material	Copper or copper alloy; surface-treated
Contact Plating	Tin
Fire load	0.308 MJ
Connector color	light green
Strain relief color	black
Sheathed cable color	gray
Printing color of sheathed cable	black
Halogen-free	Yes
Silicon-free	Yes
Sheath material	Halogen-free
Rubber cable	No
Weight	365.8 g
Copper weight of the raw cable	0.0192 kg/m

Environmental requirements

Processing temperature	-5 ... +40 °C
Continuous operating temperature	-35 ... +85 °C
Note on continuous operating temperature	Cable for temperatures ≤ 70 °C (including halogen-free) Insulating parts for temperatures ≤ 105 °C

Commercial data

PU (SPU)	1 pcs
Packaging type	unpacked
Country of origin	DE
GTIN	4055143798365
Customs tariff number	85444290900

Product Classification

UNSPSC	26121629
eCl@ss 10.0	27-44-06-04
eCl@ss 9.0	27-44-06-04
ETIM 9.0	EC002587
ETIM 10.0	EC002587
ECCN	NO US CLASSIFICATION

Environmental Product Compliance

RoHS Compliance Status	Compliant, No Exemption
------------------------	-------------------------

Downloads

Environmental Product Compliance

Compliance Search

Environmental Product
Compliance
771-8292/115-605



CAD/CAE-Data

CAE data

EPLAN Data Portal
771-8292/115-605



1 Compatible Products

1.1 Required Accessories

1.1.1 Locking system

1.1.1.1 Locking system



[Item No.: 770-101](#)

Locking lever; for flying leads; for manual operation; black



[Item No.: 770-121](#)

Locking lever; for flying leads; for manual operation; white



[Item No.: 770-111](#)

Locking lever; for flying leads; for tool operation; black



[Item No.: 770-131](#)

Locking lever; for flying leads; for tool operation; white

1.2 Optional Accessories

1.2.1 Cover

1.2.1.1 Cover



[Item No.: 770-201](#)

Lockout cap; 12-pole, separable; for sockets; Plastic; black



[Item No.: 770-221](#)

Lockout cap; 12-pole, separable; for sockets; Plastic; white



[Item No.: 897-2003](#)

Protective cap; Type2; for sockets and plugs; PVC; red

1.2.2 Installation

1.2.2.1 Mounting accessories



[Item No.: 770-310](#)

Mounting carrier; 2- to 5-pole; for flying leads; black

1.2.3 Marking

1.2.3.1 Marking strip



Item No.: 210-334

Marking strips; as a DIN A4 sheet; Strip width 5 mm; Strip length 182 mm; plain; Self-adhesive; white