

Data Sheet | Item Number: 771-8382/066-101

pre-assembled interconnecting cable; Cca; Socket/plug; 2-pole; Cod. I; H05Z1Z1-F
2 x 1,50 mm²; 1 m; 1,50 mm²

<https://www.wago.com/771-8382/066-101>

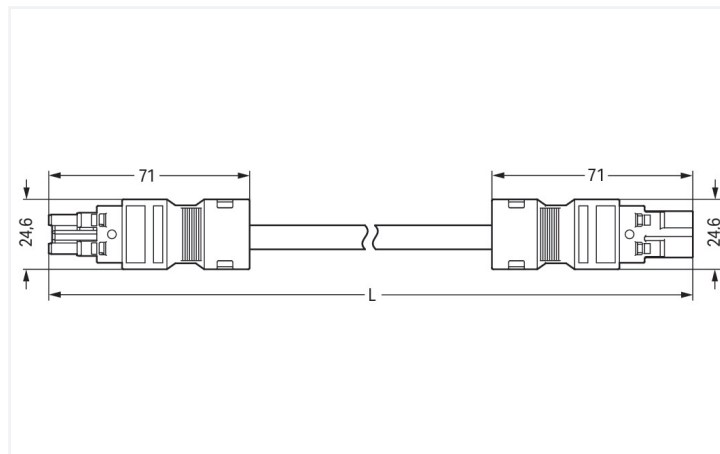

Dimensions in mm

Cable assembly WINSTA® MIDI 2-pole

The WINSTA® MIDI cable assembly with protection against mismatching supports rapid, correct installation. WAGO pluggable installation connectors can be used when criteria repeat or are distributed on a specified pattern, for example for installing grid lighting or flush-mount lighting. For greater protection in electrical installations, the pluggable installation connector is provided with mechanical protection against mismatching. The pluggable installation connector is protected in accordance with protection type IP20 (When mated: IP2xC (These compact connectors are not designed for use in open, easily accessible areas!)). That results in the fact that users' fingers will never come into contact with energised elements. WINSTA® MIDI pluggable installation connectors with I coding in blue are especially suitable for lighting management, for instance for the dimming of DALI lights. The WINSTA® MIDI product line achieves total flexibility for the installation of applications. With its Push-in CAGE CLAMP® spring pressure connection technology, it ensures time-saving, error-free installation and offers flexibility and customization for meeting various installation requirements. Compliance with fire protection regulations is an important issue for building installation. Especially in sensitive areas, the fire class must meet legal requirements. This product complies with the requirements of fire class C. The cable assembly is free of halogen. This eliminates the addition of environmental pollutants during production. It also increases the fire class, since halogen-free materials are flame-resistant.

Pluggable connections instead of screw connections – cable assemblies from WAGO

The cable assembly is provided with a socket and a plug. WINSTA® is the pluggable connection system that is ideally tailored to the strict requirements of electrical installation. It offers fast, secure and, above all, error-free installation of components and cables. Now you can also cut installation costs without compromising safety and quality: with protection type IP20 reduces the need for servicing and prevents unnecessary downtime.

- pluggable installation connectors with protection against mismatching
- for automation controllers
- for lighting management
- exact dimensions
- convenient installation and commissioning

Notes

Note	Cables with a different fire class can be found in the eShop.
------	---

Electrical data

Ratings per	IEC/EN 60664-1			General information	
Overtoltage category	III	III	II	Note on contact resistance	approx. 1 mΩ of contact resistance approx. 0.25 mΩ contact transition plug/ socket
Pollution degree	3	2	2		
Nominal voltage	250 V	-	-		
Rated impulse withstand voltage	4 kV	-	-		
Rated current	16 A	-	-		

Connection Data

Total number of potentials	2	Connection 1	
		Pole number	2
		Wire cross-section	1.5 mm ²
		Connection type	Socket - Plug

Physical data

Pin spacing	10 mm / 0.394 inches
Width	24.6 mm / 0.969 inches
Height	15.9 mm / 0.626 inches
Total length	1 m

Mechanical data

Use	DALI, Lighting Management
Coding	I
Variable coding	No
Marking	DA+ DA-
Potential marking	DA+ DA-
Mating force of a plug-in connection	approx. 20 ... 70 N (depending on pole number)
Retention force of a plug-in connection	when locked: > 80N
Unmating force of a plug-in connection	when unlocked: approx. 20 ... 70 N (depending on pole number)
Number of mating cycles	200, without resistive load
Connection type	Socket - Plug
Type of pre-assembled cable	Interconnecting cable
Cable type	H05Z1Z1-F 2x1.5
Protection type	IP20; When mated: IP2xC (These compact connectors are not designed for use in open, easily accessible areas!)

Plug-in connection

Mismating protection	Yes
Note on mismating protection	All <i>WINSTA</i> ® components are 100% protected against mismating when: a.) plugging different numbers of poles b.) plugging while rotated 180 c.) plugging while laterally staggered d.) plugging one pole
Locking lever	Can be retrofitted
Locking of plug-in connection	Locking lever
Note on locking system	All connectors for mounted installations (snap-in versions for lighting fixtures or devices, all types of PCB and distribution connectors) are factory-equipped with locking levers to ensure plugs and sockets are securely locked. Additional locking levers are only required for flying leads (plug/socket).

Material data

Note (material data)	Information on material specifications can be found here
Insulation material (main housing)	Polyamide (PA66)
Flammability class per UL94	V0
Fire class per EN 50575	C _{ca}
Contact material	Copper or copper alloy; surface-treated
Contact Plating	Tin
Fire load	1.408 MJ
Connector color	blue
Strain relief color	black
Sheathed cable color	black
Printing color of sheathed cable	white
Halogen-free	Yes
Silicon-free	Yes
Sheath material	Halogen-free
Rubber cable	No
Weight	102.7 g
Copper weight of the raw cable	0.029 kg/m

Environmental requirements

Processing temperature	-5 ... +40 °C
Continuous operating temperature	-35 ... +85 °C
Note on continuous operating temperature	Cable for temperatures ≤ 70 °C (including halogen-free) Insulating parts for temperatures ≤ 105 °C

Commercial data

PU (SPU)	1 pcs
Packaging type	unpacked
Country of origin	DE
GTIN	4055143841931
Customs tariff number	85444290900

Product Classification

UNSPSC	26121629
ETIM 9.0	EC002587
ETIM 10.0	EC002587
ECCN	NO US CLASSIFICATION

Environmental Product Compliance

RoHS Compliance Status	Compliant, No Exemption
------------------------	-------------------------

Downloads

Environmental Product Compliance

Compliance Search

Environmental Product
Compliance
771-8382/066-101



1 Compatible Products

1.1 Required Accessories

1.1.1 Locking system

1.1.1.1 Locking system

[Item No.: 770-101](#)

Locking lever; for flying leads; for manual operation; black

[Item No.: 770-121](#)

Locking lever; for flying leads; for manual operation; white

[Item No.: 770-111](#)

Locking lever; for flying leads; for tool operation; black

[Item No.: 770-131](#)

Locking lever; for flying leads; for tool operation; white

1.2 Optional Accessories

1.2.1 Cover

1.2.1.1 Cover

[Item No.: 770-201](#)

Lockout cap; 12-pole, separable; for sockets; Plastic; black

[Item No.: 770-221](#)

Lockout cap; 12-pole, separable; for sockets; Plastic; white

[Item No.: 770-360](#)

Lockout cap; for plugs; 5-pole; separable; yellow

[Item No.: 897-2003](#)

Protective cap; Type2; for sockets and plugs; PVC; red

1.2.2 Installation

1.2.2.1 Mounting accessories

[Item No.: 770-310](#)

Mounting carrier; 2- to 5-pole; for flying leads; black

1.2.3 Marking

1.2.3.1 Marking strip

[Item No.: 210-334](#)

Marking strips; as a DIN A4 sheet; Strip width 5 mm; Strip length 182 mm; plain; Self-adhesive; white

Subject to changes. Please also observe the further product documentation!

Current addresses can be found at: www.wago.com