

## Data Sheet | Item Number: 771-8382/066-501

pre-assembled interconnecting cable; Cca; Socket/plug; 2-pole; Cod. I; H05Z1Z1-F  
2 x 1,50 mm<sup>2</sup>; 5 m; 1,50 mm<sup>2</sup>

<https://www.wago.com/771-8382/066-501>

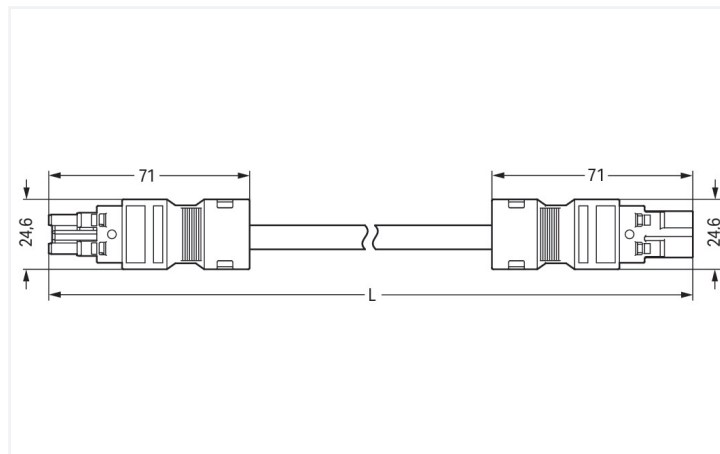

Dimensions in mm

### Cable assembly WINSTA® MIDI with protection against mismatching

The WINSTA® MIDI cable assembly with protection against mismatching is the pluggable solution for your application in control cabinets, for lighting connections or on PCBs. Whether on PCBs, in control cabinets or for connecting lights – pluggable installation connectors from WAGO allow you to establish connections according to many different requirements in seconds. For greater security in electrical installations, the pluggable installation connector is provided with mechanical protection against mismatching. The pluggable installation connector is protected in accordance with protection type IP20 (When mated: IP2xC (These compact connectors are not designed for use in open, easily accessible areas!)). That results in the fact that users' fingers will never come into contact with live contact elements. Regulated lighting, as used with the DALI standard, for instance, is the main use of WINSTA® MIDI pluggable installation connectors with I coding. The WINSTA® MIDI product line offers total flexibility for the electrical installation. Through its Push-in CAGE CLAMP® spring pressure connection technology, it ensures time-saving, error-free installation and offers flexibility and customization for meeting all installation requirements. If you need to satisfy stricter safety standards, you should use cables with fire class C. These are suitable for use in buildings with particularly high demands on safety. In the manufacturing of this cable assembly, we eliminated the use of halogen. This is an important contribution to environmental protection.

### Fast, secure pluggable connections – cable assemblies from WAGO

The cable is pre-assembled with a socket and a plug. WINSTA® is the pluggable connection system that is ideally tailored to the strict requirements of electrical installation. It ensures fast, secure and, above all, error-free installation of components and cables. Choose durability and quality – with strain relief hosting from WAGO makes the installation of electrical components significantly easier.

- effective protection against mismatching
- simple circuits
- for lighting management
- flexible installation to save space
- rapid, structured electrical installation

## Notes

Note Cables with a different fire class can be found in the eShop.

## Electrical data

Ratings per	IEC/EN 60664-1			General information	
Overtoltage category	III	III	II	Note on contact resistance	approx. 1 mΩ of contact resistance approx. 0.25 mΩ contact transition plug/ socket
Pollution degree	3	2	2		
Nominal voltage	250 V	-	-		
Rated impulse withstand voltage	4 kV	-	-		
Rated current	16 A	-	-		

## Connection Data

Total number of potentials	2	<b>Connection 1</b>	
		Pole number	2
		Wire cross-section	1.5 mm <sup>2</sup>
		Connection type	Socket - Plug

## Physical data

Pin spacing	10 mm / 0.394 inches
Width	24.6 mm / 0.969 inches
Height	15.9 mm / 0.626 inches
Total length	5 m

## Mechanical data

Use	DALI, Lighting Management
Coding	I
Variable coding	No
Marking	DA+ DA-
Potential marking	DA+ DA-
Mating force of a plug-in connection	approx. 20 ... 70 N (depending on pole number)
Retention force of a plug-in connection	when locked: > 80N
Unmating force of a plug-in connection	when unlocked: approx. 20 ... 70 N (depending on pole number)
Number of mating cycles	200, without resistive load
Connection type	Socket - Plug
Type of pre-assembled cable	Interconnecting cable
Cable type	H05Z1Z1-F 2x1.5
Protection type	IP20; When mated: IP2xC (These compact connectors are not designed for use in open, easily accessible areas!)

## Plug-in connection

Mismating protection	Yes
Note on mismating protection	All <i>WINSTA</i> ® components are 100% protected against mismating when: a.) plugging different numbers of poles b.) plugging while rotated 180 c.) plugging while laterally staggered d.) plugging one pole
Locking lever	Can be retrofitted
Locking of plug-in connection	Locking lever
Note on locking system	All connectors for mounted installations (snap-in versions for lighting fixtures or devices, all types of PCB and distribution connectors) are factory-equipped with locking levers to ensure plugs and sockets are securely locked. Additional locking levers are only required for flying leads (plug/socket).

### Material data

Note (material data)	<a href="#">Information on material specifications can be found here</a>
Insulation material (main housing)	Polyamide (PA66)
Flammability class per UL94	V0
Fire class per EN 50575	C <sub>ca</sub>
Contact material	Copper or copper alloy; surface-treated
Contact Plating	Tin
Fire load	4.864 MJ
Connector color	blue
Strain relief color	black
Sheathed cable color	black
Printing color of sheathed cable	white
Halogen-free	Yes
Silicon-free	Yes
Sheath material	Halogen-free
Rubber cable	No
Weight	422.7 g
Copper weight of the raw cable	0.029 kg/m

### Environmental requirements

Processing temperature	-5 ... +40 °C
Continuous operating temperature	-35 ... +85 °C
Note on continuous operating temperature	Cable for temperatures ≤ 70 °C (including halogen-free) Insulating parts for temperatures ≤ 105 °C

### Commercial data

PU (SPU)	1 pcs
Packaging type	unpacked
Country of origin	DE
GTIN	4055143841900
Customs tariff number	85444290900

### Product Classification

UNSPSC	26121629
ETIM 9.0	EC002587
ETIM 10.0	EC002587
ECCN	NO US CLASSIFICATION

### Environmental Product Compliance

RoHS Compliance Status	Compliant, No Exemption
------------------------	-------------------------

## Downloads

## Environmental Product Compliance

## Compliance Search

Environmental Product  
Compliance  
771-8382/066-501



## 1 Compatible Products

## 1.1 Required Accessories

## 1.1.1 Locking system

## 1.1.1.1 Locking system

[Item No.: 770-101](#)

Locking lever; for flying leads; for manual operation; black

[Item No.: 770-121](#)

Locking lever; for flying leads; for manual operation; white

[Item No.: 770-111](#)

Locking lever; for flying leads; for tool operation; black

[Item No.: 770-131](#)

Locking lever; for flying leads; for tool operation; white

## 1.2 Optional Accessories

## 1.2.1 Cover

## 1.2.1.1 Cover

[Item No.: 770-201](#)

Lockout cap; 12-pole, separable; for sockets; Plastic; black

[Item No.: 770-221](#)

Lockout cap; 12-pole, separable; for sockets; Plastic; white

[Item No.: 770-360](#)

Lockout cap; for plugs; 5-pole; separable; yellow

[Item No.: 897-2003](#)

Protective cap; Type2; for sockets and plugs; PVC; red

## 1.2.2 Installation

## 1.2.2.1 Mounting accessories

[Item No.: 770-310](#)

Mounting carrier; 2- to 5-pole; for flying leads; black

## 1.2.3 Marking

## 1.2.3.1 Marking strip

[Item No.: 210-334](#)

Marking strips; as a DIN A4 sheet; Strip width 5 mm; Strip length 182 mm; plain; Self-adhesive; white