

Data Sheet | Item Number: 771-8382/066-801

pre-assembled interconnecting cable; Cca; Socket/plug; 2-pole; Cod. I; H05Z1Z1-F
2 x 1,50 mm²; 8 m; 1,50 mm²

<https://www.wago.com/771-8382/066-801>

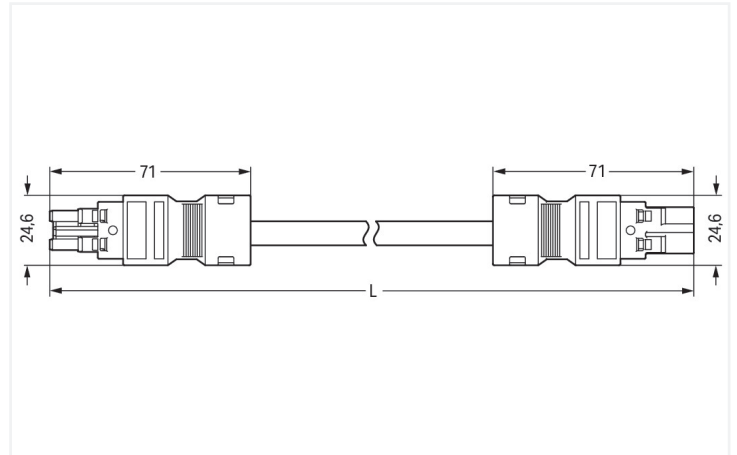

Dimensions in mm

Cable assembly WINSTA® MIDI I coding

The WINSTA® MIDI cable assembly 2-pole allows installation of solid and fine-stranded conductors. WAGO pluggable installation connectors can be used when requirements repeat or are planned on a specific grid, for example for installing grid lighting or flush-mount lighting. The color coding and mechanical coding of the pluggable installation connector ensure error-free installation of the individual components – including protection against mismatching. The pluggable installation connector offers touch-proof protection with live components in accordance with protection type IP20 (When mated: IP2xC (These compact connectors are not designed for use in open, easily accessible areas!)). WINSTA® MIDI pluggable installation connectors with I coding in blue are above all suitable for easy lighting installation, for instance for the dimming function of DALI lights. The WINSTA® MIDI product line achieves total flexibility for the electrical installation. With its Push-in CAGE CLAMP® spring pressure connection technology, it achieves time-saving, error-free installation and offers flexibility and customization for meeting various installation requirements. Scrupulous compliance with fire protection regulations is a crucial issue for building installation. Especially in sensitive areas, the fire class must meet or even exceed legal requirements. This product complies with the requirements of fire class C. The cable assembly is halogen-free. This eliminates the addition of environmental pollutants during production. It also achieves a higher fire class, since halogen-free materials are flame-resistant.

Fast, secure pluggable connections – cable assemblies from WAGO

The cable assembly is provided with a socket and a plug. The WINSTA® Pluggable Connection System is perfectly tailored to the very strict requirements of building installation. It makes electrical installation pluggable, and consequently more efficient, even more reliable, and error-free. Use of this pre-assembled system decreases assembly times and errors during installation at the construction site. Enjoy the benefits of the pluggable version of our maintenance-free spring pressure connection technology too! Plan your installation with with marking from WAGO.

- effective protection against mismatching
- for automation controllers
- for intelligent, easy lighting installation
- ready for immediate use
- convenient installation and commissioning

Notes

Note Cables with a different fire class can be found in the eShop.

Electrical data

Ratings per	IEC/EN 60664-1			General information	
Overtoltage category	III	III	II	Note on contact resistance	approx. 1 mΩ of contact resistance approx. 0.25 mΩ contact transition plug/ socket
Pollution degree	3	2	2		
Nominal voltage	250 V	-	-		
Rated impulse withstand voltage	4 kV	-	-		
Rated current	16 A	-	-		

Connection Data

Total number of potentials	2	Connection 1	
		Pole number	2
		Wire cross-section	1.5 mm ²
		Connection type	Socket - Plug

Physical data

Pin spacing	10 mm / 0.394 inches
Width	24.6 mm / 0.969 inches
Height	15.9 mm / 0.626 inches
Total length	8 m

Mechanical data

Use	DALI, Lighting Management
Coding	I
Variable coding	No
Marking	DA+ DA-
Potential marking	DA+ DA-
Mating force of a plug-in connection	approx. 20 ... 70 N (depending on pole number)
Retention force of a plug-in connection	when locked: > 80N
Unmating force of a plug-in connection	when unlocked: approx. 20 ... 70 N (depending on pole number)
Number of mating cycles	200, without resistive load
Connection type	Socket - Plug
Type of pre-assembled cable	Interconnecting cable
Cable type	H05Z1Z1-F 2x1.5
Protection type	IP20; When mated: IP2xC (These compact connectors are not designed for use in open, easily accessible areas!)

Plug-in connection

Mismating protection	Yes
Note on mismating protection	All <i>WINSTA</i> ® components are 100% protected against mismating when: a.) plugging different numbers of poles b.) plugging while rotated 180 c.) plugging while laterally staggered d.) plugging one pole
Locking lever	Can be retrofitted
Locking of plug-in connection	Locking lever
Note on locking system	All connectors for mounted installations (snap-in versions for lighting fixtures or devices, all types of PCB and distribution connectors) are factory-equipped with locking levers to ensure plugs and sockets are securely locked. Additional locking levers are only required for flying leads (plug/socket).

Material data

Note (material data)	Information on material specifications can be found here
Insulation material (main housing)	Polyamide (PA66)
Flammability class per UL94	V0
Fire class per EN 50575	C _{ca}
Contact material	Copper or copper alloy; surface-treated
Contact Plating	Tin
Fire load	7.456 MJ
Connector color	blue
Strain relief color	black
Sheathed cable color	black
Printing color of sheathed cable	white
Halogen-free	Yes
Silicon-free	Yes
Sheath material	Halogen-free
Rubber cable	No
Weight	662.7 g
Copper weight of the raw cable	0.029 kg/m

Environmental requirements

Processing temperature	-5 ... +40 °C
Continuous operating temperature	-35 ... +85 °C
Note on continuous operating temperature	Cable for temperatures ≤ 70 °C (including halogen-free) Insulating parts for temperatures ≤ 105 °C

Commercial data

PU (SPU)	1 pcs
Packaging type	unpacked
Country of origin	DE
GTIN	4055143841955
Customs tariff number	85444290900

Product Classification

UNSPSC	26121629
ETIM 9.0	EC002587
ETIM 10.0	EC002587
ECCN	NO US CLASSIFICATION

Environmental Product Compliance

RoHS Compliance Status	Compliant, No Exemption
------------------------	-------------------------

Downloads

Environmental Product Compliance

Compliance Search

Environmental Product
Compliance
771-8382/066-801



1 Compatible Products

1.1 Required Accessories

1.1.1 Locking system

1.1.1.1 Locking system

[Item No.: 770-101](#)

Locking lever; for flying leads; for manual operation; black

[Item No.: 770-121](#)

Locking lever; for flying leads; for manual operation; white

[Item No.: 770-111](#)

Locking lever; for flying leads; for tool operation; black

[Item No.: 770-131](#)

Locking lever; for flying leads; for tool operation; white

1.2 Optional Accessories

1.2.1 Cover

1.2.1.1 Cover

[Item No.: 770-201](#)

Lockout cap; 12-pole, separable; for sockets; Plastic; black

[Item No.: 770-221](#)

Lockout cap; 12-pole, separable; for sockets; Plastic; white

[Item No.: 770-360](#)

Lockout cap; for plugs; 5-pole; separable; yellow

[Item No.: 897-2003](#)

Protective cap; Type2; for sockets and plugs; PVC; red

1.2.2 Installation

1.2.2.1 Mounting accessories

[Item No.: 770-310](#)

Mounting carrier; 2- to 5-pole; for flying leads; black

1.2.3 Marking

1.2.3.1 Marking strip

[Item No.: 210-334](#)

Marking strips; as a DIN A4 sheet; Strip width 5 mm; Strip length 182 mm; plain; Self-adhesive; white